

# INTRODUCTION

# HOW TO USE THIS MANUAL

IN002-09

## INDEX

An INDEX is provided on the first page of each section to guide you to the item to be repaired. To assist you in finding your way through the manual, the Section Title and major heading are given at the top of every page.

## GENERAL DESCRIPTION

At the beginning of each section, a General Description is given that pertains to all repair operations contained in that section.

Read these precautions before starting any repair task.

## TROUBLESHOOTING

TROUBLESHOOTING tables are included for each system to help you diagnose the problem and find the cause.

## PREPARATION

Preparation lists the SST (Special Service Tools), recommended tools, equipment, lubricant and SSM (Special Service Materials) which should be prepared before beginning the operation and explains the purpose of each one.

## REPAIR PROCEDURES

Most repair operations begin with an overview illustration. It identifies the components and shows how the parts fit together.

Example:

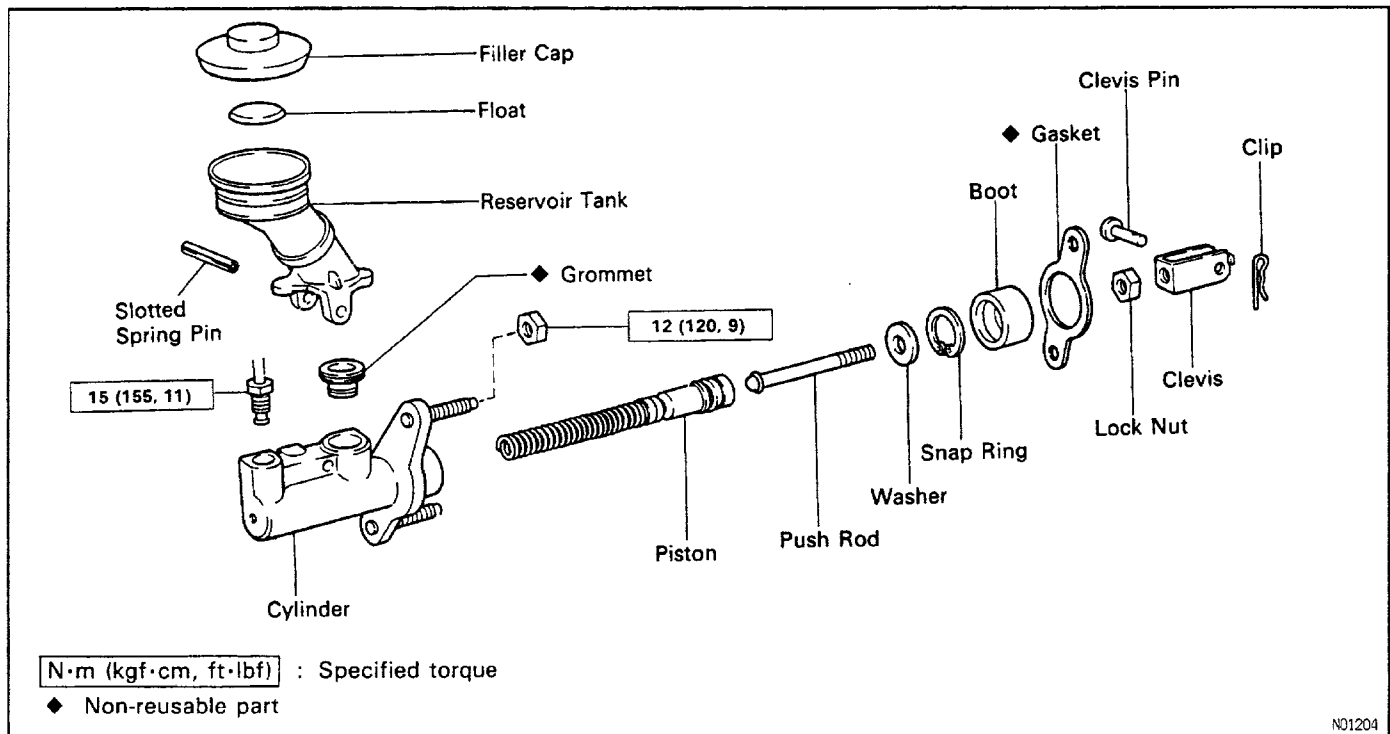

The procedures are presented in a step-by-step format:

Example:

- The illustration shows what to do and where to do it.
- The task heading tells what to do.
- The detailed text tells how to perform the task and gives other information such as specifications and warnings.

*Task heading : what to do*

**21. CHECK PISTON STROKE OF OVERDRIVE BRAKE**

- (a) Place SST and a dial indicator onto the overdrive brake piston as shown in the illustration.

**SST 09350-30020 (09350-06120)**

*Set part No.*

*Component part No.*

*Detailed text: how to do task*

- (b) Measure the stroke applying and releasing the compressed air (392 – 785 kPa, 4 – 8 kgf/cm<sup>2</sup> or 57 – 114 psi) as shown in the illustration.

**Piston stroke: 1.40 – 1.70 mm (0.0551 – 0.0669 in.)**

*Specification*

*Illustration:  
what to do and where*

This format provides the experienced technician with a FAST TRACK to the information needed. The upper case task heading can be read at a glance when necessary, and the text below it provides detailed information. Important specifications and warnings always stand out in bold type.

## REFERENCES

References have been kept to a minimum. However, when they are required you are given the page to refer to.

## SPECIFICATIONS

Specifications are presented in bold type throughout the text where needed. You never have to leave the procedure to look up your specifications. They are also found at the end of each section, for quick reference.

## CAUTIONS, NOTICES, HINTS:

- **CAUTIONS** are presented in bold type, and indicate there is a possibility of injury to you or other people.
- **NOTICES** are also presented in bold type, and indicate the possibility of damage to the components being repaired.
- **HINTS** are separated from the text but do not appear in bold. They provide additional information to help you perform the repair efficiently.

## SI UNIT

The UNITS given in this manual are primarily expressed according to the SI UNIT(International System of Unit), and alternately expressed in the metric system and in the English System.

Example:

**Torque: 30 N–m (310 kgf–cm, 22 ft–lbf)**

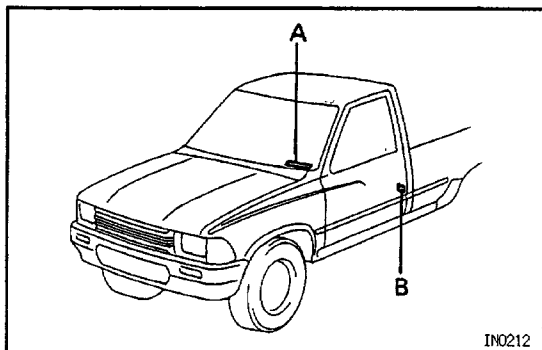

## IDENTIFICATION INFORMATION

### VEHICLE IDENTIFICATION NUMBER

INO03-01

The vehicle identification number is stamped on the vehicle identification number plate and certification label.

- A. Vehicle Identification Number Plate
- B. Certification Label

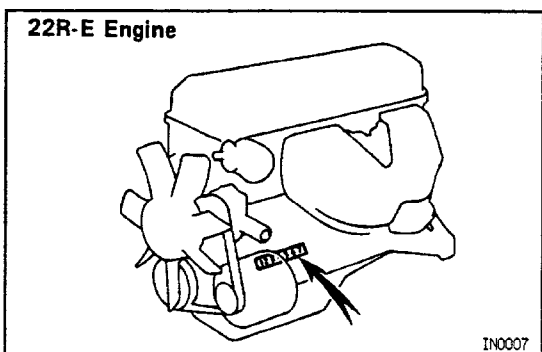

### ENGINE SERIAL NUMBER

INO0A-01

The engine serial number is stamped on the engine block as shown.

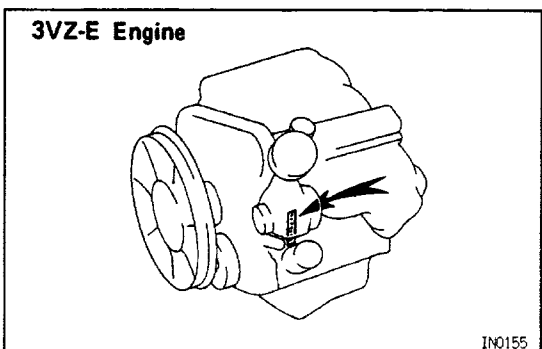

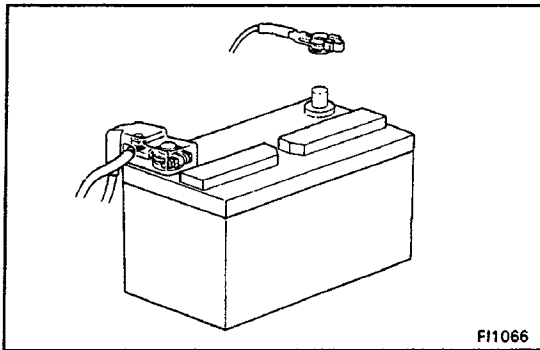

## GENERAL REPAIR INSTRUCTIONS

1. Use fender, seat and floor covers to keep the vehicle clean and prevent damage.
2. During disassembly, keep parts in the appropriate order to facilitate reassembly.
3. Observe the following:
  - (a) Before performing electrical work, disconnect the negative cable from the battery terminal.
  - (b) If it is necessary to disconnect the battery for inspection or repair, always disconnect the cable from the negative (-) terminal which is grounded to the vehicle body.
  - (c) To prevent damage to the battery terminal post, loosen the terminal nut and raise the cable straight up without twisting or prying it.
  - (d) Clean the battery terminal posts and cable terminals with a clean shop rag. Do not scrape them with a file or other abrasive objects.
  - (e) Install the cable terminal to the battery post with the nut loose, and tighten the nut after installation. Do not use a hammer to tap the terminal onto the post.
  - (f) Be sure the cover for the positive (+) terminal is properly in place.
4. Check hose and wiring connectors to make sure that they are secure and correct.
5. Non-reusable parts
  - (a) Always replace cotter pins, gaskets, O-rings and oil seals etc. with new ones.
  - (b) Non-reusable parts are indicated in the component illustrations by the "◆" symbol.

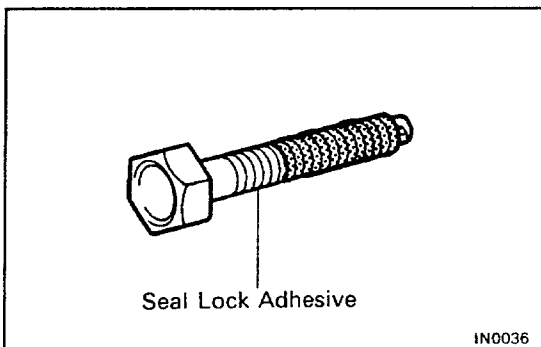

### 6. Precoated parts

Precoated parts are bolts and nuts, etc. that are coated with a seal lock adhesive at the factory.

- (a) If a precoated part is retightened, loosened or caused to move in any way, it must be recoated with the specified adhesive.

- (b) When reusing precoated parts, clean off the old adhesive and dry with compressed air. Then apply the specified seal lock adhesive to the bolt, nut or threads.
  - (c) Precoated parts are indicated in the component illustrations by the "\*" symbol.
7. When necessary, use a sealer on gaskets to prevent leaks.
  8. Carefully observe all specifications for bolt tightening torques. Always use a torque wrench.
  9. Use of special service tools (SST) and special service materials (SSM) may be required, depending on the nature of the repair. Be sure to use SST and SSM where specified and follow the proper work procedure. A list of SST and SSM can be found in the preparation part at the front of each section in this manual.

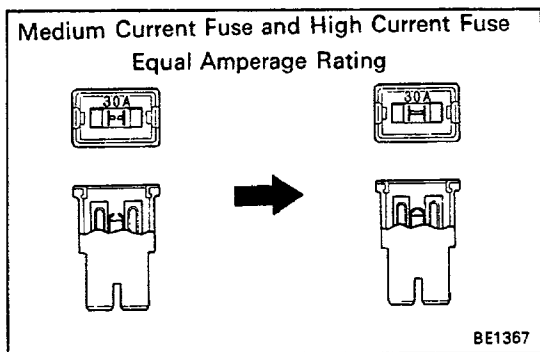

10. When replacing fuses, be sure the new fuse has the correct amperage rating. DO NOT exceed the rating or use one with a lower rating.

Illustration	Symbol	Part Name	Abbreviation
<p>BE5594</p>	<p>IN0365</p>	FUSE	FUSE
<p>BE5595</p>	<p>IN0366</p>	MEDIUM CURRENT FUSE	M-FUSE
<p>BE5596</p>	<p>IN0367</p>	HIGH CURRENT FUSE	H-FUSE
<p>BE5597</p>	<p>IN0367</p>	FUSIBLE LI1VK	FL
<p>BE5598</p>	<p>IN0368</p>	CIRCUIT BREAKER	CB

11. Care must be taken when jacking up and supporting the vehicle. Be sure to lift and support the vehicle at the proper locations (See page IN-9).
  - (a) If the vehicle is to be jacked up only at the front or rear end, be sure to block the wheels at the opposite end in order to ensure safety.
  - (6) After the vehicle is jacked up, be sure to support it on stands. It is extremely dangerous to do any work on a vehicle raised on a jack alone, even for a small job that can be finished quickly.
12. Observe the following precautions to avoid damage to the parts:
  - (a) Do not open the cover or case of the ECU, ECM, PCM or TCM unless absolutely necessary. (If the IC terminals are touched, the IC may be destroyed by static electricity.)

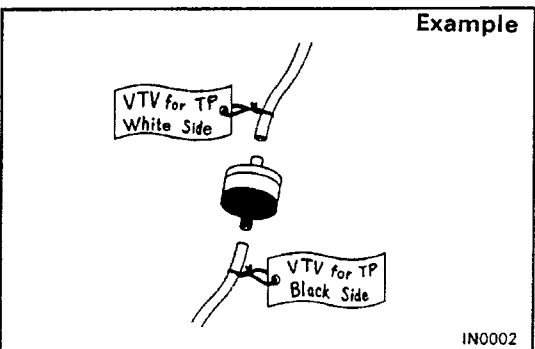
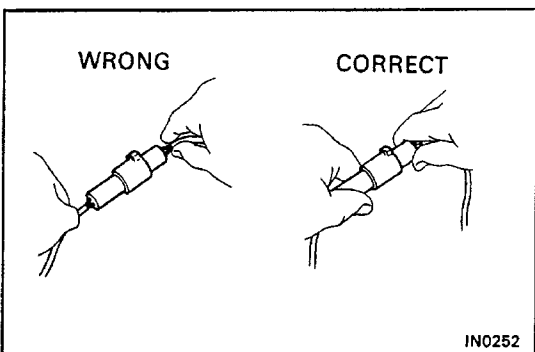
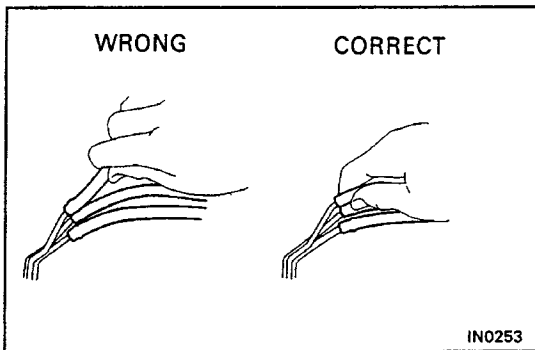

- (b) To disconnect vacuum hoses, pull on the end, not the middle of the hose.
  - (c) To pull apart electrical connectors, pull on the connector itself, not the wires.
  - (d) Be careful not to drop electrical components, such as sensors or relays. If they are dropped on a hard floor, they should be replaced and not reused.
  - (e) When steam cleaning an engine, protect the distributor, air filter, and VCV from water.
  - (f) Never use an impact wrench to remove or install temperature switches or temperature sensors.
  - (g) When checking continuity at the wire connector, insert the tester probe carefully to prevent terminals from bending.
  - (h) When using a vacuum gauge, never force the hose onto a connector that is too large. Use a step-down adapter instead. Once the hose has been stretched, it may leak.
13. Tag hoses before disconnecting them:
    - (a) When disconnecting vacuum hoses, use tags to identify how they should be reconnected.
    - (b) After completing a job, double check that the vacuum hoses are properly connected. A label under the hood shows the proper layout.

## PRECAUTION FOR VEHICLES EQUIPPED WITH A CATALYTIC CONVERTER

IN006-01

**CAUTION:** If large amounts of unburned gasoline flow into the converter, it may overheat and create a fire hazard. To prevent this, observe the following precautions and explain them to your customer.

**1. Use only unleaded gasoline.**

**2. Avoid prolonged idling.**

Avoid running the engine at idle speed for more than 20 minutes.

**3. Avoid spark jump test.**

(a) Perform spark jump test only when absolutely necessary. Perform this test as rapidly as possible.

(b) While testing, never race the engine.

**4. Avoid prolonged engine compression measurement.**

Engine compression tests must be done as rapidly as possible.

**5. Do not run engine when fuel tank is nearly empty.**

This may cause the engine to misfire and create an extra load on the converter.

**6. Avoid coasting with ignition turned off and prolonged braking.**

**7. Do not dispose of used catalyst along with parts contaminated with gasoline or oil.**

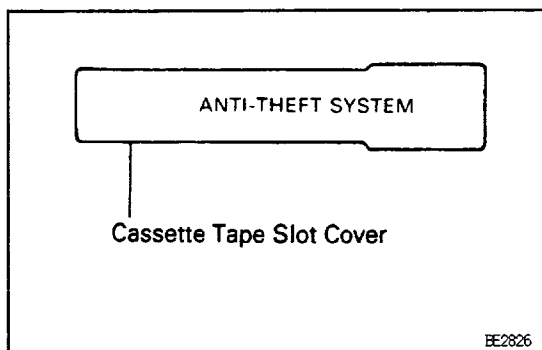

IN-01

## FOR VEHICLES WITH AN AUDIO SYSTEM WITH BUILT-IN ANTI-THEFT SYSTEM

Audio System displaying the sign "ANTI-THEFT SYSTEM" shown on the left has a built-in anti-theft system which makes the audio system soundless if stolen.

If the power source for the audio system is cut even once, the anti-theft system operates so that even if the power source is reconnected, the audio system will not produce any sound unless the ID number selected by the customer is input again. Accordingly, when performing repairs on vehicles equipped with this system, before disconnecting the battery terminals or removing the audio system the customer should be asked for the ID number so that the technician can input the ID number afterwards, or else a request made to the customer to input the ID number. For the method to input the ID number or cancel the anti-theft system, refer to the Owner's Manual.



# VEHICLE LIFT AND SUPPORT LOCATIONS

IN007-01

[2WD]

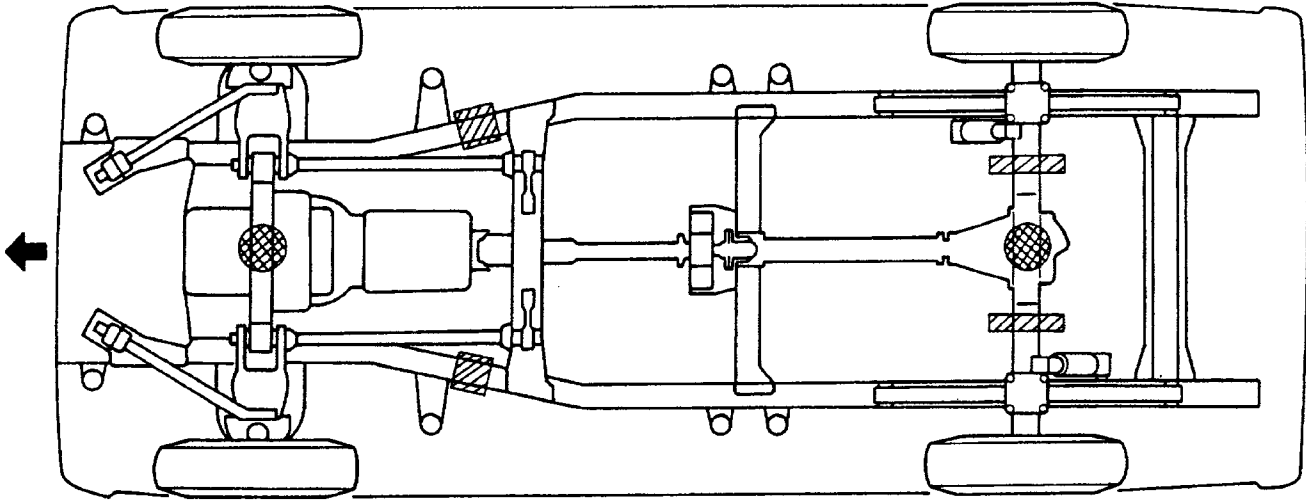

[4WD]

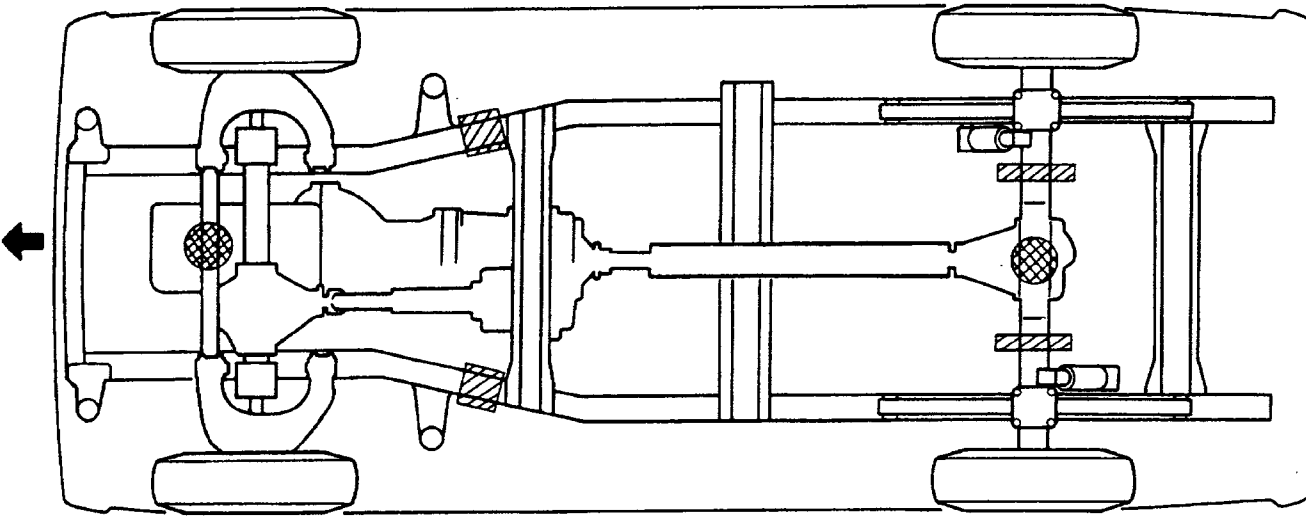

**JACK POSITION** ..... 

Front ..... Center of crossmember

Rear ..... Under the rear differential

**SUPPORT POSITION**

Safety stand ..... 

IN0012  
IN0108

Z04590

# ABBREVIATIONS USED IN THIS MANUAL

IN01D-0C

ADD	Automatic Disconnecting Differential
ALR	Automatic Locking Retractor
A/T	Automatic Transmission
ATF	Automatic Transmission Fluid
BTDC	Before Top Dead Center
Calif.	California
CB	Circuit Breaker
C&C	Cab and Chassis
DP	Dash Pot
DRW	Double Rear Wheel
ECU	Electronic Control Unit
ELR	Emergency Locking Retractor
ESA	Electronic Spark Advance
EX	Exhaust (Manifold, Valve)
Ex.	Except
Fed.	Vehicles Sold in USA except California
FIPG	Formed in Place Gasket
FL	Fusible Link
Fr	Front
IG	Ignition
IN	Intake (Manifold, Valve)
J/6	Junction Block
LH	Left-Hand
LSPV	Load Sensing Proportioning Valve
LSP & BV	Load Sensing Proportioning and By-Pass Valve
Max.	Maximum
Min.	Minimum
MP	Multipurpose
M/T	Manual Transmission
O/D, OD	Overdrive
OHC	Over Head Camshaft
o/s	Oversize
PCV	Positive Crankcase Ventilation
PPS	Progressive Power Steering
PS	Power Steering
RH	Right-Hand
Rr	Rear
SRW	Single Rear Wheel
SSM	Special Service Materials
SST	Special Service Tools
STD	Standard
SW	Switch

---

TCCS	Toyota Computer Controlled System
TDC	Top Dead Center
TEMP.	Temperature
T/M	Transmission
U/S	Undersize
VCV	Vacuum Control Valve
VSV	Vacuum Switching Valve
VTV	Vacuum Transmitting Valve
w/	With
w/o	Without
2WD	Two Wheel Drive Vehicles (4 x 2)
4WD	Four Wheel Drive Vehicles (4 x 4)

# GLOSSARY OF SAE AND TOYOTA TERMS

M078-03

This glossary lists all SAE-J 1930 terms and abbreviations used in this manual in compliance with SAE recommendations, as well as their Toyota equivalents.

SAE ABBRE- VIATIONS	SAE TERMS	TOYOTA TERMS ( )—ABBREVIATIONS
A/C	Air Conditioning	Air Conditioner
ACL	Air Cleaner	Air Cleaner
AIR	Secondary Air Injection	Air Injection (AD)
AP	Accelerator Pedal	--
B +	Battery Positive Voltage	+ B, Battery Voltage
BARO	Barometric Pressure	--
CAC	Charge Air Cooler	Intercooler
CARB	Carburetor	Carburetor
CFI	Continuous Fuel Injection	--
CKP	Crankshaft Position	Crank Angle
CL	Closed Loop	Closed Loop
CMP	Camshaft Position	Cam Angle
CPP	Clutch Pedal Position	--
CTOX	Continuous Trap Oxidizer	--
CT P	Closed Throttle Position	--
D FI	Direct Fuel Injection (Diesel)	Direct Injection (DI)
DI	Distributor ignition	--
DLC1 DLC2 DLC3	Data Link Connector 1 Data Link Connector 2 Data Link Connector 3	1: Check Connector 2: Toyota Diagnosis Communication Link (TDCL) 3: OBDII Diagnostic Connector
DTC	Diagnostic Trouble Code	Diagnostic Code
DTM	Diagnostic Test Mode	--
ECL	Engine Control Level	--
ECM	Engine Control Module	Engine ECU (Electronic Control Unit)
ECT	Engine Coolant Temperature	Coolant Temperature, Water Temperature (THW)
EEPROM	Electrically Erasable Programmable Read Only Memory	Electrically Erasable Programmable Read Only Memory (EEPROM), Erasable Programmable Read Only Memory (EPROM)
EFE	Early Fuel Evaporation	Cold Mixture Heater (CMH), Heat Control Valve (HCV)
EGR	Exhaust Gas Recirculation	Exhaust Gas Recirculation (EGR)
EI	Electronic Ignition	Toyota Distributable Ignition (TDI)
EM	Engine Modification	Engine Modification (EM)
EPROM	Erasable Programmable Read Only Memory	Programmable Read Only Memory (PROM)
EVAP	Evaporative Emission	Evaporative Emission Control (EVAP)
FC	Fan Control	--
FEEPROM	Flash Electrically Erasable Programmable Read Only Memory	--
FEPROM	Flash Erasable Programmable Read Only Memory	--
FF	Flexible Fuel	--
FP	Fuel Pump	Fuel Pump
GEN	Generator	Alternator
GND	Ground	Ground (GND)
H02S	Heated Oxygen Sensor	Heated Oxygen Sensor (H02S)









IAC	Idle Air Control	Idle Speed Control (ISC)
IAT	Intake Air Temperature	Intake or Inlet Air Temperature
ICM	Ignition Control Module	–
IFI	Indirect Fuel Injection	Indirect injection
IFS	Inertia Fuel-Shutoff	–
ISC	Idle Speed Control	–
KS	Knock Sensor	Knock Sensor
MAF	Mass Air Flow	Air Flow Meter
MAP	Manifold Absolute Pressure	Manifold Pressure Intake Vacuum
MC	Mixture Control	Electric Bleed Air Control Valve (EBCV) Mixture Control Valve (MCV) Electric Air Control Valve (EACV)
MDP	Manifold Differential Pressure	–
MFI	Multiport Fuel Injection	Electronic Fuel Injection (EFI)
MIL	Malfunction Indicator Lamp	Check Engine Light
MST	Manifold Surface Temperature	–
MVZ	Manifold Vacuum Zone	–
NVRAM	Non-Volatile Random Access Memory	–
O2S	Oxygen Sensor	Oxygen Sensor, O <sub>2</sub> Sensor (O2S)
OBD	On-Board Diagnostic	On-Board Diagnostic (OBD)
OC	Oxidation Catalytic Converter	Oxidation Catalyst Converter (OC), CCo
OP	Open Loop	Open Loop
PAIR	Pulsed Secondary Air Injection	Air Suction (AS)
PCM	Powertrain Control Module	–
PNP	Park/Neutral Position	–
PROM	Programmable Read Only Memory	–
PSP	Power Steering Pressure	–
PTOX	Periodic Trap Oxidizer	Diesel Particulate Filter (DPF) Diesel Particulate Trap (DPT)
RAM	Random Access Memory	Random Access Memory (RAM)
RM	Relay Module	–
ROM	Read Only Memory	Read Only Memory (ROM)
RPM	Engine Speed	Engine Speed
SC	Supercharger	Supercharger
SCB	Supercharger Bypass	–
SFI	Sequential Multiport Fuel Injection	Electronic Fuel Injection (EFI), Sequential Injection
SPL	Smoke Puff Limiter	–
SRI	Service Reminder Indicator	–
SRT	System Readiness Test	–
ST	Scan Tool	–
TB	Throttle Body	Throttle Body
TBI	Throttle Body Fuel Injection	Single Point Injection Central Fuel Injection (Ci)
TC	Turbocharger	Turbocharger
TCC	Torque Converter Clutch	Torque Converter
TCM	Transmission Control Module	Transmission ECU (Electronic Control Unit)
TP	Throttle Position	Throttle Position
TR	Transmission Range	–

TVV	Thermal Vacuum Valve	Bimetal Vacuum Switching Valve (BVSV) Thermostatic Vacuum Switching Valve (TVSV)
twc	Three-Way Catalytic Converter	Three-Way Catalyst (TWC) CCRO
TWC+OC	Three-Way + Oxidation Catalytic Converter	CC <sub>R</sub> + CCo
VAF	Volume Air Flow	Air Flow Meter
VR	Voltage Regulator	Voltage Regulator
VSS	Vehicle Speed Sensor	Vehicle Speed Sensor (Read Switch Type)
wot	Wide Open Throttle	Full Throttle
WU-OC	Warm Up Oxidation Catalytic Converter	-
WU-TWC	Warm Up Three-Way Catalytic Converter	Manifold Converter
3GR	Third Gear	--
4GR	Fourth Gear	--

# STANDARD BOLT TORQUE SPECIFICATIONS

IN008-01

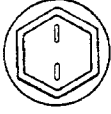
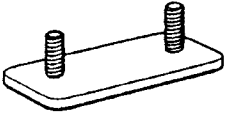
## HOW TO DETERMINE BOLT STRENGTH

	Mark	Class		Mark	Class
Hexagon head bolt	 <p>Bolt head No</p> <p>4- 5- 6- 8- 9- 10- 11-</p>	<p>4T 5T 6T 7T 8T 9T 10T 11T</p>	Stud bolt	 <p>No mark</p>	4T
	 <p>No mark</p>	4T			
Hexagon flange bolt w/ washer hexagon bolt	 <p>No mark</p>	4T	Welded bolt	 <p>Grooved</p>	6T
Hexagon head bolt	 <p>Two protruding lines</p>	5T			
Hexagon flange bolt w/ washer hexagon bolt	 <p>Two protruding lines</p>	6T	Welded bolt		4T
Hexagon head bolt	 <p>Three protruding lines</p>	7T			
Hexagon head bolt	 <p>Four protruding lines</p>	8T			

## SPECIFIED TORQUE FOR STANDARD BOLTS

Class	Diameter mm	Pitch mm	Specified torque					
			Hexagon head bolt			Hexagon flange bolt		
			N·m	kgf·cm	ft·lbf	N·m	kgf·cm	ft·lbf
4T	6	1	5	55	48 in.·lbf	6	60	52 in.·lbf
	8	1.25	12.5	130	9	14	145	10
	10	1.25	26	260	19	29	290	21
	12	1.25	47	480	35	53	540	39
	14	1.5	74	760	55	84	850	61
	16	1.5	115	1,150	83	—	—	—
5T	6	1	6.5	65	56 in.·lbf	7.5	75	65 in.·lbf
	8	1.25	15.5	160	12	17.5	175	13
	10	1.25	32	330	24	36	360	26
	12	1.25	59	600	43	65	670	48
	14	1.5	91	930	67	100	1,050	76
	16	1.5	140	1,400	101	—	—	—
6T	6	1	8	80	69 in.·lbf	9	90	78 in.·lbf
	8	1.25	19	195	14	21	210	15
	10	1.25	39	400	29	44	440	32
	12	1.25	71	730	53	80	810	59
	14	1.5	110	1,100	80	125	1,250	90
	16	1.5	170	1,750	127	—	—	—
7T	6	1	10.5	110	8	12	120	9
	8	1.25	25	260	19	28	290	21
	10	1.25	52	530	38	58	590	43
	12	1.25	95	970	70	105	1,050	76
	14	1.5	145	1,500	108	165	1,700	123
	16	1.5	230	2,300	166	—	—	—
8T	8	1.25	29	300	22	33	330	24
	10	1.25	61	620	45	68	690	50
	12	1.25	110	1,100	80	120	1,250	90
9T	8	1.25	34	340	25	37	380	27
	10	1.25	70	710	51	78	790	57
	12	1.25	125	1,300	94	140	1,450	105
10T	8	1.25	38	390	28	42	430	31
	10	1.25	78	800	58	88	890	64
	12	1.25	140	1,450	105	155	1,600	116
11T	8	1.25	42	430	31	47	480	35
	10	1.25	87	890	64	97	990	72
	12	1.25	155	1,600	116	175	1,800	130



# CLUTCH

.

## TROUBLESHOOTING

Problem	Possible cause	Remedy	Page
Hard to shift or will not shift	Clutch pedal freeplay excessive Air in clutch lines Clutch release cylinder faulty Clutch master cylinder faulty Clutch disc out of true, runout is excessive or lining broken Splines on input shaft or clutch disc dirty or burred Clutch pressure plate faulty	Adjust pedal freeplay Bleed clutch system Repair release cylinder Repair master cylinder Inspect clutch disc  Repair as necessary  Replace clutch cover	CL-3 CL-4 CL-10 CL-7 CL-13  CL-12  CL-14
Transmission jumps out of gear	Clutch pilot bearing worn	Replace pilot bearing	CL-14
Clutch slips	Clutch pedal freeplay insufficient Clutch disc lining oily or worn out Pressure plate faulty Release fork binding	Adjust pedal freeplay Inspect clutch disc Replace clutch cover Inspect release fork	CL-3 CL-13 CL-14
Clutch grabs/ chatters	Clutch disc lining oily or worn out Pressure plate faulty Clutch diaphragm spring bent Engine mounts loose	Inspect clutch disc Replace clutch cover Align clutch diaphragm Repair as necessary	CL-13 CL-14 CL-15
Clutch pedal spongy	Air in clutch lines Clutch release cylinder faulty Clutch master cylinder faulty	Bleed clutch system Repair release cylinder Repair master cylinder	CL-4 CL-10 CL-7
Clutch noisy	Loose part inside housing Release bearing worn or dirty Pilot bearing worn Release fork or linkage sticking	Repair as necessary Replace release bearing Replace pilot bearing Repair as necessary	CL-15 CL-14

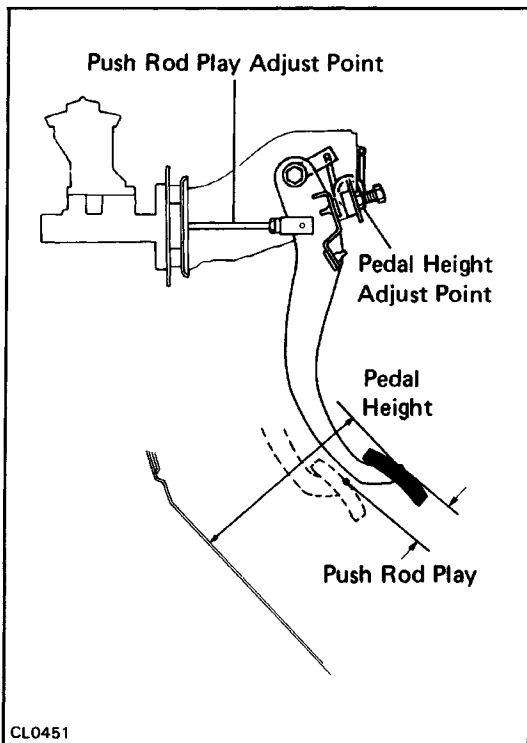

CL0451

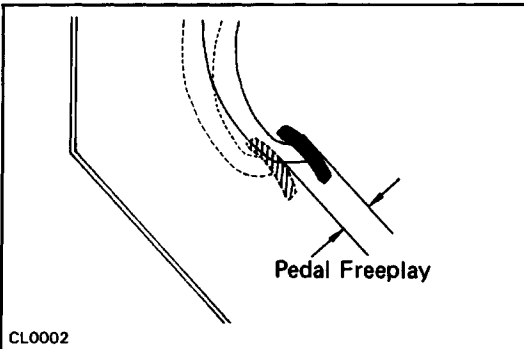

CL0002

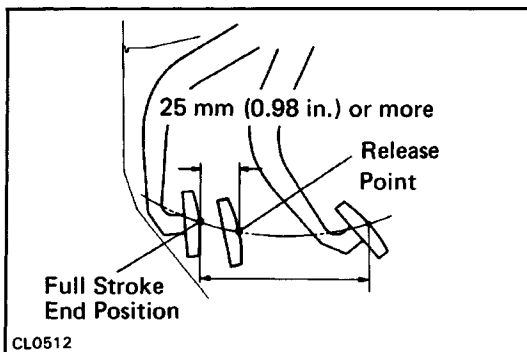

CL0512

## CHECK AND ADJUSTMENT OF CLUTCH PEDAL

### 1. CHECK THAT PEDAL HEIGHT AND PUSH ROD PLAY ARE CORRECT

#### Pedal height

(from asphalt sheet): 2WD 154.5 mm (6.0827 in.)

4WD 151.5 mm (5.9646 in.)

(from floor panel): 157.5 mm (6.201 in.)

Push rod play at pedal top: 1.0 – 5.0 mm

(0.039 – 0.197 in.)

If incorrect, adjust the pedal height and push rod play.

### 2. IF NECESSARY, ADJUST PEDAL HEIGHT AND PUSH ROD PLAY

- Loosen the lock nut and turn the stopper bolt until the height is correct. Tighten the lock nut.
- Loosen the lock nut and turn the push rod until the push rod play is correct. Tighten the lock nut.

### 3. CHECK THAT PEDAL FREEPLAY IS CORRECT

Push in on the pedal until the beginning of clutch resistance is felt.

**Pedal freeplay: 5 – 15 mm (0.20 – 0.59 in.)**

### 4. IF NECESSARY, ADJUST PEDAL FREEPLAY

- Loosen the lock nut and turn the push rod until the freeplay is correct.
- Tighten the lock nut.
- After adjusting the pedal freeplay, check the pedal height.

### 5. INSPECT CLUTCH RELEASE POINT

- Pull the parking brake lever and install wheel stopper.
- Start the engine and idle the engine.
- Without depressing the clutch pedal, slowly shift the shift lever into reverse position until the gears contact.
- Gradually depress the clutch pedal and measure the stroke distance from the point the gear noise stops (release point) up to the full stroke end position.

**Standard distance: 25 mm (0.98 in.) or more**

**(From pedal stroke end position to release point)**

If the distance not as specified, perform the following operation.

- Inspect pedal height.
- Inspect push rod play and pedal free play.
- Bleed the clutch line.
- Inspect the clutch cover and disc.

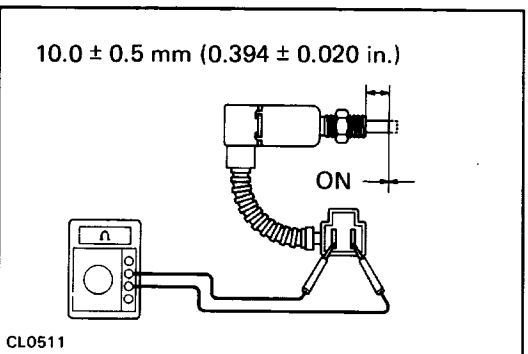
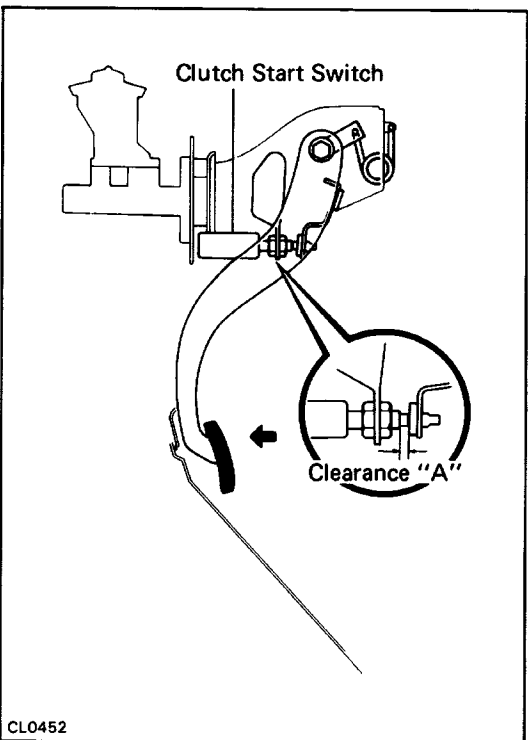
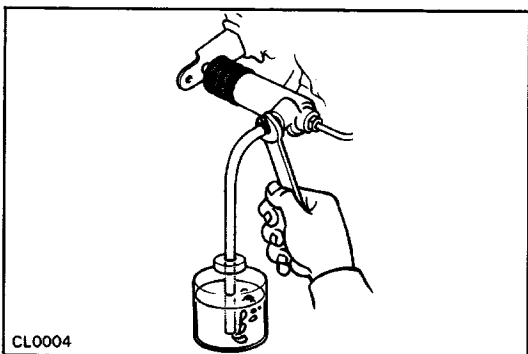
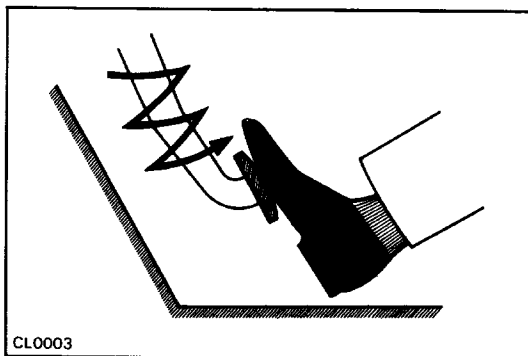

## BLEEDING OF CLUTCH SYSTEM

**HINT:** If any work is done on the clutch system or if air is suspected in the clutch lines, bleed the system of air.

**NOTICE:** Do not let brake fluid remain on a painted surface. Wash it off immediately.

### 1. FILL CLUTCH RESERVOIR WITH BRAKE FLUID

Check the reservoir frequently. Add fluid if necessary.

### 2. CONNECT VINYL TUBE TO BLEEDER PLUG

Insert the other end of the tube in a half-full container of brake fluid.

### 3. BLEED CLUTCH LINE

- Slowly pump the clutch pedal several times.
- While pressing on the pedal, loosen the bleeder plug until the fluid starts to run out. Then close the bleeder plug.
- Repeat this procedure until there are no more air bubbles in the fluid.

## INSPECTION OF CLUTCH START SYSTEM

### CHECK CLUTCH PEDAL

#### 1. CHECK THAT PEDAL HEIGHT IS CORRECT

(See page [CL-3](#))

#### 2. CHECK THAT PEDAL FREEPLAY AND PUSH ROD PLAY ARE CORRECT

(See page [CL-3](#))

## CHECK CLUTCH START SYSTEM

### CHECK CLUTCH START SYSTEM

- Check that the engine does not start when the clutch pedal is released.
- Check that the engine starts when the clutch pedal is fully depressed.
- Check that clearance "A" is greater than 1 mm (0.04 in.) when the clutch is fully depressed. If necessary, adjust or replace the clutch start switch.

## INSPECTION AND ADJUSTMENT OF CLUTCH START SWITCH

### 1. INSPECT CONTINUITY OF CLUTCH START SWITCH

- Check that there is continuity between terminals when the switch is ON (pushed).
- Check that there is no continuity between terminals when the switch is OFF (free). If continuity is not as specified, replace the switch.

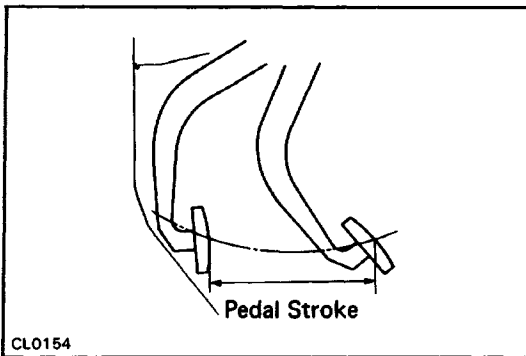

## 2. ADJUST CLUTCH START SWITCH

- (a) Measure the pedal stroke, and check the switch clearance "A" using the chart left.
- (b) Loosen and adjust the switch position.

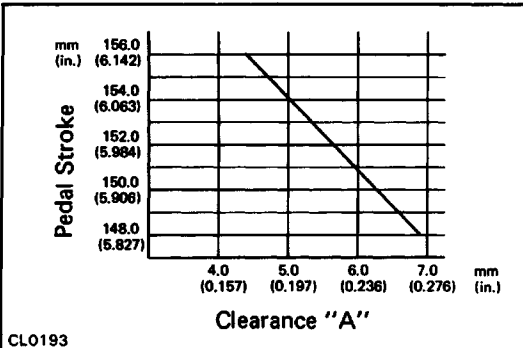

- (c) Recheck that the engine does not start when the clutch pedal is released.

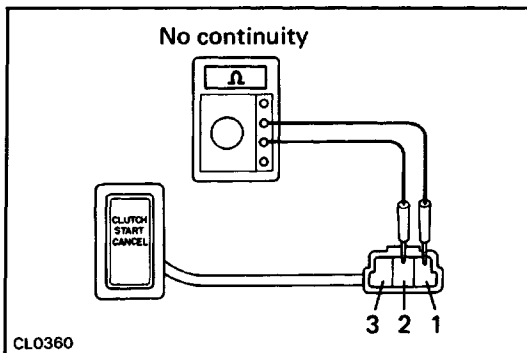

## INSPECTION OF CLUTCH START CANCEL SWITCH

### 1. INSPECT CONTINUITY OF CLUTCH START CANCEL SWITCH

- (a) Check that there is no continuity when connect the positive (+) lead from the ohmmeter to terminal 2 and the negative (-) lead to terminal 1.

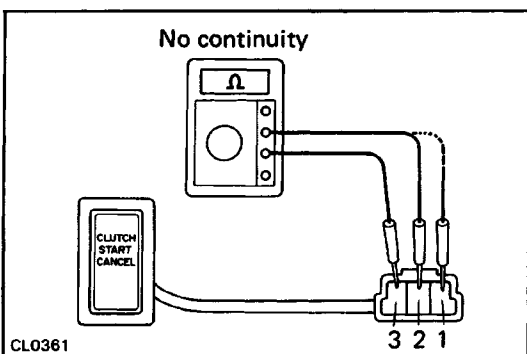

- (b) Check that there is no continuity when connect the positive (+) lead from the ohmmeter to terminal 3 and the negative (-) lead to terminal 1.

- (c) Check that there is no continuity between terminals 2 and 3.

If continuity is not as specified, replace the clutch start cancel switch.

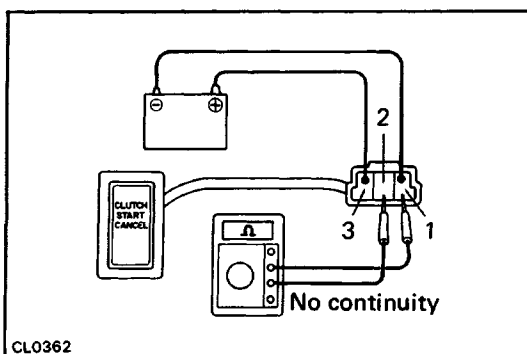

### 2. INSPECT OPERATION OF CLUTCH START CANCEL SWITCH

- (a) Connect positive (+) lead from the battery to terminal 3 and connect negative (-) lead to terminal 1.
- (b) Check that there is no continuity when connect the positive (+) lead from the ohmmeter to terminal 2 and the negative (-) lead to terminal 1.

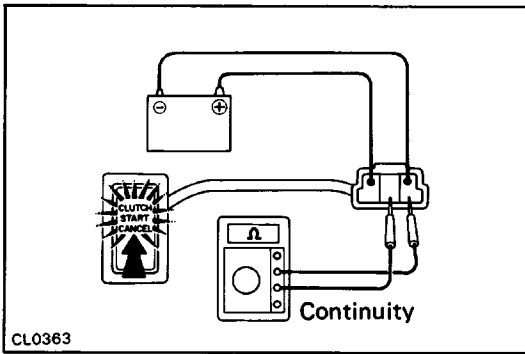

- (c) When pushing the switch, check that the indicator light comes on and there is continuity between terminals 1 and 2.

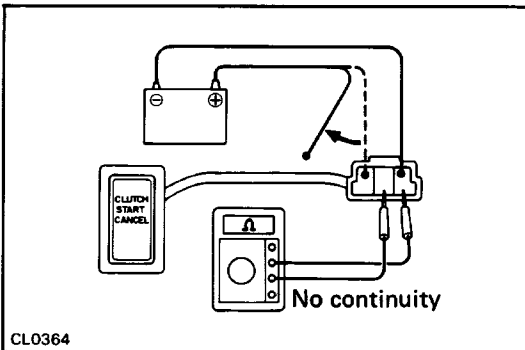

- (d) Check that there is no continuity between terminals 1 and 2 when disconnect the battery lead. If operation is not as specified, replace the clutch start cancel switch.

# CLUTCH MASTER CYLINDER COMPONENTS

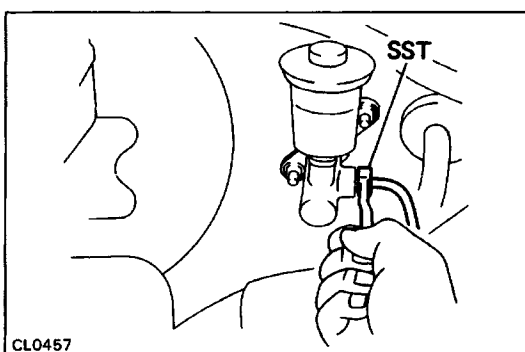
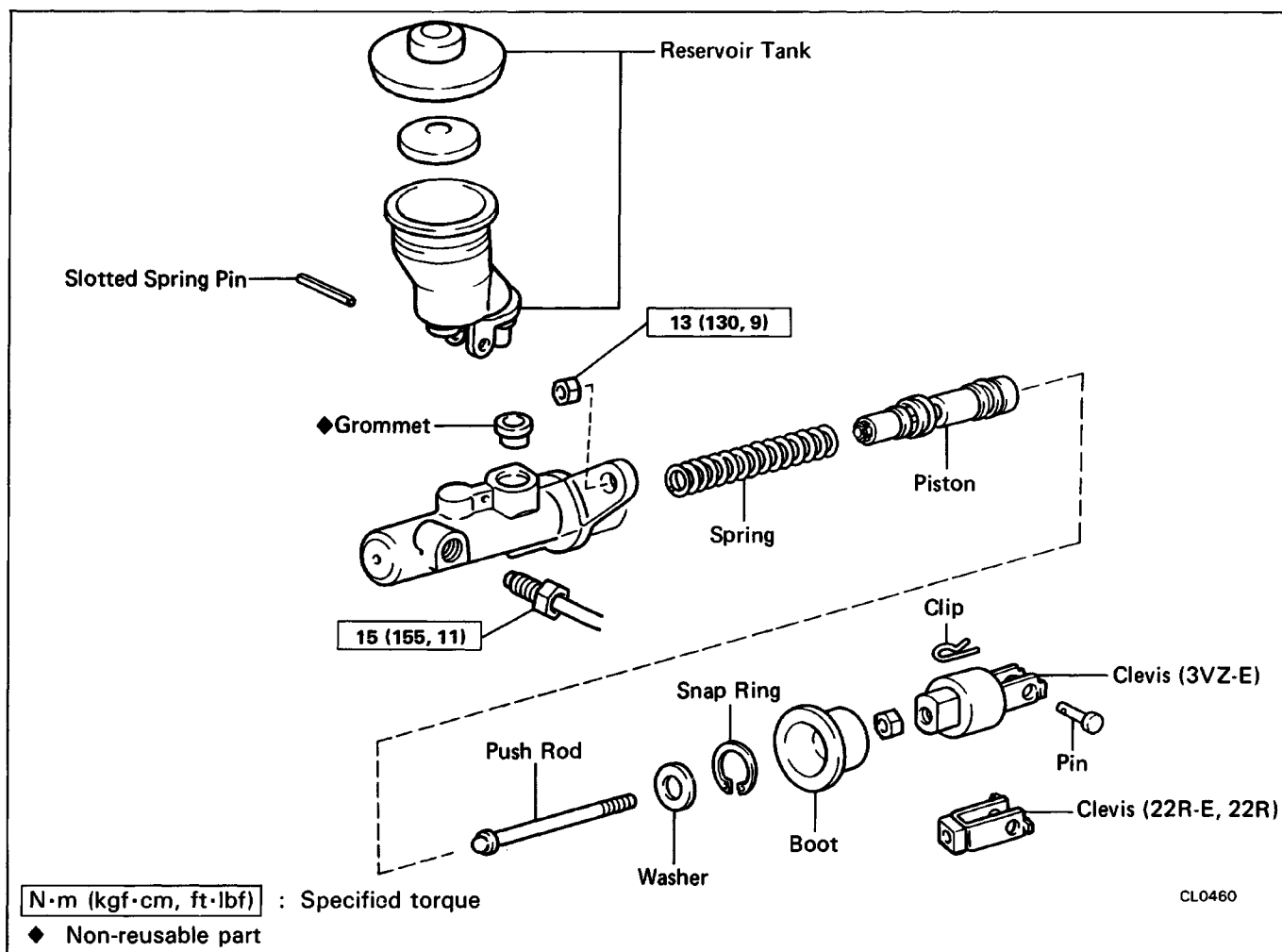

## REMOVAL OF MASTER CYLINDER

1. REMOVE PUSH ROD PIN
2. DISCONNECT CLUTCH LINE UNION

Using SST, disconnect the union nut.

SST 09751-36011

3. REMOVE MASTER CYLINDER

- (a) Remove the mounting nut.
- (b) Pull out the master cylinder.

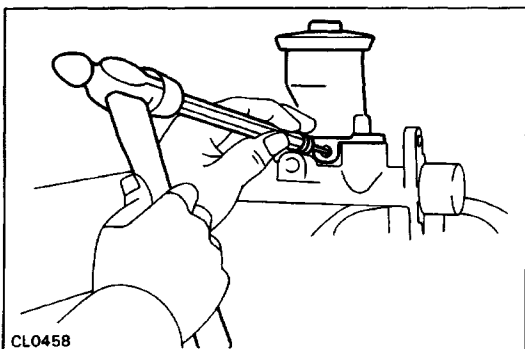

## DISASSEMBLY OF MASTER CYLINDER

1. REMOVE RESERVOIR TANK

- (a) Using a pin punch and a hammer, drive out the slotted spring pin.
- (b) Remove reservoir tank and grommet.

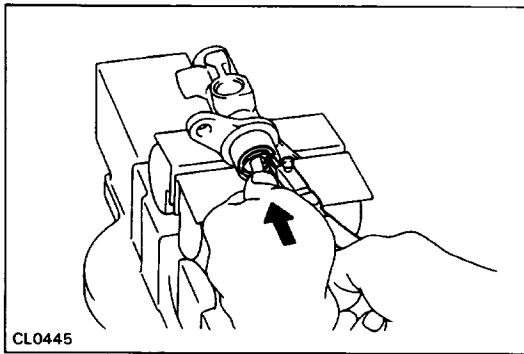

## 2. REMOVE PUSH ROD

- (a) Pull back the boot and, using snap ring pliers, remove the snap ring.
- (b) Pull out the push rod and washer.
- (c) Remove the piston from the cylinder.

## INSPECTION OF MASTER CYLINDER

HINT: Clean the disassembled parts with compressed air.

### 1. INSPECT MASTER CYLINDER BORE FOR SCORING OR CORROSION.

If a problem is found, clean or replace the cylinder.

### 2. INSPECT PISTON AND CUPS FOR WEAR, SCORING, CRACKS OR SWELLING

If either one requires replacement, use the parts from the cylinder kit.

### 3. INSPECT PUSH ROD FOR WEAR OR DAMAGE

If necessary, replace the push rod.

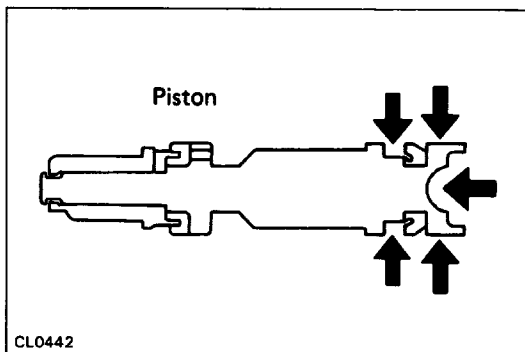

## ASSEMBLY OF MASTER CYLINDER

### 1. COAT PARTS WITH LITHIUM SOAP BASE GLYCOL GREASE, AS SHOWN

### 2. INSERT PISTON INTO CYLINDER

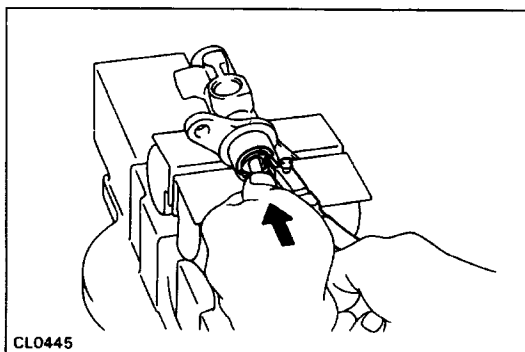

### 3. INSTALL PUSH ROD ASSEMBLY WITH SNAP RING



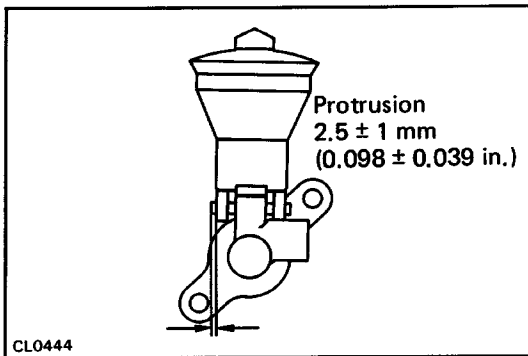

#### 4. INSTALL RESERVOIR TANK

- (a) Install reservoir tank and new grommet.
- (b) Using a pin punch and a hammer, drive in the slotted spring pin.

#### INSTALLATION OF MASTER CYLINDER

(See page [CL-7](#))

##### 1. INSTALL MASTER CYLINDER

Install the mounting nut, and torque them.

**Torque: 13 N-m (130 kgf-cm, 9 ft-lbf)**

##### 2. CONNECT CLUTCH LINE UNION

Using SST, connect the union.

SST 09751-36011

##### 3. CONNECT PUSH ROD AND INSTALL PIN

Install the clip in the push rod pin.

##### 4. BLEED SYSTEM AND ADJUST CLUTCH PEDAL

(See page [CL-4](#))

## CLUTCH RELEASE CYLINDER COMPONENTS

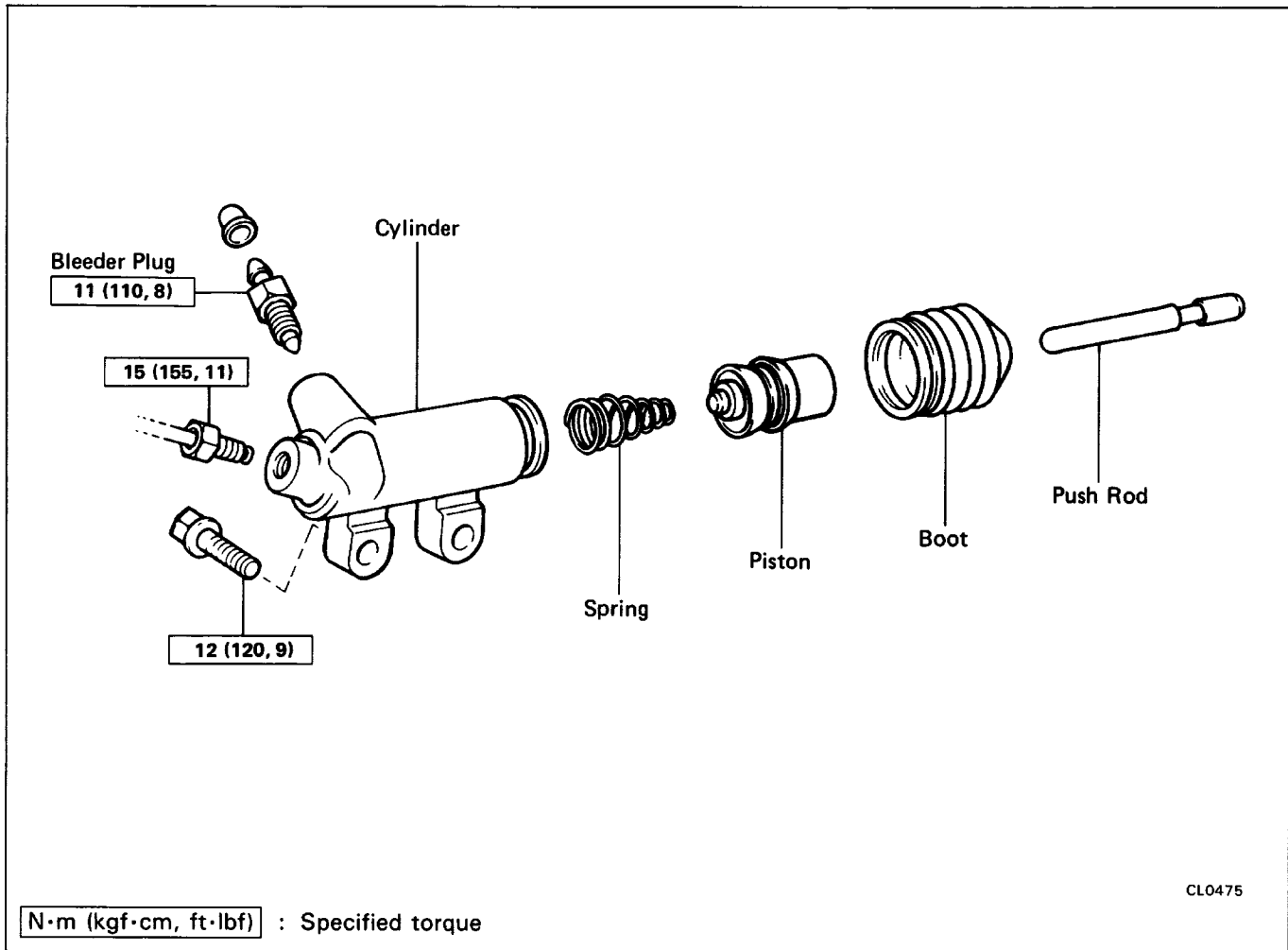

### REMOVAL OF RELEASE CYLINDER

#### 1. DISCONNECT CLUTCH LINE UNION

Using SST, disconnect the union.

SST 09751-36011

#### 2. REMOVE TWO BOLTS AND PULL OFF RELEASE CYLINDER

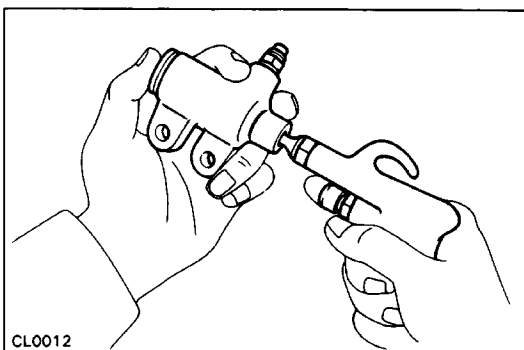

CL0012

### DISASSEMBLY OF RELEASE CYLINDER

#### 1. PULL OUT PUSH ROD

#### 2. REMOVE BOOT

#### 3. REMOVE PISTON

## INSPECTION OF RELEASE CYLINDER

HINT: Clean the disassembled parts with compressed air.

### 1. INSPECT RELEASE CYLINDER BORE FOR SCORING OR CORROSION

If a problem is found, clean or replace the cylinder.

### 2. INSPECT PISTON AND CUPS FOR WEAR, SCORING, CRACKS OR SWELLING

If either one requires replacement, use the parts from the cylinder kit.

### 3. INSPECT PUSH ROD FOR WEAR OR DAMAGE

If necessary, replace the push rod.

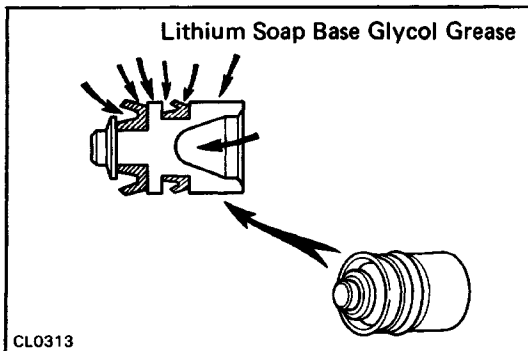

## ASSEMBLY OF RELEASE CYLINDER

(See page [CL-10](#))

1. COAT PISTON WITH LITHIUM SOAP BASE GLYCOL GREASE, AS SHOWN
2. INSTALL PISTON
3. INSTALL BOOT AND INSERT PUSH ROD

## INSTALLATION OF RELEASE CYLINDER

(See page [CL-10](#))

1. INSTALL RELEASE CYLINDER WITH TWO BOLTS

Torque: 12 N-m (120 kgf-cm, 9 ft-lbf)

2. CONNECT CLUTCH LINE UNION

Using SST, connect the union.

SST 09751-36011

3. BLEED CLUTCH SYSTEM

(See page [CL-4](#))

# CLUTCH UNIT COMPONENTS

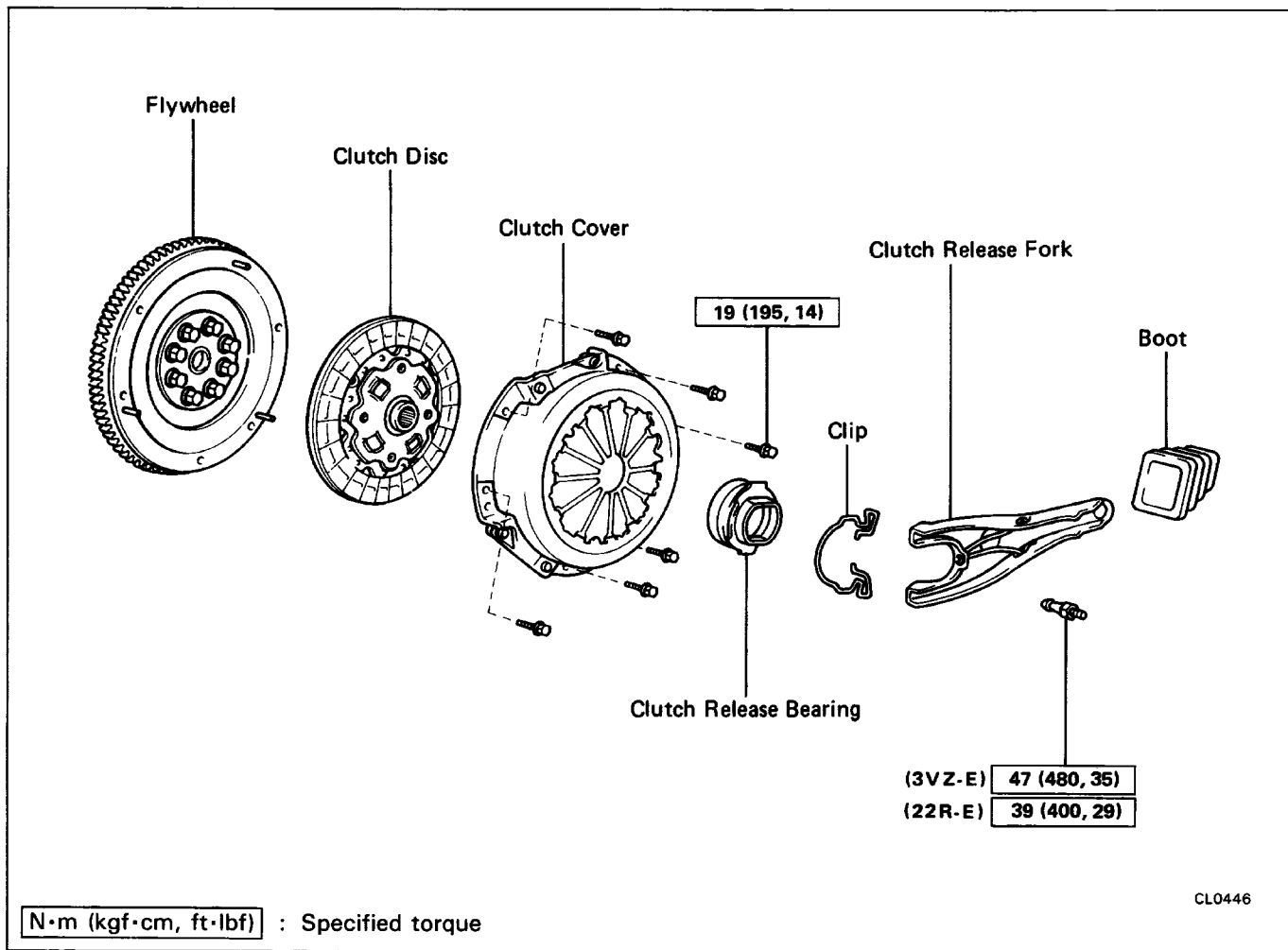

## REMOVAL OF CLUTCH UNIT

### 1. REMOVE TRANSMISSION (See pages MT-4, TF-5)

HINT: Do not drain the transmission oil.

### 2. REMOVE CLUTCH COVER AND DISC

- Put matchmarks on the clutch cover and flywheel.
- Loosen the set bolts one turn at a time until spring tension is released.
- Remove the set bolts and pull off the clutch cover and disc.

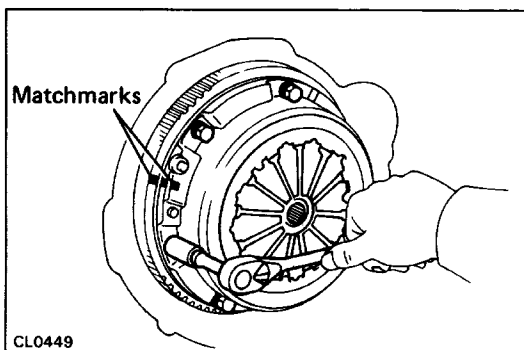

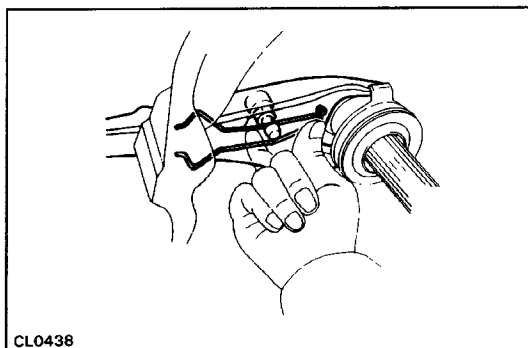

CL0438

### 3. REMOVE BEARING, HUB AND FORK FROM TRANSMISSION

- (a) Remove the retaining clip pull off the bearing.
- (b) Remove the fork and boot.

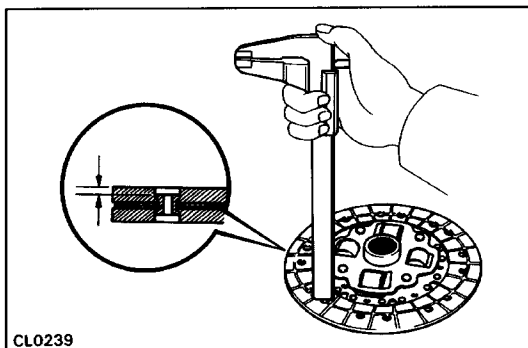

CL0239

### INSPECTION OF CLUTCH PARTS

#### 1. INSPECT CLUTCH DISC FOR WEAR OR DAMAGE

Using calipers, measure the rivet head depth.

**Minimum rivet depth: 0.3 mm (0.012 in.)**

If a problem is found, repair or replace the clutch disc.

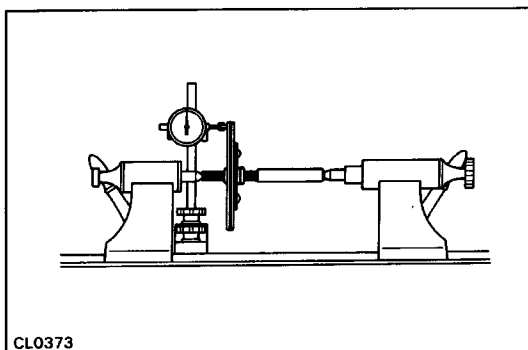

CL0373

#### 2. INSPECT CLUTCH DISC RUNOUT

Using a dial indicator, check the disc runout.

**Maximum runout: 0.8 mm (0.031 in.)**

If runout is excessive, replace the disc.

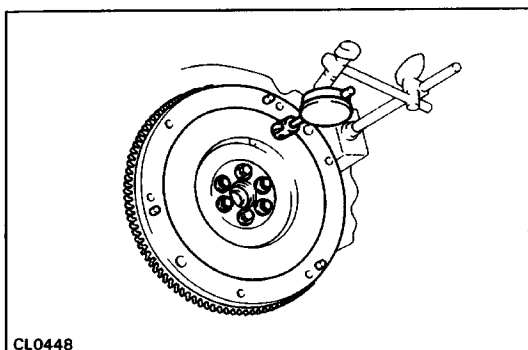

CL0448

#### 3. INSPECT FLYWHEEL RUNOUT

Using a dial indicator, check the flywheel runout.

**Maximum runout: 0.1 mm (0.004 in.)**

If runout is excessive, repair or replace flywheel.

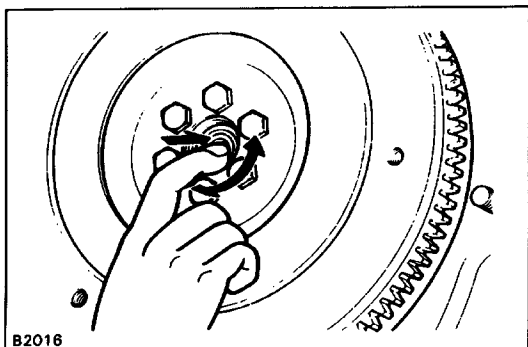

B2016

#### 4. INSPECT PILOT BEARING

Turn the bearing by hand while applying force in the rotation direction.

If the bearing sticks or has much resistance, replace the pilot bearing.

**HINT:** The bearing is permanently lubricated and requires no cleaning or lubrication.

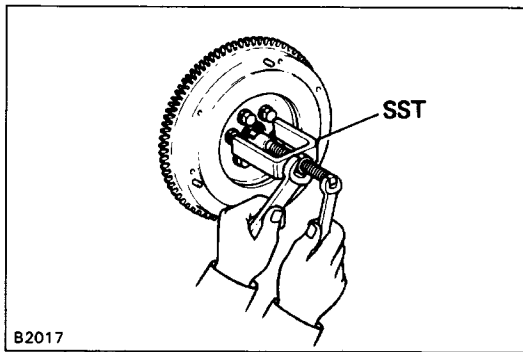

B2017

## 5. IF NECESSARY, REPLACE PILOT BEARING

(a) Using SST, remove the pilot bearing.

SST 09303-35011

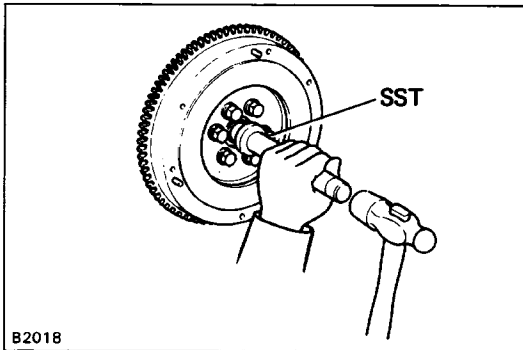

B2018

(b) Using SST, install the pilot bearing.

SST 09304-30012

HINT: After assembling the pilot bearing to the hud, insure that it rotates smoothly.

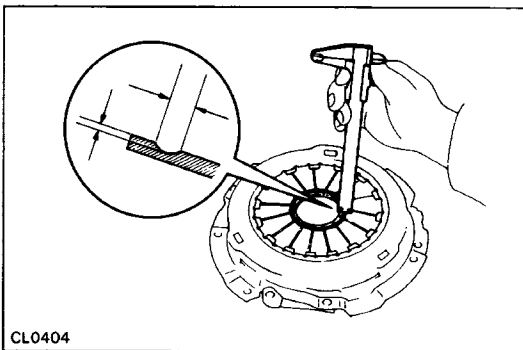

CL0404

## 6. INSPECT DIAPHRAGM SPRING FOR WEAR

Using calipers, measure the diaphragm spring for depth and width of wear.

**Maximum: Depth 0.6 mm (0.024 in.)**

**Width 5.0 mm (0.197 in.)**

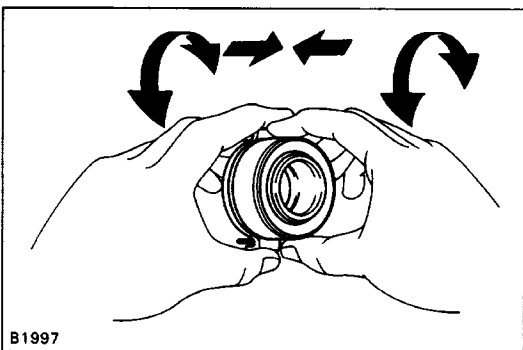

B1997

## 7. INSPECT RELEASE BEARING

Turn the bearing by hand while applying force in the rotation direction.

If the bearing sticks or has much resistance, replace the release bearing.

HINT: The bearing is permanently lubricated and requires no cleaning or lubrication.

## INSTALLATION OF CLUTCH UNIT

(See page CL-12)

### 1. INSTALL DISC ON FLYWHEEL

Using SST, install the disc on the flywheel.

SST 09301-20020

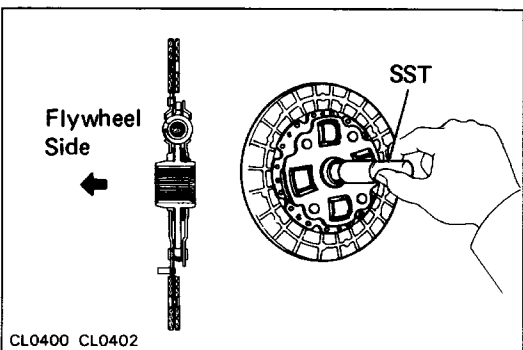

CL0400 CL0402

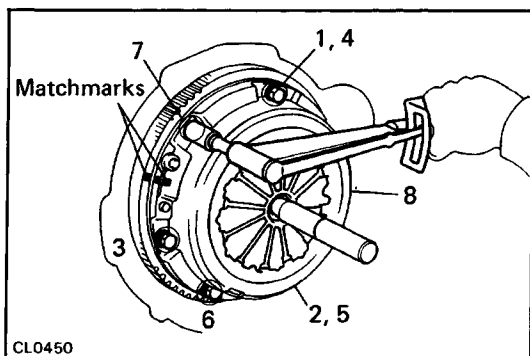

## 2. INSTALL CLUTCH COVER

- (a) Align the matchmarks on the clutch cover and fly-wheel.
- (b) Torque the bolts on the clutch cover in the order shown.

**Torque: 19 N-m (195 kgf-cm, 14 ft-lbf)**

**HINT:** Temporarily tighten the No. 1 and No. 2 bolts.

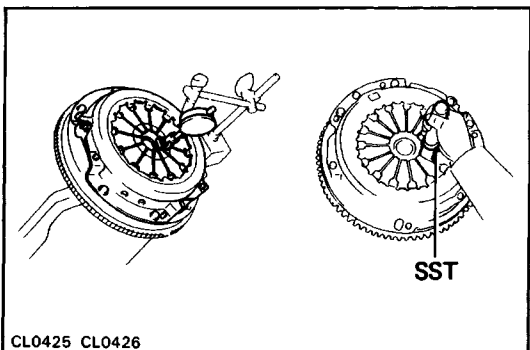

## 3. CHECK DIAPHRAGM SPRING TIP ALIGNMENT

Using a dial indicator with roller instrument, check the diaphragm spring tip alignment.

**Maximum non-alignment: 0.5 mm (0.020 in.)**

If alignment is not as specified, using SST, adjust the diaphragm spring tip alignment.

SST 09333-00013

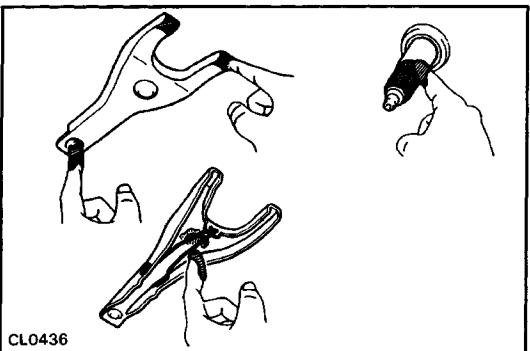

## 4. APPLY MOLYBDENUM DISULPHIDE LITHIUM BASE GREASE (NLGI NO.2) OR MP GREASE

Apply molybdenum disulphide lithium base grease to the following parts:

- Release fork and hub contact point
- Release fork and push rod contact point
- Release fork pivot point
- Clutch disc spline

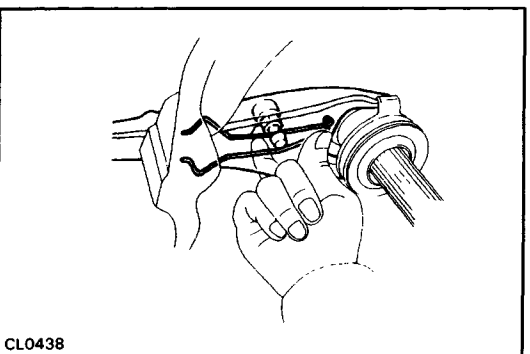

## 5. INSTALL BOOT, FORK, HUB AND BEARING ON TRANSMISSION

## 6. INSTALL TRANSMISSION

(See pages MT-5, TF-4)

# **G58, R150 and R150F MANUAL TRANSMISSION**



## DESCRIPTION

- Transmission types, G58, W55, W56, R150 and R1 50F are constant mesh synchronizers for forward gears and a sliding mesh reverse gear.
- The illustrations below show the engagements of transmission gears.

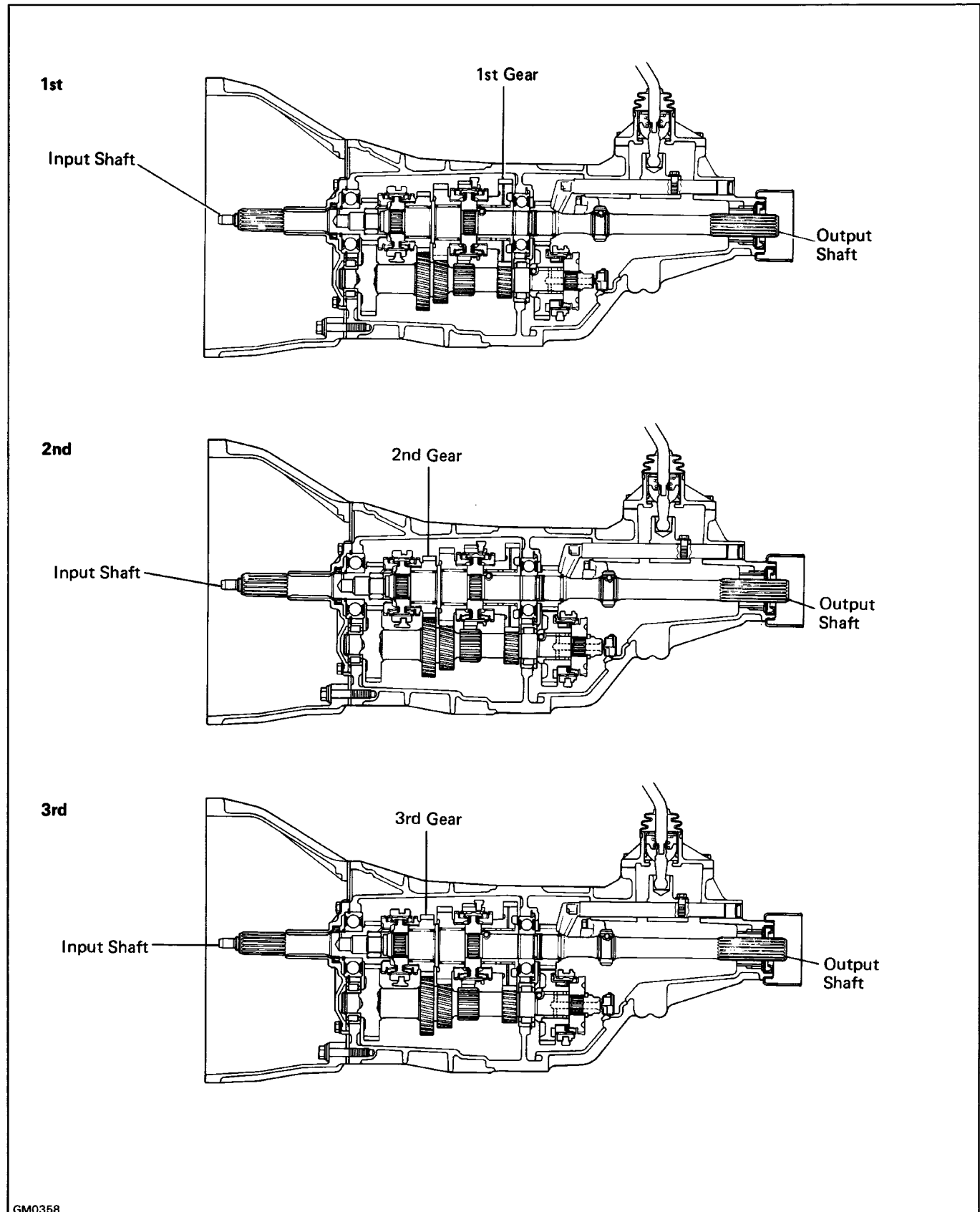

4th

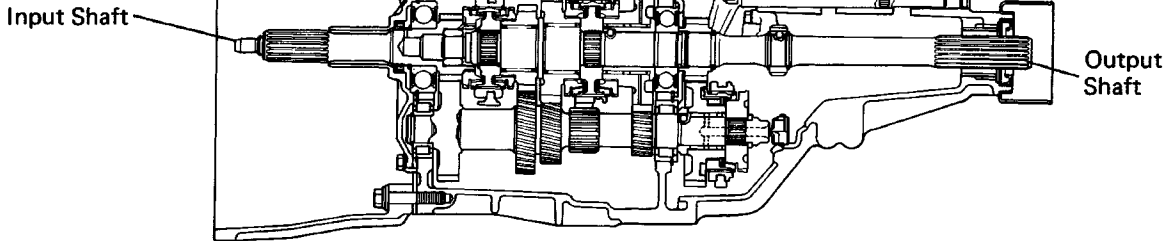

5th  
(5-Speed Only)

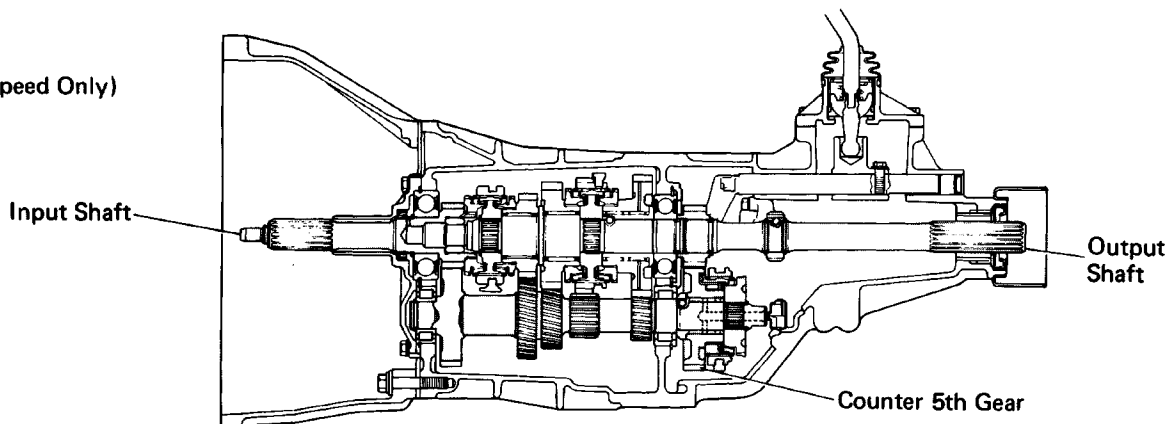

Rev.

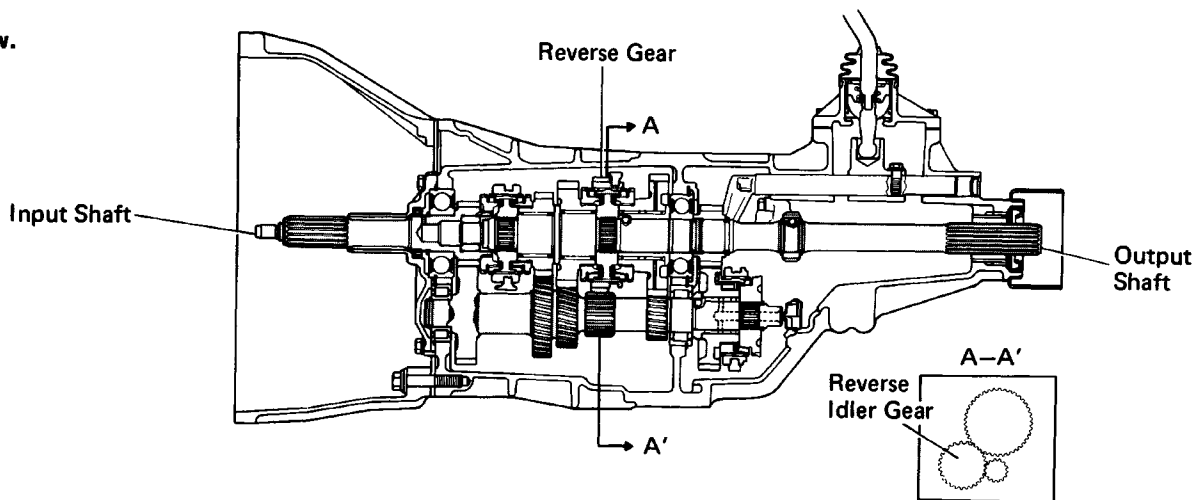

- The above illustrations show the engagements of a 5-speed transmission.
- The above illustration shows a G type transmission. The configuration of each gear is slightly different to W and R type transmissions but the gear engagements are the same.

## PRECAUTIONS

When working with FIPG material, you must observe the following.

- Using a razor blade and gasket scraper, remove all the old packing (FIPG) material from the gasket surfaces.
- Thoroughly clean all components to remove all the loose material.
- Clean both sealing surfaces with a non-residue solvent.
- Apply the seal packing in approx. 1 mm (0.04 in.) bead along the sealing surface.
- Parts must be assembled within 10 minutes of application. Otherwise, the packing (FIPG) material must be removed and reapplied.

## TROUBLESHOOTING

Problem	Possible cause	Remedy	Page
Hard to shift or will not shift	Splines on input shaft dirty or burred Transmission faulty	Repair as necessary Disassemble and inspect transmission	<a href="#">MT1-5</a> <a href="#">MT1-5</a>
Transmission jumps out of gear	Transmission faulty	Disassemble and inspect transmission	<a href="#">MT1-5</a>

# REMOVAL AND INSTALLATION OF TRANSMISSION (2WD)

## Remove and install the parts as shown

HINT: For the transmission with a transfer (4WD) refer to REMOVAL AND INSTALLATION OF TRANSMISSION WITH TRANSFER on Page MT1-14.

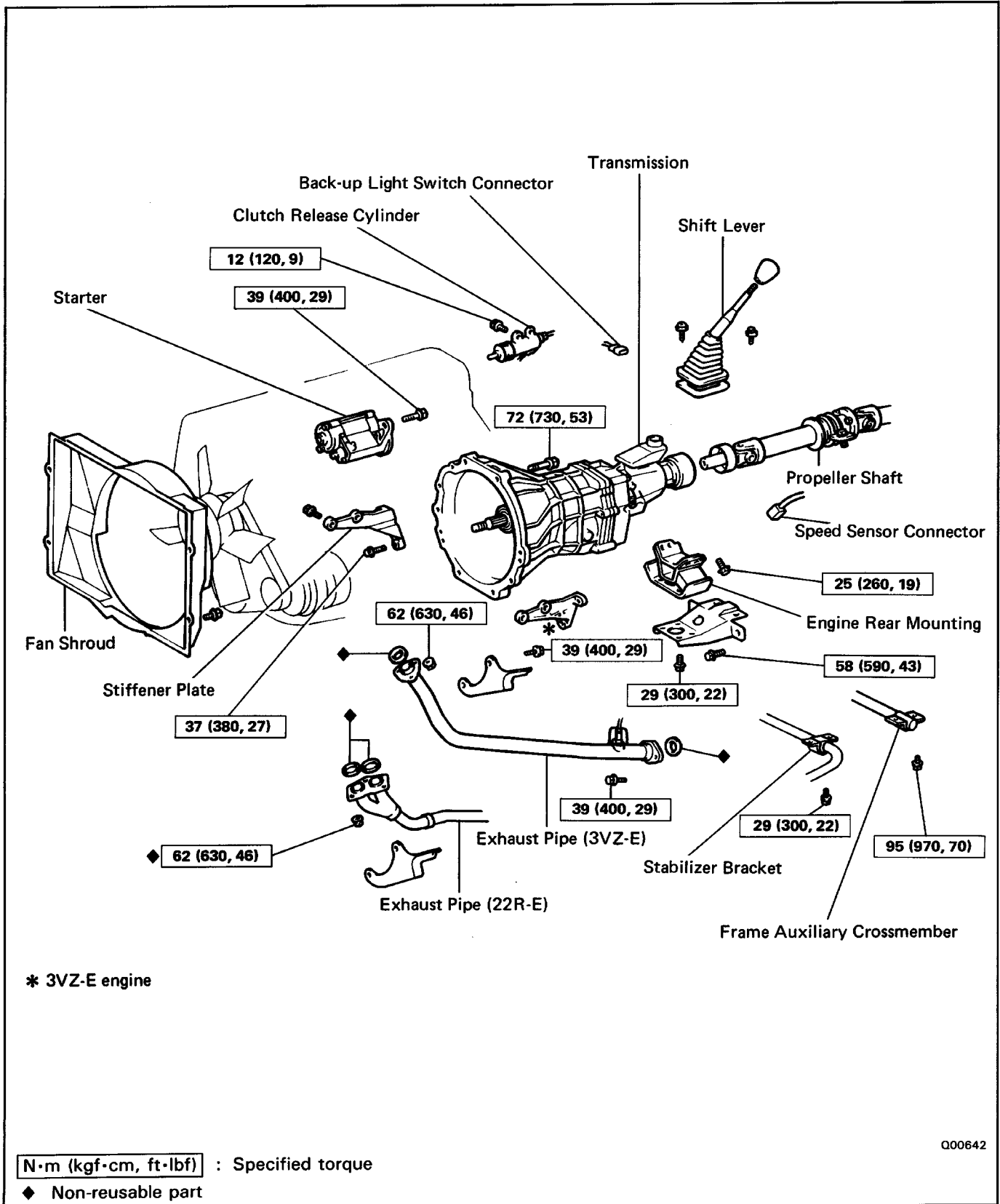

\* 3VZ-E engine

**N·m (kgf·cm, ft·lbf)** : Specified torque

◆ Non-reusable part

## REMOVAL OF TRANSMISSION

HINT: For the transmission with a transfer (4WD) refer to REMOVAL OF TRANSMISSION WITH TRANSFER on page MT1- 16.

### 1. DISCONNECT BATTERY CABLE FROM NEGATIVE TERMINAL

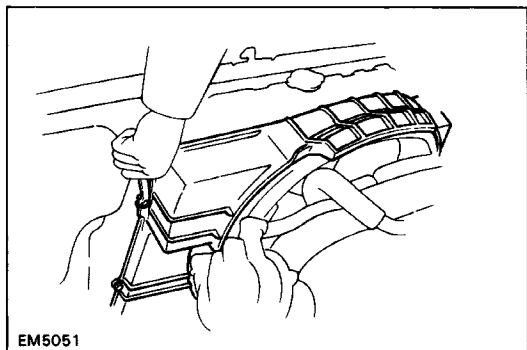

### 2. REMOVE FAN SHROUD SET BOLTS

Remove the four bolts.

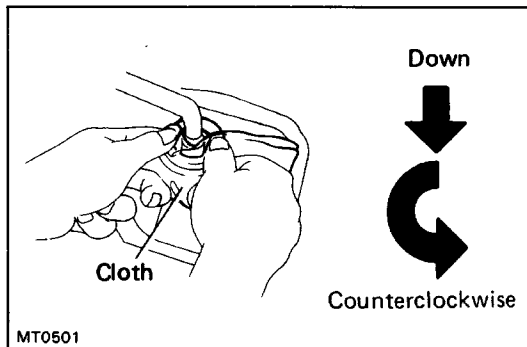

### 3. REMOVE TRANSMISSION SHIFT LEVER FROM INSIDE OF VEHICLE

- Remove the four screw and remove the shift lever boot retainer.
- Pull up the shift lever boot.
- Cover the shift lever cap with cloth.
- Then, pressing down on the shift lever cap, rotate it counterclockwise to remove.
- Remove the shift lever.

### 4. RAISE VEHICLE AND DRAIN TRANSMISSION OIL

**NOTICE:** Be sure the vehicle is securely supported.

### 5. DISCONNECT PROPELLER SHAFT

(SEE [PR-5](#))

SST 09325-20010 (22R-E)

09325-40010 ( 3V Z-E )

### 6. DISCONNECT SPEEDOMETER CABLE AND BACK-UP LIGHT SWITCH CONNECTOR

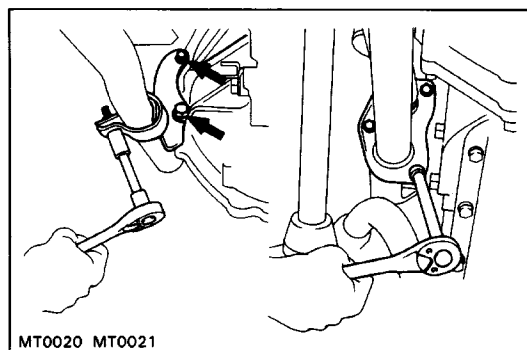

### 7.-1 (22R-E)

### REMOVE EXHAUST PIPE CLAMP AND EXHAUST PIPE

- Remove the exhaust pipe clamp from the bracket.
- Remove the exhaust pipe from the manifold.
- Remove the pipe clamp bracket from clutch housing.

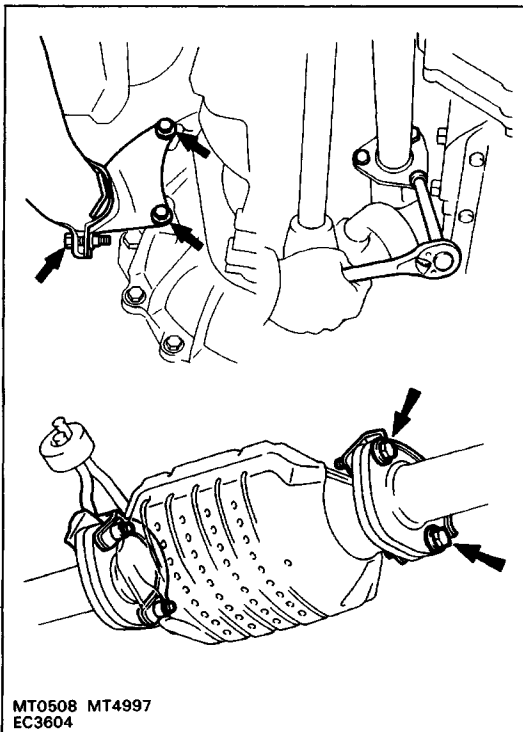
**7.-2 (3VZ-E)****REMOVE EXHAUST PIPE CLAMP AND EXHAUST PIPE**

- (a) Remove the exhaust pipe clamp from the bracket.
- (b) Remove the exhaust pipe bracket from the clutch housing.
- (c) Remove the exhaust pipe from the manifold.

- (d) Disconnect exhaust pipe from catalytic converter front side.

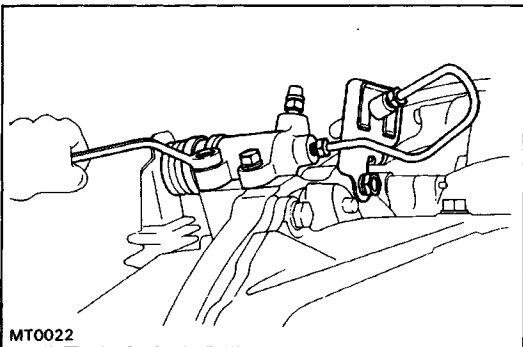
**8.-1 (22R-E)****REMOVE CLUTCH RELEASE CYLINDER, TUBE BRACKET AND STARTER LOWER MOUNTING BOLT**

Lay the release cylinder and tube bracket alongside the engine.

HINT: Do not disconnect the clutch line.

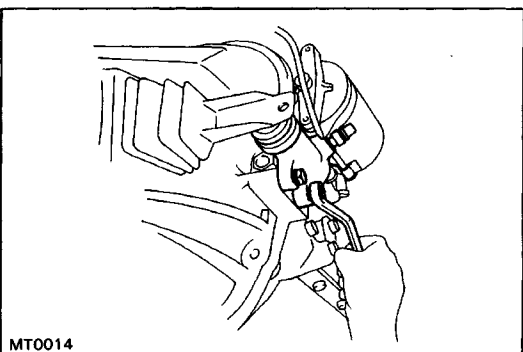
**8.-2 (3VZ-E)****REMOVE CLUTCH RELEASE CYLINDER**

Lay the release cylinder alongside engine.

HINT: Do not disconnect the clutch line.

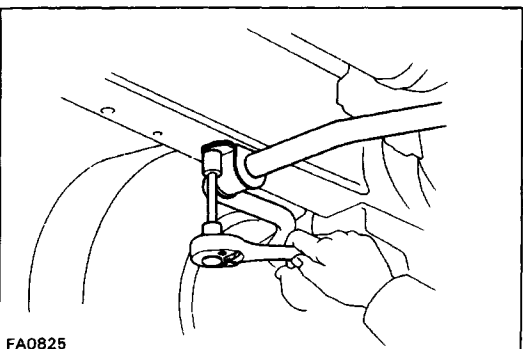
**9. REMOVE STABILIZER BRACKET SET BOLTS**

Remove the four bolts.

**10. REMOVE FRAME AUXILIARY CROSSMEMBER**

Remove the four bolts.

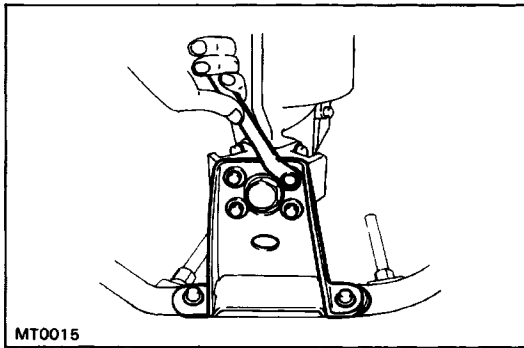

### 11. REMOVE ENGINE REAR MOUNTING AND BRACKET

- (a) Remove the four bolts from the engine rear mounting.
- (b) Raise the transmission slightly by raising the engine with a jack.

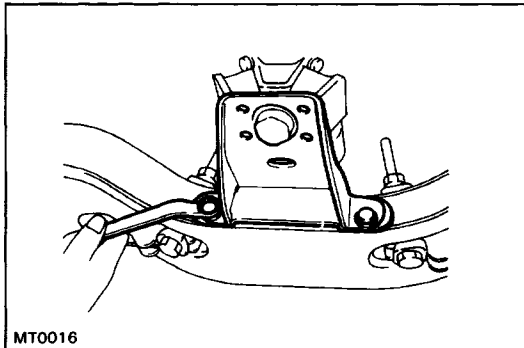

- (c) Remove the four bolts from the support member and remove the mounting bracket.

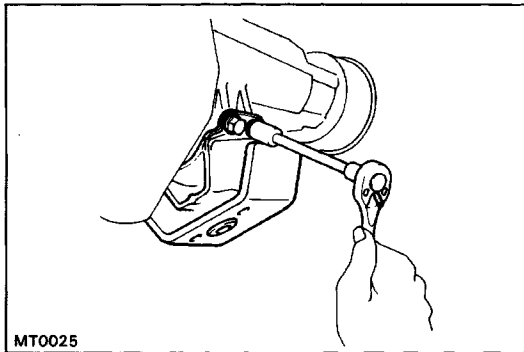

- (d) Remove the engine rear mounting from the transmission.

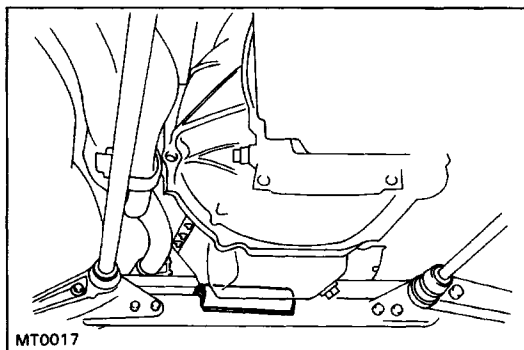

### 12. PLACE PIECE OF WOOD BETWEEN ENGINE OIL PAN AND FRONT CROSSMEMBER

HINT: Tape a piece of wood or such about 20 mm (0.79 in.) thick on the front crossmember.

### 13. LOWER TRANSMISSION

### 14. REMOVE STARTER

Lay the starter alongside the engine.

### 15. REMOVE STIFFENER PLATE BOLTS

### 16. REMOVE REMAINING TRANSMISSION BOLTS

**17. REMOVE TRANSMISSION**

- (a) Draw out the transmission toward the rear.
- (b) Lower the transmission front and remove the transmission from the vehicle.

HINT: Be careful not to damage the extension housing dust deflector.

**(3VZ-E/R 150 only)**

- (a) Turn the transmission clockwise about 45 degrees.
- (b) Slide the transmission toward the rear.
- (c) Lower the transmission front and remove the transmission from the vehicle.



# INSTALLATION OF TRANSMISSION

HINT: For the transmission with a transfer (4WD) refer to INSTALLATION OF TRANSMISSION WITH TRANSFER on page MT1-20.

## 1. PLACE TRANSMISSION AT INSTALLATION POSITION

Insert the extension housing between the member and floor and then slide the transmission forward.

Align the input shaft spline with the clutch disc, and push the transmission fully into position.

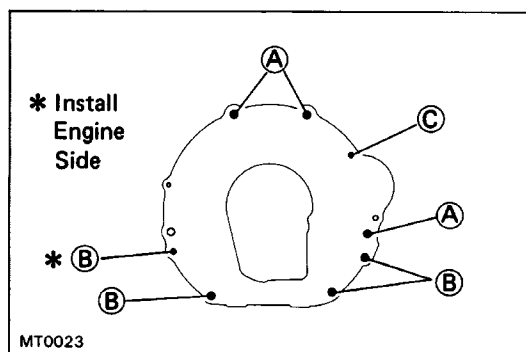

### 2.-1 (22R-E)

#### INSTALL TRANSMISSION BOLTS AND STIFFENER BOLTS AND STARTER

Torque:

- (A) Transmission mounting bolt  
72 N-m (730 kgf-cm, 53 ft-lbf)
- (B) Stiffener plate bolt  
37 N-m (380 kgf-cm, 27 ft-lbf)
- (C) Starter bolt 39 N-m (400 kgf-cm, 29 ft-lbf)

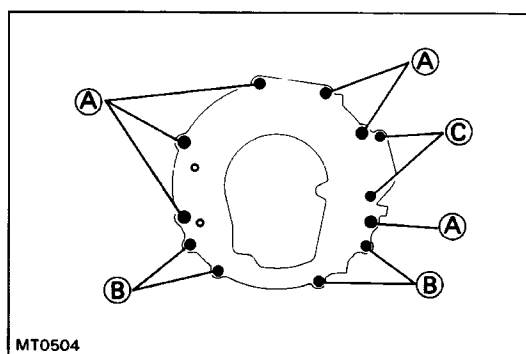

### 2.-2 (3VZ-E)

#### INSTALL TRANSMISSION BOLTS AND STIFFENER BOLTS

Torque:

- (A) Transmission mounting bolt  
72 N-m (730 kgf-cm, 53 ft-lbf)
- (B) Stiffener plate bolt  
37 N-m (380 kgf-cm, 27 ft-lbf)
- (C) Starter bolt 39 N-m (400 kgf-cm, 29 ft-lbf)

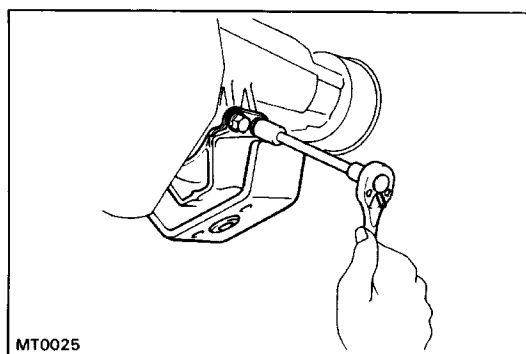

## 3. INSTALL ENGINE REAR MOUNTING AND BRACKET

(a) Install the engine rear mounting. Torque the bolts.

Torque: 25 N - m (260 kgf-cm, 19 ft-lbf)

(b) Raise the transmission slightly by raising the engine with a jack and a wooden block under the transmission.

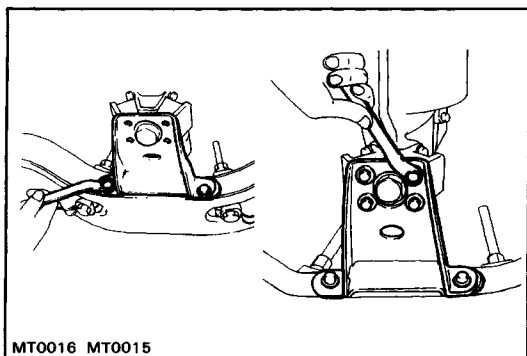

- (c) Install the engine rear mounting bracket to the support member. Torque the bolts.

**Torque: 59 N – m ( 590 kgf – cm, 43 ft – lbf )**

- (d) Lower the transmission and rest it on the extension housing.  
 (e) Install the bracket to the mounting. Torque the bolts.

**Torque: 29 N – m (300 kgf – cm, 22 ft – lbf )**

#### 4. REMOVE PIECE OF WOOD FROM FRONT CROSSMEMBER

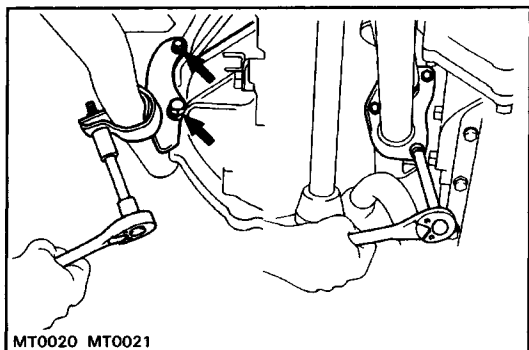

##### 5.-1(22R-E)

#### INSTALL EXHAUST PIPE, BRACKET AND CLAMP

- (a) Install the exhaust pipe to the manifold.  
**Torque: 62 N – m ( 630 kgf – cm, 46 ft – lbf )**  
 (b) Install the pipe bracket to the clutch housing.  
**Torque: Upper 19 N – m (195 kgf – cm, 14 ft– lbf )**  
**Lower 69 N – m (700 kgf – cm, 51 ft – lbf )**  
 (c) Install the exhaust pipe clamp.

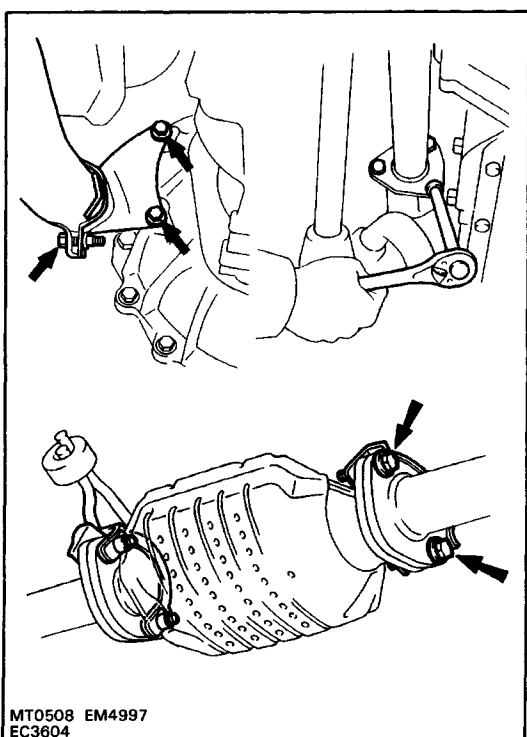

##### 5.-2 (3VZ-E)

#### INSTALL EXHAUST PIPE, BRACKET AND CLAMP

- (a) Install the exhaust pipe to the manifold.  
**Torque: 62 N – m (630 kgf – cm, 46 ft – lbf)**  
 (b) Connect exhaust pipe to catalytic converter front side.  
**Torque: 39 N – m (400 kgf – cm, 29 ft – lbf )**  
 (c) Install the pipe bracket to the clutch housing.  
**Torque: 39 N-m (400 kgf-cm, 29 ft-lbf )**  
 (d) Install the exhaust pipe clamp.

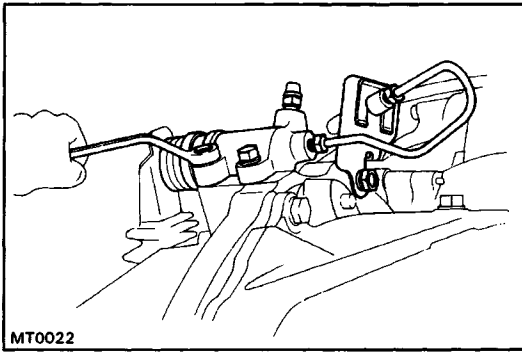

**6.-1 (22R-E)  
INSTALL STARTER LOWER MOUNTING BOLT AND  
CLUTCH RELEASE CYLINDER AND BRACKET**

**Torque:**

**Starter**

39 N-m (400 kgf-cm, 29 ft-lbf)

**Tube Bracket**

72 N-m (730 kgf-cm, 53 ft-lbf)

**Clutch Release Cylinder**

12 N-m (120 kgf-cm, 9 ft-lbf)

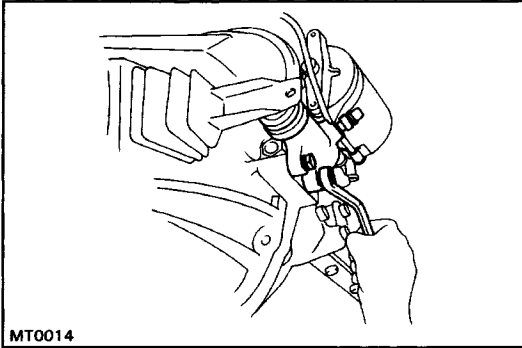

**6.-2(3VZ-E)  
INSTALL CLUTCH RELEASE CYLINDER**

**Torque:**

**Clutch Release Cylinder**

12 N-m (120 kgf-cm, 9 ft-lbf)

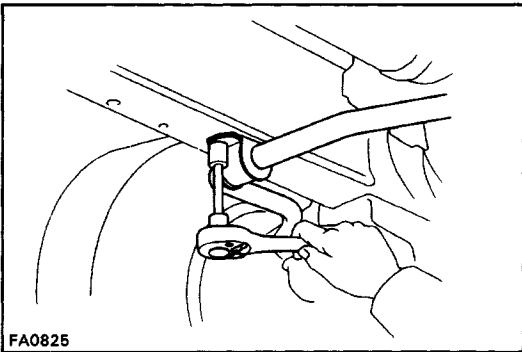

**7. INSTALL STABILIZER BRACKET SET BOLTS**

Install and torque the four bolts.

**Torque: 29 N-m (300 kgf-cm, 22 ft-lbf)**

**8. INSTALL FRAME AUXILIARY CROSSMEMBER**

Install and torque the four bolts.

**Torque: 95 N-m (970 kgf-cm, 70 ft-lbf)**

**9. CONNECT SPEEDOMETER CABLE AND BACK-UP  
LIGHT SWITCH**

**10. CONNECT PROPELLER SHAFT**

(See page [PR-15](#))

**11. FILL TRANSMISSION WITH OIL**

Transmissions Items	R 150	W55
Oil grade	API GL-4 or GL-5	API GL-4 or GL5
Viscosity	SEA 75W-90	SEA75W-90 or 80W-90
Transmission oil capacity	3.0 liters (3.2 US qts 2.6 Imp. qts)	2.4 liters (2.5 US qts 2.1 Imp. qts)

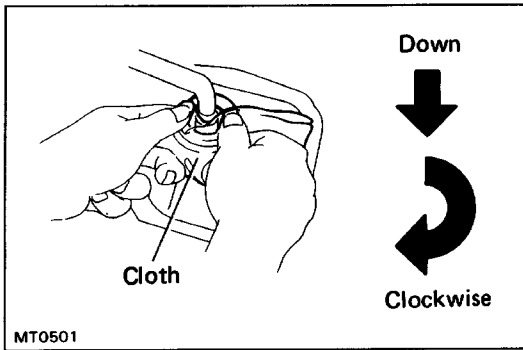
**12. LOWER VEHICLE****13. INSTALL SHIFT LEVER**

- (a) Apply MP grease to the shift lever.
- (b) Align the groove of the shift lever cap and the pin part of case cover.
- (c) Cover the shift lever cap with a cloth.
- (d) Then, pressing down on the shift lever cap, rotate it clockwise to install.
- (e) Install the shift lever boot and retainer with four screws.

**14. INSTALL FAN SHROUD SET BOLTS**

Install and torque the four bolts.

**15. CONNECT BATTERY CABLE TO NEGATIVE TERMINAL****16. PERFORM ROAD TEST**

Check for abnormal noise and smooth operation.

# REMOVAL AND INSTALLATION OF TRANSMISSION WITH TRANSFER (4WD)

## REMOVAL AND INSTALLATION OF TRANSMISSION WITH TRANSFER

Remove and install the parts as shown.

### [22R-E] W56 Transmission and Counter Gear Type Transfer

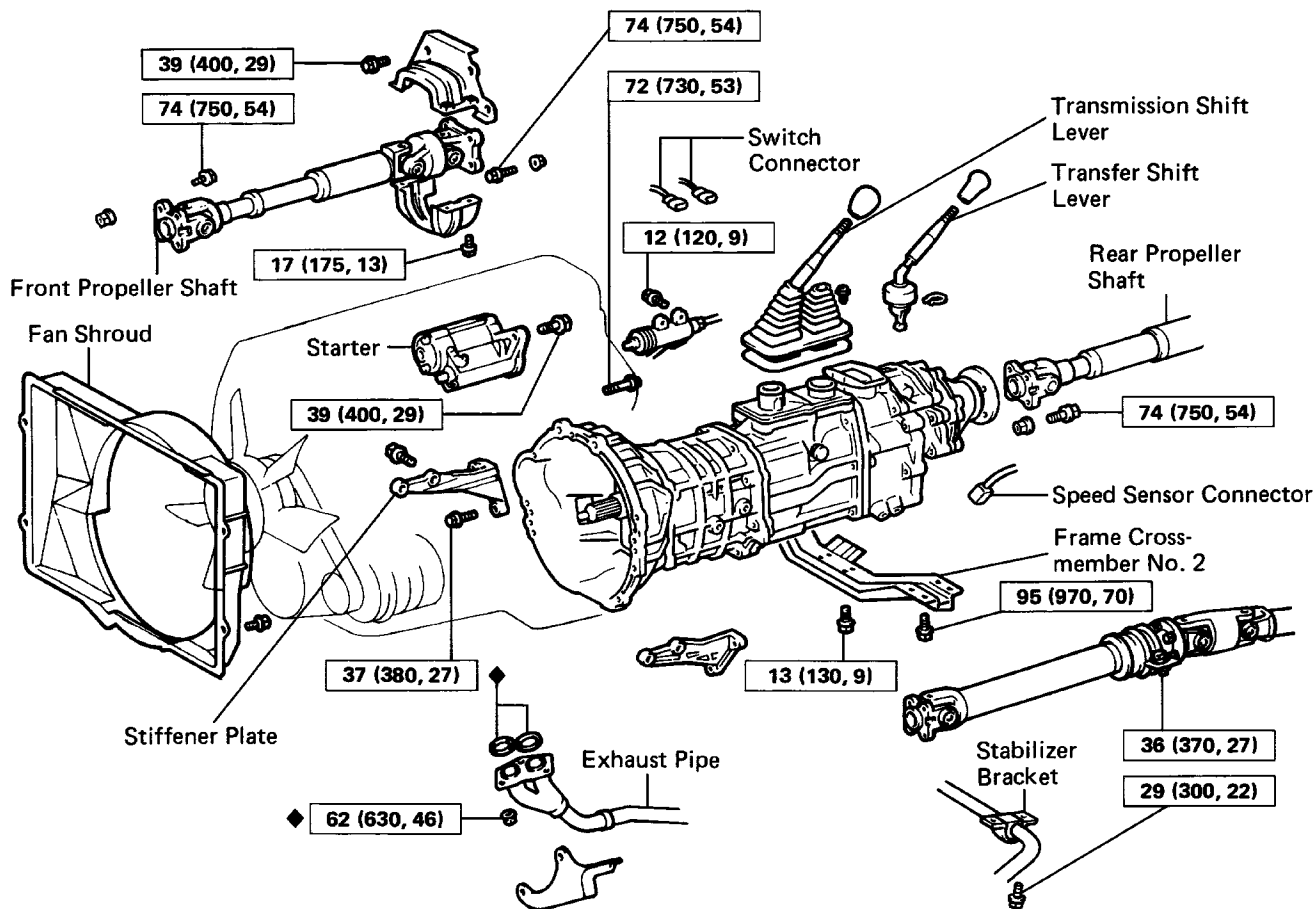

### G58 Transmission and Planetary Gear Type Transfer

\*1 To transfer  
\*2 To bracket

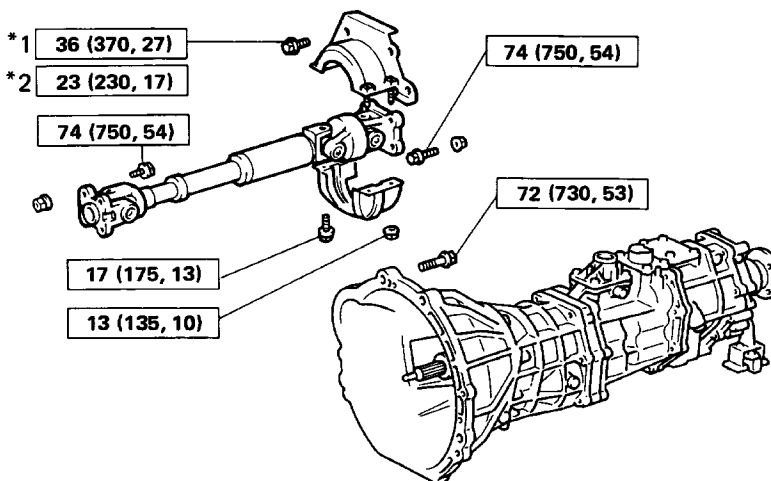

**N·m (kgf·cm, ft·lbf)** : Specified torque

◆ Non-reusable part

# REMOVAL AND INSTALLATION OF TRANSMISSION WITH TRANSFER (Cont'd)

Remove and install the parts as shown.

[3VZ-E] R150F Transmission and Planetary Gear Type Transfer

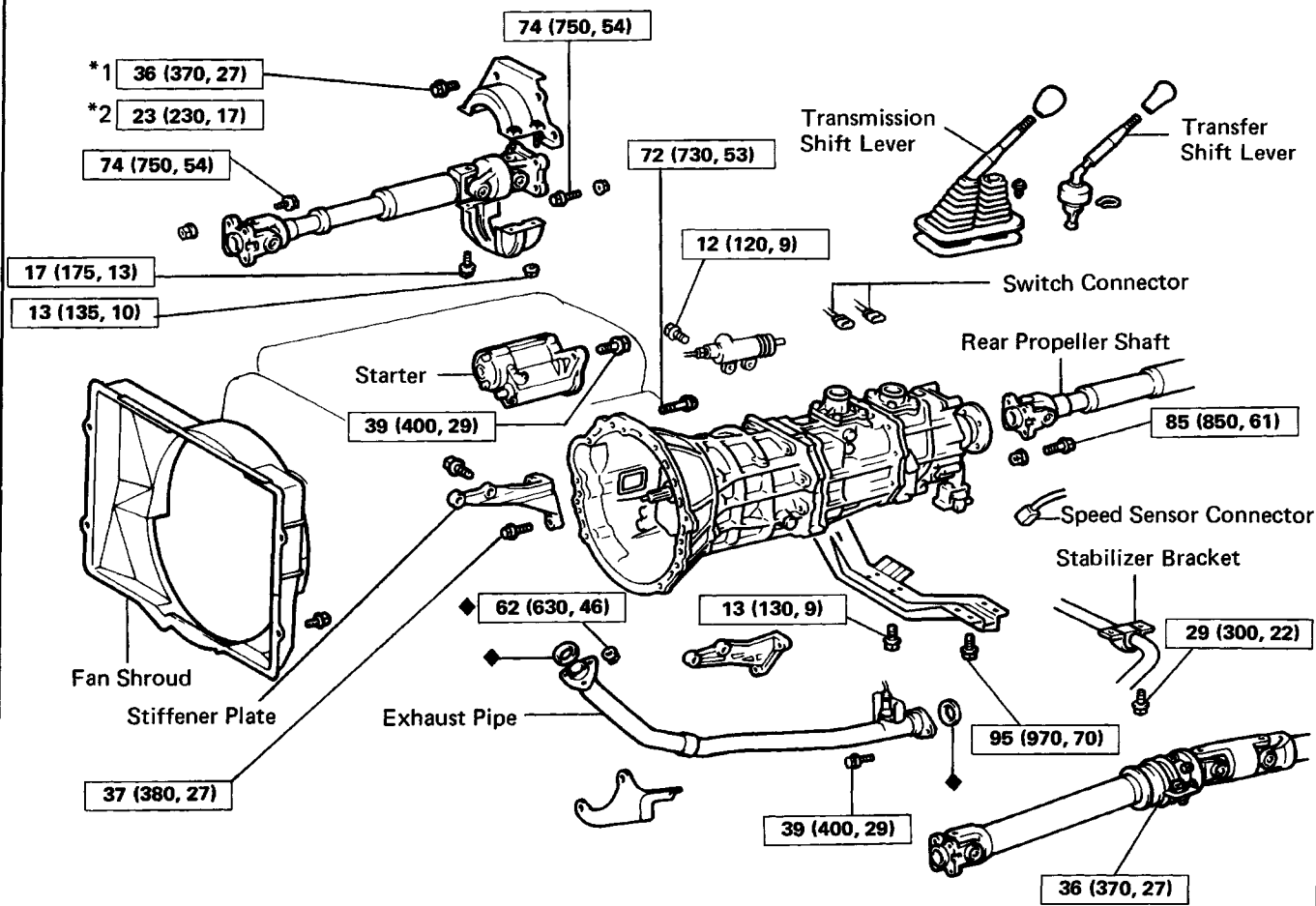

\*1 To transfer  
\*2 To bracket

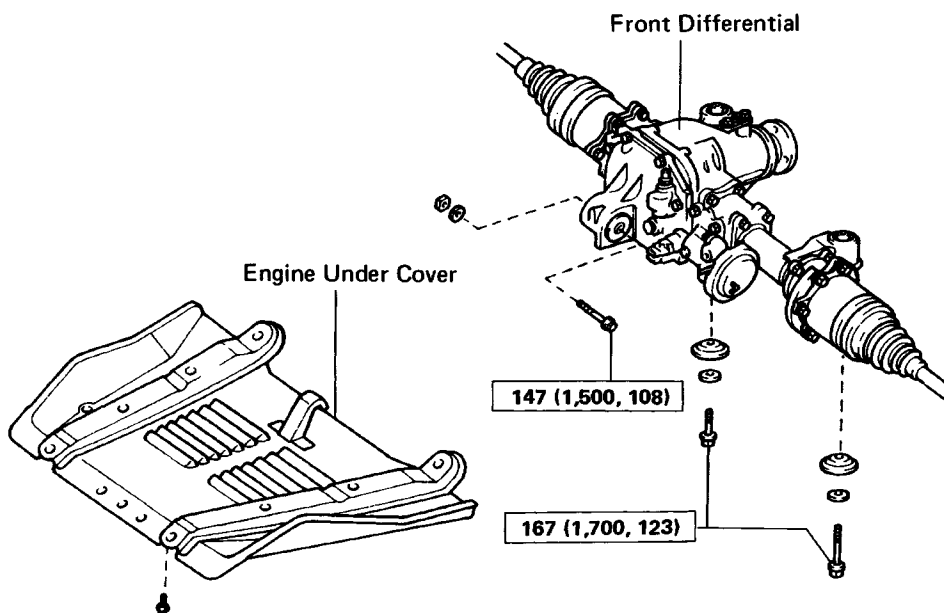

N·m (kgf·cm, ft·lbf) : Specified torque

◆ Non-reusable part

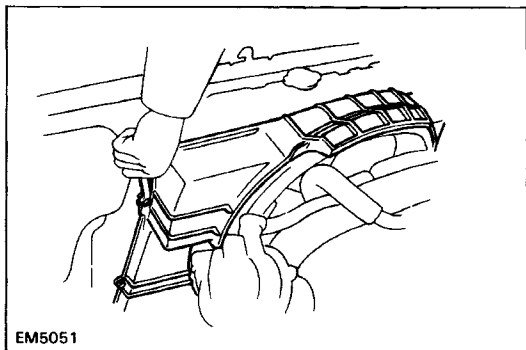

EM5051

## REMOVAL OF TRANSMISSION WITH TRANSFER

**1. DISCONNECT BATTERY CABLE FROM NEGATIVE TERMINAL**

**2. REMOVE FAN SHROUD SET BOLTS**

Remove the four bolts.

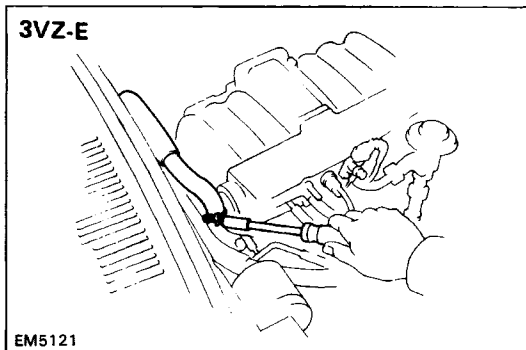

EM5121

**3. ( 3 VZ-E )**

**REMOVE HEATER HOSE CLAMP**

(a) Loosen clamp bolt.

(b) Move the clamp upside.

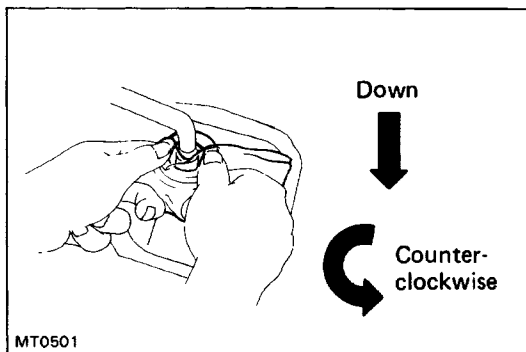

MT0501

**4. REMOVE TRANSMISSION SHIFT LEVER FROM INSIDE OF VEHICLE**

(a) Remove the four screws and remove the shift lever boot retainer.

(b) Pull up the shift lever boot.

(c) Cover the shift lever cap with cloth.

(d) Then, pressing down on the shift lever cap, rotate it counterclockwise to remove.

(e) Remove the shift lever.

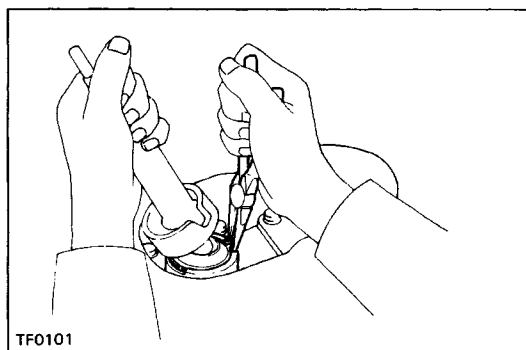

TF0101

**5. REMOVE TRANSFER SHIFT LEVER FROM INSIDE OF VEHICLE**

Using pliers, remove the snap ring and pull out the shift lever from the transfer.

**6. RAISE VEHICLE AND DRAIN TRANSMISSION AND TRANSFER OIL**

**NOTICE:** Be sure the vehicle is securely supported.

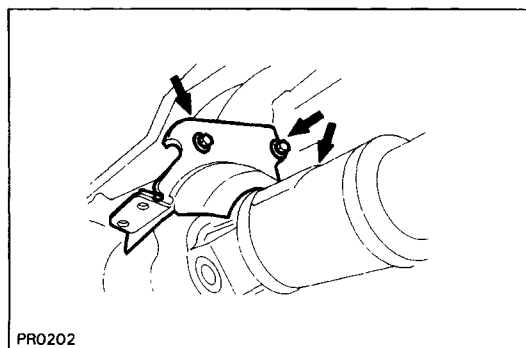

PR0202

**7. ( R 150F, G58 )**

**REMOVE PROPELLER SHAFT DUST COVER SUBASSEMBLY**

Remove the three bolts and cover.

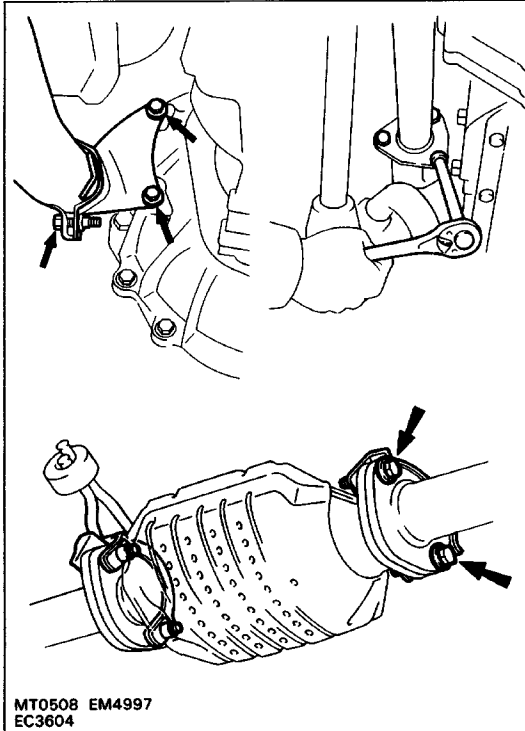
**8. DISCONNECT PROPELLER SHAFT**(See page [PR-5](#))**9. DISCONNECT SPEEDOMETER CABLE, BACK-UP LIGHT SWITCH CONNECTOR AND TRANSFER INDICATOR SWITCH CONNECTOR****10.-1(3VZ-E)****REMOVE EXHAUST PIPE, BRACKET AND CLAMP**

- (a) Remove exhaust pipe clamp.
- (b) Remove exhaust pipe bracket from clutch housing.
- (c) Remove exhaust pipe from exhaust manifold.

- (d) Disconnect exhaust pipe from catalytic converter front side.

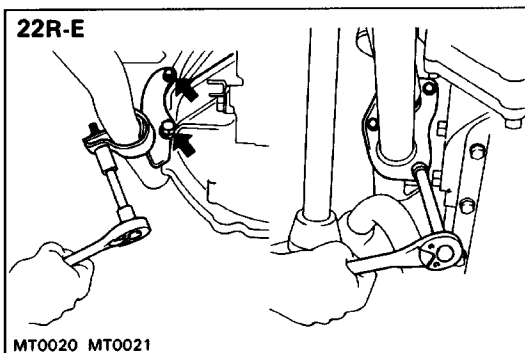
**10.-2 (22R-E)****REMOVE EXHAUST PIPE CLAMP AND EXHAUST PIPE**

- (a) Remove exhaust pipe clamp.
- (b) Remove exhaust pipe from exhaust manifold.

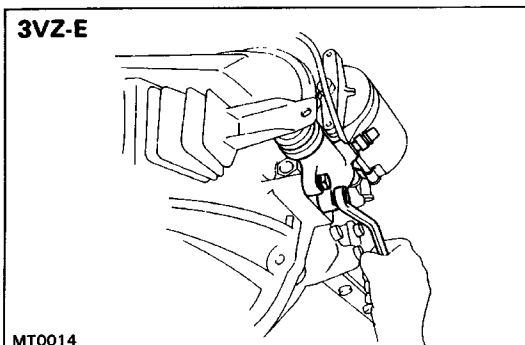
**11.-1 (3VZ-E)****REMOVE CLUTCH RELEASE CYLINDER**

Lay the release cylinder alongside the engine.

**HINT:** Do not disconnect the clutch line.

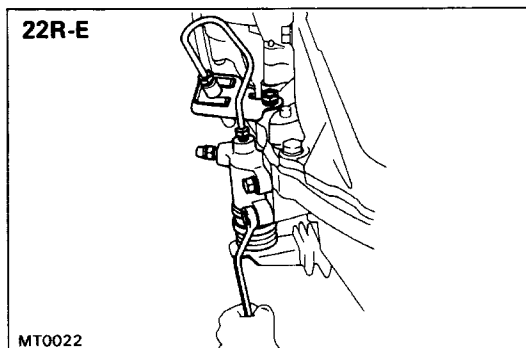

**11.-2 (22R-E)****REMOVE CLUTCH RELEASE CYLINDER, TUBE BRACKET**

Remove the mounting bolts and lay the cylinder alongside the engine.

HINT: Do not disconnect the clutch line.

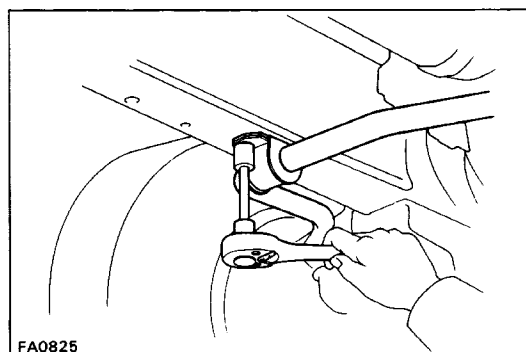
**12. (3VZ-E)****REMOVE THE FRONT DIFFERENTIAL SET BOLTS**

(a) Remove the three bolts.

(b) Support the front differential.

**13. REMOVE THE STABILIZER BRACKET SET BOLTS**

Remove four bolts.

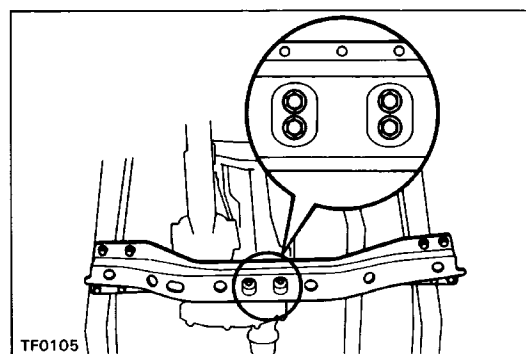
**14. REMOVE NO.2 FRAME CROSSMEMBER FROM SIDE FRAME**

(a) Remove the four bolts from the engine rear mounting.

(b) Raise the transmission slightly with a jack.

(c) Remove the eight bolts from the side frame and remove the No.2 frame crossmember.

**15. (22R-E)****PLACE PIECE OF WOOD BETWEEN ENGINE OIL PAN AND FRONT AXLE****16. LOW TRANSMISSION WITH TRANSFER****17. REMOVE STARTER**

(a) Remove the two bolts.

(b) Lay the starter alongside the engine.

**18. REMOVE EXHAUST PIPE BRACKET AND STIFFENER PLATE BOLTS****19. REMOVE REMAINING TRANSMISSION BOLTS****20. REMOVE TRANSMISSION WITH TRANSFER**

(a) Draw out the transmission with the transfer toward the rear.

(b) Lower the transmission with the transfer front and remove it from the vehicle.

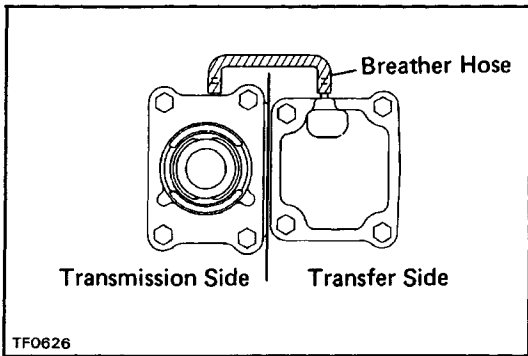

**21. (22R-E/G58)**

**REMOVE BREATHER HOSE**

Disconnect the breather hose from transfer upper cover and transmission control retainer.

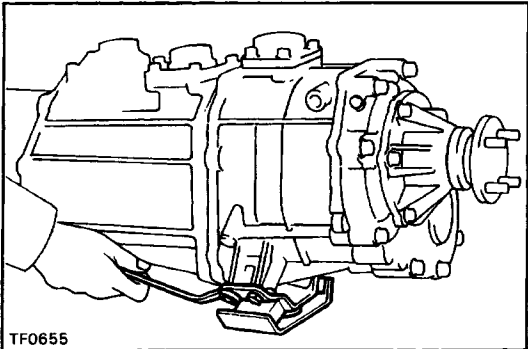

**22. REMOVE ENGINE REAR MOUNTING**

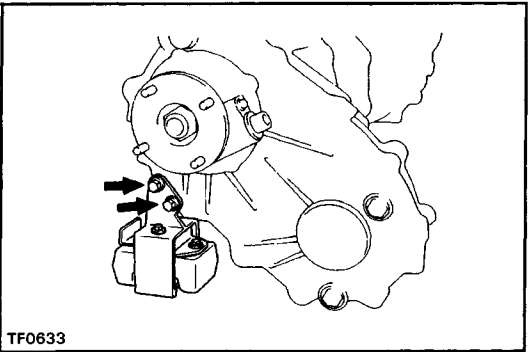

**23. (Regular Cab w/ Planetary Gear Type Transfer)**

**REMOVE DYNAMIC DAMPER**

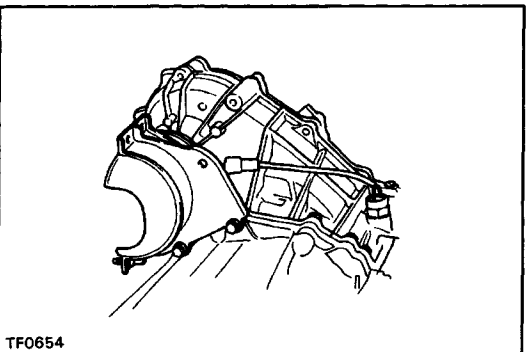

**24. REMOVE PROPELLER SHAFT UPPER DUST COVER AND**

**TRANSFER FROM TRANSMISSION**

- (a) Remove the dust cover bolt from the bracket.
- (b) Remove the transfer adaptor rear mounting bolts.

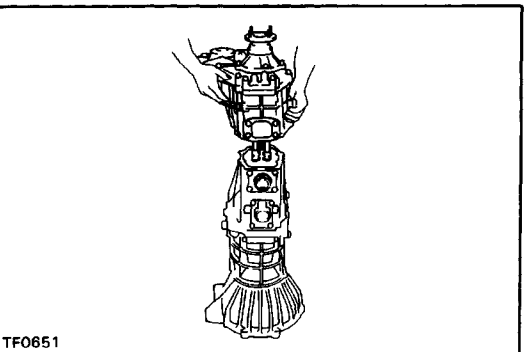

- (c) Pull the transfer straight up and remove it from the transmission.

HINT: Take care not to damage the adaptor rear oil seal with the transfer input gear spline.

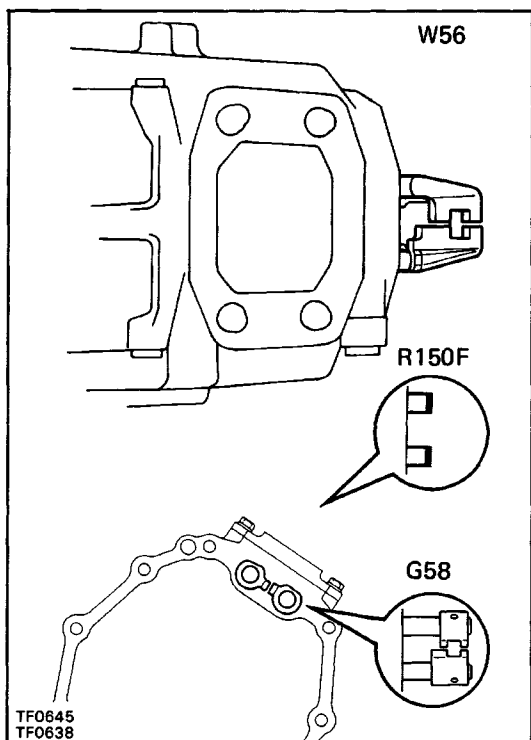

## INSTALLATION OF TRANSMISSION WITH TRANSFER

### 1. INSTALL TRANSFER AND PROPELLER SHAFT UPPER DUST COVER TO TRANSMISSION WITH NEW GASKET

- (a) Shift the two shift fork shafts to the high-four position.

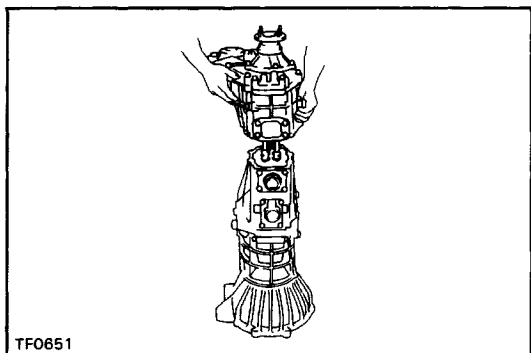

- (b) Apply MP grease to the adaptor oil seal.  
 (c) Place a new gasket to the transfer adaptor.  
 (d) Install the transfer to the transmission.

HINT: Take care not to damage the oil seal by the input gear spline when installing the transfer.

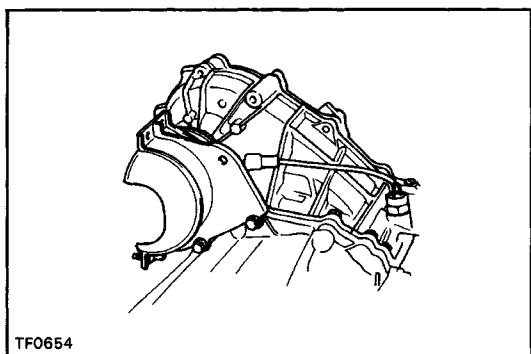

- (e) Install and torque the bolts with the propeller shaft upper dust cover.

#### Torque:

W56	39 N-m (400 kgf-cm, 29 ft-lbf)
R150F, G58	37 N-m (380 kgf-cm, 27 ft-lbf)

- (f) Install the dust cover bolt to the bracket.

#### Torque:

R150F, G58	23 N-m (230 kgf-cm, 17 ft-lbf)
W56	39 N-m (400 kgf-cm, 29 ft-lbf)

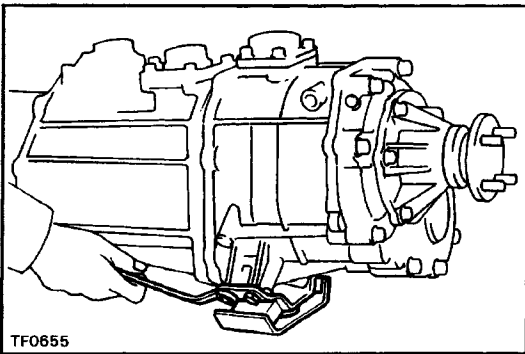

**2. INSTALL ENGINE REAR MOUNTING**

Torque: 25 N-m (260 kgf-cm, 19 ft-lbf)

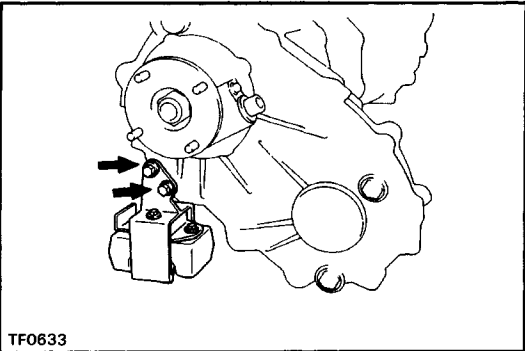

**3. (Regular Cab w/ Planetary Gear Type Transfer)  
INSTALL DYNAMIC DAMPER**

Torque: 37 N-m (380 kgf-cm, 27 ft-lbf)

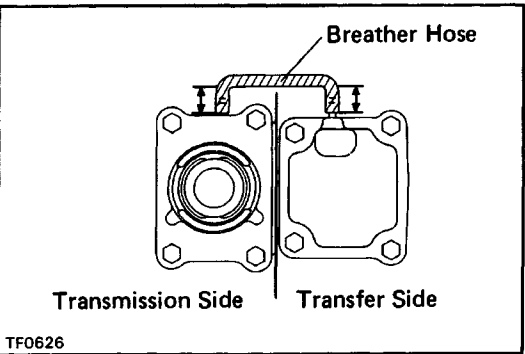

**4. ( 22R-E/G 58)  
INSTALL BREATHER HOSE**

Connect the breather hose for transfer upper cover and transmission control retainer as shown.

**Hose depth: 13 mm (0.51 in.)**

**5. PLACE TRANSMISSION WITH TRANSFER AT  
INSTALLATION POSITION**

- (a) Support the transmission with a jack.
- (b) Align the input shaft spline with the clutch disc, and push the transmission with the transfer fully into position.

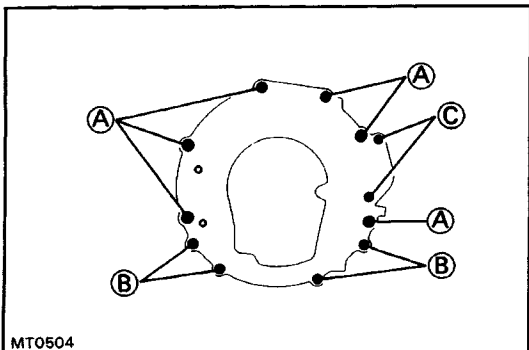

**6.-1 (3VZ-E)  
INSTALL TRANSMISSION BOLTS, STIFFENER BOLTS  
AND STARTER**

Torque:

- (A) Transmission bolt  
72 N-m (730 kgf-cm, 53 ft-lbf)
- (B) Stiffener plate bolt  
37 N-m (380 kgf-cm, 27 ft-lbf)
- (C) Starter bolt  
39 N-m (400 kgf-cm, 29 ft-lbf)

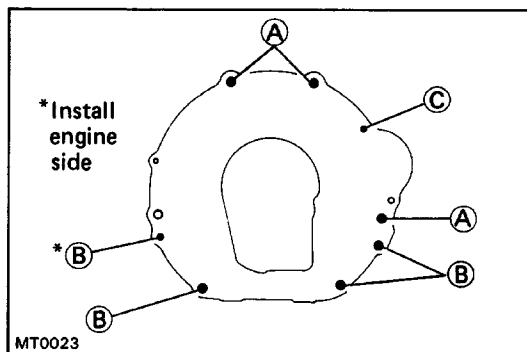
**6.-2(22R-E)****INSTALL TRANSMISSION BOLTS AND STIFFENER BOLTS****Torque:**

- (A) Transmission bolt  
72 N-m (730 kgf-cm, 53 ft-lbf)
- (B) Stiffener plate bolt  
37 N-m (380 kgf-cm, 27 ft-lbf)
- (C) Starter bolt  
39 N-m (400 kgf-cm, 29 ft-lbf)

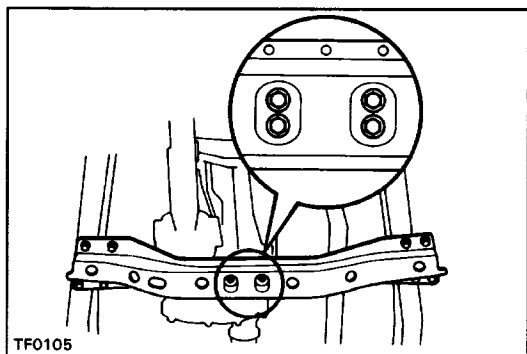
**7. INSTALL NO.2 FRAME CROSSMEMBER**

- (a) Raise the transmission slightly with a jack.
- (b) Install the No.2 frame crossmember to the side frame with the bolts. Torque the bolts.  
**Torque: 95 N-m (970 kgf-cm, 70 ft-lbf)**
- (c) Lower the transmission and transfer.
- (d) Install the four mounting bolts to the engine rear mounting. Torque the bolts.  
**Torque: 13 N-m (130 kgf-cm, 9 ft-lbf)**

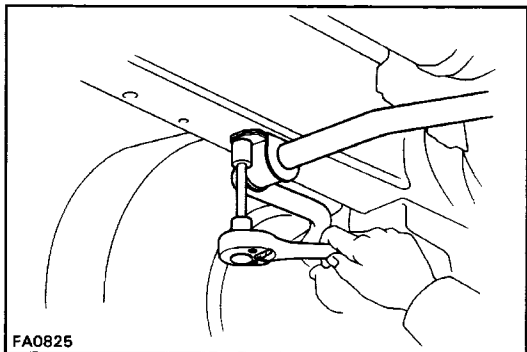
**8. INSTALL STABILIZER BRACKET SET BOLTS****Torque: 29 N-m (300 kgf-cm, 22 ft-lbf)****9.(22R-E)****REMOVE PIECE OF WOOD FROM FRONT AXLE****10. (3VZ-E)****INSTALL THE FRONT DIFFERENTIAL ASSEMBLY**

Install and torque the three bolts.

**Torque:**

- Differential carrier cover to frame**  
147 N-m (1500 kgf-cm, 108 ft-lbf)
- Others**  
167 N-m (1700 kgf-cm, 123 ft-lbf)

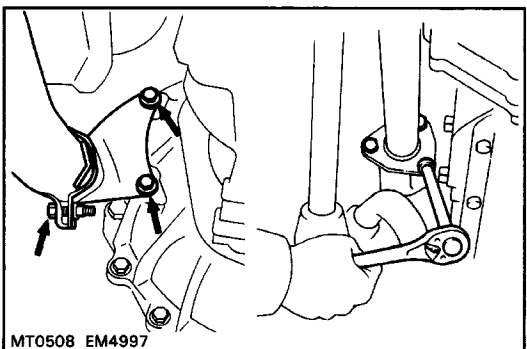
**11.-1(3VZ-E)****INSTALL EXHAUST PIPE, BRACKET AND CLAMP**

- (a) Install exhaust pipe to the manifold.  
**Torque: 62 N-m (630 kgf-cm, 46 ft-lbf)**
- (b) Install exhaust pipe bracket to the clutch housing.  
**Torque: 39 N-m (400 kgf-cm, 29 ft-lbf)**
- (c) Install exhaust pipe clamp.  
**Torque: 19 N-m (195 kgf-cm, 14 ft-lbf)**

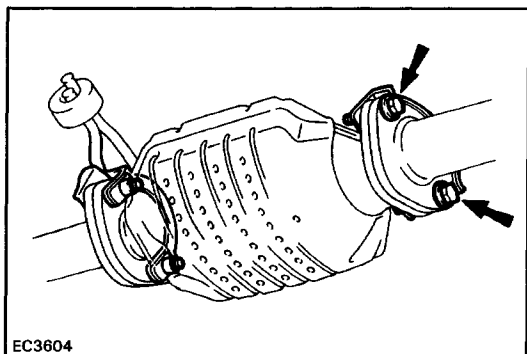

- (d) Connect the exhaust pipe to the catalytic converter front side, and torque the bolts.

**Torque: 39 N . m (400 kgf-cm, 29 ft-lbf)**

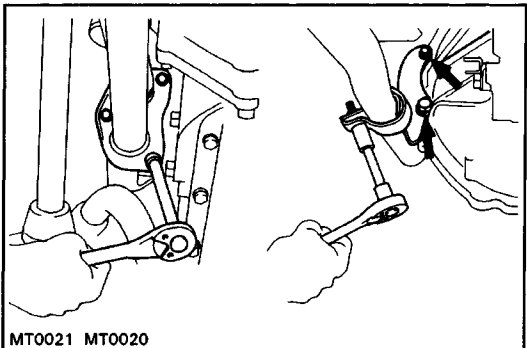

### 11.-2(22R-E)

#### INSTALL EXHAUST PIPE, BRACKET AND CLAMP

- (a) Install the exhaust pipe to the manifold.

**Torque: 62 N - m (630 kgf - cm, 46 ft - lbf)**

- (b) Install the pipe bracket to the clutch housing.  
Torque the bolts.

**Torque: Upper 19 N-m (195 kgf-cm, 14 ft -lbf)**

**Lower 69 N - m (700 kgf - cm, 51 ft - lbf )**

- (c) Install the exhaust pipe clamp.

**Torque: 19 N - m 1195 kgf - cm, 14 ft - lbf)**

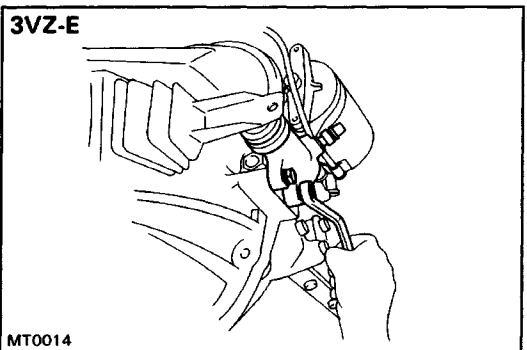

### 12.-1(3VZ-E)

#### INSTALL CLUTCH RELEASE CYLINDER

- Install clutch release cylinder and torque the two bolts.

**Torque: 12 N - m (120 kgf - cm, 9 ft - lbf )**

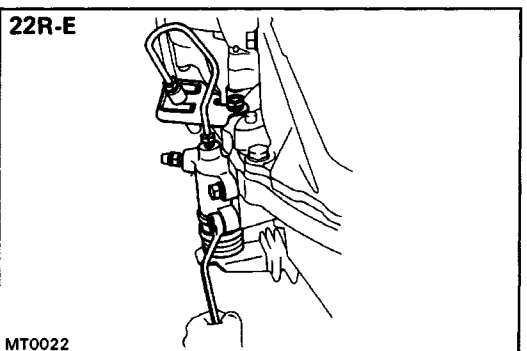

### 12.-2(22R-E)

#### INSTALL STARTER MOUNTING BOLTS, CLUTCH RELEASE CYLINDER AND TUBE BRACKET

- (a) Install tube bracket and torque the starter lower mounting bolt and nut.

**Torque: 39 N - m (400 kgf - cm, 29 ft - lbf)**

- (b) Install clutch release cylinder and torque the two bolts.

**Torque: 12 N - m (120 kgf - cm, 9 ft - lbf)**

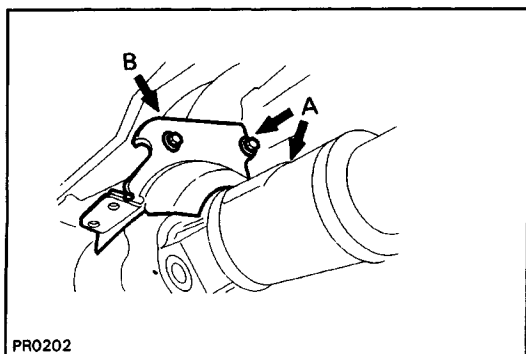

### 13.(R150F, G58)

#### INSTALL PROPELLER SHAFT DUST COVER SUBASSEMBLY

- (a) Install the cover.

- (b) Install and torque the three bolts.

**Torque:**

**A-bolt 36 N - m (370 kgf - cm, 27 ft-lbf )**

**B-bolt 23 N - m (230 kgf - cm, 17 ft - lbf )**

**14. CONNECT SPEEDOMETER CABLE, BACK-UP LIGHT SWITCH CONNECTOR AND TRANSFER INDICATOR SWITCH CONNECTOR**

**15. CONNECT PROPELLER SHAFT**

(See page PR-15)

**16. FILL TRANSMISSION AND TRANSFER WITH OIL**

(Transmission oil)

TIM (Engine) Items	R150F (3VZ-E)	G58 (22R-E)	W56 (22R-E)
Oil grade	API GL-4 or GL-5	API GL-4 or GL-5	API GL-4 or GL-5
Viscosity	SAE 75W-90	SAE 75W-90	SAE 75W-90 or 80W-90
Oil capacity	3.0 liters (3.2 US qts.) (2.6 Imp. qts.)	3.9 liters (4.1 US qts.) (3.4 Imp. qts.)	3.0 liters (3.2 US qts.) (2.6 Imp. qts.)

(Transfer oil)

TIM (Engine) Items	R 150F (3VZ-E)	G58 (22R-E)	W56 (22R-E)
Oil grade	API GL-4 or GL-5	API GL-4 or GL-5	API GL-4 or GL-5
Viscosity	SAE 75W-90	SAE 75W-90	SAE 75W-90
Oil capacity	1.1 liters (1.2 US qts.) (1.0 Imp. qts.)	1.1 liters (1.2 US qts.) (1.0 Imp. qts.)	1.6 liters (1.7 US qts.) (1.4 Imp. qts.)

**17. LOWER VEHICLE**

**18.-1(R 150F, G58)**

**INSTALL TRANSFER SHIFT LEVER**

- (a) Apply MP grease to the transfer shift lever.
- (b) Install the shift lever as shown.
- (c) Using pliers, install snap ring.

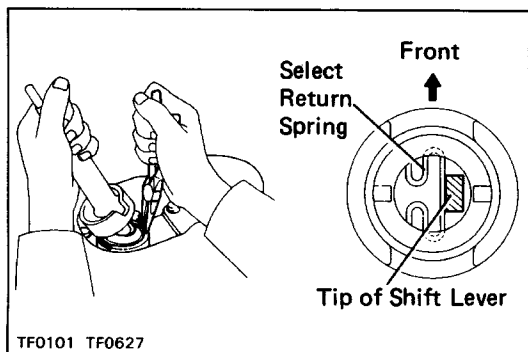

TF0101 TF0627

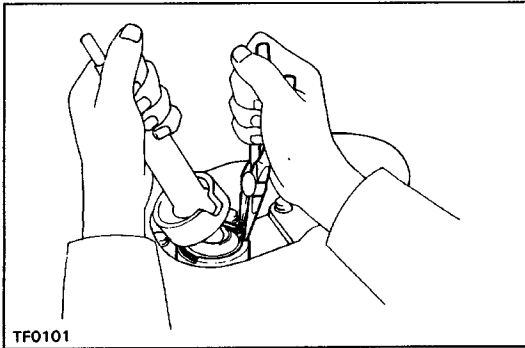
**18.-2(W56)****INSTALL TRANSFER SHIFT LEVER**

- (a) Apply MP grease to the transfer shift lever.
- (b) Using pliers, install the shift lever and snap ring.

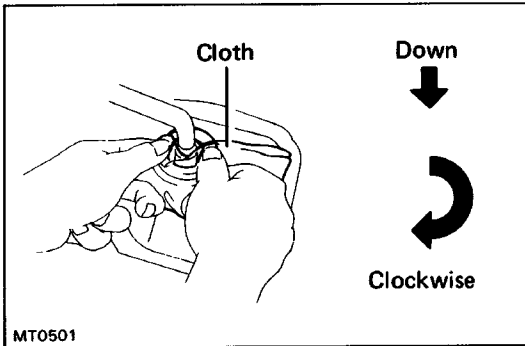
**19. INSTALL TRANSMISSION SHIFT LEVER**

- (a) Apply MP grease to the transmission shift lever.
- (b) Align the groove of the shift lever cap and the pin part of the case cover.
- (c) Cover the shift lever cap with a cloth.
- (d) Then, pressing down on the shift lever cap, rotate it clockwise to install.

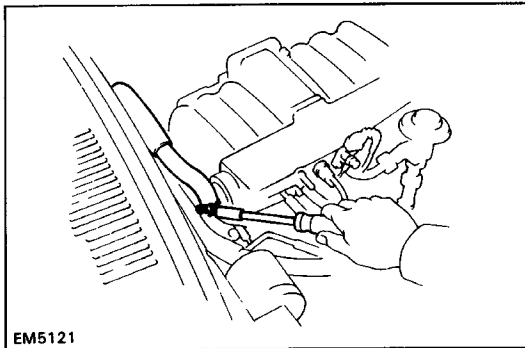
**20. (3VZ-E)****INSTALL HEATER HOSE CLAMP,**

- (a) Move the clamp to correct position.
- (b) Torque the clamp bolt.

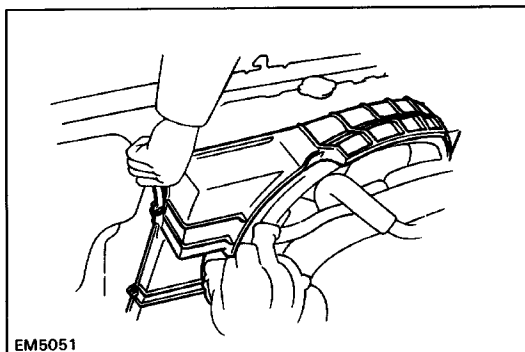
**21. INSTALL FAN SHROUD SET BOLTS**

Install and torque the four bolts.

**22. CONNECT BATTERY CABLE TO NEGATIVE TERMINAL****23. PERFORM ROAD TEST**

Check for abnormal noise and smooth operation.



# DISASSEMBLY OF TRANSMISSION (G58 TRANSMISSION) Components

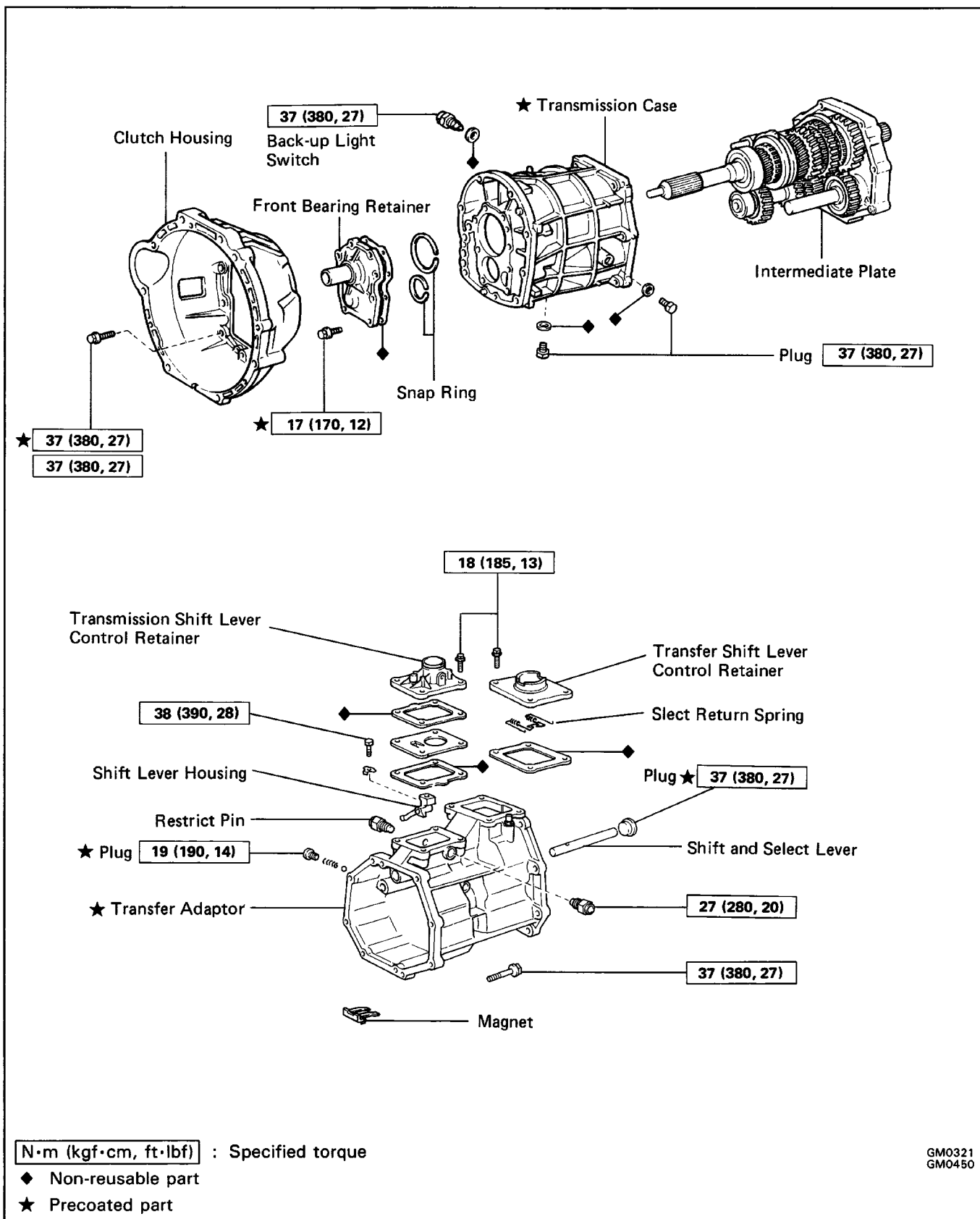

# Components (Cont'd)

2WD

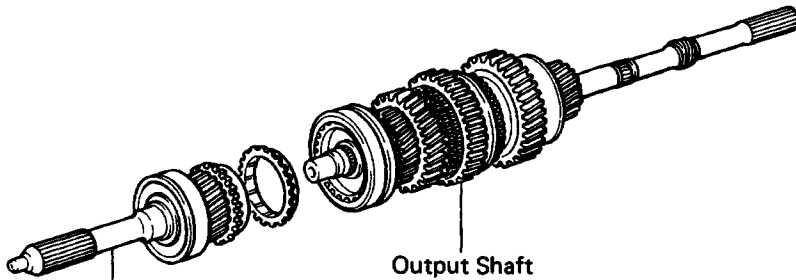

Output Shaft

4WD

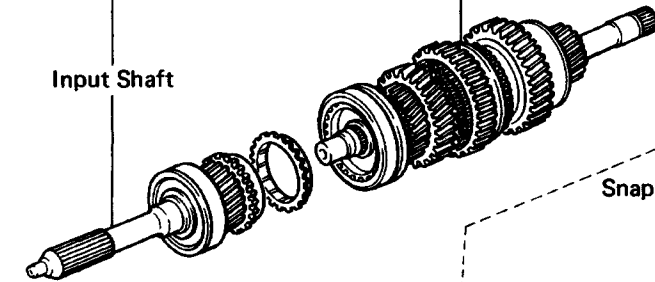

Input Shaft

18 (185, 13)

Snap Ring

Snap Ring

Bearing

Rear Bearing Retainer

Intermediate Plate

Counter Gear

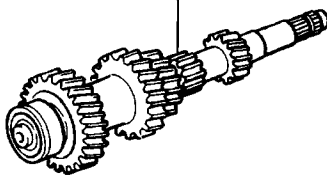

Gear Spline Piece No. 5

Bearing

Counter 5th Gear

Snap Ring

Ball

Snap Ring

Spacer

Synchronizer Ring

Reverse Idler Gear



17 (175, 13)

Reverse Idler Gear Shaft

N·m (kgf·cm, ft·lbf) : Specified torque

# Components (Cont'd)

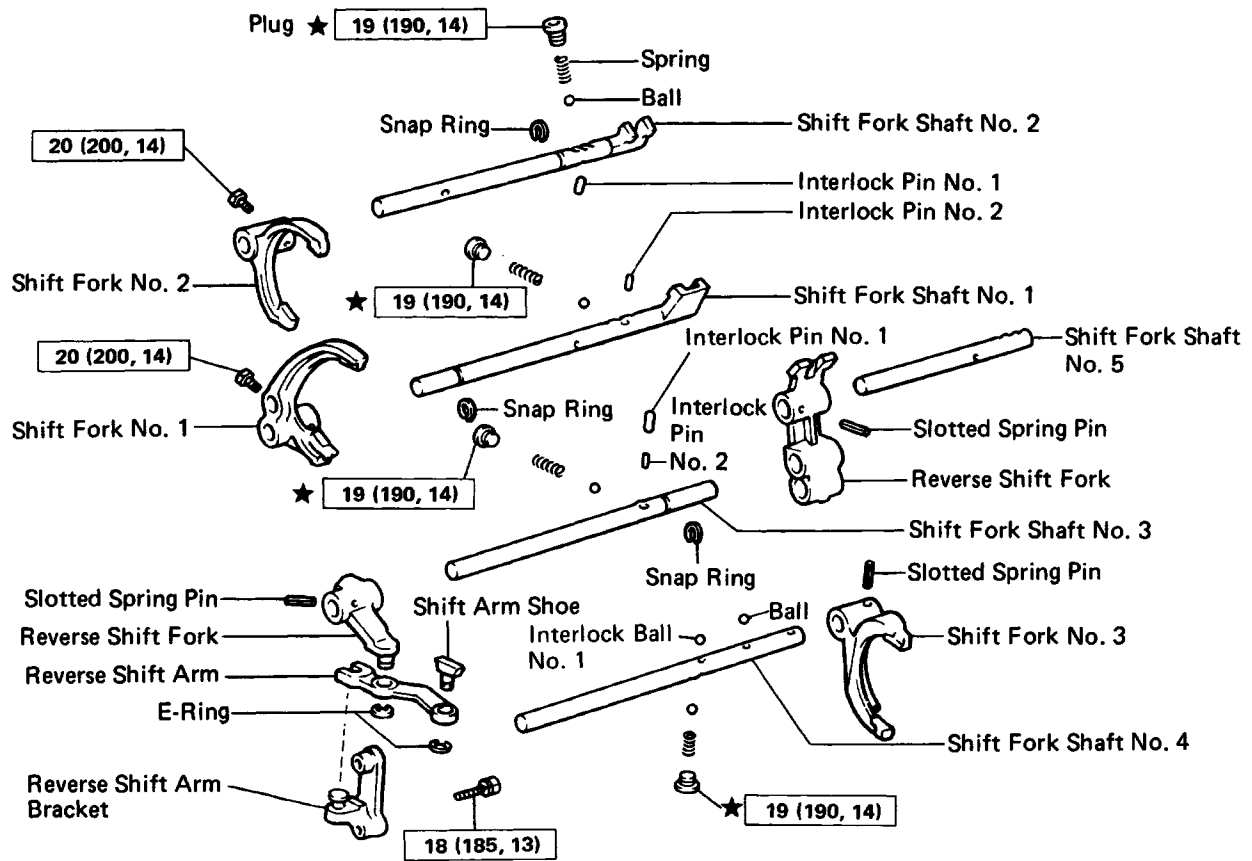

**N·m (kgf·cm, ft·lbf)** : Specified torque

★ Precoated part

# Disassembly of Transmission

(See pages [MT1–26](#) to 28)

1. REMOVE RELEASE FORK AND BEARING
2. REMOVE BACK-UP LIGHT SWITCH

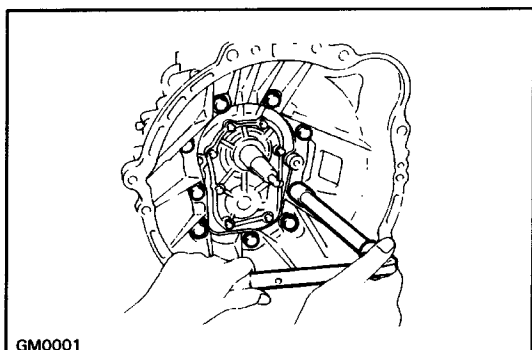

### 3. REMOVE CLUTCH HOUSING FROM TRANSMISSION CASE

Remove the nine bolts and clutch housing.

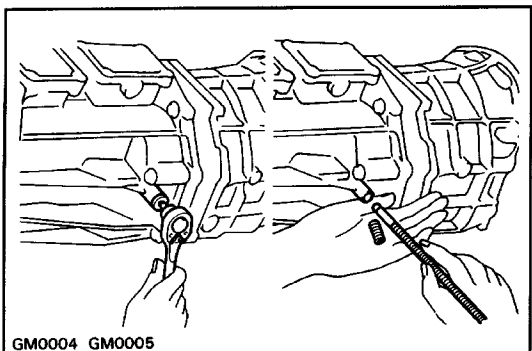

### 4. REMOVE STRAIGHT SCREW PLUG, SPRING AND BALL

- (a) Using a torx socket wrench, remove the screw plug from the transfer adaptor.  
(Torx socket wrench T40 09042–00020)
- (b) Using a magnetic finger, remove the spring and ball.

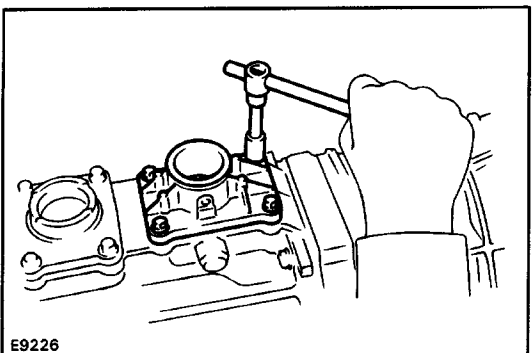

### 5. REMOVE SHIFT LEVER CONTROL RETAINER

- (a) Remove the four bolts and transmission shift lever control retainer.
- (b) Remove the four bolts, transfer shift lever control retainer and select return spring.

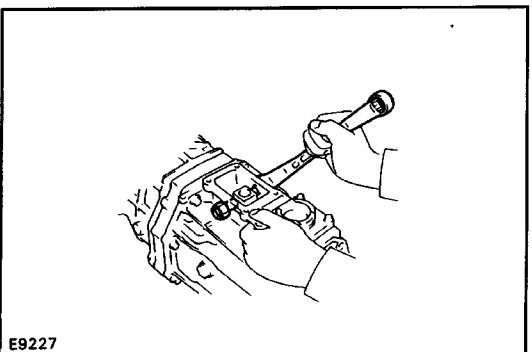

### 6. REMOVE RESTRICT PINS

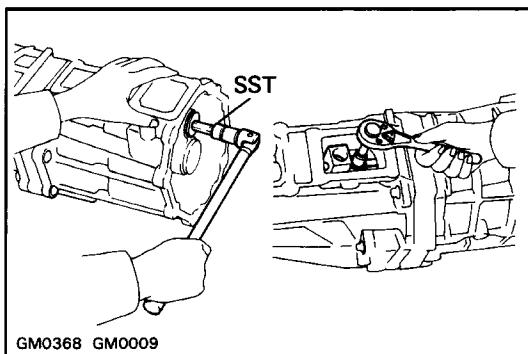

## 7. REMOVE TRANSFER ADAPTOR

- (a) Using SST, remove the plug from the transfer adaptor.  
SST 09923-00010
- (b) Remove the shift lever housing set bolt.

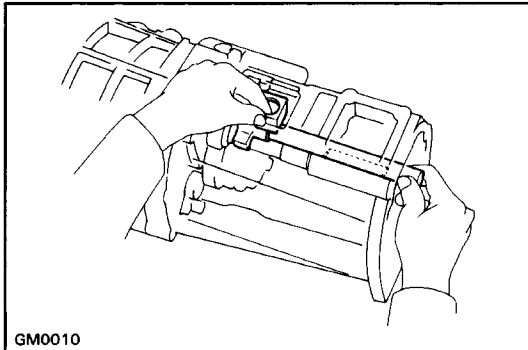

- (c) Remove the shift lever shaft and housing.

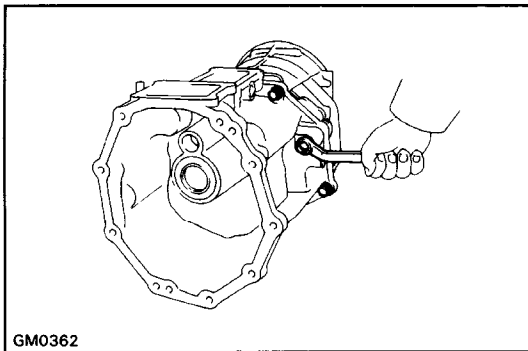

- (d) Remove the eight bolts.
- (e) Using a plastic hammer, carefully tap off the transfer adaptor.

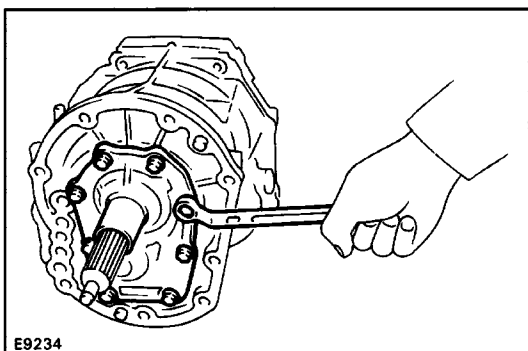

## 8. REMOVE FRONT BEARING RETAINER

Remove the eight bolts, and remove front bearing retainer and gasket.

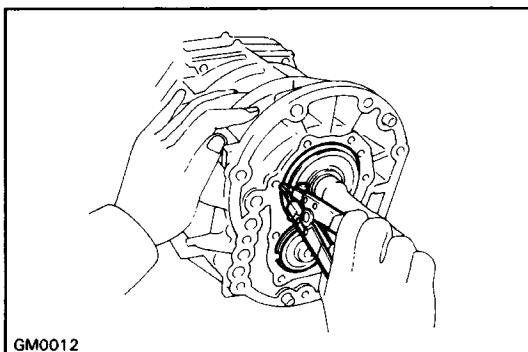

## 9. REMOVE TWO BEARING SNAP RINGS

Using a snap ring expander, remove the two snap rings.

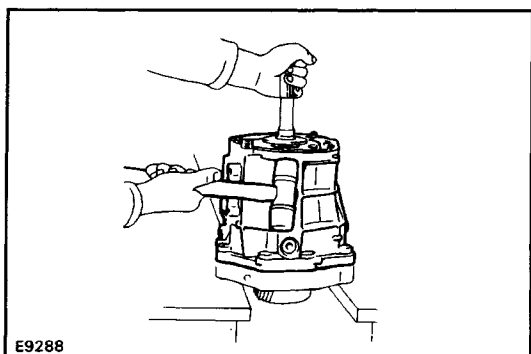

## 10. SEPARATE INTERMEDIATE PLATE FROM TRANSMISSION CASE

- (a) Stand the transmission as shown.
- (b) Using a plastic hammer, carefully tap off the transmission case.

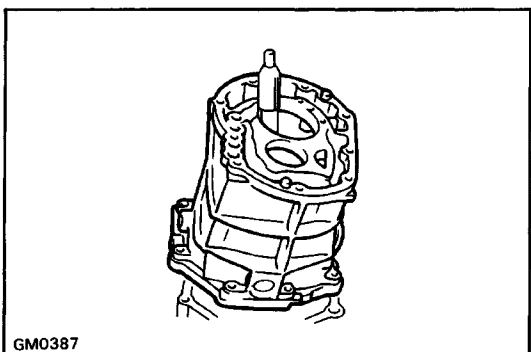

- (c) Remove the transmission case from the intermediate plate as shown.

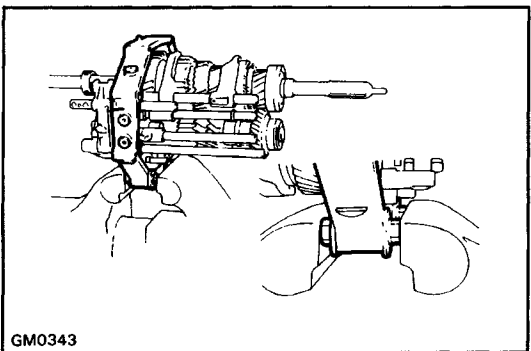

## 11. MOUNT INTERMEDIATE PLATE IN VISE

- (a) Use two clutch housing bolts, plate washers and suitable nuts as shown.

**NOTICE:** Install the plate washers in reverse of normal. Increase or decrease plate washers so that the bolt tip and front tip surface of the nut are aligned.

- (b) Mount the intermediate plate in a vise.

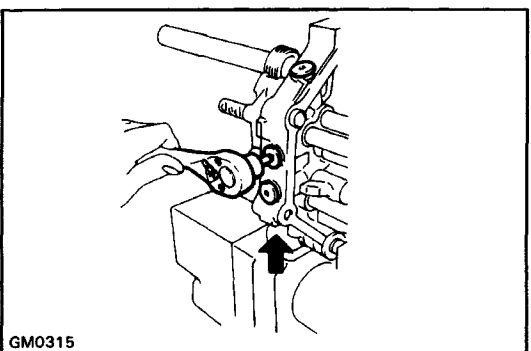

## 12. REMOVE STRAIGHT SCREW PLUGS, LOCKING BALLS AND SPRINGS

- (a) Using a torx socket wrench, remove the four plugs. (Torx socket wrench T40 09042-00020)

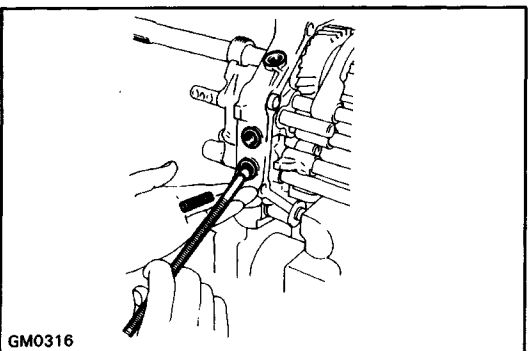

- (b) Using a magnetic finger, remove the springs and balls.

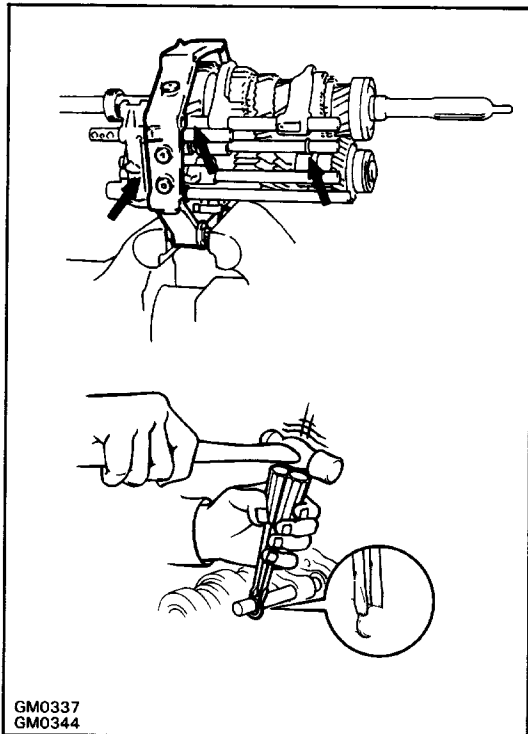
**13. REMOVE SHIFT FORK SHAFT SNAP RINGS**

Using two screwdrivers and a hammer drive out the three snap rings.

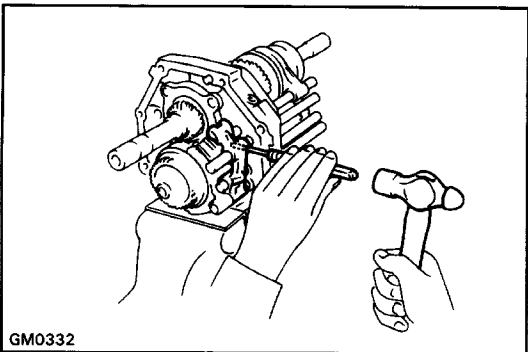
**14. REMOVE SHIFT FORK SHAFT NO.5**

- (a) Using a pin punch and hammer, drive out the slotted spring pin.
- (b) Remove the shift fork shaft No.5.

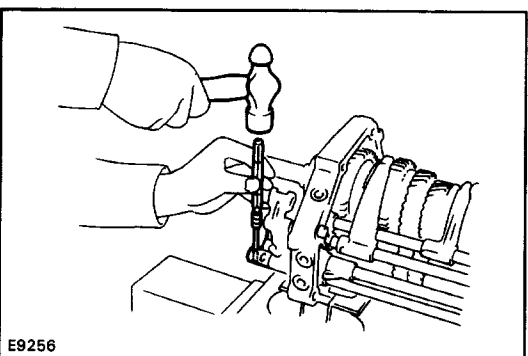
**15. REMOVE SHIFT FORK NO.3, SHIFT FORK SHAFT NO.4 AND REVERSE SHIFT HEAD**

- (a) Using a pin punch and hammer, drive out the slotted spring pin.

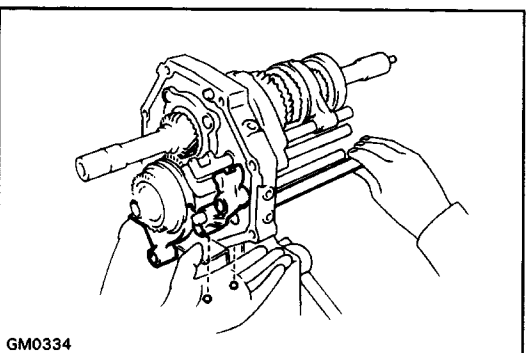

- (b) Remove the shift fork No.3, shift fork shaft No.4, reverse shift head and two balls.

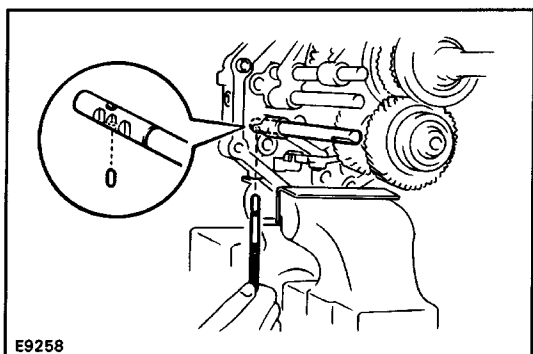

E9258

## 16. REMOVE REVERSE SHIFT ARM, REVERSE SHIFT FORK AND SHIFT FORK SHAFT NO-3

(a) Using a magnetic finger-, remove the interlock pin from shift fork shaft No.3.

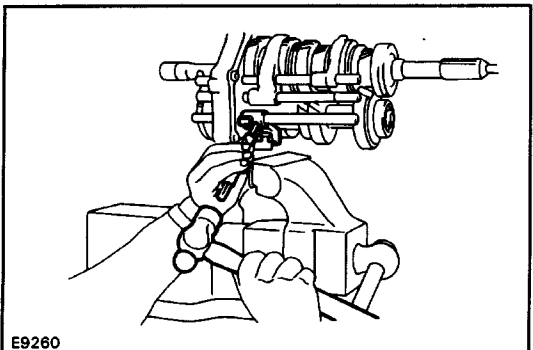

E9260

(b) Using a pin punch and hammer, drive out the slotted spring pin.

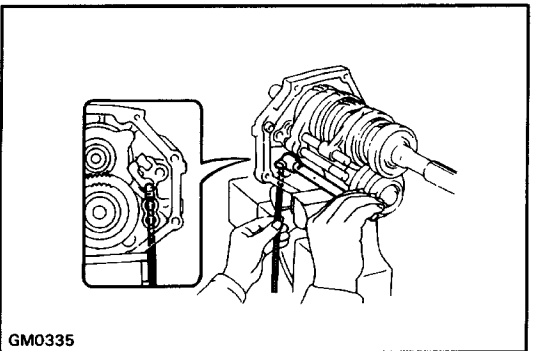

GM0335

(c) Remove the shift fork shaft No.3.

(d) Remove the interlock pin No. 1.

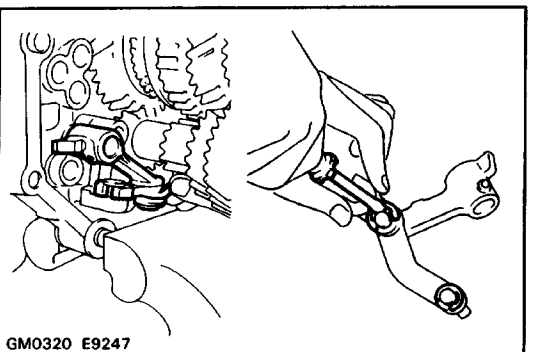

GM0320 E9247

(e) Remove the reverse shift arm and fork.

(f) Using a screwdriver, remove the two E-rings.

(g) Separate the shift arm, fork and shoe.

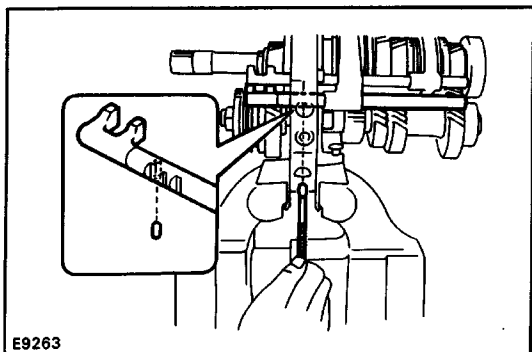

E9263

## 17. REMOVE SHIFT FORK SHAFT NO.1, NO.2 AND SHIFT FORK NO. 1, NO.2

(a) Using a magnetic finger, remove the interlock pin No.2 from shift fork shaft No.2.



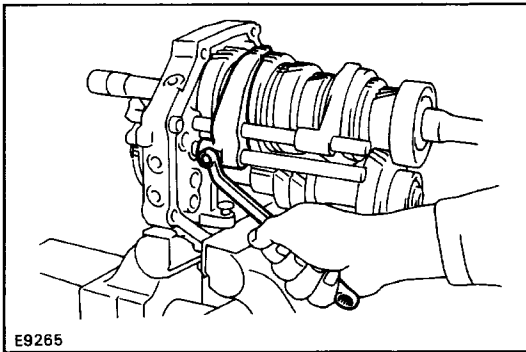

(b) Remove the shift fork No. 1 set bolt.

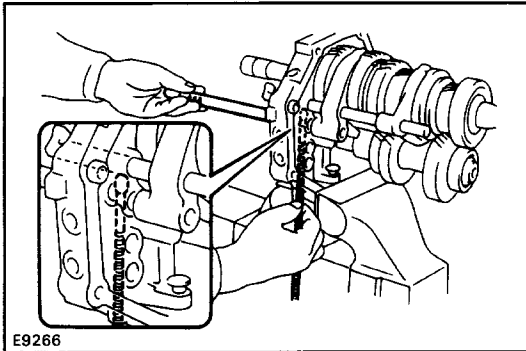

(c) Remove the shift fork shaft No. 1.

(d) Remove the interlock pin No. 1.

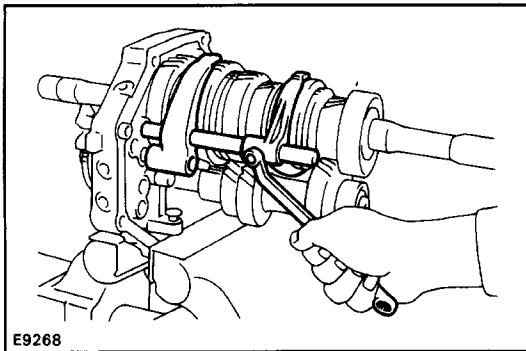

(e) Remove the shift fork No. 2 set bolt.

(f) Remove the shift fork No.1, No.2 and shift fork shaft No.2.

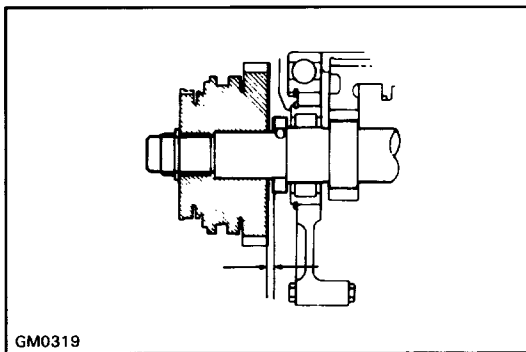

### 18. INSPECT COUNTER FIFTH GEAR THRUST CLEARANCE

Using a feeler gauge, measure the counter 5th gear thrust clearance.

**Standard clearance:** 0.10 – 0.30 mm  
(0.0039 – 0.0118 in.)

**Maximum clearance:** 0.30 mm (0.0118 in.)

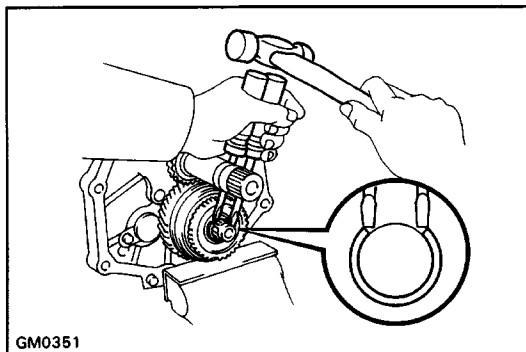

### 19. REMOVE GEAR SPLINE PIECE NO.5, SYNCHRONIZER RING, NEEDLE ROLLER BEARINGS AND COUNTER FIFTH GEAR WITH HUB SLEEVE NO.3

(a) Using two screwdrivers and a hammer, tap out the snap ring.

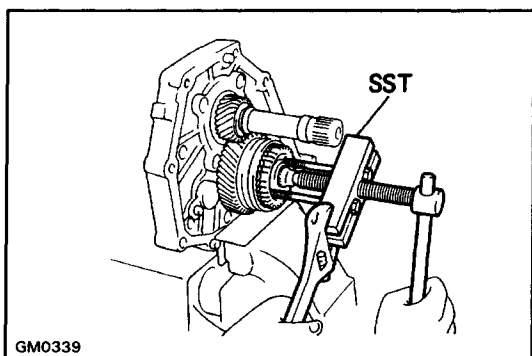

(b) Using SST, remove the gear spline piece No. 5. SST 09213-60017 (09213-00020, 09213-00030, 09213-00060)

(c) Remove the synchronizer ring, needle roller bearing and counter 5th gear.

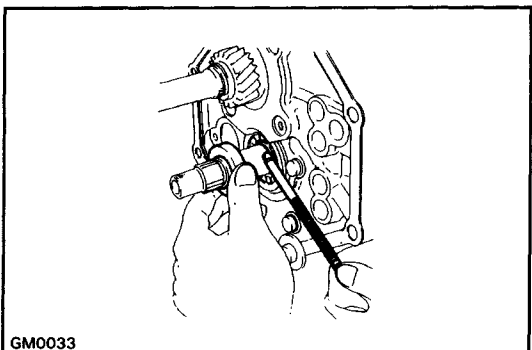

## 20. REMOVE SPACER AND BALL

(a) Remove the spacer.

(b) Using a magnetic finger, remove the ball.

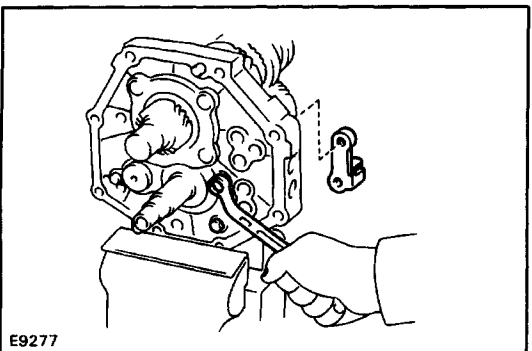

## 21. REMOVE REVERSE SHIFT ARM BRACKET

Remove the two bolts and reverse shift arm bracket.

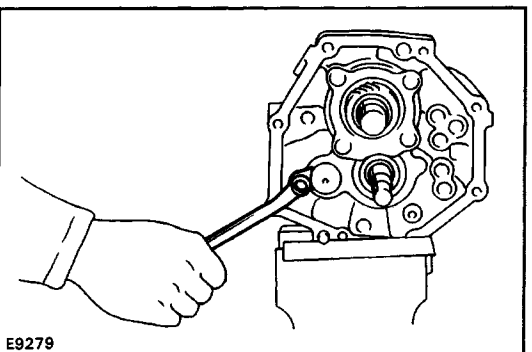

## 22. REMOVE REVERSE IDLER GEAR AND SHAFT

(a) Remove the reverse idler gear shaft stopper set bolt and stopper.

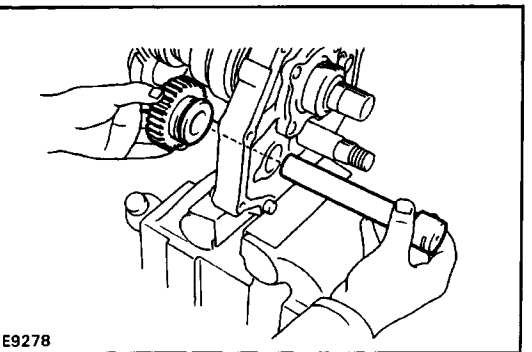

(b) Remove the reverse idler gear and shaft.

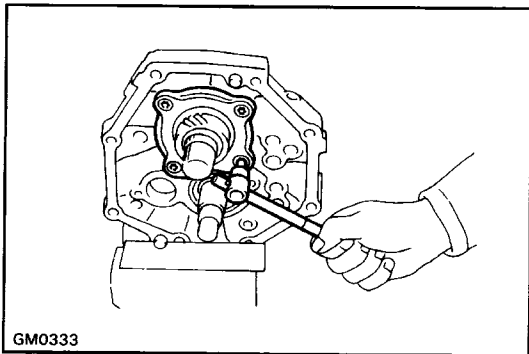
**23. REMOVE REAR BEARING RETAINER**

Using a torx socket wrench, remove the four bolts.  
(Torx socket wrench T40 09042-00020)

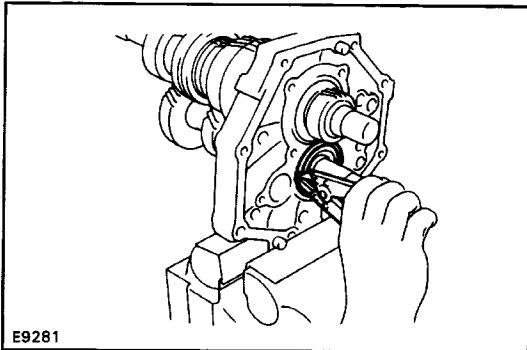
**24. REMOVE COUNTER GEAR**

(a) Using a snap ring expander, remove the counter gear rear bearing snap ring.

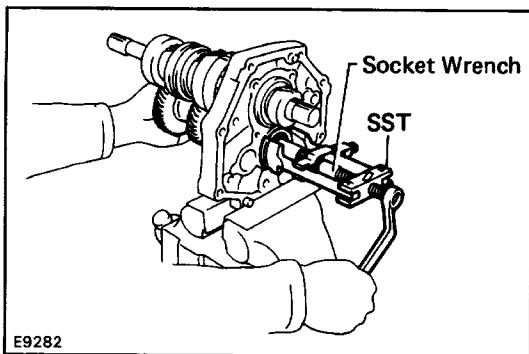

(b) Using SST and 12 mm socket wrench, remove the counter gear rear bearing.  
SST 09602-35011

(c) Remove the counter gear.

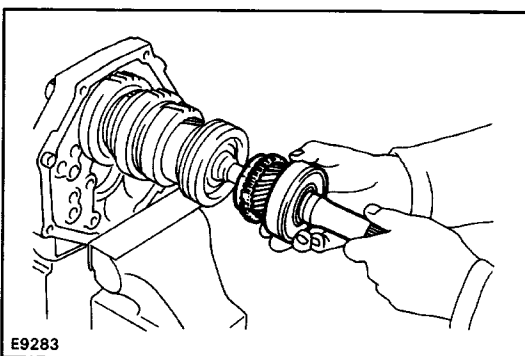
**25. REMOVE INPUT SHAFT**

Remove the input shaft with 13 needle roller bearings and synchronizer ring from output shaft.

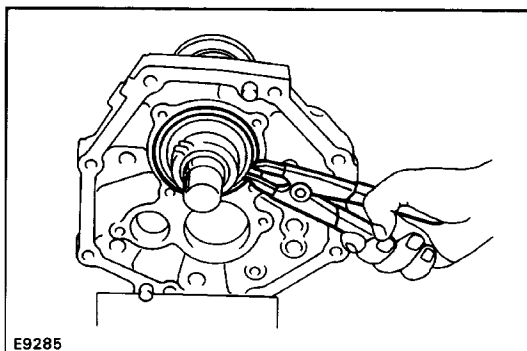
**26. REMOVE OUTPUT SHAFT**

(a) Using a snap ring expander, remove the output shaft center bearing snap ring.

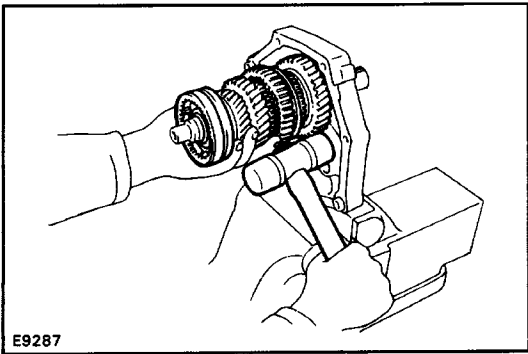

(b) Remove the output shaft, from the intermediate plate by pulling on the output shaft and tapping on the intermediate plate with plastic hammer.

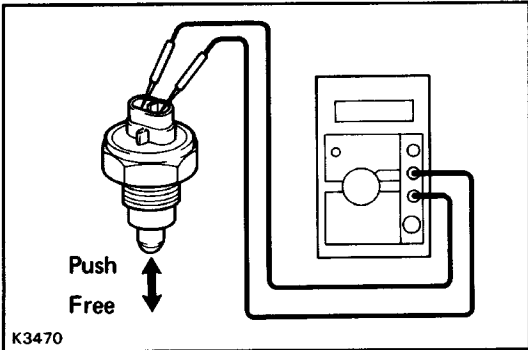

**27. INSPECT BACK-UP LIGHT SWITCH**

Check that there is continuity between terminals as shown.

Switch Position	Specified
Push	Continuity
Free	No continuity

If operation is not as specified, replace switch.

## COMPONENT PARTS

### Input Shaft Assembly

#### COMPONENTS

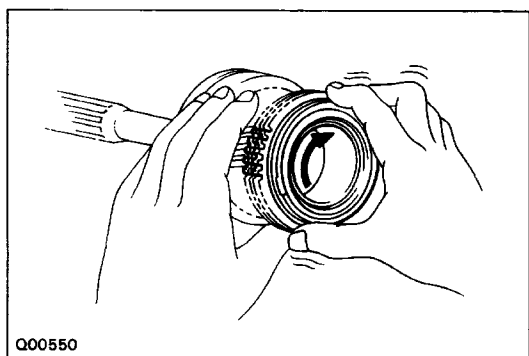
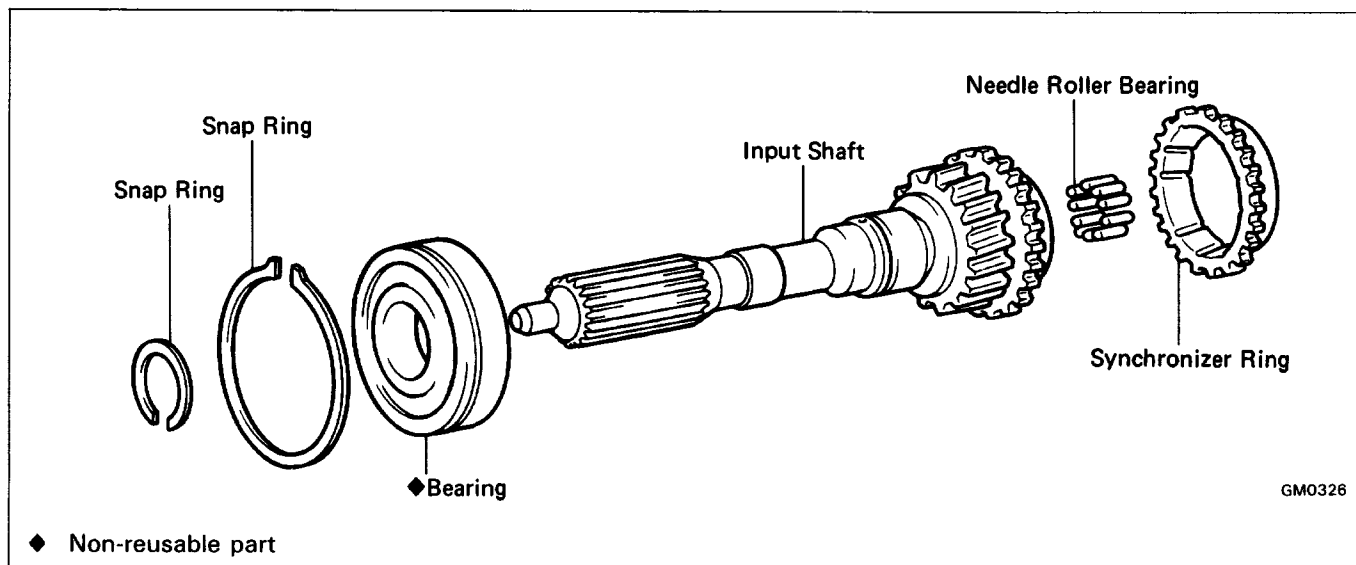

#### INSPECTION OF INPUT SHAFT ASSEMBLY

#### INSPECT SYNCHRONIZER RING

(a) Turn the ring and push it into check braking action.

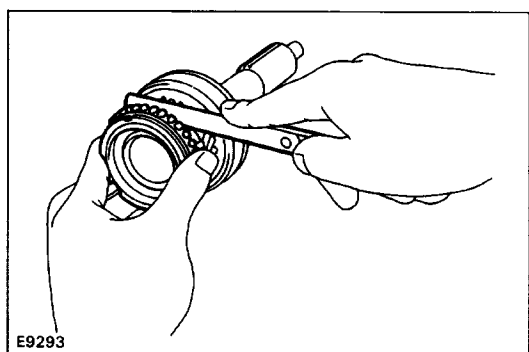

(b) Using a feeler gauge, measure the clearance between the synchronizer ring back and gear spline end.

**Standard clearance:** 1.0 – 2.0 mm  
(0.040 – 0.079 in.)

**Minimum clearance:** 0.8 mm (0.031 in.)

If the clearance is less than the minimum, replace the synchronizer ring.

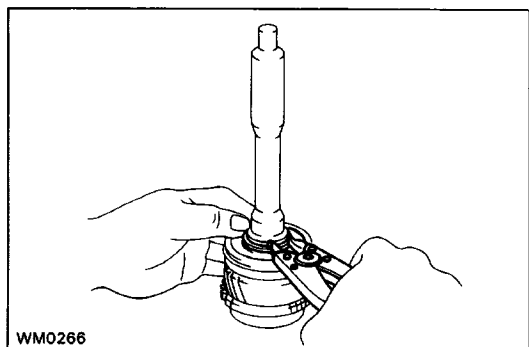

#### REPLACEMENT OF BEARING

#### IF NECESSARY, REPLACE INPUT SHAFT BEARING

(a) Using a snap ring expander, remove the snap ring.

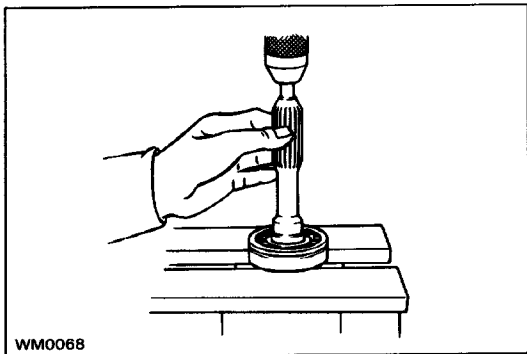

(b) Using a press, remove the bearing.

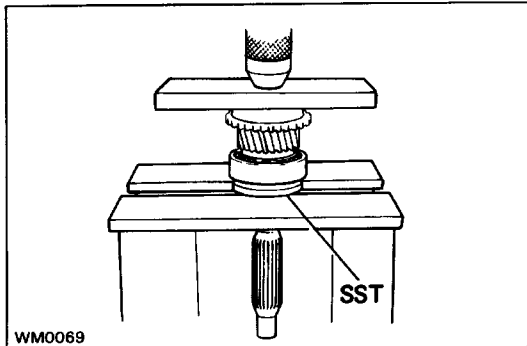

(c) Using SST and a press, install a new bearing.  
SST 09506-35010

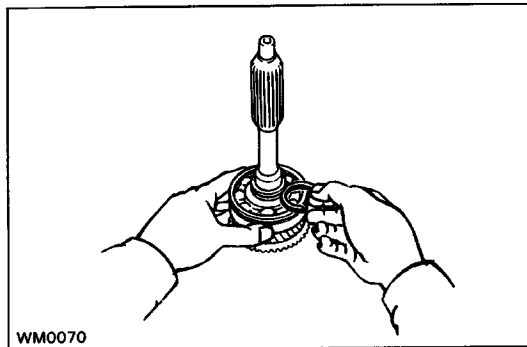

(d) Select a snap ring that will allow minimum axial play.

Mark	Thickness	mm (in.)
0	2.05 – 2.10	(0.0807 – 0.0827)
1	2.10 – 2.15	(0.0827 – 0.0846)
2	2.15 – 2.20	(0.0846 – 0.0866)
3	2.20 – 2.25	(0.0866 – 0.0886)
4	2.25 – 2.30	(0.0886 – 0.0906)
5	2.30 – 2.35	(0.0906 – 0.0925)

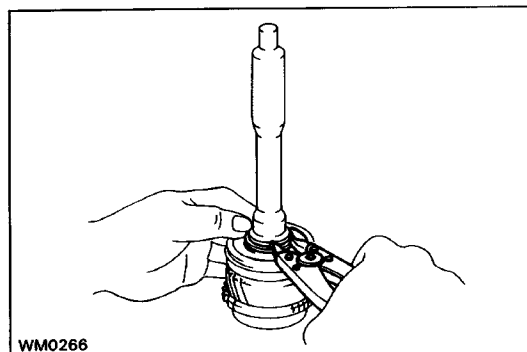

(e) Using a snap ring expander, install the snap ring.

# Output Shaft Assembly COMPONENTS

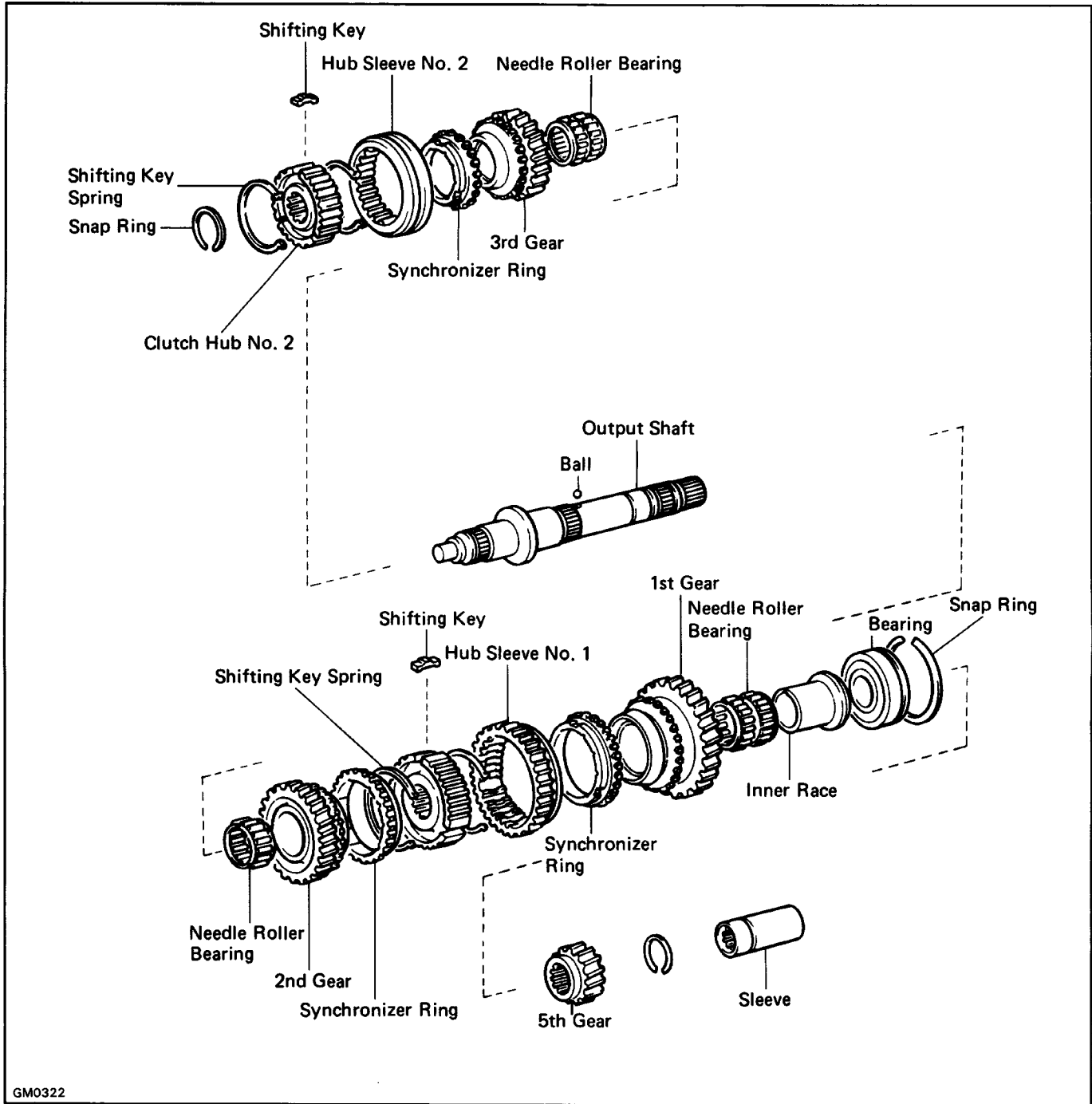

GM0322

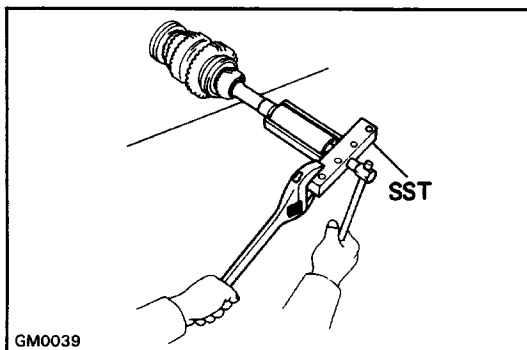

GM0039

## DISASSEMBLY OF OUTPUT SHAFT ASSEMBLY

### 1. REMOVE SLEEVE FROM OUTPUT SHAFT

Using SST, remove the sleeve from the output shaft.

SST 09950-20017

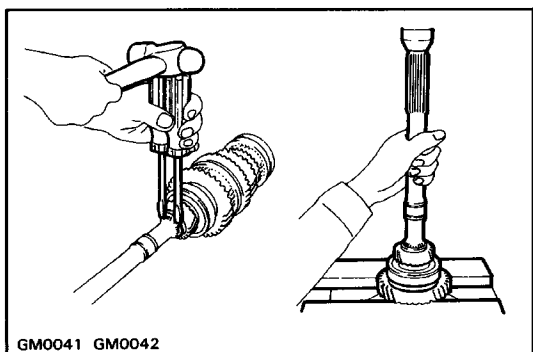

## 2. REMOVE FIFTH GEAR, REAR BEARING, FIRST GEAR, INNER RACE AND NEEDLE ROLLER BEARING

- (a) Using two screwdrivers and a hammer, tap out the snap ring.
- (b) Using a press, remove the 5th gear, rear bearing, 1st gear and inner race.
- (c) Remove the needle roller bearing.

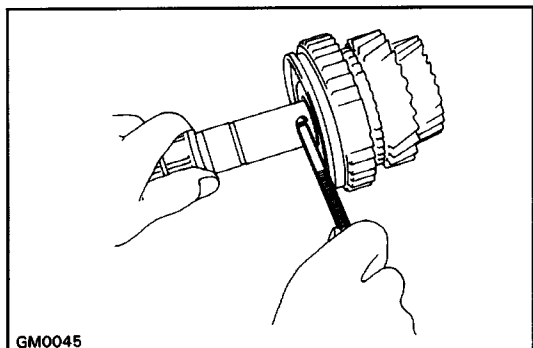

## 3. REMOVE SYNCHRONIZER RING

## 4. REMOVE LOCKING BALL

Using a magnetic finger, remove the locking ball.

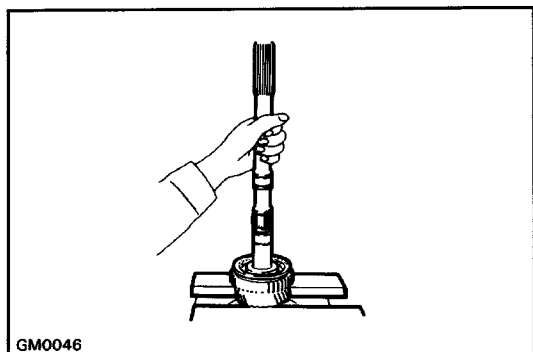

## 5. REMOVE HUB SLEEVE NO. 1 ASSEMBLY, SYNCHRONIZER RING, SECOND GEAR AND NEEDLE ROLLER BEARING

- (a) Using a press, remove hub sleeve No.1, the synchronizer ring and 2nd gear.
- (b) Remove the needle roller bearing.

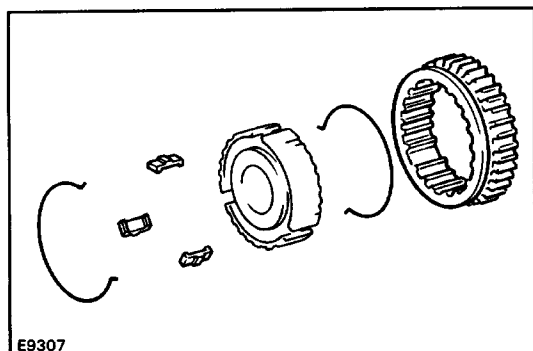

## 6. REMOVE HUB SLEEVE NO. 1, SHIFTING KEYS AND SPRINGS FROM CLUTCH HUB NO. 1

Using a screwdriver, remove the three shifting keys and two springs from clutch hub No. 1.

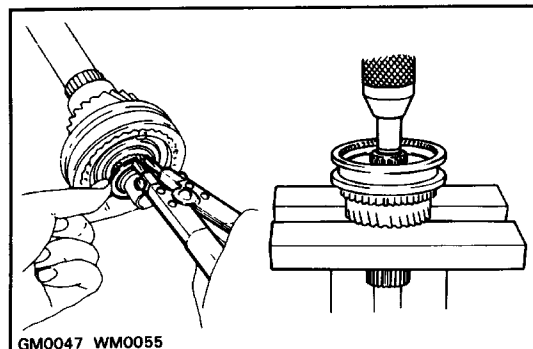

## 7. REMOVE HUB SLEEVE NO.2 ASSEMBLY, SYNCHRONIZER RING, THIRD GEAR AND NEEDLE ROLLER BEARING

- (a) Using a snap ring expander, remove the snap ring.
- (b) Using a press, remove the hub sleeve No.2, the synchronizer ring and 3rd gear.
- (c) Remove the needle roller bearing.



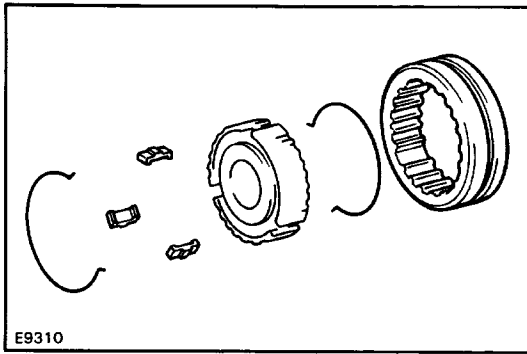

### 8. REMOVE HUB SLEEVE NO.2, SHIFTING KEYS AND SPRINGS FROM CLUTCH HUB NO.2

Using a screwdriver, remove the three shifting keys and springs from clutch hub No.2.

## INSPECTION OF OUTPUT SHAFT ASSEMBLY

### 1. INSPECT EACH GEAR THRUST CLEARANCE

Using a feeler gauge, measure the thrust clearance of each gear.

**Standard clearance: 0.10 – 0.25 mm**  
(0.0039 – 0.0098 in.)

**Maximum clearance: 0.25 mm (0.0098 in.)**

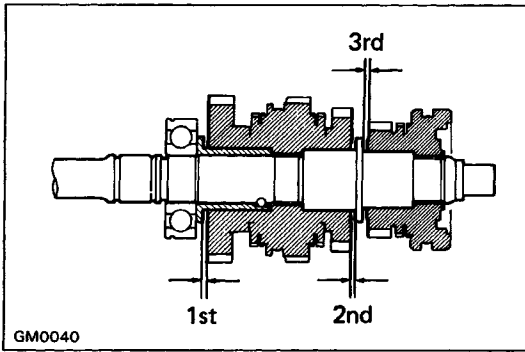

GM0040

### 2. INSPECT EACH GEAR OIL CLEARANCE

Using a dial indicator, measure the each gear oil clearance.

**Standard clearance: 0.009 – 0.032 mm**  
(0.0004 – 0.0013 in.)

**Maximum clearance: 0.032 mm (0.0013 in.)**

If the clearance exceeds the maximum, replace the gear, needle roller bearing or shaft.

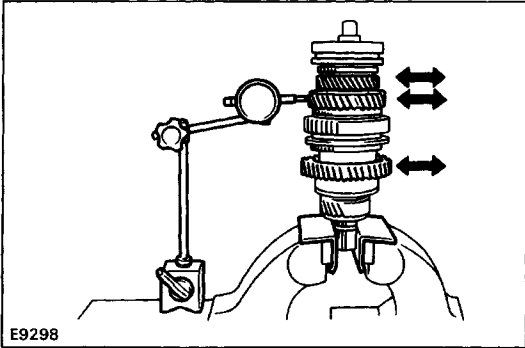

E9298

### 3. INSPECT OUTPUT SHAFT AND INNER RACE

(a) Using calipers, measure the output shaft flange thickness.

**Minimum thickness: 4.80 mm (0.1890 in.)**

If the thickness exceeds the minimum, replace the output shaft.

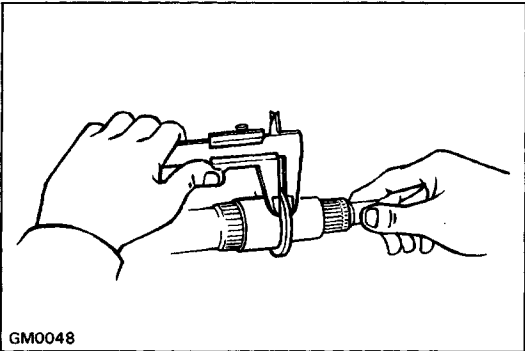

GM0048

(b) Using calipers, measure the inner race flange thickness.

**Minimum thickness: 3.99 mm (0.1571 in.)**

If the thickness exceeds the minimum, replace the inner race.

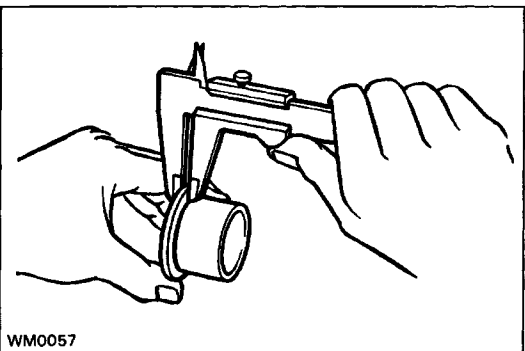

WM0057

(c) Using a micrometer, measure the outer diameter of the output shaft journal.

**Minimum diameter:**

**2nd gear 37.984 mm (1.4954 in.)**

**3rd gear 34.984 mm (1.3773 in.)**

If the outer diameter exceeds the minimum, replace the output shaft.

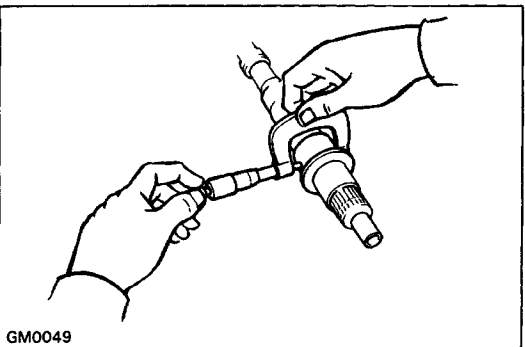

GM0049

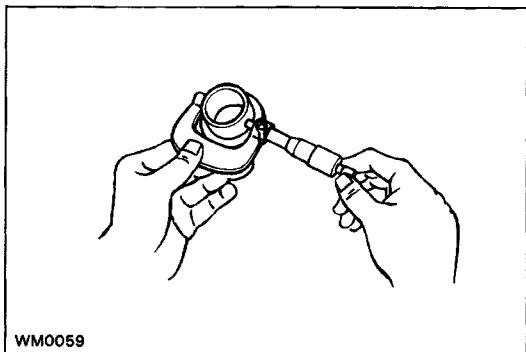

(d) Using a micrometer, measure the outer diameter of the inner race.

**Minimum diameter: 38.985 mm (1.5348 in.)**

If the outer diameter exceeds the minimum, replace the inner race.

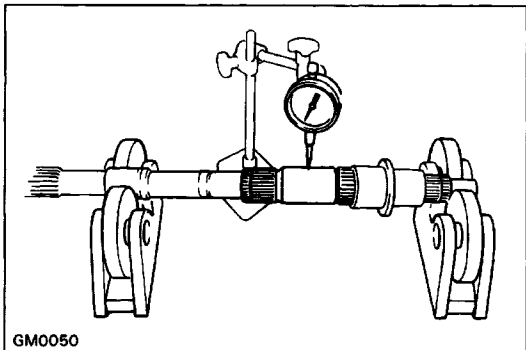

(e) Using a dial indicator, check the shaft runout.

**Maximum runout: 0.05 mm (0.0020 in.)**

If the runout exceeds the maximum, replace the output shaft.

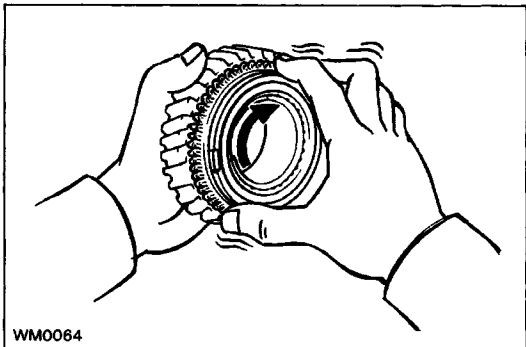

#### 4. INSPECT SYNCHRONIZER RINGS

(a) Check for wear or damage.

(b) Turn the ring and push it in to check the braking action.

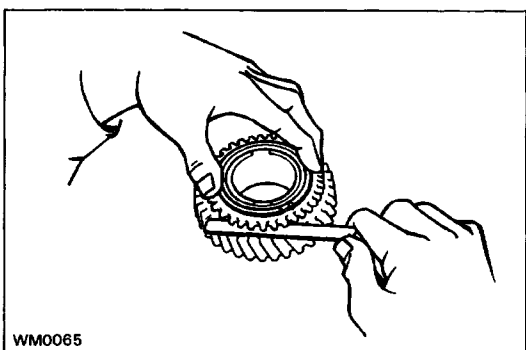

(c) Using a feeler gauge, measure the clearance between the synchronizer ring back and gear spline end.

**Standard clearance: 1.0 – 2.0 mm**

**(0.039 – 0.079 in.)**

**Minimum clearance: 0.8 mm (0.031 in.)**

If the clearance exceeds the minimum, replace the synchronizer ring.

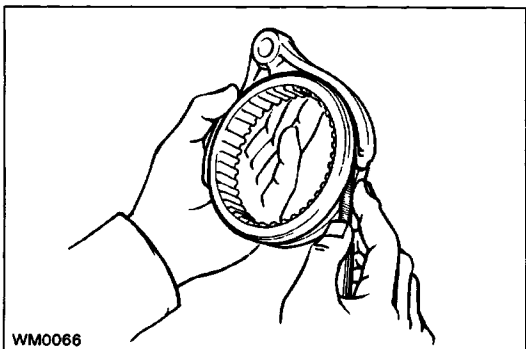

#### 5. INSPECT CLEARANCE OF SHIFT FORKS AND HUB SLEEVES

Using a feeler gauge, measure the clearance between the hub sleeve and shift fork.

**Maximum clearance: 1.0 mm (0.039 in.)**

If the clearance exceeds the maximum, replace the shift fork or hub sleeve.

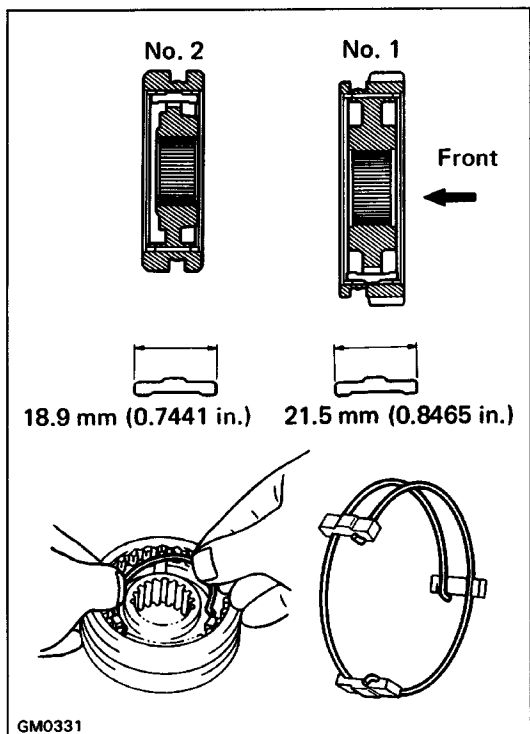

**ASSEMBLY OF OUTPUT SHAFT ASSEMBLY**  
**1. INSTALL CLUTCH HUB NO.1 AND NO.2 INTO HUB SLEEVE**

HINT: Coat all of the sliding and rotating surface with gear oil before assembly.

- (a) Install the clutch hub and shifting keys to the hub sleeve.
- (b) Install the shifting key springs under the shifting keys.

**NOTICE: Install the key springs positioned so that their end gaps are not in line.**

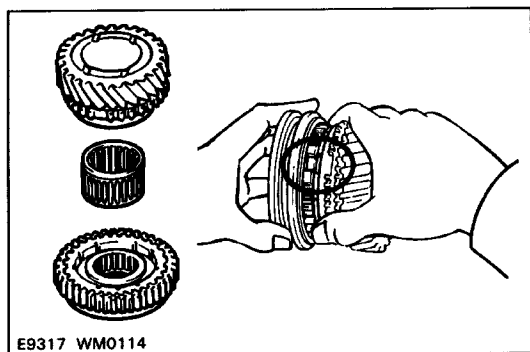

**2. INSTALL THIRD GEAR AND HUB SLEEVE NO.2 ON OUTPUT SHAFT**

- (a) Apply gear oil to the shaft and needle roller bearing.
- (b) Place the synchronizer ring on the gear and align the ring slots with the shifting keys.
- (c) Install the needle roller bearing in the 3rd gear.

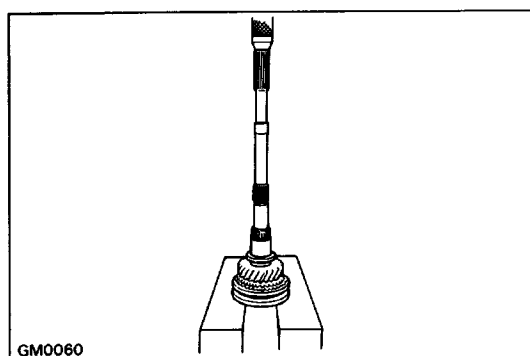

- (d) Using a press, install the 3rd gear and hub sleeve No. 2.

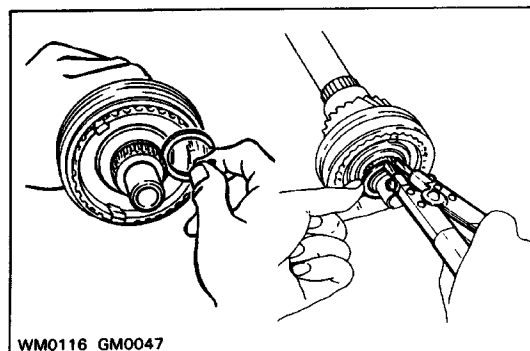

**3. INSTALL SNAP RING**

Select a snap ring that will allow minimum axial play and install it on the shaft.

Mark	Thickness mm (in.)
C-1	1.75 - 1.80 (0.0689 - 0.0709)
D	1.80 - 1.85 (0.0709 - 0.0728)
D-1	1.85 - 1.90 (0.0728 - 0.0748)
E	1.90 - 1.95 (0.0748 - 0.0768)
E-1	1.95 - 2.00 (0.0768 - 0.0787)
F	2.00 - 2.05 (0.0787 - 0.0807)
F-1	2.05 - 2.10 (0.0807 - 0.0827)

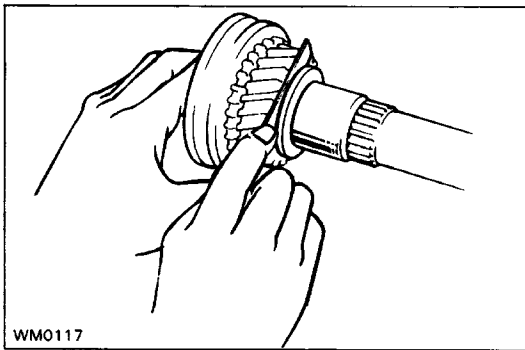

WM0117

#### 4. INSPECT THIRD GEAR THRUST CLEARANCE

Using a feeler gauge, measure the 3rd gear thrust clearance.

**Standard clearance: 0.10 – 0.25 mm  
(0.0039 – 0.0098 in.)**

**Maximum clearance: 0.25 mm (0.0098 in.)**

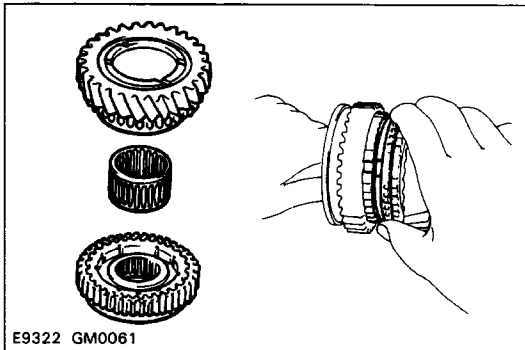

E9322 GM0061

#### 5. INSTALL SECOND GEAR AND HUB SLEEVE NO. 1

- (a) Apply gear oil to the shaft and needle roller bearing.
- (b) Place the synchronizer ring on the gear and align the ring slots with the shifting keys.
- (c) Install the needle roller bearing in the 2nd gear.

- (d) Using a press, install the 2nd gear and hub sleeve No. 1.

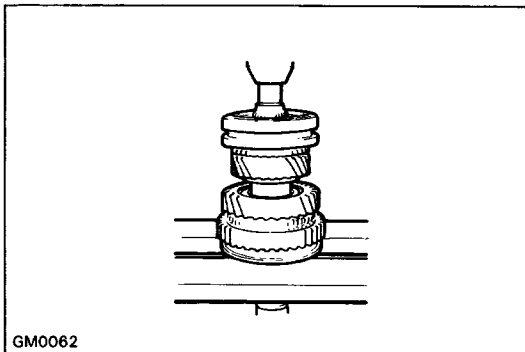

GM0062

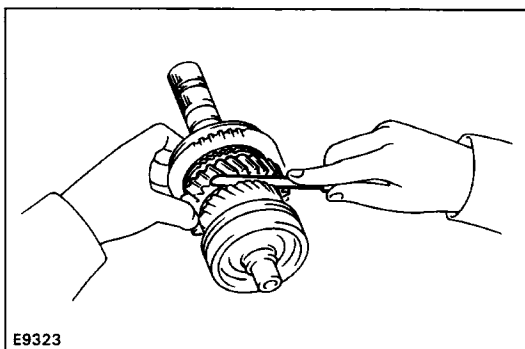

E9323

#### 6. INSPECT SECOND GEAR THRUST CLEARANCE

Using a feeler gauge, measure the 2nd gear thrust clearance.

**Standard clearance: 0.10 – 0.25 mm  
(0.0039 – 0.0098 in.)**

**Maximum clearance: 0.25 mm (0.0098 in.)**

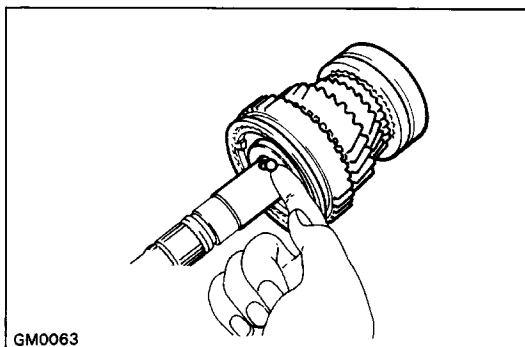

GM0063

#### 7. INSTALL LOCKING BALL AND FIRST GEAR ASSEMBLY

- (a) Install the locking ball in the shaft.

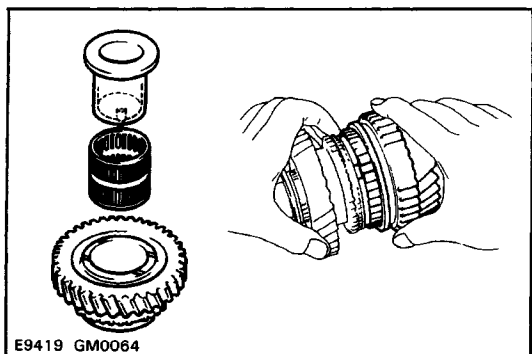

- (b) Apply gear oil to the needle roller bearing.
- (c) Assemble the 1st gear, synchronizer ring, needle roller bearing and bearing inner race.
- (d) Install the assembly on the output shaft with the synchronizer ring slots aligned with shifting keys.
- (e) Turn the inner race to align it with the locking ball.

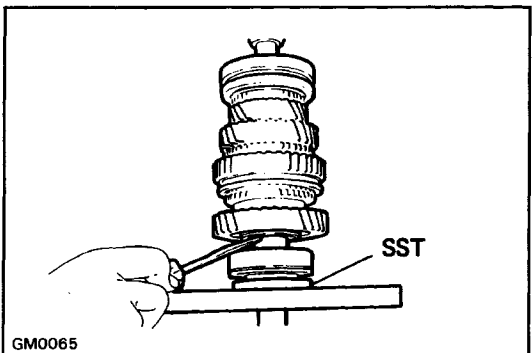

**8. INSTALL OUTPUT SHAFT REAR BEARING**

Using SST and a press, install the bearing on the output shaft with outer race snap ring groove toward the rear.

HINT: Hold the 1st gear inner race to prevent it from falling.

SST 09 506-3 5010

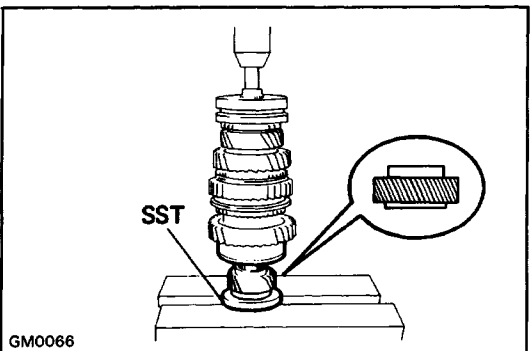

**9. INSTALL FIFTH GEAR**

Using SST and a press, install the 5th gear.

SST 09506-35010

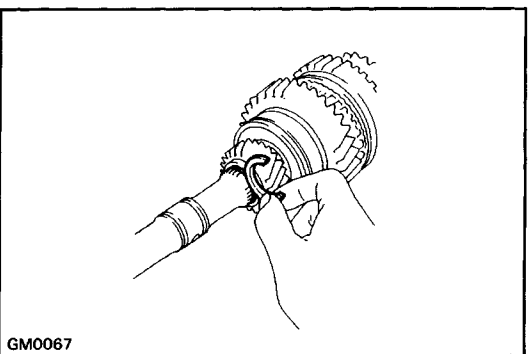

**10. INSTALL SNAP RING**

- (a) Select a snap ring that will allow minimum axial play.

Mark	Thickness mm (in.)
A	2.67 – 2.72 (0.1051 – 0.1071)
B	2.73 – 2.78 (0.1075 – 0.1094)
C	2.79 – 2.84 (0.1098 – 0.1118)
D	2.85 – 2.90 (0.1122 – 0.1142)
E	2.91 – 2.96 (0.1146 – 0.1165)
F	2.97 – 3.02 (0.1169 – 0.1189)
G	3.03 – 3.08 (0.1193 – 0.1213)
H	3.09 – 3.14 (0.1217 – 0.1236)
J	3.15 – 3.20 (0.1240 – 0.1260)
K	3.21 – 3.26 (0.1264 – 0.1283)
L	3.27 – 3.32 (0.1287 – 0.1307)

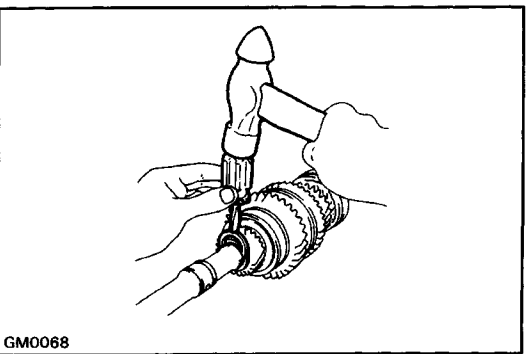

- (b) Using a screwdriver and hammer, tap in the snap ring.

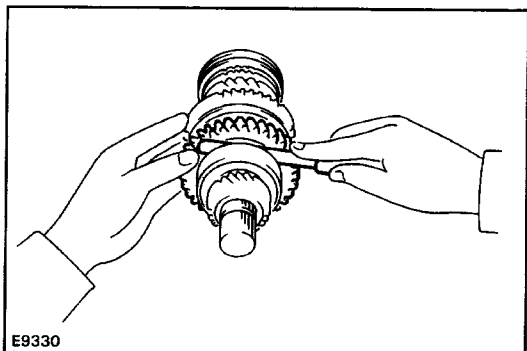

### 11. MEASURE FIRST GEAR THRUST CLEARANCE

Using a feeler gauge, measure the 1 st gear thrust clearance.

**Standard clearance: 0.10 – 0.25 mm**

**(0.0039 – 0.0098 in.)**

**Maximum clearance: 0.25 mm (0.0098 in.)**

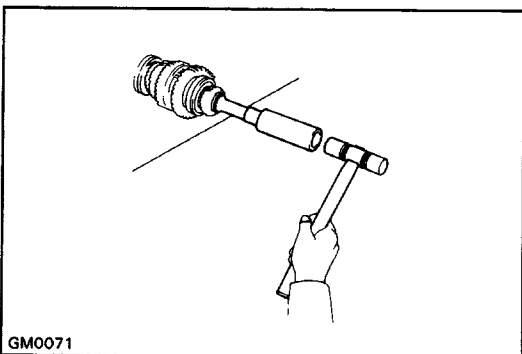

### 12. INSTALL SLEEVE TO OUTPUT SHAFT

Using a plastic hammer, tap the sleeve onto the output shaft.

# Counter Gear Assembly and Reverse Idler Gear COMPONENT

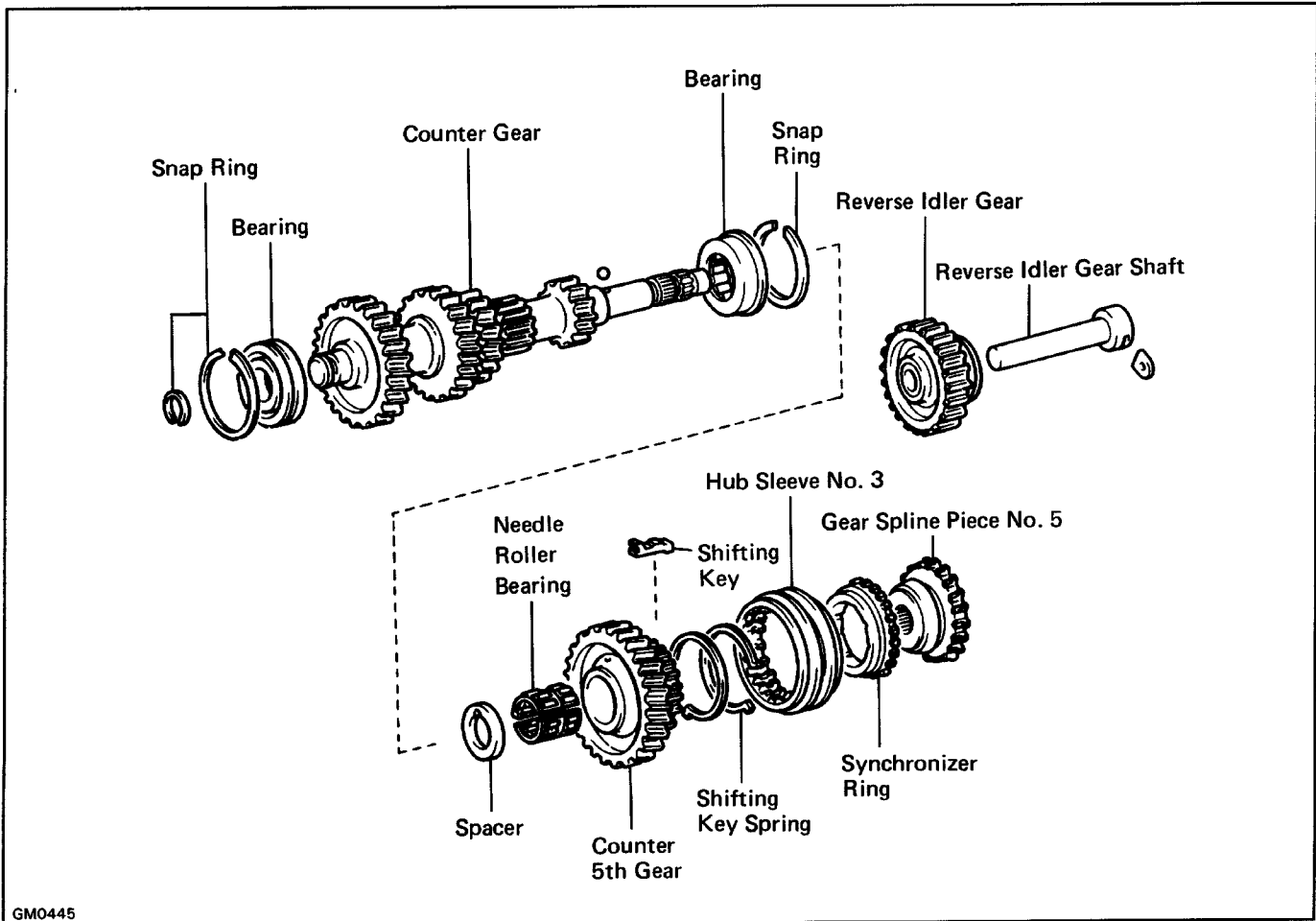

GM0445

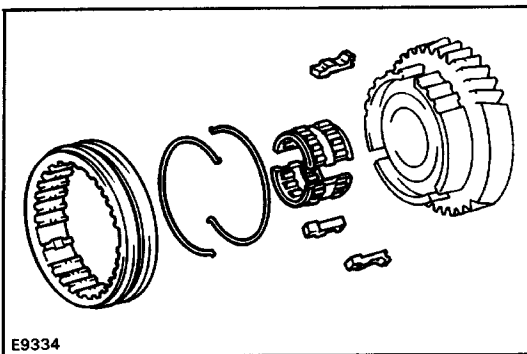

E9334

## DISASSEMBLY OF COUNTER GEAR ASSEMBLY REMOVE HUB SLEEVE NO.3 SHIFTING KEYS AND SPRINGS

Using a screwdriver, remove the hub sleeve No.3, three shifting keys and two springs.

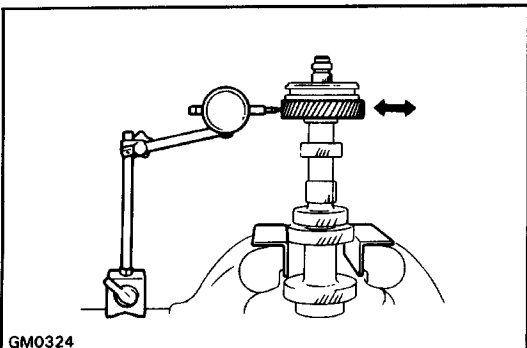

GM0324

## INSPECTION OF COUNTER GEAR ASSEMBLY

### 1. INSPECT COUNTER FIFTH GEAR OIL CLEARANCE

(a) Install the spacer, needle roller bearing and counter 5th gear to counter gear.

(b) Using a dial indicator, measure the counter 5th gear oil clearance.

**Standard clearance: 0.009 – 0.032 mm**

**(0.0004 – 0.0013 in.)**

**Maximum clearance: 0.032 mm 10.0013 in.)**

If the clearance exceeds the maximum, gear, needle roller bearing or counter gear assembly.



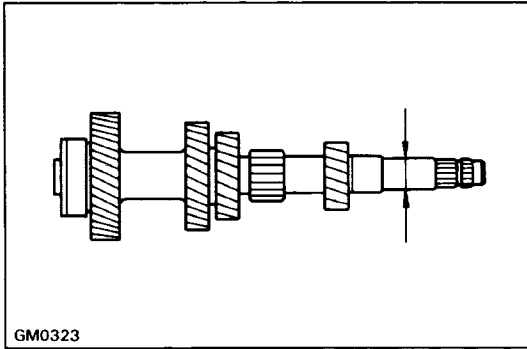

## 2. INSPECT COUNTER GEAR

Using a micrometer, measure the outer diameter of needle roller bearing race.

**Standard clearance: 25.98 – 26.00 mm**  
(1.0228 – 1.0236 in.)

**Maximum clearance: 25.86 mm (1.0181 in.)**

If the outer diameter exceeds the maximum, replace the counter gear.

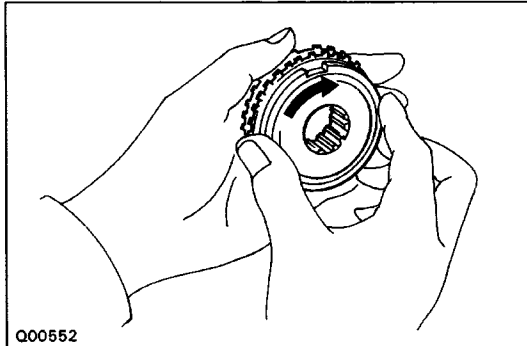

## 3. INSPECT SYNCHRONIZER RING

- (a) Check for wear or damage.
- (b) Turn the ring and push it in to check the braking action.

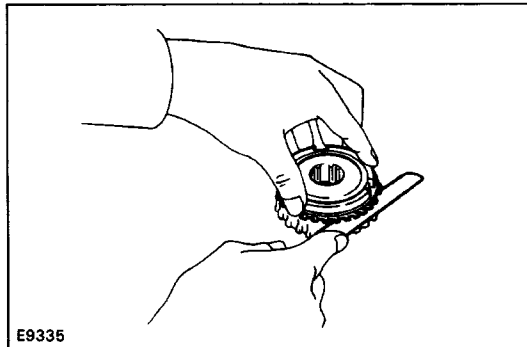

- (c) Measure the clearance between the synchronizer ring back and the spline end.

**Standard clearance: 1.0 – 2.0 mm**  
(0.039 – 0.079 in.)

**Minimum clearance: 0.8 mm (0.031 in.)**

If the clearance is less than the minimum, replace the synchronizer ring.

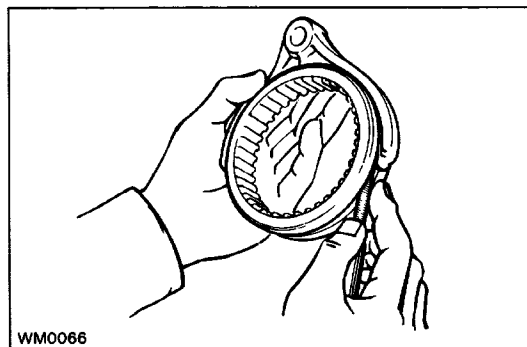

## 4. MEASURE CLEARANCE OF SHIFT FORK AND HUB SLEEVE

Using a feeler gauge, measure the clearance between the hub sleeve and shift fork.

**Maximum clearance: 1.0 mm (0.039 in.)**

If the clearance exceeds the maximum, replace the shift fork or hub sleeve.

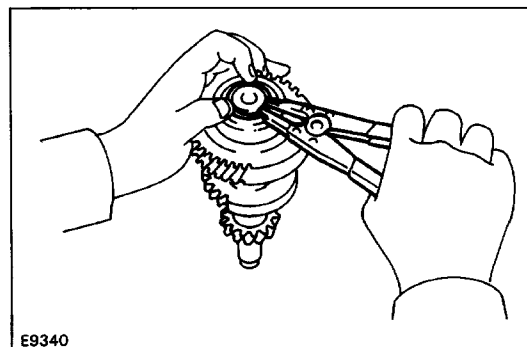

## REPLACEMENT OF BEARING

### IF NECESSARY, REPLACE COUNTER GEAR FRONT BEARING

- (a) Using a snap ring expander, remove the snap ring.

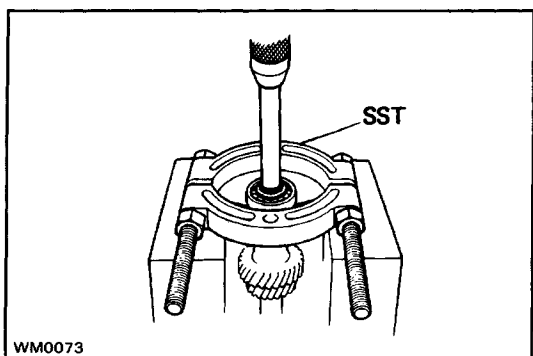

(b) Using SST and a press, remove the bearing.

SST 09950-00020

(c) Replace the side race.

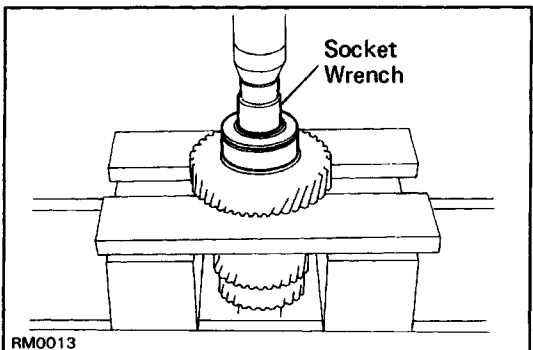

(d) Using a socket wrench and press, install the bearing, side race and inner race.

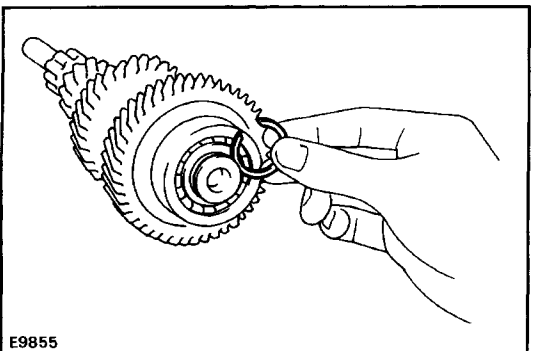

(e) Select a snap ring that will allow minimum axial play.

Mark	Thickness mm (in.)
1	2.05 – 2.10 (0.0807 – 0.0827)
2	2.10 – 2.15 (0.0827 – 0.0846)
3	2.15 – 2.20 (0.0846 – 0.0866)
4	2.20 – 2.25 (0.0866 – 0.0886)
5	2.25 – 2.30 (0.0886 – 0.0906)
6	2.30 – 2.35 (0.0906 – 0.0925)

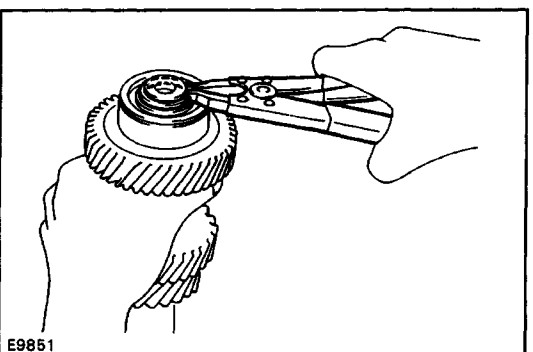

(f) Using a snap ring expander, install the snap ring.

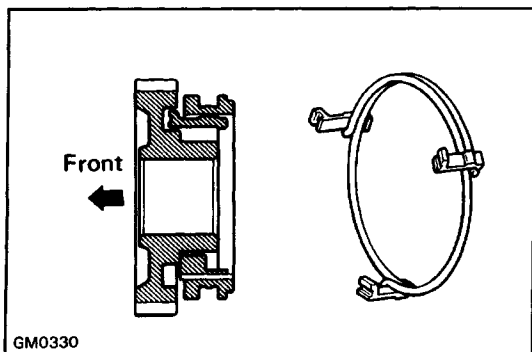

## ASSEMBLY OF COUNTER GEAR ASSEMBLY INSTALL HUB SLEEVE NO.3, SHIFTING KEYS AND SPRINGS

(a) Install the clutch hub and shifting keys to the hub sleeve.

(b) Install the shifting key springs under the shifting keys.

**NOTICE:** Install the key springs positioned so that their end gaps are not in line.

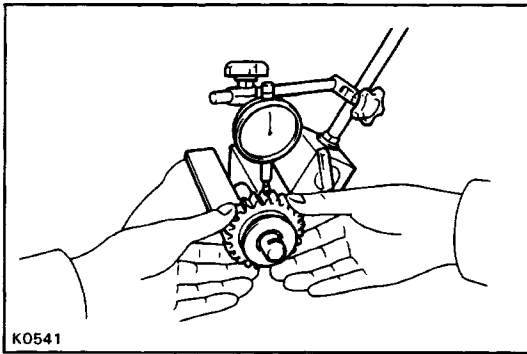

## INSPECTION OF REVERSE IDLER GEAR

### 1. INSPECT REVERSE IDLER GEAR OIL CLEARANCE

Using a dial indicator measure reverse idler gear oil clearance .

**Standard clearance: 0.04 – 0.08 mm**  
**(0.0016 – 0.0031 in.)**

**Maximum clearance: 0.13 mm (0.0051 in.)**

If the clearance exceeds the maximum, replace the gear or shaft.

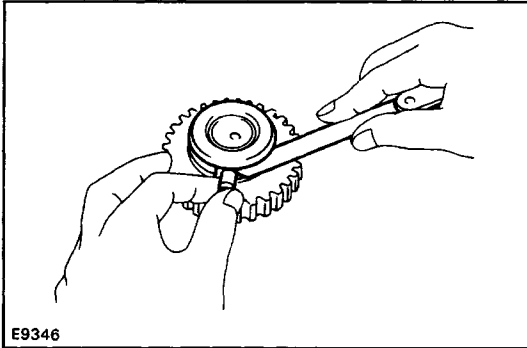

### 2. INSPECT CLEARANCE OF REVERSE IDLER GEAR AND SHIFT ARM SHOE

Using a feeler gauge, measure the clearance between the reverse idler gear and shift arm shoe.

**Standard clearance: 0.05 – 0.27 mm**  
**(0.0020 – 0.106 in.)**

**Maximum clearance: 0.5 mm (0.197 in.)**

If the clearance exceeds the maximum, replace the gear or shift arm shoe.

# Transfer Adaptor COMPONENTS

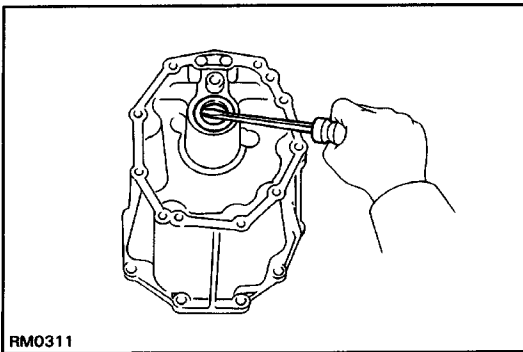
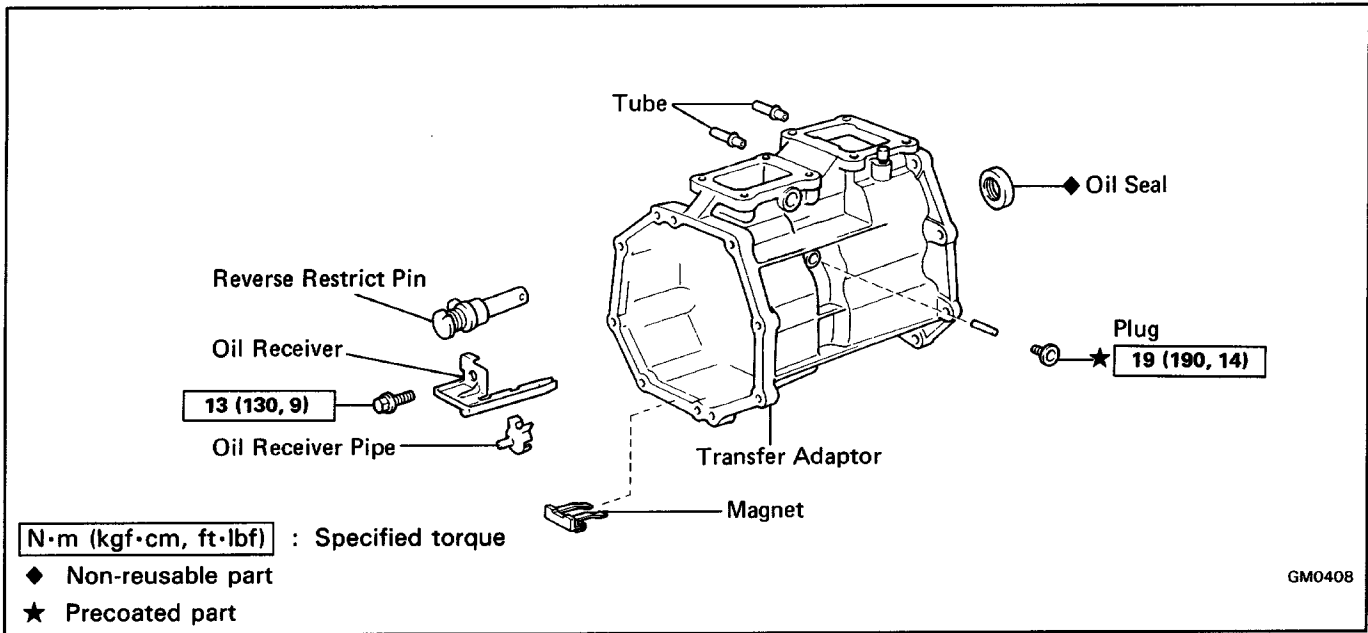

## REPLACEMENT OF OIL SEAL

**IF NECESSARY, REPLACE TRANSFER ADAPTOR OIL SEAL**

(a) Using a screwdriver, pry out the oil seal.

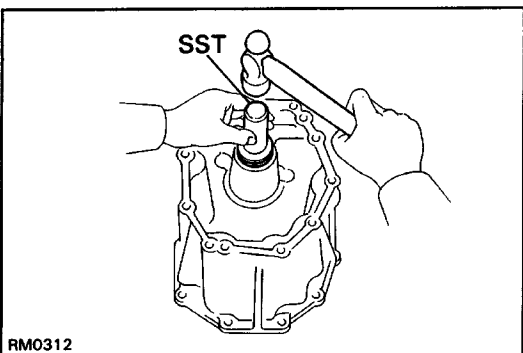

(b) Using SST and a hammer, drive in new oil seal.

SST 09325-12010

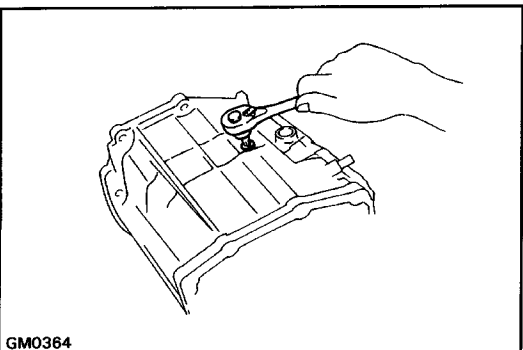

## INSPECTION AND REPLACEMENT OF REVERSE RESTRICT PIN

### 1. REMOVE THE REVERSE RESTRICT PIN

(a) Using a torx socket wrench remove the screw plug.

(Torx socket wrench T40 09042-00020)

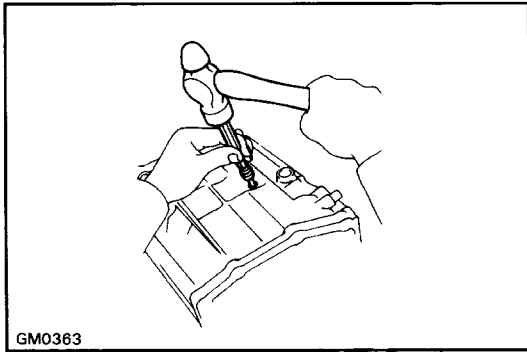

- (b) Using a pin punch and hammer, drive out the slotted spring pin.

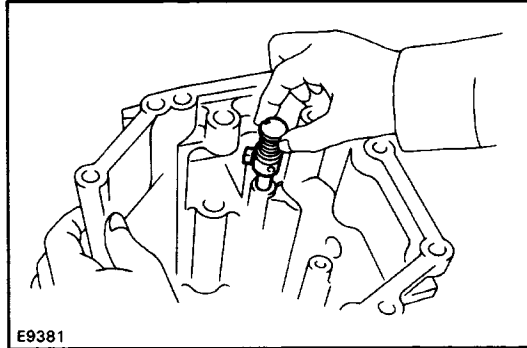

- (c) Remove the reverse restrict pin.

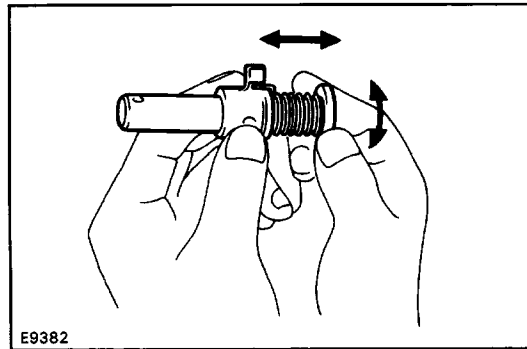

## 2. INSPECTION OF REVERSE RESTRICT PIN

Turn and push the reverse restrict pin by hand while applying force in axial direction.

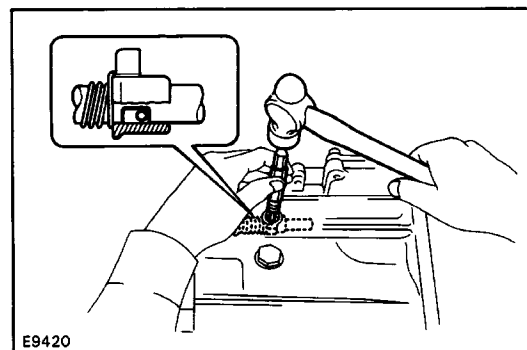

## 3. INSTALL THE REVERSE RESTRICT PIN

- (a) Install the reverse restrict pin to the extension housing or transfer adaptor.  
 (b) Using a pin punch and hammer, drive in the slotted spring pin as shown.

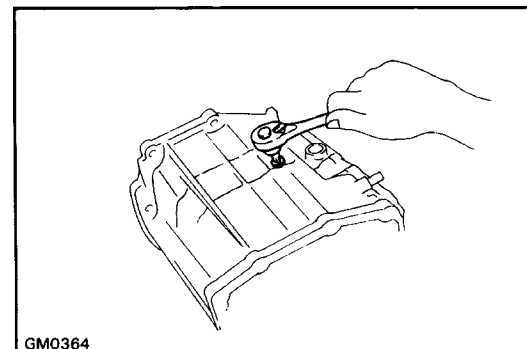

- (c) Apply liquid sealer to the plug threads.  
**Sealant: Part No. 08833-00080, THREE BOND 1344, LOCTITE 242 or equivalent**  
 (d) Using a torx socket wrench, install and torque the screw plug.  
 (Torx socket wrench T40 09042-00020)  
**Torque: 19 N – m (190 kgf –cm, 14 ft – lbf)**

## Front Bearing Retainer COMPONENTS

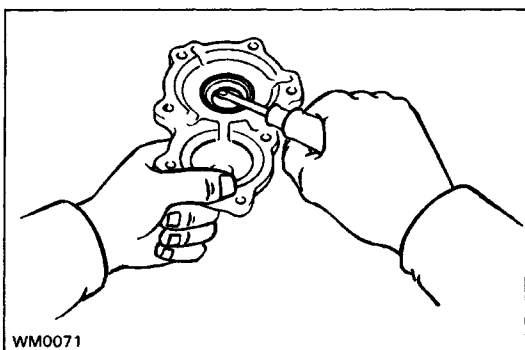
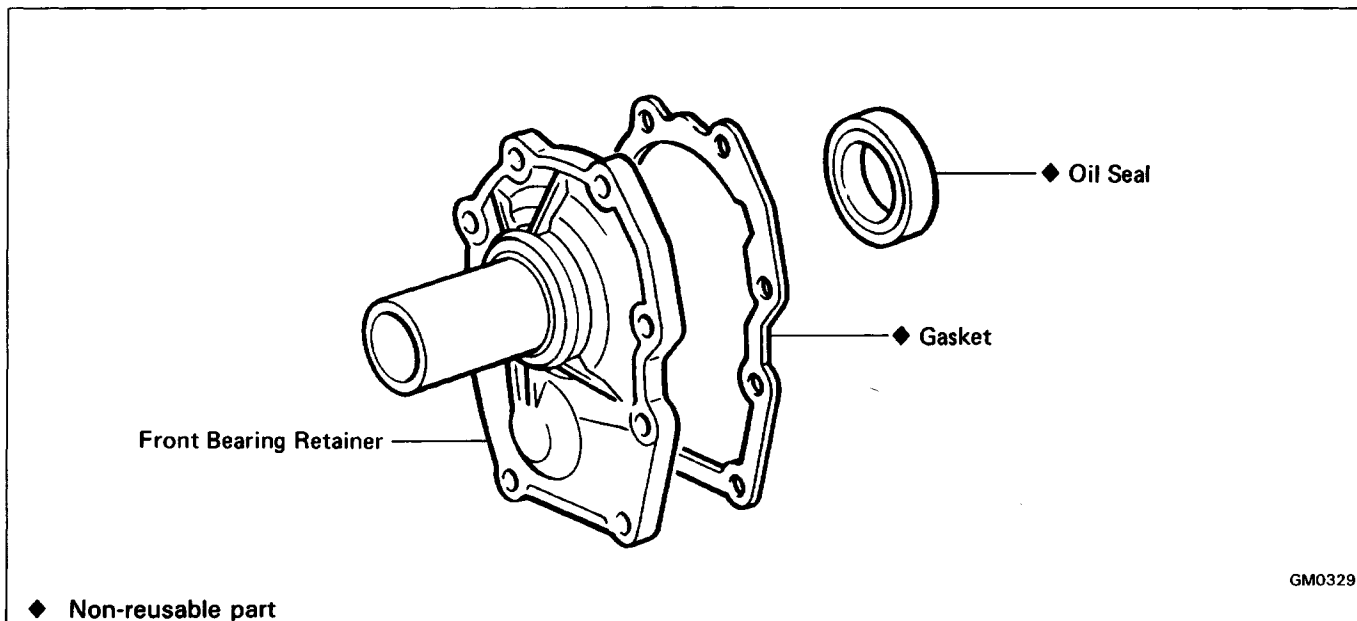

WM0071

### REPLACEMENT OF OIL SEAL IF NECESSARY, REPLACE FRONT BEARING RETAINER OIL SEAL

(a) Using a screwdriver, pry out the oil seal.

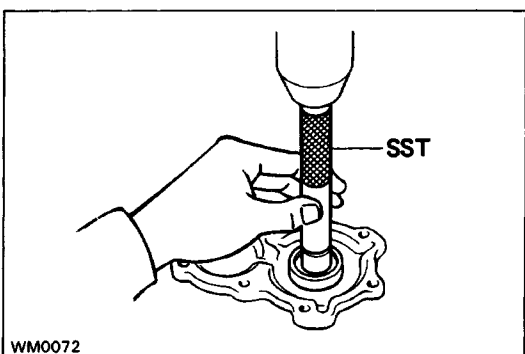

WM0072

(b) Using SST and a press, install a new oil seal.  
SST 09223-50010

**Oil seal depth: 12.2 – 13.2 mm (0.480 – 0.520 in.)**

**Transmission case installation surface**

(c) Coat the lip of the oil seal with MP grease.

## ASSEMBLY OF TRANSMISSION

(See pages [MT1-26](#) to [28](#))

HINT: Coat all of the sliding and rotating surface with gear oil before assembly.

### 1. INSTALL OUTPUT SHAFT TO INTERMEDIATE PLATE

- (a) Install the output shaft into the intermediate plate by pushing on the output shaft and tapping on the intermediate plate.

- (b) Using a snap ring expander, install the output shaft center bearing snap ring.

HINT: Be sure the snap ring is flush with the intermediate plate surface.

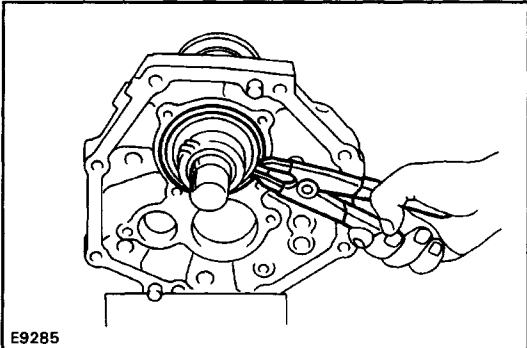
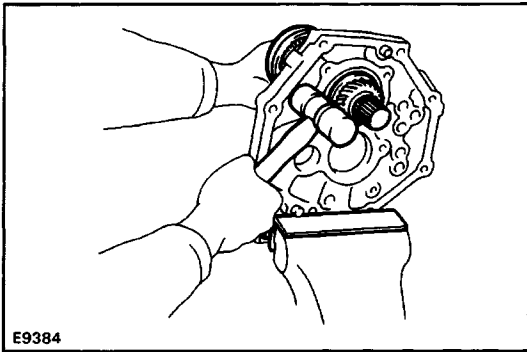

### 2. INSTALL INPUT SHAFT TO OUTPUT SHAFT

- (a) Apply MP grease to the 13-needle roller bearing and install them into the input shaft.

- (b) Install the input shaft to the output shaft with the synchronizer ring slots aligned with the shifting keys.

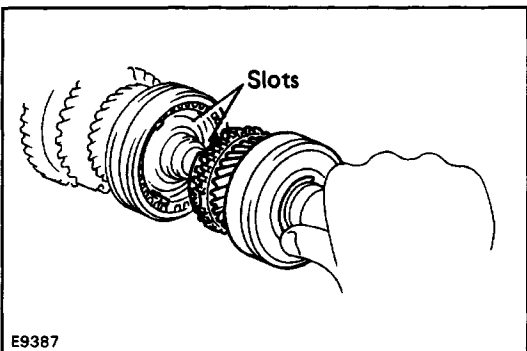
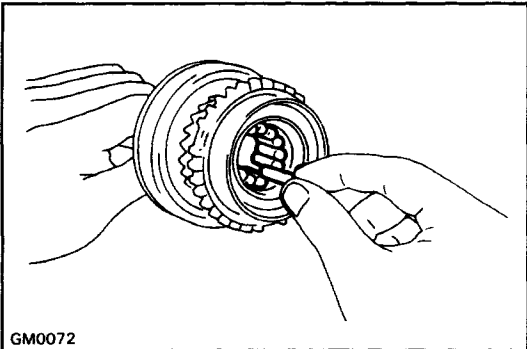

### 3. INSTALL COUNTER GEAR TO INTERMEDIATE PLATE

- (a) Using a snap ring expander, install snap ring to counter gear rear bearing.

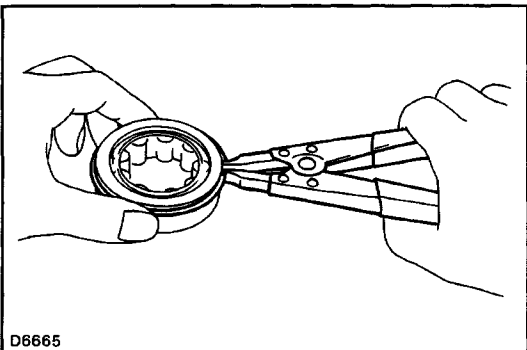

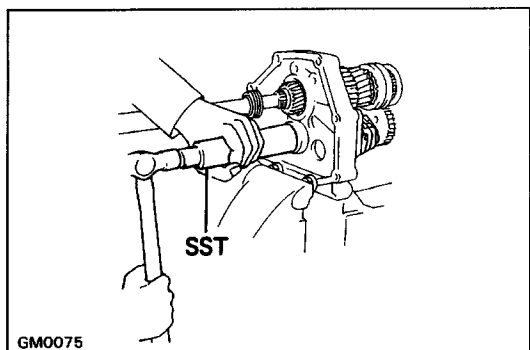

- (b) Install the counter gear into the intermediate plate while holding the counter gear and install the counter break bearing with SST.

SST 09316-60010

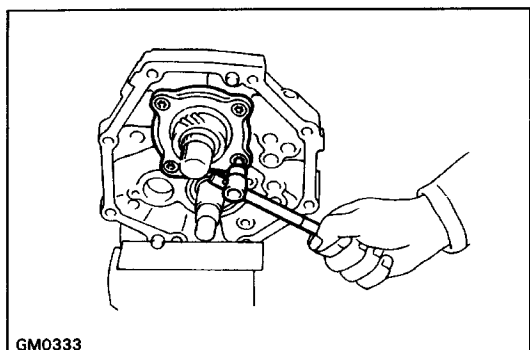

#### 4. INSTALL REAR BEARING RETAINER

Using a torx socket wrench, install and torque the screws.

(Torx socket wrench T40 09042-00020)

**Torque: 18 N-m (185 kgf-cm, 13 ft-lbf)**

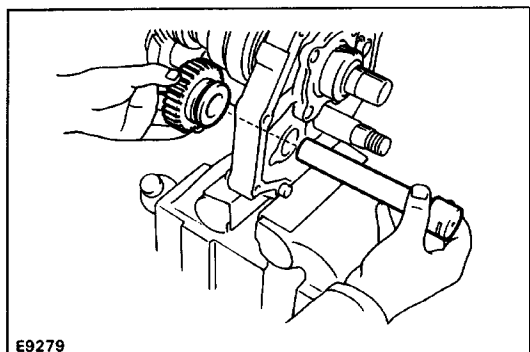

#### 5. INSTALL REVERSE IDLER GEAR AND SHAFT

- (a) Install reverse idler gear and shaft.

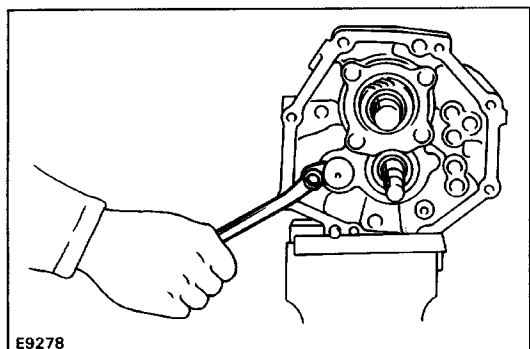

- (b) Install the shaft stopper and torque the bolt.

**Torque: 17 N-m (175 kgf-cm, 13 ft-lbf)**

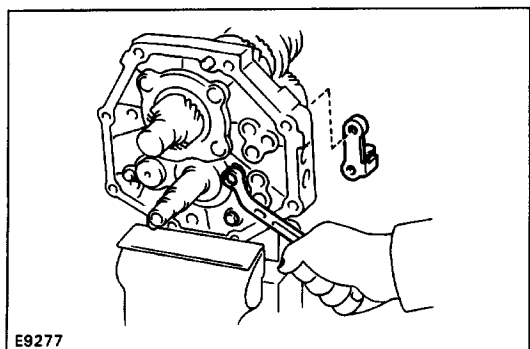

#### 6. INSTALL REVERSE SHIFT ARM BRACKET

Install the reverse shift arm bracket and torque the two bolts.

**Torque: 18 N-m (185 kgf-cm, 13 ft-lbf)**



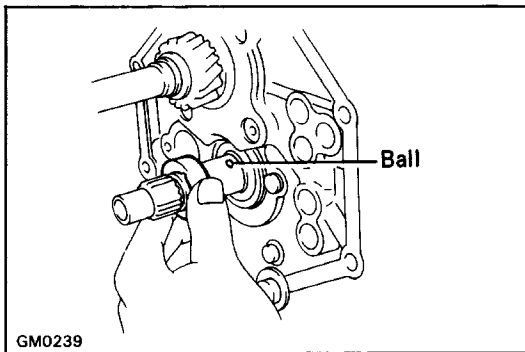

## 7. INSTALL BALL AND SPACER

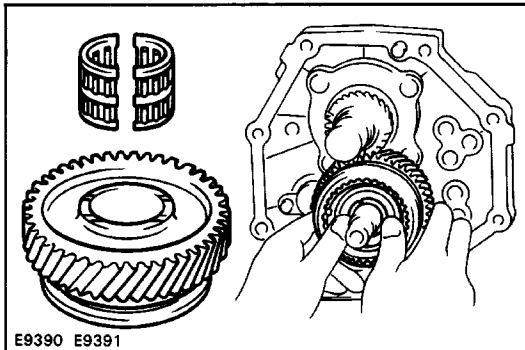

## 8. INSTALL COUNTER FIFTH GEAR WITH HUB SLEEVE NO.3 ASSEMBLY AND NEEDLE ROLLER BEARINGS

- (a) Apply gear oil to the needle roller bearings.
- (b) Install the counter 5th gear with hub sleeve No.3 and needle roller bearings.

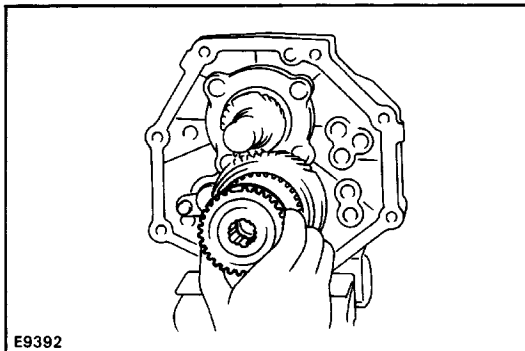

## 9. INSTALL SYNCHRONIZER RING AND GEAR SPLINE PIECE NO.5

- (a) Install the synchronizer ring on gear spline piece No. 5.

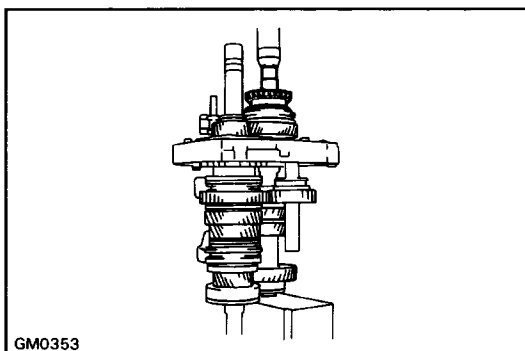

- (b) Dismount the intermediate plate from the vise.
- (c) Stand the transmission as shown.

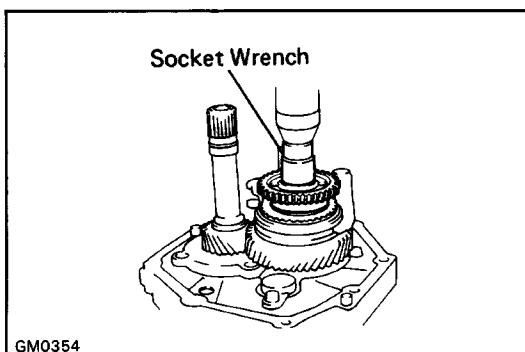

- (d) Using a press and 22 mm socket wrench, install gear spline piece No.5 with the synchronizer ring slots aligned with the shifting keys.
- (e) Mount the intermediate plate to the vise.

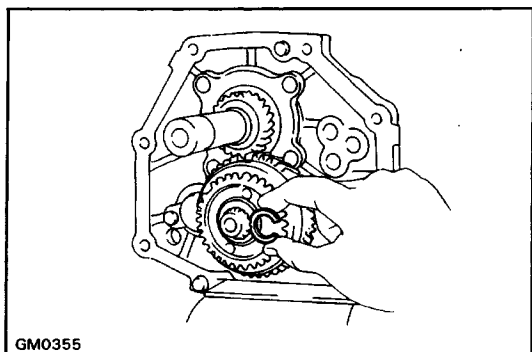

## 10. INSTALL SNAP RING

(a) Select snap ring that will allow minimum axial play.

Mark	Thickness mm (in.)
A	2.80 – 2.85 (0.110 – 0.112)
B	2.85 – 2.90 (0.112 – 0.114)
C	2.90 – 2.95 (0.114 – 0.116)
D	2.95 – 3.00 (0.116 – 0.118)
E	3.00 – 3.05 (0.118 – 0.120)
F	3.05 – 3.10 (0.120 – 0.122)
G	3.10 – 3.15 (0.122 – 0.124)

(b) Using a brass bar and hammer, install the snap ring.

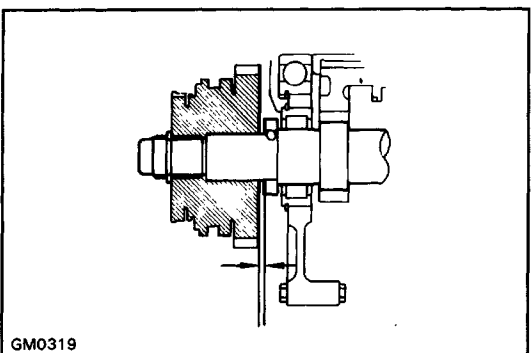
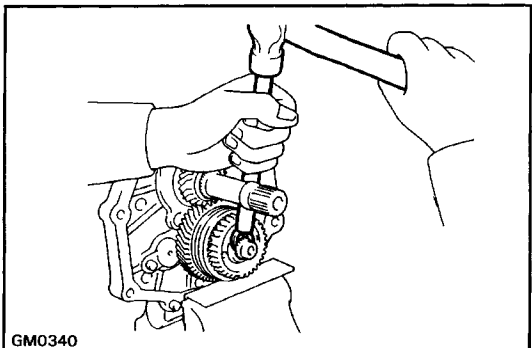

## 11. MEASURE COUNTER FIFTH GEAR THRUST CLEARANCE

Using a feeler gauge, measure the counter 5th gear thrust clearance.

**Standard clearance:** 0.10 – 0.30 mm  
(0.0039 – 0.0118 in.)

**Maximum clearance:** 0.30 mm (0.0118 in.)

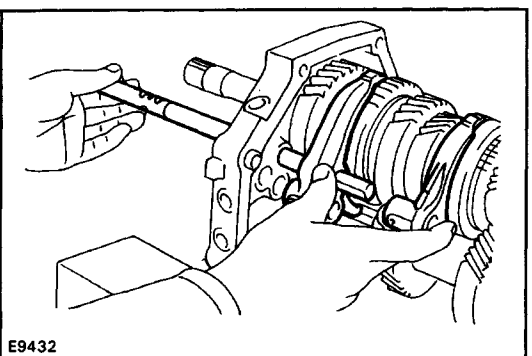

## 12. INSTALL SHIFT FORK SHAFT NO.2 AND SHIFT FORK NO.2

(a) Install the shift fork No. 1 and No. 2.

(b) Install the shift fork shaft No.2 through the intermediate plate and shift forks.

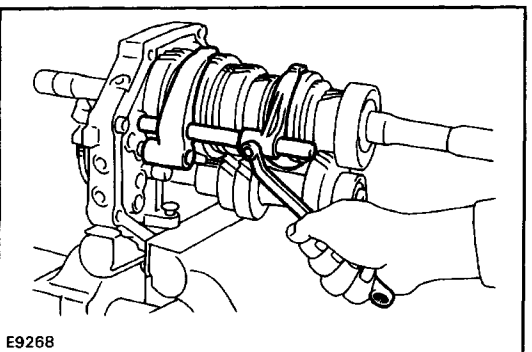

(c) Install the shift fork No.2 set bolt and torque the bolt.

**Torque:** 20 N-m (200 kgf-cm, 14 ft-lbf)

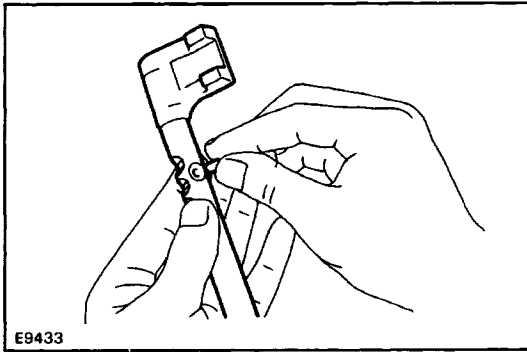

E9433

### 13. INSTALL SHIFT FORK SHAFT NO. 1 AND SHIFT FORK NO. 1

- (a) Apply MP grease to the interlock pin No. 2 and install them into the shift fork shaft No. 1.

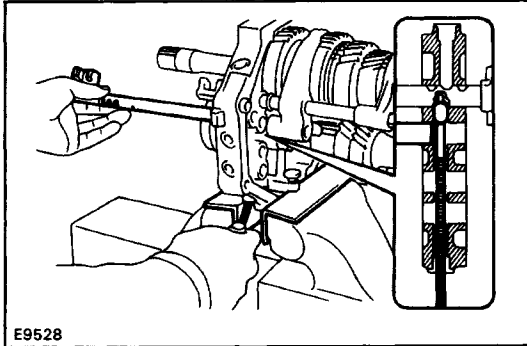

E9528

- (b) Using a magnetic finger, install the interlock pin No-1 to intermediate plate.

- (c) Install shift fork shaft No. 1 through the intermediate plate and shift fork No. 1.

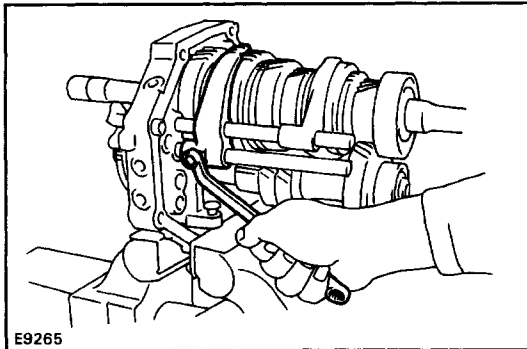

E9265

- (d) Install the shift fork No. 1 set bolt and torque the bolt.

**Torque: 20 N-m (200 kgf -cm, 14 ft-lbf)**

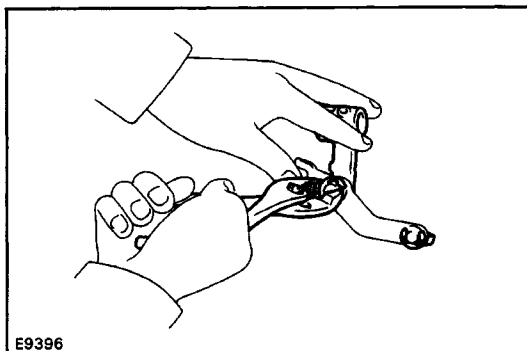

E9396

### 14. INSTALL SHIFT FORK SHAFT NO.3 AND REVERSE SHIFT FORK

- (a) Install the shift arm shoe, shift fork and two E-rings to reverse shift arm.

- (b) Install the reverse shift arm to reverse shift arm bracket.

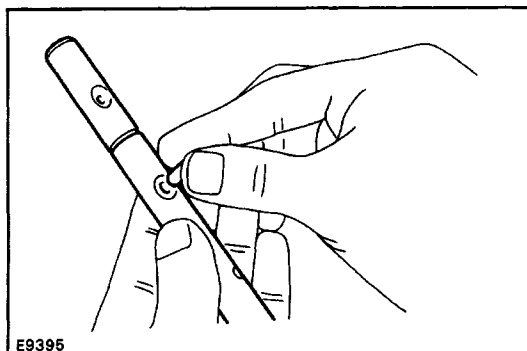

E9395

- (c) Apply MP grease to the interlock pin No. 2 and install them into the shift fork shaft No.3.

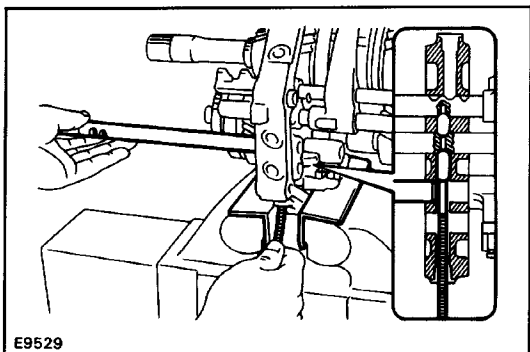

(d) Using a magnetic finger, install the interlock pin No. 1 to the intermediate plate.

(e) Install the shift fork shaft No.3 through the intermediate and reverse shift fork.

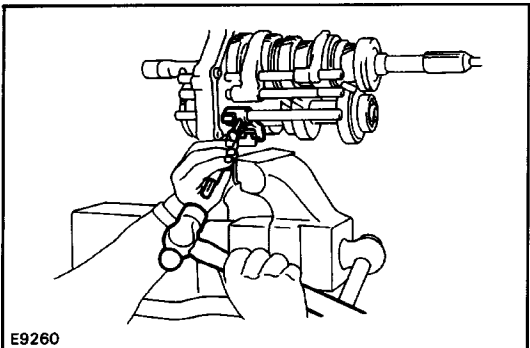

(f) Using a pin punch and hammer, drive in the slotted spring pin.

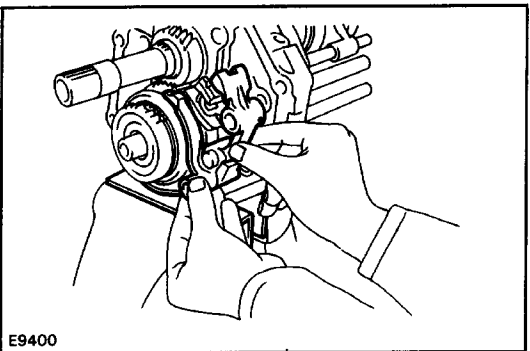

#### 15. INSTALL REVERSE SHIFT HEAD, FIFTH SHIFT FORK, SHIFT FORK SHAFT NO.4 AND NO.5

(a) Install the reverse shift head to shift fork shaft No.3.

(b) Install the shift fork No.3.

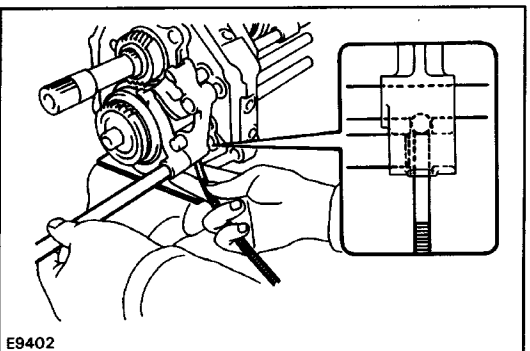

Using a magnetic finger, install the ball to reverse shift head.

(d) Install the shift fork shaft No.4 as shown.

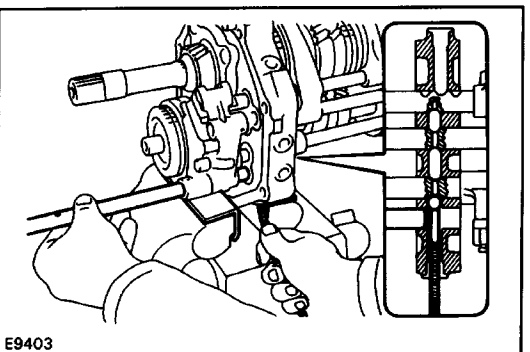

(e) Using a magnetic finger, install the interlock ball No.1 to intermediate plate.

(f) Install the shift fork shaft No.4 through the intermediate plate.

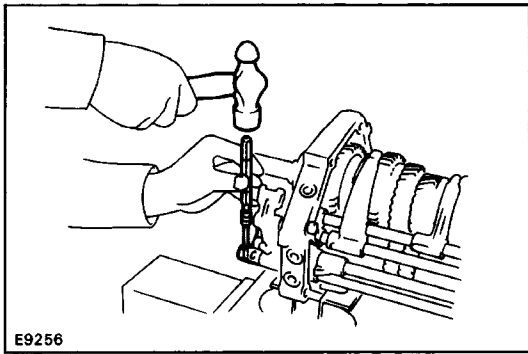

(g) Using a pin punch and hammer, drive in the slotted spring pin to the shift fork Rlo.3.

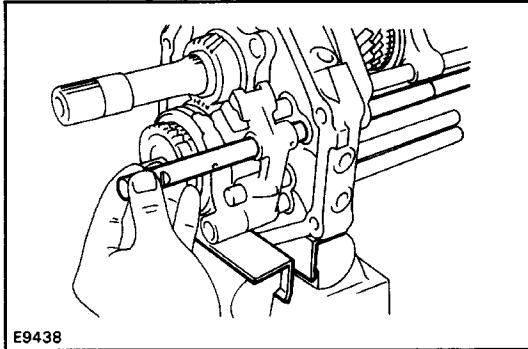

(h) Install the shift fork shaft No.5 through the reverse shift head and intermediate plate.

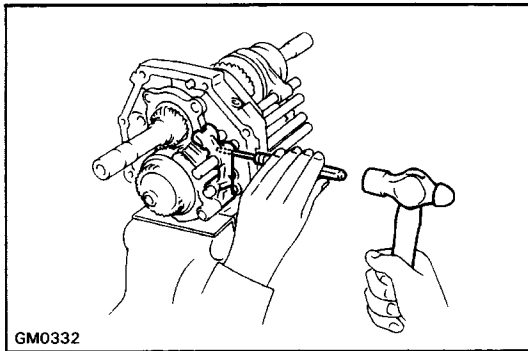

(i) Using a pin punch and hammer, drive in the slotted spring pin to the reverse shift head.

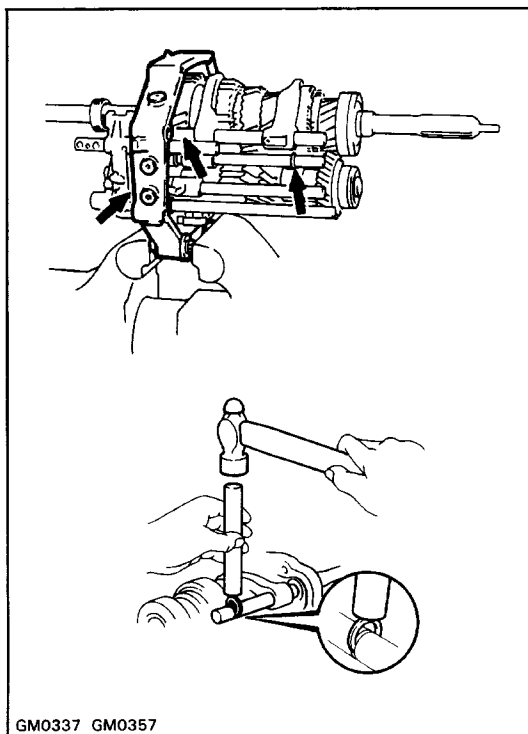

## 16. INSTALL SHIFT FORK SHAFT SNAP RINGS

Using a brass bar and hammer tap in the three snap rings.

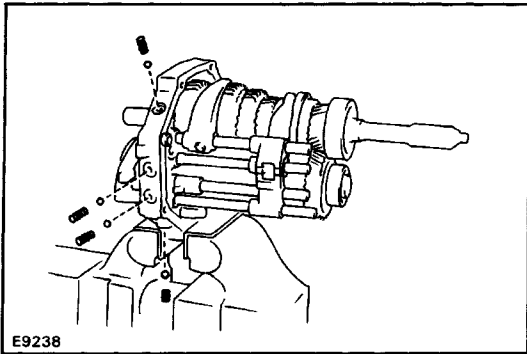

**17. INSTALL LOCKING BALLS, SPRINGS AND SCREW PLUGS**

- (a) Install the four locking balls and four springs.

HINT: Install the short spring into the bottom of the intermediate plate.

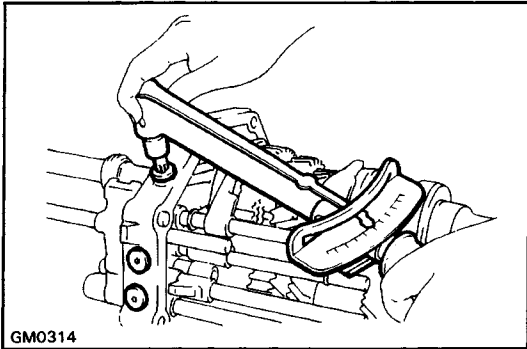

- (b) Apply liquid sealer to the plug threads.  
**Sealant: Part No. 08833-00080, THREE BOND 1344 LOCTITE 242 or equivalent**

- (c) Install the screw plugs and torque the screw plugs with a torx socket wrench.

(Torx socket wrench T40 09042-00020)

**Torque: 19 N – m (190 kgf – cm, 14 ft – lbf )**

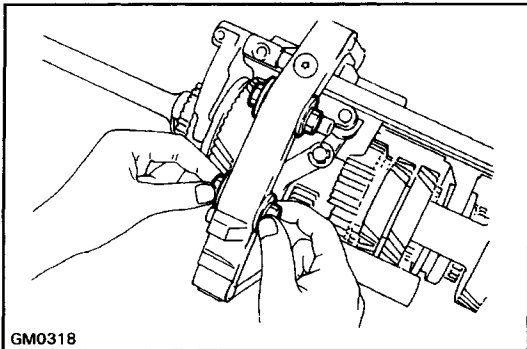

**18. DISMOUNT INTERMEDIATE PLATE FROM VISE**

- (a) Dismount the intermediate plate from the vise.
- (b) Remove the bolts, nuts and plate washers.

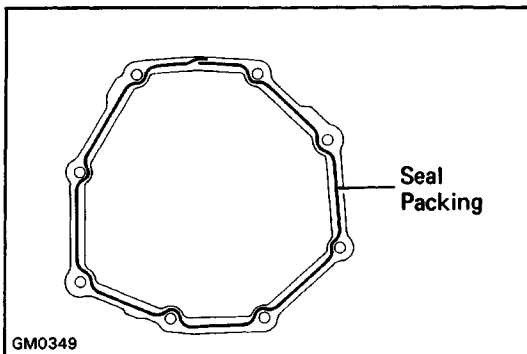

**19. INSTALL TRANSMISSION CASE**

- (a) Remove the any packing material and be careful not to drop oil on the contacting surfaces of the transmission case or intermediate plate.

- (b) Apply seal packing to the transmission case as shown.

**Seal packing: Part No. 08826-00090, THREE BOND 1281 or equivalent**

HINT: Install the transmission case as soon as the seal packing is applied.

- (c) Stand the intermediate plate as shown.

- (d) Install the transmission case to the intermediate plate as shown.

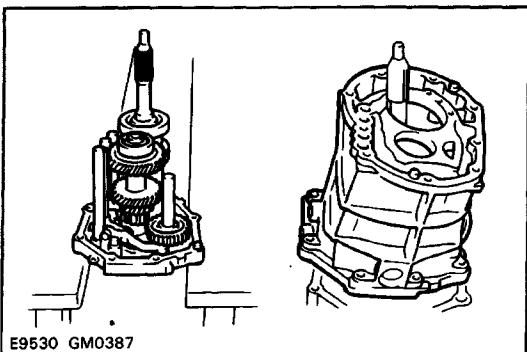

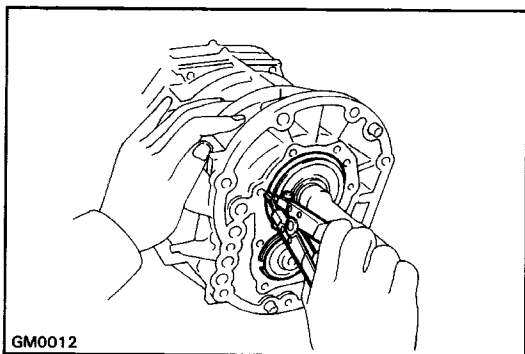

## 20. INSTALL FRONT BEARING RETAINER

(a) Using a snap ring expander, install the two snap rings to input shaft bearing and counter gear front bearing.

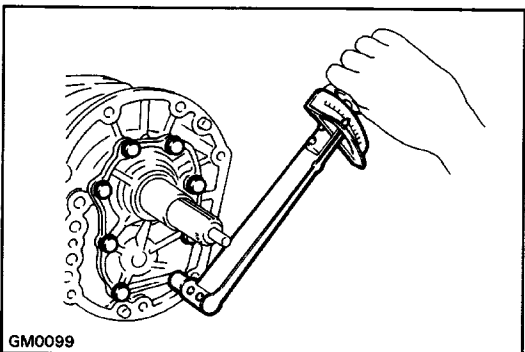

(b) Install the bearing retainer with a new gasket.

(c) Apply liquid sealer to the bolt threads.

**Sealant: Part No. 08833-00080, THREE BOND 1344**

**LOCTITE 242 or equivalent**

(d) Install and torque the bolts.

**Torque: 17 N – m (170kgf – cm, 12ft – lbf)**

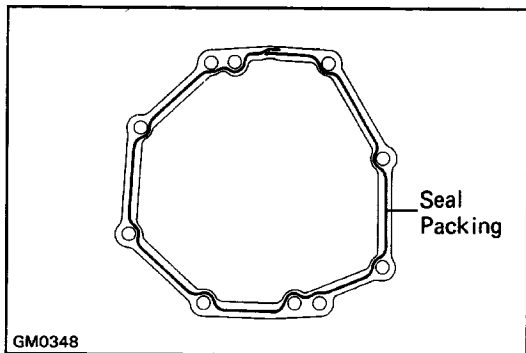

## 21. INSTALL TRANSFER ADAPTOR, SHIFT LEVER SHAFT AND SHIFT LEVER HOUSING

(a) Remove the any packing material and be careful not to drop oil on the contacting surfaces of the transfer adaptor or intermediate plate.

(b) Apply seal packing to the transfer adaptor as shown.

**Seal packing: Part No. 08826-00090, THREE BOND 1281 or equivalent**

**HINT:** Install the transfer adaptor as soon as the seal packing is applied.

(c) Install and torque the transfer adaptor with the eight bolts.

**Torque: 37 N-m (380 kgf-cm, 27 ft-lbf)**

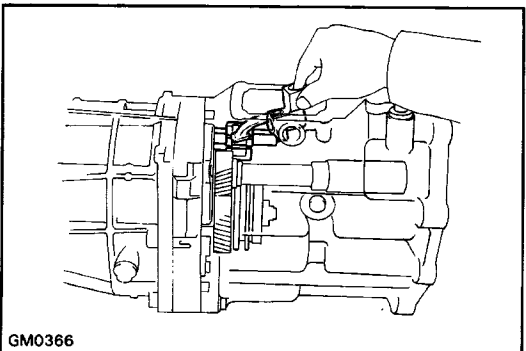
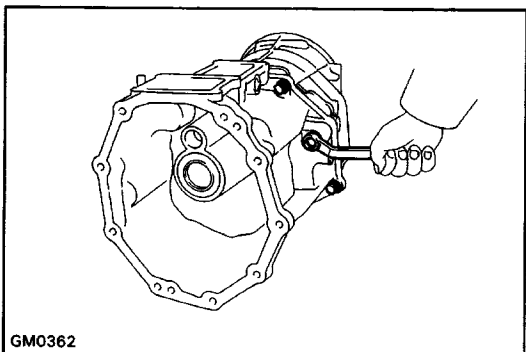

(d) Install the shift lever housing to the transfer adaptor and connect the fork shafts.

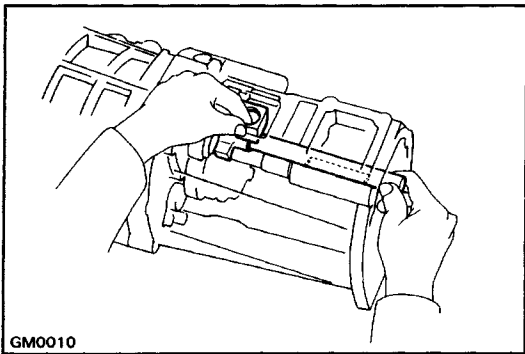

- (e) Install the shift lever shaft to the transfer adaptor and shift lever housing.

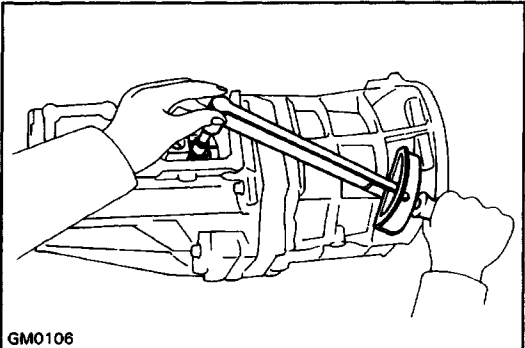

- (f) Install and torque the shift lever housing bolt.

**Torque: 38 N-m (390 kgf-cm, 28 ft-lbf)**

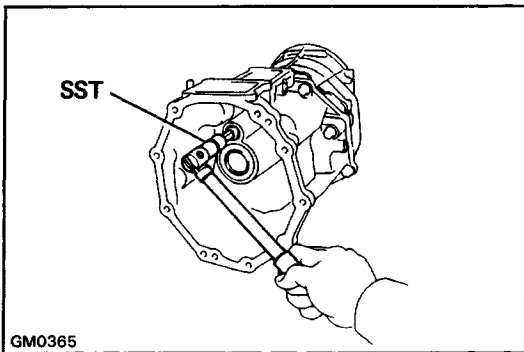

- (g) Using SST, install and torque the plug.

SST 09923-00010

**Torque: 37 N-m (380 kgf-cm, 27 ft-lbf)**

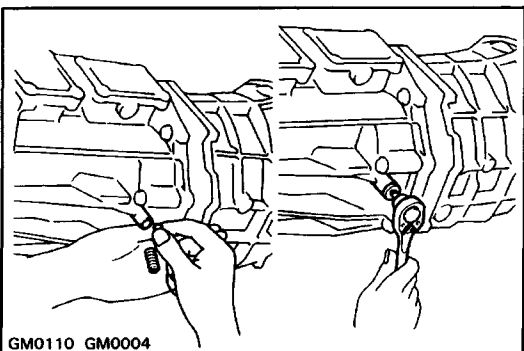

## 22. INSTALL LOCKING BALL, SPRING AND SCREW PLUG

- (a) Apply liquid sealer to the plug threads.

**Sealant: Part No. 08833-00080, THREE BOND 1344, LOCTITE 242 or equivalent**

- (b) Install the locking ball, spring and plug, and torque the plug.

(Torx socket wrench T40 09042-00020)

**Torque: 19 N - m (190 kgf - cm, 14 ft - lbf )**

## 23. AFTER INSTALLING TRANSFER ADAPTOR CHECK FOLLOWING ITEMS

- (a) Check to see that the input and output shafts rotate smoothly.
- (b) Check to see that shifting can be made smoothly to all positions.

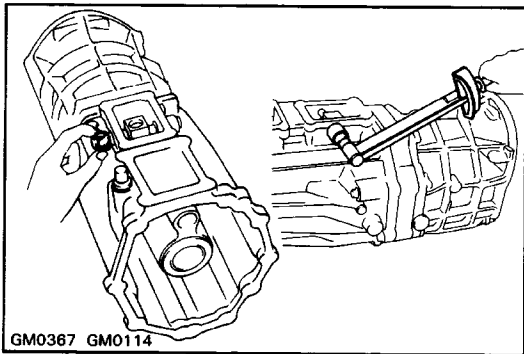

**24. INSTALL RESTRICT PINS**

- (a) Install the black pin on the reverse gear/5th gear side.
  - (b) Install another pin and torque the pins.
- Torque: 27 N-m (280 kgf-cm, 20 ft-lbf)**

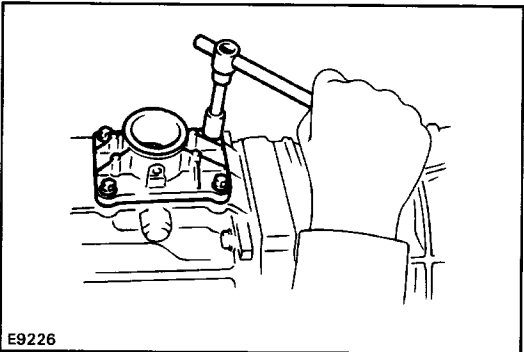
**25. INSTALL TRANSMISSION SHIFT LEVER CONTROL RETAINER**

- (a) Install shift lever control retainer and new gasket.
  - (b) Install four bolts and torque the bolts.
- Torque: 18 N-m (185 kgf-cm, 13 ft-lbf)**

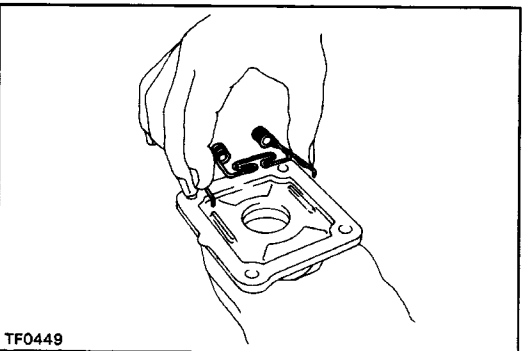
**26. INSTALL TRANSFER SHIFT LEVER CONTROL RETAINER**

- (a) Install the select return spring from the retainer.
  - (b) Install shift lever control retainer and new gasket.
  - (c) Install four bolts and torque the bolts.
- Torque: 18 N-m (185 kgf-cm, 13 ft-lbf)**

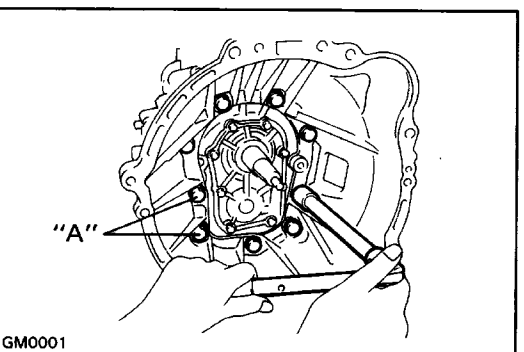
**27. INSTALL CLUTCH HOUSING**

- (a) Install clutch housing.
  - (b) Apply liquid sealer to the "A" bolt threads.  
**Sealant: Part No. 08833-00080, THREE BOND 1344, LOCTITE 242 or equivalent.**
  - (c) Install nine bolts and torque the bolts.
- Torque: 37 N - m (380 kgf - cm, 27 ft - lbf )**

**28. INSTALL BACK-UP LIGHT SWITCH**

**Torque: 37 N - m (380 kgf - cm, 27 ft-lbf)**

**29. INSTALL RELEASE FORK AND BEARING**

(See page [CL-14](#))

# DISASSEMBLY OF TRANSMISSION (R150 AND R 150F TRANSMISSIONS) Components

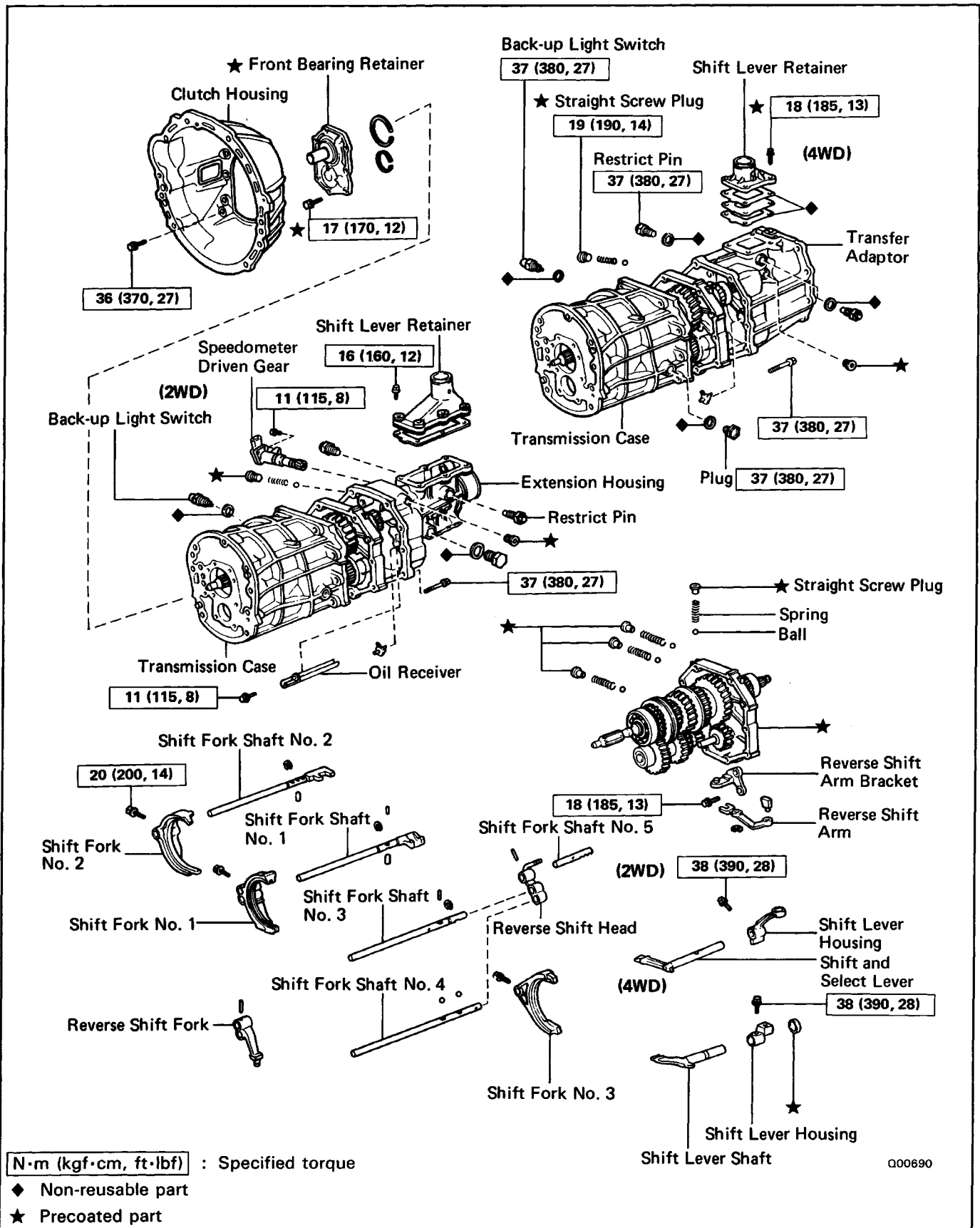

## Disassembly of Transmission

(See pages [MT1–67](#), 68)

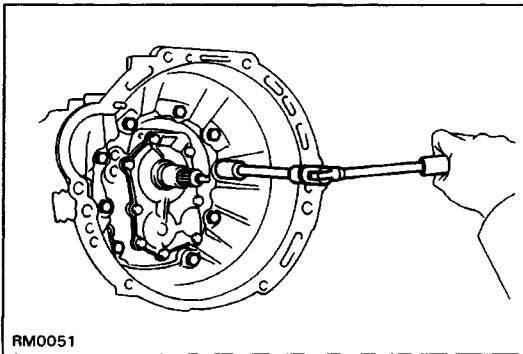

1. REMOVE RELEASE FORK AND BEARING
2. REMOVE BACK-UP LIGHT SWITCH, SPEEDOMETER DRIVEN GEAR (2WD). SHIFT LEVER RETAINER AND RESTRICT PINS
3. REMOVE CLUTCH HOUSING FROM TRANSMISSION CASE

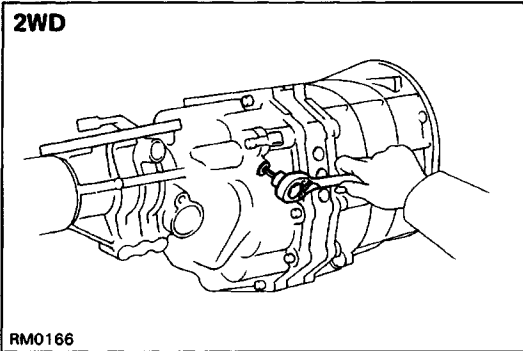

4. REMOVE STRAIGHT SCREW PLUG, SPRING AND BALL

- (a) Using a torx socket wrench, remove the screw plug from the extension housing or transfer adaptor.  
(Torx socket wrench T40 09042–00020)

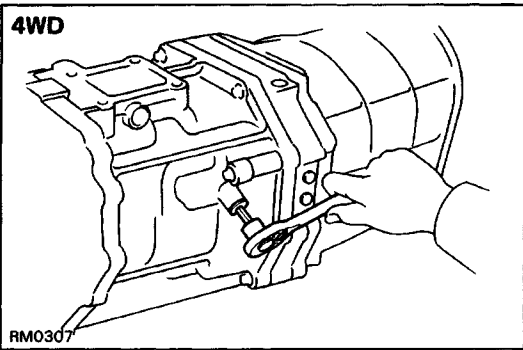

- (b) Using a magnetic finger, remove the spring and ball.

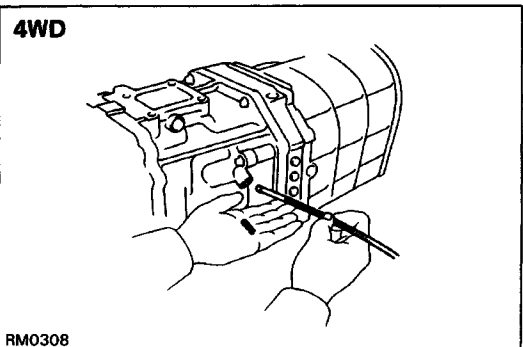
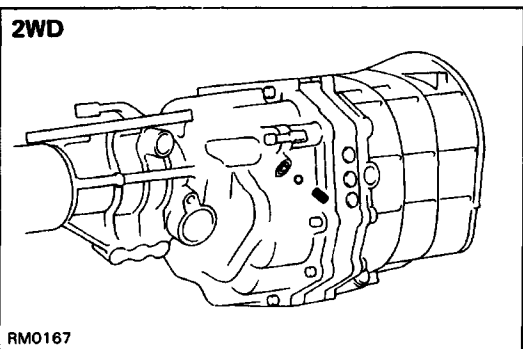

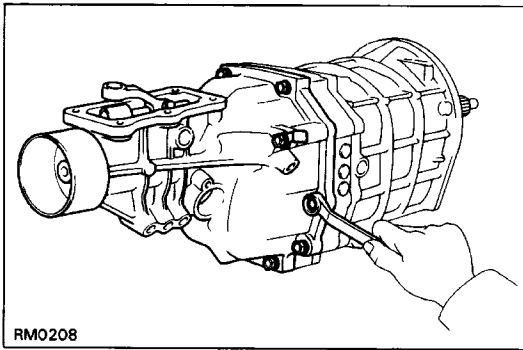

### 5.-1 (2WD) REMOVE EXTENSION HOUSING

(a) Remove the ten bolts.

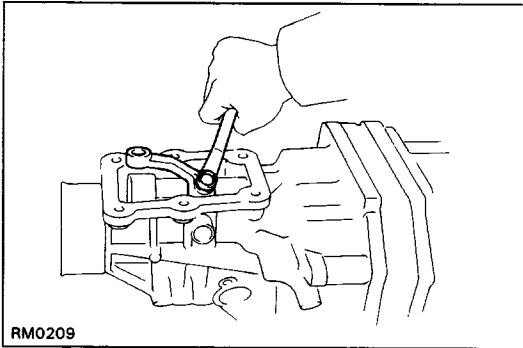

(b) Remove the shift lever housing set bolt.

(c) Using a plastic hammer, tap the extension housing and remove the shift lever housing and shift and select lever.

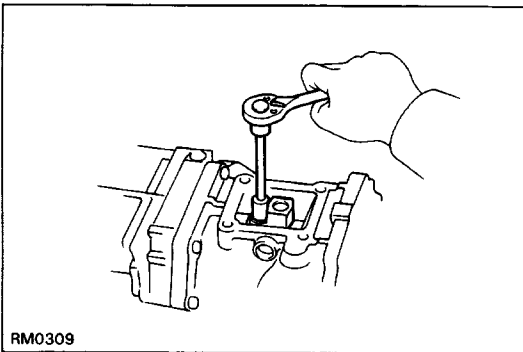

### 5.-2 (4WD) REMOVE TRANSFER ADAPTOR

(a) Remove the shift lever housing set bolt.

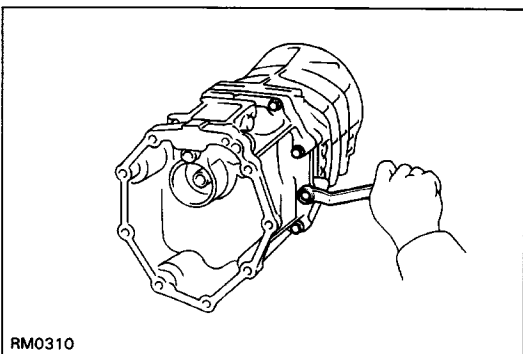

(b) Remove the ten bolts.

(c) Using a plastic hammer, tap the transfer adaptor and remove the shift lever housing and shift and select lever.

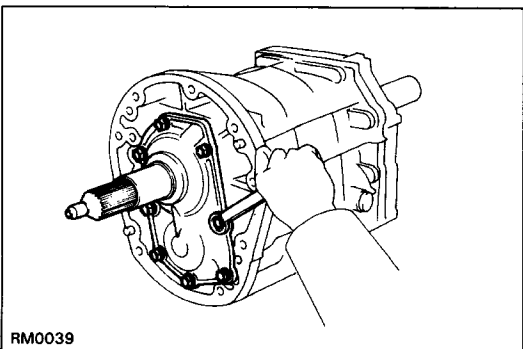

### 6. REMOVE FRONT BEARING RETAINER

(a) Remove the eight bolts.

(b) Using a plastic hammer, tap the front bearing retainer.

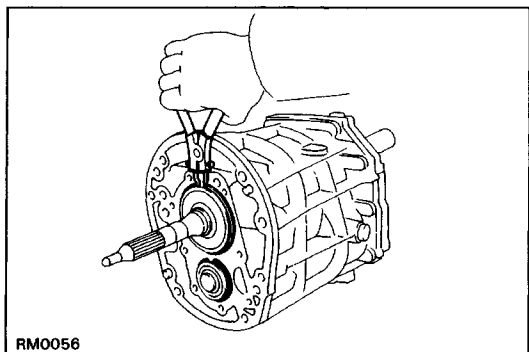

### 7. REMOVE BEARING SNAP RINGS

Using a snap ring expander, remove the two snap rings.

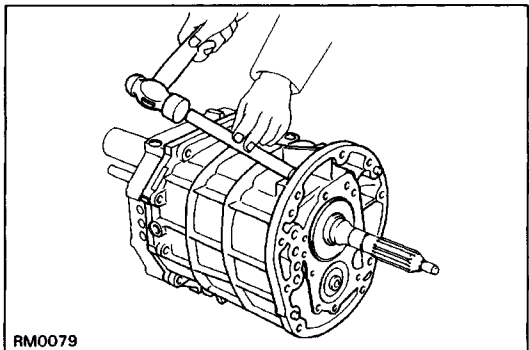

### 8. SEPARATE INTERMEDIATE PLATE FROM TRANSMISSION CASE

- (a) Using a brass bar and hammer, carefully tap off the transmission case.
- (b) Remove the transmission case from the intermediate plate.

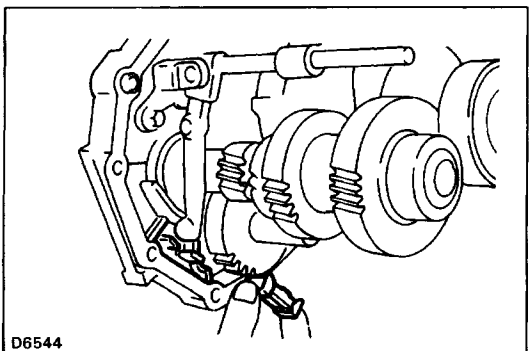

### 9. REMOVE MAGNET FROM INTERMEDIATE PLATE

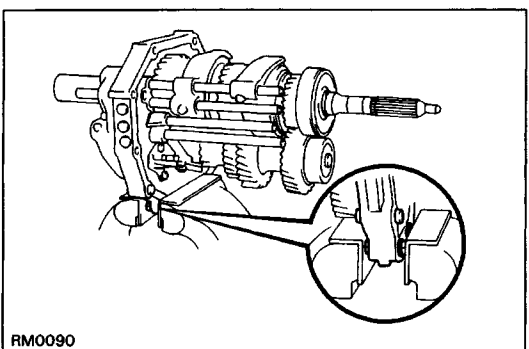

### 10. MOUNT INTERMEDIATE PLATE IN VISE

- (a) Use two clutch housing bolts, plate washers and suitable nuts as shown.

**NOTICE:** Install the plate washers in reverse of normal. Increase or decrease plate washers so that the bolt tip and front tip surface of the nut are aligned.

- (b) Mount the intermediate plate in a vise.

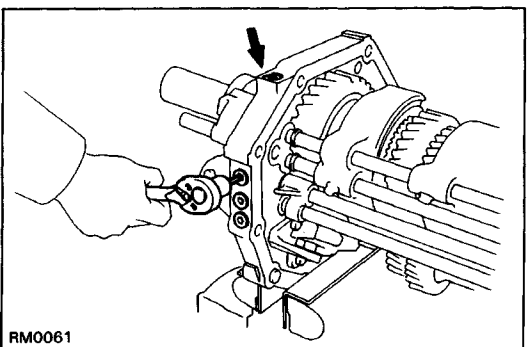

### 11. REMOVE STRAIGHT SCREW PLUGS, LOCKING BALLS AND SPRINGS

- (a) Using a torx socket wrench, remove the four plugs.  
(Torx socket wrench T40 09042-00020)

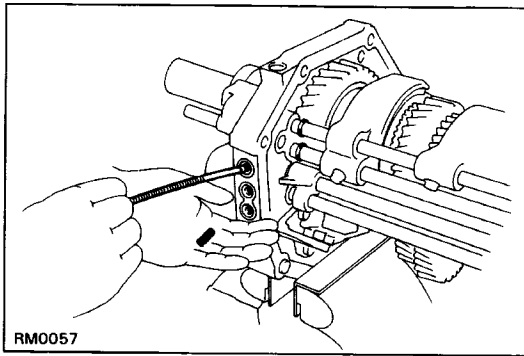

(b) Using a magnetic finger, remove the four springs and balls.

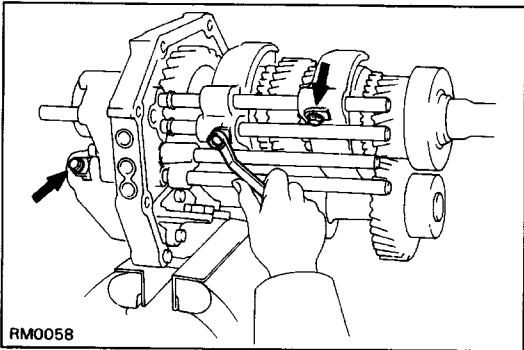

## 12. REMOVE SHIFT FORK SET BOLTS

Remove the three bolts.

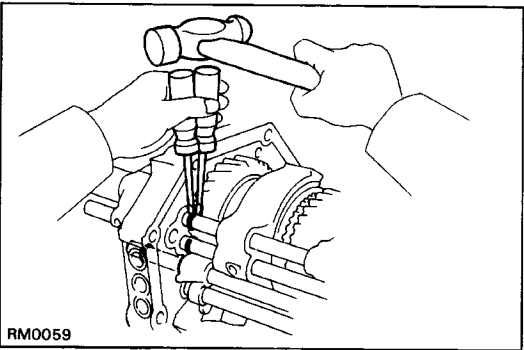

## 13. REMOVE SNAP RINGS

Using two screwdrivers and a hammer, tap out the three snap rings.

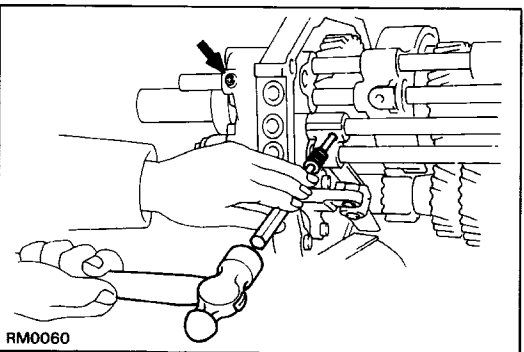

## 14. REMOVE SLOTTED SPRING PINS

Using a pin punch and hammer, drive out the two pins.

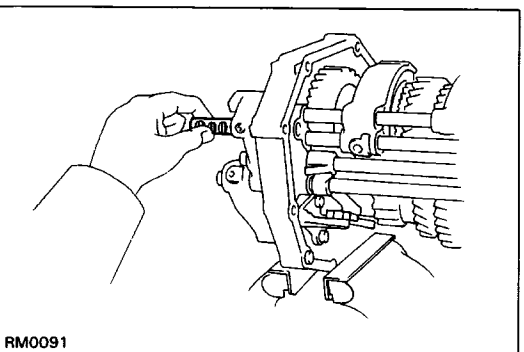

## 15. REMOVE SHIFT FORK SHAFT NO.5

Pull out the shift fork shaft No.5 from the intermediate plate.

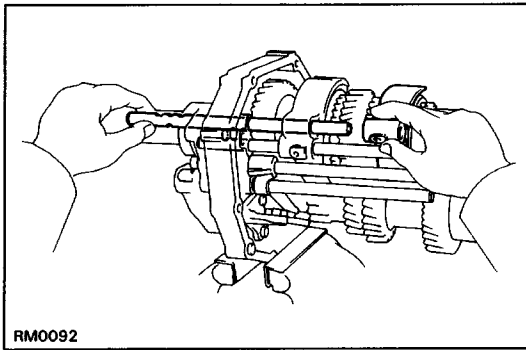

**16. REMOVE SHIFT FORK SHAFT NO.2 AND SHIFT FORK**

- (a) Pull out the shift fork shaft No. 2 from the intermediate plate.
- (b) Remove the shift fork No.2.
- (c) Using a magnetic finger, remove the interlock pin from the intermediate plate.

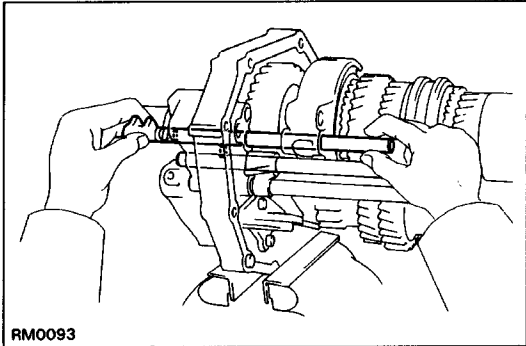

**17. REMOVE SHIFT FORK SHAFT NO. 1**

- (a) Pull out the shift fork shaft No. 1 from the intermediate plate.
- (b) Using a magnetic finger, remove the interlock pins from the shaft hole and intermediate plate.

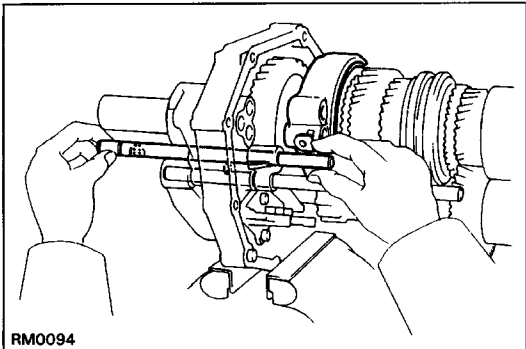

**18. REMOVE SHIFT FORK SHAFT NO.3 AND SHIFT FORK NO. 1**

- (a) Pull out the shift fork shaft No.3 from the intermediate plate.
- (b) Remove the shift fork No. 1.
- (c) Using a magnetic finger, remove the interlock pin and locking ball from the shaft hole and intermediate plate.

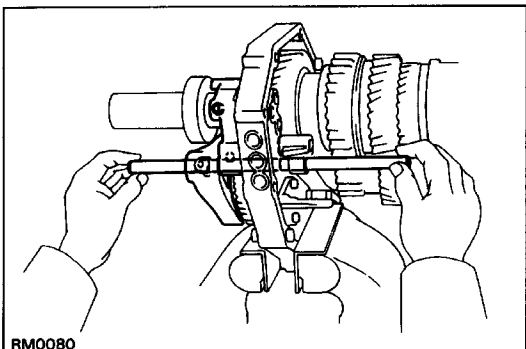

**19. REMOVE SHIFT FORK SHAFT NO.4, SHIFT FORK NO.3 AND REVERSE SHIFT HEAD**

- (a) Pull out the shift fork shaft No.4 from the intermediate plate.
- (b) Remove the reverse shift head and locking ball.
- (c) Remove the shift fork No.3.

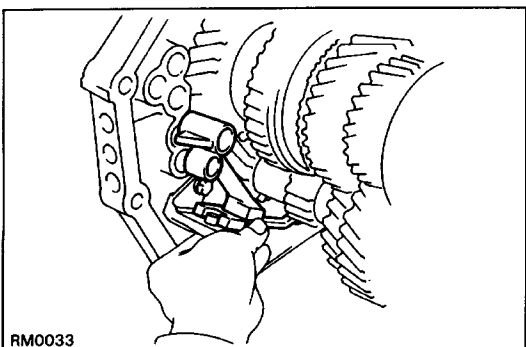

**20. REMOVE REVERSE SHIFT ARM FROM REVERSE SHIFT ARM BRACKET**

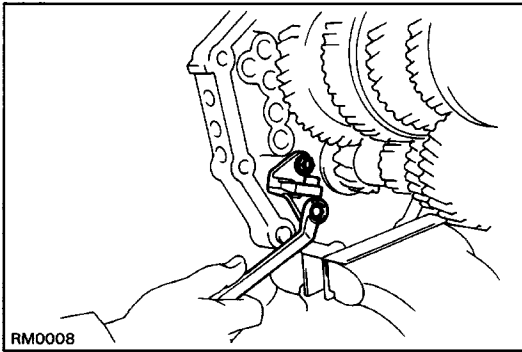
**21. REMOVE REVERSE SHIFT ARM BRACKET**

Remove the two bolts and the reverse shift arm bracket.

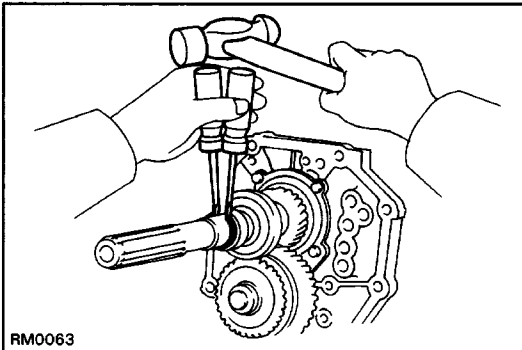
**22.-1 (2WD)****REMOVE SPEEDOMETER DRIVE GEAR**

- (a) Using two screwdrivers and a hammer, tap out the rear snap ring.
- (b) Remove the speedometer drive gear and ball.
- (c) Using two screwdrivers and a hammer, tap out the front snap ring.

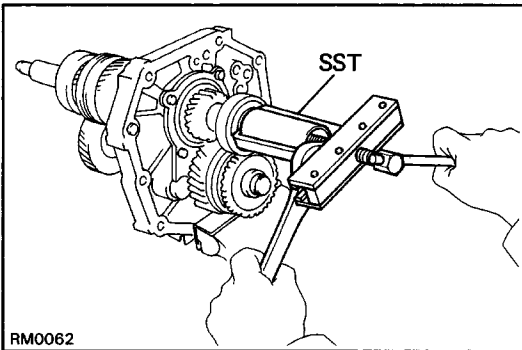
**22.-2 (4WD)****REMOVE SLEEVE FROM OUTPUT SHAFT**

Using SST, remove the sleeve from the output shaft.  
SST 09213-36020

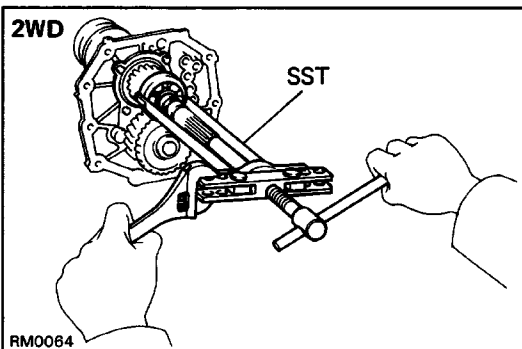
**23. REMOVE OUTPUT SHAFT REAR BEARING**

- (a) Using two screwdrivers and a hammer, tap out the snap ring.
- (b) Using SST, remove the rear bearing.  
SST 09950-20017

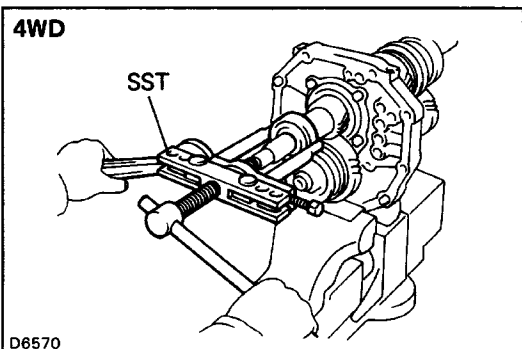



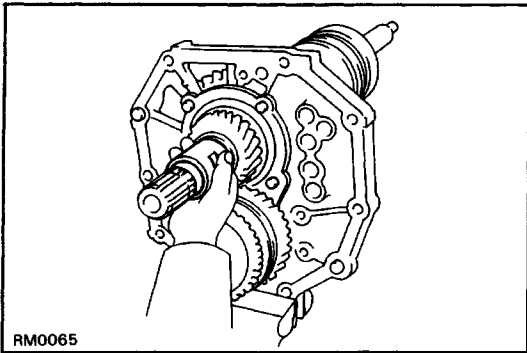

**24. REMOVE SPACER**

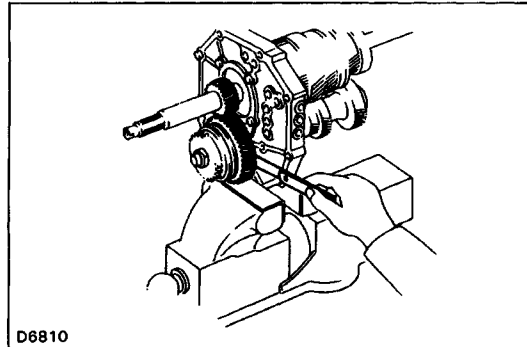

**25. MEASURE COUNTER FIFTH GEAR THRUST CLEARANCE**

Using a feeler gauge, measure the counter 5th gear thrust clearance.

Standard clearance: 0.10 – 0.35 mm

(0.0039 – 0.0138 in.)

Maximum clearance: 0.40 mm (0.0157 in.)

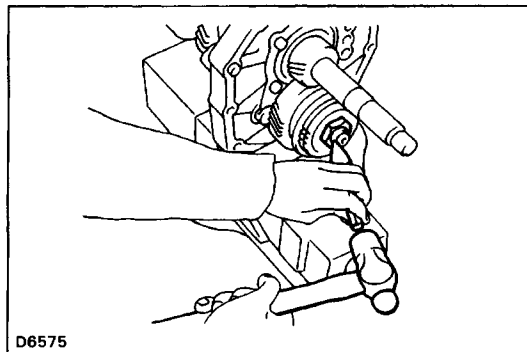

**26. REMOVE GEAR SPLINE PIECE NO.5, SYNCHRONIZER RING, NEEDLE ROLLER BEARING AND COUNTER FIFTH GEAR WITH HUB SLEEVE NO.3**

(a) Engage the gear double meshing.

(b) Using a hammer and chisel, loosen the staked part of the nut.

(c) Remove the lock nut.

(d) Disengage the gear double meshing.

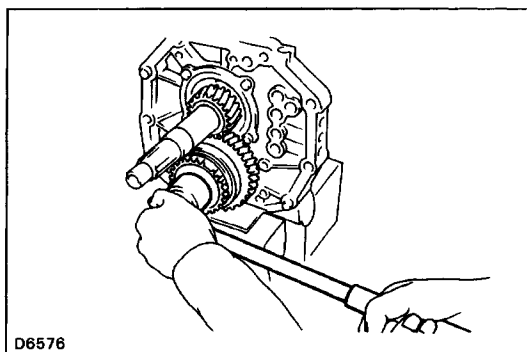

(e) Using SST, remove the gear spline piece No. 5.

**SST 09213-31021**

(f) Remove the counter 5th gear with hub sleeve No-3.

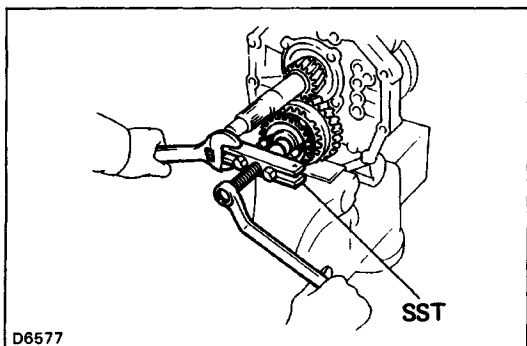

**27. REMOVE THE SHIFTING KEYS AND SPRINGS FROM FIFTH GEAR AND HUB SLEEVE NO.3**

Using a screwdriver, remove the three shifting keys and two rings.<sup>sp</sup>

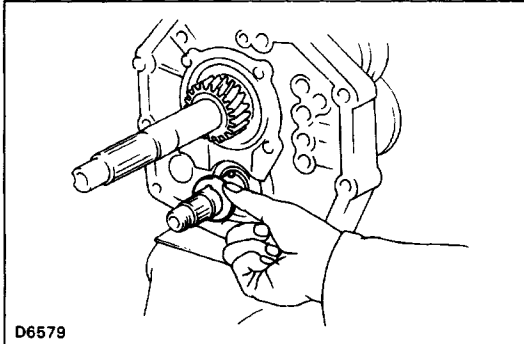
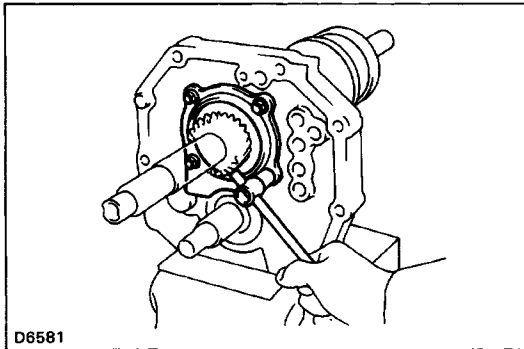
**28. REMOVE THRUST WASHER AND BALL****29. REMOVE REAR BEARING RETAINER**

Remove the four bolts and rear bearing retainer.

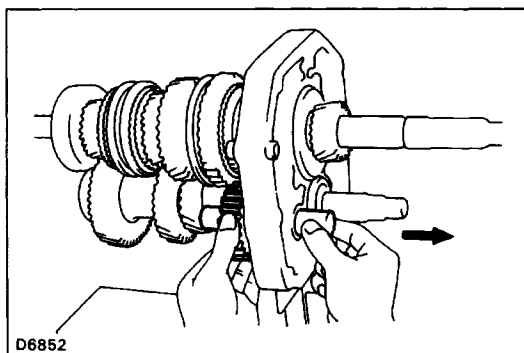
**30. REMOVE REVERSE IDLER GEAR AND SHAFT**

Pull out the shaft toward the rear.

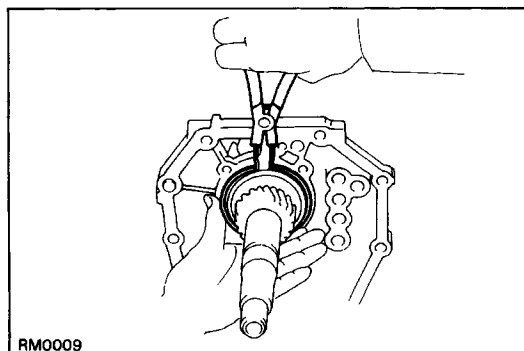
**31. REMOVE BEARING SNAP RING**

Using a snap ring expander, remove the snap ring.

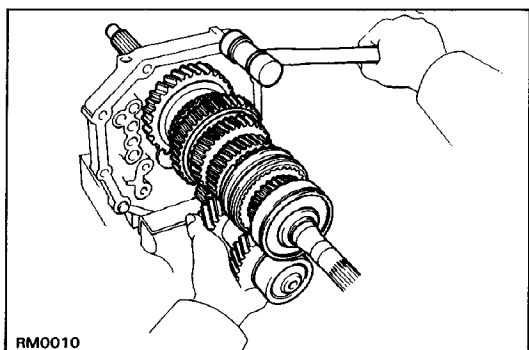

**32. REMOVE OUTPUT SHAFT, COUNTER GEAR AND INPUT SHAFT AS A UNIT FROM INTERMEDIATE PLATE**

- (a) Remove the output shaft, counter gear and input shaft as a unit from the intermediate plate by pulling on the counter gear and tapping on the intermediate plate with a plastic hammer.
- (b) Remove the input shaft with the needle roller bearing from the output shaft.

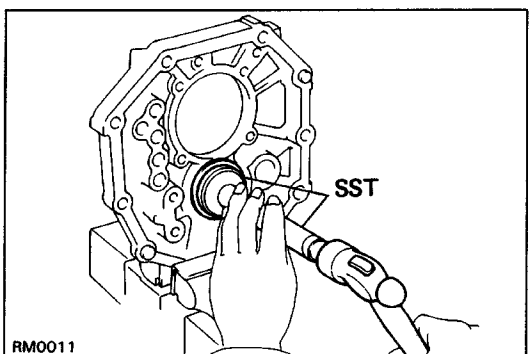

**33. REMOVE COUNTER REAR BEARING FROM INTERMEDIATE PLATE**

Using SST and a hammer, remove the counter rear bearing.

SST 09608-12010 (09608-00020, 09608-00050)

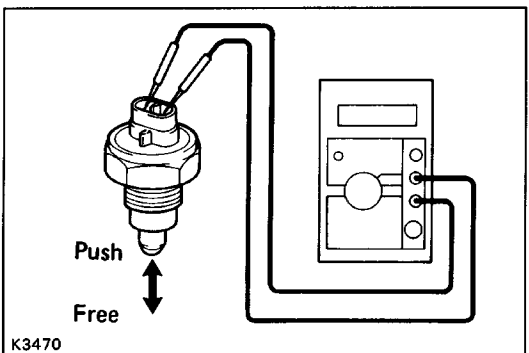

**34. INSPECT BACK-UP LIGHT SWITCH**

Check that there is continuity between terminals.

Switch Position	Specified
Push	Continuity
Free	No Continuity

If operation is not as specified replace switch.

## COMPONENT PARTS

### Input Shaft Assembly

## COMPONENTS

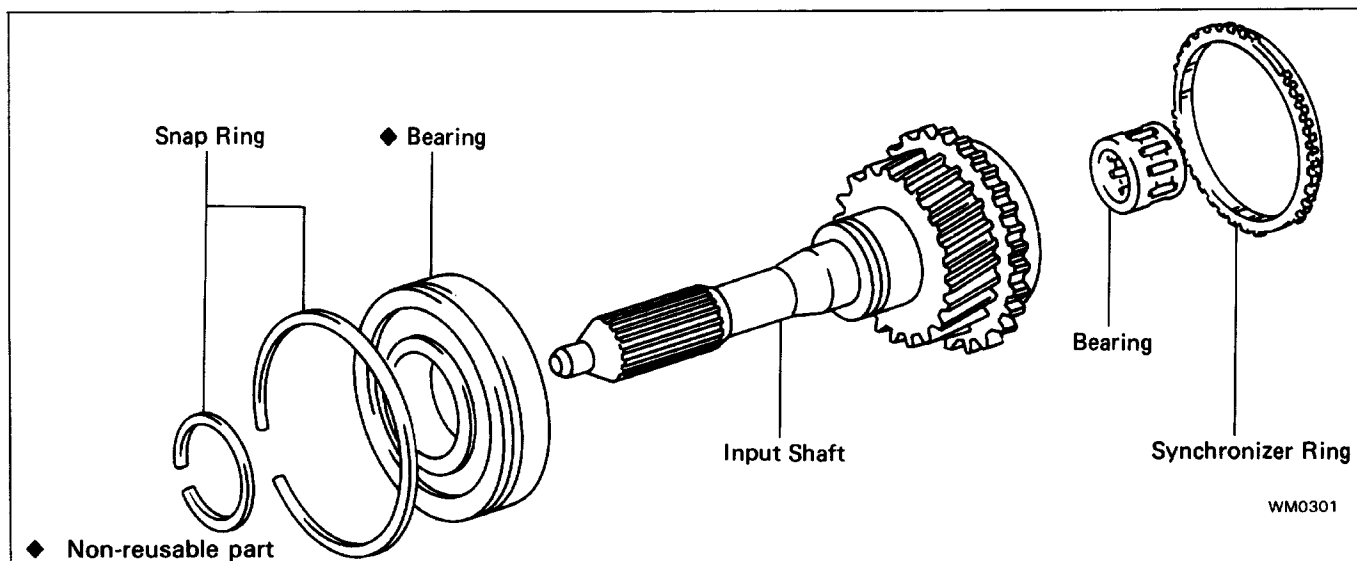

## INSPECTION OF INPUT SHAFT

### INSPECT SYNCHRONIZER RING

- (a) Turn the ring and push it in to check the breaking action.

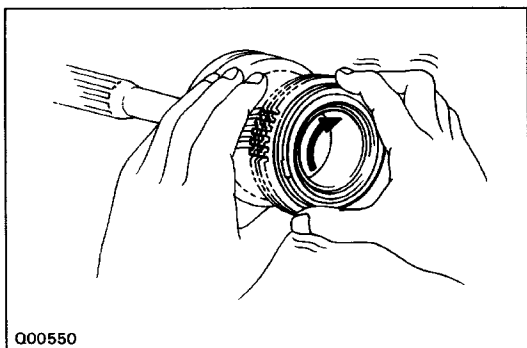

- (b) Using a feeler gauge, measure the clearance between the synchronizer ring back and the gear spline end.

**Standard clearance: 0.8 – 1.6 mm**  
(0.031 – 0.063 in.)

**Minimum clearance: 0.6 mm (0.024 in.)**

If the clearance is less than the minimum, replace the synchronizer ring.

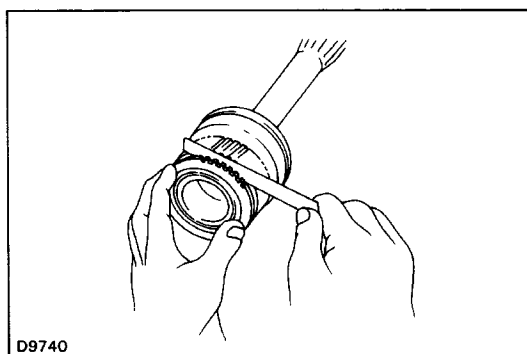

## REPLACEMENT OF BEARING

### IF NECESSARY, REPLACE INPUT SHAFT BEARING

- (a) Using snap ring pliers, remove the snap ring.

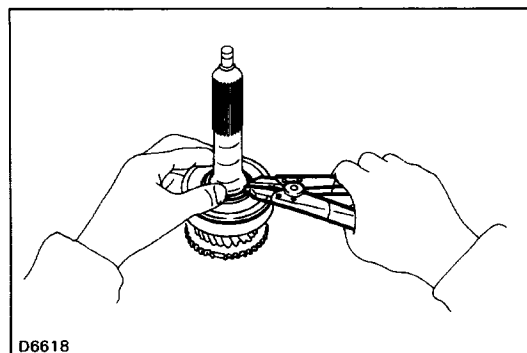

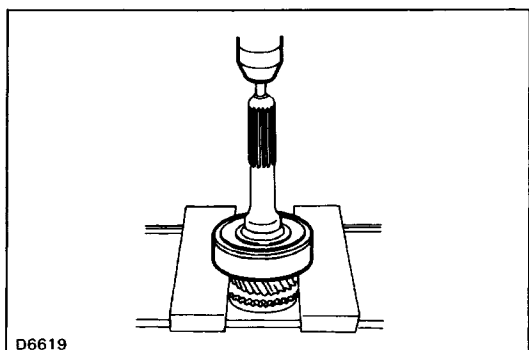

(b) Using a press, remove the bearing.

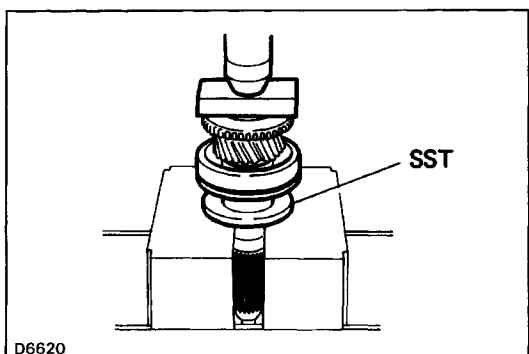

(c) Using SST and a press, install a new bearing.  
SST 09506-35010

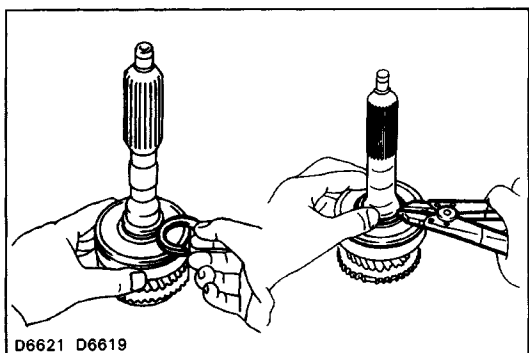

(d) Select a snap ring that will allow minimum axial play and install it on the shaft.

Mark	Thickness mm (in.)
A	2.10 – 2.15 (0.0827 – 0.0846)
B	2.15 – 2.20 (0.0846 – 0.0866)
C	2.20 – 2.25 (0.0866 – 0.0886)
D	2.25 – 2.30 (0.0886 – 0.0906)
E	2.30 – 2.35 (0.0906 – 0.0925)
F	2.35 – 2.40 (0.0925 – 0.0945)
G	2.40 – 2.45 (0.0945 – 0.0965)

# Output Shaft Assembly COMPONENTS

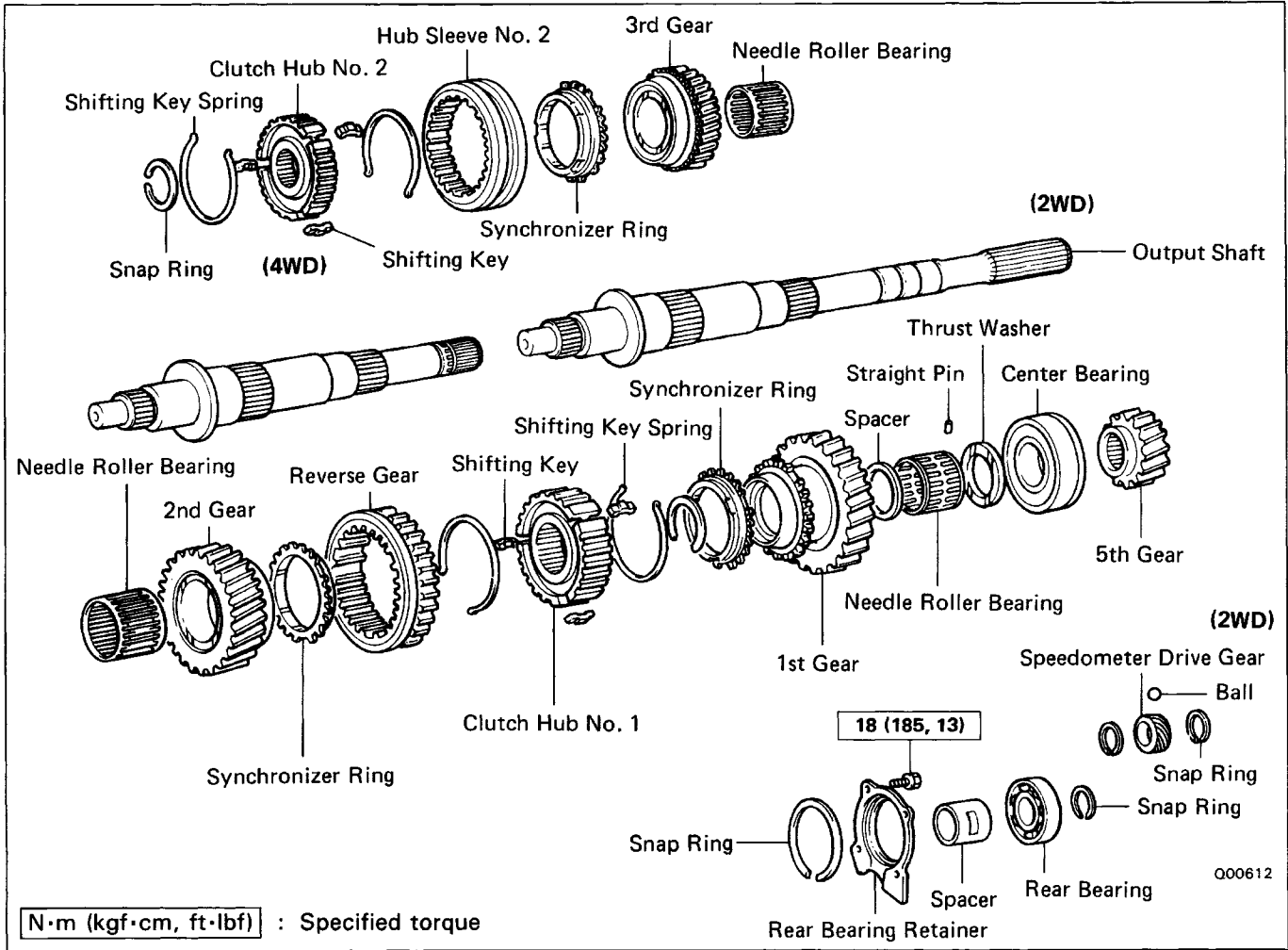

## DISASSEMBLY OF OUTPUT SHAFT ASSEMBLY

### 1. REMOVE FIFTH GEAR, CENTER BEARING AND FIRST GEAR ASSEMBLY

- (a) Using a press, remove the 5th gear, center bearing, thrust washer and 1st gear.
- (b) Remove the synchronizer ring.
- (c) Remove the straight pin and needle roller bearing.
- (d) Remove the spacer.

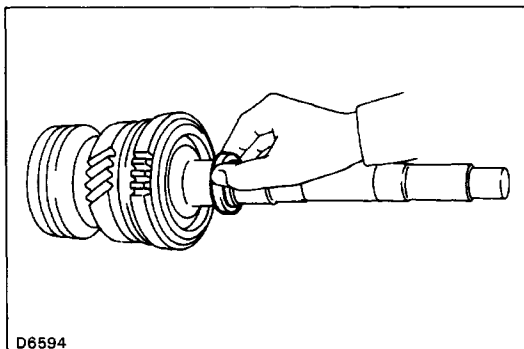
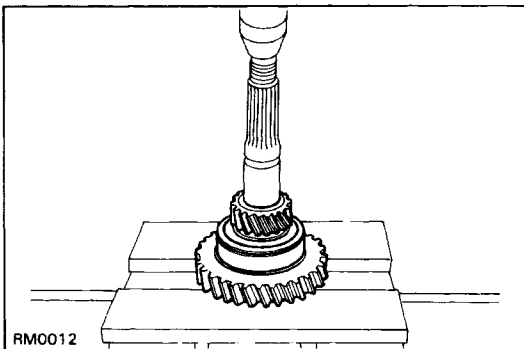

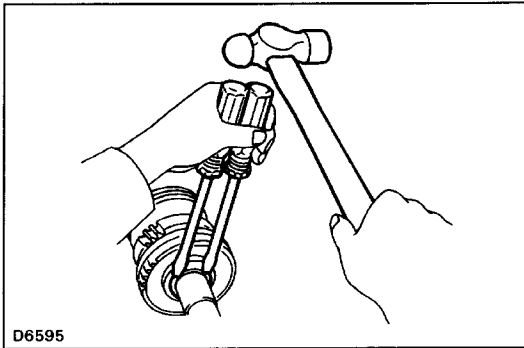

**2. REMOVE HUB SLEEVE NO.1 ASSEMBLY AND SECOND GEAR ASSEMBLY**

(a) Using two screwdrivers and a hammer, tap out the snap ring.

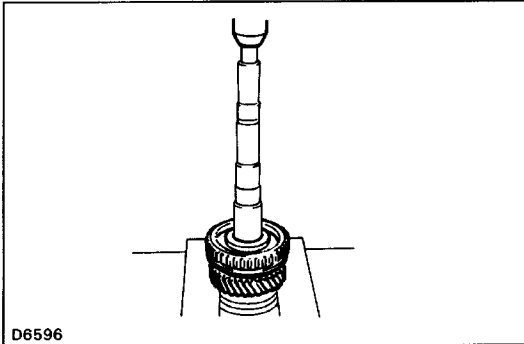

(b) Using a press, remove the hub sleeve No. 1, synchronizer ring and 2nd gear.

(c) Remove the needle roller bearing.

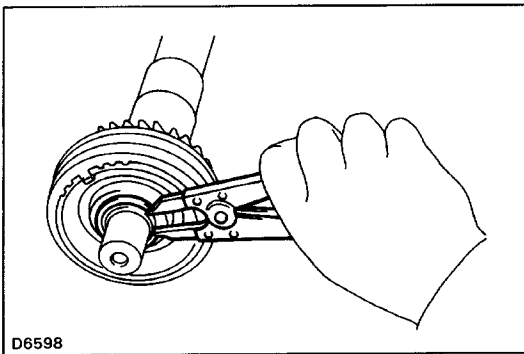

**3. REMOVE HUB SLEEVE NO.2 ASSEMBLY AND THIRD GEAR ASSEMBLY**

(a) Using a snap ring expander, remove the snap ring.

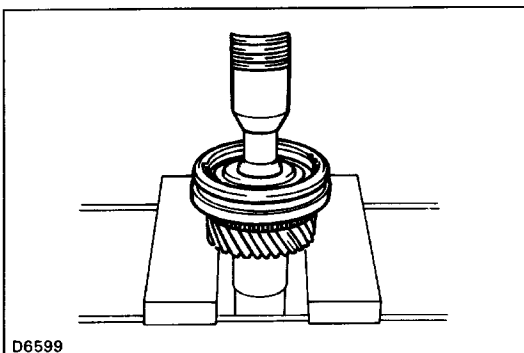

(b) Using a press, remove the hub sleeve No.2, synchronizer ring and 3rd gear.

(c) Remove the needle roller bearing.

**4. REMOVE THE SHIFTING KEYS AND SPRINGS FROM HUB SLEEVE ASSEMBLY**

Using screwdriver, remove the three shifting keys and two springs.

HINT: Hub sleeve No. 1 and hub sleeve No.2.

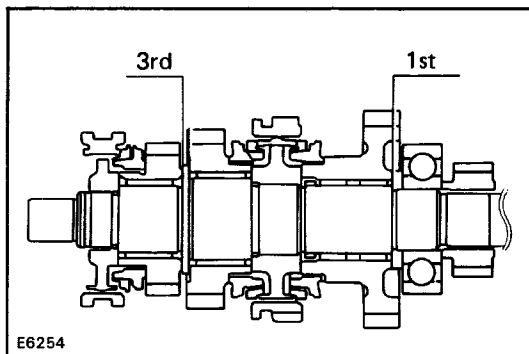

E6254

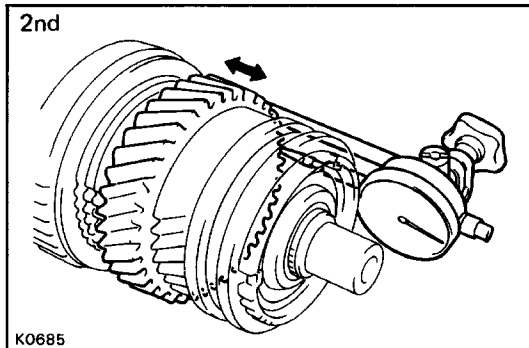

K0685

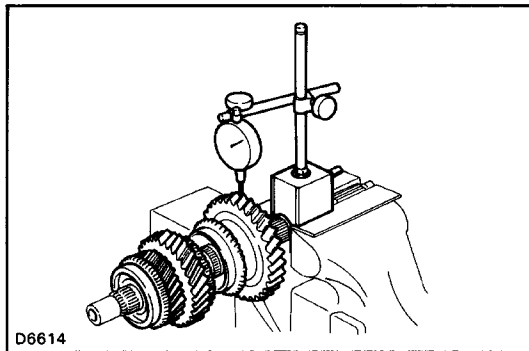

D6614

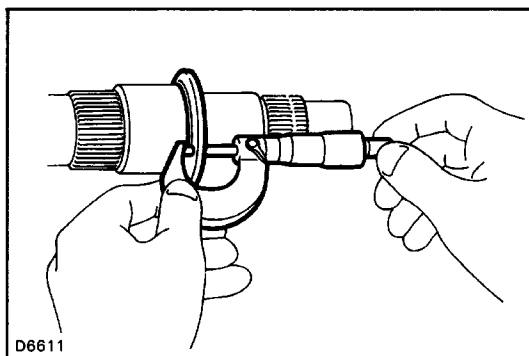

D6611

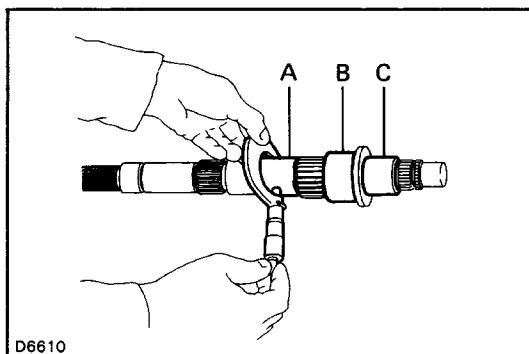

D6610

## INSPECT OF OUTPUT SHAFT ASSEMBLY

### 1. INSPECT EACH GEAR THRUST CLEARANCE

- Using a feeler gauge, measure the thrust clearance of 1st gear and 3rd gear.
- Using a dial indicator, measure the thrust clearance of 2nd gear.

#### 1st gear

**Standard clearance: 0.10 – 0.45 mm**  
(0.0039 – 0.0177 in.)

**Maximum clearance: 0.50 mm (0.0197 in.)**

#### 2nd and 3rd gears

**Standard clearance: 0.10 – 0.25 mm**  
(0.0039 – 0.0098 in.)

**Maximum clearance: 0.30 mm (0.0118 in.)**

### 2. INSPECT EACH GEAR OIL CLEARANCE

Using a dial indicator, measure the oil clearance between the gear and shaft with the needle roller bearing installed.

#### 1st gear

**Standard clearance: 0.020 – 0.073 mm**  
(0.0008 – 0.0029 in.)

**Maximum clearance: 0.16 mm (0.0063 in.)**

#### 2nd and 3rd gears

**Standard clearance: 0.015 – 0.068 mm**  
(0.0006 – 0.0027 in.)

**Maximum clearance: 0.16 mm (0.0063 in.)**

If the clearance exceeds the maximum, replace the gear needle roller bearing or shaft.

### 3. INSPECT OUTPUT SHAFT

- Using a micrometer, measure the output shaft flange thickness.

**Minimum thickness: 4.70 mm (0.1850 in.)**

If the thickness exceeds the minimum, replace the output shaft.

- Using a micrometer, measure the outer diameter of the output shaft journal.

**Minimum diameter:**

**(A) 1st gear 38.860 mm (1.5299 in.)**

**(B) 2nd gear 46.860 mm (1.8449 in.)**

**(C) 3rd gear 37.860 mm (1.4905 in.)**

If the outer diameter exceeds the minimum, replace the output shaft.



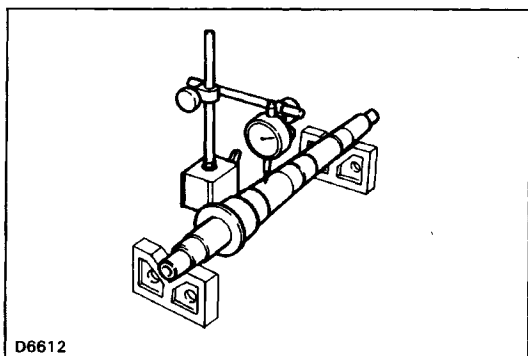

D6612

(c) Using a dial indicator, check the shaft runout.

**Maximum runout: 0.06 mm (0.0024 in.)**

If the runout exceeds the maximum, replace the output shaft.

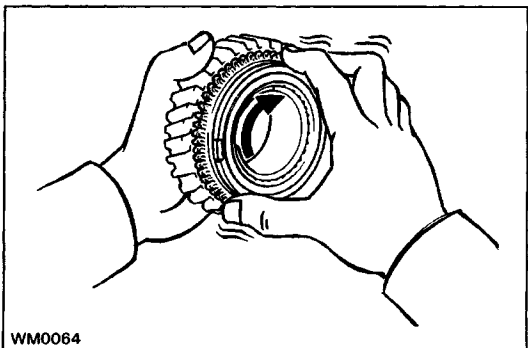

WM0064

#### 4. INSPECT SYNCHRONIZER RINGS

(a) Turn the ring and push it in to check the braking action.

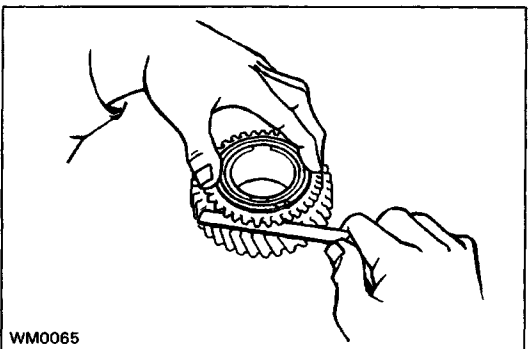

WM0065

(b) Using a feeler gauge, measure the clearance between the synchronizer ring back and the gear spline end.

**Standard clearance: 0.8 – 1.6 mm  
(0.031 – 0.063 in.)**

**Minimum clearance: 0.6 mm (0.024 in.)**

If the clearance is less than the minimum, replace the synchronizer ring.

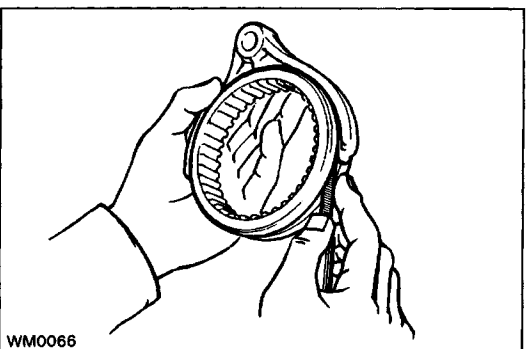

WM0066

#### 5. INSPECT CLEARANCE OF SHIFT FORKS AND HUB SLEEVES

Using a feeler gauge, measure the clearance between the hub sleeve and shift fork.

**Maximum clearance: 1.0 mm (0.039 in.)**

If the clearance exceeds the maximum, replace the shift fork or hub sleeve.

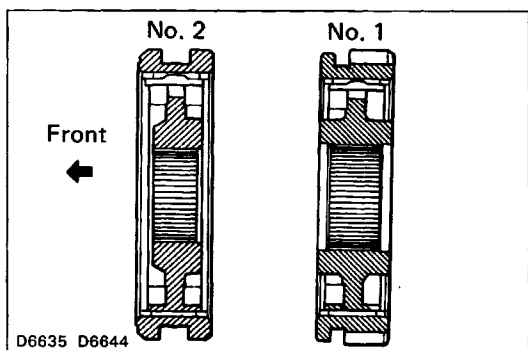

## ASSEMBLY OF OUTPUT SHAFT ASSEMBLY

### 1. INSERT CLUTCH HUB NO. 1 AND NO.2 INTO HUB SLEEVE

- (a) Install the clutch hub and shifting keys to the hub sleeve.
- (b) Install the shifting key springs under the shifting keys.

**NOTICE:** Install the key springs positioned so that their end gaps are not in 1 if .

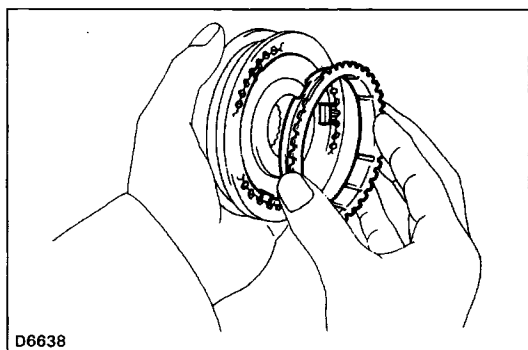

### 2. INSTALL THIRD GEAR AND HUB SLEEVE NO.2 ON OUTPUT SHAFT

- (a) Apply gear oil to the shaft and needle roller bearing.
- (b) Place the synchronizer ring on the gear and align the ring slots with the shifting keys.
- (c) Install the needle roller bearing in the 3rd gear.

- (d) Using a press, install the 3rd gear and No.2 hub sleeve.

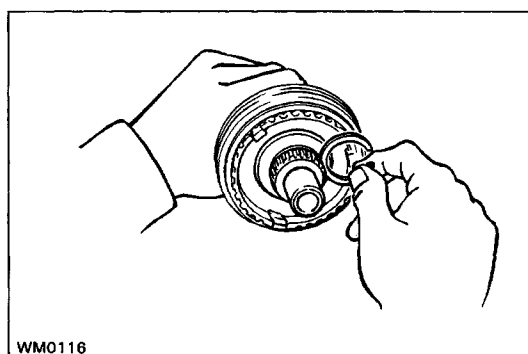
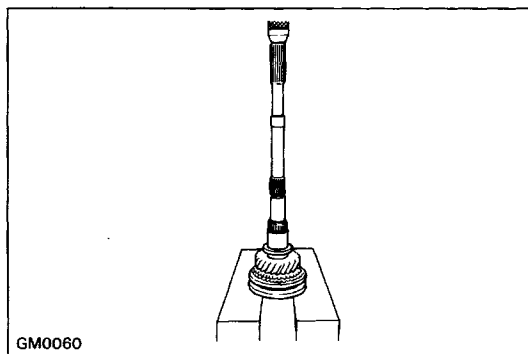

### 3. INSTALL SNAP RING

- (a) Select a snap ring that will allow minimum axial play.

Mark	Thickness mm (in.)
A	1.80 - 1.85 (0.0709 - 0.0728)
B	1.85 - 1.90 (0.0728 - 0.0748)
C	1.90 - 1.95 (0.0748 - 0.0768)
D	1.95 - 2.00 (0.0768 - 0.0787)
E	2.00 - 2.05 (0.0787 - 0.0807)
F	2.05 - 2.10 (0.0807 - 0.0827)
G	2.10 - 2.15 (0.0827 - 0.0846)

- (b) Using snap ring pliers, install the snap ring.

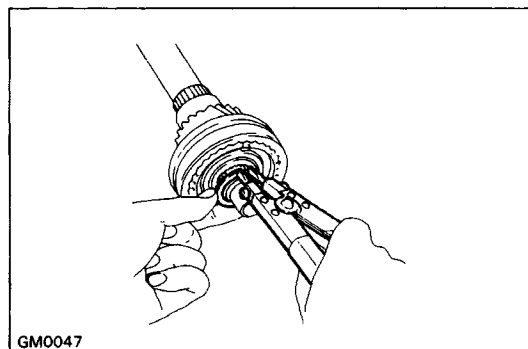

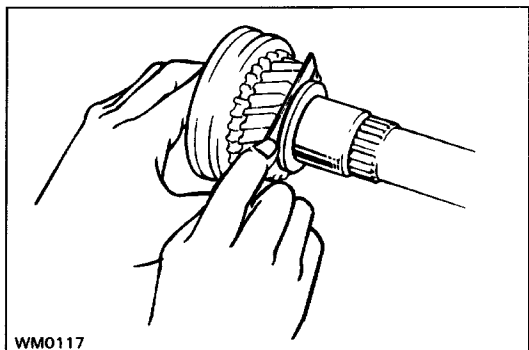

#### 4. INSPECT THIRD GEAR THRUST CLEARANCE

Using a feeler gauge, measure the 3rd gear thrust clearance.

**Standard clearance: 0.10 – 0.25 mm  
(0.0039 – 0.0098 in.)**

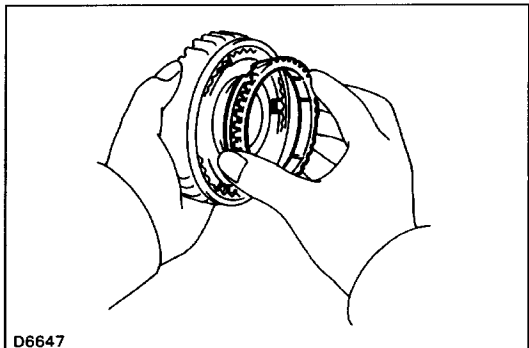

#### 5. INSTALL SECOND GEAR AND HUB SLEEVE NO. 1

- Apply gear oil to the shaft and needle roller bearing.
- Place the synchronizer ring on the gear and align the ring slots with the shifting keys.
- Install the needle roller bearing in the 2nd gear.

- Using a press, install the 2nd gear and hub sleeve No. 1.

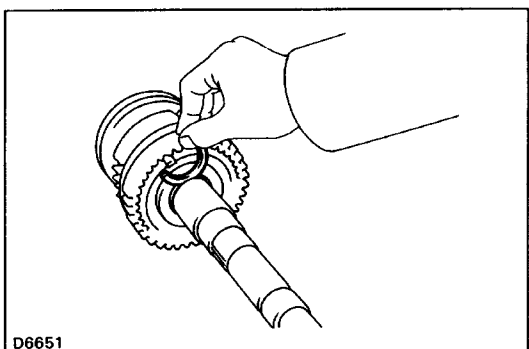
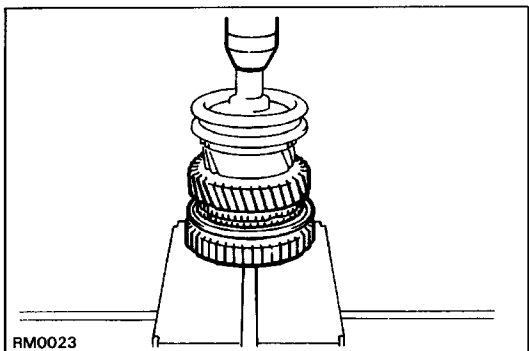

#### 6. INSTALL SNAP RING

- Select a snap ring that will allow minimum axial play.

Mark	Thickness mm (in.)
A	2.30 – 2.35 (0.0906 – 0.0925)
B	2.35 – 2.40 (0.0925 – 0.0945)
C	2.40 – 2.45 (0.0945 – 0.0965)
D	2.45 – 2.50 (0.0965 – 0.0984)
E	2.50 – 2.55 (0.0984 – 0.1004)
F	2.55 – 2.60 (0.1004 – 0.1024)
G	2.60 – 2.65 (0.1024 – 0.1043)

- Using a screwdriver and hammer, install the snap ring.

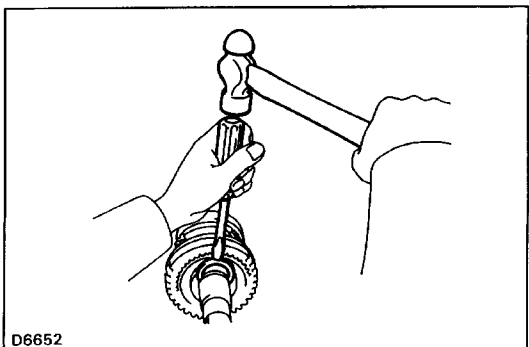

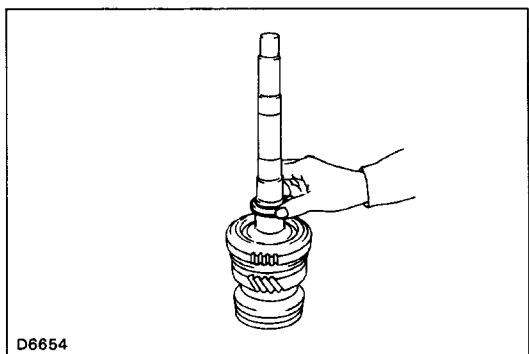

D6654

## 7. INSTALL SPACER AND FIRST GEAR ASSEMBLY

- (a) Install the spacer on the output shaft.

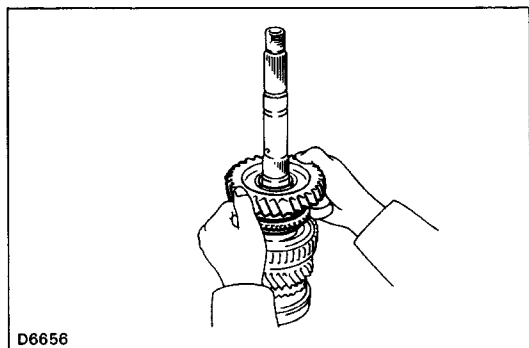

D6656

- (b) Apply gear oil to the needle roller bearing.  
 (c) Assemble the 1st gear, synchronizer ring and needle roller bearing.  
 (d) Install the assembly on the output shaft with the synchronizer ring slots aligned with the shifting keys.

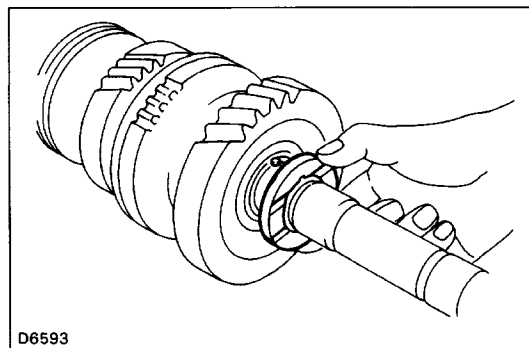

D6593

## 8. INSTALL STRAIGHT PIN AND FIRST GEAR THRUST WASHER

Install the 1st gear thrust washer onto the output shaft with the straight pin aligned with the 1st gear thrust washer.

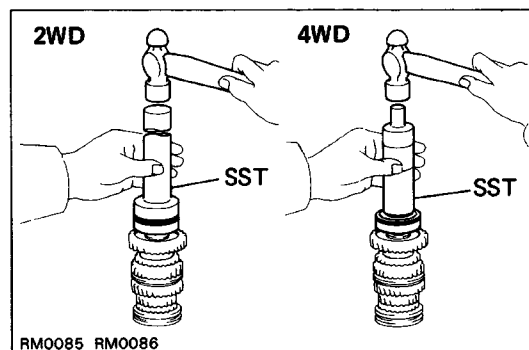

RMO085 RMO086

## 9. INSTALL OUTPUT SHAFT CENTER BEARING

Using SST and a hammer, drive in the bearing with the outer race snap ring groove toward the rear.

SST (2WD) 09309-35010

(4WD) 09316-60010

(09316-00010, 09316-00070)

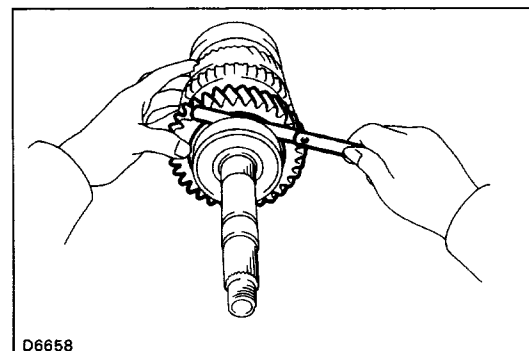

D6658

## 10. INSPECT FIRST GEAR THRUST CLEARANCE

Using a feeler gauge, measure the 1st clearance.

**Standard clearance:**

**1st gear 0.10 – 0.45 mm (0.0039 – 0.0177 in.)**

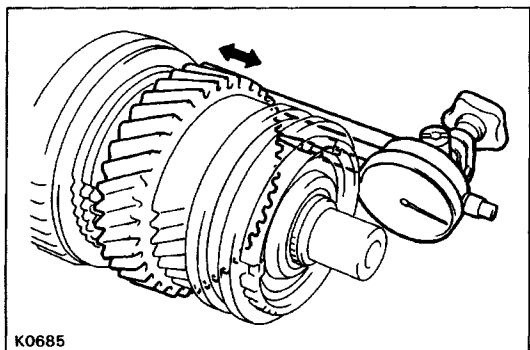

### 11. INSPECT SECOND GEAR THRUST CLEARANCE

Using a dial indicator, measure the 2nd gear thrust clearance.

**Standard clearance:**

**2nd gear 0.10 – 0.25 mm (0.0039 – 0.0098 in. )**

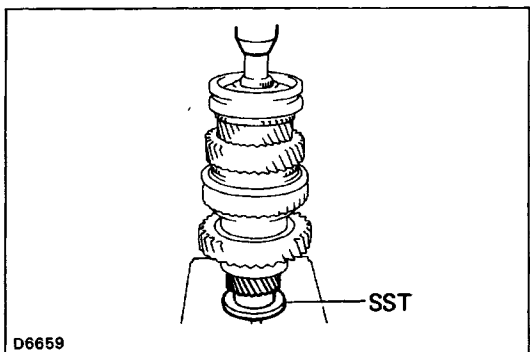

### 12. INSTALL FIFTH GEAR

Using SST and a press, install the 5th gear.

SST 09316-60010 (09316-00030)

# Counter Gear Assembly and Reverse Idler Gear COMPONENTS

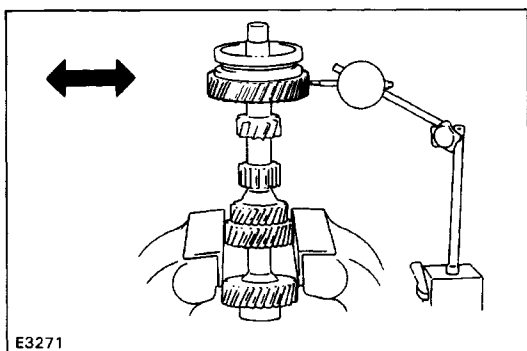
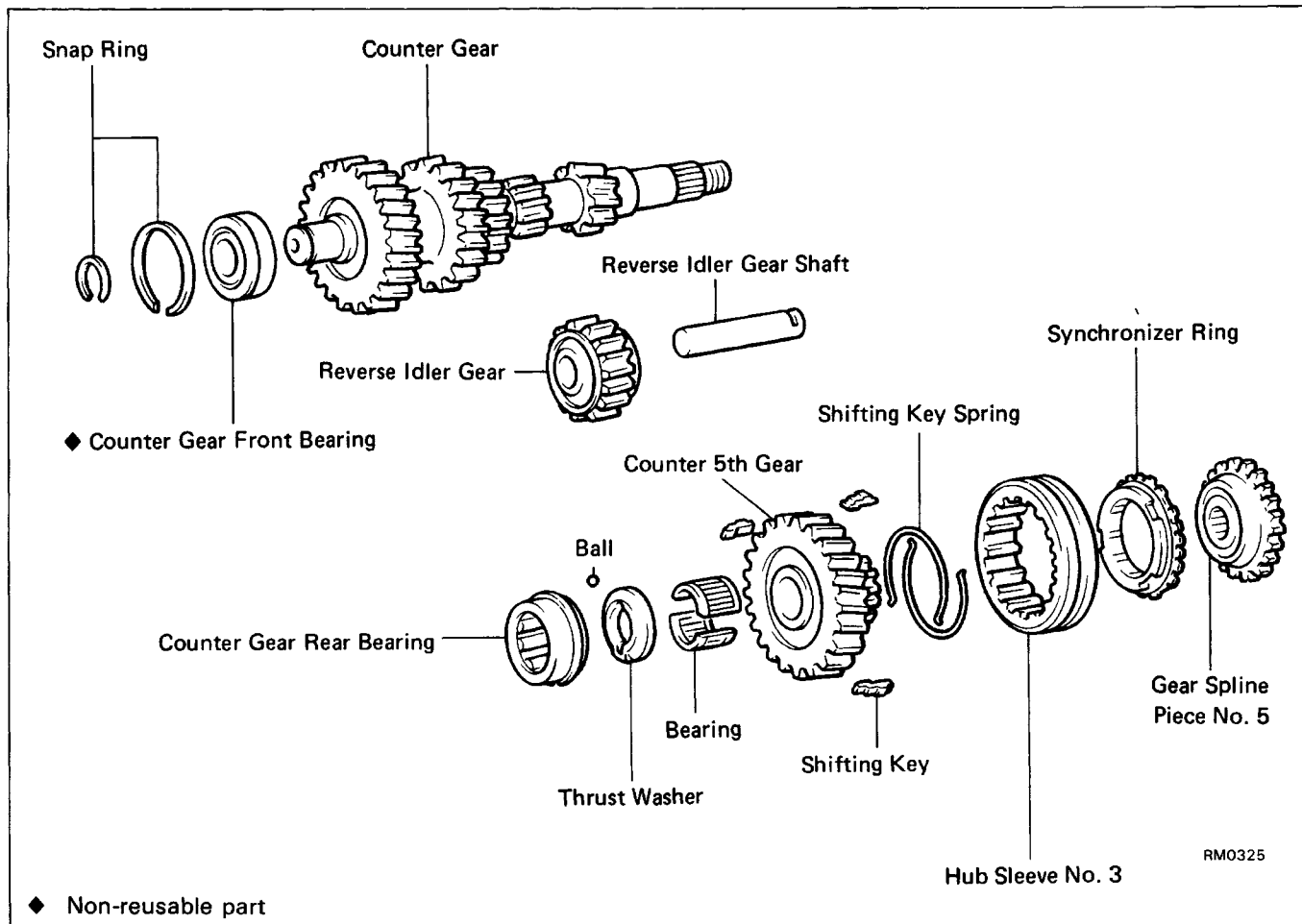

## INSPECTION OF COUNTER GEAR

### 1. INSPECT FIFTH GEAR OIL CLEARANCE

- Install the spacer, counter 5th gear and needle roller bearings.
- Using a dial indicator, measure the counter 5th gear oil clearance.

**Standard clearance: 0.015 – 0.068 mm**  
(0.006 – 0.0027 in.)

**Maximum clearance: 0.16 mm (0.0063 in.)**

If the clearance exceeds the maximum, replace the gear bearing or shaft.

### 2. REMOVE HUB SLEEVE NO.3, SHIFTING KEYS AND SPRINGS FROM COUNTER FIFTH GEAR.

Using a screwdriver, remove the three shifting keys and two springs from counter 5th gear.

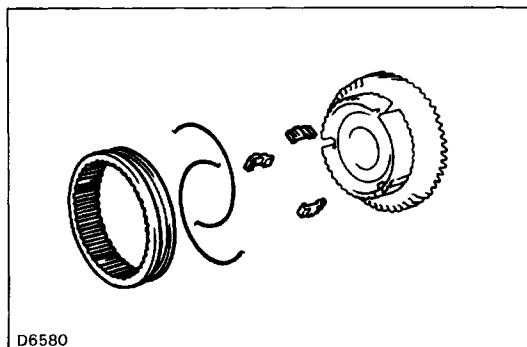

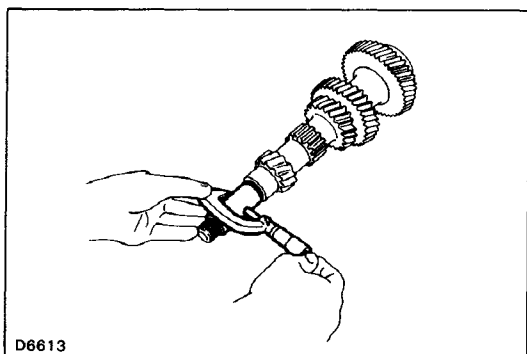

### 3. INSPECT COUNTER GEAR

Using a micrometer, measure the outer diameter of the counter gear journal.

**Minimum diameter: 27.860 mm (1.0968 in.)**

If the outer diameter exceeds the minimum, replace the counter gear.

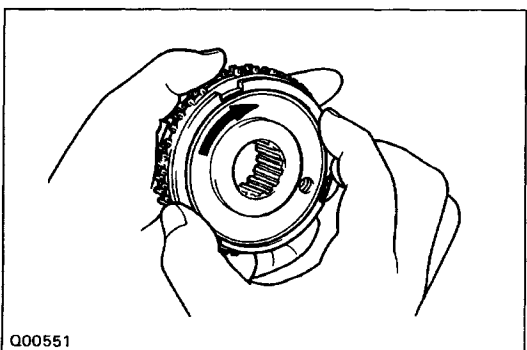

### 4. INSPECT SYNCHRONIZER RINGS

(a) Turn the ring and push it in to check the braking action.

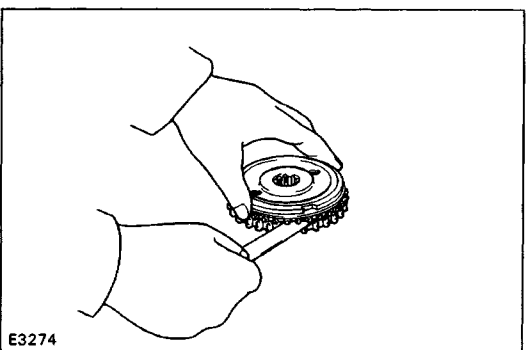

(b) Using a feeler gauge, measure the clearance between the synchronizer ring back and the gear spline end.

**Standard clearance: 0.8 – 1.6 mm**

**(0.031 – 0.063 in.)**

**Minimum clearance: 0.6 mm (0.024 in.)**

If the clearance is less than the minimum, replace the synchronizer ring.

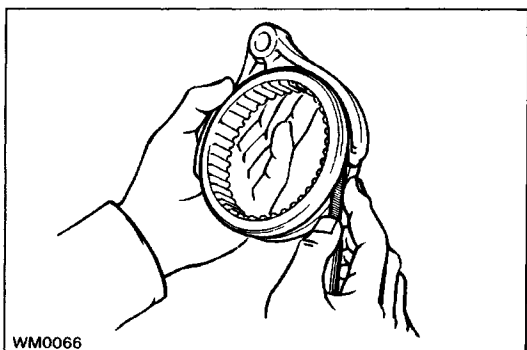

### 5. INSPECT CLEARANCE OF SHIFT FORKS AND HUB SLEEVES

Using a feeler-gauge, measure the clearance between the hub sleeve and shift fork.

**Maximum clearance: 1.0 mm (0.039 in.)**

If the clearance exceeds the maximum, replace the shift fork or hub sleeve.

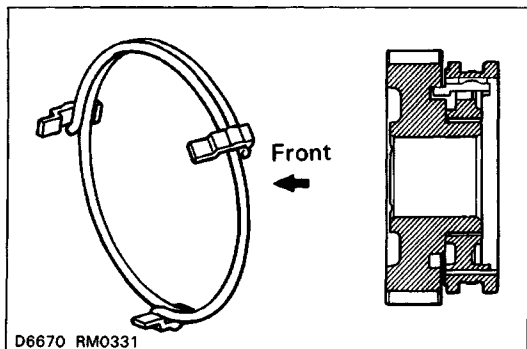

### 6. INSTALL HUB SLEEVE NO.3, SHIFTING KEYS AND SPRINGS TO COUNTER 5TH GEAR

(a) Install the counter 5th gear and shifting keys to the hub sleeve.

(b) Install the shifting key springs under the shifting keys.

**NOTICE:** Install the key springs positioned so that their end gaps are not in line.

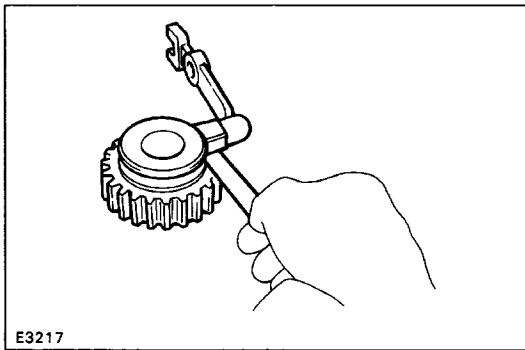

## INSPECTION OF REVERSE IDLER GEAR

### 1. INSPECT CLEARANCE OF REVERSE IDLER GEAR AND SHIFT ARM SHOE

Using a feeler gauge, measure the clearance between the reverse idler gear and shift arm shoe.

**Standard clearance: 0.05 – 0.25 mm**  
(0.0020 – 0.098 in.)

**Maximum clearance: 0.5 mm (0.0197 in.)**

If the clearance exceeds the maximum, replace the shift arm shoe or reverse idler gear.

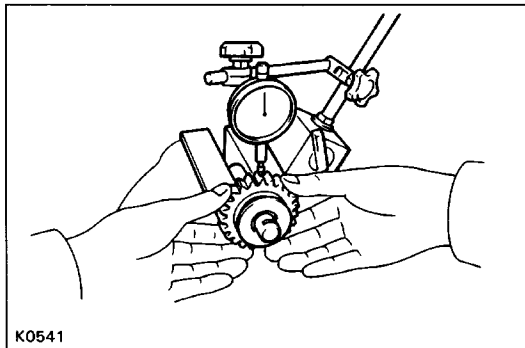

### 2. INSPECT REVERSE IDLER GEAR OIL CLEARANCE

Using a dial indicator, measure the reverse idler gear oil clearance.

**Standard clearance: 0.040 – 0.082 mm**  
(0.0016 – 0.032 in.)

**Maximum clearance: 0.13 mm (0.0051 in.)**

If the clearance exceeds the maximum, replace the reverse idler gear or reverse idler gear shaft.

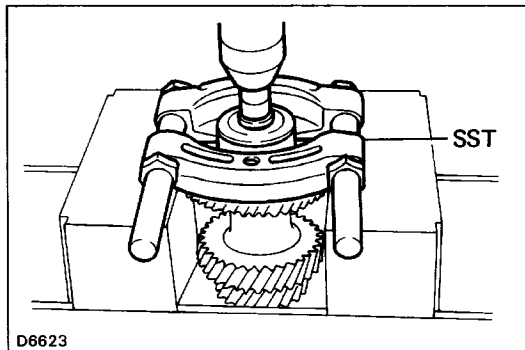

## REPLACEMENT OF BEARING

### IF NECESSARY, REPLACE COUNTER GEAR FRONT BEARING

- (a) Using a snap ring expander, remove the snap ring.
- (b) Using SST and a press, remove the bearing.  
SST 09950-00020
- (c) Replace the side race.

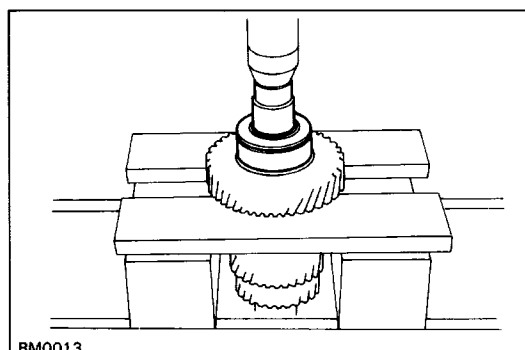

- (d) Using a 24 mm socket wrench, press in the bearing and inner race.

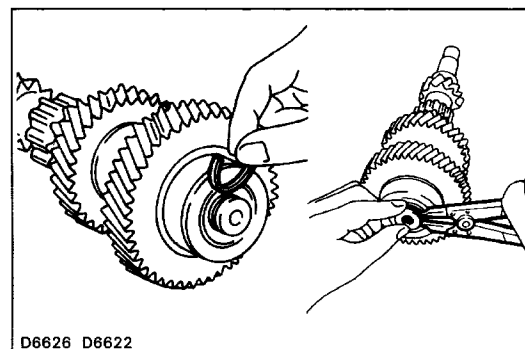

- (e) Select a snap ring that will allow minimum axial play and install it on the shaft.

Mark	Thickness mm (in.)
A	2.00 – 2.05 (0.0787 – 0.0807)
B	2.05 – 2.10 (0.0807 – 0.0827)
C	2.10 – 2.15 (0.0827 – 0.0846)
D	2.15 – 2.20 (0.0846 – 0.0866)
E	2.20 – 2.25 (0.0866 – 0.0886)



# Extension Housing and Transfer Adaptor COMPONENTS

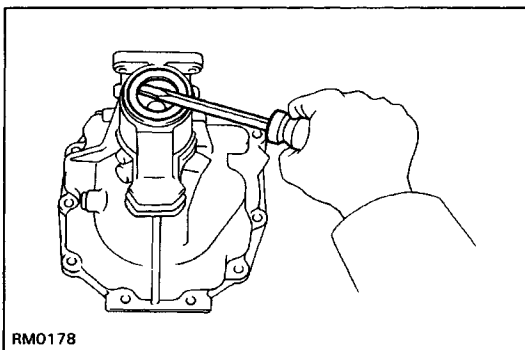
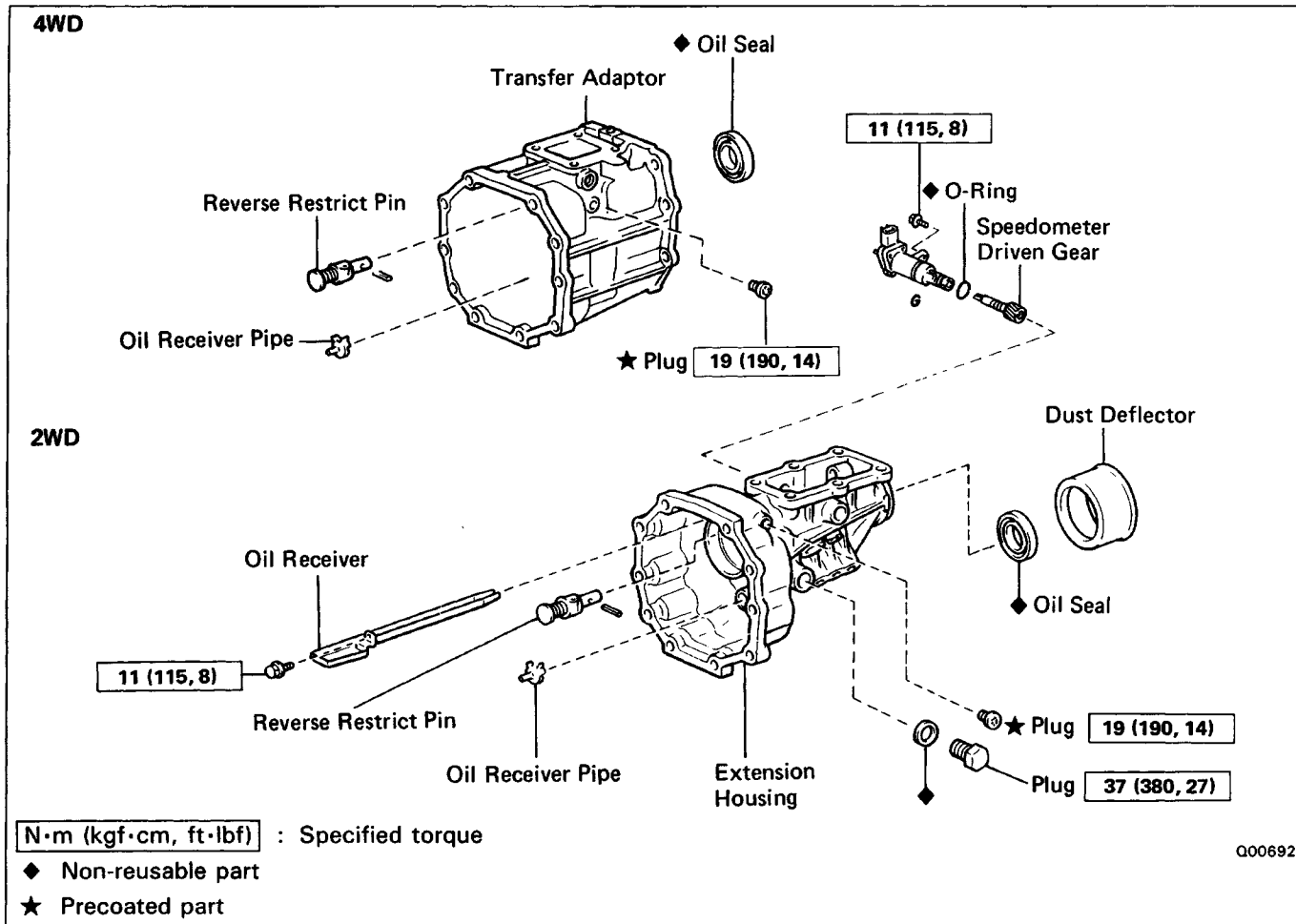

## REPLACEMENT OF OIL SEAL

### 1. (2WD)

#### IF NECESSARY, REPLACE EXTENSION HOUSING OIL SEAL

- Remove the dust deflector.
- Using a screwdriver, pry out the oil seal.

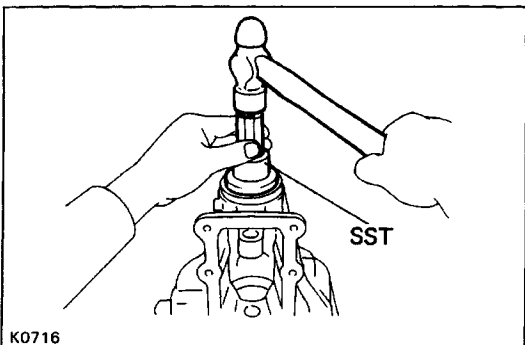

- Using SST and a hammer, drive in a new oil seal.  
SST 0932 5-40010
- Install the dust deflector.

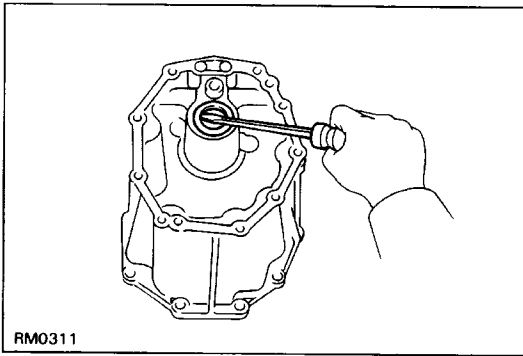

**2. (4WD)  
IF NECESSARY, REPLACE TRANSFER ADAPTOR OIL SEAL**

(a) Using a screwdriver, pry out the oil seal.

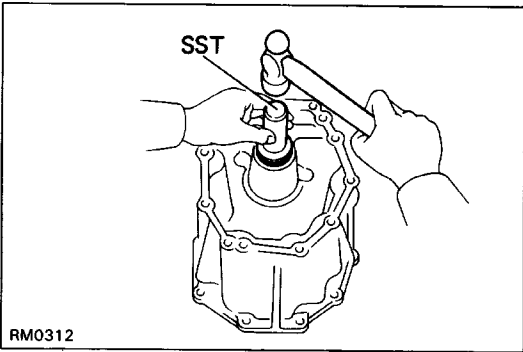

(b) Using SST and a hammer, drive in a new oil seal.  
SST 09325-12010

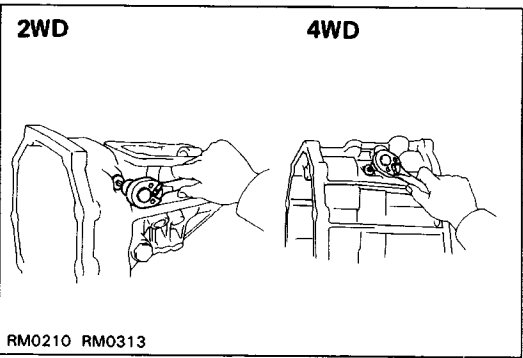

**INSPECTION AND REPLACEMENT OF REVERSE RESTRICT PIN**

**1. REMOVE THE REVERSE RESTRICT PIN**

(a) Using a torx socket wrench, remove the screw plug.  
(Torx socket wrench T40 09042-00020)

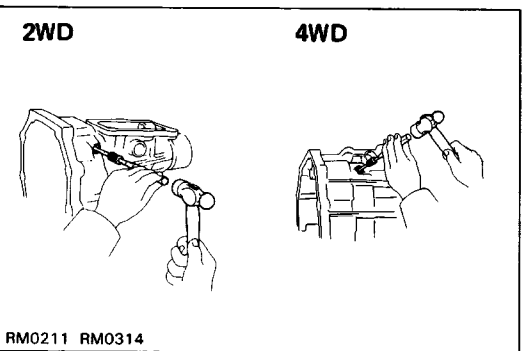

(b) Using a pin punch and hammer, drive out the slotted spring pin.

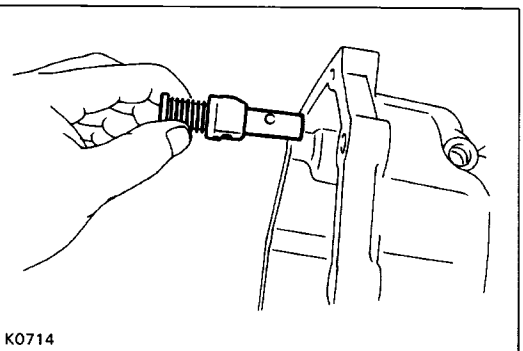

(c) Remove the reverse restrict pin.

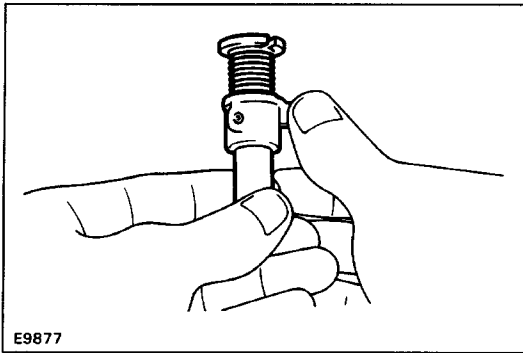

## 2. INSPECTION OF REVERSE RESTRICT PIN

Turn and push the reverse restrict pin by hand while applying force in axial direction.

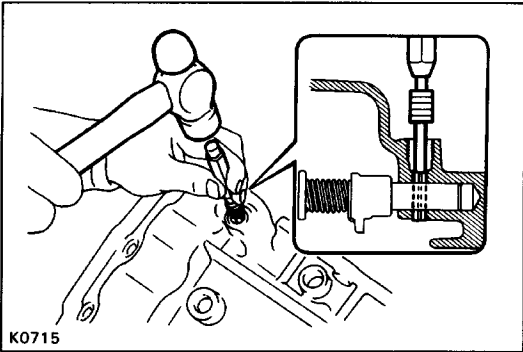

## 3. INSTALL THE REVERSE RESTRICT PIN

- (a) Install the reverse restrict pin to the extension housing or transfer adaptor.
- (b) Using a pin punch and hammer, drive in the slotted spring pin as shown.

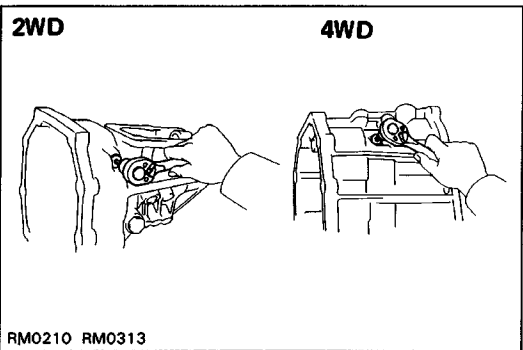

- (c) Apply liquid sealer to the plug threads.  
**Sealant: Part No. 08833-00080, THREE BOND 1344, LOCTITE 242 or equivalent**
- (d) Using a torx socket wrench, install and torque the screw plug.  
(Torx socket wrench T40 09042-00020)  
**Torque: 19 N-m (190 kgf -cm, 14 ft -lbf)**

## Front Bearing Retainer COMPONENTS

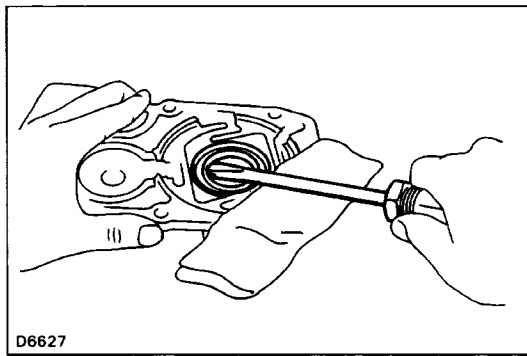
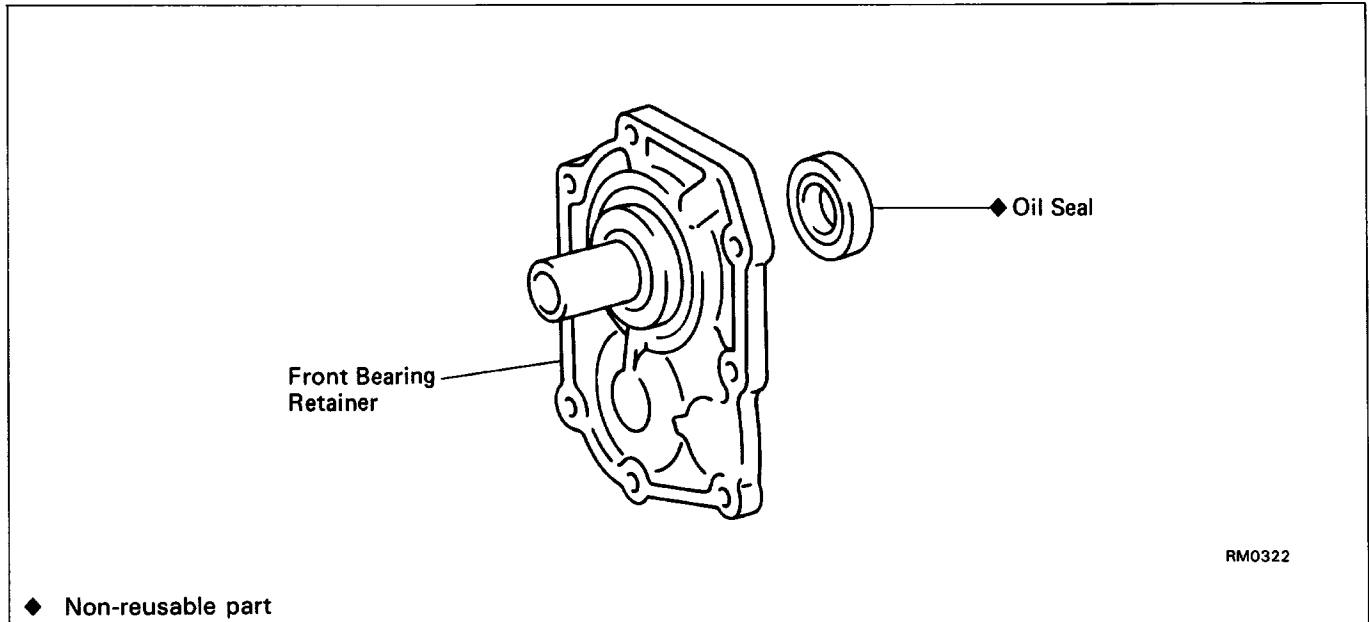

### REPLACEMENT OF OIL SEAL IF NECESSARY, REPLACE FRONT BEARING RETAINER OIL SEAL

(a) Using a screwdriver, pry out the oil seal.

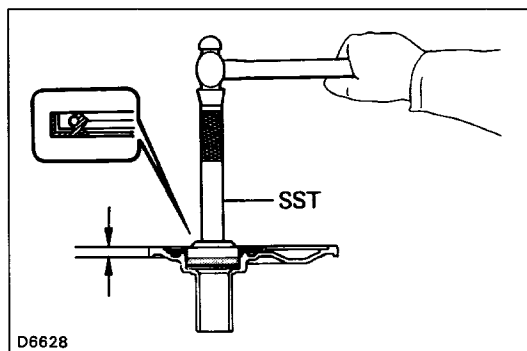

(b) Using SST and a hammer, drive in a new oil seal.  
SST 09608-35014 (09608-06020, 09608-06090)

**Drive in depth: 11.2 - 12.2 mm (0.441 - 0.480 in.)**  
**Transmission case installation surface**

## ASSEMBLY OF TRANSMISSION

(See pages [MT1-67](#), [68](#))

### 1. INSTALL OUTPUT SHAFT TO INTERMEDIATE PLATE

- (a) Install the output shaft into the intermediate plate by pushing on the output shaft and tapping on the intermediate plate.

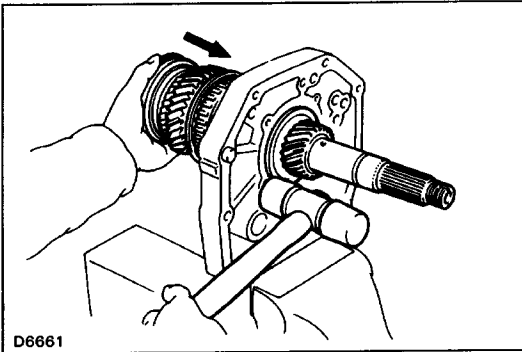

- (b) Using snap ring pliers, install the snap ring.

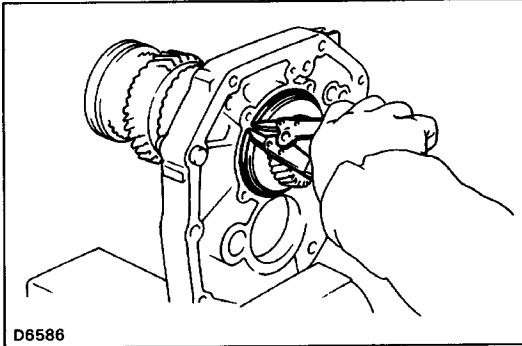

### 2. INSTALL INPUT SHAFT

- (a) Apply gear oil to the needle roller bearing and install it into the input shaft.
- (b) Install the input shaft to the output shaft with the synchronizer ring slots aligned with the shifting keys.

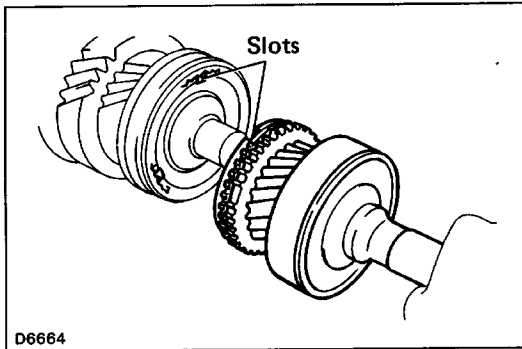

### 3. INSTALL COUNTER GEAR

Install the counter gear into the intermediate plate while holding the counter gear, and install the counter rear bearing with a plastic hammer.

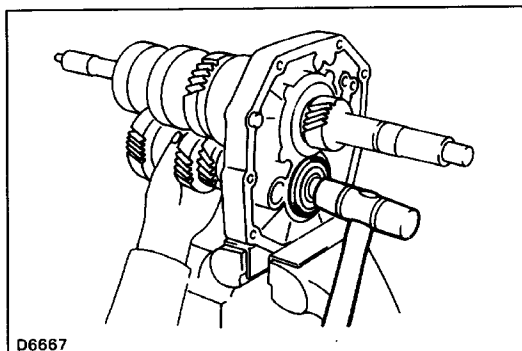

### 4. INSTALL REVERSE SHIFT ARM BRACKET

Install the reverse shift arm bracket and torque the bolts.

**Torque: 18 N-m (185 kgf-cm, 13 ft-lbf)**

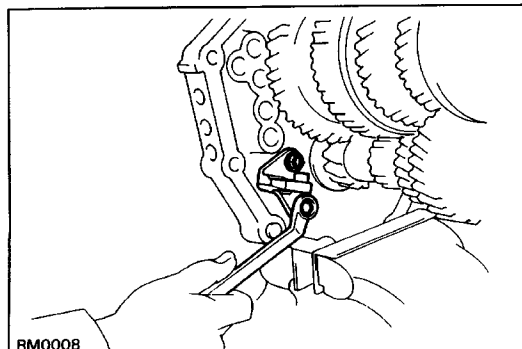

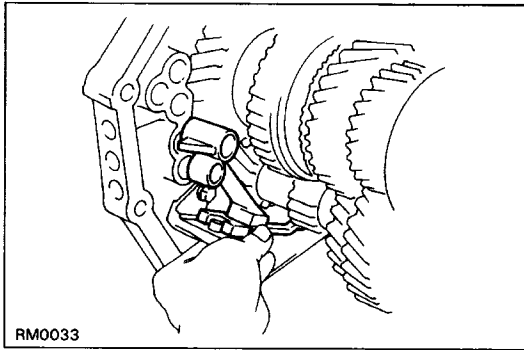

RM0033

### 5. INSTALL REVERSE SHIFT ARM TO REVERSE SHIFT ARM BRACKET

Install the reverse shift arm to the pivot of the reverse shift arm bracket.

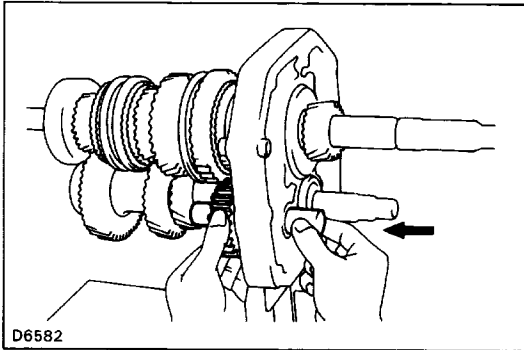

D6582

### 6. INSTALL REVERSE IDLER GEAR AND SHAFT

Align the reverse shift arm shoe to the reverse idler gear groove and insert the reverse idler gear shaft to the intermediate plate.

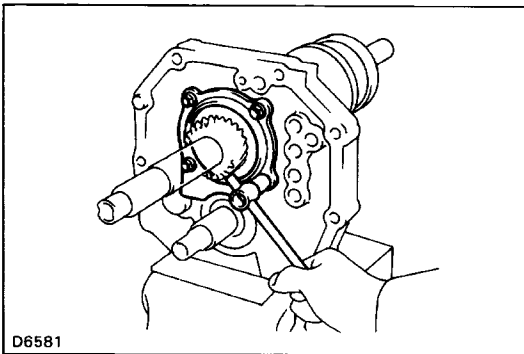

D6581

### 7. INSTALL REAR BEARING RETAINER

- (a) Align the rear bearing retainer to the reverse idler gear shaft groove.
- (b) Install and torque the bolts.

**Torque: 18 N-m (185 kgf-cm, 13 ft-lbf)**

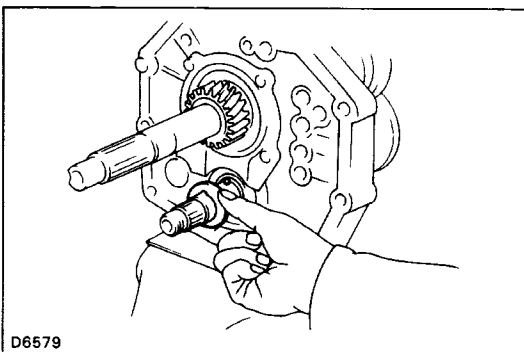

D6579

### 8. INSTALL BALL AND THRUST WASHER

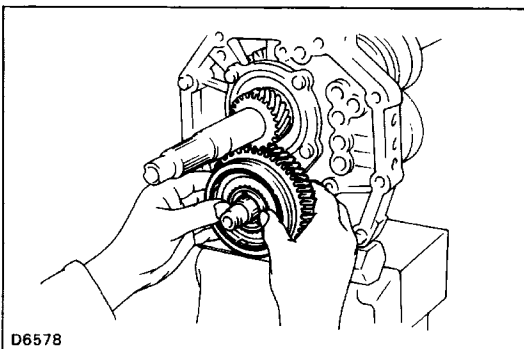

D6578

### 9. INSTALL COUNTER FIFTH GEAR WITH NO.3 HUB SLEEVE ASSEMBLY AND NEEDLE ROLLER BEARINGS

- (a) Apply gear oil to the needle roller bearings.
- (b) Install the counter 5th gear with No.3 hub sleeve and needle roller bearings.

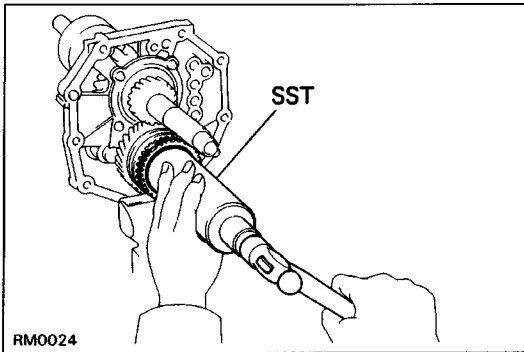

**10. INSTALL SYNCHRONIZER RING AND GEAR SPLINE PIECE NO.5**

- (a) Install the synchronizer ring on gear spline piece No. 5.
- (b) Using SST and a hammer, drive in gear spline piece No. 5 with the synchronizer ring slots aligned with the shifting keys.

SST 09316-60010 (09316-00010)

**HINT:** When installing gear spline piece No.5, support the counter gear in front with a 3-5 lb hammer or equivalent.

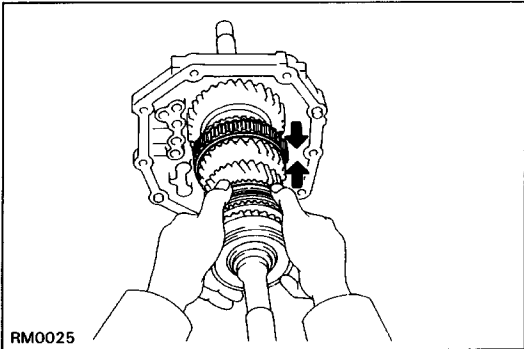

**11. INSTALL LOCK NUT**

- (a) Engage the gear double meshing.

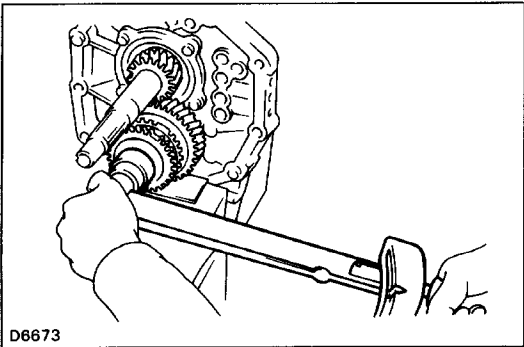

- (b) Install and torque the lock nut.

**Torque: 127 N-m (1, 300 kgf-cm, 94 ft-lbf )**

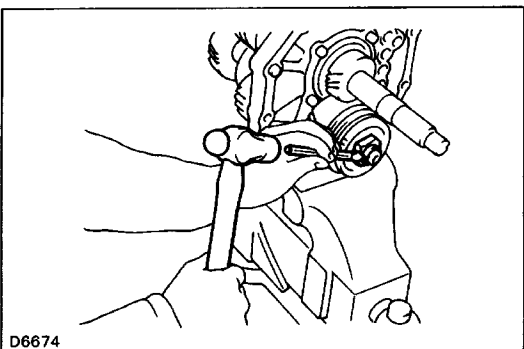

- (c) Stake the lock nut.

- (d) Disengage the gear double meshing.

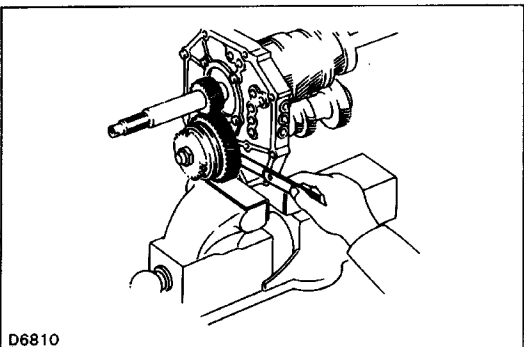

**12. INSPECT COUNTER FIFTH GEAR THRUST CLEARANCE**

Using a feeler gauge, measure the counter 5th gear thrust clearance.

**Standard clearance: 0.10 – 0.35 mm**

**(0.0039 – 0.0138 in.)**

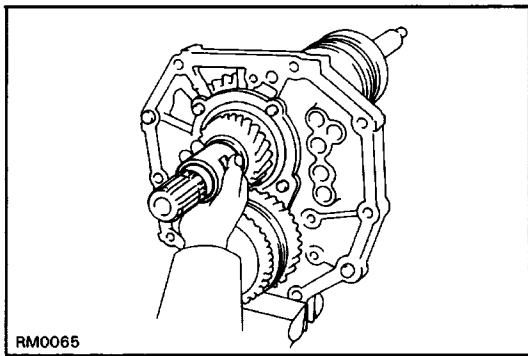

**13. INSTALL SPACER**

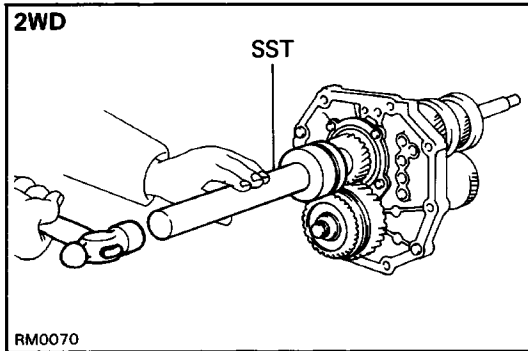

**14. INSTALL OUTPUT SHAFT REAR BEARING**

Using SST and a hammer, drive in the rear bearing.

SST (2WD) 09309-35010

(4WD) 09316-60010

(09316-00010, 09316-00070)

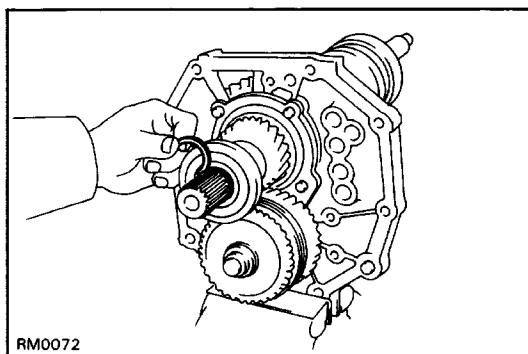
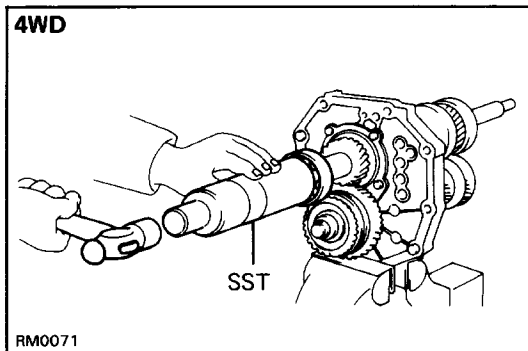

**15. INSTALL SNAP RING**

(a) Select a snap ring that will allow minimum axial play.

Mark	Thickness mm (in.)	Mark	Thickness mm (in.)
A	2.65 - 2.70 (0.1043 - 0.1063)	K	3.10 - 3.15 (0.1220 - 0.1240)
B	2.70 - 2.75 (0.1063 - 0.1083)	L	3.15 - 3.20 (0.1240 - 0.1260)
C	2.75 - 2.80 (0.1083 - 0.1102)	M	3.20 - 3.25 (0.1260 - 0.1280)
D	2.80 - 2.85 (0.1102 - 0.1122)	N	3.25 - 3.30 (0.1280 - 0.1299)
E	2.85 - 2.90 (0.1122 - 0.1142)	P	3.30 - 3.35 (0.1299 - 0.1319)
F	2.90 - 2.95 (0.1142 - 0.1161)	Q	3.35 - 3.40 (0.1319 - 0.1339)
G	2.95 - 3.00 (0.1161 - 0.1181)	R	3.40 - 3.45 (0.1339 - 0.1358)
H	3.00 - 3.05 (0.1181 - 0.1201)	S	3.45 - 3.50 (0.1358 - 0.1378)
J	3.05 - 3.10 (0.1201 - 0.1220)		

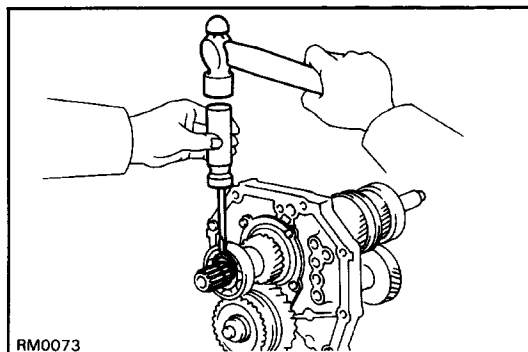

(b) Using a screwdriver and hammer, install the snap ring.



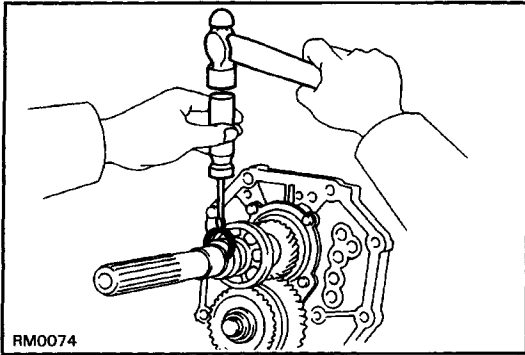

**16.-1(2WD)**  
**INSTALL SPEEDOMETER DRIVE GEAR**

- (a) Using a screwdriver and hammer, install the front snap ring.
- (b) Install the ball and drive gear.
- (c) Using a screwdriver and hammer, install the rear snap ring.

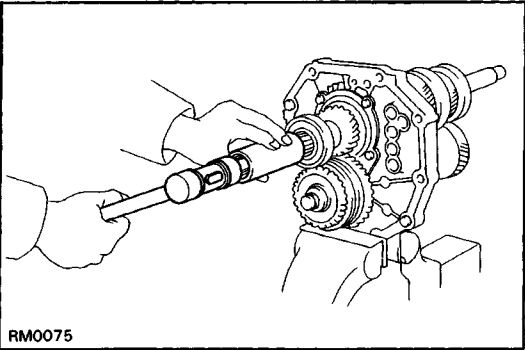

**16.-2(4WD)**  
**INSTALL SLEEVE TO OUTPUT SHAFT**

Using a plastic hammer, drive in the sleeve onto the output shaft.

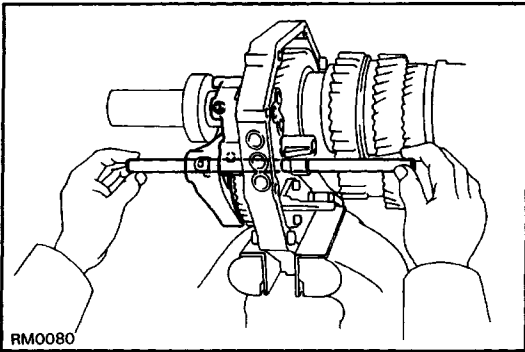

**17. INSTALL SHIFT FORK SHAFT NO.4, REVERSE SHIFT HEAD AND SHIFT FORK NO.3**

- (a) Place the shift fork No.3 into the groove of hub sleeve No. 3.
- (b) Install the shift fork shaft No.4 to shift fork No.3, reverse shift head and shift fork through the intermediate plate.
- (c) Install the locking ball into the reverse shift head.

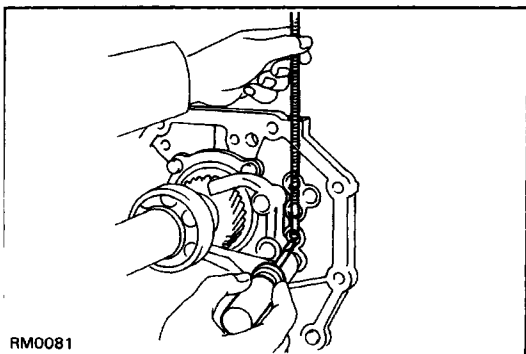

**18. INSTALL SHIFT FORK SHAFT NO.3 AND SHIFT FORK NO. 1**

- (a) Using a magnetic finger and screwdriver, install the locking ball into the intermediate plate.

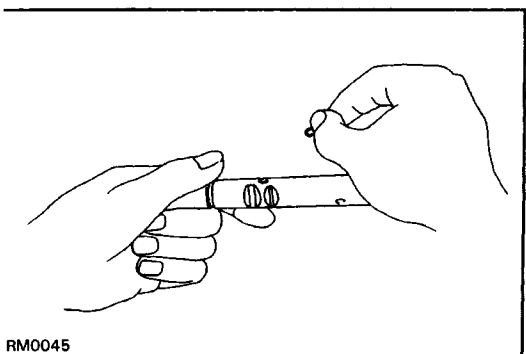

- (b) Install the interlock pin into the shaft hole.

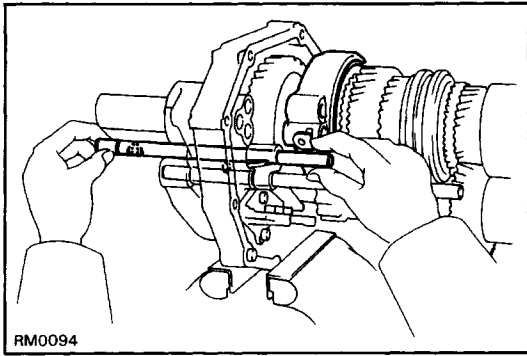

- (c) Place the shift fork No.1 into the groove of hub sleeve No. 1.
- (d) Install the fork shaft No.3 to the reverse shift fork and shift head through the intermediate plate.

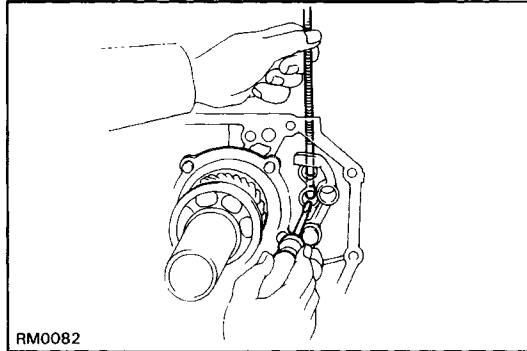

### 19. INSTALL SHIFT FORK SHAFT NO. 1

- (a) Using a magnetic finger and screwdriver, install the interlock pin into the intermediate plate.

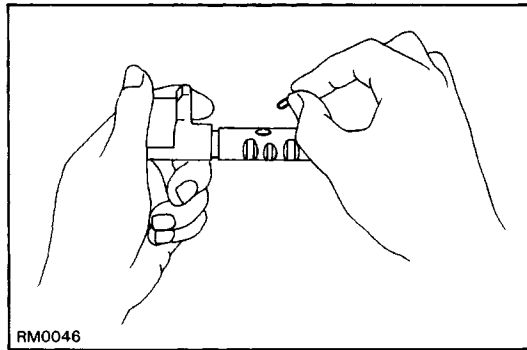

- (b) Install the interlock pin into the shaft hole.

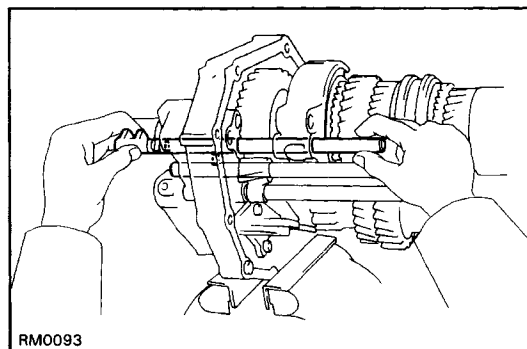

- (c) Install the fork shaft No. 1 to shift fork No. 1 through the intermediate plate.

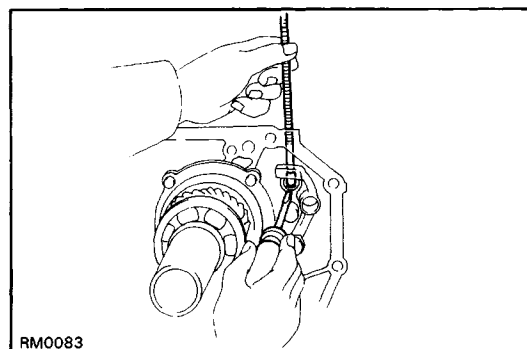

### 20. INSTALL SHIFT FORK SHAFT NO.2 AND SHIFT FORK

- (a) Using a magnetic finger and screwdriver, install the interlock into the intermediate plate.

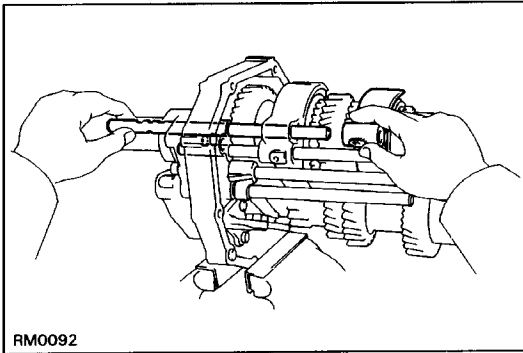

- (b) Place the shift fork No.2 into the groove of hub sleeve No.2.
- (c) Install fork shaft No.2 to shift fork No.1 and No.2 through the intermediate plate.

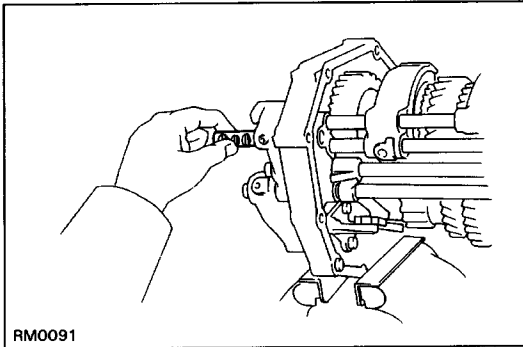

**21. INSTALL SHIFT FORK SHAFT NO.5**

Install the shift fork shaft No.5 to reverse shift head through the intermediate plate.

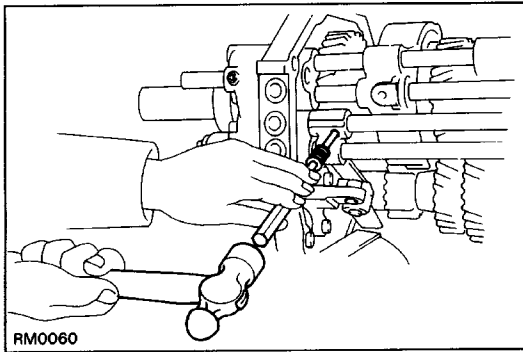

**22. INSTALL SLOTTED SPRING PINS**

Using a pin punch and hammer, drive in the two slotted spring pins to the reverse shift head and shift fork.

**23. CHECK INTERLOCK**

- (a) Shift fork shaft No. 1 to the 1 st speed position.
- (b) No.2, No.3, No.4 and No.5 fork shafts should not move.

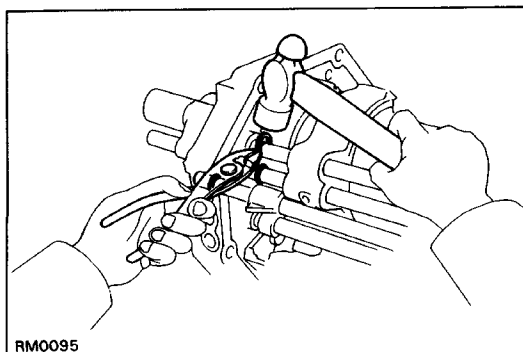

**24. INSTALL SNAP RINGS**

Using pliers and a hammer, install the three snap rings.

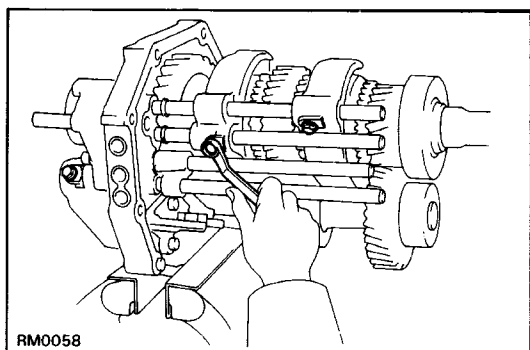
**25. INSTALL SET BOLTS**

Install and torque the three bolts.

**Torque: 20 N-m (200 kgf-cm, 14 ft-lbf)**

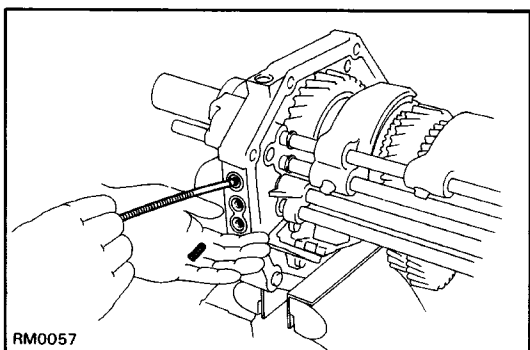
**26. INSTALL LOCKING BALLS, SPRINGS AND SCREW PLUGS**

(a) Apply liquid sealer to the plug threads.

**Sealant: Part No. 08833-00080, THREE BOND 1344, LOCTITE 242 or equivalent**

(b) Install the four locking balls, springs and screw plugs.

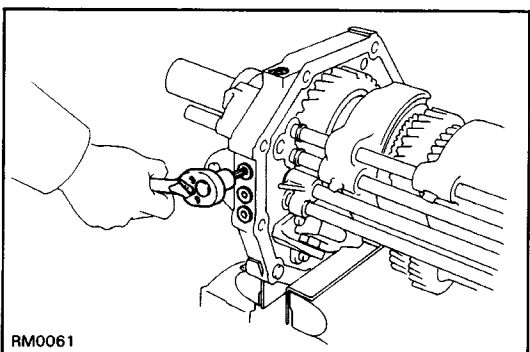

(c) Using a torx socket wrench, torque the screw plugs.

(Torx socket wrench T40 09042-00020)

**Torque: 19 N - m (190 kgf - cm, 14 ft - lbf )**

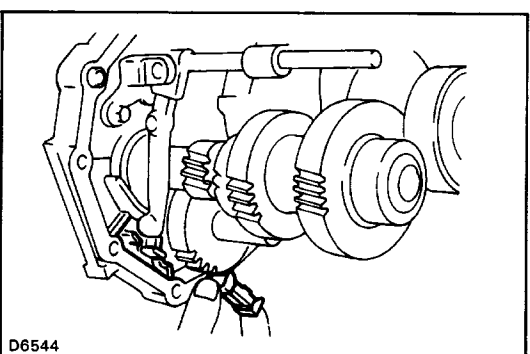
**27. INSTALL MAGNET TO INTERMEDIATE PLATE****28. DISMOUNT INTERMEDIATE PLATE FROM VISE**

(a) Dismount the intermediate plate from the vise.

(b) Remove the bolts, nuts and plate washers.

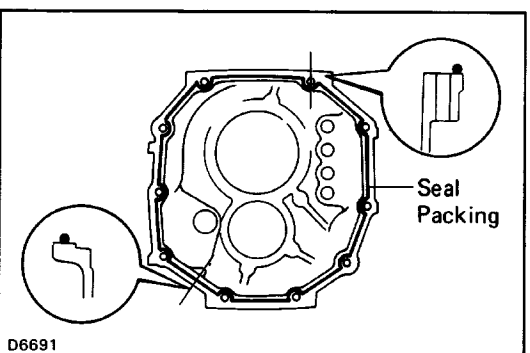
**29. INSTALL TRANSMISSION CASE**

(a) Remove the any packing material and be careful not to drop oil on the contacting surfaces of the intermediate plate or transmission case.

(b) Apply seal packing to the transmission case as shown.

**Seal packing: Part No. 08826-00090, THREE BOND 1281 or equivalent**

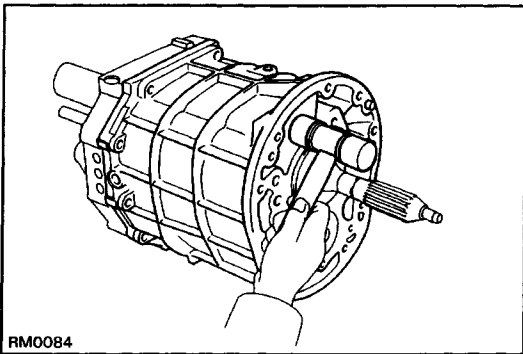

- (c) Align the each bearing outer race, each fork shaft end and reverse idler gear shaft end with the case installation holes, and install the case.  
If necessary, tap on the case with a plastic hammer.

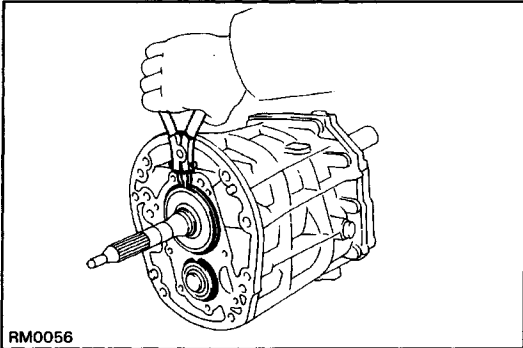

**30. INSTALL BEARING SNAP RINGS**

Using a snap ring expander, install the two snap rings to the input shaft bearing and counter gear front bearing.

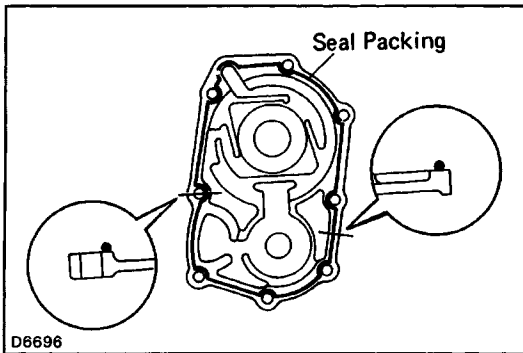

**31. INSTALL FRONT BEARING RETAINER**

- (a) Remove the any packing material and be careful not to drop oil on the contacting surfaces of the front bearing retainer or transmission case.  
(b) Apply seal packing to the retainer as shown.  
**Seal packing: Part No. 08826-00090, THREE BOND 1281 or equivalent**

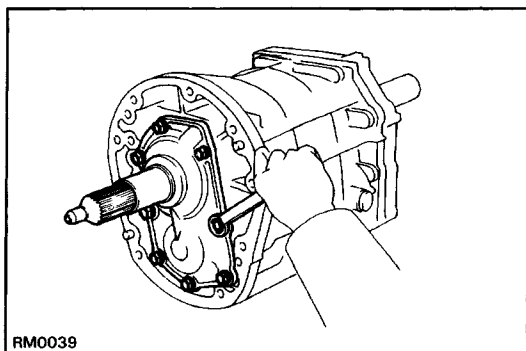

- (c) Apply liquid sealer to the bolt threads.  
**Sealant: Part No. 08833-00080, THREE BOND 1344, LOCTITE 242 or equivalent**  
(d) Install and torque the bolts.  
**Torque: 17 N – m (170 kgf – cm, 12 ft – lbf)**

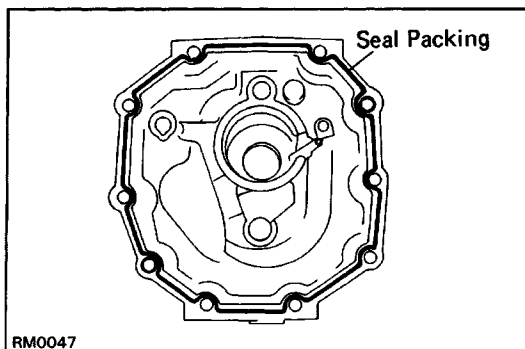

**32.-1 (2WD)**

**INSTALL EXTENSION HOUSING, SHIFT AND SELECT LEVER AND SHIFT LEVER HOUSING**

- (a) Remove the any packing material and be careful not to drop oil on the contacting surfaces of the extension housing or transmission case.  
(b) Apply seal packing to the extension housing as shown.  
**Seal packing: Part No. 08826-00090, THREE BOND 1281 or equivalent**

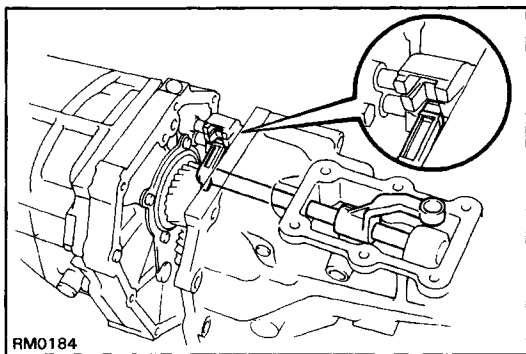

RM0184

- (c) Install the shift and select lever into the extension housing.
- (d) Connect the shift and select lever to the fork shaft and put in the shift lever housing.
- (e) Align the fork shaft No.5 to the extension housing installation hole and push in the extension housing.

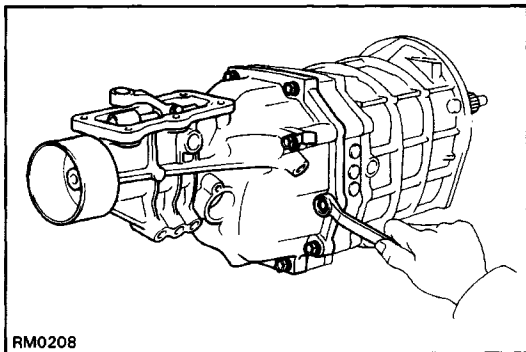

RM0208

- (f) Install and torque the extension housing bolts.  
Torque: 37 N-m (380 kgf-cm, 27 ft-lbf)

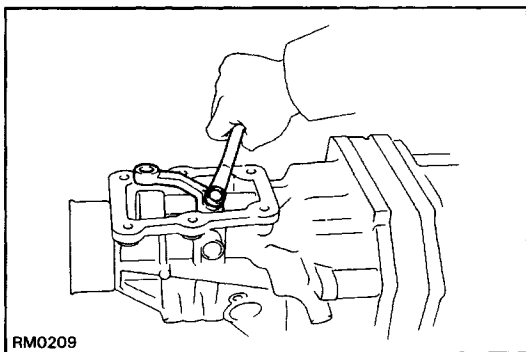

RM0209

- (g) Install and torque the shift lever housing bolt.  
Torque: 38 N-m (390 kgf-cm, 28 ft-lbf)

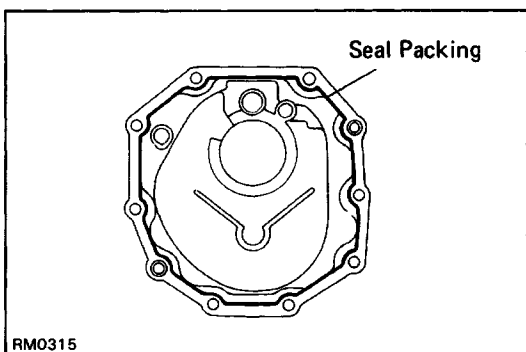

RM0315

### 32.-2(4WD)

#### INSTALL TRANSFER ADAPTOR, SHIFT LEVER SHAFT AND SHIFT LEVER HOUSING

- (a) Remove the any packing material and be careful not to drop oil on the contacting surfaces of the transfer adaptor or transmission case.
- (b) Apply seal packing to the transfer adaptor as shown.  
Seal packing: Part No. 08826-00090, THREE BOND 1281 or equivalent

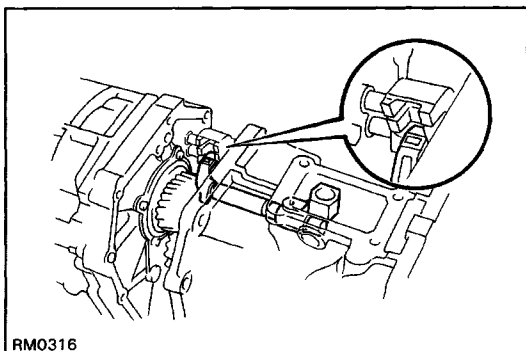

RM0316

- (c) Install the shift and select lever into the transfer adaptor.
- (d) Connect the shift and select lever to the fork shaft and put in the shift lever housing.
- (e) Align the fork shaft No.5 to the transfer adaptor installation hole and push in the transfer adaptor.

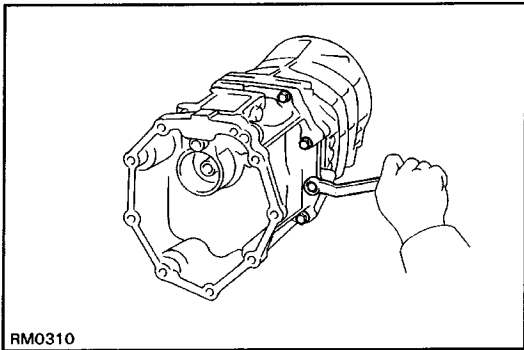

(f) Install and torque the bolts.  
**Torque: 37 N-m (380 kgf-cm, 27 ft-lbf)**

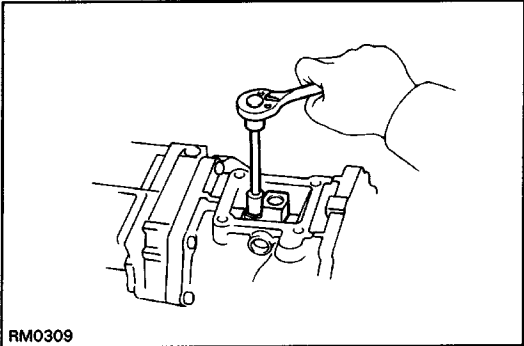

(g) Install and torque the shift lever housing bolt.  
**Torque: 38 N-m (390 kgf-cm, 28 ft-lbf)**

(h) Apply liquid sealer to the plug threads.  
**Sealant: Part No. 08833-00080, THREE BOND 1344, LOCTITE 242 or equivalent**

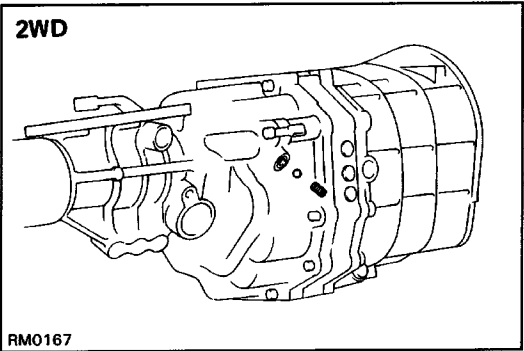

**33. INSTALL LOCKING BALL, SPRING AND SCREW PLUG**

(a) Apply liquid sealer to the plug threads.  
**Sealant: Part No. 08833-00080, THREE BOND 1344, LOCTITE 242 or equivalent**  
 (b) Install the locking ball, spring and plug.

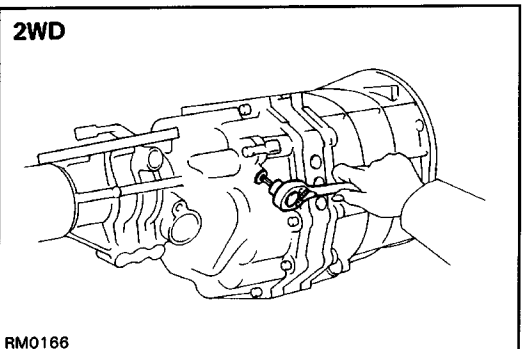
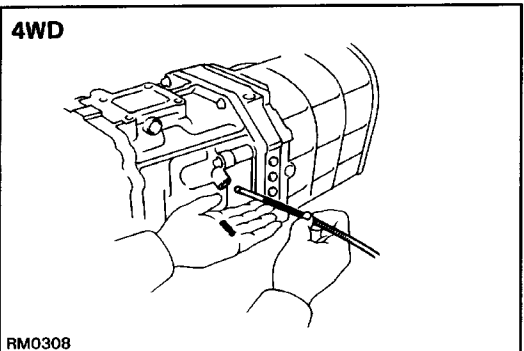

(c) Torque the plug.  
 (Torx socket wrench T40 09042-00020)  
**Torque: 19 N - m (190 kgf - cm, 14 f t - lbf)**

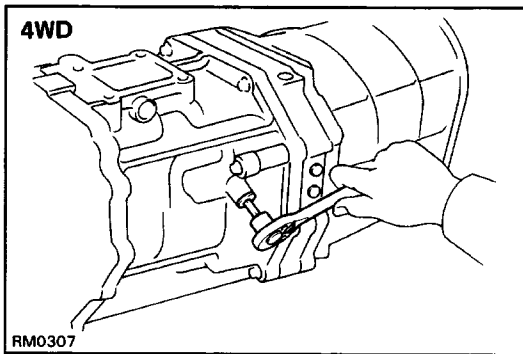

#### 34. AFTER INSTALLING EXTENSION HOUSING OR TRANSFER ADAPTOR CHECK FOLLOWING ITEMS

- (a) Check to see that the input and output shafts rotate smoothly.
- (b) Check to see that shifting can be made smoothly to all positions.

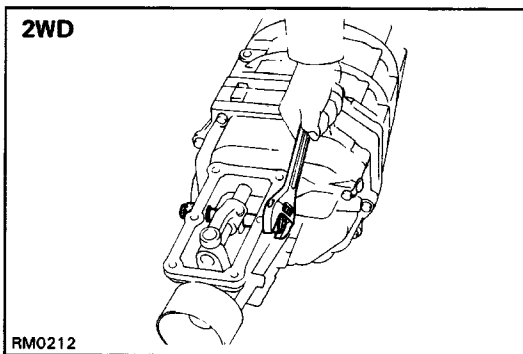

#### 35. INSTALL RESTRICT PINS

- (a) Install the black pin on the reverse gear/5th gear side.
- (b) Install another pin and torque the pins.  
**Torque: 37 N-m (380 kgf-cm, 27 ft-lbf)**

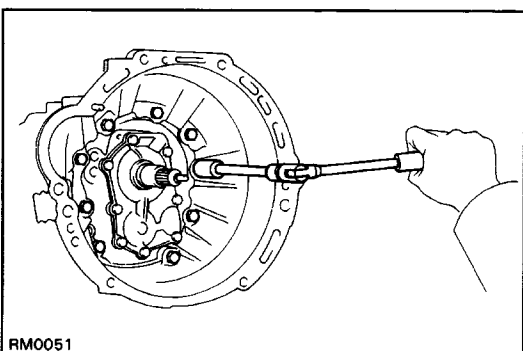
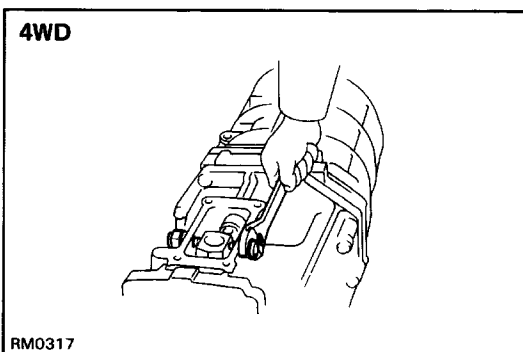

#### 36. INSTALL CLUTCH HOUSING

- (a) Install the clutch housing.
- (b) Install and torque the nine bolts.  
**Torque: 36 N-m (370 kgf-cm, 27 ft-lbf )**

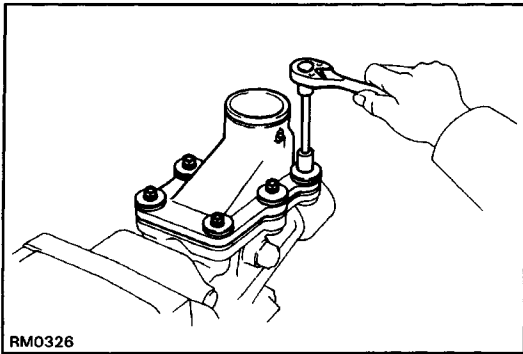

**37.-1 (2WD)****INSTALL SHIFT LEVER RETAINER**

Torque: 16 N-m (160 kgf-cm, 12 ft-lbf)

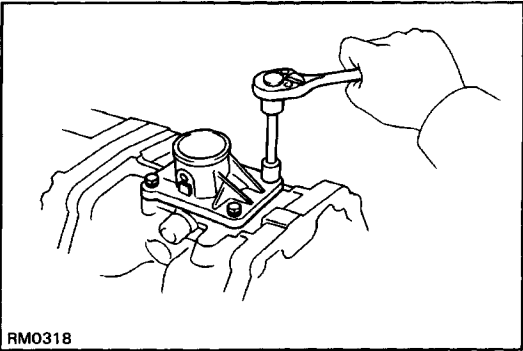
**37.-2(4WD)****INSTALL SHIFT LEVER RETAINERS WITH NEW GASKETS**

(a) Apply liquid sealer to the bolt threads.

**Sealant: Part No, 08833-00080, THREE BOND 1344, LOCTITE 242 or equivalent**

(b) Install the torque the four bolts.

Torque: 18 N – m (185 kgf – cm, 13 ft – lbf)

**38. INSTALL BACK-UP LIGHT SWITCH**

Torque: 37 N-m (380 kgf-cm, 27 ft-lbf)

**39. (2WD)****INSTALL SPEEDOMETER DRIVEN GEAR**

(a) Install speedometer driven gear and lock plate.

(b) Install and torque the bolt.

Torque: 11 N-m (115 kgf-cm, 8 ft-lbf)

**40. INSTALL RELEASE FORK AND BEARING**

(See page [CL-14](#))

# W55 AND W56 MANUAL TRANSMISSION

# DESCRIPTION

## PRECAUTIONS

When working with FIPG material, you must observe the following.

- Using a razor blade and gasket scraper, remove all the old packing (FIPG) material from the gasket surfaces.
- Thoroughly clean all components to remove all the loose material.
- Clean both sealing surfaces with a non-residue solvent.
- Apply the seal packing in approx. 1 mm (0.04 in.) bead along the sealing surface.
- Parts must be assembly within 10 minutes of application. Otherwise, the packing (FIPG) material must be removed and reapplied.

## DESCRIPTION

- The W55 and W56 manual transmissions are three-shift type, having an input shaft, output shaft and counter gear. Power is transmitted from the input shaft to the counter gear, and then to the output shaft which is co-axially fitted to the input shaft. The input shaft and the output shaft are engaged directly to each other in the 4th gear position.
- The 1st through 5th gears are constant mesh gears which use an inertia lock key type synchromesh mechanism. The reverse gear is a sliding mesh gear which is engaged by sliding the idler gear.
- W55 and W56 are manual transmissions use a single-cone synchromesh mechanism for the reverse gear.

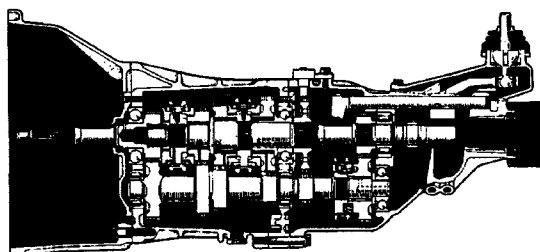

Q03080

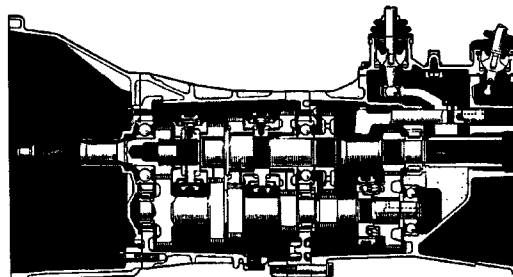

Q03081

Type of Transmission		W55	W56
Type of Engine		22R-E	
Gear Ratio	1st	3.566	3.954
	2nd	2.056	2.141
	3rd	1.384	←
	4th	1.000	←
	5th	0.850	←
	Reverse	4.091	←
Oil Capacity		2.6 liters (2.7 US.qts, 2.3 Imp.qts)	2.9 liters (3.0 US.qts, 2.6 Imp-qts)
Oil Viscosity		SAE 75W-90 or 80W-90	
Oil Grade		API GL-4	

# OPERATION

- The illustrations below show the engagements of transmission gears.



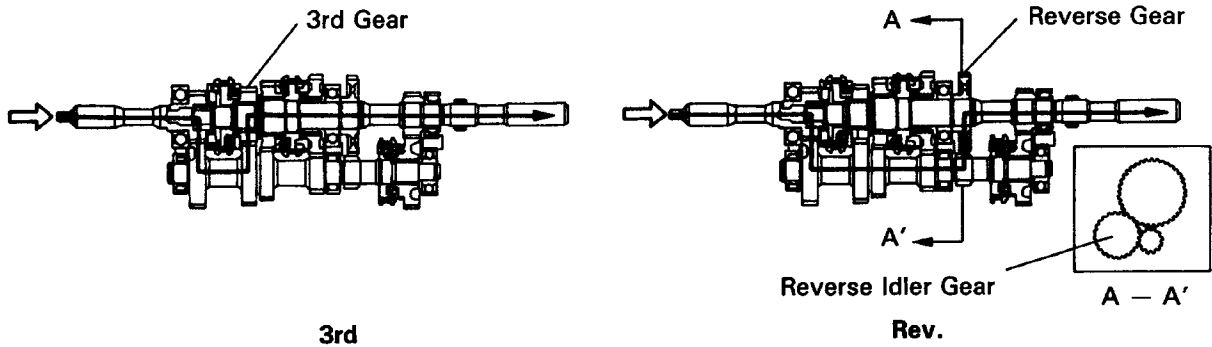
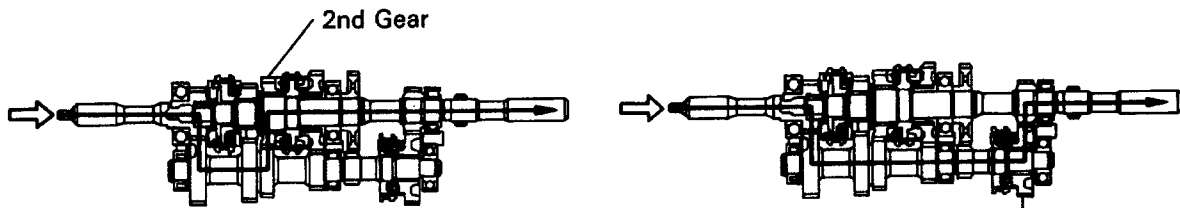
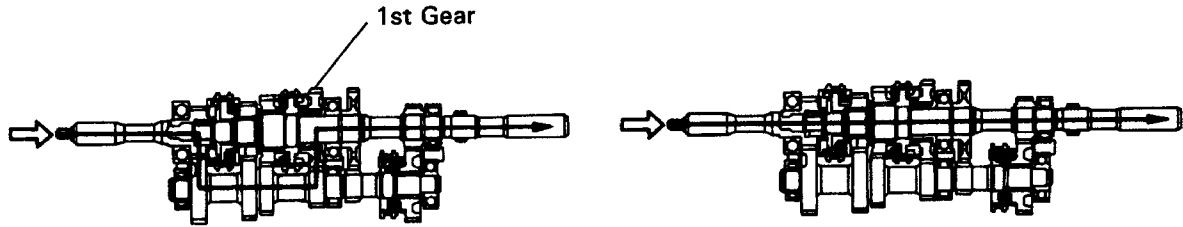







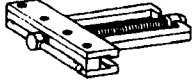

MT003-02





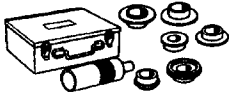







# PREPARATION

## SST (SPECIAL SERVICE TOOLS)

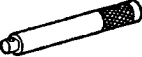

MT004-01

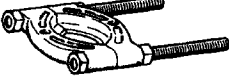
	<p>09213-36020 Timing Gear Remover</p>	
	<p>09308-00010 Oil Seal Puller</p>	
	<p>09308-10010 Oil Seal Puller</p>	
	<p>09312-20011 Transmission Gear Remover &amp; Replacer</p>	
	<p>(09313-00010) Reverse Gear Remover</p>	
	<p>(09313-00030) Rear Bearing Replacer</p>	
	<p>(09313-00040) Plate wAw</p>	
	<p>(09313-00050) Plate wBw</p>	
	<p>09316-60010 Transmission &amp; Transfer Bearing Replacer</p>	
	<p>(09316-00010) Replacer Pipe</p>	
	<p>09325-20010 Transmission Oil Plug</p>	
	<p>09506-35010 Differential Drive Pinion Rear Bearing Replacer</p>	
	<p>09608-12010 Front Hub &amp; Drive Pinion Bearing Replacer Set</p>	

MANUAL TRANSMISSION - PREPARATION

	<p>(09608-00020) Remover &amp; Replacer Handle</p>	
	<p>(09608-00050) Drive Pinion Front Bearing Cup Replacer</p>	
	<p>09608-20012 Front Hub &amp; Drive Pinion Bearing Tool Set</p>	
	<p>(09608-00080) Replacer</p>	
	<p>(09608-03020) Handle</p>	
	<p>09608-35014 Axle Hub &amp; Drive Pinion Bearing Tool Set</p>	
	<p>(09608-06020) Handle</p>	
	<p>(09608-06090) Front Hub Outer &amp; Steering Worm Bearing Replacer</p>	
	<p>(09608-06100) Front Hub Outer Replacer</p>	
	<p>09950-00020 Bearing Remover</p>	
	<p>09950-00030 Bearing Remover Attachment</p>	
	<p>09950-20017 Universal Puller</p>	

**RECOMMENDED TOOLS**

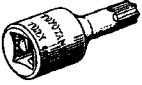
	09031-00030 Pin Punch	
	09905-00012 Snap Ring No. 1 Expander	
	09042-00020 Torx Socket t40	

MT006-01

**EQUIPMENT**

Dial indicator or dial indicator with magnetic base	
Torque wrench	

MT007-02

**LUBRICANT**

Item	Capacity	Classification
Manual transmission	2.6 liters (2.7 US qts, 2.3 Imp.qts)	API GL-4 SAE 75W-90 or 80W-90

MT008-01

**SSM (SPECIAL SERVICE MATERIALS)**

08826-00090 Seal Packing 1281, Three bond 1281 or equivalent	Transmission case x Intermediate plate Front bearing retainer x Transmission case
08833-00080 Adhesive 1344, THREE BOND 1344, LOCTITE 242 or equivalent	Straight screw plug Front bearing retainer bolt

# TROUBLESHOOTING

MT009-01  
 You will find the troubles using the table well shown in this table, each number shows the priority of causes in troubles. Check each part in order. If necessary, replace these parts.

	See page	Parts Name	Trouble
	-	Oil (Level low)	1
	MT2-2	Oil (Wrong)	2
	-	Oil (Level too high)	1
	MT2-10	Gasket (Damaged)	2
	MT2-14	Oil seal (Worn or damaged)	2
	MT2-10	O-Ring (Worn or damaged)	3
	MT2-10, 11	Locking ball spring (Damaged)	1
	MT2-11	Shift fork (Worn)	2
	MT2-11	Gear (Worn or damaged)	3
	MT2-11	Bearing (Worn or damaged)	3
	MT2-25, 3B	Synchronizer ring (Worn or damaged)	1
	MT2-25, 3B	Shifting key spring (Damaged)	2
Noise			1 2 3
Oil leakage			1 2 3
Hard to shift or will not shift			1 2
Jumps out of gear			1 2 3 3



# ASSEMBLY REMOVAL AND INSTALLATION

## TRANSMISSION REMOVAL AND INSTALLATION

MT081-01

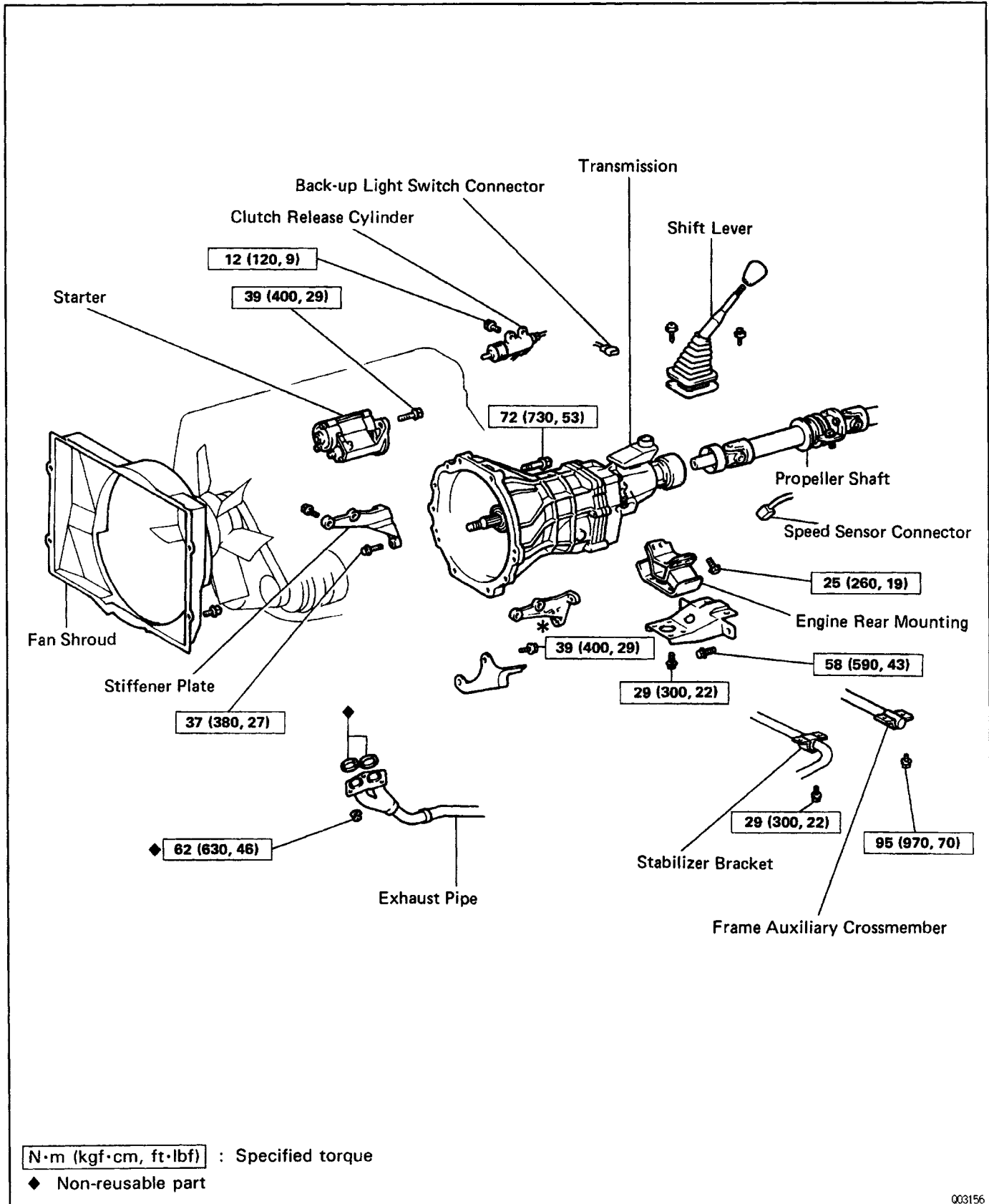

# TRANSMISSION WITH TRANSFER REMOVAL AND INSTALLTION

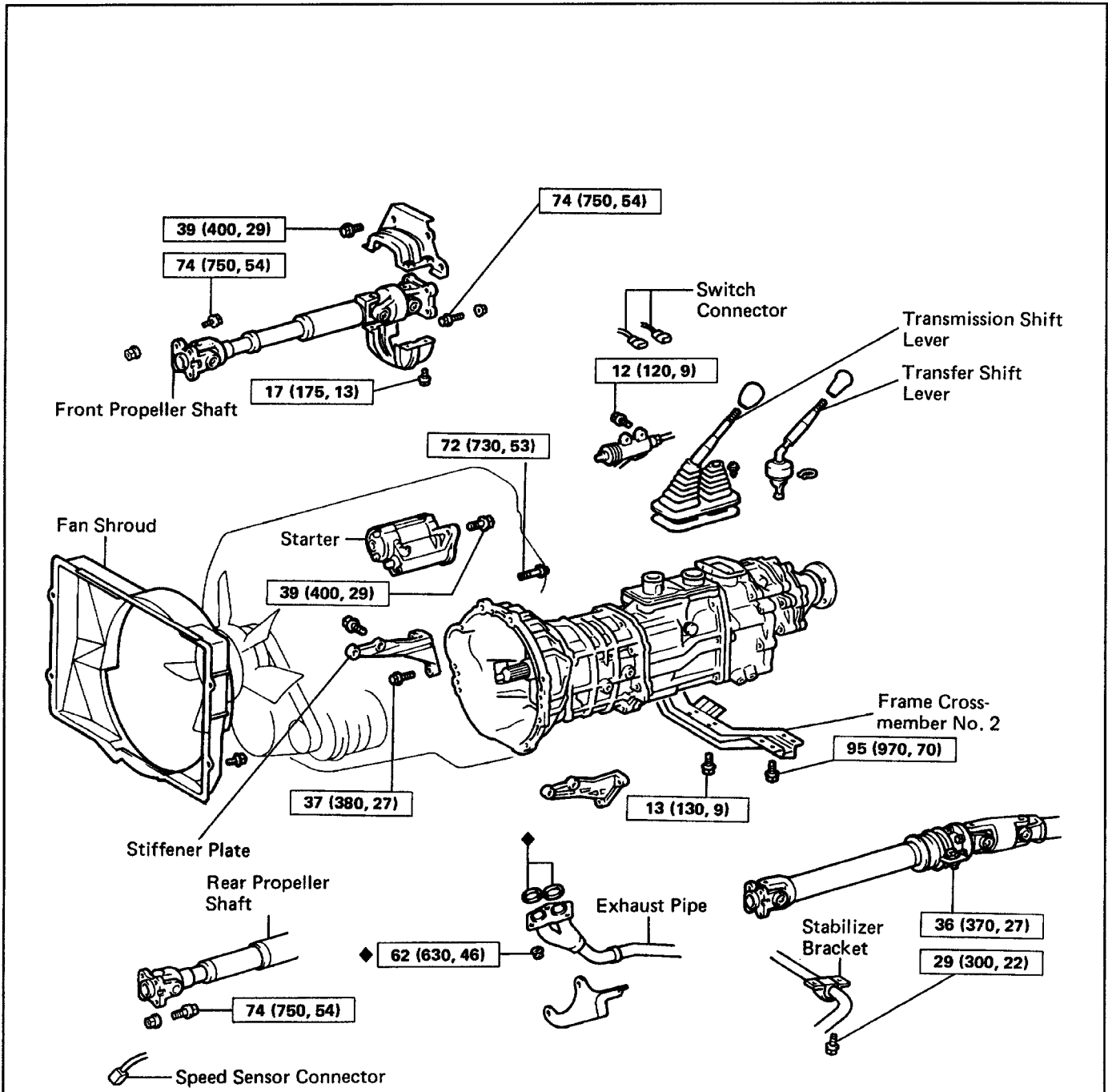

**N·m (kgf·cm, ft·lbf)** : Specified torque

◆ Non-reusable part

# COMPONENT PARTS REMOVAL

COMPONENTS

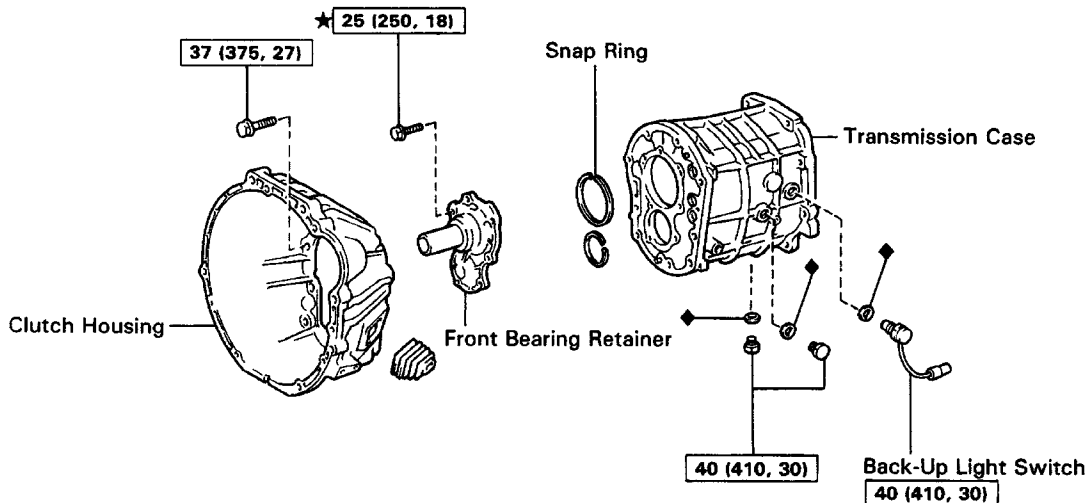

WM0319

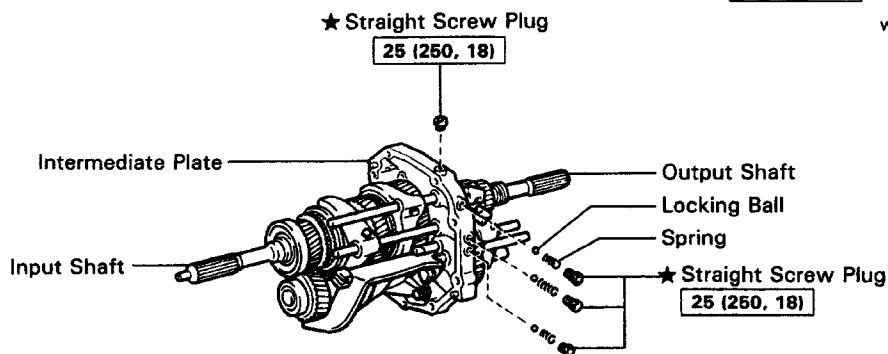

Q00944

2WD

4WD

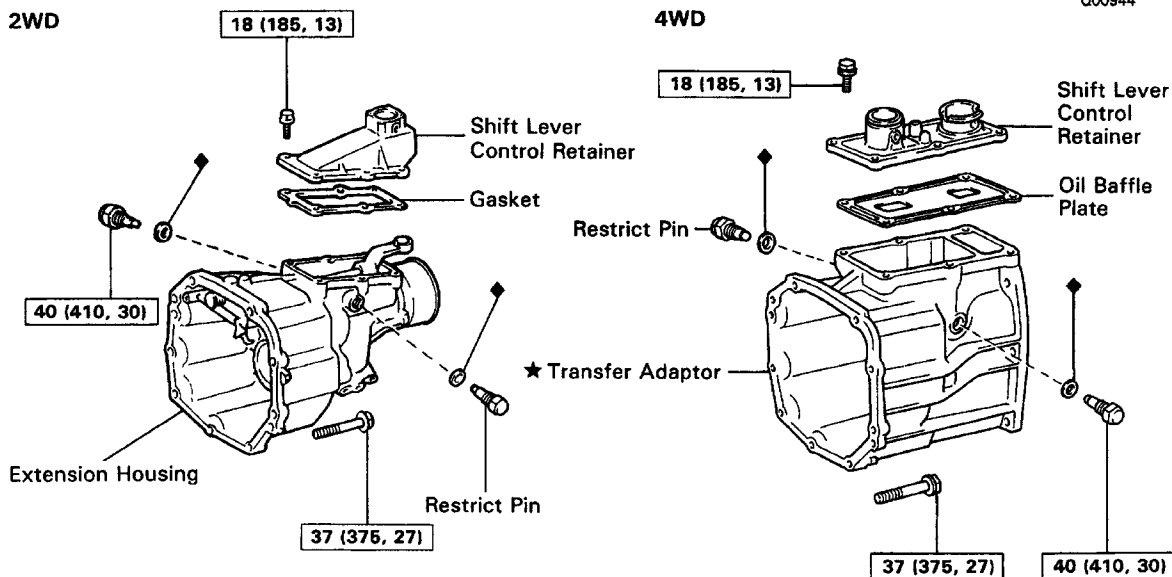

N·m (kgf·cm, ft·lbf) : Specified torque

Q01548

◆ Non-reusable part

★ Precoated part

Q03188

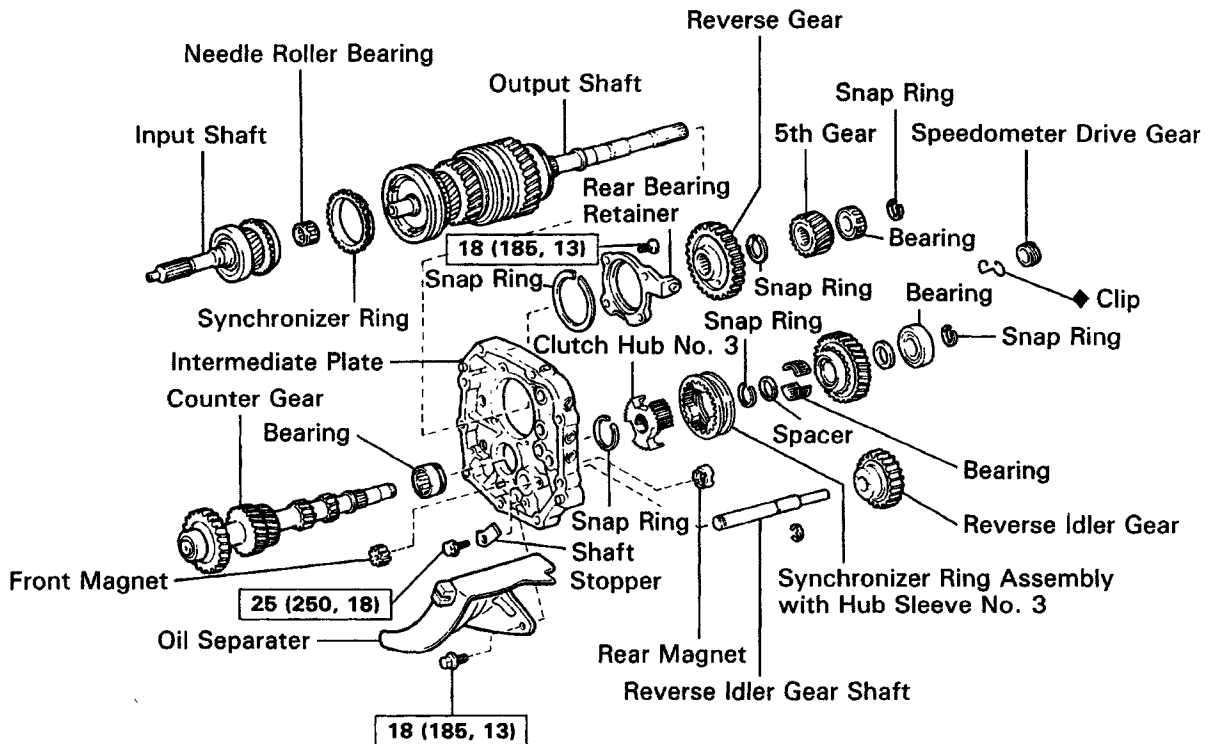
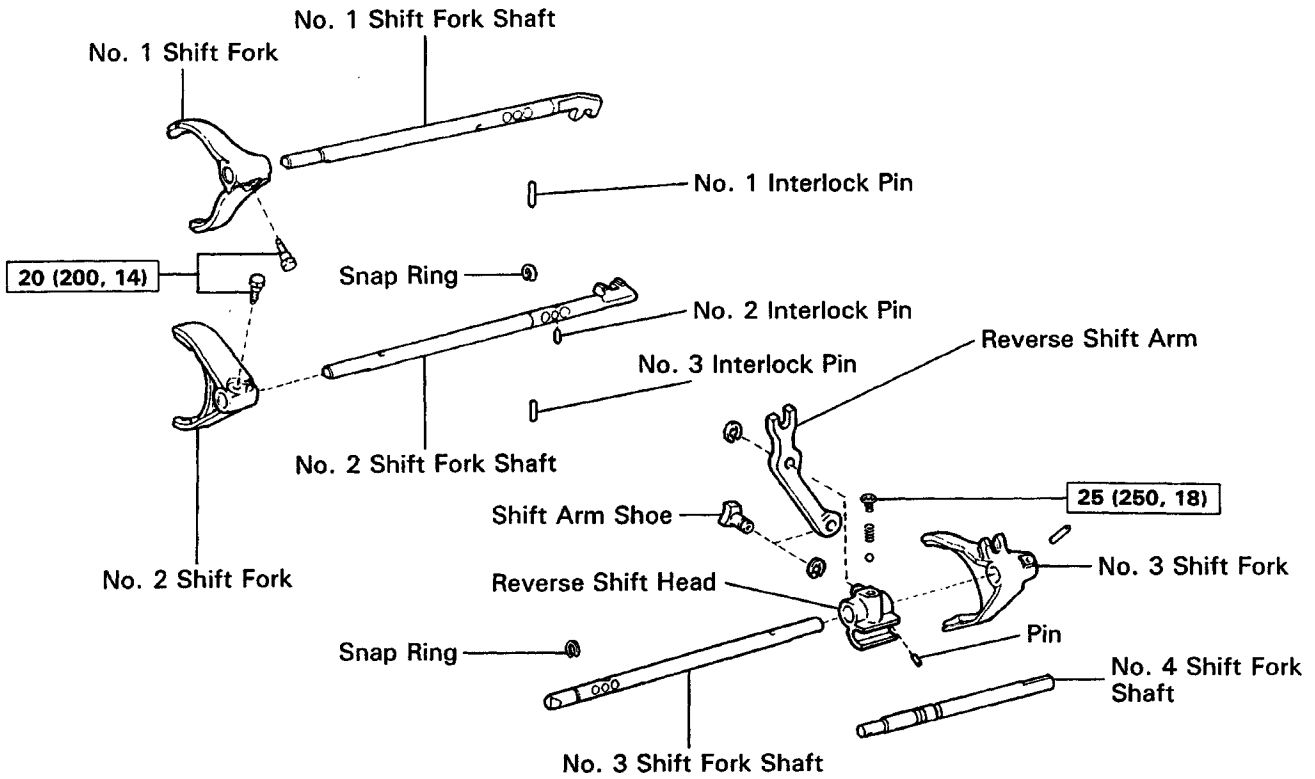

[N·m (kgf·cm, ft·lbf)] : Specified torque

◆ Non-reusable part

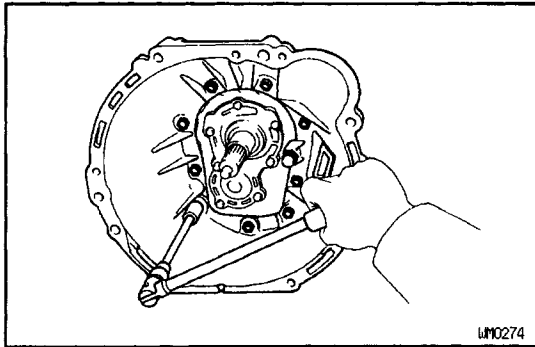

## BASIC SUBASSEMBLY SEPARATION

1. REMOVE BACK – UP LIGHT SWITCH, VEHICLE SPEED SENSOR (2WD) AND ENGINE REAR MOUNTING
2. REMOVE CLUTCH HOUSING FROM TRANSMISSION CASE

Remove the nine bolts and clutch housing from the transmission case.

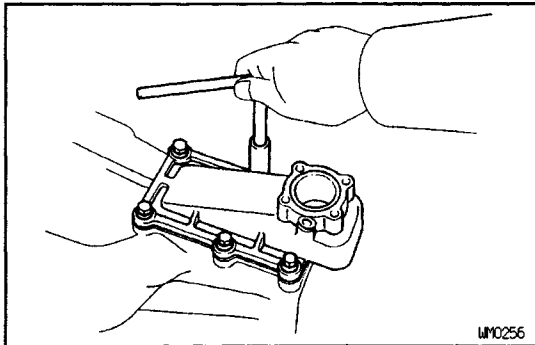

3. (2WD)  
REMOVE EXTENSION HOUSING

- (a) Remove the six bolts.
- (b) Remove the shift lever retainer and oil baffle plate.

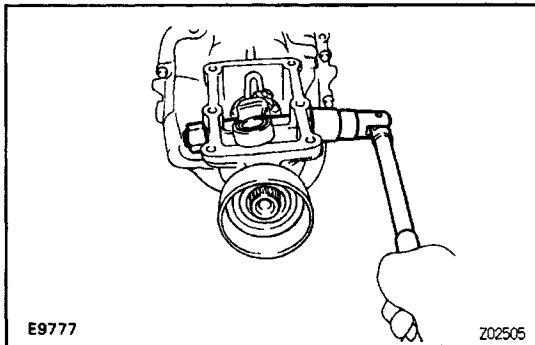

- (c) Remove the two restrict pins.

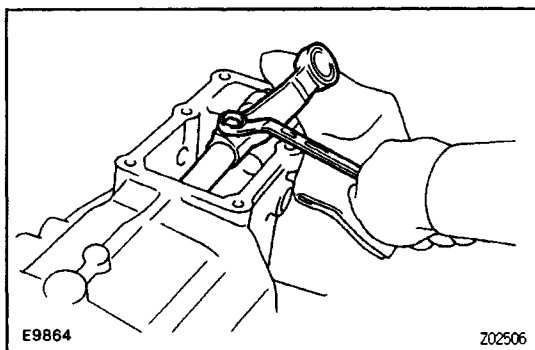

- (d) Remove the shift lever housing set bolt.

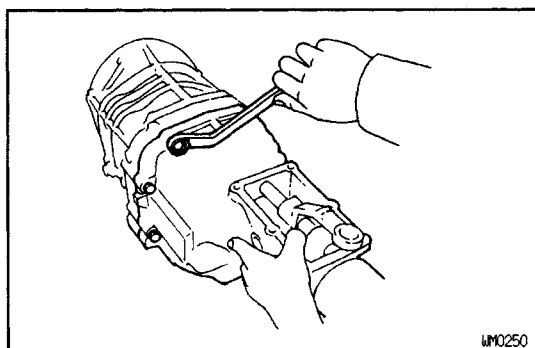

- (e) Remove the nine bolts.
- (f) Using a plastic hammer, tap the extension housing.
- (g) Disengage the shift and select lever from the shift head.
- (h) Pull out the extension housing.

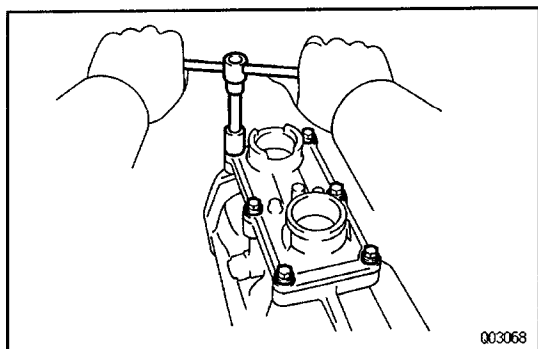
**4. (4WD)****REMOVE TRANSFER ADAPTOR**

- (a) Remove the six bolts, shift lever retainer and gasket.
- (b) Remove the select return spring from the shift lever retainer.

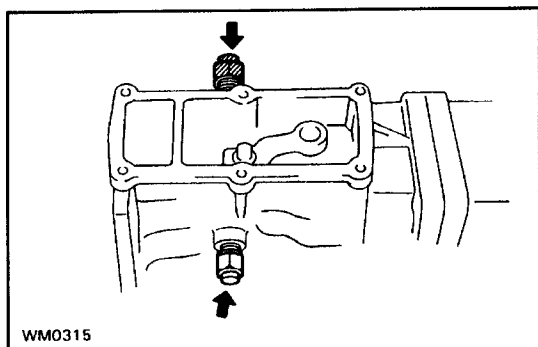

- (c) Remove the two restrict pins and gaskets.

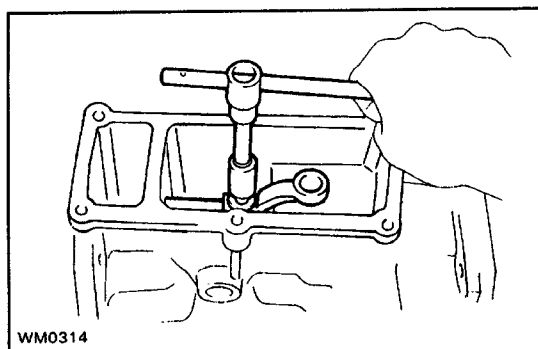

- (d) Remove the shift lever housing set bolt.

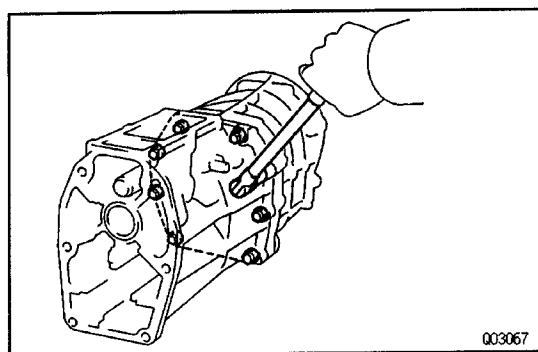

- (e) Remove the nine bolts.
- (f) Using a plastic hammer, tap the transfer adaptor.
- (g) Disengage the shift and select lever from the shift head.
- (h) Pull out the transfer adaptor.

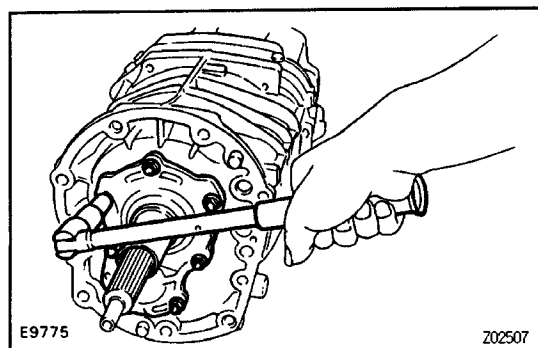
**5. REMOVE FRONT BEARING RETAINER AND BEARING SNAP RINGS**

- (a) Remove the seven bolts and front bearing retainer.

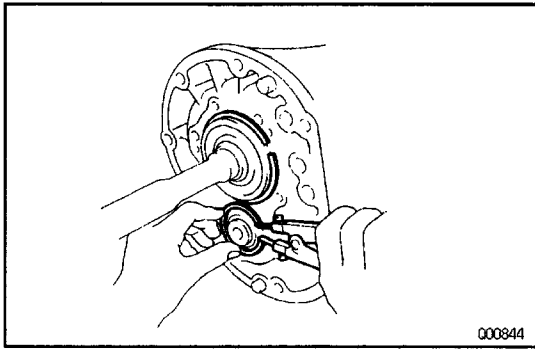

- (b) Using a snap ring pliers, remove the two bearing snap rings.

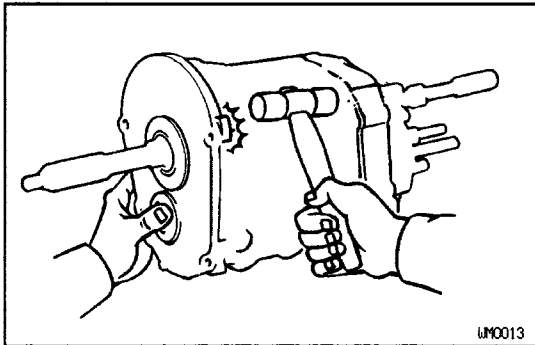

## 6. SEPARATE INTERMEDIATE PLATE FROM TRANSMISSION CASE

- (a) Using a plastic hammer, carefully tap the transmission case.  
 (b) Pull the transmission case from the intermediate plate.

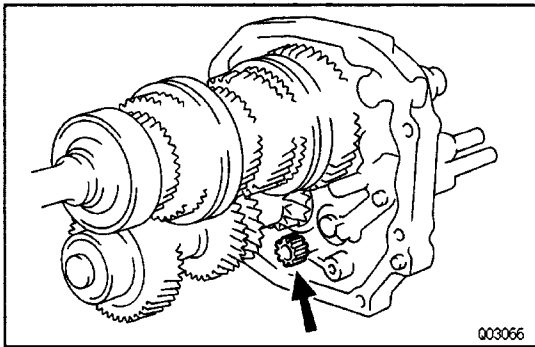

## 7. REMOVE FRONT MAGNET

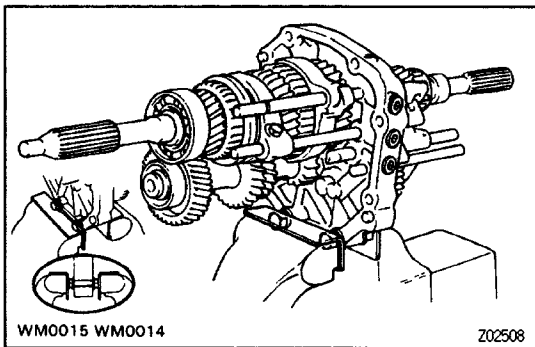

## 8. MOUNT INTERMEDIATE PLATE IN VISE

- (a) Use two long clutch housing bolts, plate washers and suitable nuts as shown.

**NOTICE:** Install the plate washers in reverse of normal. Increase or decrease plate washers so that the bolt tip and the front tip surface of the nut are aligned.

- (b) Mount the intermediate plate in a vise.

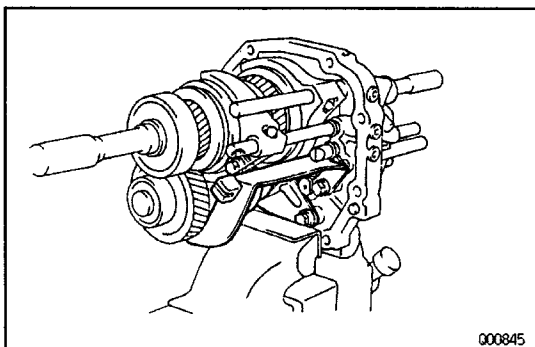

## 9. REMOVE OIL SEPARATOR

Remove the two bolts and oil receiver.

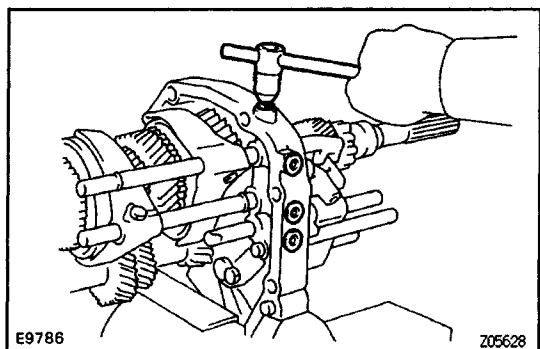

## 10. REMOVE LOCKING BALL AND SPRING

(a) Using a hexagon wrench, remove the four plugs.

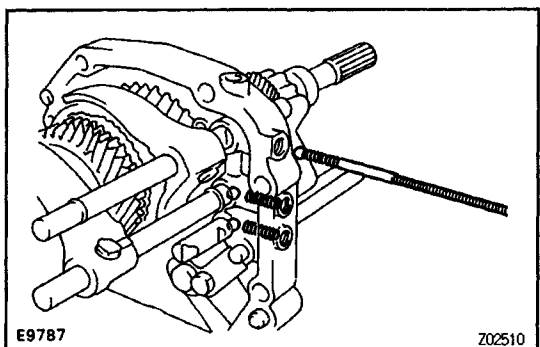

(b) Using a magnetic finger, remove the three springs and balls.

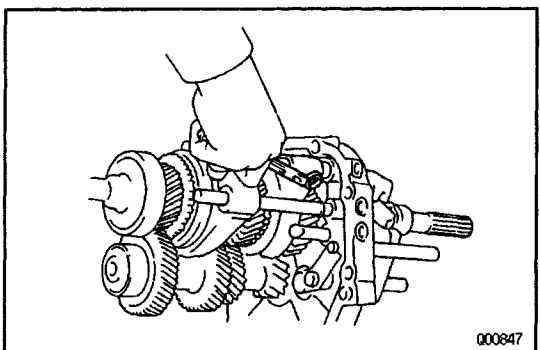

## 11. REMOVE SHIFT FORKS, SHIFT FORK SHAFTS AND REVERSE IDLER GEAR

(a) Remove the No. 1 shift fork set bolt.

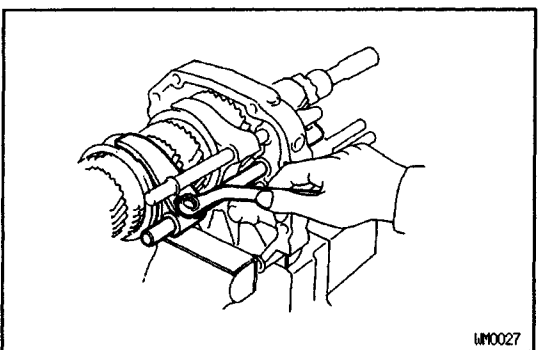

(b) Remove the No.2 shift fork set bolt.

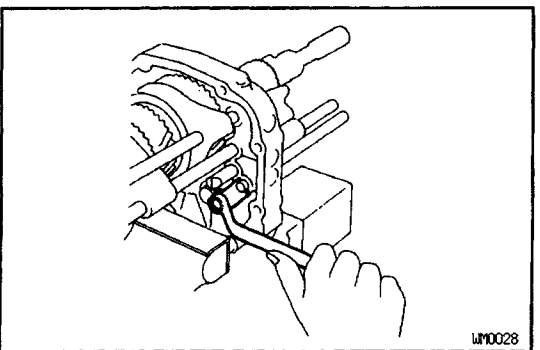

(c) Remove the reverse idler gear shift stopper.



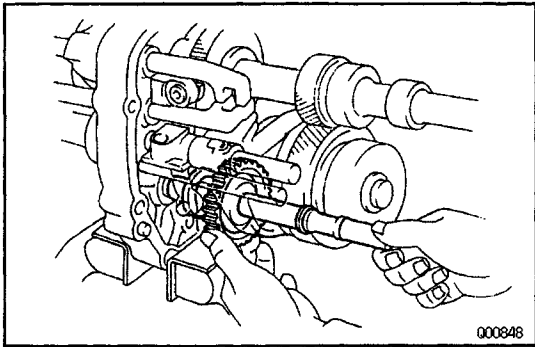

(d) Remove the reverse idler gear and shaft.

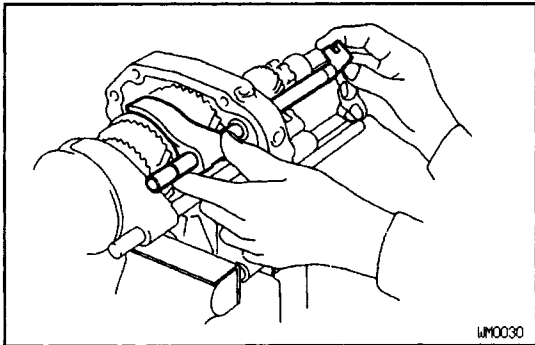

(e) Remove the No.1 shift fork and shaft.

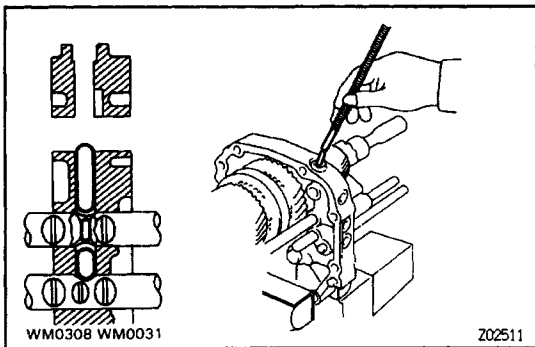

(f) Using a magnetic finger, remove the No-1 and No.2 interlock pins.

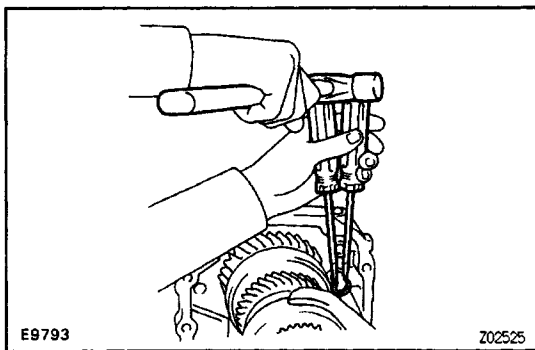

(g) Using two screwdrivers and a hammer, tap out the snap ring from the No.2 fork shaft.

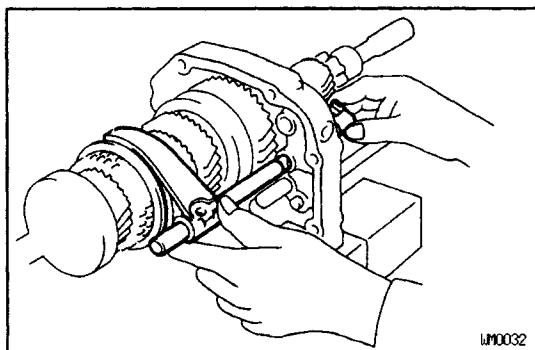

(h) Remove the No.2 shift fork and shaft.

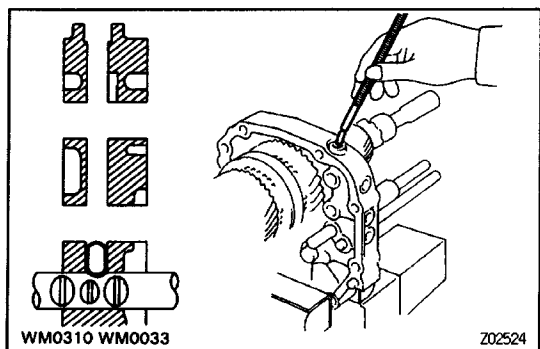

- (i) Using a magnetic finger, remove the No.3 interlock pin.

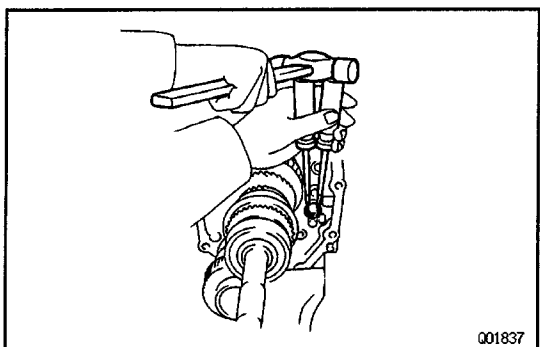

- (j) Using two screwdrivers and a hammer, tap out the snap ring from the No.3 fork shaft.

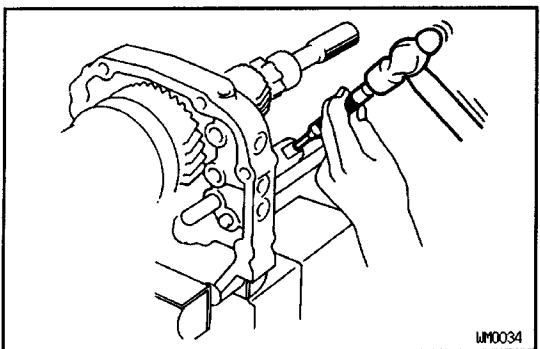

- (k) Using a pin punch and hammer, drive out the slotted spring pin from the No.3 shift fork.

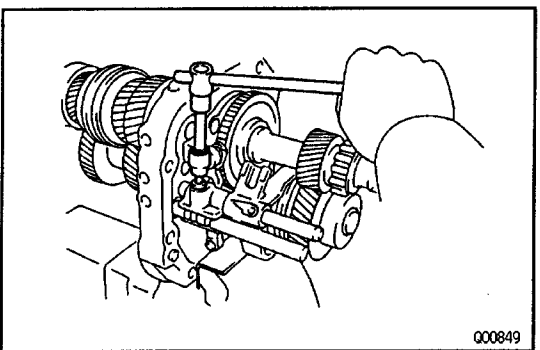

- (l) Using a hexagon wrench, remove the plug.

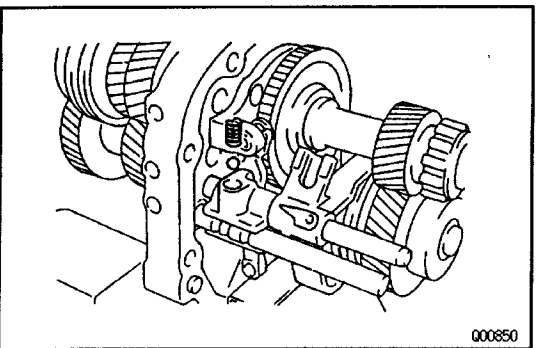

- (m) Using a magnetic finger, remove the spring and ball.

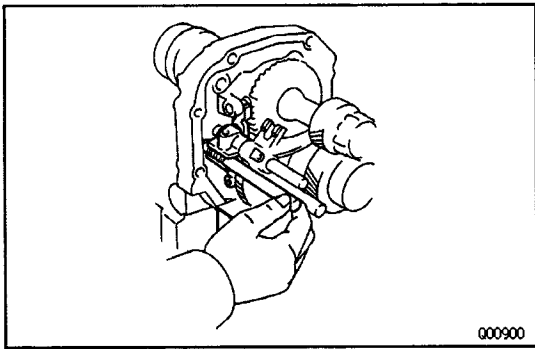

- (n) Pull out the No.4 shift fork shaft.
- (o) Remove the interlock pin.

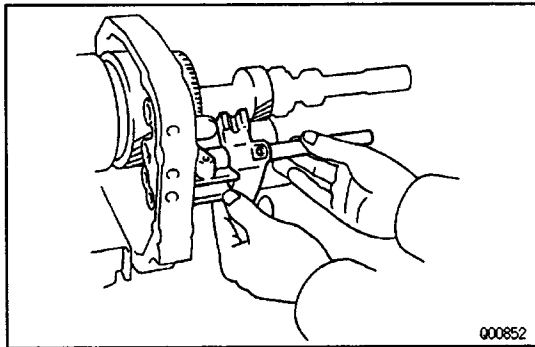

- (p) Remove the No.3 shift fork, fork shaft and reverse shift arm with the pin.

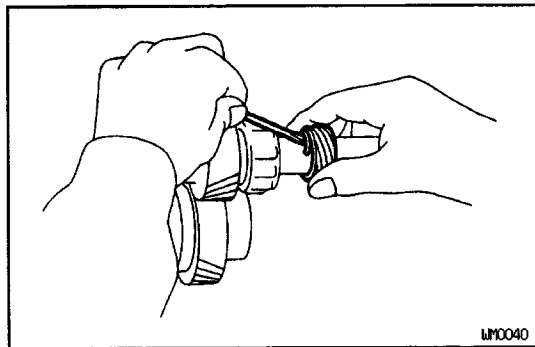

## 12. (2WD)

### REMOVE SPEED SENSOR DRIVE GEAR

Pry out both ends of the clip and remove the drive gear.

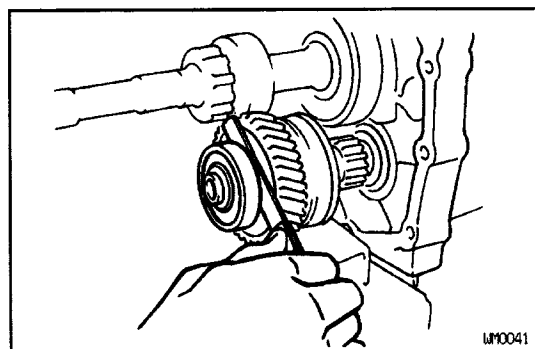

## 13. INSPECT COUNTER FIFTH GEAR THRUST CLEARANCE

Using feeler gauge, measure the counter 5th gear thrust clearance.

**Standard clearance:**

0.10–0.41 mm (0.0039–0.0161 in.)

**Maximum clearance:**

0.46 mm (0.0181 in.)

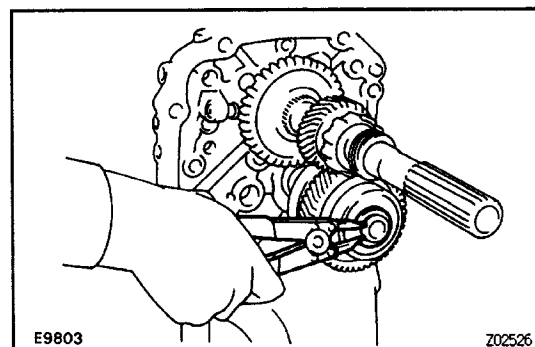

## 14. REMOVE COUNTER REAR BEARING, SPACER, COUNTER FIFTH GEAR AND NEEDLE ROLLER BEARING

- (a) Using a snap ring expander, remove the snap ring.

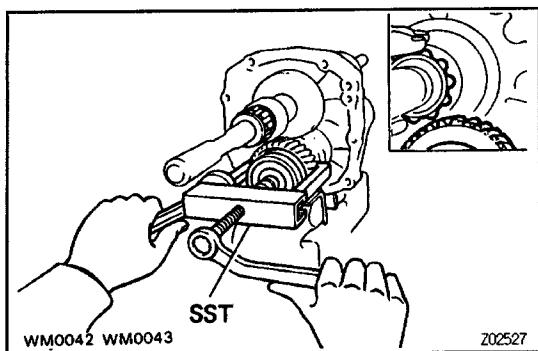

(b) Using SST, remove the rear bearing, spacer, 5th gear and bearing.

SST 09213-36020

**NOTICE:** Be careful not to catch the output shaft rear bearing roller on the counter 5th gear.

(c) Remove the spacer.

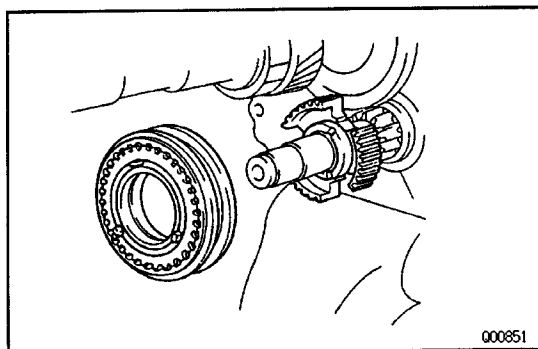

#### 15. REMOVE SYNCHRONIZER RING ASSEMBLY WITH NO.3 HUB SLEEVE AND NO.3 CLUTCH HUB

(a) Remove the synchronizer ring assembly with No.3 hub sleeve from the No.3 clutch hub.

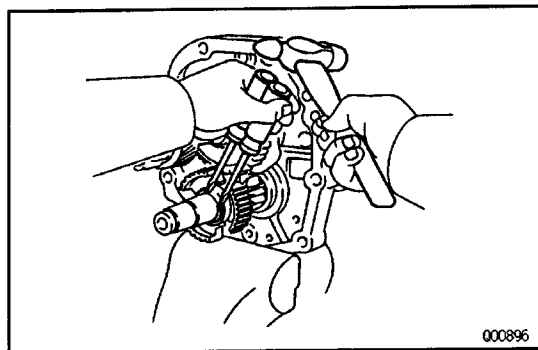

(b) Remove the spacer.

(c) Using two screwdrivers and a hammer, tap out the snap ring.

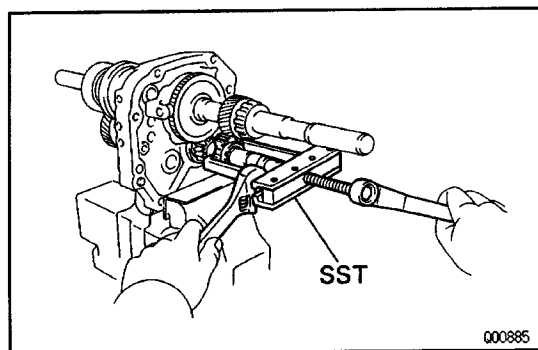

(d) Using SST, remove the No.3 clutch hub.

SST 09213-36020

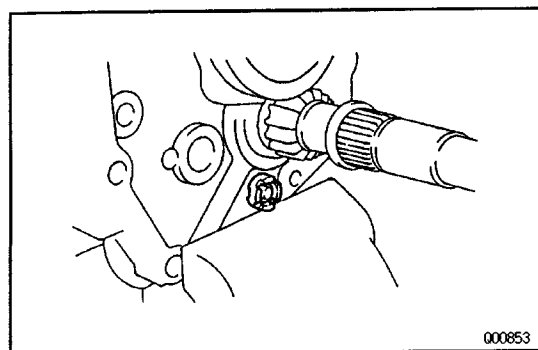

#### 16. REMOVE REAR MAGNET

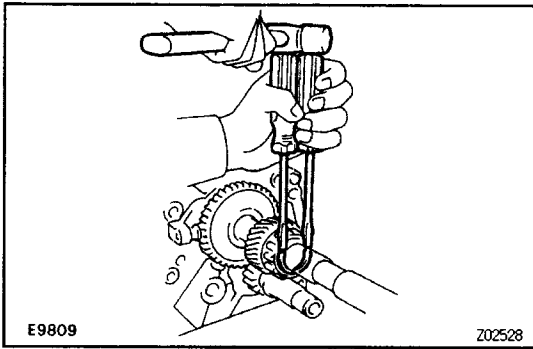

### 17. REMOVE OUTPUT SHAFT REAR BEARING AND FIFTH GEAR

- (a) Using two screwdrivers and a hammer, tap out the snap ring.

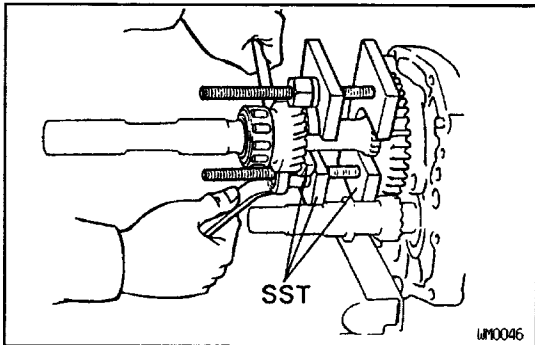

- (b) Using SST, remove the rear bearing and 5th gear.  
SST 09312-20011 (09313-00030, 09313-00040, 09313-00050)

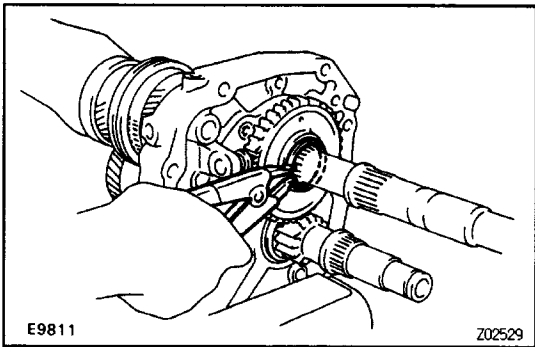

### 18. REMOVE REVERSE GEAR

- (a) Using a snap ring expander, remove the snap ring.

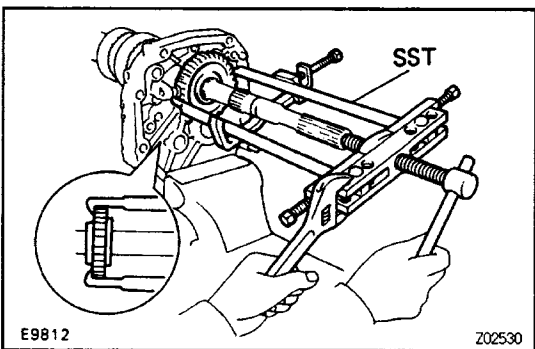

- (b) Using SST, remove the reverse gear.  
SST 09950-20017

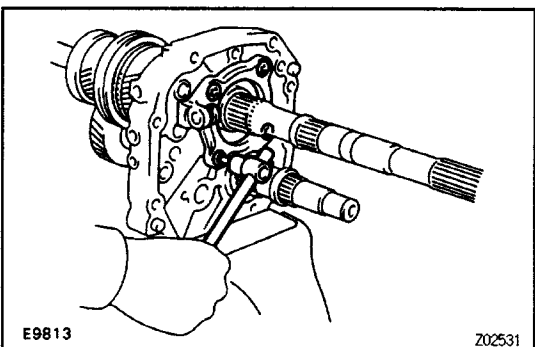

### 19. REMOVE CENTER BEARING RETAINER

- (a) Using a torx socket wrench, unscrew the torx screws and remove the retainer.  
Torx wrench T40 09042-00020

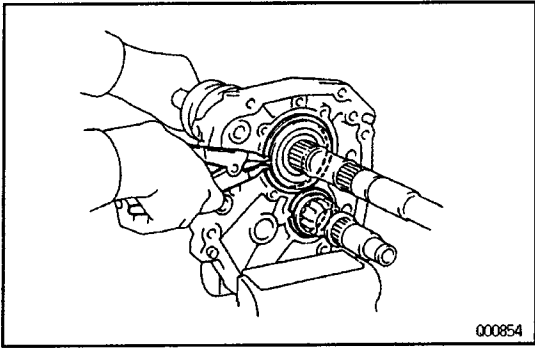

(b) Using a snap ring expander, remove the snap rings.

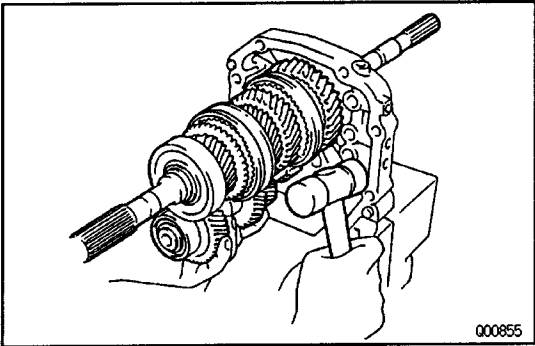

## 20. REMOVE OUTPUT SHAFT AND COUNTER GEAR AS A UNIT FROM INTERMEDIATE PLATE

- (a) Remove the output shaft, input shaft and counter gear as a unit from the intermediate plate by pulling on the counter gear and tapping on the intermediate plate with a plastic hammer.
- (b) Remove the input shaft from the output shaft.

# INPUT SHAFT COMPONENTS

MT00F-02

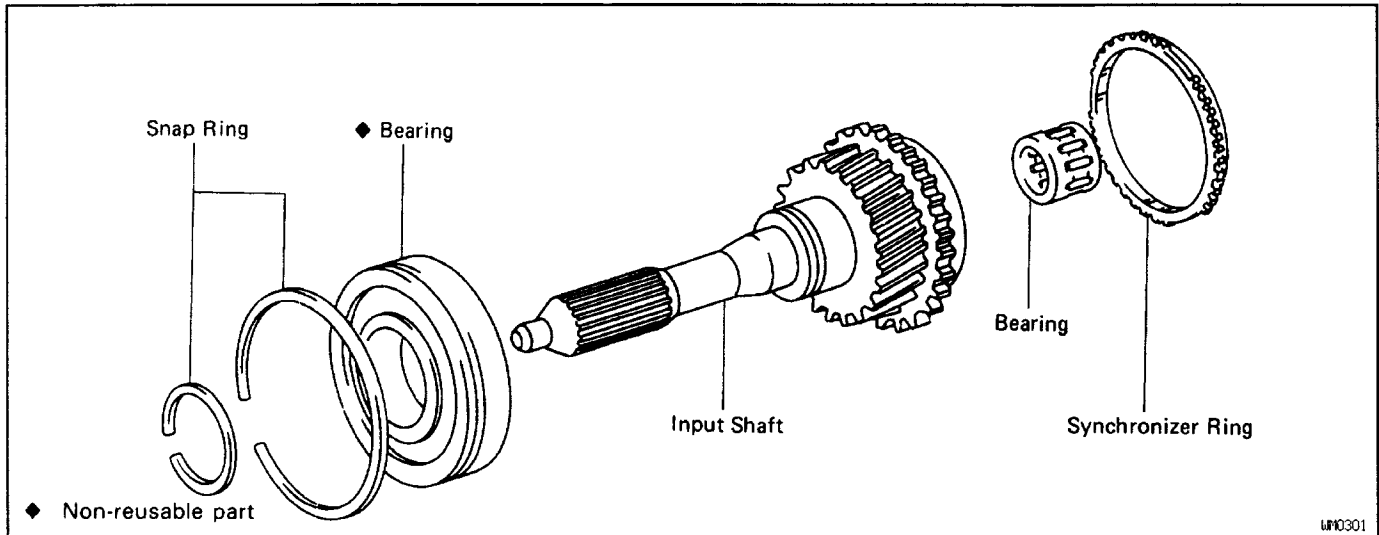

MT00G-02

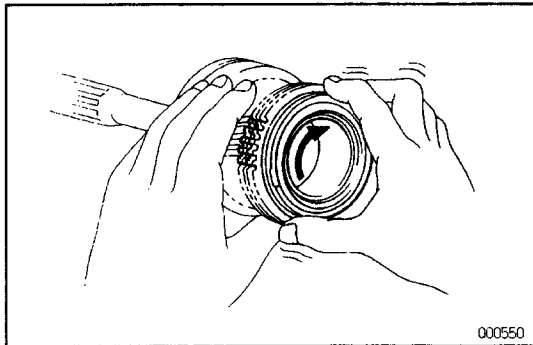

## INPUT SHAFT INSPECTION INSPECT SYNCHRONIZER RING

- (a) Check for wear or damage.
- (b) Check the braking effect of the synchronizer ring.  
Turn the synchronizer ring in one direction while pushing it to the gear cone and check that the ring is locked.  
If the braking effect is insufficient, apply a small amount of fine lapping compound between the synchronizer ring and gear cone.

### NOTICE:

- Wash off completely the fine lapping compound after rubbing.
- Check again the braking effect of the synchronizer ring.

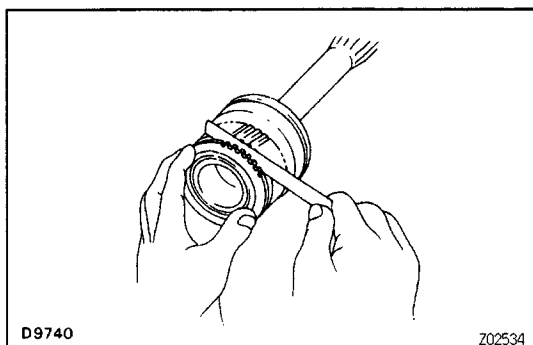

- (c) Using a feeler gauge, measure the clearance between the synchronizer ring back and the gear spline end.

### Minimum clearance:

0.5 mm (0.020 in.)

## HINT:

- When replacing either a synchronizer ring or gear, apply a small amount of fine compound between the synchronizer ring and gear cone. Lightly rub the synchronizer ring and gear cone together.
- When replacing both the synchronizer ring and gear, there is no need to apply any compound or to rub them together.

**NOTICE: Wash off completely the fine lapping compound after rubbing.**

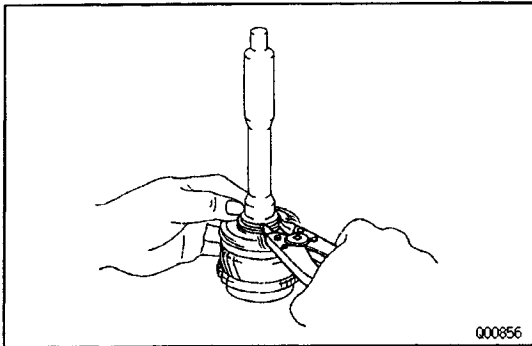

## BEARING REPLACEMENT

MT00H-01

### IF NECESSARY, REPLACE INPUT SHAFT BEARING

(a) Using a snap ring expander, remove the snap ring.

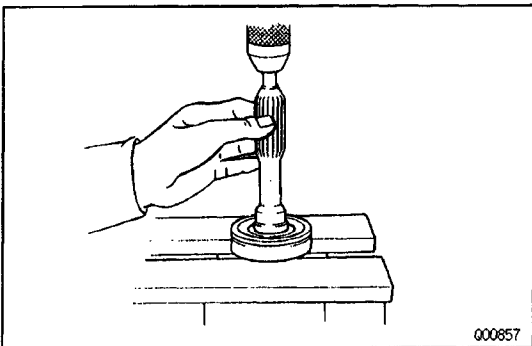

(b) Using a press, remove the bearing.

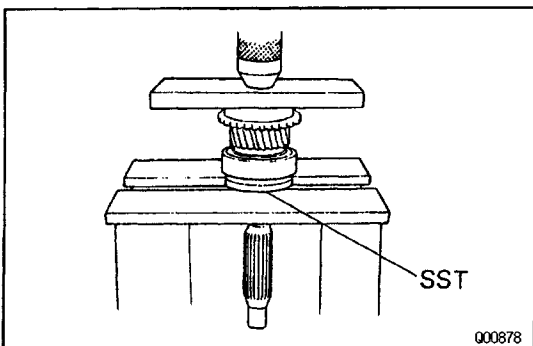

(c) Using SST and a press, install a new bearing.  
SST 09506-35010



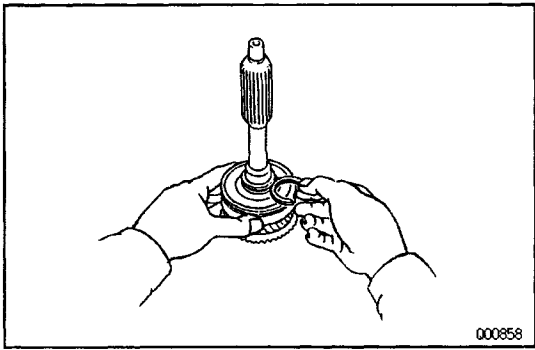

(d) Select a snap ring that will allow minimum axial play.

Mark	Thickness m m (in.)
1	2.05 - 2.10 (0.0807 - 0.0827)
2	2.10 - 2.15 (0.0827 - 0.0846)
3	2.15 - 2.20 (0.0846 - 0.0866)
4	2.20 - 2.25 (0.0866 - 0.0886)
5	2.25 - 2.30 (0.0886 - 0.0906)
11	2.30 - 2.35 (0.0906 - 0.0925)
12	2.35 - 2.40 (0.0925 - 0.0945)

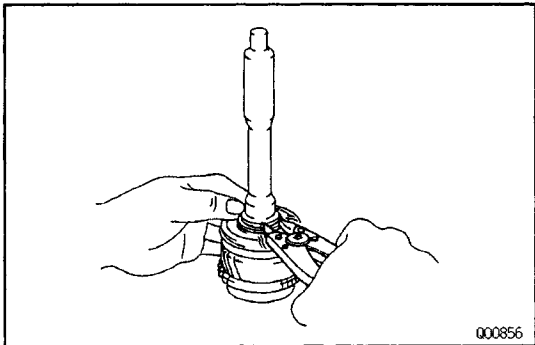

(e) Using a snap ring expander, install the snap ring.

# OUTPUT SHAFT COMPONENTS

MT001-02

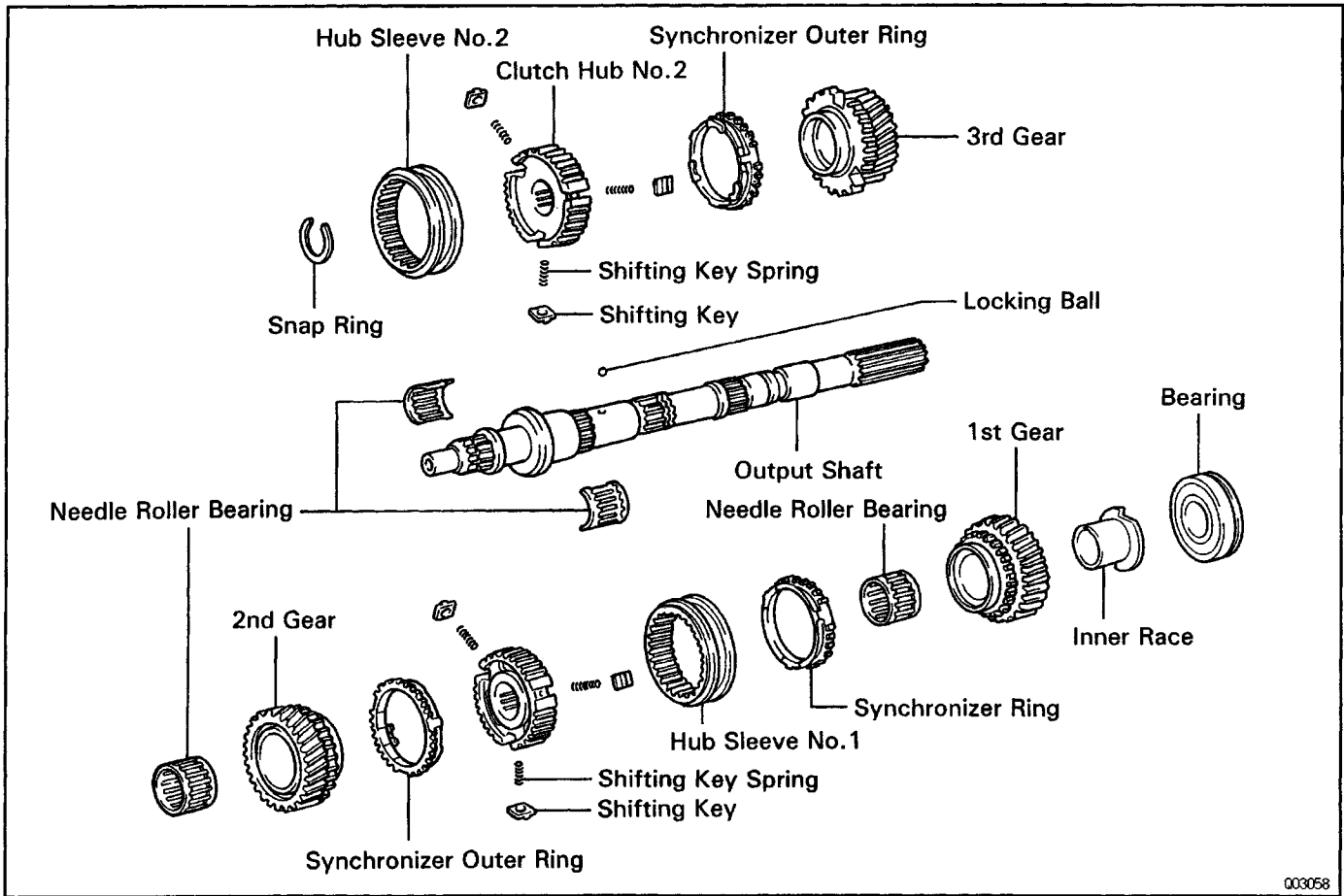

003058

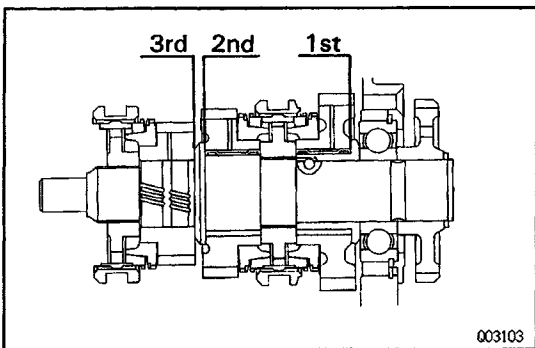

003103

## OUTPUT SHAFT DISASSEMBLY

MT00K-02

### 1. INSPECT EACH GEAR THRUST CLEARANCE

Using a feeler gauge, measure the thrust clearance of each gear.

**Standard clearance:**

0.10–0.25 mm (0.0039–0.0098 in.)

**Maximum clearance:**

0.30 mm (0.0118 in.)

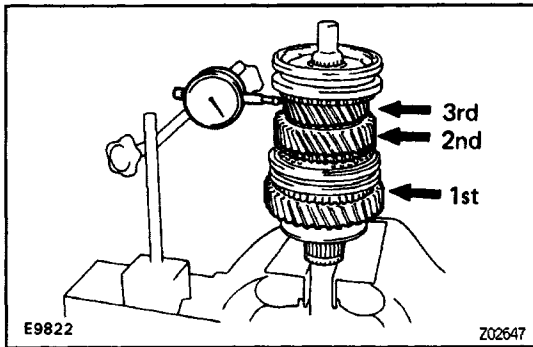

## 2. INSPECT EACH GEAR OIL CLEARANCE

Using a dial indicator, measure the oil clearance of each gear.

**Standard clearance:**

**1 st and 2nd gear**

0.009–0.060 m m (0.0004–0.0024 in.)

**3rd gear**

0.015–0.066 mm (0.0006–0.0026 in.)

**Maximum clearance:**

**1st and 2nd gear**

0.15 mm (0.0059 in.)

**3rd gear**

0.20 mm (0.0079 in.)

If the clearance exceeds the maximum, replace the gear, shaft or needle roller bearing.

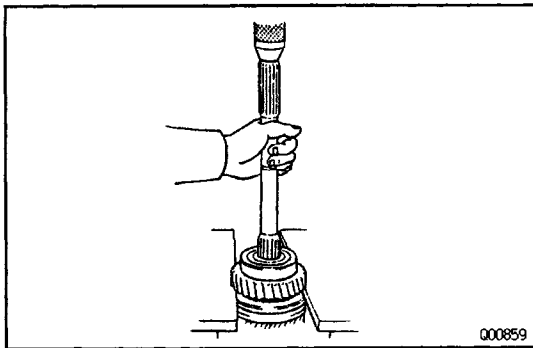

## 3. REMOVE OUTPUT SHAFT CENTER BEARING AND FIRST GEAR ASSEMBLY

(a) Shift the No. 1 hub sleeve onto the 2nd gear.

(b) Using a press, remove the center bearing, 1st gear, needle roller bearing, inner race and synchronizer ring.

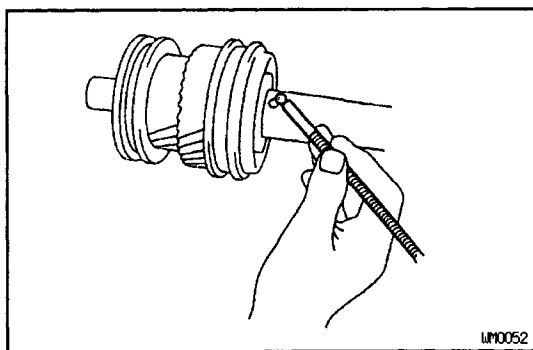

## 4. REMOVE LOCKING BALL

Using a magnetic finger, remove the locking ball.

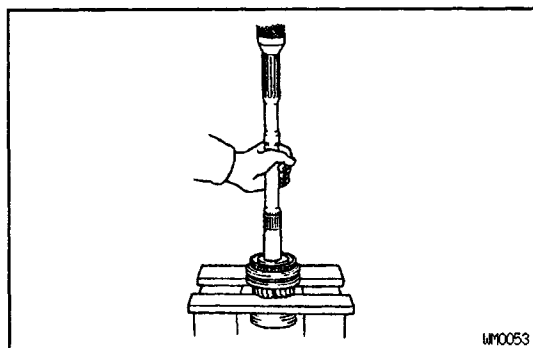

## 5. REMOVE NO.1 HUB SLEEVE ASSEMBLY, SECOND GEAR AND NEEDLE ROLLER BEARING

Using a press, remove the parts from the shaft as an assembly.

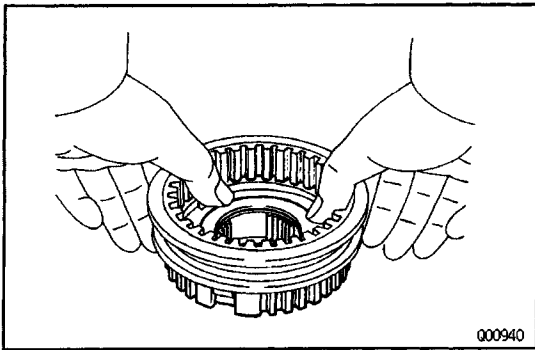

**6. REMOVE NO.1 HUB SLEEVE, SHIFTING KEYS AND SPRINGS FROM CLUTCH HUB NO.1**

(a) Remove the No. 1 clutch hub from the No. 1 hub sleeve.

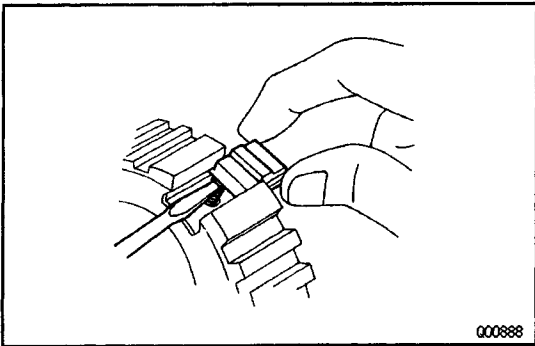

(b) Push the shifting key spring with screwdriver, remove the three shifting keys and key springs.

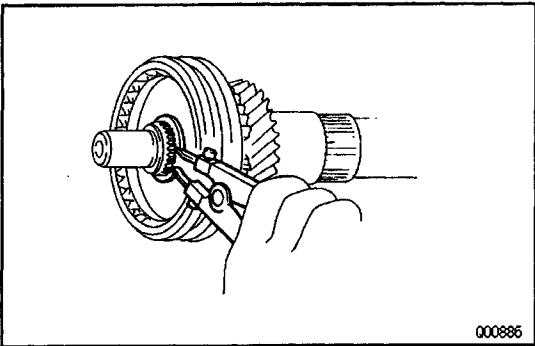

**7. REMOVE NO. 2 HUB SLEEVE ASSEMBLY AND THIRD GEAR**

(a) Using a snap ring expander, remove the snap ring.

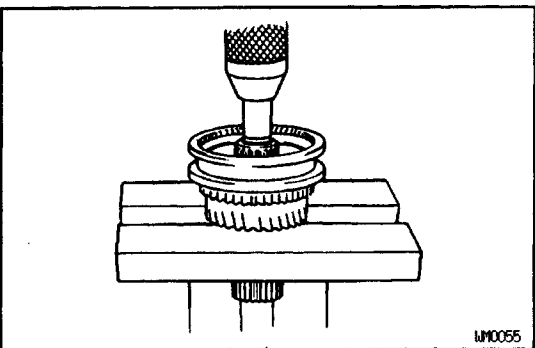

(b) Using a press, remove the No.2 hub sleeve, synchronizer ring and 3rd gear.

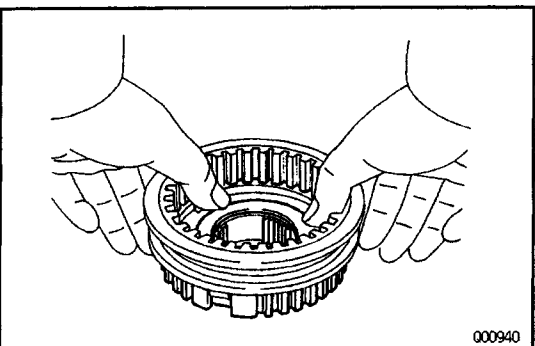

**8. REMOVE NO.2 HUB SLEEVE, SHIFTING KEYS AND SPRINGS FROM NO.2 CLUTCH HUB**

(a) Remove the No. 2 hub sleeve from the No. 2 hub sleeve.

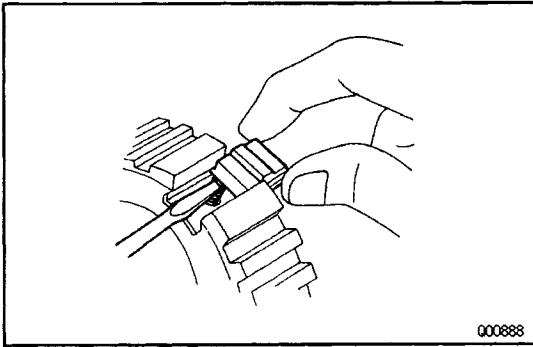

- (b) Push the shifting key spring with screwdriver, remove the three shifting keys and key springs.

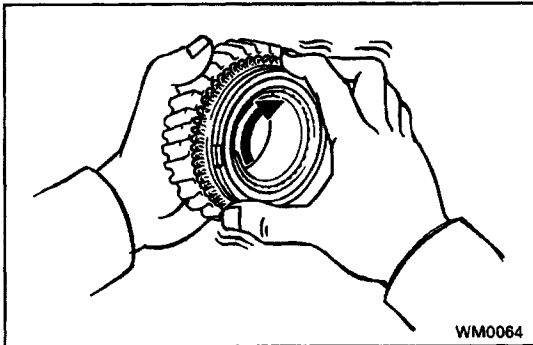

## OUTPUT SHAFT COMPONENT PARTS INSPECTION

### 1. INSPECT SYNCHRONIZER RINGS

- (a) Check for wear or damage.
- (b) Check the braking effect of the synchronizer ring. Turn the synchronizer ring in one direction while pushing it to the gear cone and check that the ring is locked. If the braking effect is insufficient, lightly rub the synchronizer ring and gear cone by applying a small amount of fine lapping compound.

#### NOTICE:

- Wash off completely the fine lapping compound after rubbing.
  - Check again the braking effect of the synchronizer ring.
- (c) Using a feeler gauge, measure the clearance between the synchronizer ring back and the gear spline end.

#### Minimum clearance:

**0.5 mm (0.020 in.)**

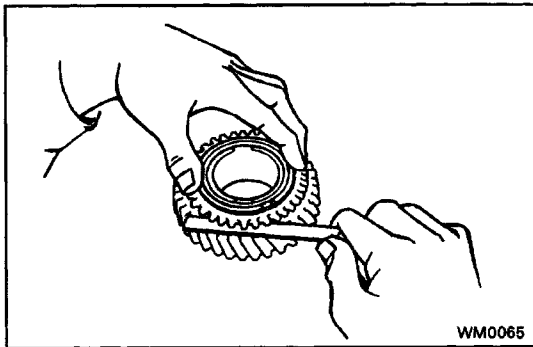

#### HINT:

- When replacing either a synchronizer ring or gear, apply a small amount of fine lapping compound between the synchronizer ring and gear cone. Lightly rub the synchronizer ring and gear together.
- When replacing both the synchronizer ring and gear, there is no need to apply any compound or to rub them together.

NOTICE: Wash off completely the fine lapping compound after rubbing.

### 2. INSPECT CLEARANCE OF SHIFT FORKS AND HUB SLEEVES

Using a feeler gauge, measure the clearance between the hub sleeve and shift fork.

#### Minimum clearance:

**1.0 mm (0.039 in.)**

If the clearance exceeds the maximum, replace the shift fork or hub sleeve.

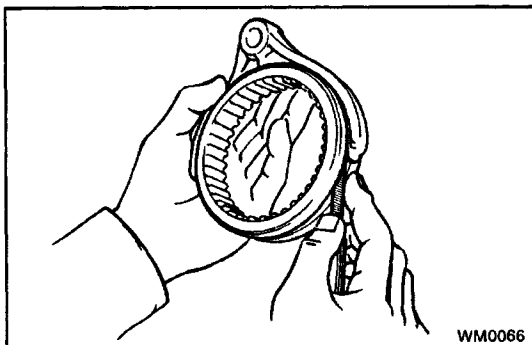

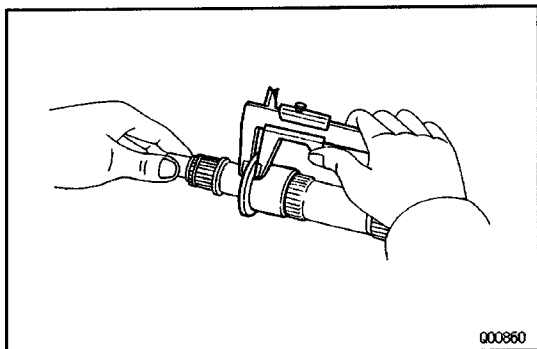

### 3. INSPECT OUTPUT SHAFT AND INNER RACE

- (a) Using vernier calipers, measure the output shaft flange thickness.

**Minimum thickness:**

**5.60 mm (0.2204 in.)**

If the thickness exceeds the minimum, replace the output shaft.

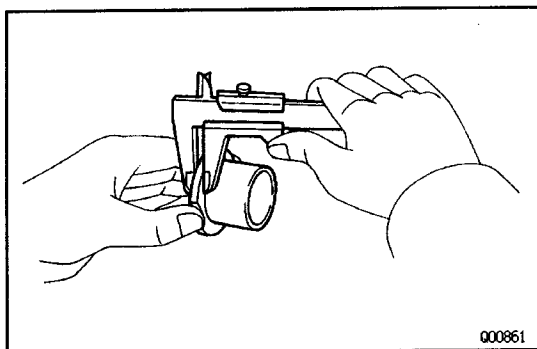

- (b) Using vernier calipers, measure the inner race flange thickness.

**Minimum thickness:**

**4.78 mm (0.1882 in.)**

If the thickness exceeds the minimum, replace the inner race.

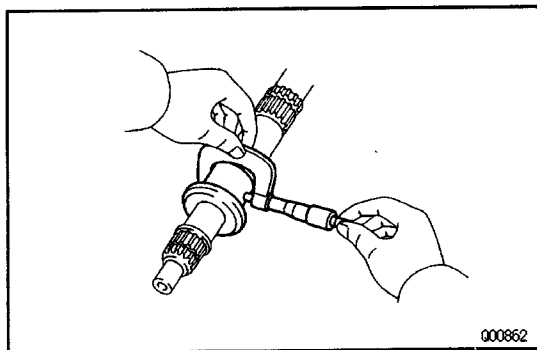

- (c) Using a micrometer, measure the outer diameter of the output shaft journal.

Minimum diameter:

**2nd gear**

**42.975 mm (1.6919 in.)**

**3rd gear**

**31.969 mm (1.2586 in.)**

If the outer diameter exceeds the minimum, replace the output shaft.

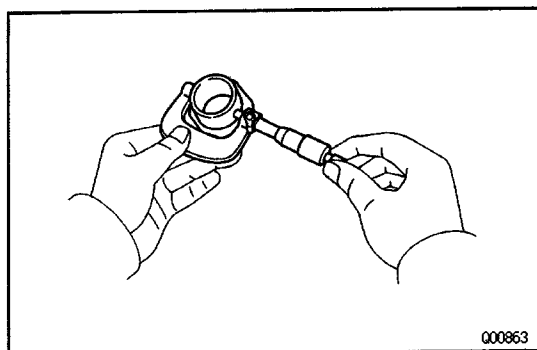

- (d) Using a micrometer, measure the outer diameter of the inner race.

**Minimum diameter:**

**42.975 mm (1.6919 in.)**

If the outer diameter exceeds the minimum, replace the inner race.

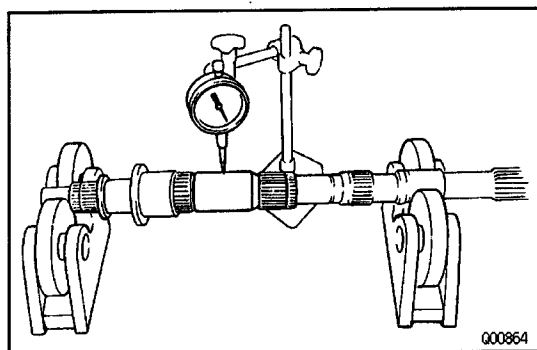

- (e) Using a dial indicator, check the shaft runout.

**Maximum runout:**

**0.06 mm (0.0024 in.)**

If the runout exceeds the maximum, replace the output shaft.

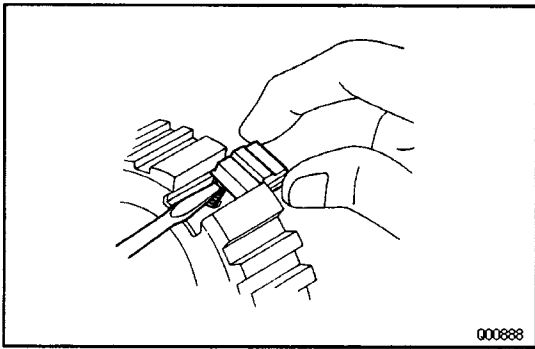

## OUTPUT SHAFT ASSEMBLY

HINT: Coat all of the sliding and rotating surface with gear oil before assembly.

### 1. INSTALL NO.1 AND NO.2 CLUTCH HUB INTO HUB SLEEVE

- (a) Install the three shifting key springs to the clutch hub.
- (b) While pushing the shifting key spring with screwdriver, install the three shifting keys.
- (c) While pushing the three shifting keys, install the clutch hub to the hub sleeve.

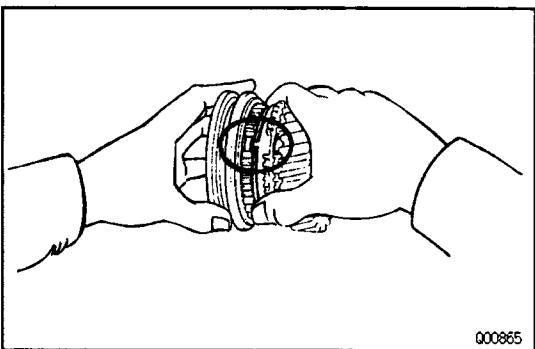
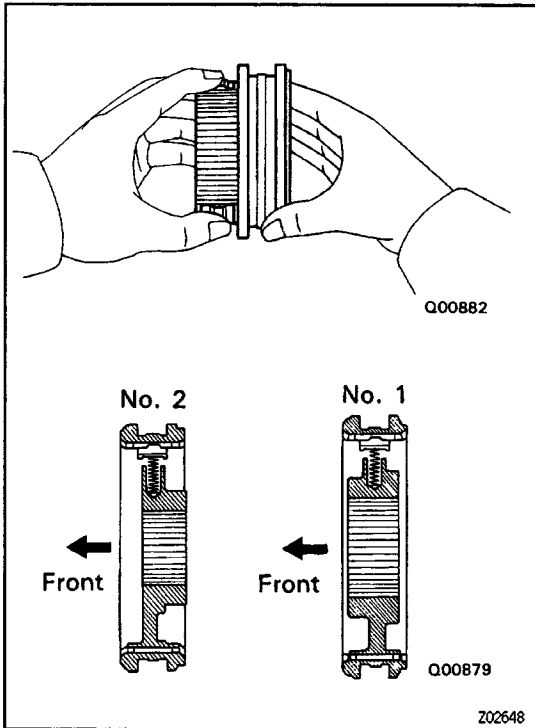

### 2. INSTALL THIRD GEAR AND NO.2 CLUTCH HUB ON OUTPUT SHAFT

- (a) Apply gear oil to the shaft.
- (b) Place the synchronizer ring on the gear and align the ring slots with the shifting keys.

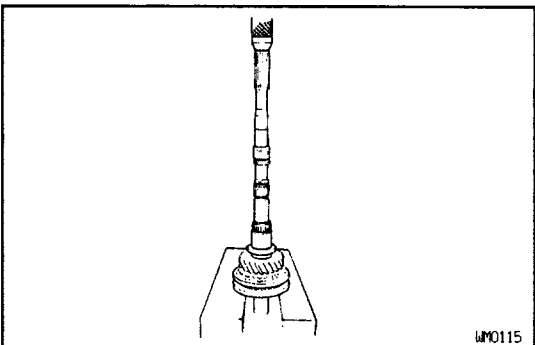

- (c) Using a press, install the 3rd gear and No.2 clutch hub.

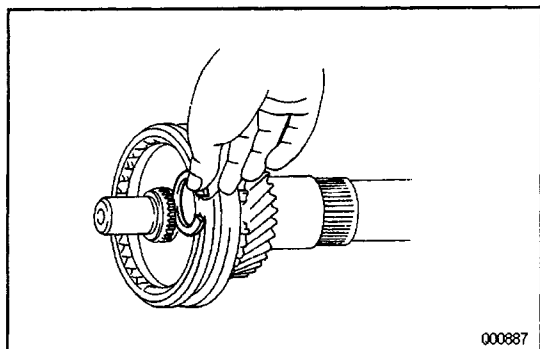

### 3. INSTALL SNAP RING

(a) Select a snap ring that will allow minimum axial play.

Mark	Thickness mm (in.)
C-1	1.75-1.80 (0.0689-0.0709)
D	1.80-1.85 (0.0709-0.0728)
11	1.86-1.91 (0.0732-0.0752)
12	1.92-1.97 (0.0756-0.0776)
13	1.98-2.03 (0.0780-0.0799)
14	2.04-2.09 (0.0803-0.0823)
15	2.10-2.15 (0.0827-0.0846)

(b) Using a snap ring expander, install the snap ring.

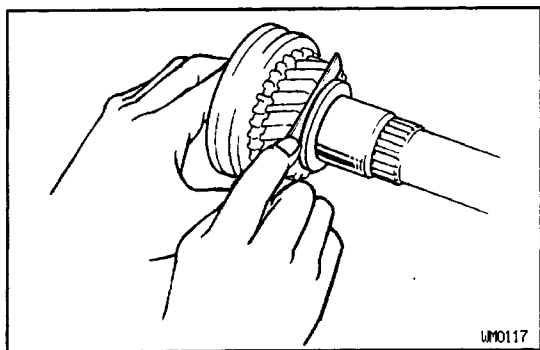
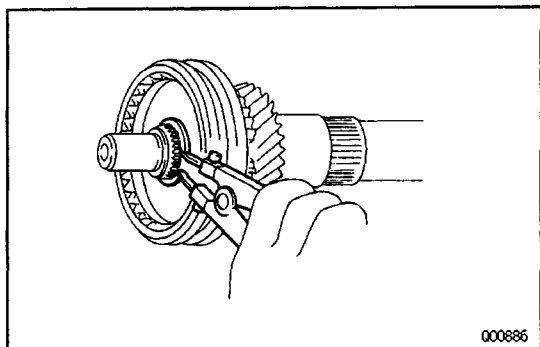

### 4. INSPECT THIRD GEAR THRUST CLEARANCE

Using a feeler gauge, measure the 3rd gear thrust clearance.

**Standard clearance:**

**0.10-0.25 mm (0.0039-0.0098 in.)**

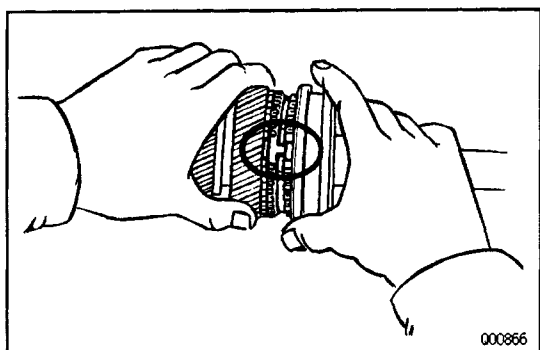

### 5. INSTALL SECOND GEAR AND NO.1 CLUTCH HUB

- Apply gear oil to the shaft and needle roller bearing.
- Place the synchronizer ring on the gear and align the ring slots with the shifting keys.
- Install the needle roller bearing in the 2nd gear.

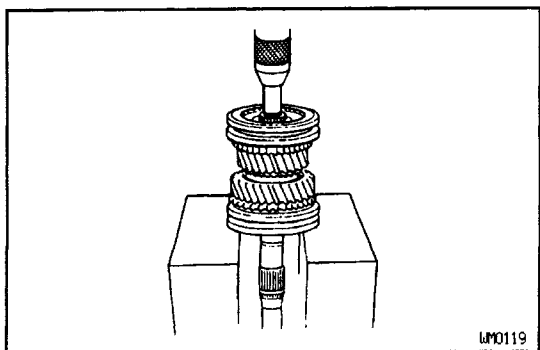

(d) Using a press, install the 2nd gear and No.1 clutch hub.



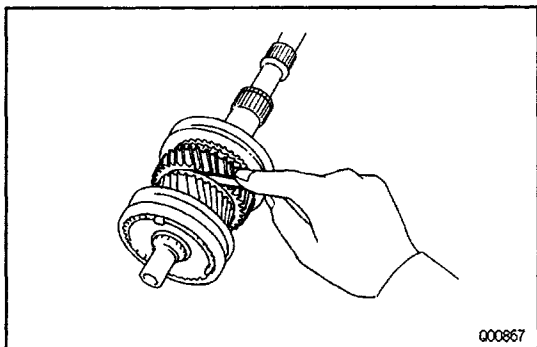

## 6. INSPECT SECOND GEAR THRUST CLEARANCE

Using a feeler gauge, measure the 2nd gear thrust clearance.

**Standard clearance:**

**0.10–0.25 mm (0.0039–0.0098 in.)**

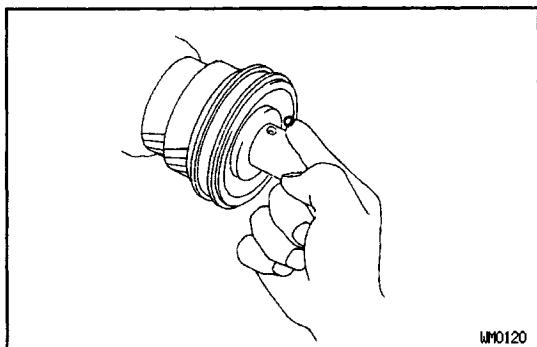

## 7. INSTALL LOCKING BALL AND FIRST GEAR ASSEMBLY

(a) Install the locking ball in the shaft.

(b) Apply gear oil to the bearing.

(c) Assemble the 1st gear, synchronizer ring, needle roller bearing and bearing inner race.

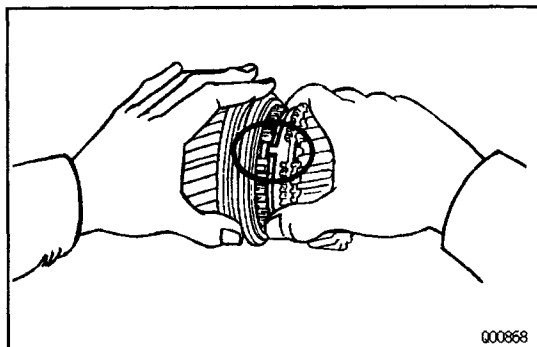

(d) Install the assembly on the output shaft with the synchronizer ring slots aligned with the shifting keys and turn the inner race to align it with the locking ball.

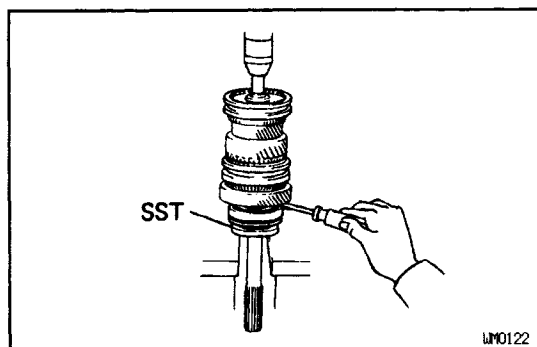

## 8. INSTALL OUTPUT SHAFT CENTER BEARING

Using SST and a press, install the bearing on the output shaft with the outer race snap ring groove toward the rear.

HINT: Hold the 1st gear inner race to prevent it from falling.

SST 09506 -35010

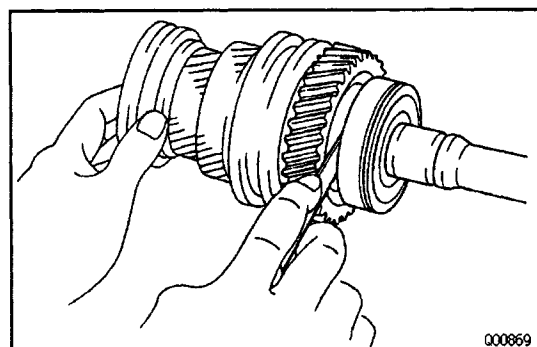

## 9. INSPECT FIRST GEAR THRUST CLEARANCE

Using a feeler gauge, measure the 1st gear thrust clearance.

**Standard clearance:**

**0.10–0.25 mm (0.0039–0.0098 in.)**

# COUNTER GEAR AND REVERSE IDLER GEAR COMPONENTS

MT00N-02

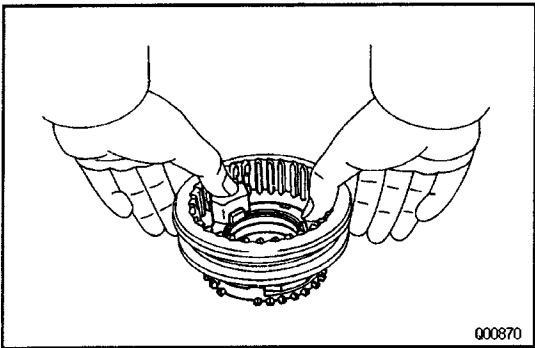
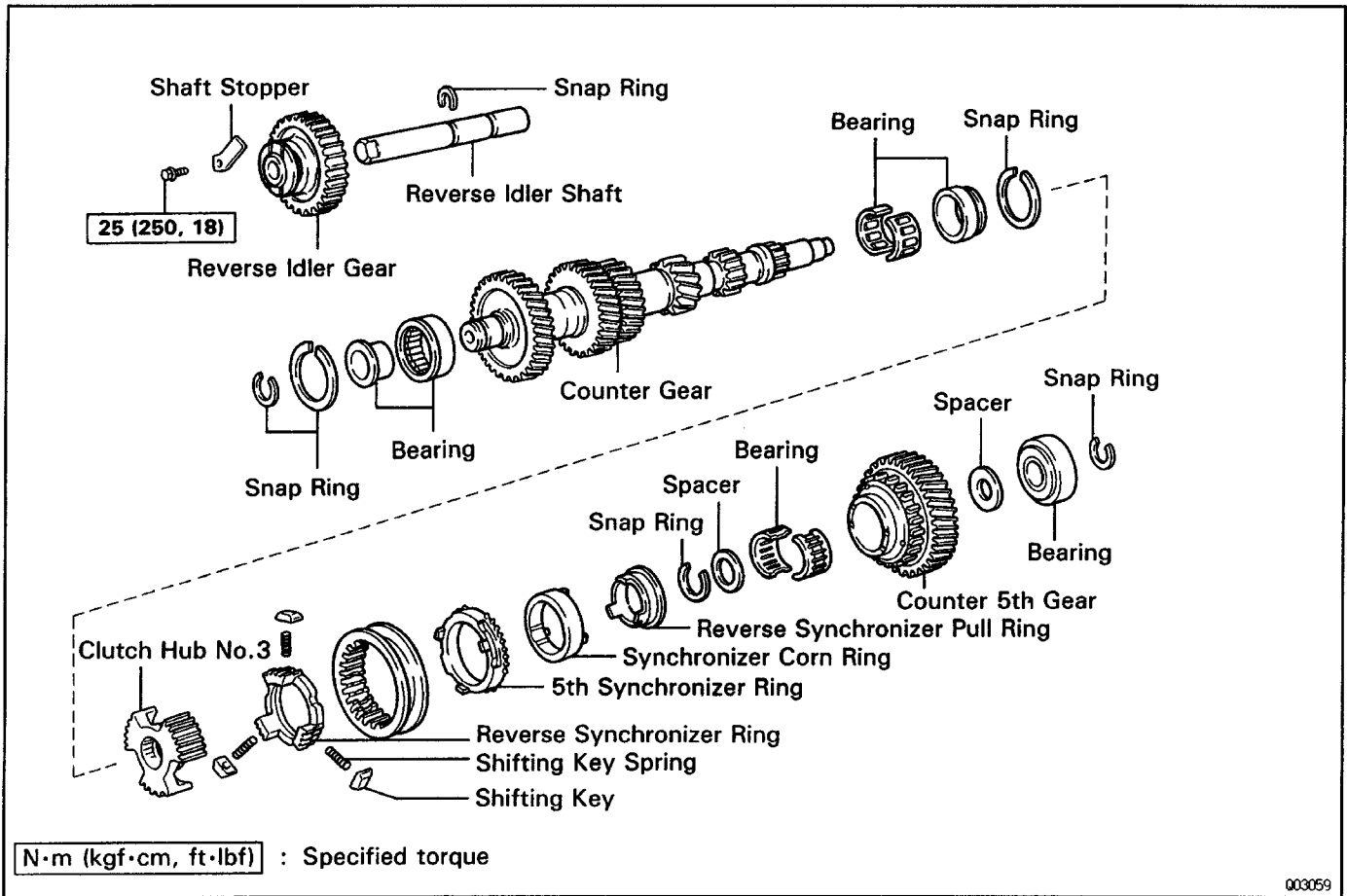

## COUNTER GEAR COMPONENT PARTS DISASSEMBLY

MT00P-02

### 1. REMOVE NO.3 HUB SLEEVE, SHIFTING KEYS AND SPRINGS FROM SYNCHRONIZER RING

(a) Remove the synchronizer ring assembly from No.3 hub sleeve.

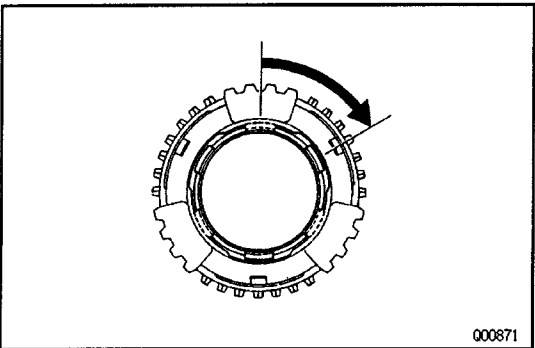

(b) Turn the reverse synchronizer pull ring.

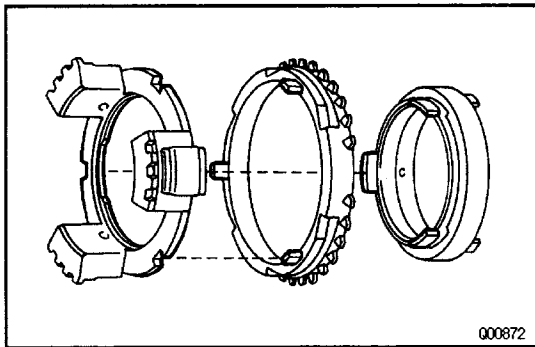

- (c) Remove the reverse synchronizer ring and 5th synchronizer ring.

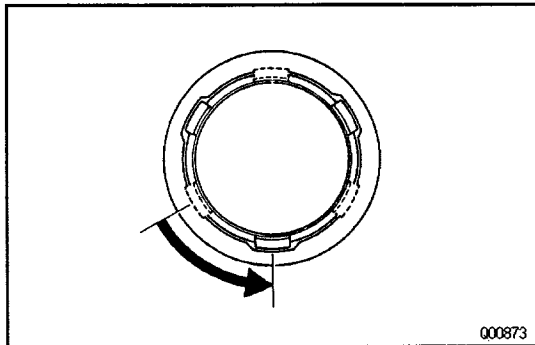

- (d) Turn the reverse synchronizer pull ring, separate pull ring and cone ring.

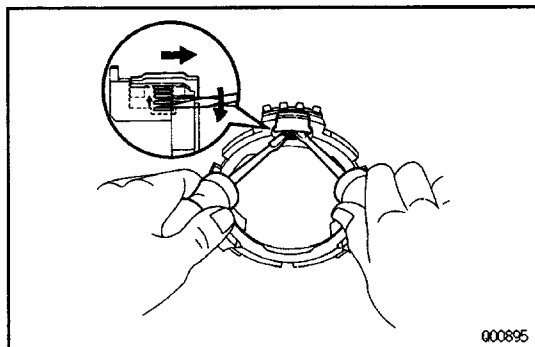

- (e) While pushing the shifting key spring to out slide with two screwdrivers, remove the shifting keys and key springs, from remove synchronizer ring.

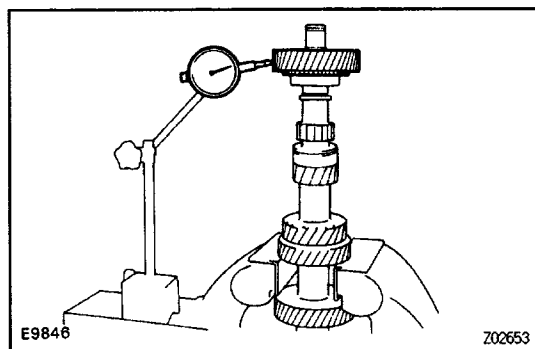

## COUNTER GEAR AND REVERSE IDLER GEAR COMPONENT PARTS INSPECTION

### 1. INSPECT COUNTER 5TH GEAR OIL CLEARANCE

- (a) Install the spacer, counter 5th gear and needle roller bearing to counter gear.  
 (b) Using a dial indicator, measure the counter 5th gear oil clearance.

**Standard clearance:**

**0.009–0.06 mm (0.0004–0.0024 in.)**

**Maximum clearance:**

**0.15 mm (0.0059 in.)**

If the clearance exceeds the maximum, replace the counter gear or needle roller bearing or counter 5th gear.

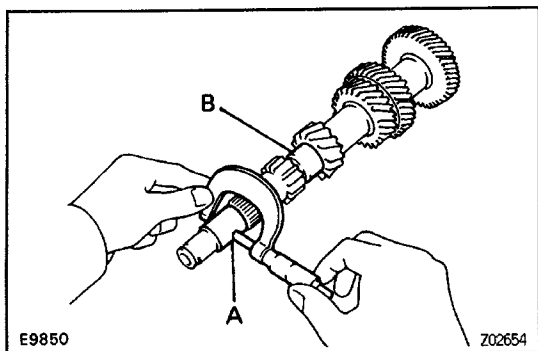

## 2. INSPECT COUNTER GEAR

Using a micrometer, measure the outer diameter of the counter shaft journal.

**Minimum diameter:**

**Part A**

26.975 mm (1.0620 in.)

**Part B**

29.95 mm (1.1791 in.)

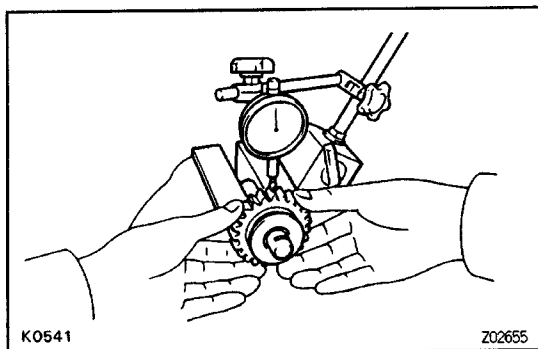

## 3. INSPECT REVERSE IDLER GEAR OIL CLEARANCE

Using a dial indicator, measure the reverse idler gear oil clearance.

**Standard clearance:**

0.041–0.074 mm (0.0016–0.0029 in.)

**Maximum clearance:**

0.194 mm (0.0076 in.)

If the clearance exceeds the maximum, replace the gear or shaft.

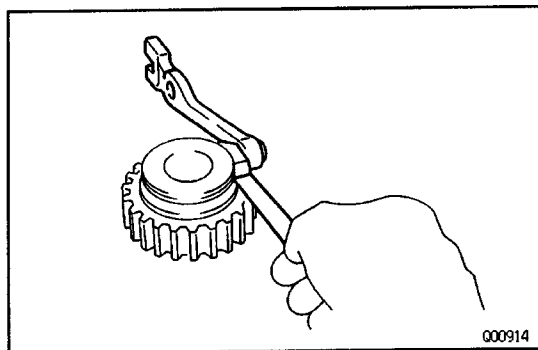

## 4. INSPECT CLEARANCE OF REVERSE IDLER GEAR AND SHIFT ARM SHOE

Using a feeler gauge, measure the clearance between the reverse idler gear and shift arm shoe.

**Standard clearance:**

0.20–0.41 mm (0.008–0.0161 in.)

**Maximum clearance:**

0.9 mm (0.0354 in.)

If the clearance exceeds the maximum, replace the shift arm shoe or reverse idler gear.

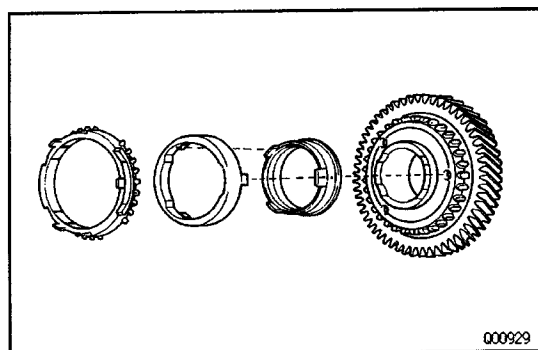

## 5. INSPECT FIFTH SYNCHRONIZER RING

(a) Check for wear or damage.

(b) Install the synchronizer pull ring, corn ring and outer ring to 5th gear.

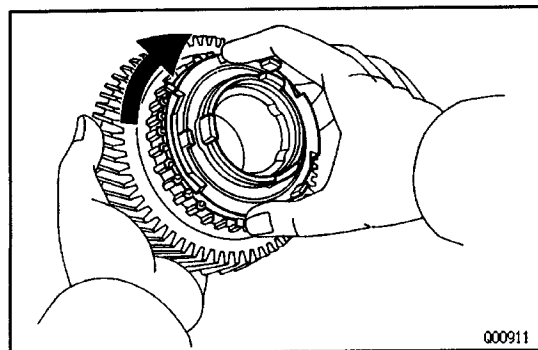

(c) Check the braking effect of the synchronizer ring.

Turn the synchronizer ring in one direction while pushing it to the gear cone and check that the ring is locked.

If the backing effect is insufficient, replace the synchronizer rings.

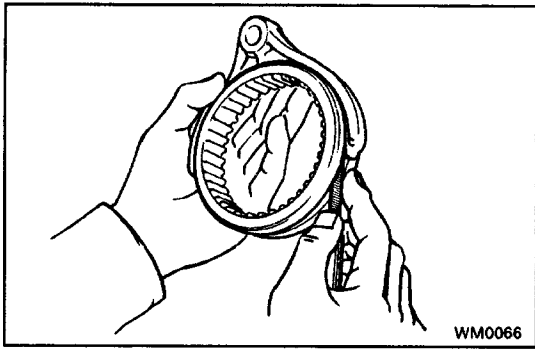

## 6. INSPECT CLEARANCE OF SHIFT FORKS AND HUB SLEEVES

Using a feeler gauge, measure the clearance between the hub sleeve and shift fork.

**Maximum clearance:**

**1.0 mm (0.039 in.)**

If the clearance exceeds the maximum, replace the shift fork or hub sleeve.

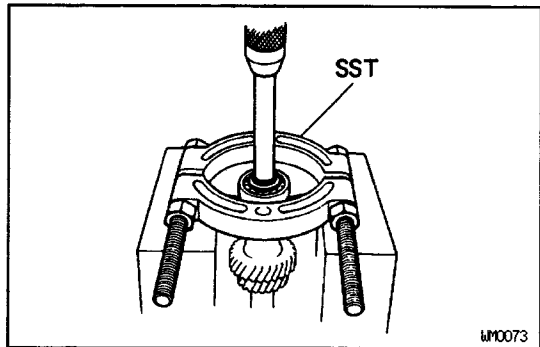

## BEARING REPLACEMENT

MT00R-02

### 1. IF NECESSARY, REPLACE COUNTER GEAR FRONT BEARING AND SIDE RACE

(a) Using snap ring pliers, remove the snap ring.

(b) Using SST, press out the bearing.

SST 09950-00020

(c) Check the side race for wear or damage.

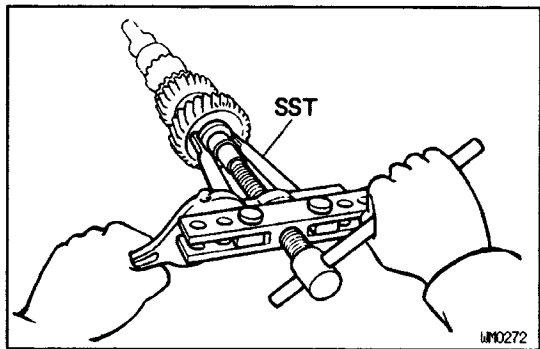

(d) If necessary, remove the side race.

Using SST and socket wrench, remove the side race.

SST 09950-20017

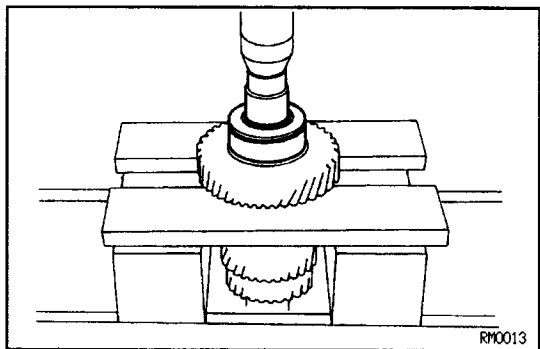

(e) Using a socket wrench, press in a new bearing, side race and inner race.

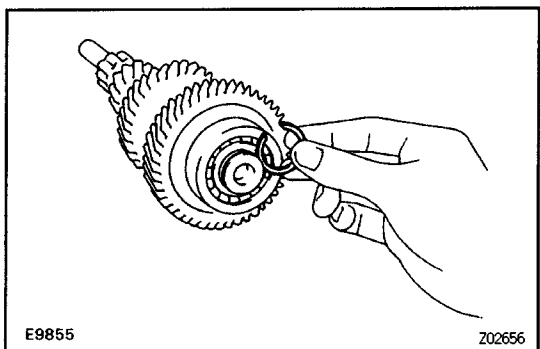

(f) Select a snap ring that will allow minimum axial play.

Mark	Thickness mm (in.)
A	2.05-2.10 (0.0807-0.0827)
B	2.10-2.15 (0.0827-0.0846)
C	2.15-2.20 (0.0846-0.0866)
D	2.20-2.25 (0.0866-0.0886)
E	2.25-2.30 (0.0886-0.0906)
F	2.30-2.35 (0.0906-0.0925)

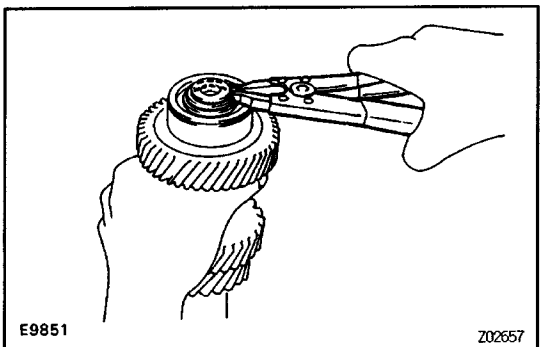

(g) Using a snap ring expander, install the snap ring.

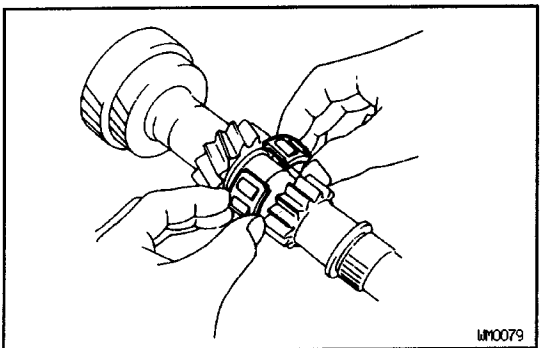

**2. IF NECESSARY, REPLACE COUNTER GEAR CENTER BEARING**

- (a) Remove the bearing from the counter gear.
- (b) Install a new bearing on the counter gear.

HINT: Engage the roller cages.

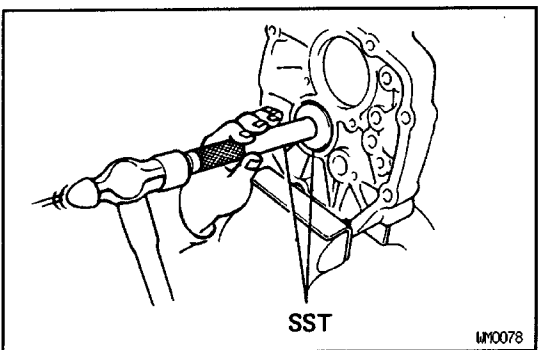

(c) Using SST, tap out the bearing outer race.

SST 09608-35014 (09608-06020, 09608-06090)

HINT: The outer race will be installed later, as the transmission is assembled.

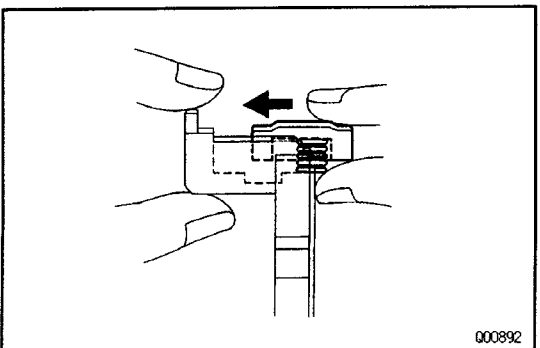

**COUNTER GEAR COMPONENT PARTS ASSEMBLY**

**1. INSTALL SYNCHRONIZER RING ASSEMBLY TO NO.3 HUB SLEEVE**

- (a) Push the synchronizer spring, install the shifting key and key spring to reverse synchronizer ring.

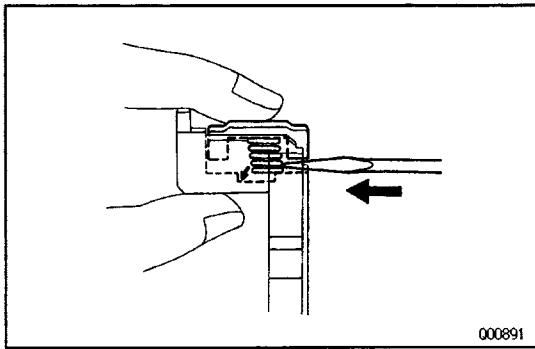

(b) Using a screwdriver, push the three key springs into the synchronizer ring spring gear.

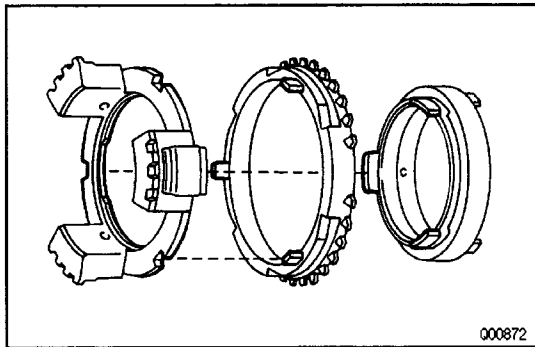

(c) Install the synchronizer corn ring to reverse synchronizer pull ring.

(d) Install the 5th synchronizer ring.

(e) Install the reverse synchronizer ring.

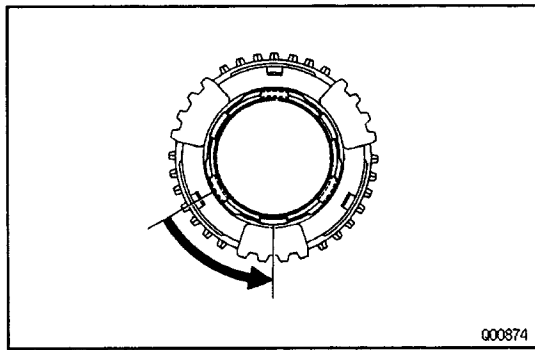

(f) Turn the reverse synchronizer pull ring.

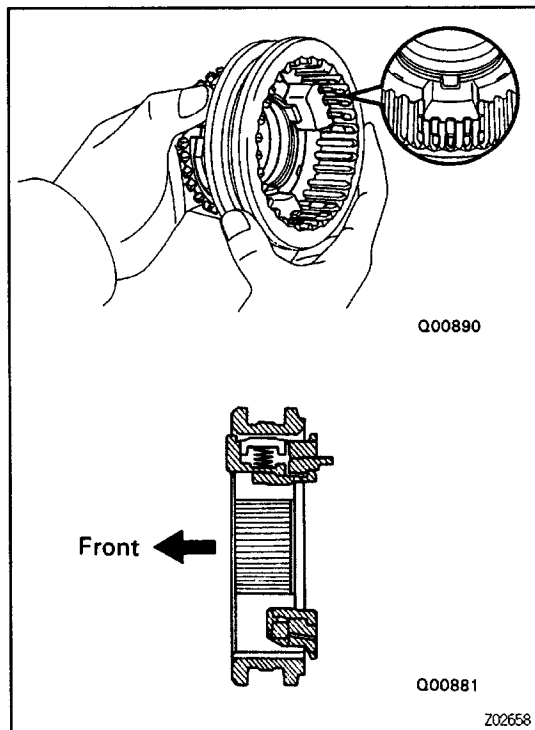

(g) While pushing three shifting keys, install the synchronizer ring assembly to No.3 hub sleeve.

# FRONT BEARING RETAINER COMPONENT

MT00T-01

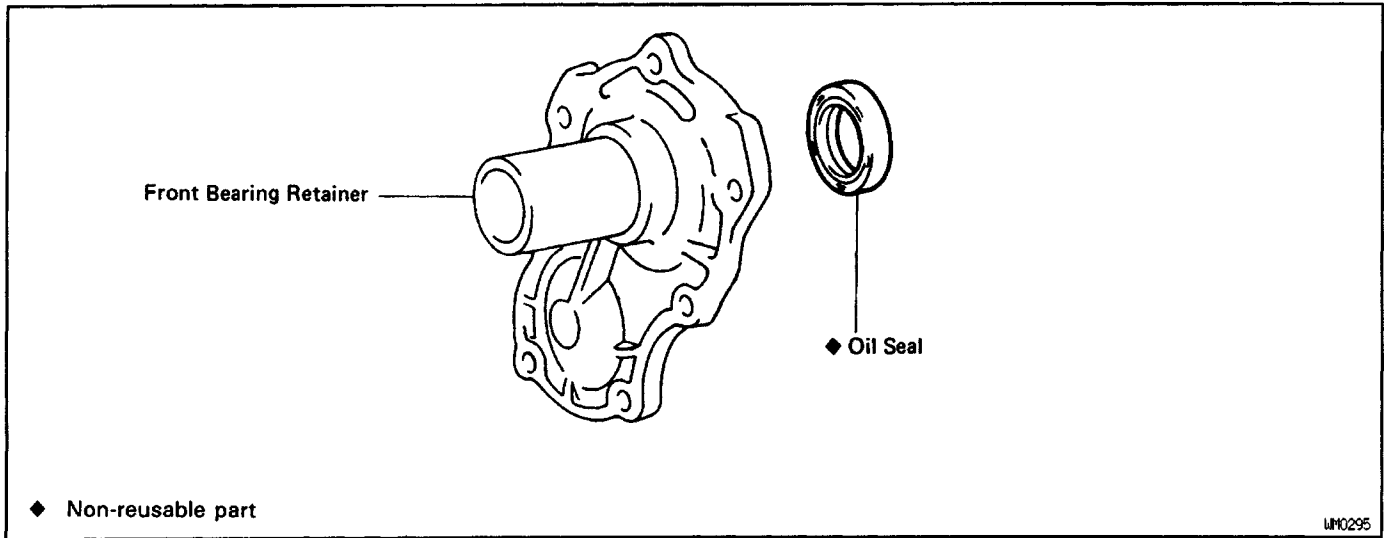

MT00U-02

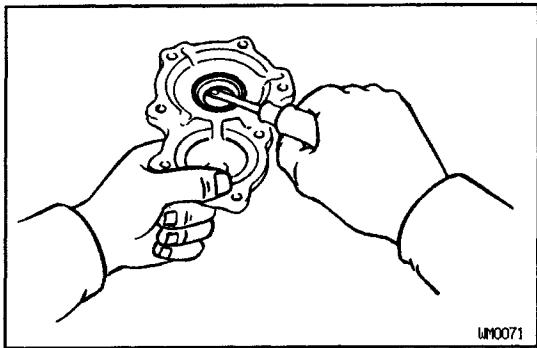

## OIL SEAL REPLACEMENT

IF NECESSARY, REPLACE FRONT BEARING RETAINER OIL SEAL

(a) Using a screwdriver, pry out the oil seal.

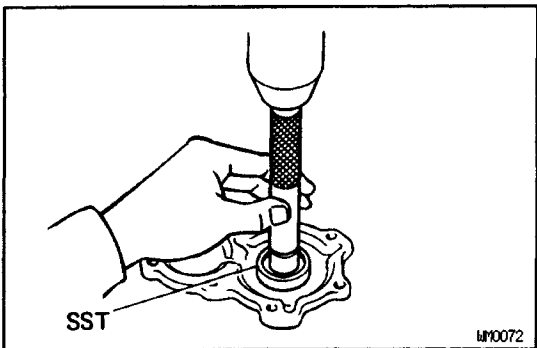

(b) Using SST and a press, install a new oil seal.

SST 09608-20012 (09608-03020, 09608-00080)

**Drive in depth:**

**11.4-12.0 mm (0.449-0.472 in.) from retainer.**



# EXTENSION HOUSING AND TRANSFER ADAPTOR COMPONENT

MT00V-02

**2WD**

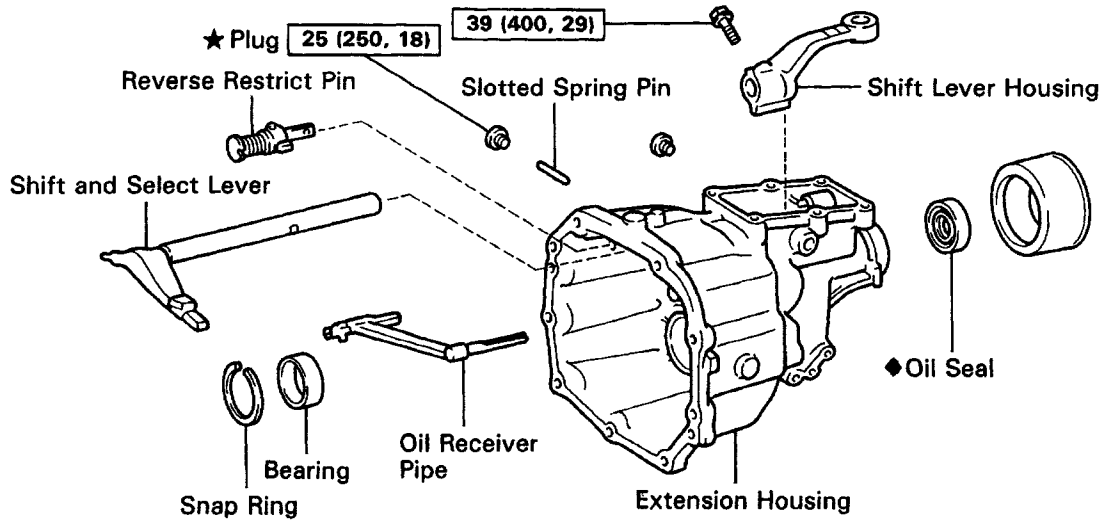

**4WD**

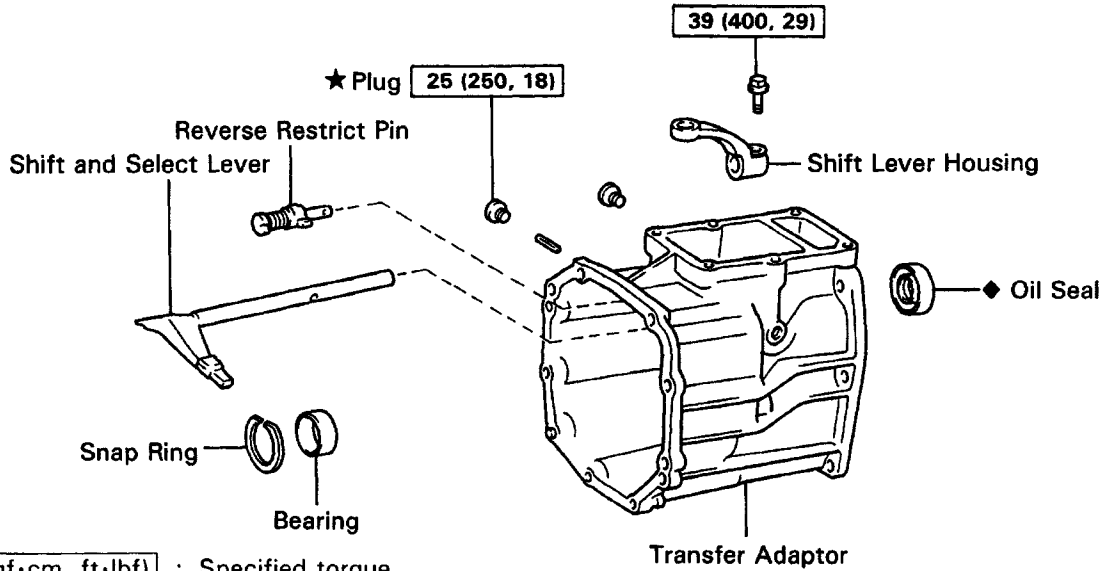

**N·m (kgf·cm, ft·lbf)** : Specified torque

◆ Non-reusable part

★ Precoated part

Q01564  
WM0316

Z04680

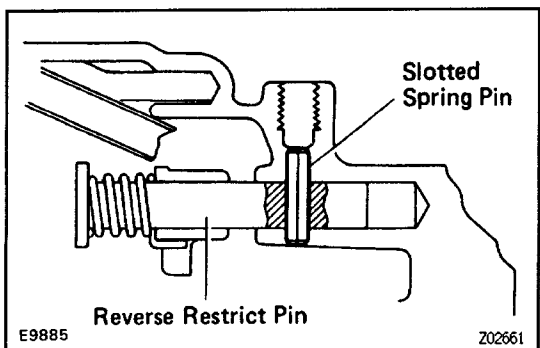
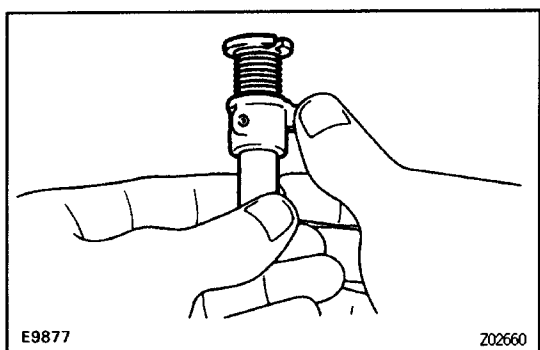
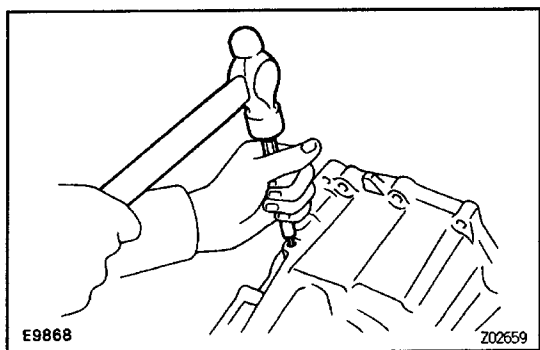
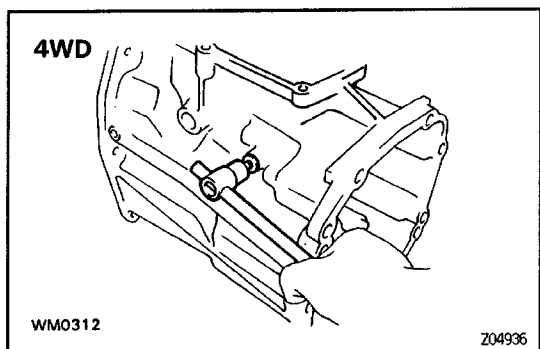
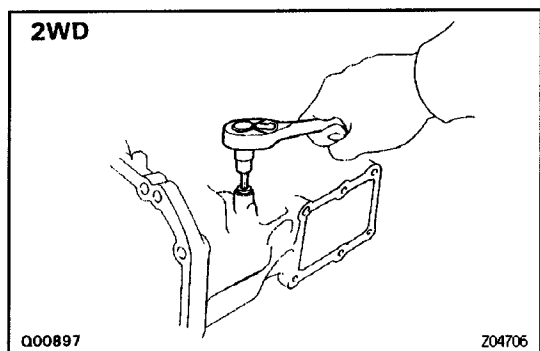

MT01-01

## REVERSE RESTRICT PIN REPLACEMENT

### 1. REMOVE REVERSE RESTRICT PIN

(a) Using a hexagon wrench, remove the screw plug.

(b) Using a pin punch and hammer, drive out the slotted spring pin.

(c) Pull off the lever housing and slide out the shaft.

### 2. INSPECT REVERSE RESTRICT PIN

Turn and push the reverse restrict pin by hand while applying direction.

### 3. INSTALL REVERSE RESTRICT PIN

(a) Install the lever housing.

(b) Using a pin punch and hammer, drive in the slotted spring pin as shown.

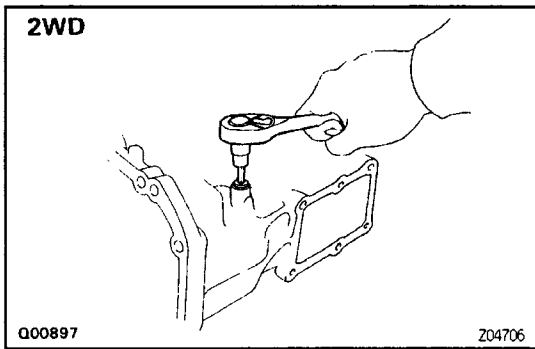

(c) Apply liquid sealer to the plug.

**Sealant:**

**Part No. 08833-00080, THREE BOND 7344, LOC-TITE 242 or equivalent**

(d) install and torque the screw plug.

**Torque: 25 N-m (250 kgf-cm, 18 ft-lbf)**

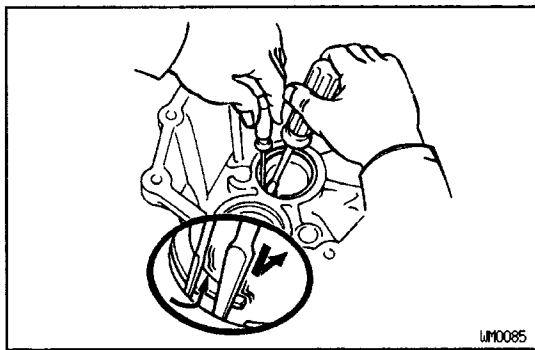
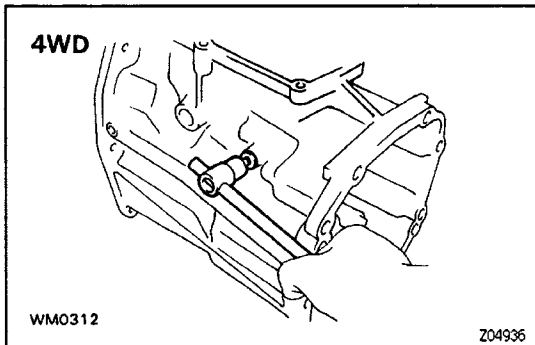

**BEARING REPLACEMENT**

MT00X-02

**IF NECESSARY, REPLACE REAR BEARING OUT REAR RACE**

(a) Using two screwdrivers, remove the snap ring.

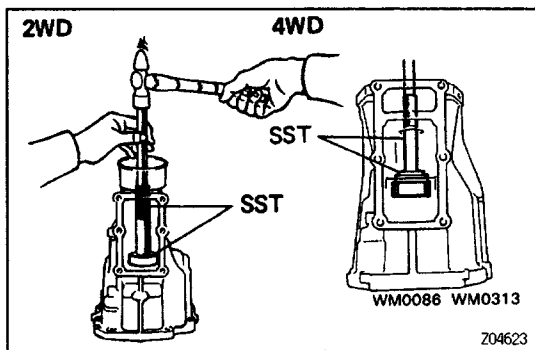

(b) Using SST and a hammer, tap out the outer race.

SST 09608-12010 (09608-00020, 09608-00050)

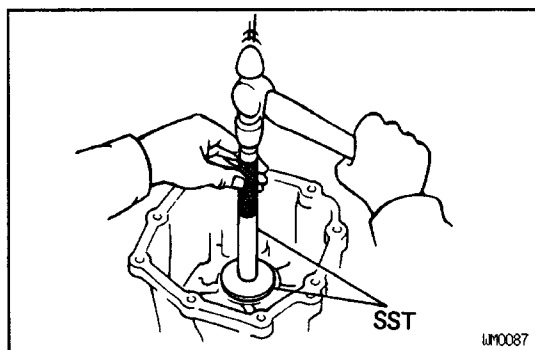

(c) Using SST, install a new outer race.

SST 09608-35014 (09608-06020, 09608-06100)

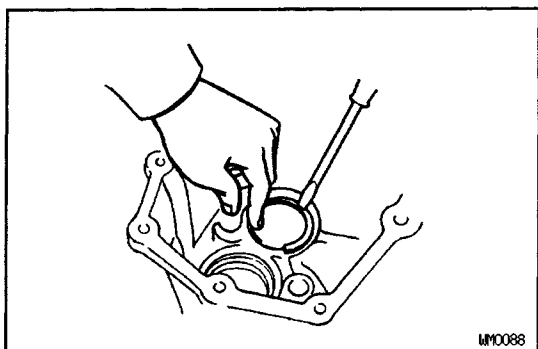

(d) Using a screwdriver, install the snap ring.

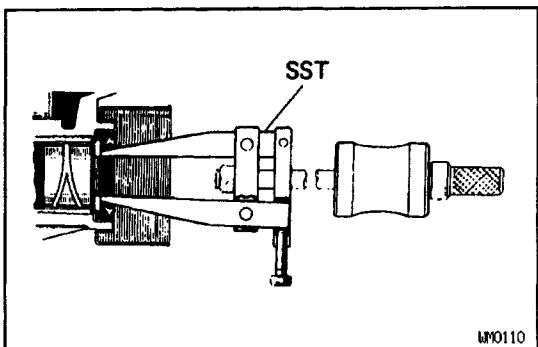

## OIL SEAL REPLACEMENT

(2WD)

IF NECESSARY, REPLACE EXTENSION HOUSING OIL SEAL

- (a) Using SST, remove the oil seal.  
SST 09308-00010 or  
09308-10010  
(w/ output shaft installed)
- (b) Using SST, drive in a new oil seal.  
SST 09325-20010

MT094-01

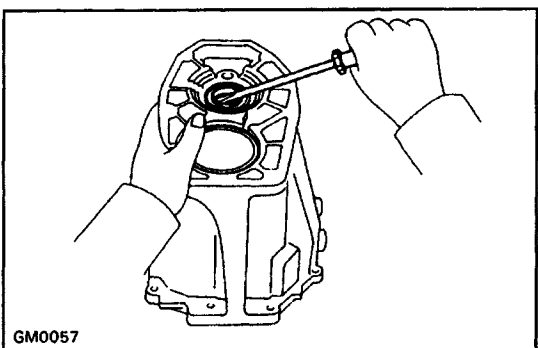
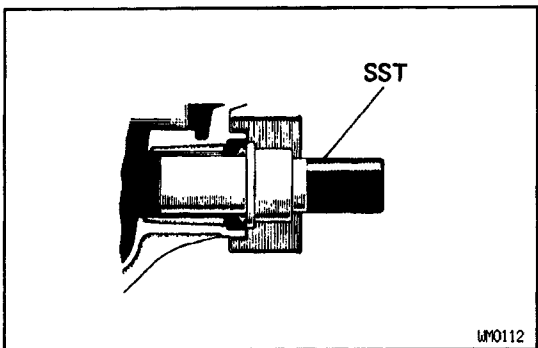

(4WD)

IF NECESSARY, REPLACE TRANSFER ADAPTOR OIL SEAL

- (a) Using a screwdriver, pry out the oil seal.

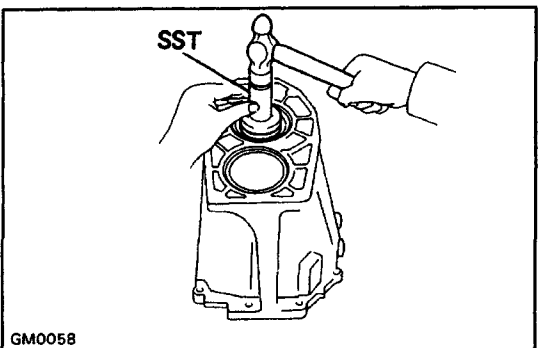

- (b) Using SST and a hammer, drive in a new oil seal.  
SST 09325-12010

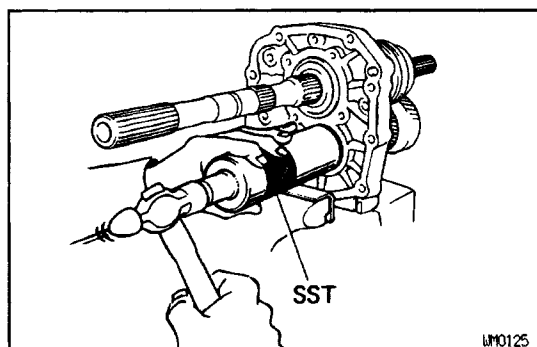
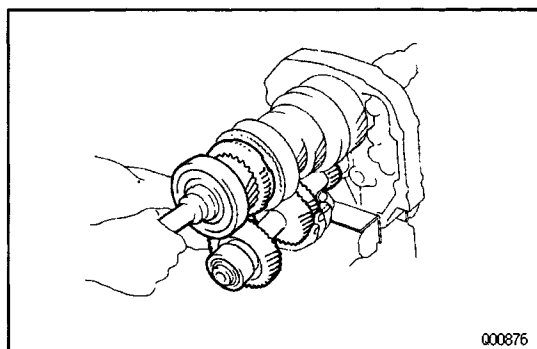
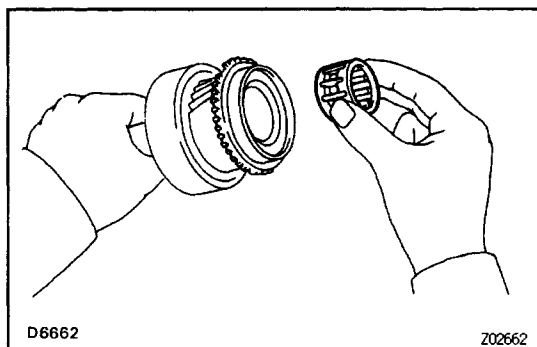
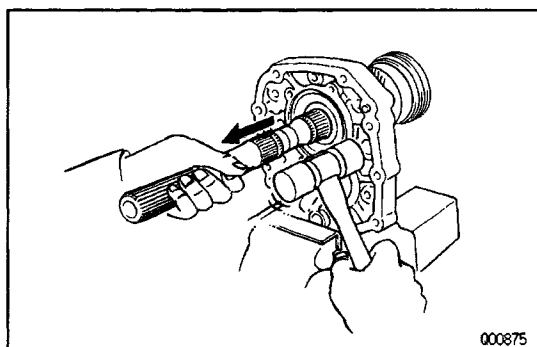
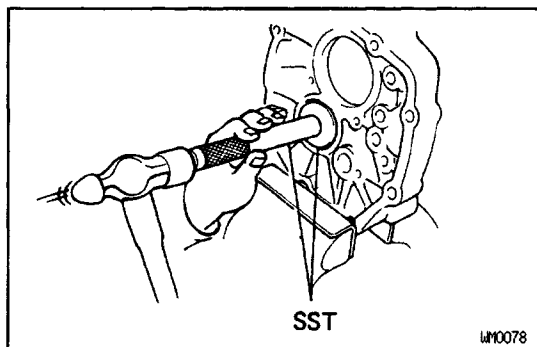

## COMPONENT PARTS INSTALLATION

### BASIC SUBASSEMBLY REASSEMBLY

HINT: Coat all of the sliding and rotating surface with gear oil before assembly.

#### 1. INSTALL OUTPUT SHAFT TO INTERMEDIATE PLATE

(a) Before installing the output shaft, use SST to remove the counter gear center bearing outer race.

SST 09608-35014 (09608-06020, 09608-06090)

HINT: Install the outer race after installing the counter gear.

(b) Install the output shaft into the intermediate plate by pulling on the output shaft and tapping on the intermediate plate.

#### 2. INSTALL INPUT SHAFT AND COUNTER GEAR

(a) Apply gear oil to the needle roller bearing.

(b) Install the needle roller bearing to the input shaft.

(c) Install the input shaft and counter gear together.

(d) Using SST and a hammer, install the counter gear center bearing outer race.

SST 09316-60010 (09316-00010)

HINT: Be careful not to damage the bearing rollers.

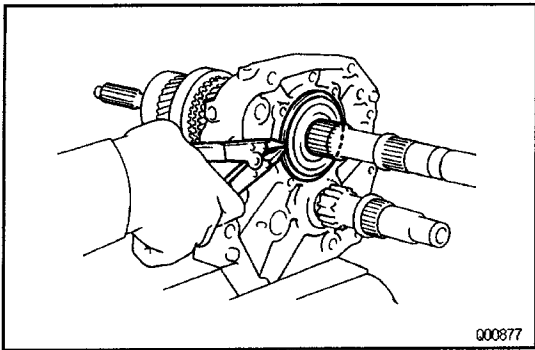

000877

### 3. INSTALL BEARING RETAINER

- (a) Using a snap ring expander, install the bearing snap ring.

HINT: Be sure the snap ring is flush with the intermediate plate surface.

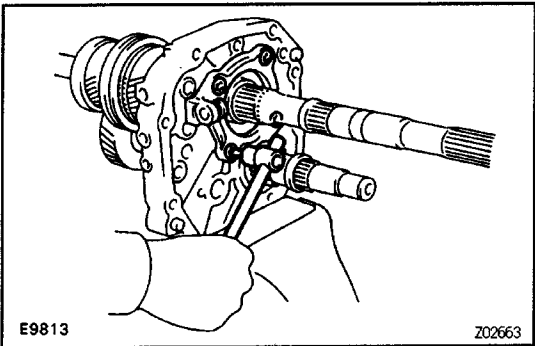

E9813

Z02663

- (b) Using a torx socket wrench, install and torque the screws.

Torx wrench T40 09042-00020

Torque: 18 N-m (185 kgf-cm, 13 ft-lbf)

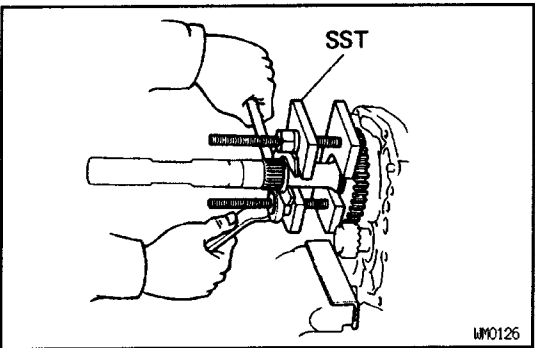

WM0126

### 4. INSTALL REVERSE GEAR

Using SST, install the reverse gear.

SST 09312-20011 (09313-00030, 09313-00040, 09313-00050)

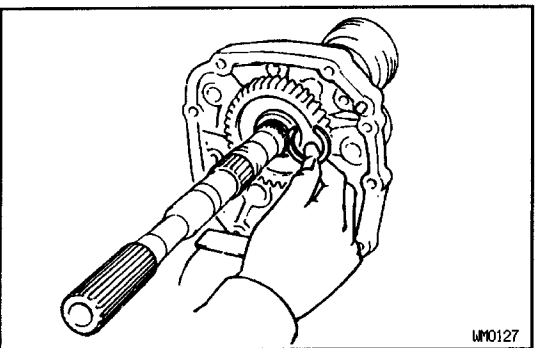

WM0127

### 5. INSTALL SNAP RING

- (a) Select a snap ring that will allow minimum axial play.

Mark	Thickness mm (in.)
5	2.25–2.30 (0.0886–0.0906)
11	2.30–2.35 (0.0906–0.0925)
12	2.35–2.40 (0.0925–0.0945)
13	2.40–2.45 (0.0945–0.0965)
14	2.45–2.50 (0.0965–0.0984)
15	2.50–2.55 (0.0984–0.1004)
16	2.55–2.60 (0.1004–0.1024)
17	2.61–2.66 (0.1028–0.1047)
18	2.67–2.72 (0.1051–0.1071)
19	2.73–2.78 (0.1075–0.1094)
20	2.79–2.84 (0.1098–0.1118)
21	2.85–2.90 (0.1122–0.1142)
22	2.91–2.96 (0.1146–0.1165)
23	2.97–3.02 (0.1169–0.1189)

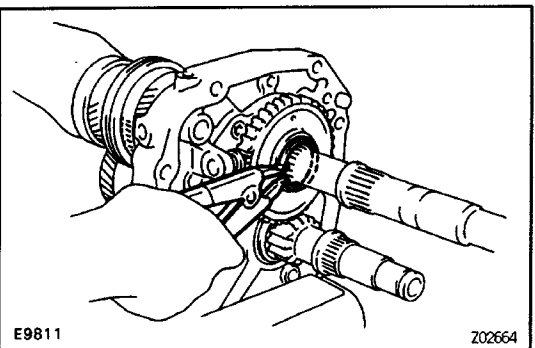

E9811

Z02664

- (b) Using a snap ring expander, install the snap ring.

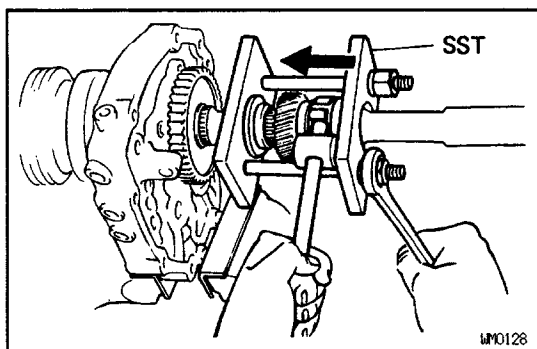

## 6. INSTALL FIFTH GEAR AND OUTPUT SHAFT REAR BEARING

Using SST, install the 5th gear and rear bearing. SST 09312-20011 (09313-00010, 09313-00030, 09313-00040, 09313-00050)

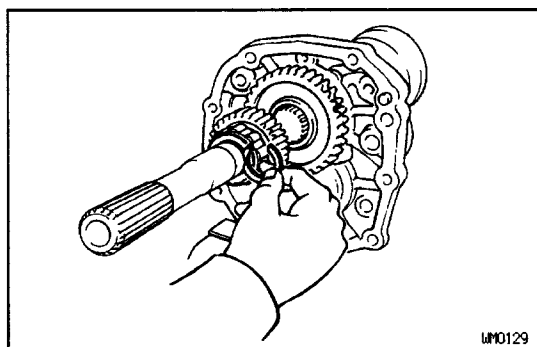

## 7. INSTALL SNAP RING

(a) Select a snap ring that will allow minimum axial play.

Mark	Thickness mm (in.)
8	2.31 – 2.36 (0.0909 – 0.0929)
9	2.37 – 2.42 (0.0933 – 0.0953)
10	2.43 – 2.48 (0.0957 – 0.0976)
11	2.49 – 2.54 (0.0980 – 0.1000)
12	2.55 – 2.60 (0.1004 – 0.1024)
13	2.61 – 2.66 (0.1028 – 0.1047)
14	2.68 – 2.73 (0.1055 – 0.1098)
15	2.74 – 2.79 (0.1079 – 0.1098)

(b) Using a screwdriver and hammer, tap in the snap ring.

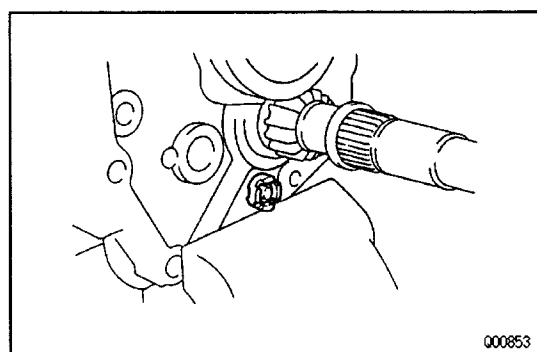
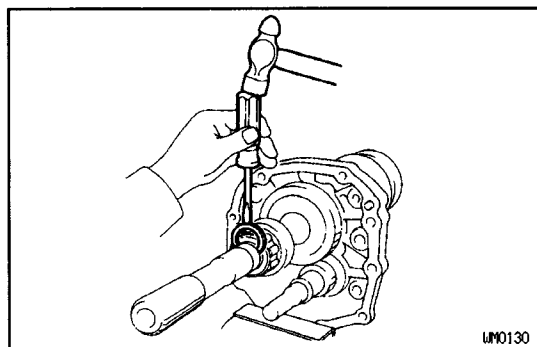

## 8. INSTALL REAR MAGNET

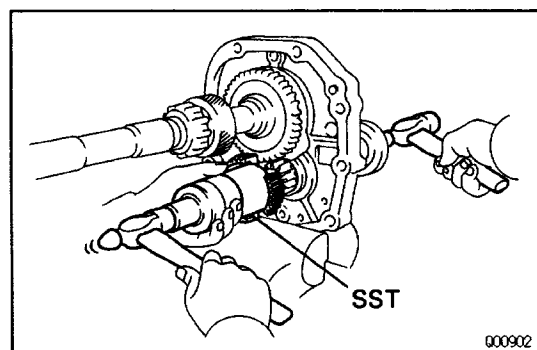

## 9. INSTALL NO.3 CLUTCH HUB

Using SST and a hammer, drive in No.3 clutch hub. SST 09316-60010 (09316-00010, 09316-00070)

HINT: When installing the clutch hub, support the counter shaft in front with a 3-5 lb hammer or equivalent.

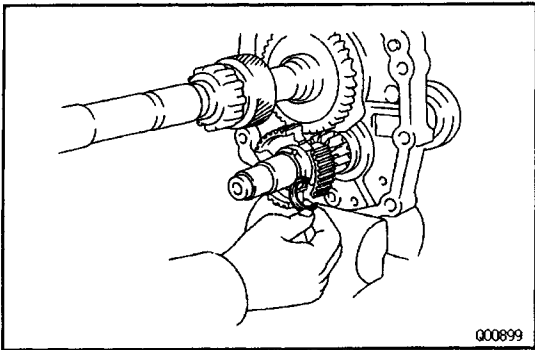

**10. INSTALL SNAP RING**

(a) Select a snap ring that will allow minimum axial play.

Mark	Thickness mm (in.)
2	2.06–2.11 (0.0811–0.0831)
3	2.12–2.17 (0.0835–0.0854)
4	2.18–2.23 (0.0858–0.0878)
5	2.24–2.29 (0.0882–0.0902)

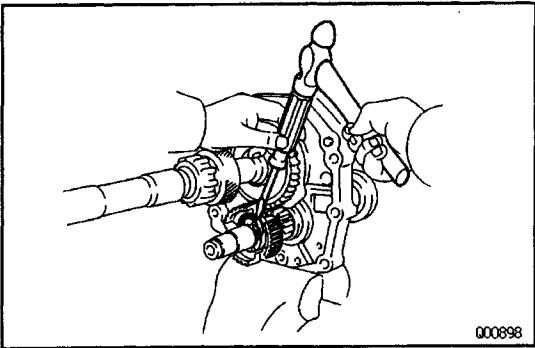

(b) Using a screwdriver and hammer, tap in the snap ring.

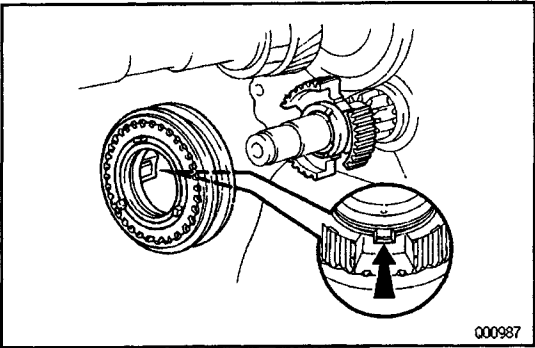

**11. INSTALL NO.3 HUB SLEEVE ASSEMBLY**

- (a) Check for reverse synchronizer pull ring position.
- (b) Install the No.3 hub sleeve assembly to the No.3 clutch hub.

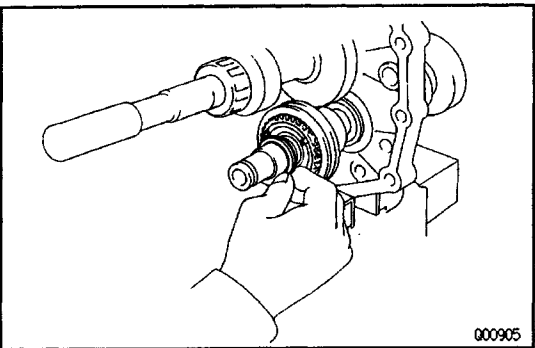

**12. INSTALL SPACER, NEEDLE ROLLER BEARING AND COUNTER FIFTH GEAR**

- (a) Install the spacer.
- (b) Apply gear oil to the needle roller bearing.

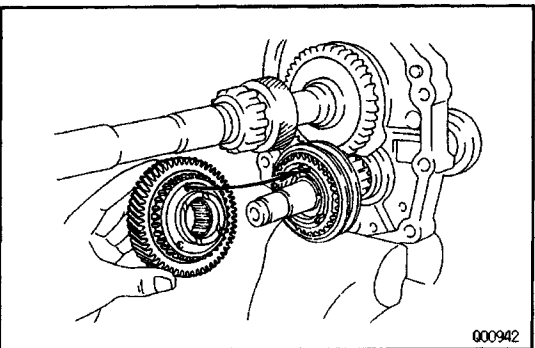

- (c) Install the needle roller bearing to the counter fifth gear.
- (d) Install the counter 5th gear with 5th gear gaps aligned with synchronizer corn ring pin.



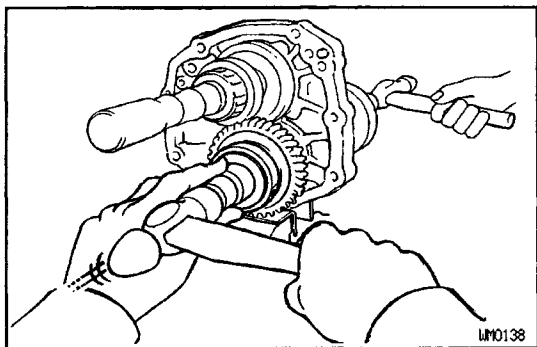

### 13. INSTALL SPACER AND BEARING

- (a) Install the spacer.
- (b) Using a socket wrench and hammer, drive in the bearing.

HINT: When driving in the bearing, support the counter shaft in front with a 3–5 lb hammer or equivalent.

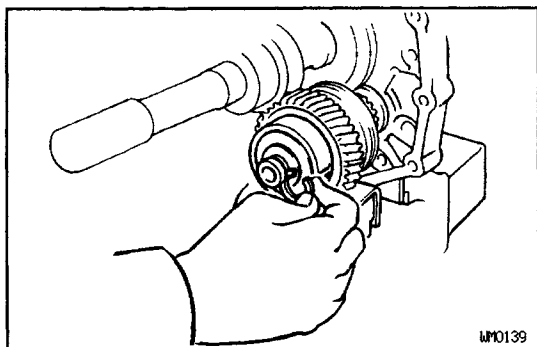

### 14. INSTALL SNAP RING

- (a) Select a snap ring that will allow minimum axial play.

Mark	Thickness mm (in.)
1	1.90–1.95 (0.0748–0.0768)
2	1.96–2.01 (0.0772–0.0791)
3	2.02–2.07 (0.0795–0.0815)
4	2.08–2.13 (0.0819–0.0839)
5	2.14–2.19 (0.0843–0.0862)
6	2.20–2.25 (0.0866–0.0886)
7	2.26–2.31 (0.0890–0.0909)

- (b) Using a snap ring expander, install the snap ring.

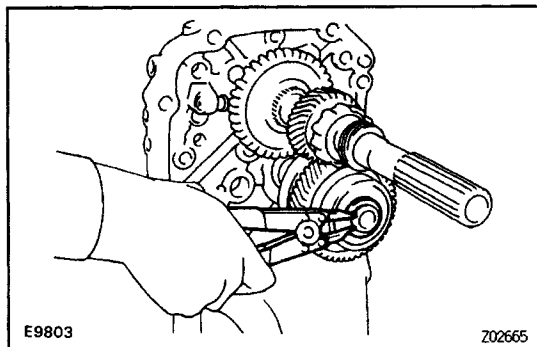

### 15. INSPECT COUNTER FIFTH GEAR THRUST CLEARANCE

Using a feeler gauge, measure the counter 5th gear thrust clearance.

**Standard clearance:**

**0.10–0.41 mm (0.0039–0.0161 in.)**

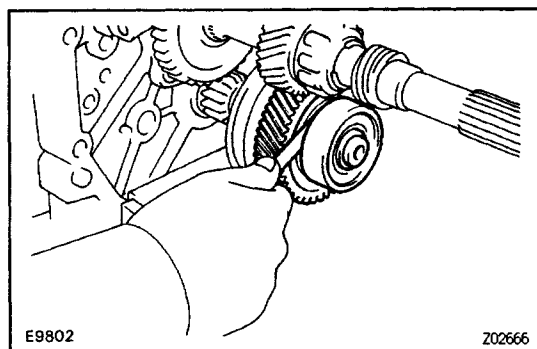

### 16. INSTALL SPEED SENSOR DRIVE GEAR

- (a) Put a clip on the output shaft and install the drive gear clip into the slot.
- (b) Slide the drive gear with clip and fit the clip into the holes.

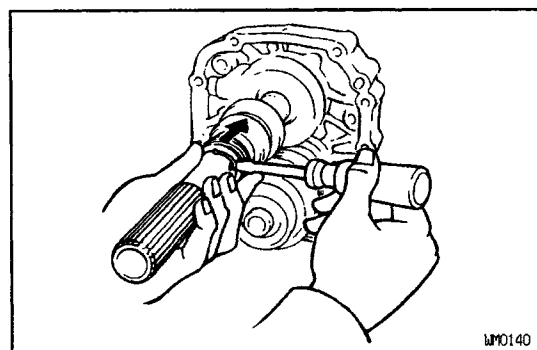

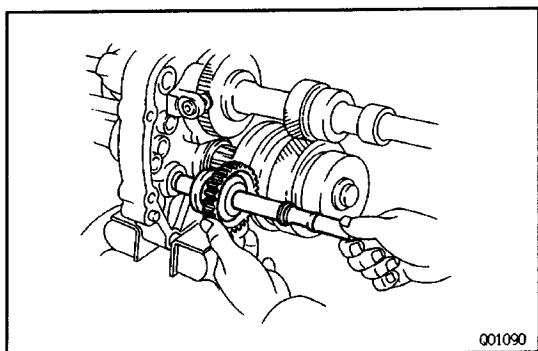

## 17. INSTALL SHIFT FORKS, SHIFT FORK SHAFTS AND REVERSE IDLER GEAR

(a) Install the reverse idler gear and shaft.

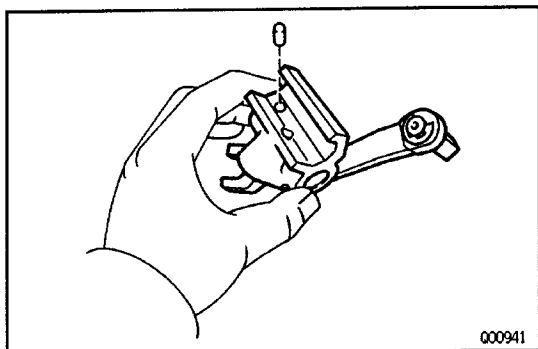

(b) Install the No.3 shift fork, No.3 fork shaft and reverse shift arm.

- Coat the pin with MP grease and insert it into the reverse shift head hole.
- Install the No.3 shaft through the No.3 shift fork and reverse shift arm.
- Align the No.3 shift fork with the No.3 hub sleeve groove, put the reverse shift arm into the pivot of bearing retainer and align the reverse shift arm show with the reverse idler gear groove. Install No.3 the shift fork shaft to the intermediate plate.

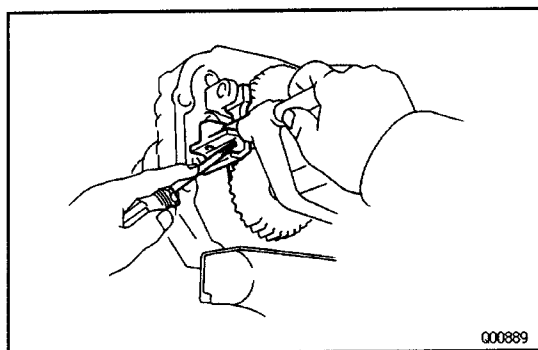
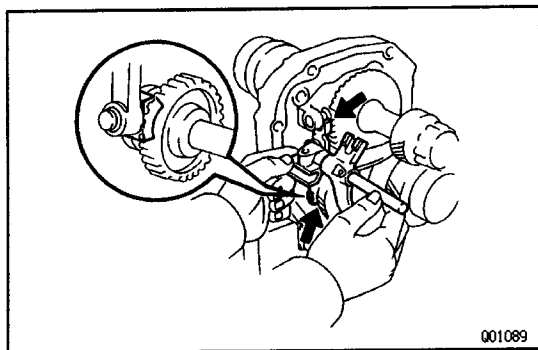

(c) Install the No.4 shift fork shaft.

- Push the pin, which was installed into the reverse shift arm hole, into the groove of No.3 shift fork shaft.
- Install the shift fork shaft No.4 to the intermeddlate plate.

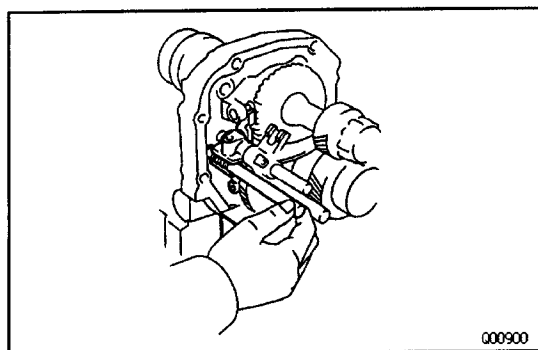

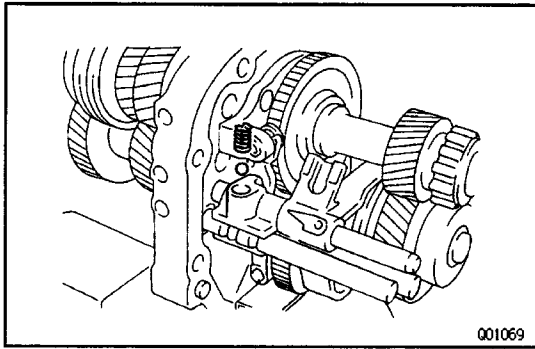

(d) Install the ball and spring.

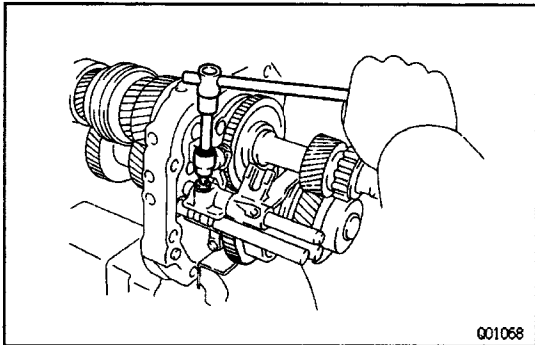

(e) Apply sealant to the plug.

**Sealant:**

**Part No.08833-00080, THREE BOND 1344, LOC-TITE 242 or equivalent**

(f) Using a hexagon wrench, install and torque the plug.

**Torque: 25 N-m (250 kgf-cm, 18 ft-lbf)**

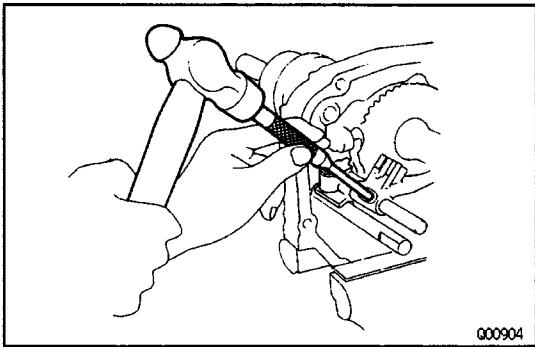

(g) Using a pin punch and hammer, drive in the slotted spring pin until it is flush with the No.3 shift fork.

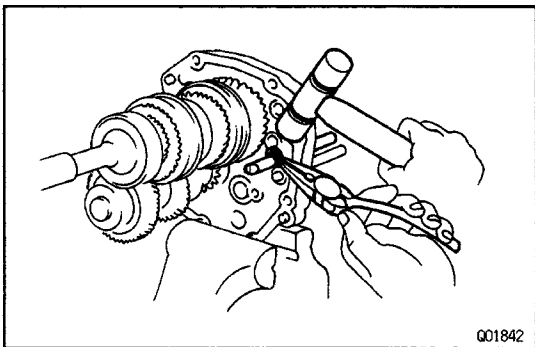

(h) Install the snap ring to the No.3 fork shaft.

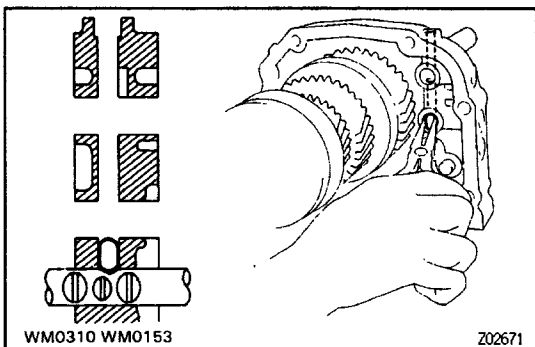

(i) Apply MP grease to the No.3 interlock pin and install the pin into the intermediate plate hole.

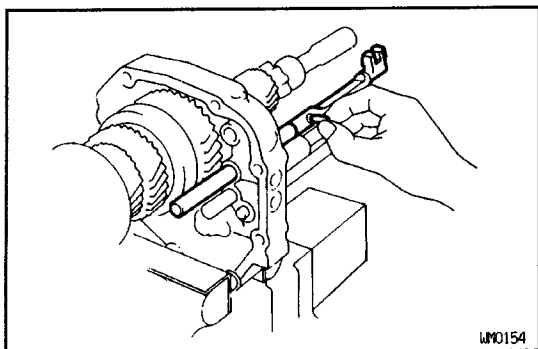

- (j) Install the No.2 shift fork and fork shaft.
- Apply MP grease to No.2 interlock pin and install the pin into the shaft hole.

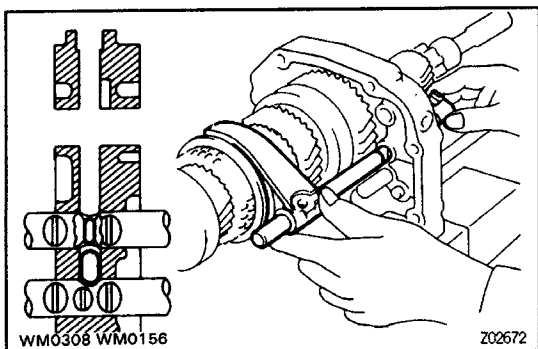

- Place the No.2 shift fork into the groove of No.2 hub sleeve.
- Install the No.2 fork shaft to the shift fork through the intermediate plate.

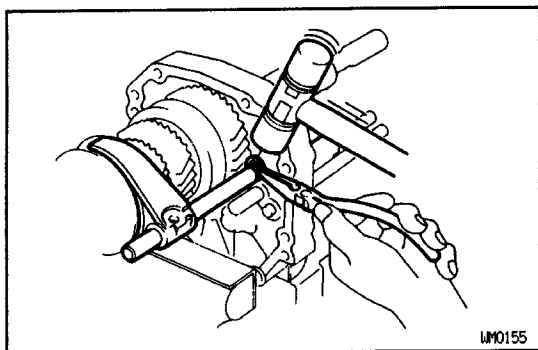

- (k) Install the snap ring to the No.2 fork shaft.

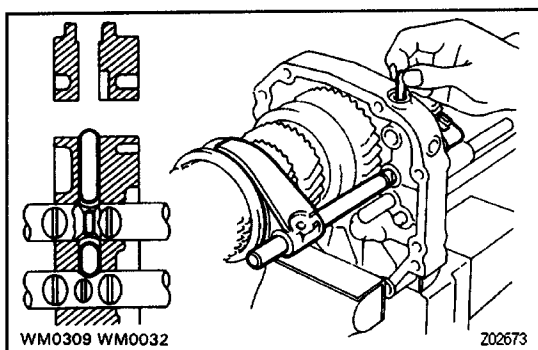

- (l) Apply MP grease to the No.2 interlock pin and install the pin into the intermediate plate.

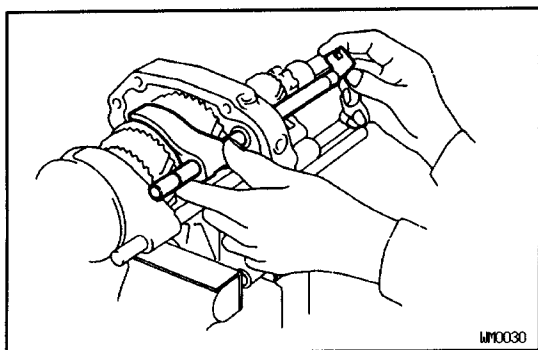

- (m) Install the No.1 shift fork and fork shaft.
- Install the No.1 shift fork into the groove of No.1 hub sleeve.
  - Install the No.1 fork shaft to the shift fork through the intermediate plate.

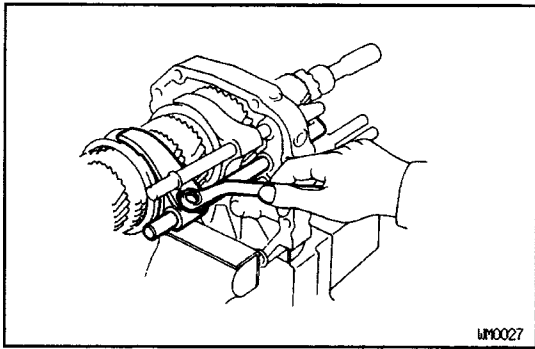

- (n) Install and torque the No.1 and No.2 shift fork set bolts.

**Torque: 20 N-m (200 kgf.cm, 14 ft-lbf)**

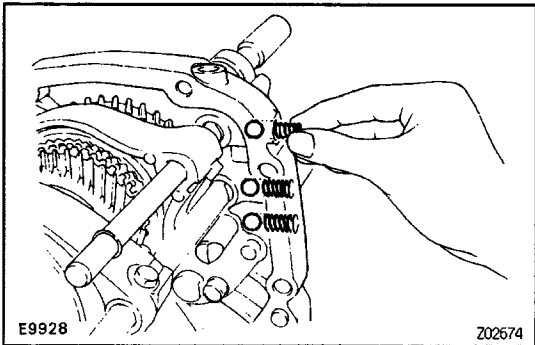

## 18. INSTALL LOCKING BALL AND SPRING

- (a) Install the balls and spring into each hole.

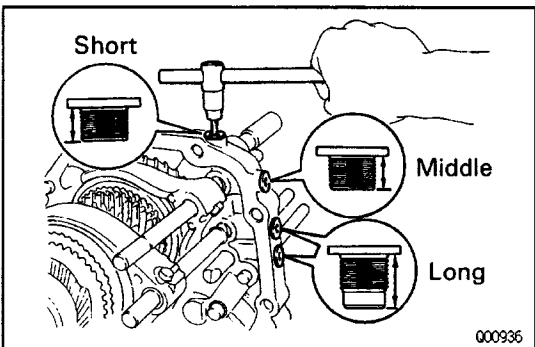

- (b) Apply liquid sealer to the plug threads.

**Sealant:**

**Part No.08833-00080, THREE BOND 1344, LOC-TITE 242 or equivalent**

- (c) Using a hexagon wrench, install the torque the four plugs.

**Torque: 25 N-m (250 kgf-cm, 18 ft-lbf)**

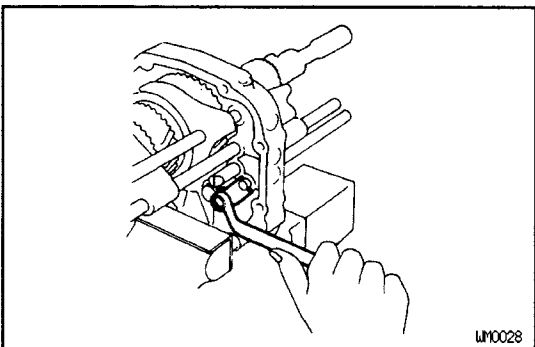

## 19. INSTALL REVERSE IDLER GEAR SHAFT STOPPER

Install the reverse idler gear shaft stopper and torque the bolt.

**Torque: 25 N-m (250 kgf-cm, 18 ft-lbf)**

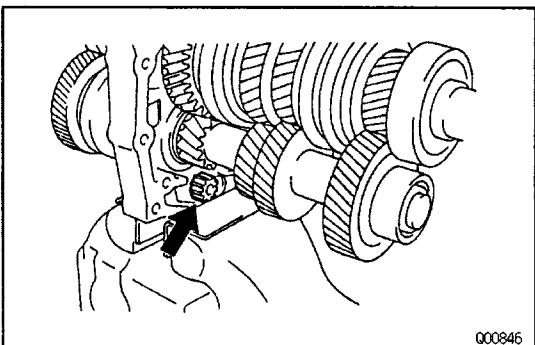

## 20. INSTALL FRONT MAGNET

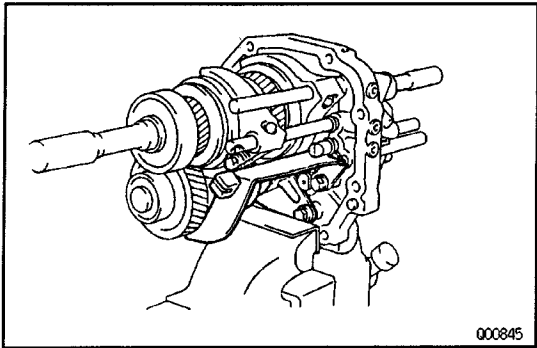

**21. INSTALL OIL SEPARATOR**

Install the oil receiver and torque the two bolts.

**Torque: 18 N-m (185 kgf-cm, 13 ft-lbf)**

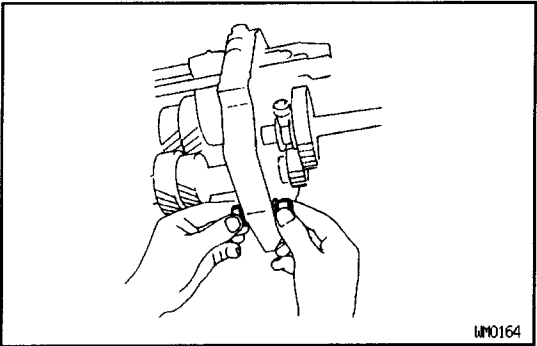

**22. DISMOUNT INTERMEDIATE PLATE FROM VISE**

- (a) Dismount the intermediate plate from the vise.
- (b) Remove the bolts, nuts, plate washers and gasket.

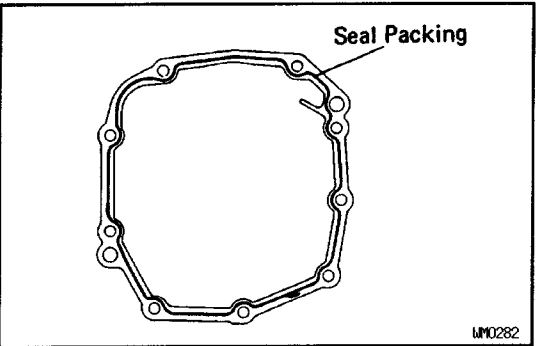

**23. INSTALL TRANSMISSION CASE TO INTERMEDIATE PLATE**

- (a) Remove the any packing material and be careful not to drop oil on the contacting surface of the transmission case or intermediate plate.
- (b) Apply seal packing to the transmission case as shown.

**Seal packing:**

**Part No. 08826 – 00090, THREE BOND 1281 or equivalent**

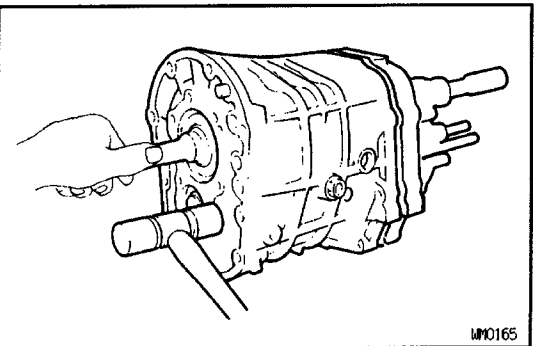

- (c) Align the each bearing outer race and each shift fork shaft end with the case holes.
- (d) Using a plastic hammer, tap on the case to install it.

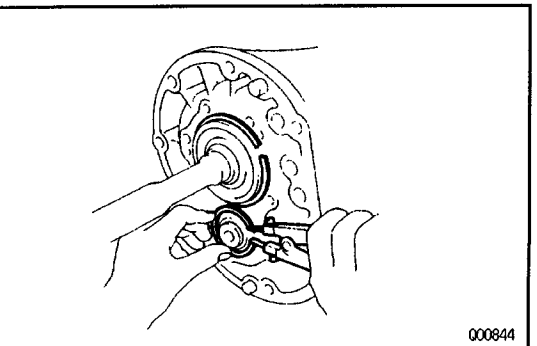

**24. INSTALL BEARING SNAP RINGS**

Using a snap ring expander, install the two snap rings.

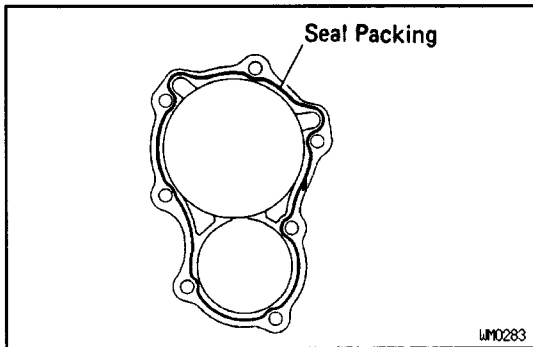

## 25. INSTALL FRONT BEARING RETAINER

- (a) Remove the any packing material and be careful not to drop oil on the contacting surface of the front bearing retainer or transmission case.
- (b) Apply seal packing to the retainer as shown, and install it to the transmission case.

### Seal packing:

**Part No. 08826 – 00090, THREE BOND 1281 or equivalent**

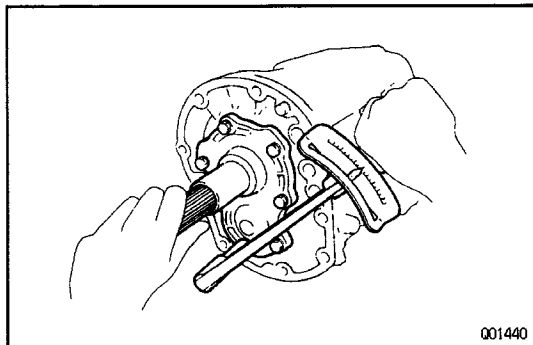

- (c) Apply liquid sealer to the bolt threads.

### Sealant:

**Part No.08833-00080. THREE BOND 1344, LOC-TITE 242 or equivalent**

- (d) Install and torque the bolts.  
**Torque: 25 N-m (250 kgf-cm, 18 ft-lbf)**

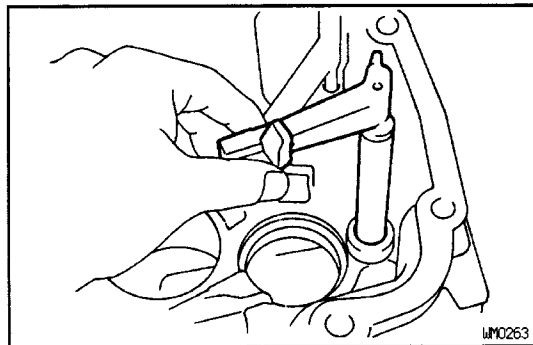

## 26. (2WD)

### INSTALL EXTENSION HOUSING

- (a) Install the shift and select lever into the extension housing.

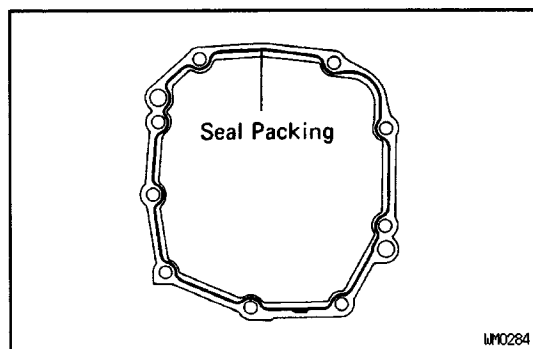

- (b) Remove the any packing material and be careful not to drop oil on the contacting surface of the extension housing or intermediate plate.
- (c) Apply seal packing to the extension housing.

### Seal packing:

**Part No. 08826 – 00090, THREE BOND 1281 or equivalent**

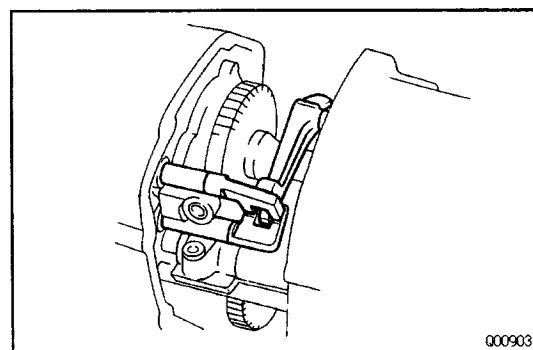

- (d) Connect the shift and select lever to the shift fork shaft.

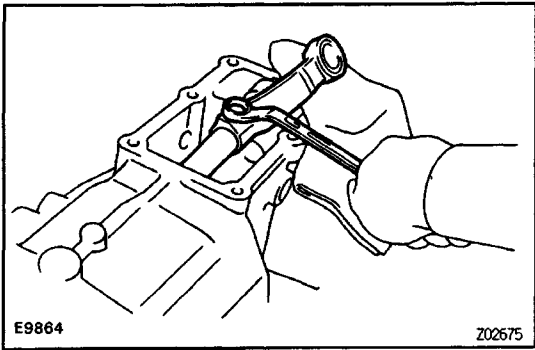

- (e) Install the shift lever housing to the shift and select lever shaft, push in the extension housing.
- (f) Install and torque the bolt.

**Torque: 39 N-m (400 kgf-cm, 29 ft-lbf)**

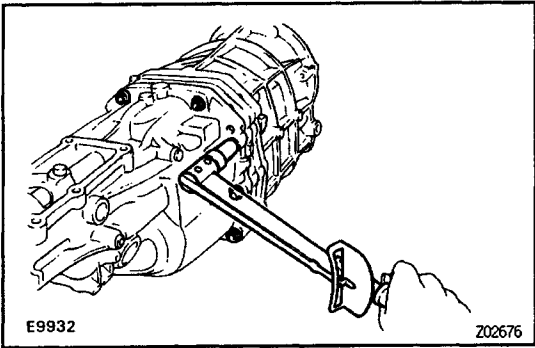

- (g) Install the nine bolts to the extension housing.
- (h) Torque the bolts.

**Torque: 37 N-m (375 kgf-cm, 27 ft-lbf)**

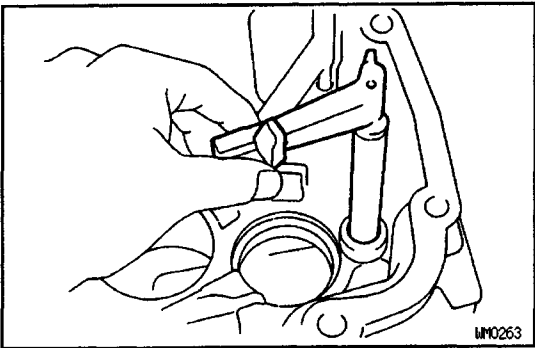

**27. (4WD)**

**INSTALL TRANSFER ADAPTOR**

- (a) Install the shift and select lever into the transfer adaptor.

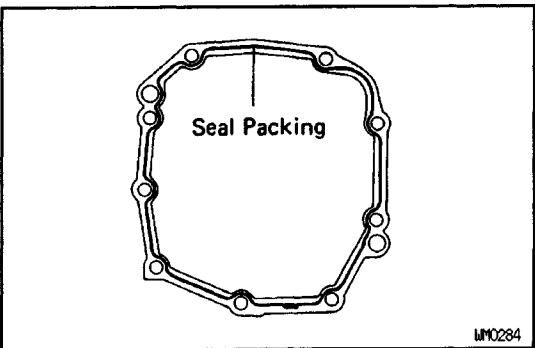

- (b) Remove the any packing material and be careful not to drop oil on the contacting surface of the transfer adaptor or intermediate plate.
- (c) Apply seal packing to the extension housing.

**Seal packing:**

**Part No. 08826 – 00090, THREE BOND 1281 or equivalent**

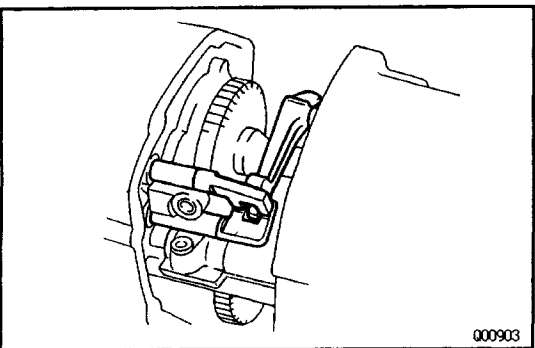

- (d) Connect the shift and select lever to the shift fork shaft.



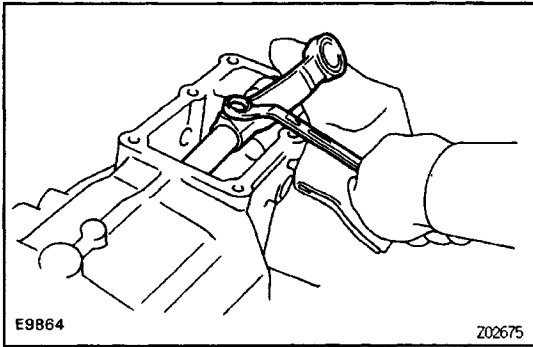

- (e) Install the shift lever housing to the shift and select lever shaft, push in the transfer adaptor.
- (f) Install and torque the bolt.

**Torque: 39 N-m (400 kgf-cm, 29 ft-lbf)**

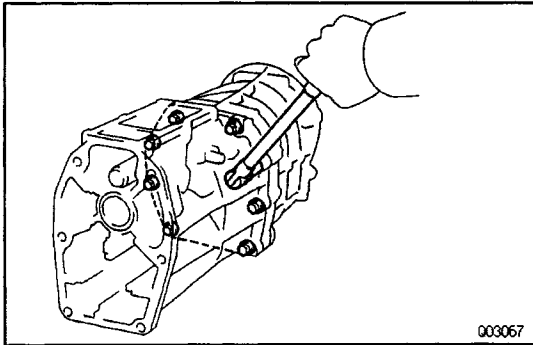

- (g) Install the nine bolts to the transfer adaptor.
- (h) Torque the bolts.

**Torque: 37 N-m (380 kgf-cm, 27ft-lbf)**

## 28. AFTER INSTALLING EXTENSION HOUSING, CHECK FOLLOWING ITEMS:

- (a) Check to see that the input shaft and output shaft rotate smoothly.
- (b) Check to see that shifting can be made smoothly to all positions.

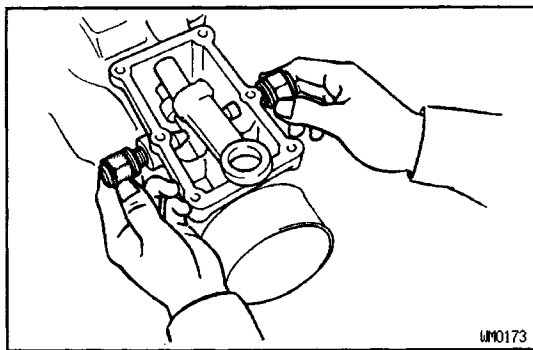

## 29. INSTALL RESTRICT PINS

- (a) Install the restrict pins together with a gasket.
- HINT: Install the black pin on the reverse gear/5th gear side.

- (b) Torque the restrict pins.

**Torque: 40 N-m (410 kgf-cm, 30 ft-lbf)**

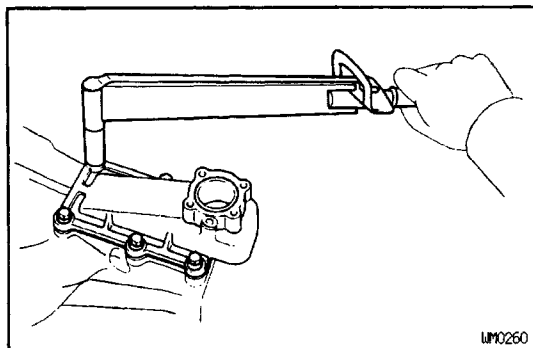

## 30. (2WD)

### INSTALL SHIFT LEVER RETAINER

- (a) Install the shift lever retainer with a oil baffle.
- (b) Install and torque the six bolts.

**Torque: 18 N-m (185 kgf-cm, 13 ft-lbf)**

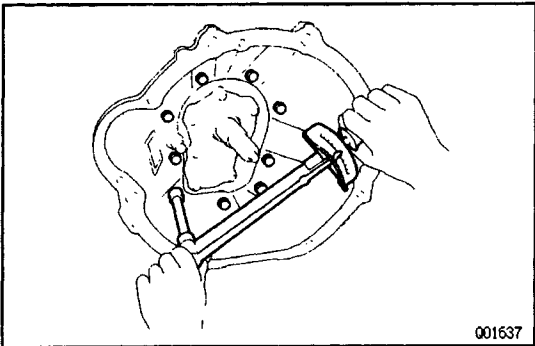
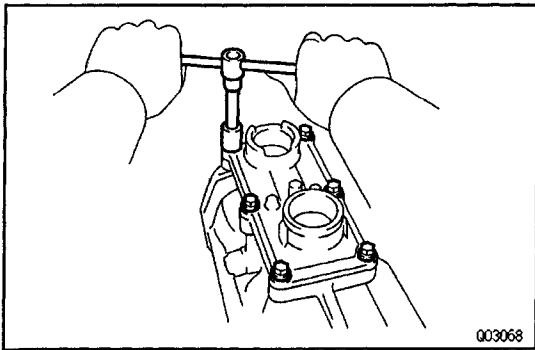

### 31. INSTALL CLUTCH HOUSING

- (a) Install the clutch housing.
- (b) Install and torque the nine bolts.

**Torque: 37 N-m (375 kgf-cm, 27 ft-lbf)**

### 32. INSTALL VEHICLE SPEED SENSOR

- (a) Install the speed sensor.
- (b) Install and torque the set bolt.

**Torque: 13 N-m (130 kgf-cm, 9 ft-lbf)**

### 33. INSTALL BACK-UP LIGHT SWITCH

- (a) Install and torque the back-up light switch.

**Torque: 40 N-m (410 kgf-cm, 30 ft-lbf)**

- (b) Install the wire clamp.

**SERVICE SPECIFICATIONS**

MT010-C2

**SERVICE DATA**

Output shaft 2nd gear journal diameter			
	Limit	<b>42.975 mm</b>	<b>1.6919 in.</b>
Output shaft 3rd gear journal diameter			
	Limit	<b>31.969 mm</b>	<b>1.2586 in.</b>
Output shaft flange thickness			
	Limit	<b>5.60 mm</b>	<b>0.2205 in.</b>
Output shaft runout			
	Limit	<b>0.06 mm</b>	<b>0.0024 in.</b>
1 st gear inner race flange thickness			
	Limit	<b>4.87 mm</b>	<b>0.1882 in.</b>
1 st gear inner race outer diameter			
	Limit	<b>42.975 mm</b>	<b>1.6919 in.</b>
Counter gear bearing journal diameter			
	Limit	<b>29.950 mm</b>	<b>1.1791 in.</b>
Counter 5th gear journal diameter			
	Limit	<b>26.975 mm</b>	<b>1.6919 in.</b>
1st, 2nd and 3rd Gear thrust clearance			
	STD	<b>0.10 – 0.25 mm</b>	<b>0.0039 – 0.0098 in.</b>
	Limit	<b>0.30 mm</b>	<b>0.0118 in.</b>
Counter 5th gear thrust clearance			
	STD	<b>0.10 – 0.41 mm</b>	<b>0.0039 – 0.0161 in.</b>
	Limit	<b>0.46 mm</b>	<b>0.0181 in.</b>
1 st, 2nd and counter 5th gear oil clearance			
	STD	<b>0.009 – 0.060 mm</b>	<b>0.0004 – 0.0024 in.</b>
	Limit	<b>0.15 mm</b>	<b>0.0059 in.</b>
3rd gear oil clearance			
	STD	<b>0.015 – 0.066 mm</b>	<b>0.0006 – 0.0026 in.</b>
	Limit	<b>0.20 mm</b>	<b>0.0079 in.</b>
Reverse idler gear to shift arm shoe			
	STD	<b>0.041 – 0.074 mm</b>	<b>0.0016 – 0.0029 in.</b>
	Limit	<b>0.194 mm</b>	<b>0.0076 in.</b>
Shift fork to hub sleeve clearance			
	Limit	<b>1.0 mm</b>	<b>0.039 in.</b>
Synchronizer ring to 1 st and 4th gear clearance			
	Limit	<b>0.5 mm</b>	<b>0.020 in.</b>
Synchronizer ring to 2nd and 3rd gear clearance			
	Limit	<b>0.7 mm</b>	<b>0.028 in.</b>
Input shaft snap ring thickness			
	<b>Mark 1</b>	<b>2.05 – 2.10 mm</b>	<b>0.0807 – 0.0827 in.</b>
	<b>Mark 2</b>	<b>2.10 – 2.15 mm</b>	<b>0.0827 – 0.0846 in.</b>
	<b>Mark 3</b>	<b>2.15 – 2.20 mm</b>	<b>0.0846 – 0.0866 in.</b>
	<b>Mark 4</b>	<b>2.20 – 2.25 mm</b>	<b>0.0866 – 0.0886 in.</b>
	<b>Mark 5</b>	<b>2.25 – 2.30 mm</b>	<b>0.0886 – 0.0906 in.</b>
	<b>Mark 11</b>	<b>2.30 – 2.35 mm</b>	<b>0.0906 – 0.0925 in.</b>
	<b>Mark 12</b>	<b>2.35 – 2.40 mm</b>	<b>0.0925 – 0.0945 in.</b>

Output shaft snap ring thickness			
No.2 clutch hub	Mark C-1	1.75 – 1.80 mm	0.0689 – 0.0709 in.
No.2 clutch hub	Mark 11	1.86 – 1.91 mm	0.0732 – 0.0752 in.
No.2 clutch hub	Mark 12	1.92 – 1.97 mm	0.0756 – 0.0776 in.
No.2 clutch hub	Mark 13	1.98 – 2.03 mm	0.0780 – 0.0799 in.
No.2 clutch hub	Mark 14	2.04 – 2.09 mm	0.0803 – 0.0823 in.
No.2 clutch hub	Mark 15	2.10 – 2.15 mm	0.0827 – 0.0846 in.
Rear bearing	Mark 8	2.31 – 2.36 mm	0.0909 – 0.0929 in.
Rear bearing	Mark 9	2.37 – 2.42 mm	0.0933 – 0.0953 in.
Rear bearing	Mark 10	2.43 – 2.48 mm	0.0957 – 0.0976 in.
Rear bearing	Mark 11	2.49 – 2.54 mm	0.0980 – 0.1000 in.
Rear bearing	Mark 12	2.55 – 2.60 mm	0.1004 – 0.1024 in.
Rear bearing	Mark 13	2.61 – 2.66 mm	0.1028 – 0.1047 in.
Rear bearing	Mark 14	2.68 – 2.73 mm	0.1055 – 0.1075 in.
Rear bearing	Mark 15	2.74 – 2.79 mm	0.1079 – 0.1098 in.
Reverse gear	Mark 5	2.25 – 2.30 mm	0.0886 – 0.0906 in.
Reverse gear	Mark 11	2.30 – 2.35 mm	0.0906 – 0.0925 in.
Reverse gear	Mark 12	2.35 – 2.40 mm	0.0925 – 0.0945 in.
Reverse gear	Mark 13	2.40 – 2.45 mm	0.0945 – 0.0965 in.
Reverse gear	Mark 14	2.45 – 2.50 mm	0.0965 – 0.0984 in.
Reverse gear	Mark 15	2.50 – 2.55 mm	0.0984 – 0.1004 in.
Reverse gear	Mark 16	2.55 – 2.60 mm	0.1004 – 0.1024 in.
Reverse gear	Mark 17	2.61 – 2.66 mm	0.1028 – 0.1047 in.
Reverse gear	Mark 18	2.67 – 2.72 mm	0.1051 – 0.1071 in.
Reverse gear	Mark 19	2.73 – 2.78 mm	0.1075 – 0.1094 in.
Reverse gear	Mark 20	2.79 – 2.84 mm	0.1098 – 0.1118 in.
Reverse gear	Mark 21	2.85 – 2.90 mm	0.1122 – 0.1142 in.
Reverse gear	Mark 22	2.91 – 2.96 mm	0.1146 – 0.1165 in.
Reverse gear	Mark 23	2.97 – 3.02 mm	0.1169 – 0.1189 in.
Counter gear snap ring thickness			
Front bearing	Mark A	2.05 – 2.10 mm	0.0807 – 0.0827 in.
Front bearing	Mark B	2.10 – 2.15 mm	0.0827 – 0.0846 in.
Front bearing	Mark C	2.15 – 2.20 mm	0.0846 – 0.0866 in.
Front bearing	Mark D	2.20 – 2.25 mm	0.0866 – 0.0886 in.
Front bearing	Mark E	2.25 – 2.30 mm	0.0886 – 0.0906 in.
Front bearing	Mark F	2.30 – 2.35 mm	0.0906 – 0.0925 in.
Front bearing	Mark G	2.35 – 2.40 mm	0.0925 – 0.0945 in.
No.3 clutch hub	Mark 2	2.06 – 2.11 mm	0.0811 – 0.0831 in.
No.3 clutch hub	Mark 3	2.12 – 2.17 mm	0.0835 – 0.0854 in.
No.3 clutch hub	Mark 4	2.18 – 2.23 mm	0.0858 – 0.0878 in.
No.3 clutch hub	Mark 5	2.24 – 2.29 mm	0.0882 – 0.0902 in.
Rear bearing	Mark 1	1.90 – 1.95 mm	0.0748 – 0.0768 in.
Rear bearing	Mark 2	1.96 – 2.01 mm	0.0772 – 0.0791 in.
Rear bearing	Mark 3	2.02 – 2.07 mm	0.0795 – 0.0815 in.
Rear bearing	Mark 4	2.08 – 2.13 mm	0.0819 – 0.0839 in.
Rear bearing	Mark 5	2.14 – 2.19 mm	0.0843 – 0.0862 in.
Rear bearing	Mark 6	2.20 – 2.25 mm	0.0866 – 0.0886 in.
Rear bearing	Mark 7	2.26 – 2.31 mm	0.0890 – 0.0909 in.

Oil seal drive in depth	
Front bearing retainer (from retainer end)	11.4 – 12.0 mm      0.449 – 0.472 in.

## TORQUE SPECIFICATIONS

MT011-02

Part tightened	N·m	kgf·cm	ft·lbf
Transfer x Transfer adaptor	39	400	29
Engine rear mounting x Transmission	25	260	19
Transmission x Engine	72	730	53
Transmission x Stiffener plate	37	380	27
Transmission x Starter	39	400	29
Clutch tube bracket x Transmission	72	730	53
Frame auxiliary crossmember	95	970	70
Engine rear mounting bracket x Support member	58	590	43
Engine rear mounting bracket x Engine rear mounting	29	300	22
No.2 crossmember x Frame	95	970	70
No.2 crossmember x Engine rear mounting	13	130	9
Stabilizer bracket	29	300	22
Exhaust pipe x Exhaust manifold	62	630	46
Exhaust- pipe x bracket x Clutch housing			
Upper	19	195	14
Lower	69	700	51
Exhaust pipe clamp	19	195	14
Clutch release cylinder x Transmission	12	120	9
Front propeller shaft x Front differential	74	750	54
Front propeller shaft x Transfer	74	750	54
Rear propeller shaft x Transfer	74	750	54
Rear propeller shaft center bearing x Frame	37	370	27
Shift fork set bolt	20	200	14
Straight screw plug	25	250	18
Reverse idler gear shaft stopper bolt	25	250	18
Oil separator x Intermediate plate	18	185	13
Front bearing retainer set bolt	25	250	18
Extension housing x Intermediate plate or Transfer adaptor	37	375	27
Restrict pin	40	410	30
Shift lever housing x Shift and select lever shaft	39	400	29
Shift lever retainer x Extension housing or Transfer adaptor	18	185	13
Drain and filler plugs	40	410	30
Back-up light switch	40	410	30
Clutch housing x Transmission case	37	375	27
Rear bearing retainer x Intermediate plate	13	130	9

# AUTOMATIC TRANSMISSION

MEMO

# **A43D Automatic Transmission**



## DESCRIPTION

### General

The A43D is a 4–speed automatic transmission.

The A43D transmission is mainly composed of the torque converter clutch, the overdrive (hereafter called O/D) planetary gear unit, 3–speed planetary gear unit, the hydraulic control system and the electronic control system.

**Sectional View**

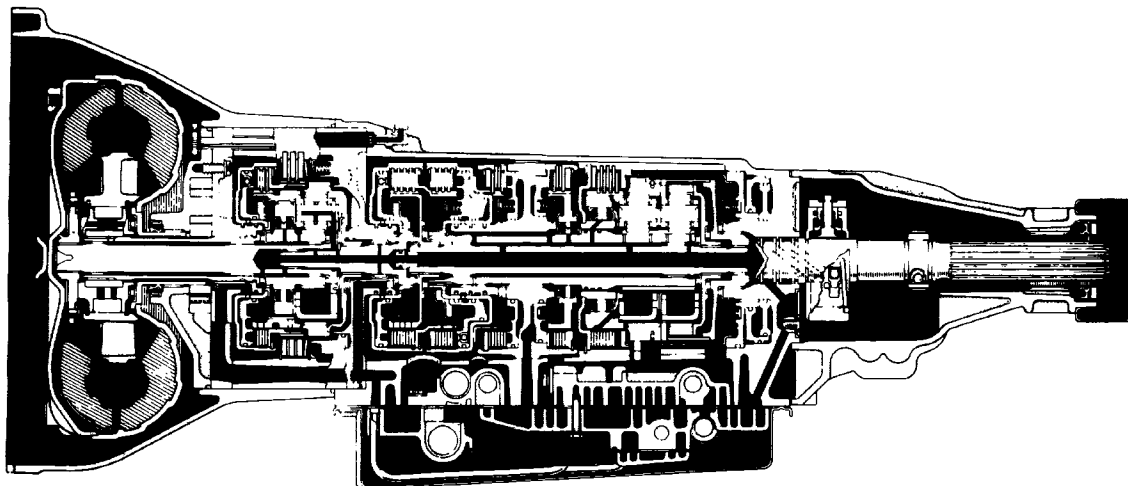

AT4220

# General Specifications

Type of Transmission		<b>A43D</b>	
Type of Engine		<b>22R-E</b>	
Torque Converter Clutch	Stall Torque Ratio		<b>1.75 : 1</b>
	Lock-Up Mechanism		<b>Equipped</b>
Gear Ratio	1 st Gear		<b>2.452</b>
	2nd Gear		<b>1.452</b>
	3rd Gear		<b>1.000</b>
	O/D Gear		<b>0.688</b>
	Reverse Gear		<b>2.212</b>
Plates (Disc/Plate)	<b>C<sub>0</sub></b>	O/D Direct Clutch	<b>1/0</b>
	<b>C<sub>1</sub></b>	Front Clutch	<b>4/4</b>
	<b>C<sub>2</sub></b>	Rear Clutch	<b>3/3</b>
	<b>B<sub>2</sub></b>	No.2 Brake	<b>3/3</b>
	<b>B<sub>3</sub></b>	No.3 Brake	<b>5/4</b>
	<b>B<sub>0</sub></b>	O/D Brake	<b>3/3</b>
	<b>B<sub>1</sub></b>	No. 1 Brake	<b>1/1</b>
ATF	Type		<b>ATF DEXRON® II</b>
	Capacity liter (US qts, Imp.qts)	Total	<b>6.5 (6.9, 5.7)</b>
		Drain and Ref ill	<b>2.4 (2.5, 2.1)</b>

# OPERATION

## Mechanical Operation

### OPERATING CONDITIONS

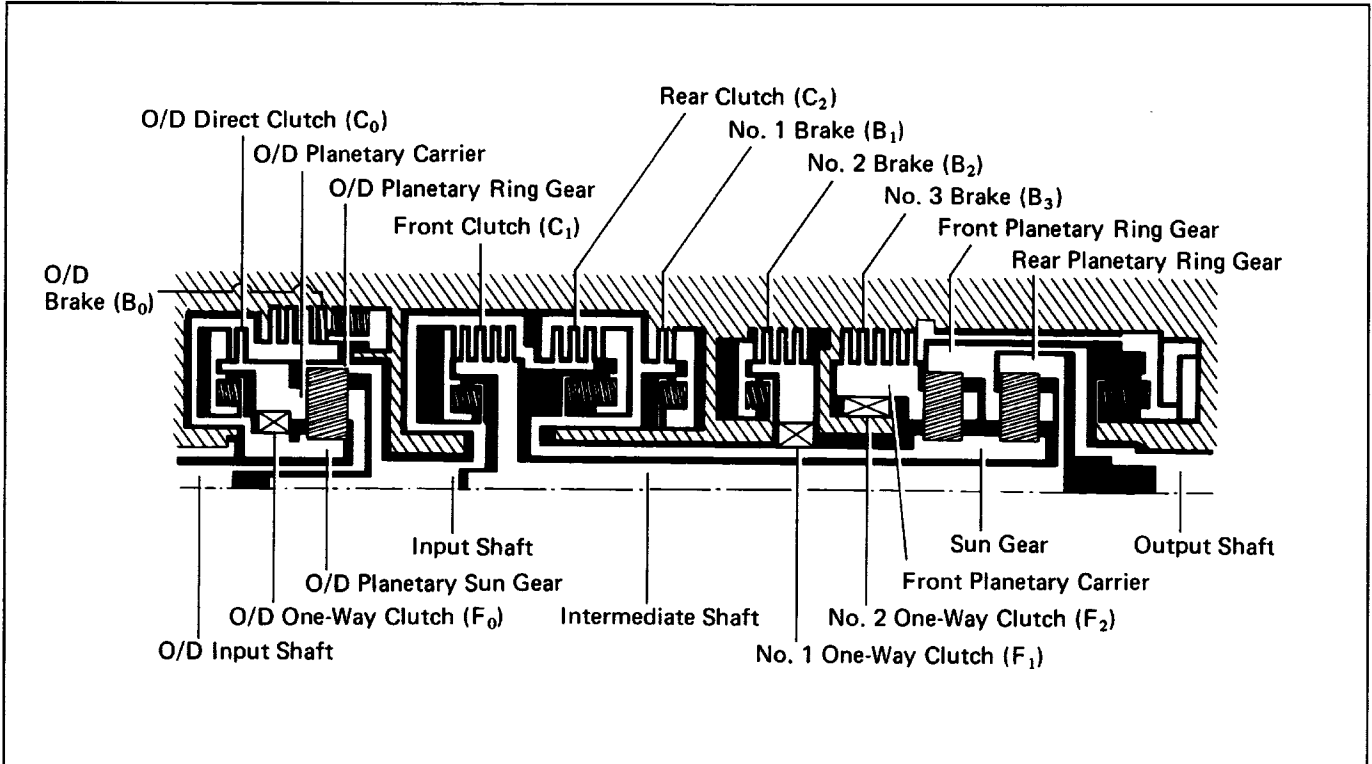

AT3283

○ ..... Operating

Shift lever position	Gear position	C <sub>0</sub>	C <sub>1</sub>	C <sub>2</sub>		B <sub>0</sub>	B <sub>1</sub>	B <sub>2</sub>	B <sub>3</sub>		F <sub>0</sub>	F <sub>1</sub>	F <sub>2</sub>
				I.P.	O.P.				I.P.	O.P.			
P	Parking	○							○	○	○		
R	Reverse	○		○	○				○	○	○		
N	Neutral	○									○		
D	1 st	○	○								○		○
	2nd	○	○					○			○	○	
	3rd	○	○		○			○			○		
	O/D		○		○	○		○					
2	1st	○	○								○		○
	2nd	○	○				○	○			○	○	
L	1 st	○	○						○	○	○		○

I.P. .... Inner Piston  
O.P. .... Outer Piston

# FUNCTION OF COMPONENTS

NOMENCLATURE	OPERATION
O/D Direct Clutch (C <sub>O</sub> )	Connects overdrive sun gear and overdrive carrier
O/D Brake (B <sub>0</sub> )	Prevents overdrive sun gear from turning either clockwise or counterclockwise
O/D One-Way Clutch (F <sub>0</sub> )	When transmission is being driven by engine, connects overdrive sun gear and overdrive carrier
Front Clutch (C <sub>1</sub> )	Connects input shaft and intermediate shaft
Rear Clutch (C <sub>2</sub> )	Connects input shaft and front & rear planetary sun gear
No. 1 Brake (B <sub>1</sub> )	Prevents front & rear planetary sun gear from turning either clockwise or counterclockwise
No.2 Brake (B <sub>2</sub> )	Prevents outer race of F <sub>1</sub> from turning either clockwise or counterclockwise, thus preventing front & rear planetary sun gear from turning counterclockwise
No.3 Brake (B <sub>3</sub> )	Prevents front planetary carrier from turning either clockwise or counterclockwise
No. 1 One-Way Clutch (F <sub>1</sub> )	When B <sub>2</sub> is operating, prevents front & rear planetary sun gear from turning counterclockwise
No.2 One-Way Clutch (F <sub>2</sub> )	Prevents front planetary carrier from turning counterclockwise

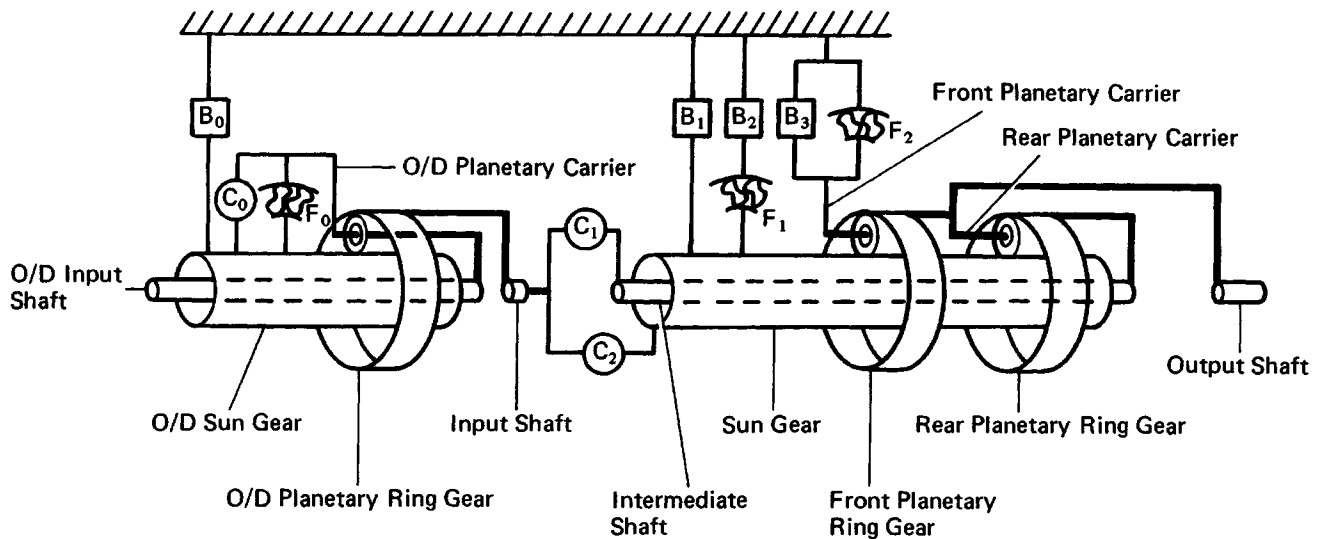

## FUNCTION OF COMPONENTS (Cont'd)

The conditions of operation for each gear position are shown in the following illustrations:

**D or 2 Position 1st Gear**

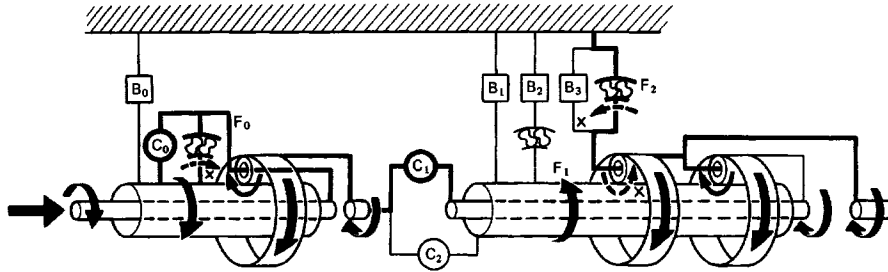

AT7802

**D Position 2nd Gear**

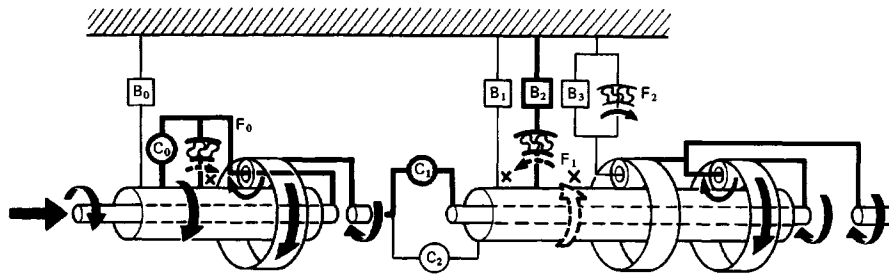

AT7803

**D or 2 Position 3rd Gear**

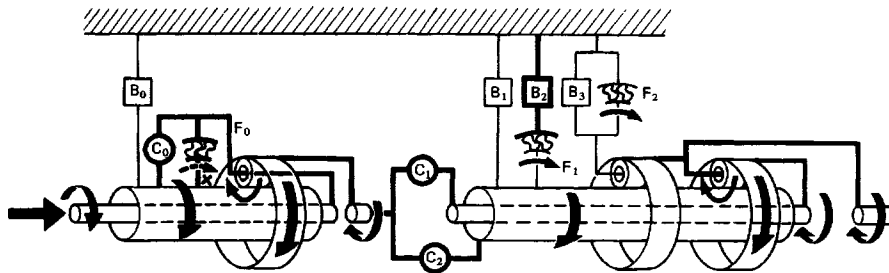

AT7804

**D Position O/D**

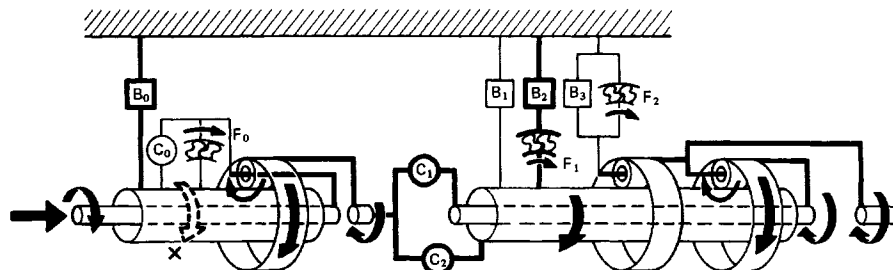

AT7805

# FUNCTION OF COMPONENTS (Cont'd)

**2 or L Position 2nd Gear**

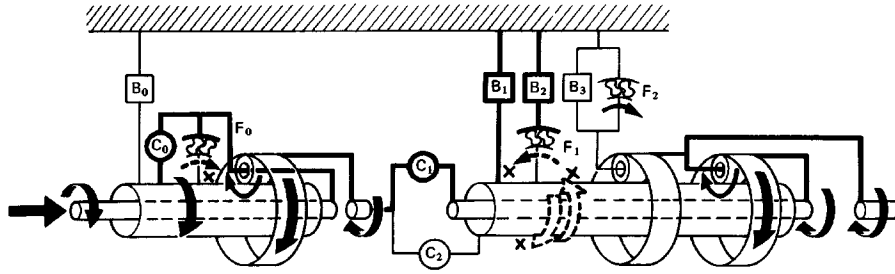

AT7806

**L Position 1st Gear**

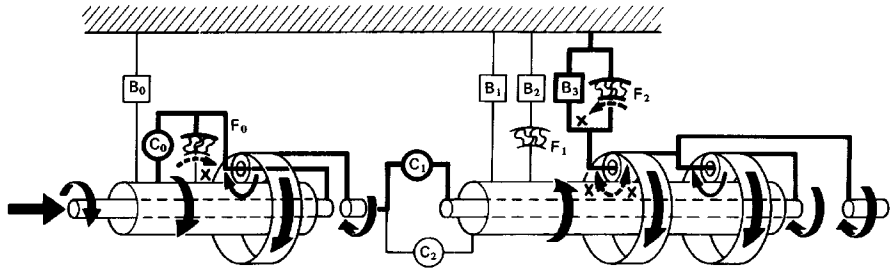

AT7807

**R Position Reverse Gear**

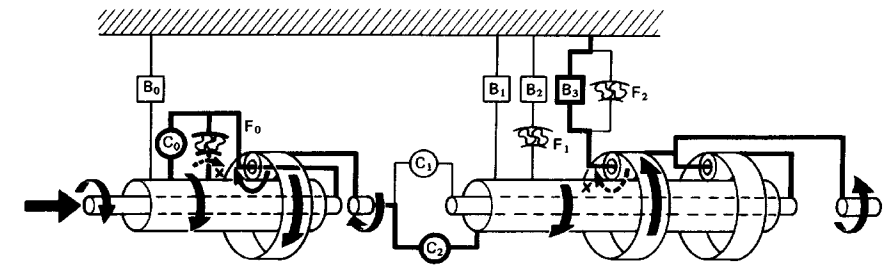

AT7808

## Hydraulic Control System

The hydraulic control system is composed of the oil pump, the valve body, the governor body, the accumulators, the clutches and brakes as well as the fluid passages which connect all of these components. Based in the hydraulic pressure created by the oil pump, the hydraulic control system governs the hydraulic pressure acting on the torque converter clutch, clutches and brakes in accordance with the vehicle driving conditions.

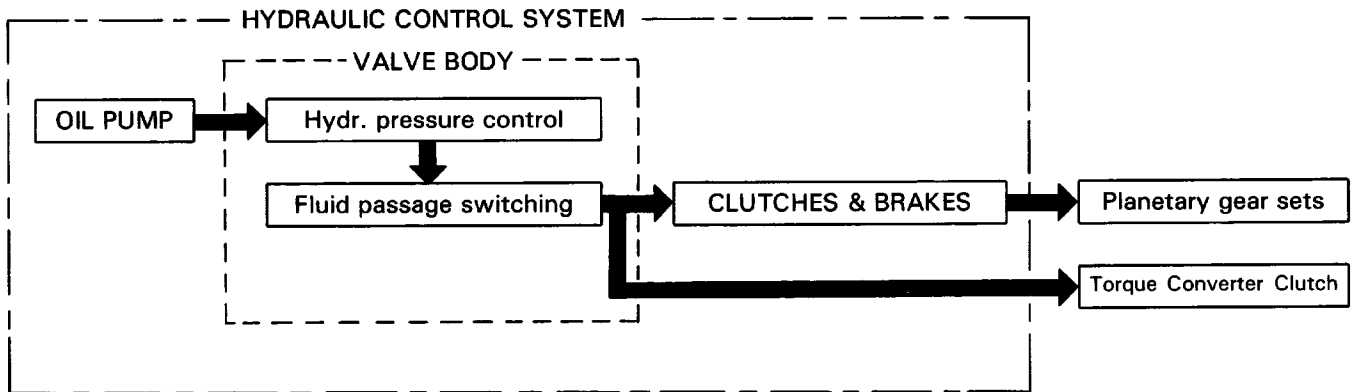

# TROUBLESHOOTING

## Basic Troubleshooting

1. Troubleshooting occurring with the automatic transmission can be caused by either the engine, electrical control or the transmission itself. These three areas should be distinctly isolated before proceeding with troubleshooting.
2. Troubleshooting should begin with the simplest operation, working up in order of difficulty, but first determine whether the trouble lies within the engine, electrical control or transmission.
3. Proceed with the inspection as follows:

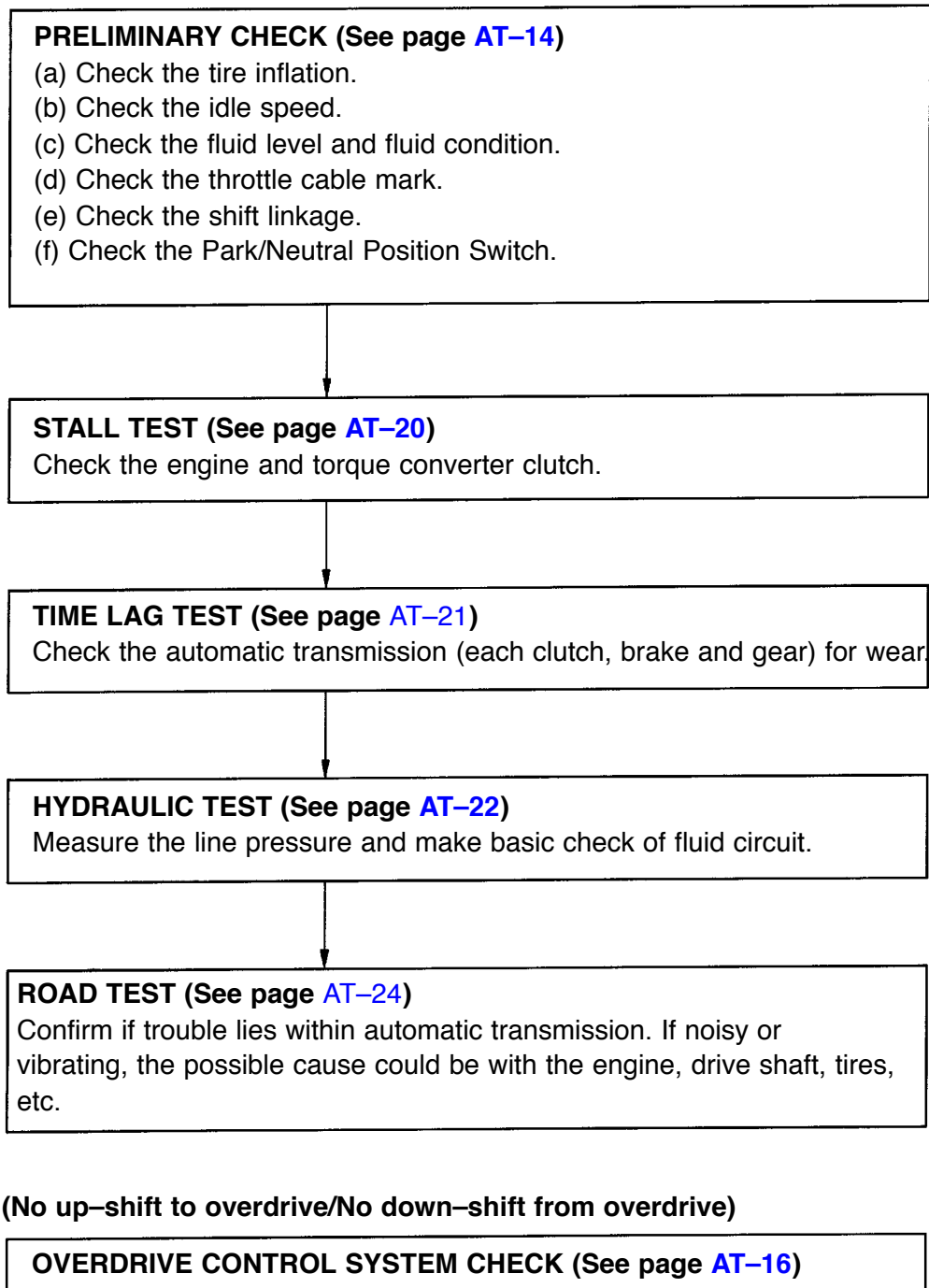



## General Troubleshooting

Problem	Possible cause	Remedy	Page
Fluid discolored or smells burnt	Fluid contaminated Torque converter clutch faulty Transmission faulty	Replace fluid Replace torque converter clutch Disassemble and inspect transmission	AT-14 AT-40
Vehicle does not move in any forward position or reverse	Manual linkage out of adjustment Valve body or primary regulator faulty Parking lock pawl faulty Torque converter clutch faulty Converter drive plate broken Oil pump intake screen blocked Transmission faulty	Adjust linkage Inspect valve body Inspect parking lock pawl Replace torque converter clutch Replace drive plate Clean screen Disassemble and inspect transmission	AT-15 AT-31 AT-40 AT-40
Shift lever position incorrect	Manual linkage out of adjustment Manual valve and lever faulty Transmission faulty	Adjust linkage Inspect valve body Disassemble and inspect transmission	AT-15
Harsh engagement into any drive position	Throttle cable out of adjustment Valve body or primary regulator faulty Accumulator pistons faulty Transmission faulty	Adjust throttle cable Inspect valve body Inspect accumulator pistons Disassemble and inspect transmission	AT-15
Delayed 1-2, 2-3 or 3-0/D up-shift, or down-shift from O/D-3 or 3-2 then shifts back to O/D or 3	Throttle cable out of adjustment Valve body faulty Governor body faulty	Adjust throttle cable Inspect valve body Inspect governor body	AT-15
Slips on 1-2, 2-3 or 3-0/D up-shift, or slips or shudders on acceleration	Manual linkage out of adjustment Throttle cable out of adjustment Valve body faulty Transmission faulty	Adjust linkage Adjust throttle cable Inspect valve body Disassemble and inspect transmission	AT-15 AT-15

Remark \*: Refer to A43D Automatic Transmission Repair Manual.  
(Pub. No. RM 272U )

## General Troubleshooting (Cont'd)

Problem	Possible cause	Remedy	Page
Drag, binding or tie-up on 1-2, 2-3 or 3-O/D up-shift	Manual linkage out of adjustment Valve body faulty Transmission faulty	Adjust linkage Inspect valve body Disassemble and inspect transmission	AT-15
Harsh down-shift	Throttle cable out of adjustment Throttle cable and cam faulty Accumulator pistons faulty Valve body faulty Transmission faulty	Adjust throttle cable Inspect throttle cable and cam Inspect accumulator pistons Inspect valve body Disassemble and inspect transmission	AT-15 AT-15
No down-shift when coasting	Valve body faulty Governor body faulty	Inspect valve body Inspect governor body	★
Down-shift occurs too quickly or too late while coasting	Throttle cable faulty Valve body faulty Governor body faulty Transmission faulty	Inspect throttle cable Inspect valve body Inspect governor body Disassemble and inspect transmission	AT-15
No O/D-3, 3-2 or 2-1 kick-down	Throttle cable out of adjustment Governor body faulty Valve body faulty	Adjust throttle cable Inspect governor body Inspect valve body	AT-15
No engine braking in 2 or L position	Valve body faulty Transmission faulty	Inspect valve body Disassemble and inspect transmission	★
Vehicle does not hold in P	Manual linkage out of adjustment Parking lock pawl cam and spring faulty	Adjust linkage Inspect cam and spring	AT-15 AT-15

Remark \* : Refer to A43D Automatic Transmission Repair Manual.  
(Pub. No. RM272U)

## Preliminary Check

### 1. CHECK FLUID LEVEL

#### HINT:

- The vehicle must have been driven so that the engine and transmission are at normal operating temperature. (Fluid temperature: 70–80°C or 158–176°F)
- Only use the COOL range on the dipstick as a rough reference when the fluid is replaced or the engine does not run.

- Park the vehicle on a level surface, set the parking brake.
- With the engine idling, shift the shift lever into all positions from P to L position and return to P position.

HINT: Depress brake pedal.

- Pull out the transmission dipstick and wipe it clean.
- Push it back fully into the tube.
- Pull it out and check that the fluid level is in the HOT range.

If the level is at the low side, add fluid.

**Fluid type: ATF DEXRON<sup>®</sup> II**

**NOTICE: Do not overfill.**

### 2. CHECK FLUID CONDITION

If the fluid smells burnt or is black, replace it as following procedures.

- Remove the drain plug and drain the fluid.
- Reinstall the drain plug securely.
- With the engine OFF, add new fluid through the oil filler tube.

**Fluid type ATF DEXRON<sup>®</sup> II**

**Capacity:**

**Total: 6.5 liters (6.9 US qts, 5.7 Imp qts)**

**Drain and refill: 2.4 liters (2.5 US qts, 2.1 Imp.qts)**

- Start the engine and shift the shift lever into all positions from P to L position and then shift into P position.
- With the engine idling, check the fluid level. Add fluid up to the COOL level on the dipstick.
- Check the fluid level with the normal operating temperature (70–80°C or 158–176 °F) and add as necessary.

**NOTICE: Do not overfill.**

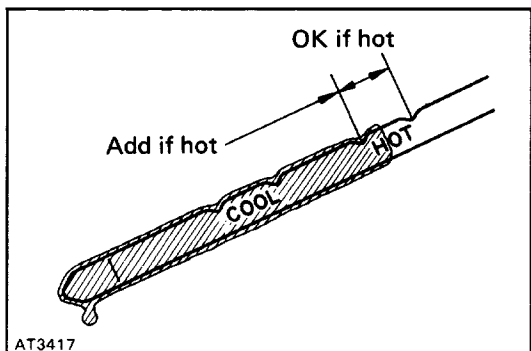
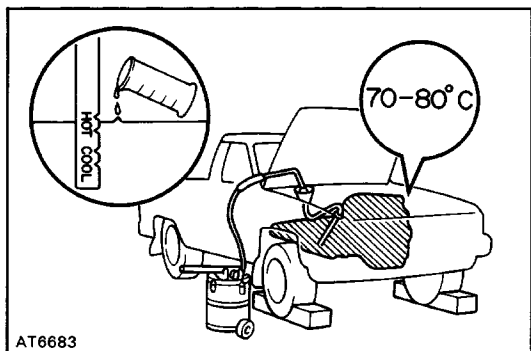
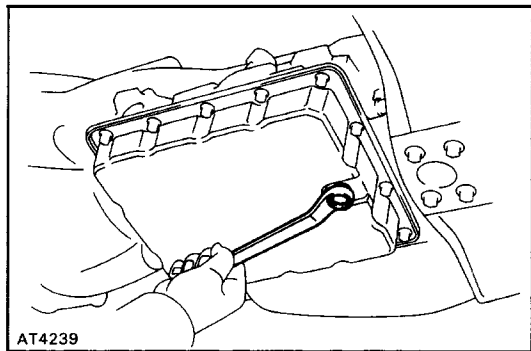
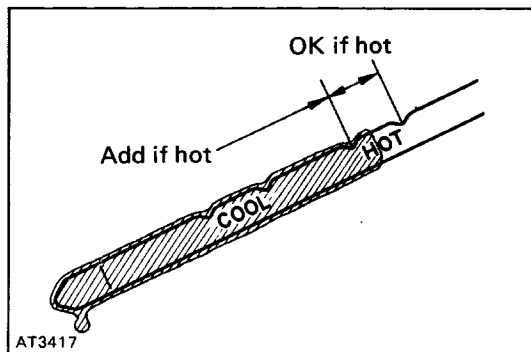

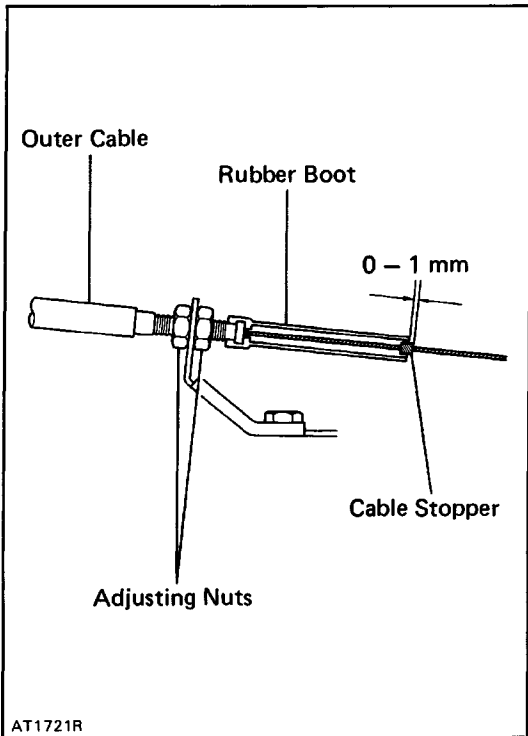

### 3. INSPECT THROTTLE CABLE

(a) Depress the accelerator pedal all the way and check that the throttle valve opens fully.

HINT: If the valve does not open fully, adjust the accelerator cable.

(b) Fully depress the accelerator pedal.

(c) Measure the distance between the end of the boot and stopper on the cable.

**Standard distance: 0–1 mm (0–0.04 in.)**

If the distance is not standard, adjust the cable by the adjusting nuts.

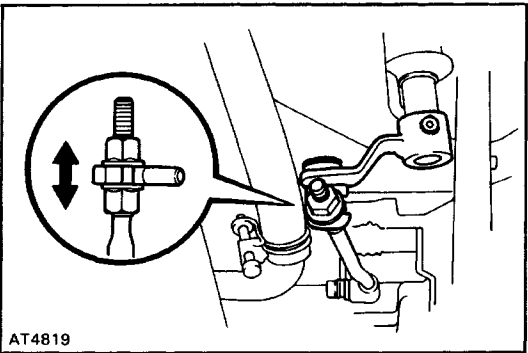

### 4. INSPECT SHIFT LEVER POSITION

When shifting the shift lever from the N position to other positions, check that the lever can be shifted smoothly and accurately to each position and that the position indicator correctly indicates the position.

If the indicator is not aligned with the correct position, carry out the following adjustment procedures.

(a) Remove the nut on the cross shaft rod.

(b) Push the cross shaft rod fully downward.

(c) Return the cross shaft rod three notches to N position.

(d) Set the shift lever to N position.

(e) While holding the shift lever lightly toward the R position side, adjust the cross shaft rod nut.

(f) Tighten the cross shaft rod nut.

(g) Start the engine and make sure that the vehicle moves forward when shifting the lever from the N to D position and reverse when shifting it to the R position.

### 5. INSPECT PARK/ NEUTRAL POSITION SWITCH

Check that the engine can be started with the shift lever only in the N or P position, but not in other positions.

If not as stated above, carry out the following adjustment procedures.

(a) Loosen the park/neutral position switch bolt and set the shift lever to the N position.

(b) Align the groove and neutral basic line.

(c) Hold in position and tighten the bolt.

**Torque: 5.4 N–m (55 kgf–cm, 48 in.lbf)**

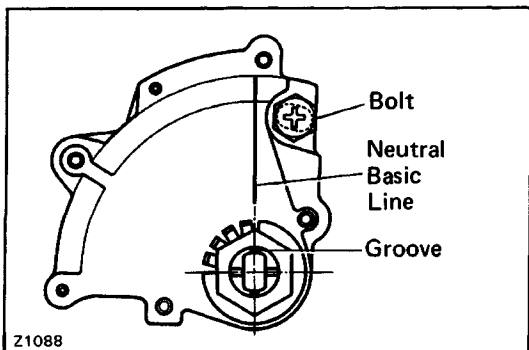

### 6. INSPECT IDLE SPEED (N POSITION)

**Idle speed: 750 RPM**

# Overdrive Control System ELECTRIC CONTROL CIRCUIT

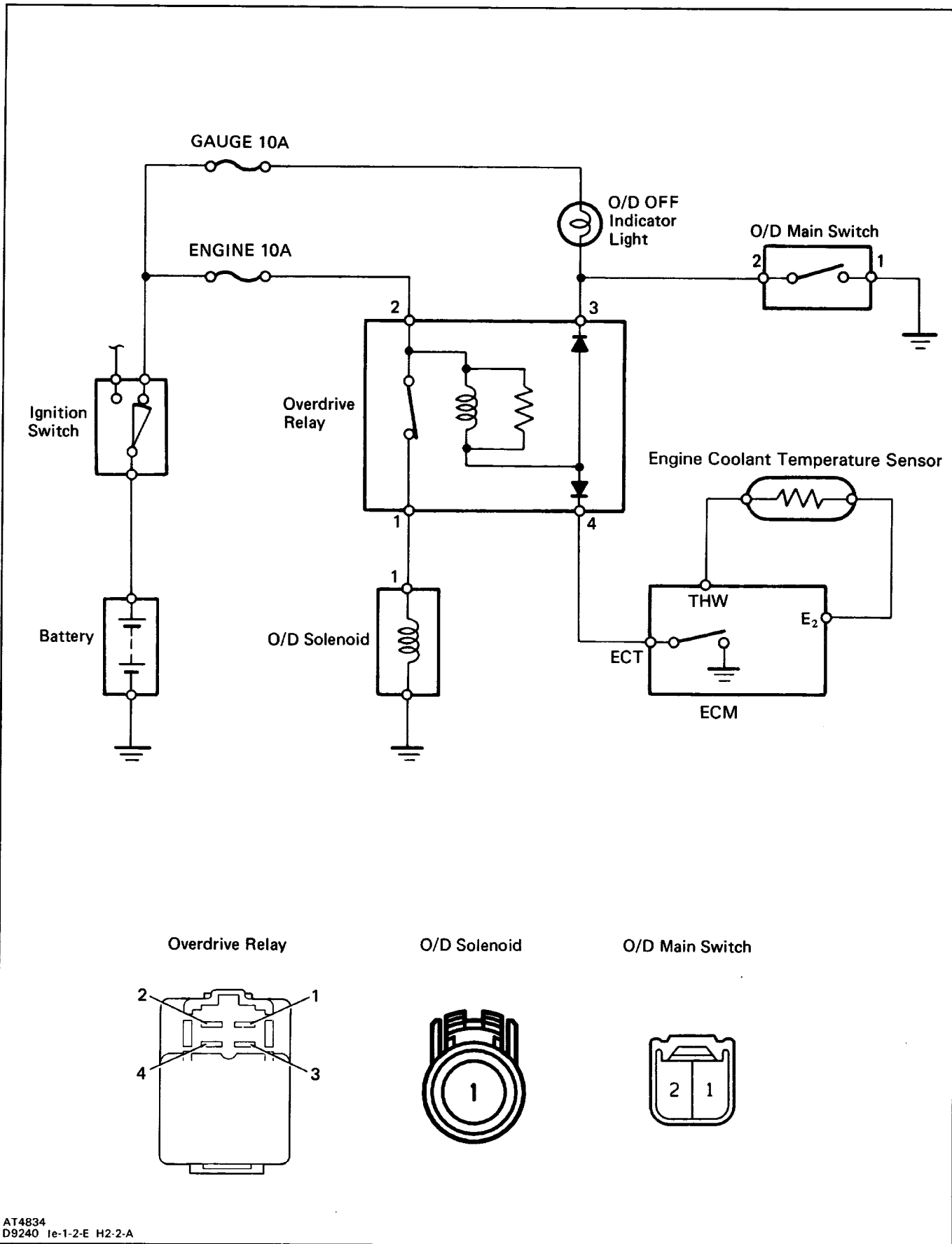

# TROUBLESHOOTING FLOW-CHART

**Trouble: No overdrive engagement with the main switch ON. (After warm-up)**

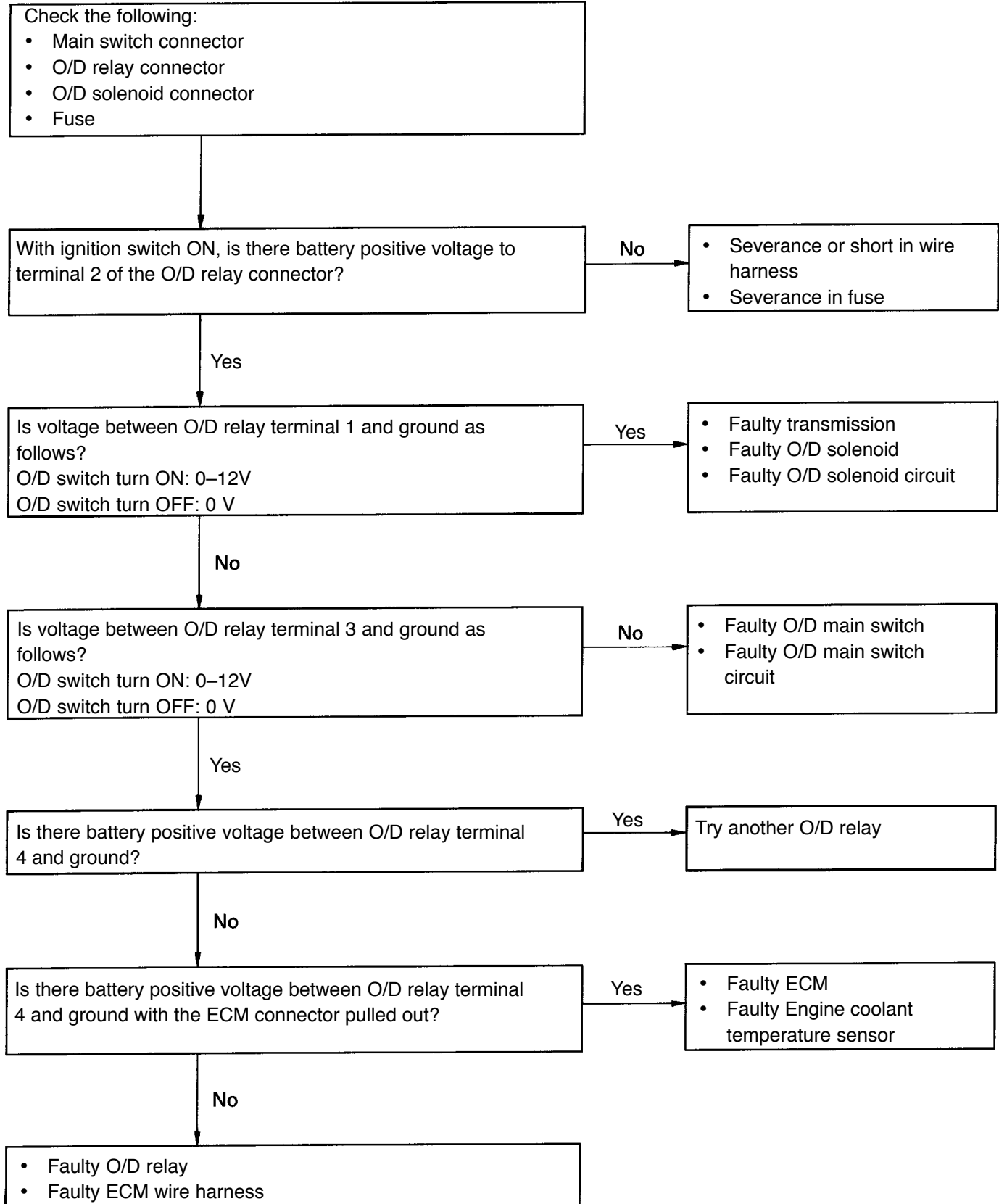

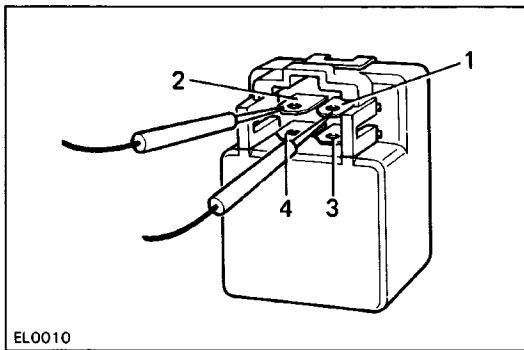

## INSPECTION OF OVERDRIVE CONTROL COMPONENTS

### 1. INSPECT OVERDRIVE RELAY

- (a) Remove the overdrive relay from the pedal bracket.
- (b) Using an ohmmeter, check that there is continuity between terminals 1 and 2.

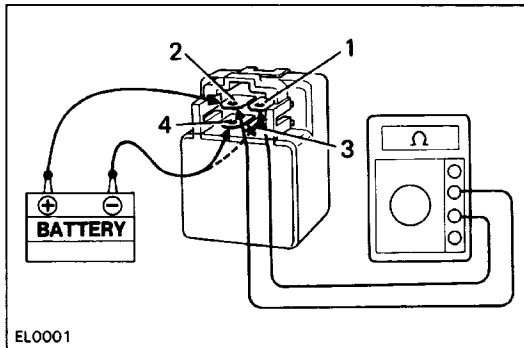

- (c) Apply battery positive voltage to the relay terminals 2 and 3. Using an ohmmeter, check that there is no continuity between terminals 1 and 2.
- (d) Apply battery positive voltage to the relay terminals 2 and 4. Using an ohmmeter, check that there is no continuity between terminals 1 and 2.
- (e) Install the overdrive relay to the pedal bracket.

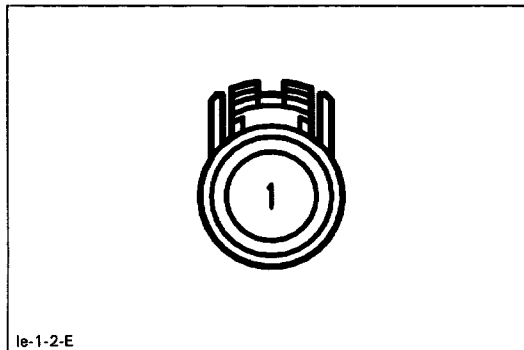

### 2. INSPECT OVERDRIVE SOLENOID

- (a) Using an ohmmeter, measure the resistance between terminal 1 and body.

**Resistance: 11–15 Ω**

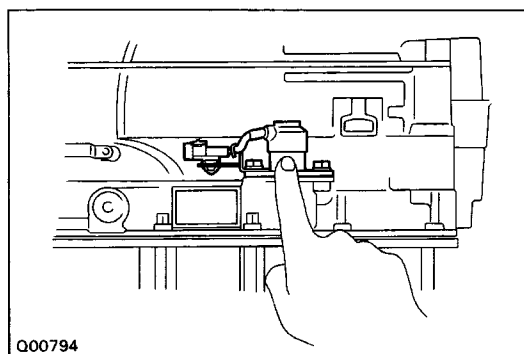

- (b) Apply battery positive voltage to the solenoid. Check that the solenoid operation sound is heard.

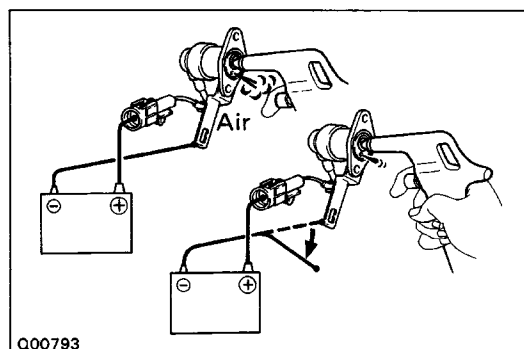

### 3. CHECK SOLENOID SEALS

If there is foreign material in the solenoid valve, there will be no fluid control even with solenoid operation

- (a) Check that the solenoid valve does not leak when low-pressure compressed air is applied.
- (b) When supplying battery positive voltage to the solenoid, check that the solenoid valve opens.

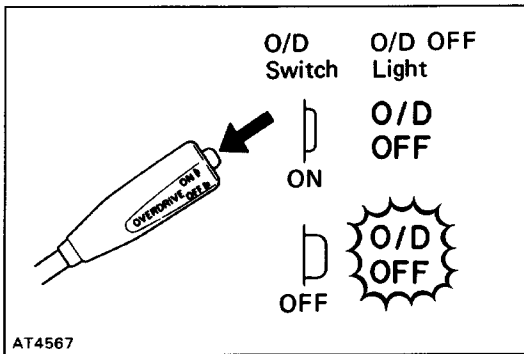

**4. INSPECT-O/D OFF” INDICATOR**

- (a) Turn on the ignition switch.
- (b) Check that the-O/D OFF” indicator does not light, when the O/D main switch is turned ON.
- (c) Check that the-O/D OFF” indicator lights, when the O/D main switch is turned OFF.

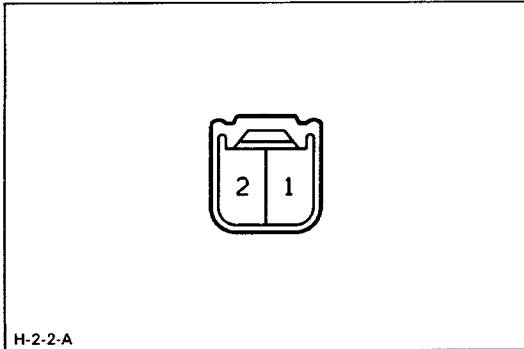

**5. INSPECT OVERDRIVE MAIN SWITCH**

- (a) Remove the steering column cover.
- (b) Using an ohmmeter, check the continuity of the terminals for each switch position.

	Terminal	
SW Position	1	2
ON		
OFF	○ — ○	

**6. INSPECT ENGINE COOLANT TEMPERATURE SENSOR**  
(See page FI-115)



## Mechanical System Tests

### STALL TEST

The objective of this test is to check the overall performance of the transmission and engine by measuring the maximum engine speeds in the D and R positions.

#### NOTICE:

- Perform the test at normal operating fluid temperature (50–80°C or 122–176°F).
- Do not continuously run this test longer than 5 seconds.
- To ensure safety, conduct this test in a wide, clear, level area, which provides good traction.

### MEASURE STALL SPEED

- Check the four wheels and fully apply the parking brake.
- Mount an engine tachometer.
- Keep your left foot pressed firmly on the brake pedal, and start the engine.
- Shift into the D position. Step all the way down on the accelerator pedal with your right foot. Quickly read the highest engine RPM at this time.

**Stall speed: 1,900 ±150 RPM**

- Perform the same test in the R position.

### EVALUATION

- If the engine speed is the same for both positions but lower than specified value:

Engine output may be insufficient

Stator one-way clutch is not operating properly

HINT: If more than 600 RPM below the specified value, the torque converter clutch could be faulty.

- If the stall speed at the D position is higher than specified:

Line pressure too low

Front clutch slipping

No.2 one-way clutch not operating properly

O/D one-way clutch not operating properly

- If the stall speed at the R position is higher than specified:

Line pressure too low

Rear clutch slipping

No.3 brake slipping

O/D one-way clutch not operating properly

- If the stall speed in both R and D positions are higher than specified:

Line pressure too low

Improper fluid level

O/D one-way clutch not operating properly

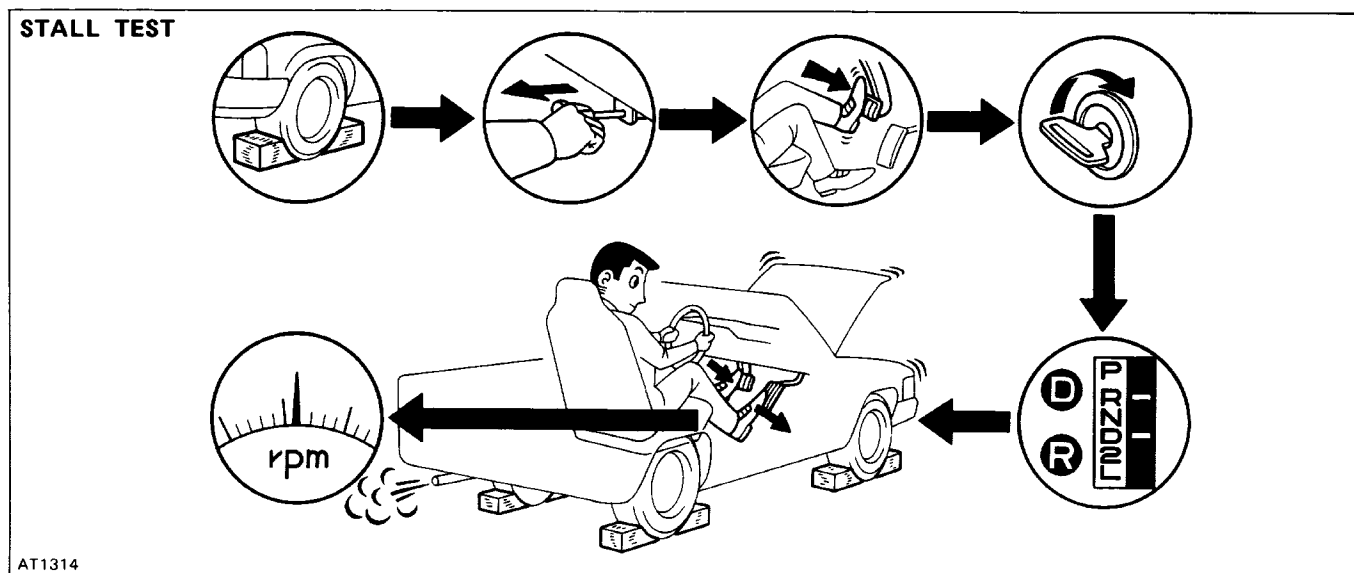

**TIME LAG TEST**

When the shift lever is shifted while the engine is idling, there will be a certain time lapse or lag before the shock can be felt. This is used for checking the condition of the O/D direct clutch, front clutch, rear clutch and No.3 brake.

**NOTICE:**

- Perform the test at normal operating fluid temperature (50–80°C or 122–176°F).
- Be sure to allow one minute interval between tests.
- Make three measurements and take the average value.

**MEASURE TIME LAG**

- Fully apply the parking brake.
- Start the engine and check the idle speed.

**Idle speed: 750 RPM**

**(N position)**

- Shift the shift lever from N to D position. Using a stop watch, measure the time it takes from shifting the lever until the shock is felt.

Time lag: Less than 1.2 seconds

- In same manner, measure the time lag for N–R.

**Time lag: Less than 1.5 seconds**

**EVALUATION**

- If N–D time lag is longer than specified:
  - Line pressure too low
  - Front clutch worn
  - O/D one-way clutch not operating properly
- If N–R time lag is longer than specified:
  - Line pressure too low
  - Rear clutch worn
  - No.3 brake worn
  - O/D one-way clutch not operating properly

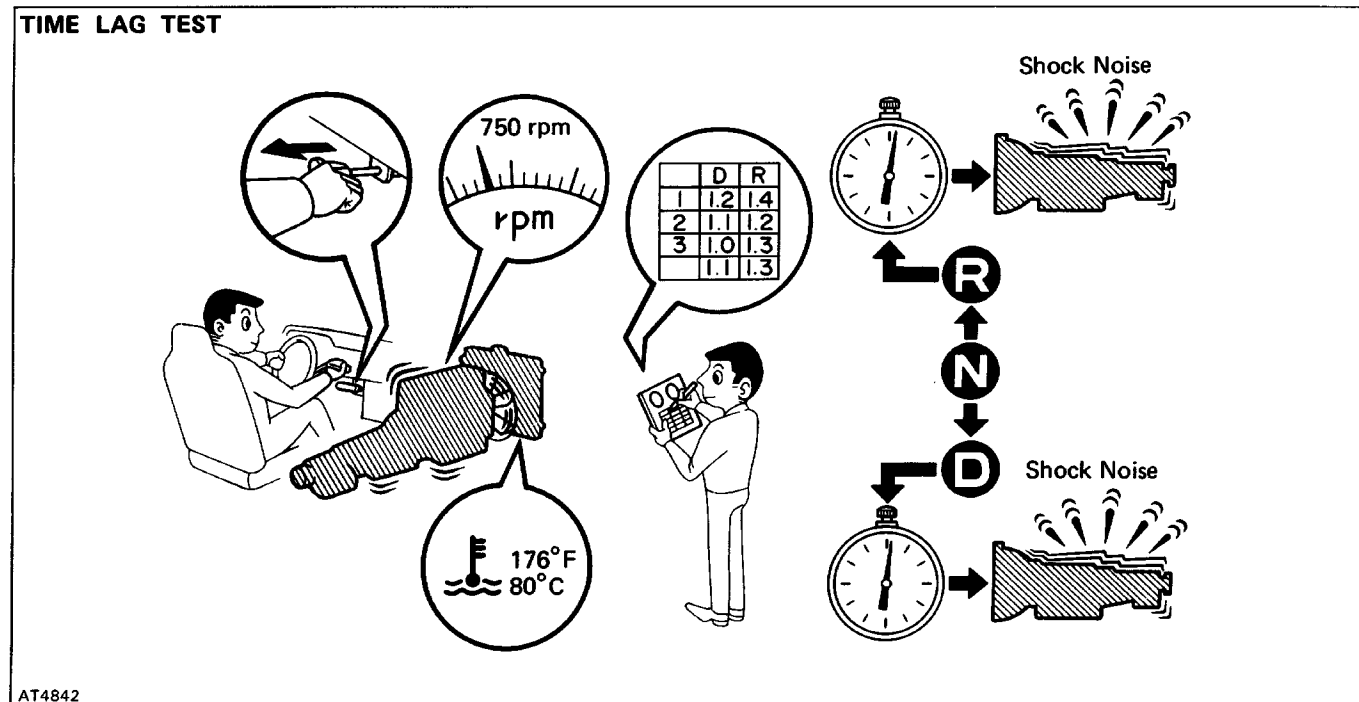

**HYDRAULIC TEST****1. PREPARATION**

- (a) Warm up the transmission fluid.
- (b) Remove the transmission case test plug and connect the hydraulic pressure gauge.  
SST 09992-00094 (Oil pressure gauge)

**NOTICE: Perform the test at normal operating fluid temperature (50–80°C or 122–176°F).**

**2. MEASURE LINE PRESSURE**

- (a) Fully apply the parking brake and chock the four wheels.
- (b) Start the engine and check the idle speed.
- (c) Shift into the D position, keep your left foot pressed firmly on the brake pedal and while manipulating the accelerator pedal with the right foot, measure the line pressure at the engine speeds specified in the table.
- (d) In the same manner, perform the test in the R position.

kPa (kgf/cm<sup>2</sup>,psi)

D position		R position	
Idling	Stall	Idling	Stall
441 – 500 (4.5 – 5.1, 64 – 73)	990 – 1,167 (10.1 – 11.9, 144 – 169)	667 – 745 (6.8 – 7.6, 97 – 108)	1,471 – 1,863 (15.0 – 19.0, 213 – 270)

If the measured pressures are not up to specified values, recheck the throttle cable adjustment and retest.

**EVALUATION**

- (a) If the measured values at all positions are higher than specified:

- Throttle cable out of adjustment
- Throttle valve defective
- Regulator valve defective

- (c) If pressure is low in the D position only:

- D position circuit fluid leakage
- Front clutch defective

- (b) If the measured values at all positions are lower than specified:

- Throttle cable out of adjustment
- Throttle valve defective
- Regulator valve defective
- Oil pump defective
- O/D direct clutch defective

- (d) If pressure is low in the R position only:

- R position circuit fluid leakage
- No.3 brake defective
- Rear clutch defective

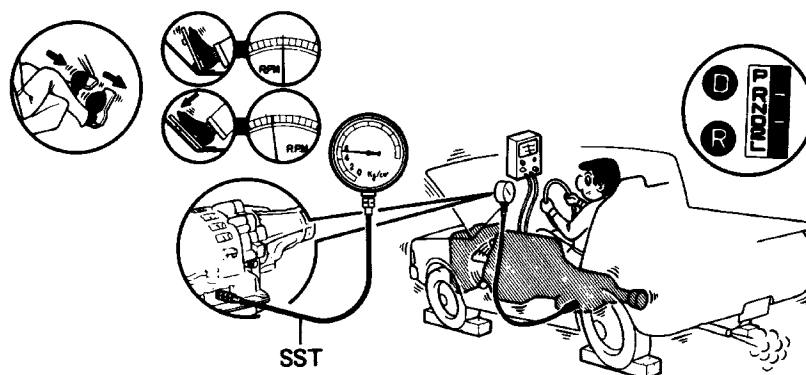
**LINE PRESSURE TEST**

**3. MEASURE GOVERNOR PRESSURE**

- (a) Check the parking brake to see that it is not applied.
- (b) Start the engine.
- (c) Shift into the D position and measure the governor pressure at the speeds specified in the table.

**EVALUATION**

If governor pressure is defective:

- Line pressure defective
- Fluid leakage in governor pressure circuit
- Governor valve operation defective

Output shaft	Vehicle speed (Reference only)		Governor pressure
	P195175R14	P205/75R 14	
1,000 RPM	32 km/h (20 mph)	32 km/h (20 mph)	88 – 147 kPa (0.9 – 1.5 kgf/cm <sup>2</sup> , 13 – 21 psi)
1,800 RPM	57 km/h (35 mph)	58 km/h (36 mph)	157 – 216 kPa (1.6 – 2.2 kgf/cm <sup>2</sup> , 23 – 31 psi)
3,500 RPM	111 km/h (69 mph)	113 km/h (70 mph)	402 – 520 kPa (4.1 – 5.3 kgf/cm <sup>2</sup> , 58 – 75 psi)

**GOVERNOR PRESSURE TEST**

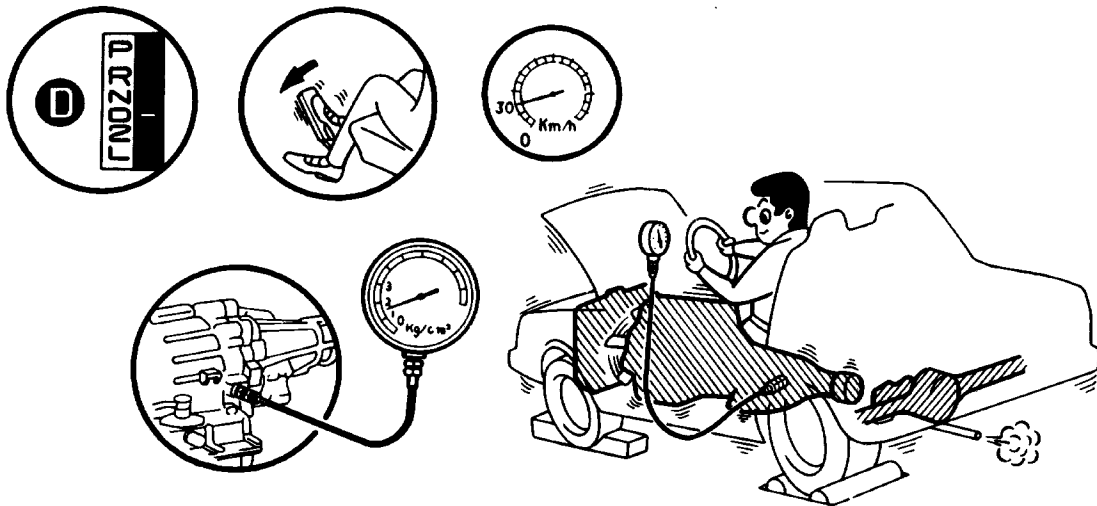

## ROAD TEST

**NOTICE: Perform this test at normal fluid temperature (50–80°C or 122–176°F).**

### 1. D POSITION TEST

Shift into the D position and while driving with the accelerator pedal held constant at the throttle valve full open and the O/D switch ON, check on the following points:

(a) Check to see that the 1–2, 2–3 and 3–O/D up-shifts take place and also that the shift points conform to those shown in the automatic shift schedule.

HINT: 3–O/D up-shift does not take place with a throttle valve opening of more than 86% or engine coolant temperature below 50°C (122°F).

#### EVALUATION

- (1) If there is no 1–2 up-shift:
  - Governor valve is defective
  - 1–2 shift valve is stuck
- (2) If there is no 2–3 up-shift:
  - 2–3 shift valve is stuck
- (3) If there is no 3–O/D up-shift (throttle valve opening less than 86%):
  - 3–4 shift valve is stuck
  - Solenoid valve or circuit defective
- (4) If the shift point is defective:
  - Throttle cable out of adjustment
  - Throttle valve, 1–2 shift valve, 2–3 shift valve, 3–4 shift valve etc., are defective

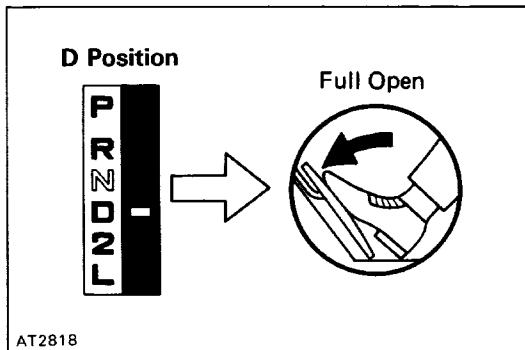

AT2818

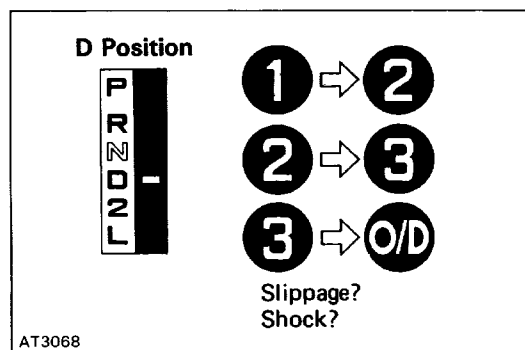

AT3068

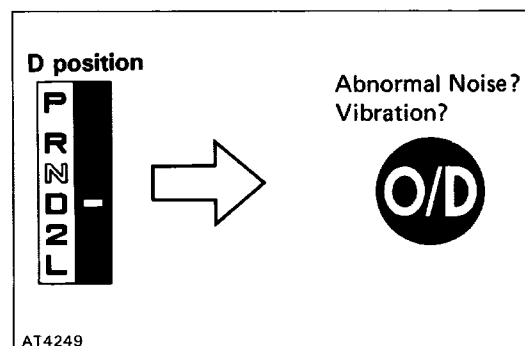

AT4249

- (b) In the same manner, check the shock and slip at 1–2, 2–3 and 3–O/D up-shifts.

#### EVALUATION

If the shock is excessive:

- Line pressure is too high
- Accumulator is defective

- (c) Run in the 3rd gear or O/D of D position and check for abnormal noise and vibration.

HINT: Check for cause of abnormal noise and vibration must be made with extreme care as they could also be due to unbalance in the propeller shaft, differential, tires, torque converter clutch, etc.

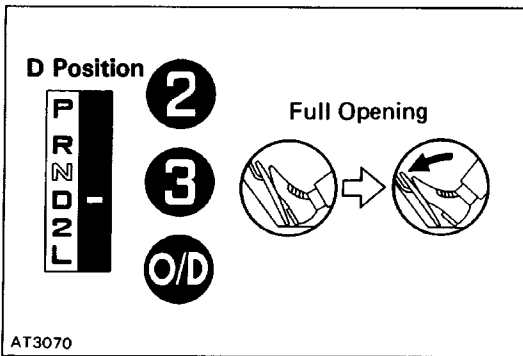

(d) While running in the D position, 2nd, 3rd and O/D gears, check to see that the possible kick-down vehicle speed limits for 2-1, 3-2 and O/D-3 kick-downs conform to those indicated on the automatic shift schedule.

HINT: O/D-3 kick-down is always possible with a throttle valve opening of more than 86%.

(e) Check for abnormal shock and slip at kick-down.

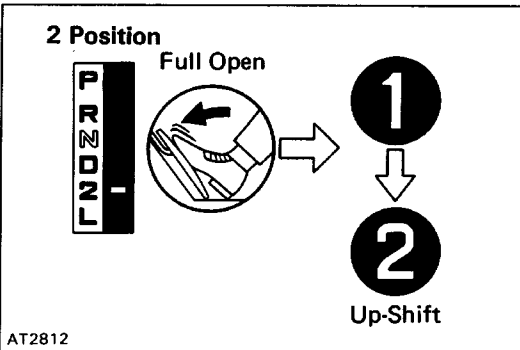

**2. 2 POSITION TEST**

Shift into the 2 position and, while driving with the accelerator pedal held constantly at the full throttle valve opening position, check on the following points:

(a) Check to see that the 1-2 up-shift takes place and that the shift point conforms to it shown on the automatic shift schedule.

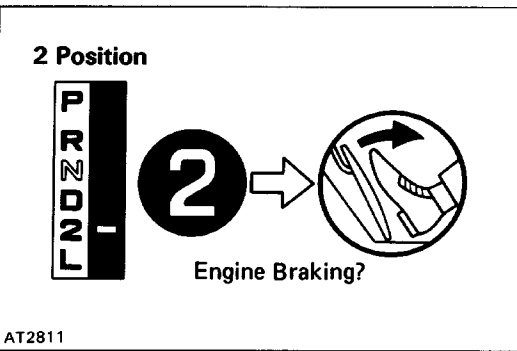

(b) While running in the 2 position and 2nd gear, release the accelerator pedal and check the engine braking effect.

**EVALUATION**

If there is no engine braking effect:

- No. 1 brake is defective

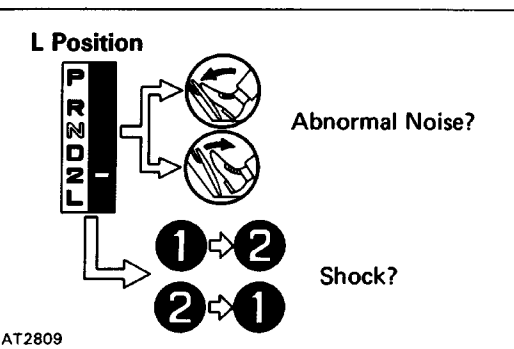

(c) Check for abnormal noise at acceleration and deceleration, and for shock at up-shift and down-shift.

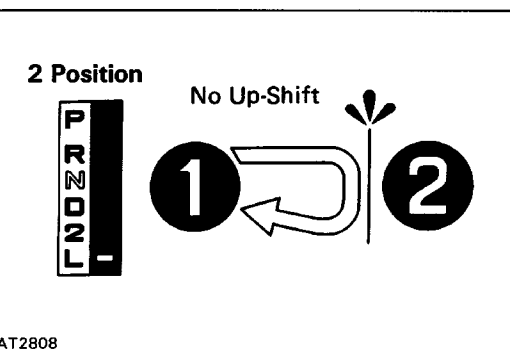

**3. L POSITION TEST**

(a) While running in the L position, check to see that there is no up-shift to 2nd gear.

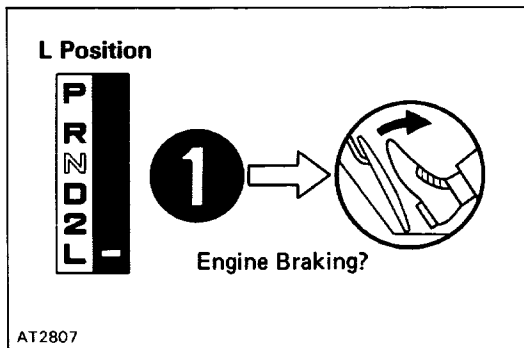

- (b) While running in the L position, release the accelerator pedal and check the engine braking effect.

**EVALUATION**

If there is no engine braking effect:

- No-3 brake is defective

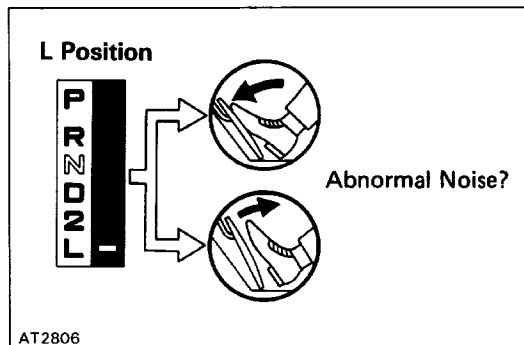

- (c) Check for abnormal noise during acceleration and deceleration.

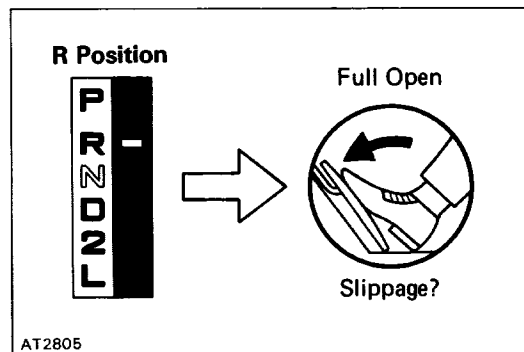

**4. R POSITION TEST**

Shift into the R position and, while starting at wide open throttle, check for slippage.

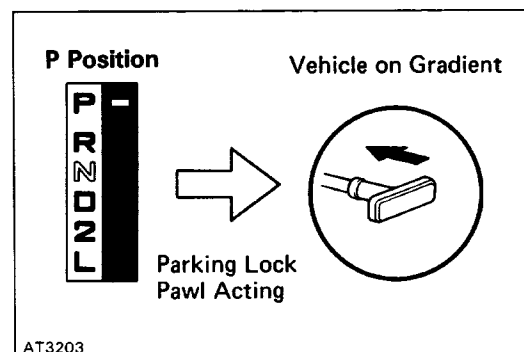

**5. P POSITION TEST**

Stop the vehicle on a gradient (more than 5°) and after shifting into the P position, release the parking brake. Then check to see that the parking lock pawl holds the vehicle in place.

# Automatic Shift Schedule

Throttle valve fully open			→ Fully closed			km/h (mph)
D position (2 position)						L position
1 → 2	2 → 3	[3 → O/D]	O/D → 3	3 → 2	2 → 1	2 → 1
57 - 73 (35 - 45)	106 - 124 (66 - 77)	38 - 52 (24 - 32)	*	95 - 112 (59 - 70)	36 - 49 (22 - 30)	46 - 62 (29 - 39)

\* O/D-<sub>2</sub> 3 down-shift is possible up to maximum speed.

## Park Neutral Position Switch INSPECTION OF PARK/NEUTRAL POSITION SWITCH

Inspect that there is continuity between each terminals.

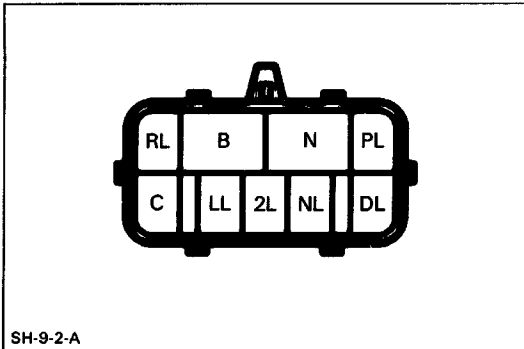

SH-9-2-A

Terminal Shift Position	B	N	PL	RL	NL	DL	2L	LL	C
P	○—○	○—○	○—○	○—○	○—○	○—○	○—○	○—○	○—○
R				○—○	○—○	○—○	○—○	○—○	○—○
N	○—○	○—○			○—○	○—○	○—○	○—○	○—○
D						○—○	○—○	○—○	○—○
2							○—○	○—○	○—○
L								○—○	○—○



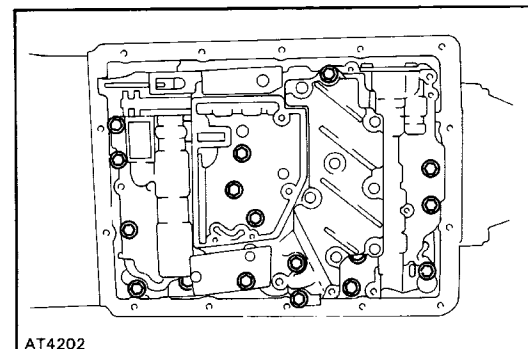
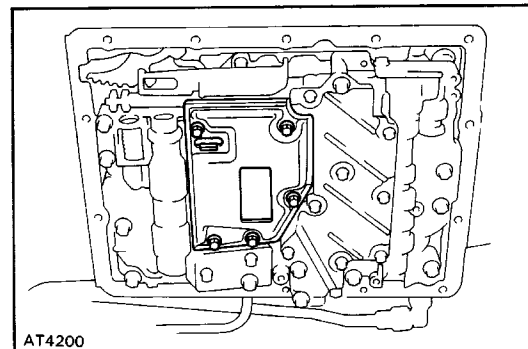
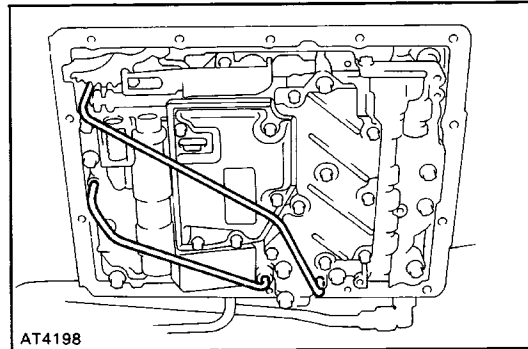
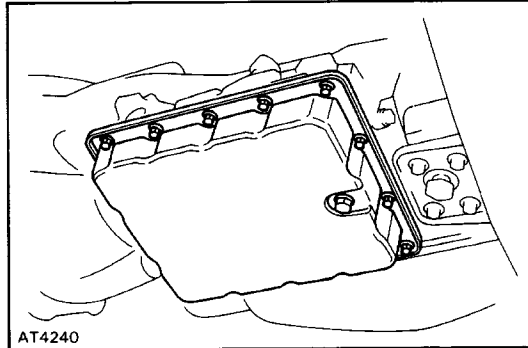
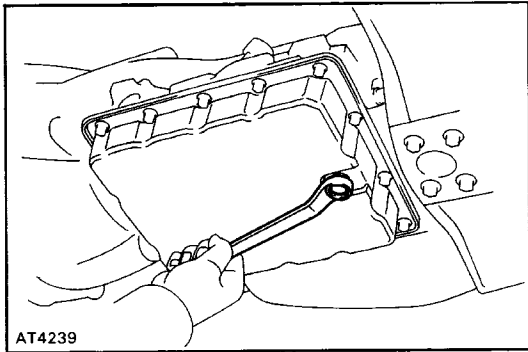

## ON-VEHICLE REPAIR

### Valve Body

#### REMOVAL OF VALVE BODY

##### 1. CLEAN TRANSMISSION EXTERIOR

To prevent contamination, clean the exterior of the transmission.

##### 2. DRAIN TRANSMISSION FLUID

Remove the drain plug and the fluid into a suitable container.

##### 3. REMOVE OIL PAN, FILLER TUBE AND GASKET

**NOTICE:** Some fluid will remain in the oil pan. Be careful not to damage the filler tube and O-ring.

Remove all pan bolts, and carefully remove the pan assembly. Discard the gasket.

##### 4. REMOVE OIL TUBES

Pry up both tube ends with a large screwdriver and remove the tubes.

##### 5. REMOVE OIL STRAINER

Remove the six bolts, and the oil strainer.

**NOTICE:** Be careful as some oil will come out with the filter.

##### 6. REMOVE VALVE BODY

(a) Remove the seventeen bolts.

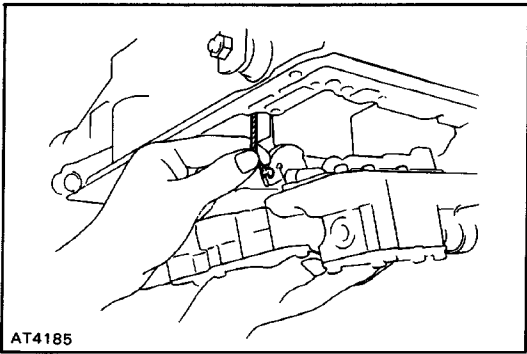

(b) Disconnect the throttle cable from the cam and remove the valve body.

## INSTALLATION OF VALVE BODY

### 1. CONNECT THROTTLE CABLE TO CAM

Push the cable fitting into the cam.

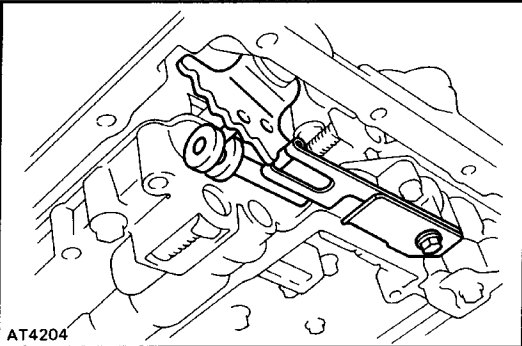

### 2. INSTALL VALVE BODY

(a) Align the manual valve lever with the manual valve.

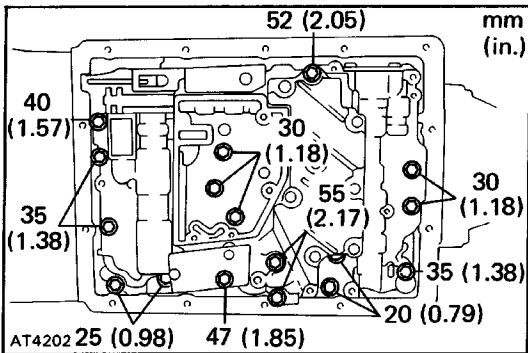

(b) Finger tighten the all bolts first. Then tighten the bolts evenly.

HINT: Each bolt length (mm, in.) is indicated in the figure.

**Torque: 10 N-m (100 kgf-cm, 7 ft-lbf)**

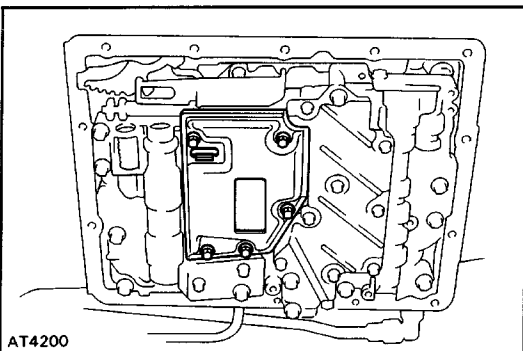

### 3. INSTALL OIL STRAINER

Be sure the screen is clean. Torque the bolts.

**Torque: 5.4 N-m (55 kgf-cm, 48 in.·lbf)**

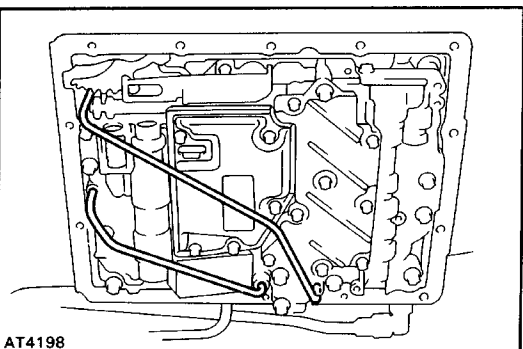

### 4. INSTALL OIL TUBES

Tap the tubes with a plastic hammer to install them into the positions in the figure.

**NOTICE: Be careful not to bend or damage the tubes.**

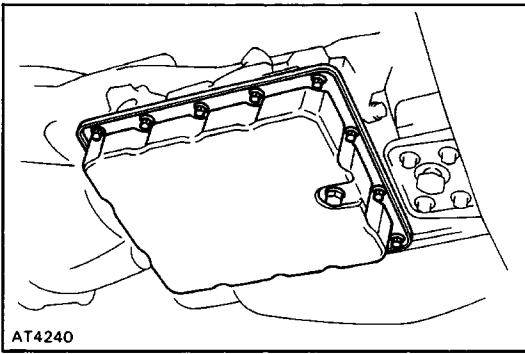

#### 5. INSTALL PAN WITH NEW GASKET

Be sure the pan is clean and the two magnets are in place.

**NOTICE: Do not use gasket sealer.**

Tighten the bolts evenly.

**Torque: 5.4 N-m (55 kgf-cm, 48 in.·lbf)**

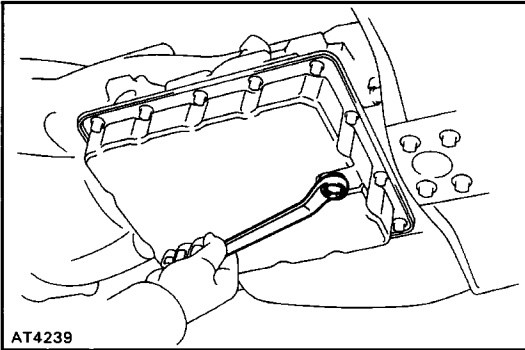

#### 6. INSTALL DRAIN PLUG

Torque the drain plug.

**Torque: 20 N-m (205 kgf-cm, 15 ft-lbf)**

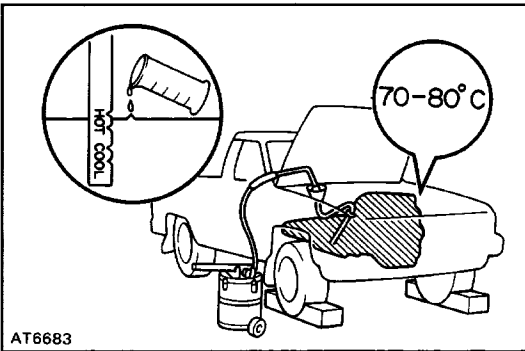

#### 7. FILL TRANSMISSION WITH ATF

Add only about two liters of ATF. Start the engine and shift through all the positions. Check the fluid level and add as necessary.

**NOTICE: Do not overfill.**

**Fluid type: ATF DEXRON<sup>®</sup>III**

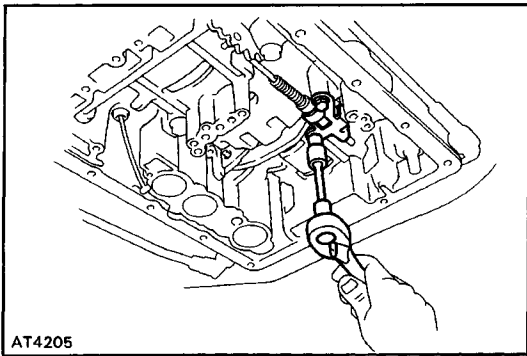

## Parking Lock Pawl

### REMOVAL OF PARKING LOCK PAWL

1. REMOVE VALVE BODY (See page [AT-28](#))
2. REMOVE PARKING LOCK PAWL BRACKET  
Remove the two bolts and the bracket.

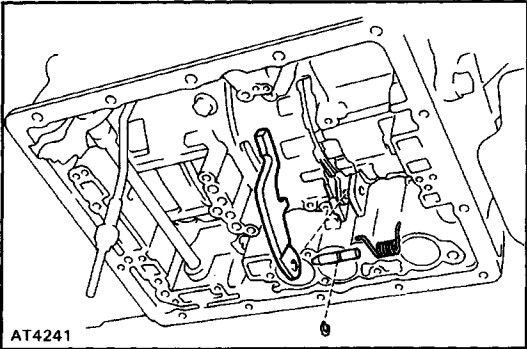

3. REMOVE SPRING FROM PARKING LOCK PAWL PIVOT PIN

4. REMOVE PIVOT PIN AND PARKING LOCK PAWL

### INSTALLATION OF PARKING LOCK PAWL

1. INSTALL PARKING LOCK PAWL AND PIVOT PIN
2. INSTALL SPRING

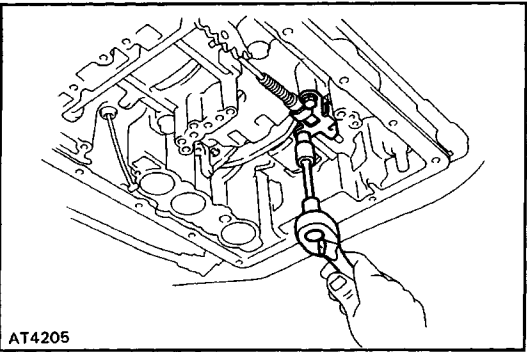

3. INSTALL VALVE BODY (See page [AT-29](#))

- (a) Push lock rod fully toward.
- (b) Install the two bolts finger tight
- (c) Check that the pawl operates smoothly.
- (d) Torque the bolts.

Torque: 7.4 N.m (75 kgf.cm, 65 in.·lbf)

4. INSTALL VALVE BODY (See page [AT-29](#))

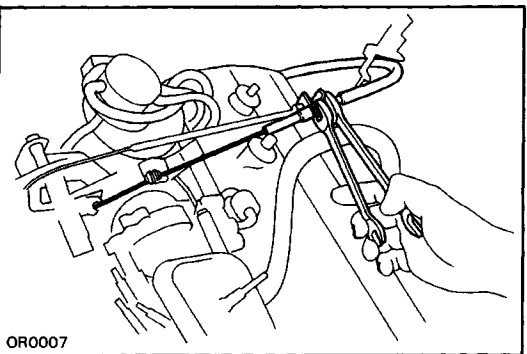

## Throttle Cable

### REMOVAL OF THROTTLE CABLE

1. DISCONNECT THROTTLE CABLE

- (a) Disconnect the cable housing from the bracket.
- (b) Disconnect the cable from the throttle linkage.

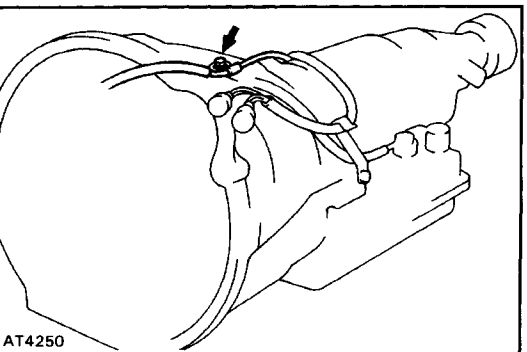

- (c) Disconnect the cable from the torque converter clutch housing.

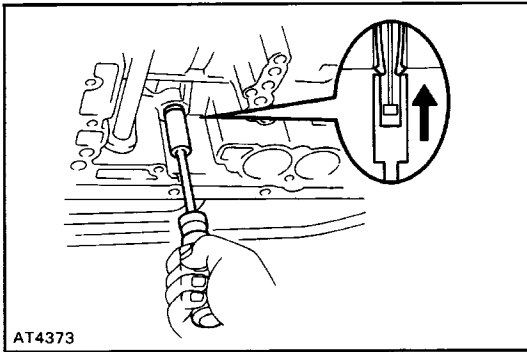

AT4373

2. REMOVE VALVE BODY (See page [AT-28](#))
3. PUSH THROTTLE CABLE OUT OF TRANSMISSION CASE  
Using a 10-mm socket, push the throttle cable out.

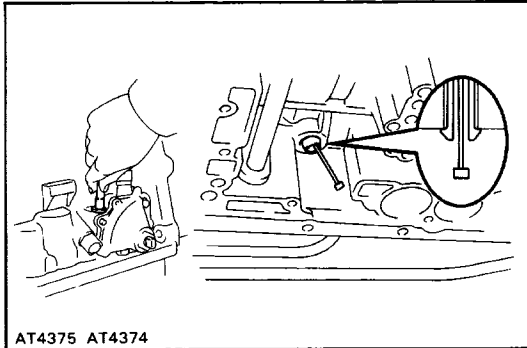

AT4375 AT4374

## INSTALLATION OF THROTTLE CABLE

1. INSTALL CABLE IN TRANSMISSION CASE  
Be sure to push it in all the way.
2. INSTALL VALVE BODY (See page [AT-29](#))

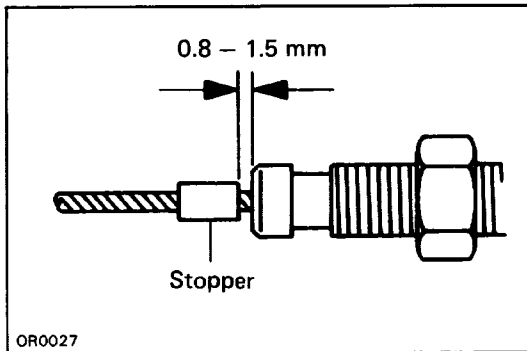

OR0027

3. IF THROTTLE CABLE IS NEW, STAKE STOPPER ON INNER CABLE

- (a) Pull the inner cable lightly until a slight resistance is felt, and hold it.
- (b) Stake the stopper as shown, 0.8–1.5 mm (0.031–0.059 in.) in width.

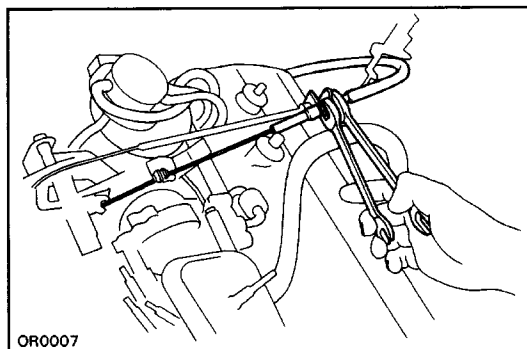

OR0007

4. CONNECT THROTTLE CABLE

- (a) Connect the cable to the throttle linkage.
- (b) Connect the cable housing to the bracket.
- (c) Connect the cable to the torque converter clutch housing.

5. ADJUST THROTTLE CABLE (See page [AT-15](#))
6. TEST DRIVE VEHICLE

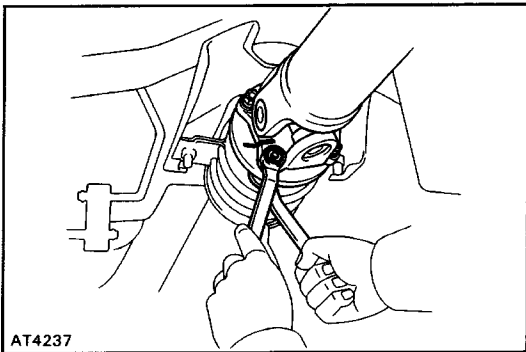

## Extension Housing REPLACEMENT OF OIL SEAL

1. RAISE VEHICLE, AND POSITION PAN TO CATCH ANY FLUID THAT MAY DRIP
2. REMOVE PROPELLER SHAFT

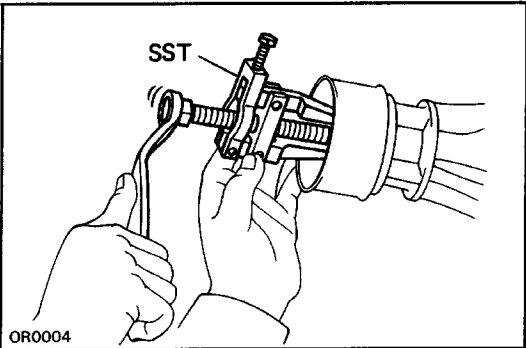

3. REMOVE REAR OIL SEAL  
**NOTICE:** Clean the rear extension housing before removing the seal.

Using SST, remove the oil seal.  
SST 09308-10010

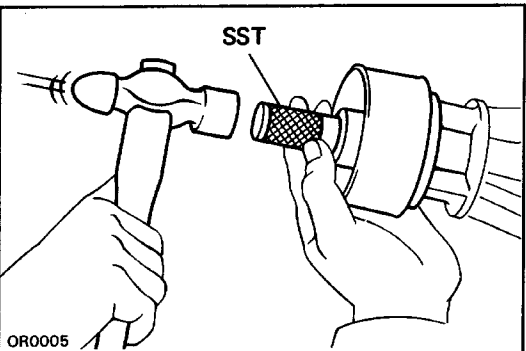

4. INSTALL NEW OIL SEAL

Using SST, drive in a new oil seal as far as it will go.  
SST 0932 5-20010

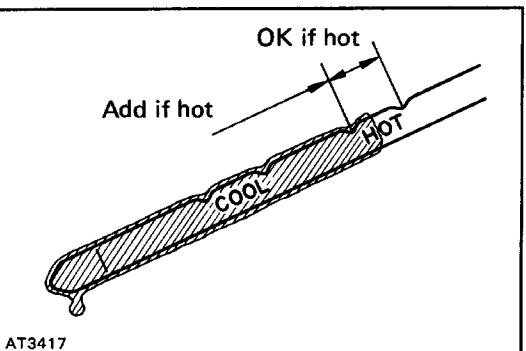

5. INSTALL PROPELLER SHAFT
6. LOWER VEHICLE AND CHECK FLUID LEVEL  
Start the engine, shift the shift lever into each position and, then check the fluid level with the transmission in P position.  
Add fluid as necessary.  
**NOTICE:** Do not overfill.  
Fluid type: ATF DEXRON<sup>®</sup> II

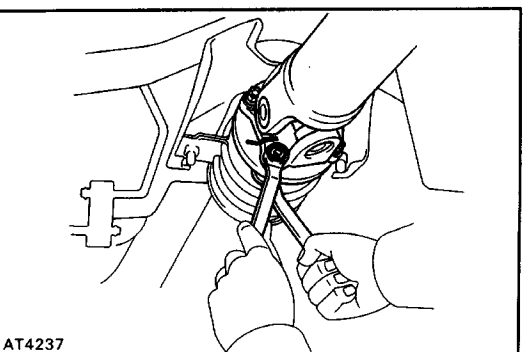

## REMOVAL OF EXTENSION HOUSING

1. RAISE VEHICLE AND POSITION PAN TO CATCH ANY FLUID THAT MAY DRIP
2. REMOVE PROPELLER SHAFT

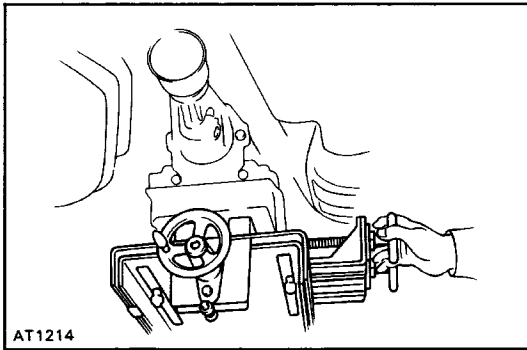

### 3. JACK UP TRANSMISSION SLIGHTLY

Securely support the transmission on a transmission jack. Lift the transmission slightly to remove weight from the rear support member.

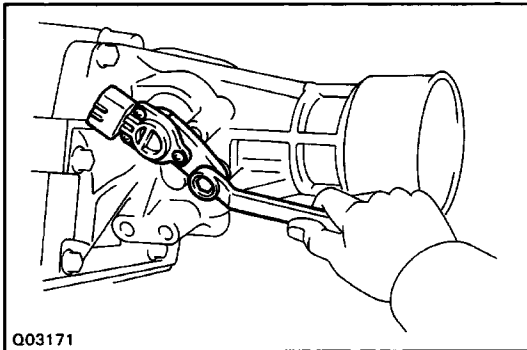

### 4. DISCONNECT CONNECTOR

### 5. REMOVE NO. 1 VEHICLE SPEED SENSOR

- (a) Remove the bolt and the vehicle speed sensor.
- (b) Remove the O-ring from the sensor.

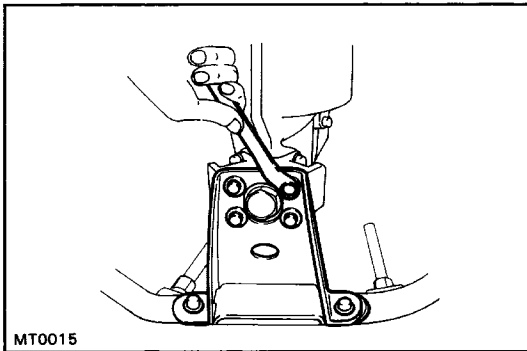

### 6. DISCONNECT ENGINE REAR MOUNTING FROM BRACKET

Remove four bolts from the bracket.

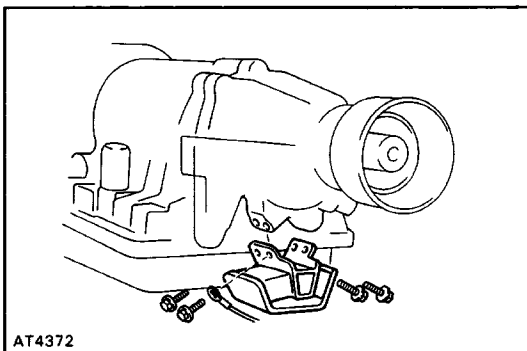

### 7. REMOVE ENGINE REAR MOUNTING FROM EXTENSION HOUSING

Remove four bolts and the engine rear mounting from the extension housing.

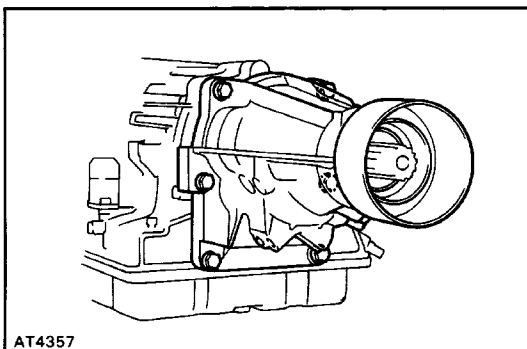

### 8. REMOVE EXTENSION HOUSING AND GASKET

Remove the six bolts. If necessary, tap the extension housing with a plastic hammer or wooden block to loosen it.

## INSTALLATION OF EXTENSION HOUSING

### 1. INSTALL NEW GASKET AND EXTENSION HOUSING ON TRANSMISSION

- (a) Clean the threads of the  $\frac{1}{2}$ " bolt and bolt hole.
- (b) Coat the threads of the  $\frac{1}{2}$ " bolt with sealant.

**Sealant: Part No. 08833-00080, THREE BOND 1344, LOCTITE 242 or equivalent**

- (c) Install the extension housing over a new gasket with bolts, and then torque them.

**HINT:** The two lower bolts are shorter.

**Torque: 34 N-m (345 kgf-cm, 25 ft-lbf)**

### 2. INSTALL ENGINE REAR MOUNTING

- (a) Install the engine rear mounting to the extension housing. Tighten the four bolts.

**Torque: 25 N-m (250 kgf-cm, 18 ft-lbf)**

- (b) Lower and rest the transmission on the mounting bracket.

- (c) Connect the mounting to the bracket. Tighten the four bolts.

**Torque: 13 N-m (130 kgf-cm, 9 ft-lbf)**

### 3. INSTALL PROPELLER SHAFT

### 4. INSTALL NO. 1 VEHICLE SPEED SENSOR

- (a) Install a new O-ring on the sensor.
- (b) Install the vehicle speed sensor with the bolt.

### 5. CONNECT CONNECTOR

### 6. LOWER VEHICLE AND CHECK FLUID LEVEL

Start the engine, shift the shift lever into each position, and then check the fluid level with the transmission in P position.

Add fluid as necessary.

**NOTICE: Do not overfill.**

**Fluid type: ATF DEXRON<sup>®</sup> II**

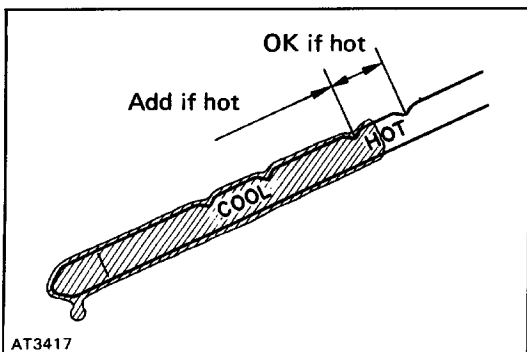
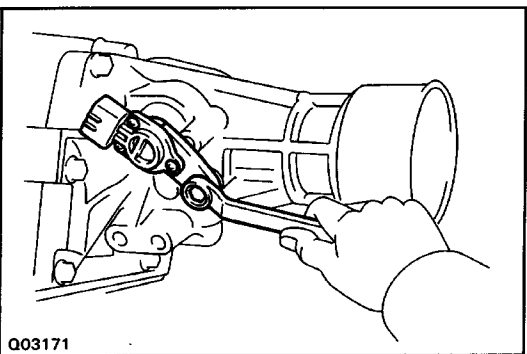
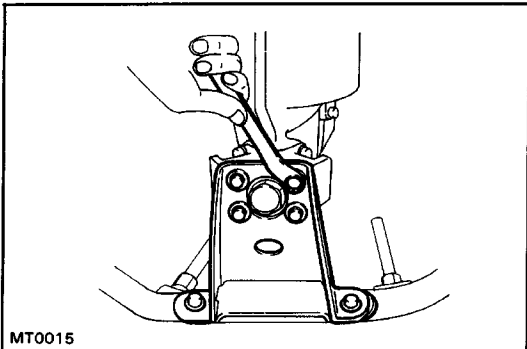
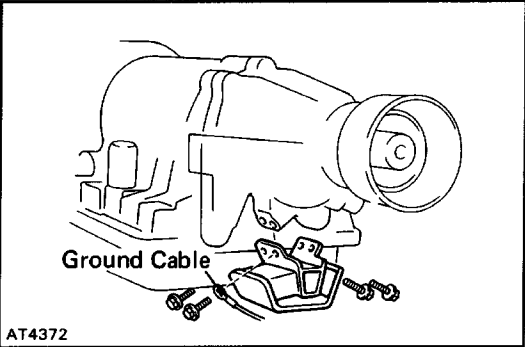
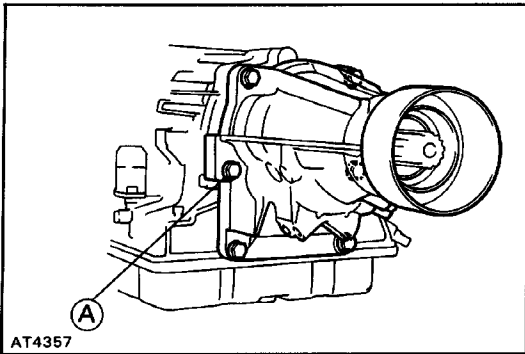



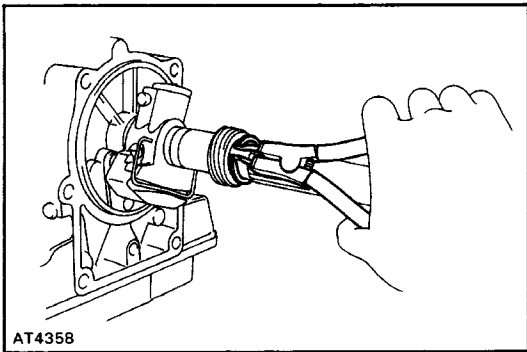

## Governor Body

### REMOVAL OF GOVERNOR BODY

#### 1. REMOVE EXTENSION HOUSING (See page AT-33)

#### 2. REMOVE SPEEDOMETER DRIVE GEAR

- (a) Using snap ring pliers, remove the snap ring.
- (b) Slide off the speedometer gear.
- (e) Remove the lock ball and the outer snap ring.

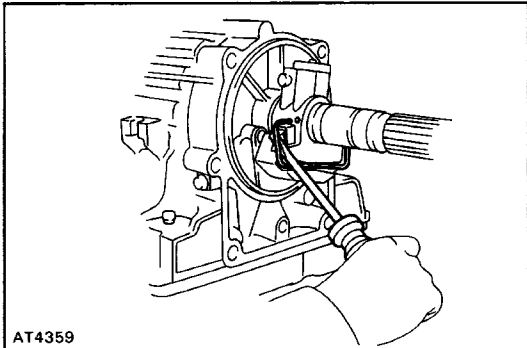

#### 3. REMOVE GOVERNOR FROM OUTPUT SHAFT

- (a) Using a large screwdriver, remove the retaining clip.

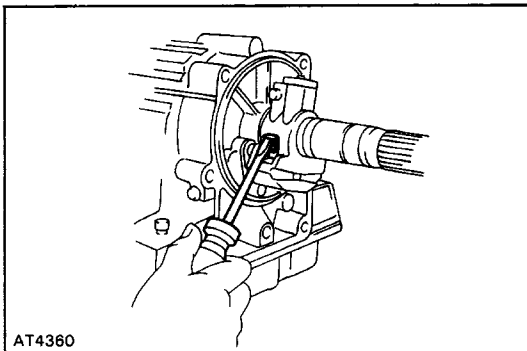

- (b) Unstack the lock plate, remove the bolt and lock plate.

- (c) Remove the governor body.

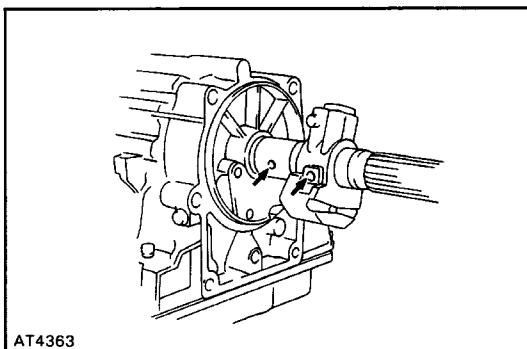

### INSTALLATION OF GOVERNOR BODY

#### 1. INSTALL GOVERNOR ON OUTPUT SHAFT

- (a) Align the governor body and bolt hole on the output shaft.

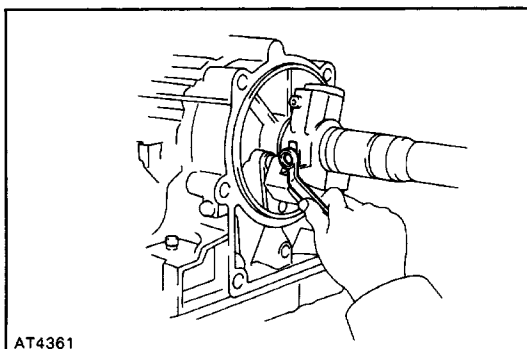

- (b) Install the bolt and lock plate, stake the lock plate.

- (c) Using a large screwdriver, install the retaining clip into the hole in the output shaft.

- (d) Check that the governor assembly is secure.

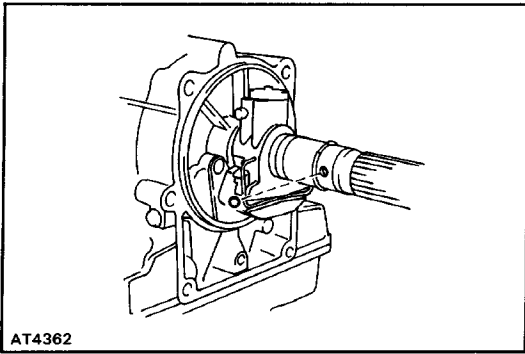

## 2. INSTALL SPEEDOMETER DRIVE GEAR

- (a) Install the snap ring and lock ball.

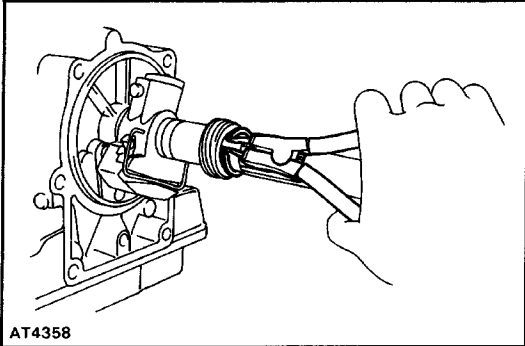

- (b) Slide the speedometer drive gear on the shaft.

- (c) Using snap ring pliers, install the outer snap ring.

## 3. INSTALL EXTENSION HOUSING (See page [AT-34](#))

# REMOVAL AND INSTALLATION OF TRANSMISSION

Remove and install the parts as shown.

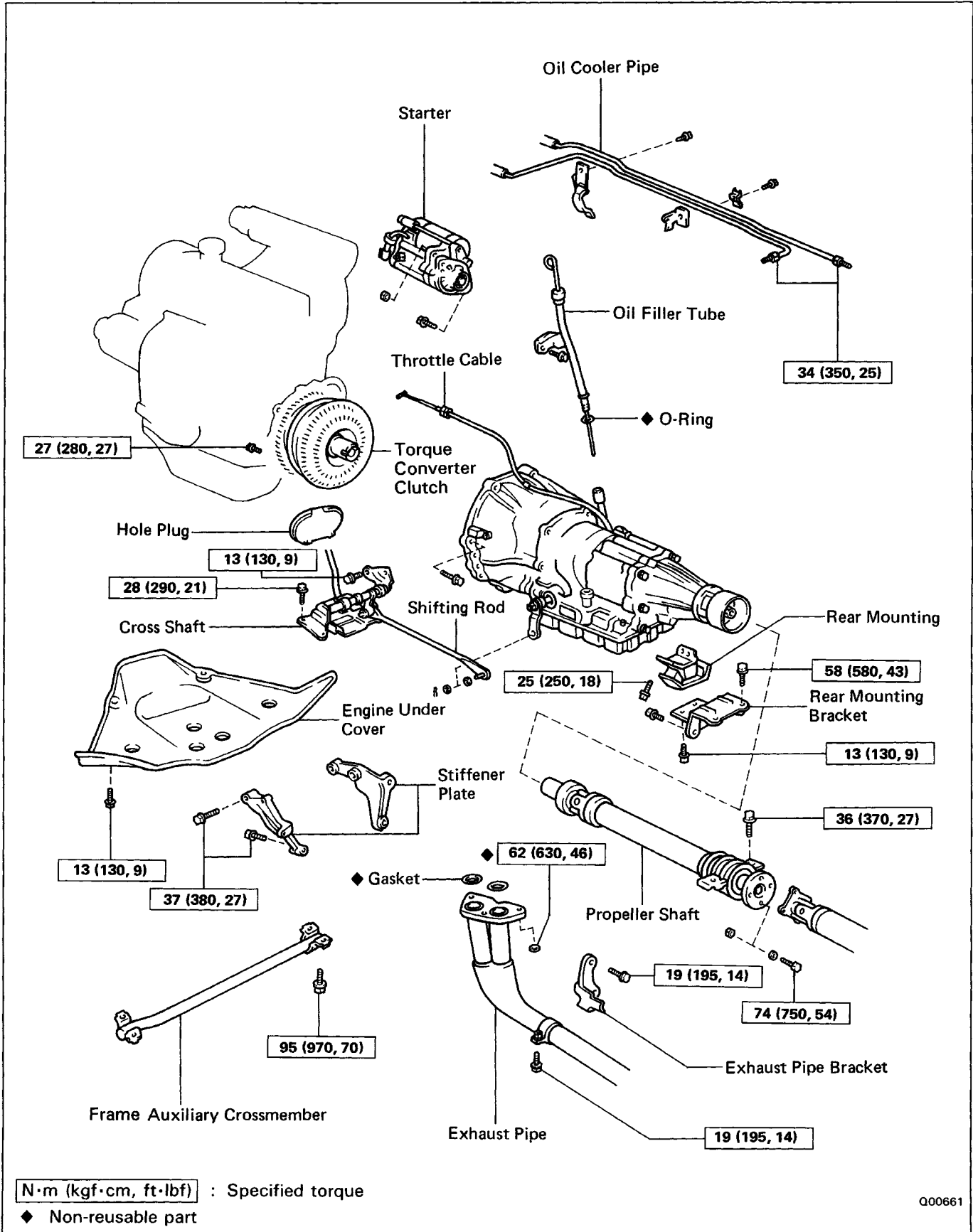

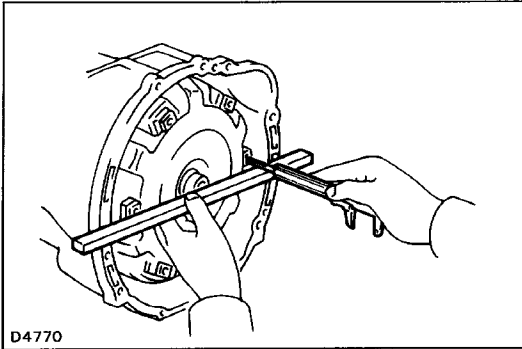

## (MAIN POINT OF INSTALLATION)

### 1. CHECK TORQUE CONVERTER CLUTCH INSTALLATION

Using calipers and a straight edge, measure from the installed surface of the torque converter clutch to the front surface of the transmission housing.

Correct distance: 20.0 mm (0.787 in.)

If the distance is less than the standard, check for an improper installation.

### 2. ADJUST TRANSMISSION THROTTLE CABLE

(See page [AT-15](#))

### 3. FILL TRANSMISSION WITH ATF AND CHECK FLUID LEVEL

Fluid type: ATF DEXRON<sup>®</sup> II

**NOTICE:** Do not overfill.

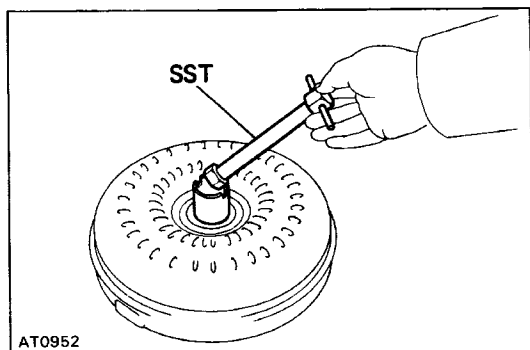

AT0952

## TORQUE CONVERTER CLUTCH AND DRIVE PLATE

### INSPECTION OF TORQUE CONVERTER CLUTCH AND DRIVE PLATE

#### 1. INSPECT ONE-WAY CLUTCH

(a) Install SST into the inner race of the one-way clutch.  
SST 09350-20015 (09397-22020)

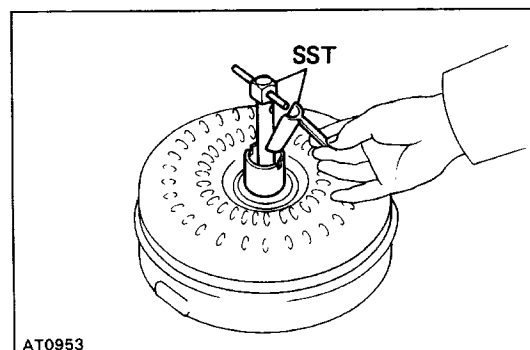

AT0953

(b) Install SST so that it fits in the notch of the converter hub and outer race of the one-way clutch.  
SST 09350-20015 (09397-22020)

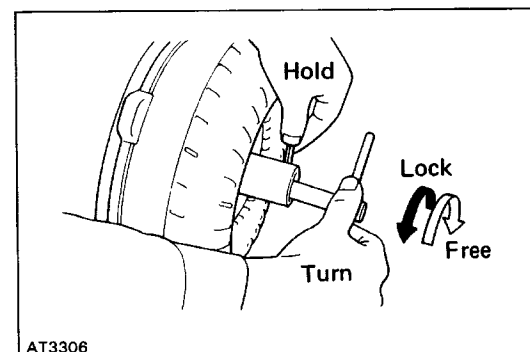

AT3306

(c) With the torque converter clutch standing on its side, the clutch locks when turned counterclockwise, and rotates freely and smoothly clockwise. If necessary, clean the converter and retest the clutch. Replace the converter if the clutch still fails the test.

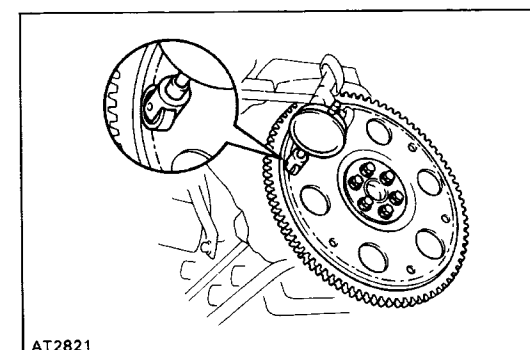

AT2821

#### 2. MEASURE DRIVE PLATE RUNOUT AND INSPECT RING GEAR

Set up a dial indicator and measure the drive plate runout.

If runout exceeds 0.20 mm (0.0079 in.) or if the ring gear is damaged, replace the drive plate. If installing a new drive plate, note the orientation of spacers and tighten the bolts.

**Torque: 83 N-m (850 kgf-cm, 61 ft-lbf)**

#### 3. MEASURE TORQUE CONVERTER CLUTCH SLEEVE RUNOUT

(a) Temporarily mount the torque converter clutch to the drive plate. Set up a dial indicator.

If runout exceeds 0.30 mm (0.0118 in.), try to correct by reorienting the installation of the converter. If excessive runout cannot be corrected, replace the torque converter clutch.

**HINT:** Mark the position of the converter to ensure correct installation.

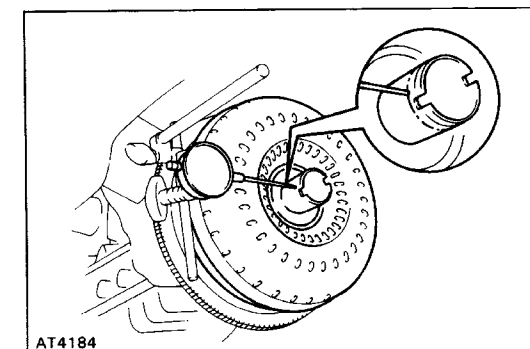

AT4184

(b) Remove the torque converter clutch.

# A340E Automatic Transmission

## DESCRIPTION

### General

The A340E is a 4-speed, Electronic Controlled Transmission developed for use with high-performance engine such as the 3VZ-E. A lock-up mechanism is built into the torque converter clutch.

The A340E automatic transmission is mainly composed of the torque converter clutch, the overdrive (hereafter called O/D) planetary gear unit, 3-speed planetary gear unit, the hydraulic control system and the electronic control system.

Sectional View

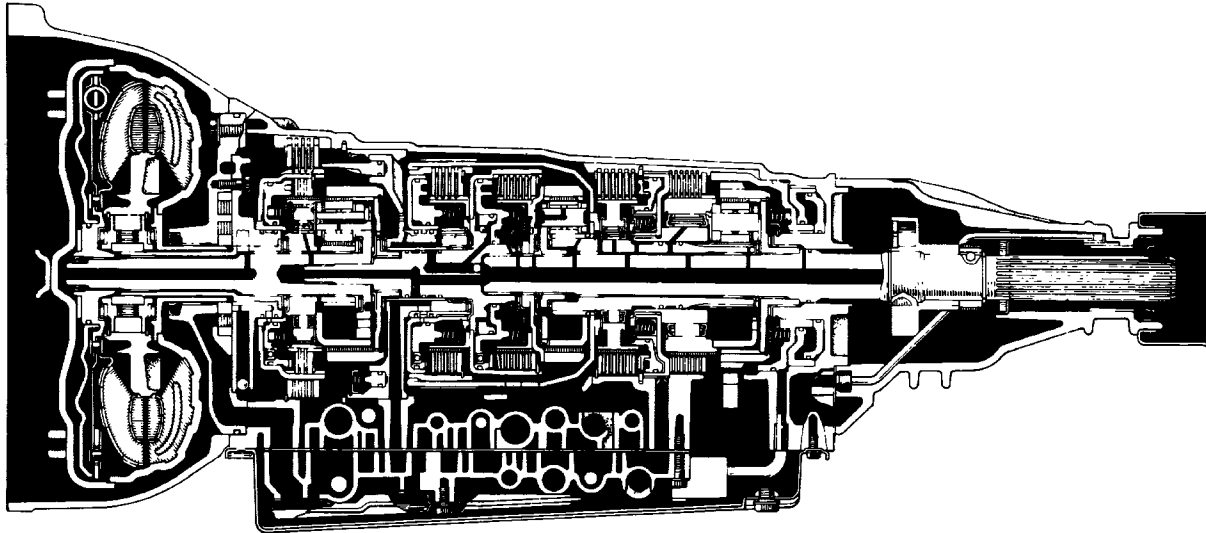

D1328

# General Specifications

Type of Transmission		A340E	
Type of Engine		3VZ-E	
Torque Converter Clutch	Stall Torque Ratio	<b>C&amp;C 2.0 : 1    Others 2.1 : 1</b>	
	Lock-Up Mechanism	<b>Equipped</b>	
Gear Ratio	1 st Gear	<b>2.804</b>	
	2nd Gear	<b>1.531</b>	
	3rd Gear	<b>1.000</b>	
	<b>O/D Gear</b>	<b>0.705</b>	
	Reverse Gear	<b>2.393</b>	
Plates (Disc/Plate)	<b>C<sub>0</sub></b> O/D Direct Clutch	<b>2/2</b>	
	<b>C<sub>1</sub></b> Forward Clutch	<b>5/5</b>	
	<b>C<sub>2</sub></b> Direct Clutch	<b>4/4</b>	
	<b>B<sub>2</sub></b> 2nd Brake	<b>5/5</b>	
	<b>B<sub>3</sub></b> 1 st & Reverse Brake	<b>6/6</b>	
	<b>B<sub>0</sub></b> O/D Brake	<b>4/3</b>	
ATF	Type		<b>ATF DEXRON® II</b>
	Capacity liter (US qts, Imp.qts)	Total	<b>7.2 (7.6, 6.3)</b>
		Drain and Refill	<b>1.6 (1.7, 1.4)</b>



# OPERATION

## Mechanical Operation

### OPERATING CONDITIONS

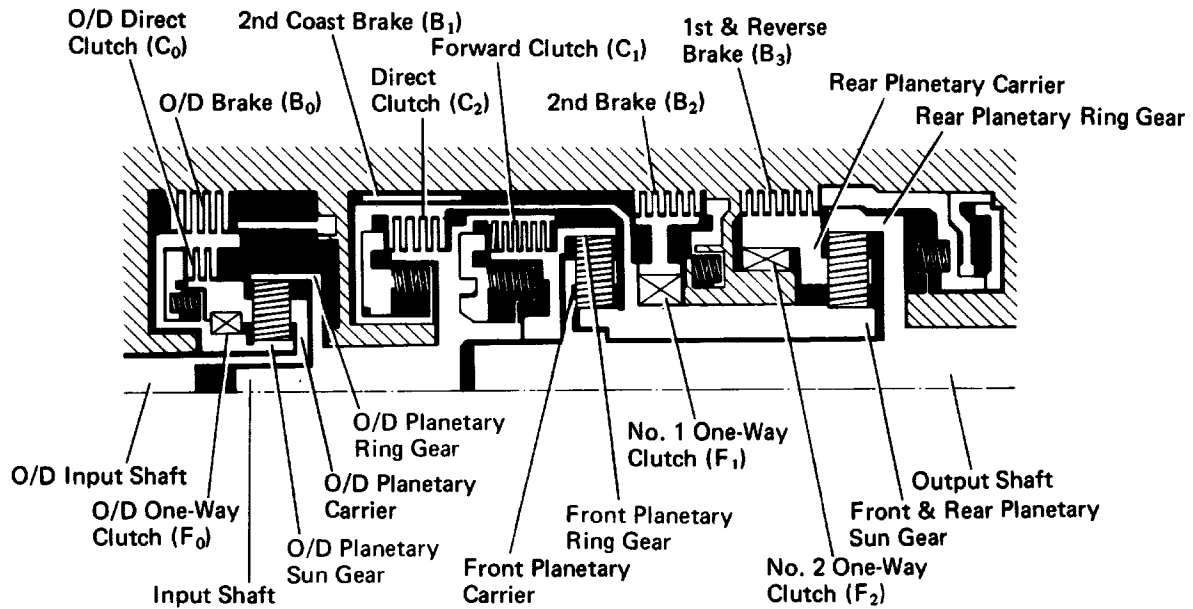

AT2157

○ ..... Operating

Shift lever position	Gear position	C <sub>0</sub>	C <sub>1</sub>	C <sub>2</sub>	B <sub>0</sub>	B <sub>1</sub>	B <sub>2</sub>	B <sub>3</sub>	F <sub>0</sub>	F <sub>1</sub>	F <sub>2</sub>
P	Parking	○									
R	Reverse	○		○				○	○		
N	Neutral	○									
D	1 st	○	○						○		○
	2nd	○	○				○		○	○	
	3rd	○	○	○			○		○		
	O/D		○	○	○		○				
2	1 st	○	○						○		○
	2nd	○	○			○	○		○	○	
	3rd	○	○	○			○		○		
L	1 st	○	○					○	○		○
	* 2nd	○	○			○	○		○	○	

\* Down-shift only in the L position and 2nd gear—no up-shift.

# FUNCTION OF COMPONENTS

NOMENCLATURE	OPERATION
O/D Direct Clutch (C <sub>0</sub> )	Connects overdrive sun gear and overdrive carrier
O/D Brake (B <sub>0</sub> )	Prevents overdrive sun gear from turning either clockwise or counterclockwise
O/D One-Way Clutch (F <sub>0</sub> )	When transmission is being driven by engine, connects overdrive sun gear and overdrive carrier
Forward Clutch (C <sub>1</sub> )	Connects input shaft and front planetary ring gear
Direct Clutch (C <sub>2</sub> )	Connects input shaft and front & rear planetary sun gear
2nd Coast Brake (B <sub>1</sub> )	Prevents front & rear planetary sun gear from turning either clockwise or counterclockwise
2nd Brake (B <sub>2</sub> )	Prevents outer race of F, from turning either clockwise or counterclockwise, thus preventing front & rear planetary sun gear from turning counterclockwise
1 st & Reverse Brake (B <sub>3</sub> )	Prevents rear planetary carrier from turning either clockwise or counterclockwise
No. 1 One-Way Clutch (F <sub>1</sub> )	When B <sub>2</sub> is operating, prevents front & rear planetary sun gear from turning counterclockwise
No.2 One-Way Clutch (F <sub>2</sub> )	Prevents rear planetary carrier from turning counterclockwise

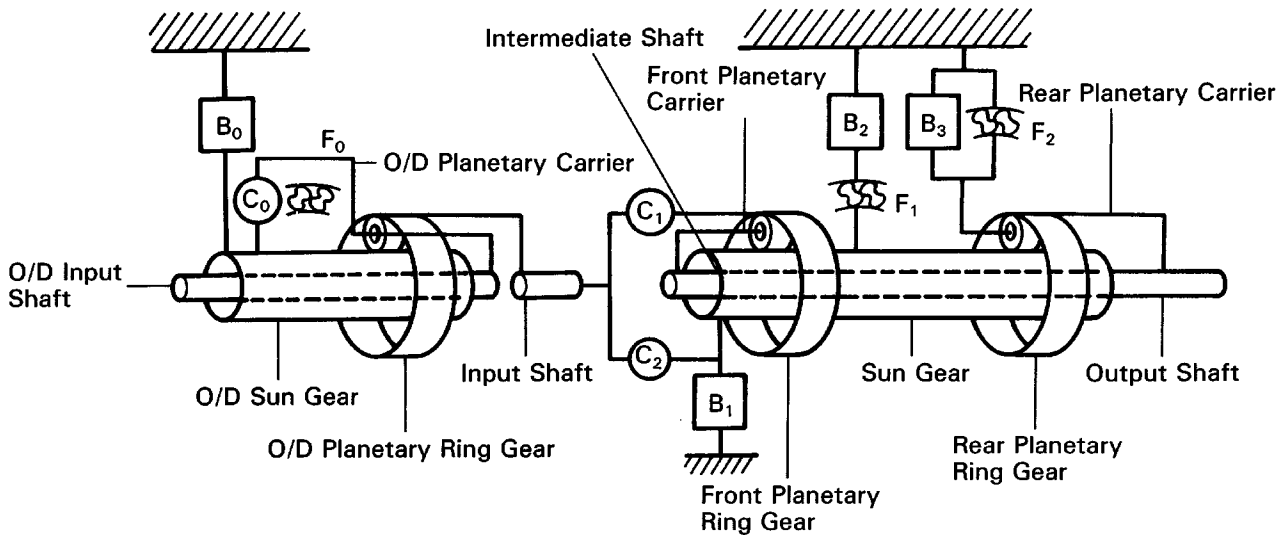

002957

# FUNCTION OF COMPONENTS (Cont'd)

The conditions of operation for each gear position are shown in the following illustrations:

**D or 2 Position 1st Gear**

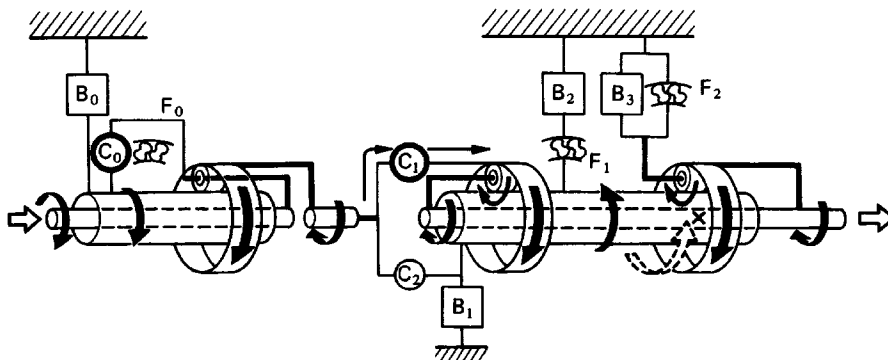

AT6675

**D Position 2nd Gear**

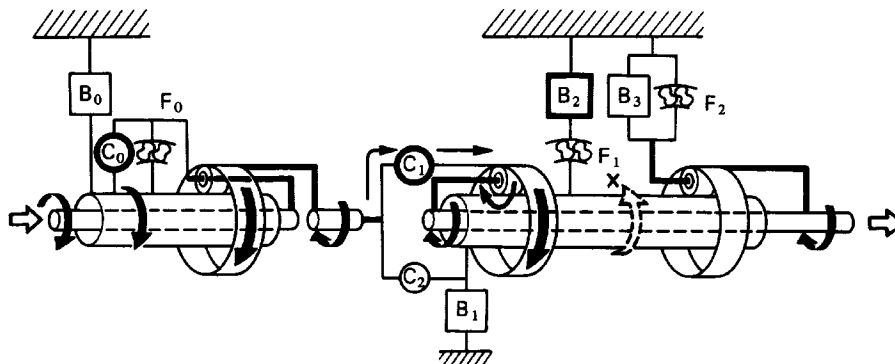

AT6676

**D or 2 Position 3rd Gear**

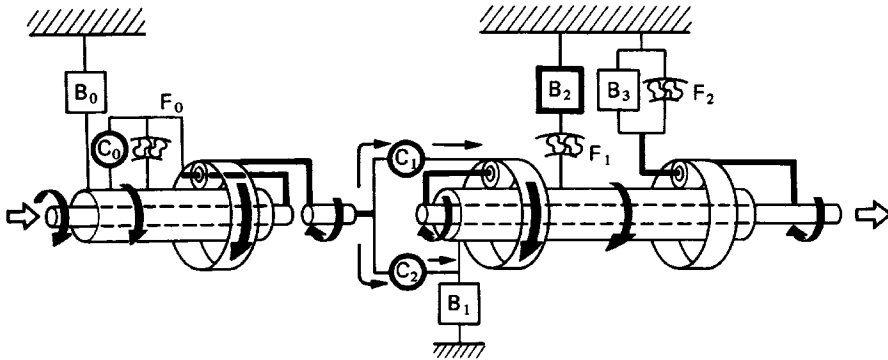

AT6677

**D Position O/D**

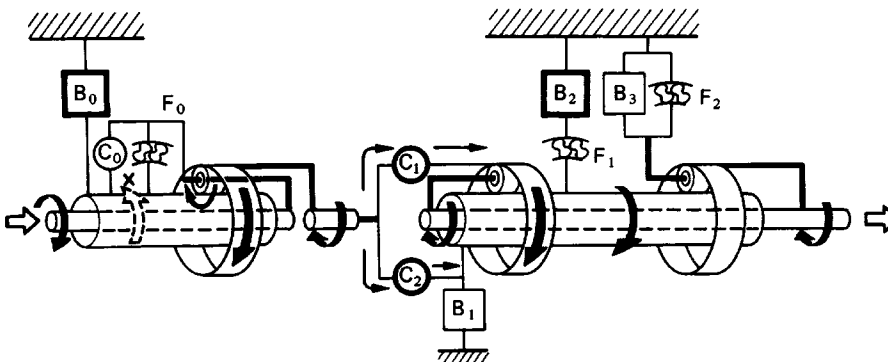

AT6678

# FUNCTION OF COMPONENTS (Cont'd)

**2 or L Position 2nd Gear**

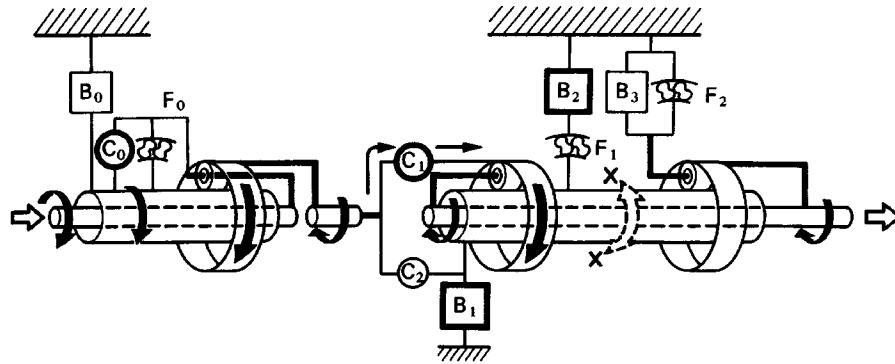

AT6679

**L Position 1st Gear**

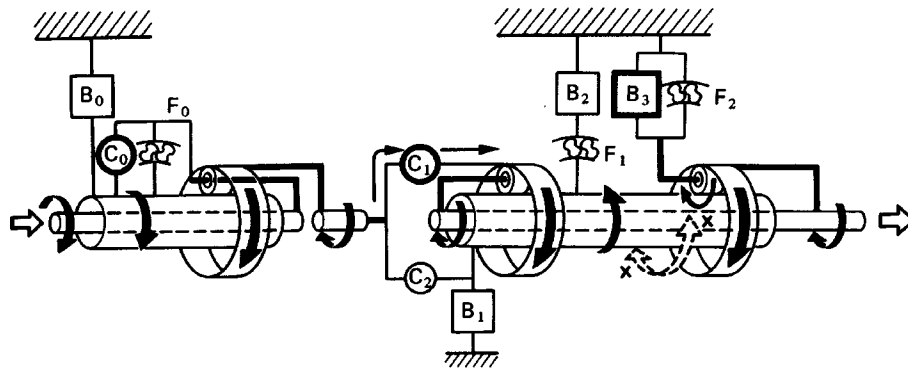

AT6680

**R Position Reverse Gear**

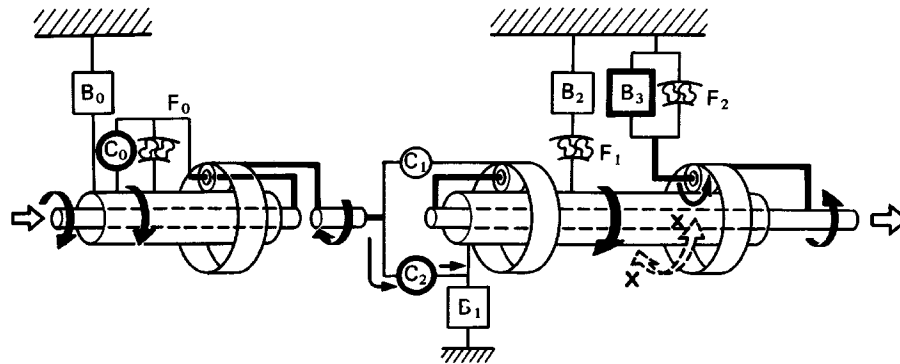

AT6681

## HYDRAULIC CONTROL SYSTEM

The hydraulic control system is composed of the oil pump, the valve body, the solenoid valves, and the clutches and brakes, as well as the fluid passages which connect all of these components. Based on the hydraulic pressure created by the oil pump, the hydraulic control system governs the hydraulic pressure acting on the torque converter clutch, clutches and brakes in accordance with the vehicle driving conditions.

There are three solenoid valves on the valve body. These solenoid valves are turned on and off by signals from the ECM to operate the shift valves. These shift valves then switch the fluid passages so that fluid goes to the torque converter clutch and planetary gear units.

(Except for the solenoid valves, the hydraulic control system of the electronic controlled transmission is basically the same as that of the fully hydraulic controlled automatic transmission.)

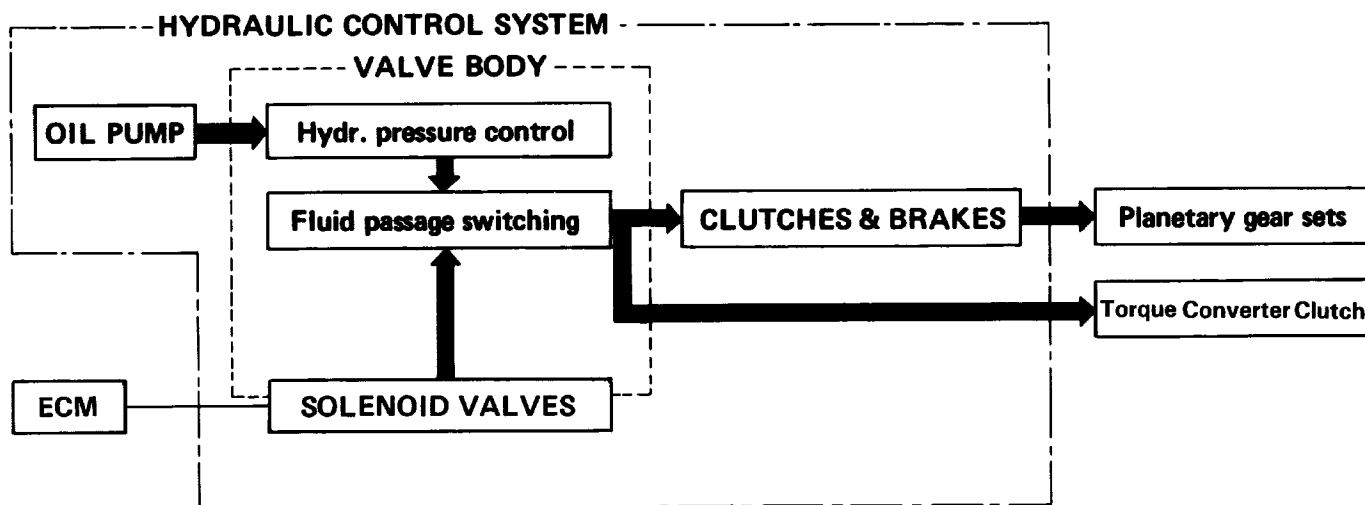

- **LINE PRESSURE**

Line pressure is the most basic and important pressure used in the automatic transmission, because it is used to operate all of the clutches and brakes in the transmission.

If the primary regulator valve does not operate correctly, line pressure will be either too high or too low. Line pressure that is too high will lead to shifting shock and consequent engine power loss due to the greater effort required of the oil pump; line pressure that is too low will cause slippage of clutches and brakes, which will, in extreme cases, prevent the vehicle from moving. Therefore, if either of these problems are noted, the line pressure should be measured to see if it is within standard.

- **THROTTLE PRESSURE**

Throttle pressure is always kept in accordance with the opening angle of the engine throttle valve. This throttle pressure acts on the primary regulator valve and, accordingly, line pressure is regulated in response to the throttle valve opening.

In the fully hydraulic controlled automatic transmission, throttle pressure is used for regulating line

- Pressure and as signal pressure for up-shift and down-shift of the transmission. In the electronic
- controlled transmission, however, throttle pressure is used only for regulating line pressure. Consequently, improper adjustment of the transmission throttle cable may result in a line pressure that is too high or too low. This, in turn, will lead to shifting shock or clutch and brake slippage.

## ELECTRONIC CONTROL SYSTEM

The electronic control system, which controls the shift points and the operation of the lock-up clutch, is composed of the following three parts:

### 1. Sensors

These sensors sense the vehicle speed, throttle opening and other conditions and send these data to the ECM in the form of electrical signals.

### 2. ECM

The ECM determines the shift and lock-up timing based upon the signals from sensors, and controls the solenoid valves of the hydraulic control unit accordingly.

### 3. Actuators

These are three solenoid valves that control hydraulic pressure acting on the hydraulic valves to control shifting and lock-up timing.

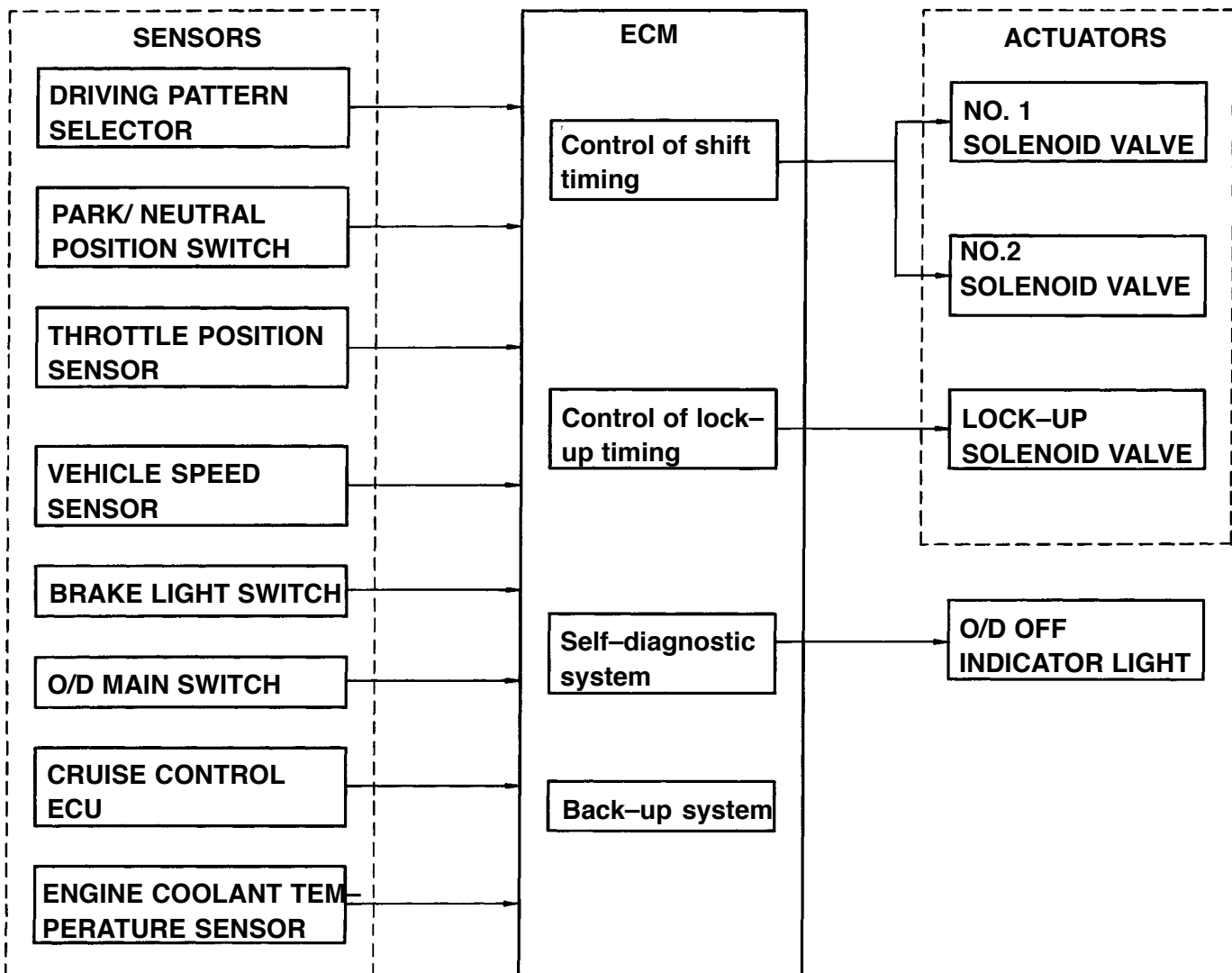

## FUNCTION OF ECM

### • Control of Shift Timing

The ECM has programmed into its memory the optimum shift pattern for each shift lever position (D, 2, L position) and driving mode (Normal or Power).

Based on the appropriate shift pattern, the ECM turns No. 1 and No.2 solenoid valves on or off in accordance with the vehicle speed signal from the vehicle speed sensor and the throttle opening signal from the throttle position sensor. In this manner, the ECM operates each shift valve, opening or closing the fluid passages to the clutches and brakes to permit up-shift or down-shift of the transmission.

HINT: The electronic control system provides shift timing and lock-up control only while the vehicle is traveling forward. In REVERSE, PARK, and NEUTRAL, the transmission is mechanically, not electronically controlled.

### • Control of Overdrive

Driving in overdrive is possible if the O/D main switch is on and the shift lever is in the D position. However, when the vehicle is being driven using the cruise control system (CCS), if the actual vehicle speed drops to about 4 km/h (2 mph) below the set speed while the vehicle is running in overdrive, the CCS ECU sends a signal to the ECM to release the overdrive and prevent the transmission from shifting back into overdrive until the actual vehicle speed reaches the speed set in the CCS memory.

On this model, if the engine coolant temperature falls below 70°C (158°F), preventing the transmission from up-shifting into overdrive.

### • Control of Lock-Up System

The ECM has programmed in its memory a lock-up clutch operation pattern for each driving mode (Normal or Power). Based on this lock-up pattern, the ECM turns lock-up solenoid valve on or off in accordance with the vehicle speed signals received from the vehicle speed sensor and the throttle opening signals from the throttle position sensor.

Depending on whether lock-up solenoid valve is on or off, the lock-up relay valve performs changeover of the fluid passages for the converter pressure acting on the torque converter clutch to engage or disengage the lock-up clutch.

(Mandatory Cancellation of Lock-Up System)

If any of the following conditions exist, the ECM turns off lock-up solenoid valve to disengage the lock-up clutch.

- 1) The brake light switch comes on (during braking).
- 2) The IDL points of the throttle position sensor close (throttle valve fully closed).
- 3) The engine coolant temperature falls below 70°C (158°F).

The purpose of 1) and 2) above is to prevent the engine from stalling if the rear wheels lock up. The purpose of 3) is to cause the torque converter clutch to operate to obtain torque multiplication. The purpose of 4) is both to improve general driveability, and to speed up transmission warm-up.

Also, while the lock-up system is in operation, the ECM will temporarily turn it off during up-shift or down-shift in order to decrease shifting shock.

# TROUBLESHOOTING

## Basic Troubleshooting

Before troubleshooting an electronic controlled transmission, first determine whether the problem is electrical or mechanical. To do this, just refer to the basic troubleshooting flow-chart provided below. If the cause is already known, using the basic troubleshooting chart below along with the general troubleshooting chart on the following pages should speed the procedure.

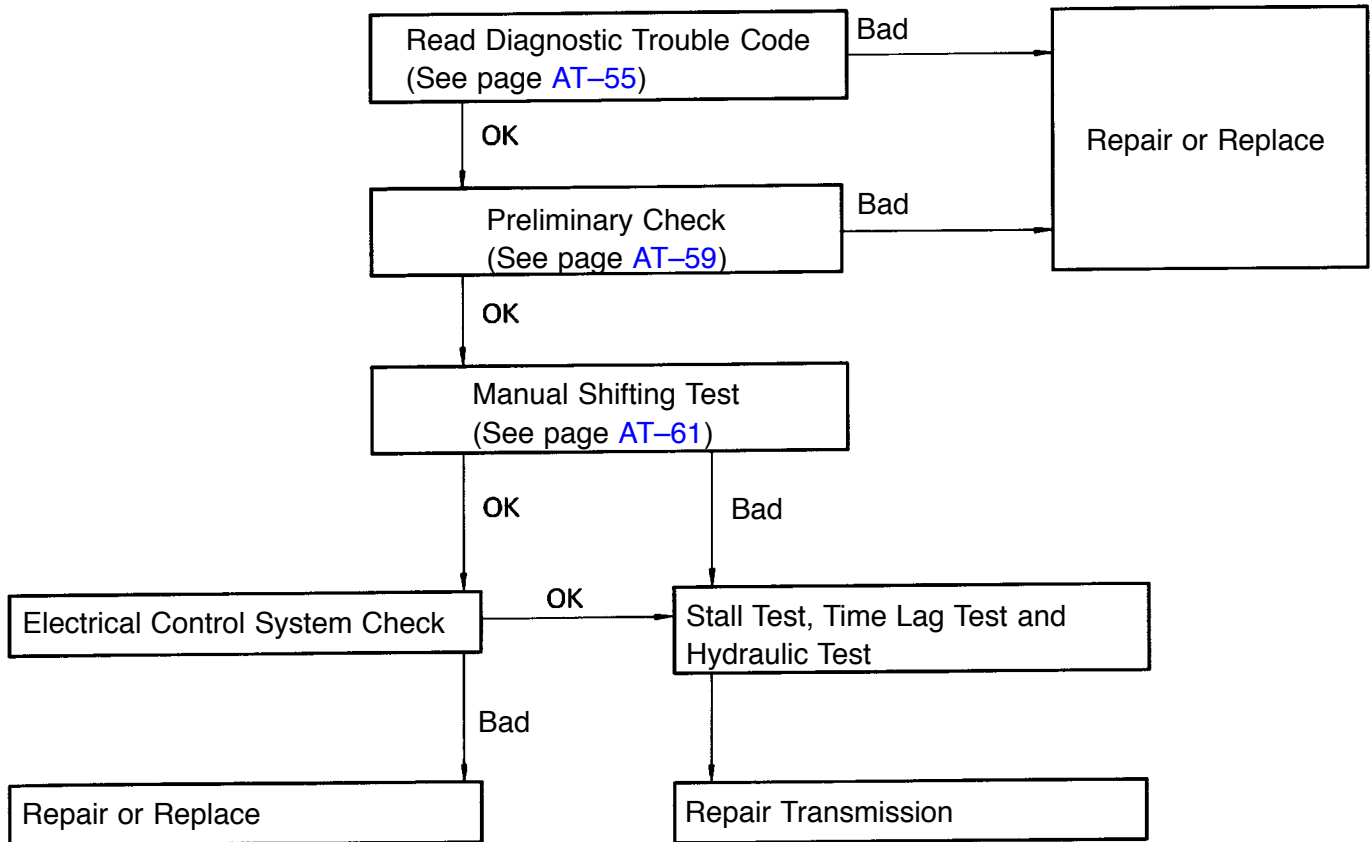



# General Troubleshooting

Problem	Possible cause	Remedy	Page
Fluid discolored or smells burnt	Fluid contaminated Torque converter clutch faulty Transmission faulty	Replace fluid Replace torque converter clutch Disassemble and inspect transmission	<a href="#">AT-59</a> <a href="#">AT-96</a>
Vehicle does not move in any forward position or reverse	Manual linkage out of adjustment Valve body or primary regulator faulty Parking lock pawl faulty Torque converter clutch faulty Converter drive plate broken Oil pump intake screen blocked Transmission faulty	Adjust linkage Inspect valve body Inspect parking lock pawl Replace torque converter clutch Replace drive plate Clean screen Disassemble and inspect transmission	<a href="#">AT-60</a> <a href="#">AT-87</a> <a href="#">AT-96</a> <a href="#">AT-96</a>
Shift lever position incorrect	Manual linkage out of adjustment Manual valve and lever faulty Transmission faulty	Adjust linkage Inspect valve body Disassemble and inspect transmission	<a href="#">AT-60</a>
Harsh engagement into any drive position	Throttle cable out of adjustment Valve body or primary regulator faulty Accumulator pistons faulty Transmission faulty	Adjust throttle cable Inspect valve body Inspect accumulator pistons Disassemble and inspect transmission	<a href="#">AT-60</a>
Delayed 1-2, 2-3 or 3-0/13 up-shift, or down-shift from O/D-3 or 3-2 and shifts back to O/D or 3	Electronic control faulty Valve body faulty Solenoid valve faulty	Inspect electronic control Inspect valve body Inspect solenoid valve	<a href="#">AT-63</a> <a href="#">AT-72</a>
Slips on 1-2, 2-3 or 3-0/D up-shift, or slips or shudders on acceleration	Manual linkage out of adjustment Throttle cable out of adjustment Valve body faulty Solenoid valve faulty Transmission faulty	Adjust linkage Adjust throttle cable Inspect valve body Inspect solenoid valve Disassemble and inspect transmission	<a href="#">AT-60</a> <a href="#">AT-60</a> <a href="#">AT-72</a>
Drag, binding or tie-up on 1-2, 2-3 or 3-O/D up-shift	Manual linkage out of adjustment Valve body faulty Transmission faulty	Adjust linkage Inspect valve body Disassemble and inspect transmission	<a href="#">AT-60</a>

Remark ,k : Refer to A340E Automatic Transmission Repair Manual. (Pub. No. RM271U)

## General Troubleshooting (Cont'd)

Problem	Possible cause	Remedy	Page
No lock-up in 2nd, 3rd or 01D	Electronic control faulty Valve body faulty Solenoid valve faulty Transmission faulty	Inspect electronic control Inspect valve body Inspect solenoid valve Disassemble and inspect transmission	AT-63 AT-72
Harsh down-shift	Throttle cable out of adjustment Throttle cable and cam faulty Accumulator pistons faulty Valve body faulty Transmission faulty	Adjust throttle cable Inspect throttle cable and cam Inspect accumulator pistons Inspect valve body Disassemble and inspect transmission	AT-60 AT-60
No down-shift when coasting	Valve body faulty Solenoid valve faulty Electronic control faulty	Inspect valve body Inspect solenoid valve Inspect electronic control	AT-72 AT-63
Down-shift occurs too quickly or too late while coasting	Throttle cable faulty Valve body faulty Transmission faulty  Solenoid valve faulty Electronic control faulty	Inspect throttle cable Inspect valve body Disassemble and inspect transmission Inspect solenoid valve Inspect electronic control	AT-60  AT-72 AT-63
No O/D-3, 3-2 or 2-1 kick-down	Solenoid valve faulty Electronic control faulty Valve body faulty	Inspect solenoid valve Inspect electronic control Inspect valve body	AT-72 AT-63
No engine braking 2 or L position	Solenoid valve faulty Electronic control faulty Valve body faulty Transmission faulty	Inspect solenoid valve Inspect electronic control Inspect valve body Disassemble and inspect transmission	AT-72 AT-63
Vehicle does not hold in P	Manual linkage out of adjustment Parking lock pawl cam and spring faulty	Adjust linkage Inspect cam and spring	AT-60 AT-87

Remark \*: Refer to A340E Automatic Transmission Repair Manual. (Pub. No. RM271U)

# Diagnosis System

## DESCRIPTION

1. A self-diagnosis function is built into the electrical control system. Warning is indicated by the overdrive OFF indicator light.

HINT: Warning and diagnostic trouble codes can be read only when the overdrive switch is ON. If OFF, the overdrive OFF light is lit continuously and will not blink.

(a) If a malfunction occurs within the vehicle speed sensors (No. 1 or 2) or solenoids (No. 1 or 2), the overdrive OFF light will blink to warn the driver.

However, there will be no warning of a malfunction with lock-up solenoid.

(b) The diagnostic trouble code can be read by the number of blinks of the overdrive OFF indicator light when terminals TIE, and E I are connected. (See page AT-56)

(c) The throttle position sensor or brake signal are not indicated, but inspection can be made by checking the voltage at terminal TT of the data link connector 1.

(d) The signals to each gear can be checked by measuring the voltage at terminal TT of the data link connector 1 while driving.

2. The diagnostic trouble code is retained in memory by the ECM and due to back-up voltage, is not canceled out when the engine is turned off. Consequently, after repair, it is necessary to turn the ignition switch off and remove the MFI fuse (15A) or disconnect the ECM connector to cancel out the diagnostic trouble code. (See page AT-56)

HINT:

Low battery positive voltage will cause faulty operation of the diagnosis system. Therefore, always check the battery first.

Use a voltmeter and ohmmeter that have an impedance of at least 10 kΩ/V.

## CHECK "O/D OFF" INDICATOR LIGHT

1. Turn the ignition switch ON.
2. The "O/D OFF" light will come on when the O/D switch is placed at OFF.
3. When the O/D switch is set to ON, the "O/D OFF" light should go out.

If the "O/D OFF" light flashes when the O/D switch is set to ON, the electronic control system is faulty.

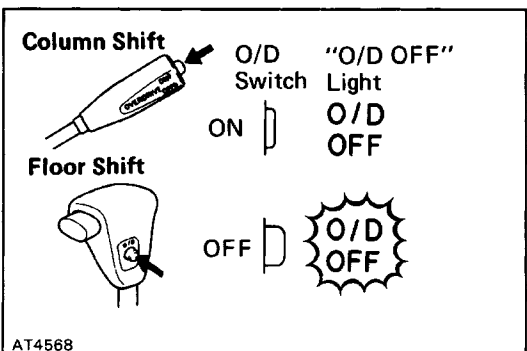
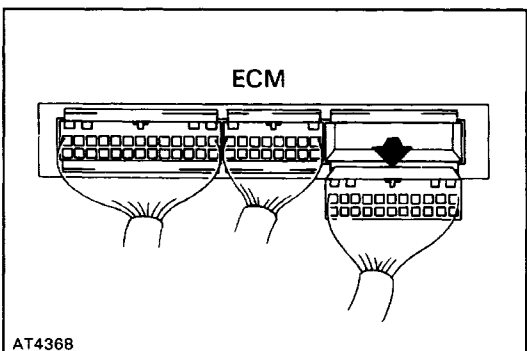
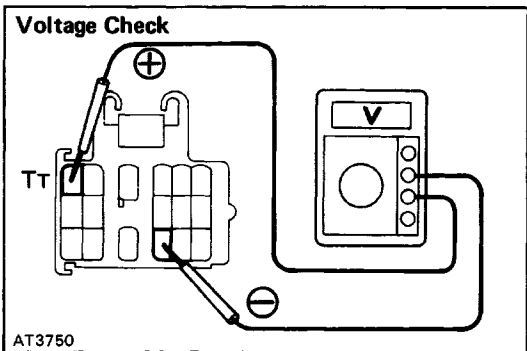
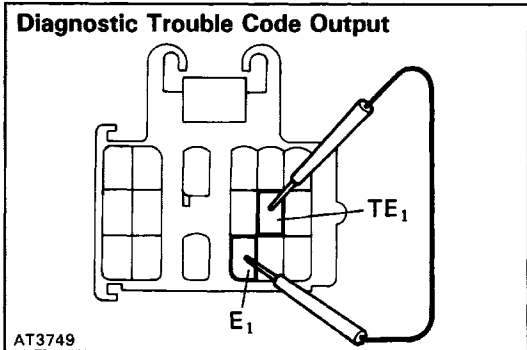
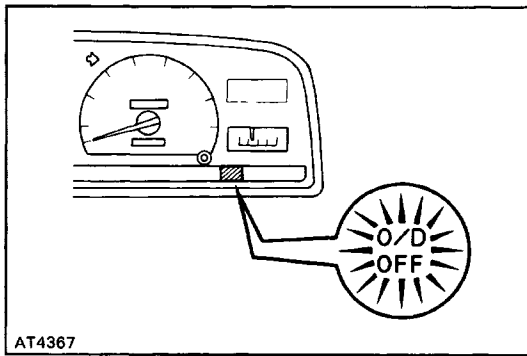

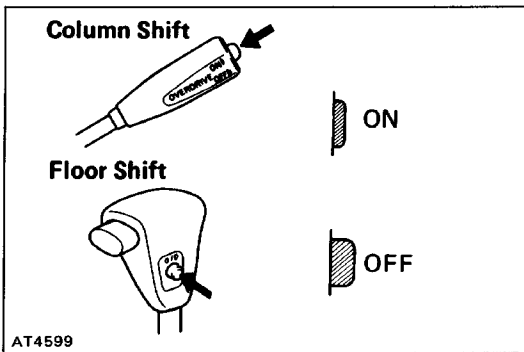

## READ DIAGNOSTIC TROUBLE CODE

### 1. TURN IGNITION SWITCH AND O/D SWITCH TO ON

Do not start the engine.

HINT: Warning and diagnostic trouble codes can be read only when the overdrive switch is ON. If OFF, the overdrive OFF light will light continuously and will not blink.

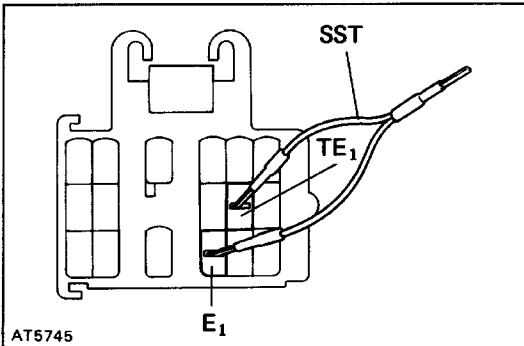

### 2. CONNECT TE, AND E, TERMINALS OF DATA LINK CONNECTOR 1

Using a SST, connect terminals TE, and E, of the data link connector 1.

SST 09843-18020

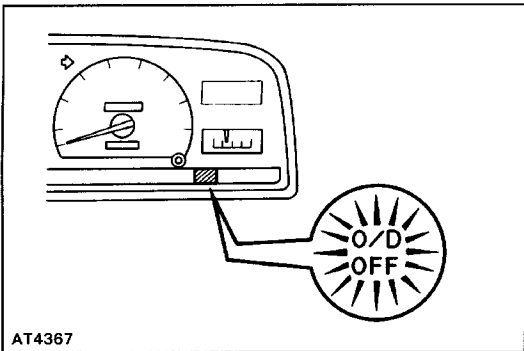

### 3. READ DIAGNOSTIC TROUBLE CODE

Read the diagnostic trouble code as indicated by the number of times the O/D OFF light flashes.

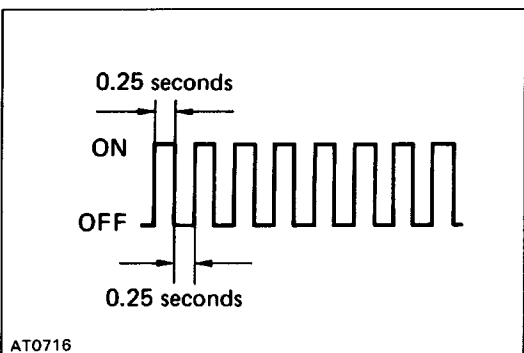

#### (Diagnostic Trouble Code Indication)

- If the system is operating normally, the light will flash 2 times per second.

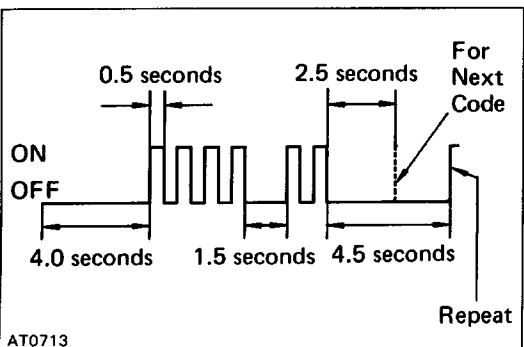





- In the event of a malfunction, the light will flash 1 time per second. The number of blinks will equal the first number and, after 1.5 seconds pause, the second number of the two digit diagnostic trouble code. If there are two or more codes, there will be a 2.5 seconds pause between each.

HINT: In the event of several trouble codes occurring simultaneously, indication will begin from the smaller value and continue to the larger.

### 4. REMOVE SST

## DIAGNOSTIC TROUBLE CODES

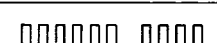
Code No.	Light Pattern	Diagnosis System
—		Normal
42		Defective No. 1 vehicle speed sensor (in ATM)— severed wire harness or short circuit
61		Defective No. 2 vehicle speed sensor (in ATM)— severed wire harness or short circuit
62		Severed No. 1 solenoid or short circuit— severed wire harness or short circuit
63		Severed No.2 solenoid or short circuit— severed wire harness or short circuit
64		Severed lock-up solenoid or short circuit— severed wire harness or short circuit

AT2020

HINT: If codes 62, 63 or 64 appear, there is an electrical malfunction in the solenoid.

Causes due to mechanical failure, such as a stuck valve, will not appear.

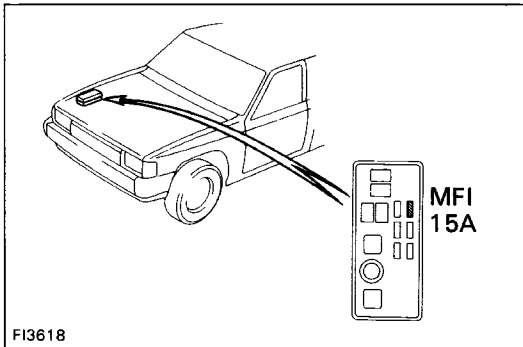

## CANCEL OUT DIAGNOSTIC TROUBLE CODE

- After repair of the trouble area, the diagnostic trouble code retained in memory by the ECM must be canceled by removing the MFI fuse (1 5A) for 10 seconds or more, depending on ambient temperature (the lower the temperature, the longer the fuse must be left out) with the ignition switch OFF.

HINT:

Cancellation can be also done by removing the battery negative (–) terminal, but in this case other memory systems will be also canceled out.

The diagnostic trouble code can be also canceled out by disconnecting the ECM connector.

If the diagnostic trouble code is not canceled out, it will be retained by the ECM and appear along with a new code in event of future trouble.

- After cancellation, perform a road test to confirm that a "normal code" is now read on the O/D OFF light.

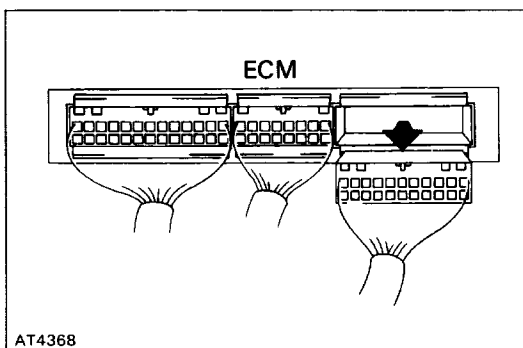

# TROUBLESHOOTING FLOW-CHART

**HINT:**

- If diagnostic trouble code Nos. 42, 61, 62 or 63 are output, the overdrive OFF indicator light will begin to blink immediately to warn the driver. However, an impact or shock may cause the blinking to stop; but the code will still be retained in the ECM memory until canceled out.
- There is no warning for diagnostic trouble code No. 64.
- In the event of a simultaneous malfunction of both No. 1 and No. 2 vehicle speed sensors, no diagnostic trouble code will appear and the fail-safe system will not function. However, when driving in the D position, the transmission will not up-shift from first gear, regardless of the vehicle speed.

**Diagnostic trouble code 42 (No. 1 vehicle speed sensor circuitry)**

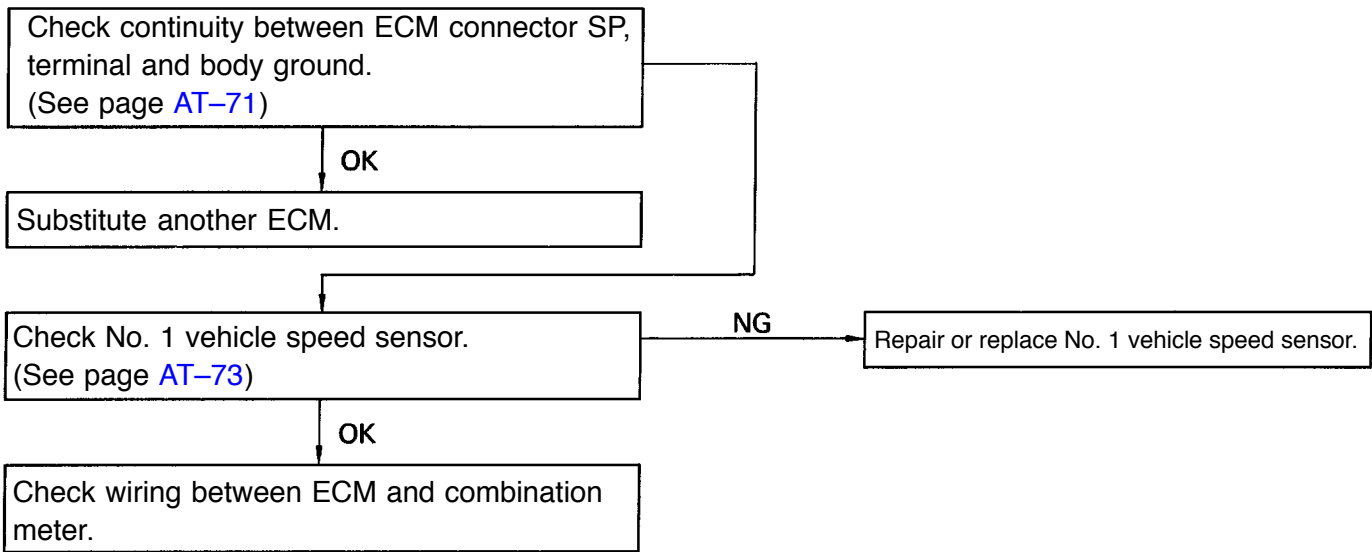

**Diagnostic trouble code 61 (No.2 vehicle speed sensor circuitry)**

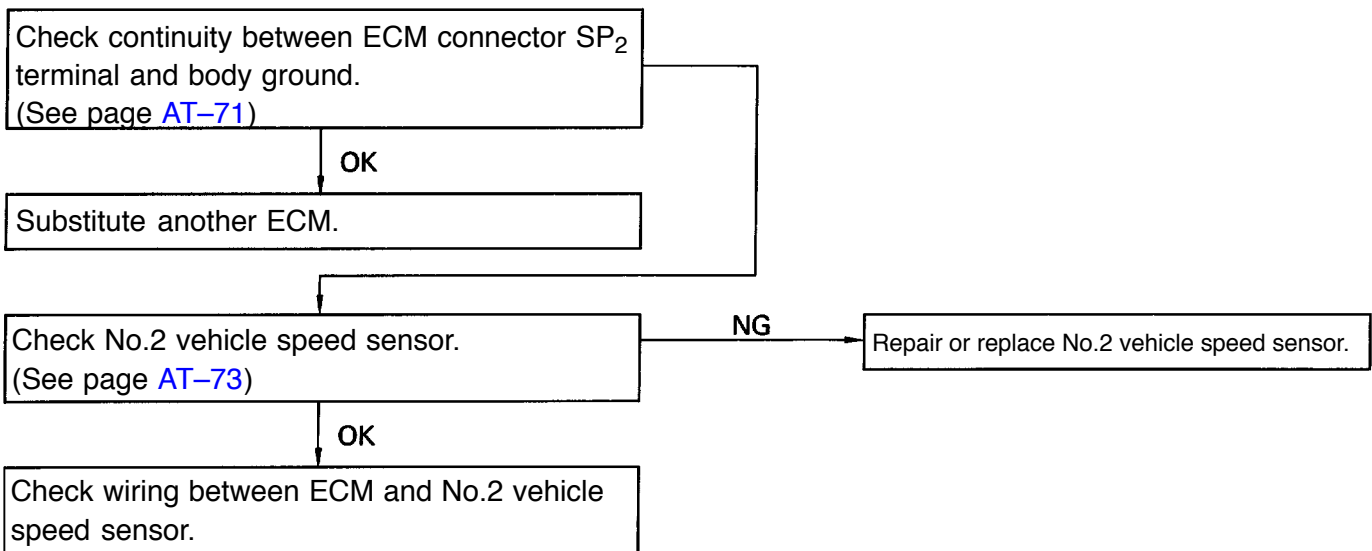

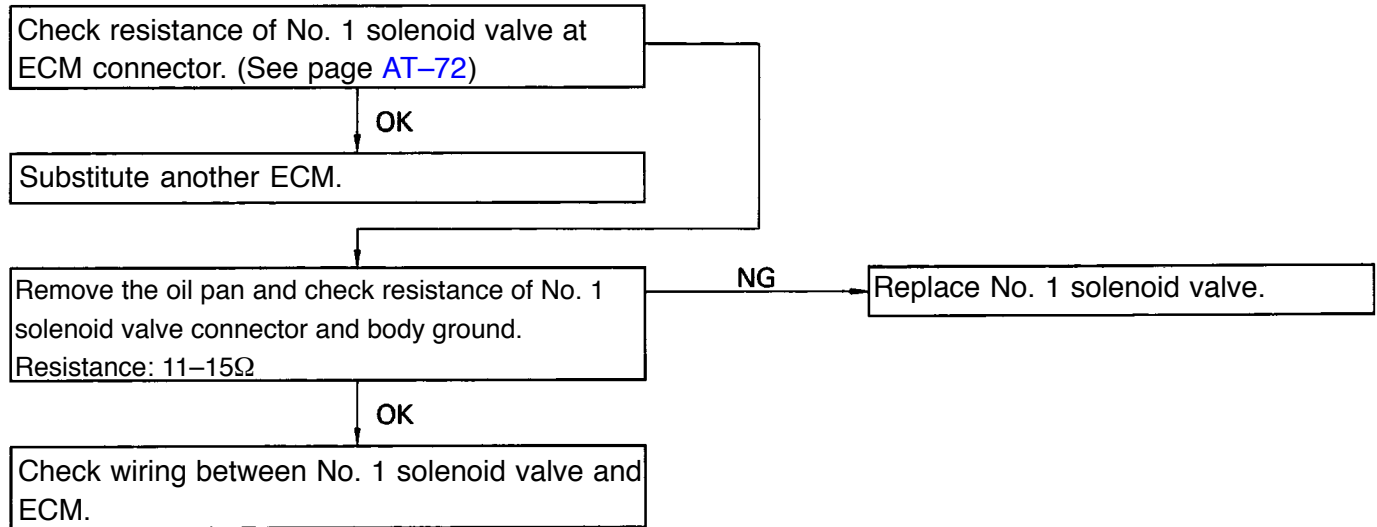
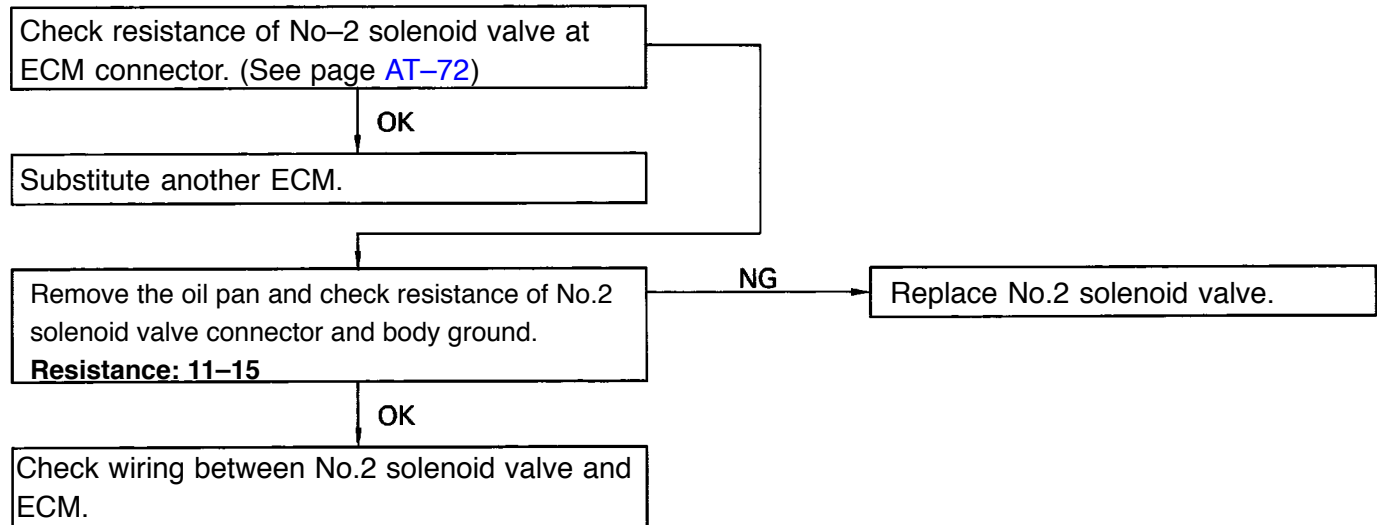
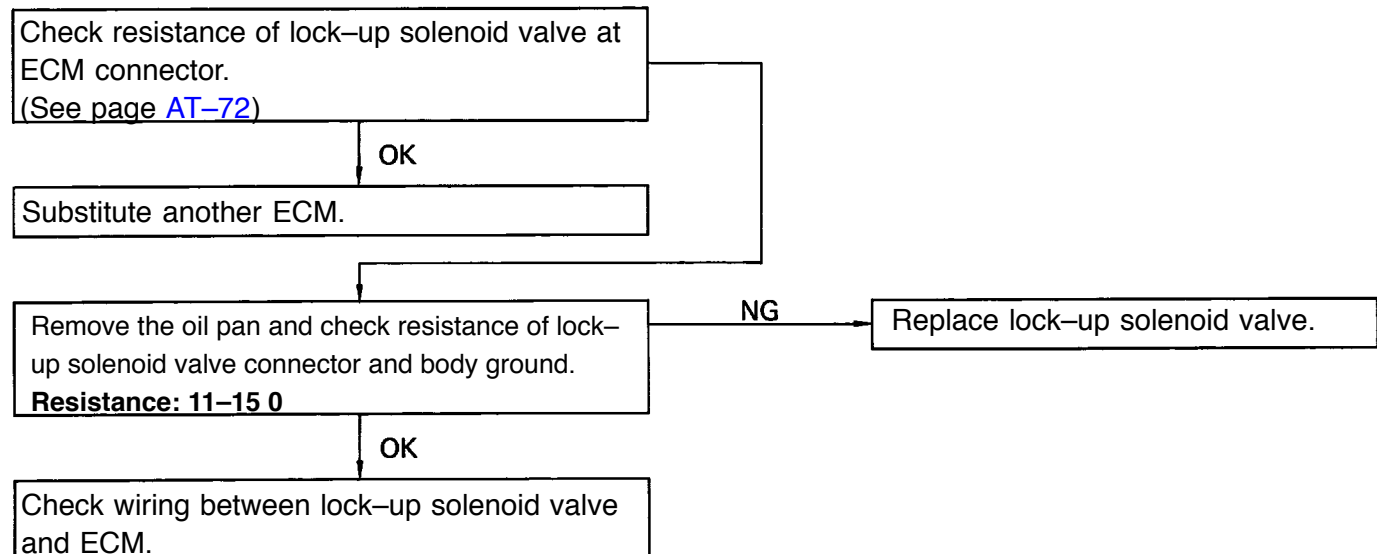
**Diagnostic trouble code 62 (No. 1 solenoid valve circuitry)****Diagnostic trouble code 63 (No.2 solenoid valve circuitry)****Diagnostic trouble code 64 (Lock-up solenoid valve circuitry)**

# Preliminary Check

## 1. CHECK FLUID LEVEL

HINT:

The vehicle must have been driven so that the engine and transmission are at normal operating temperature. (Fluid temperature: 70–80 °C or 158–176 °F)

Only use the COOL range on the dipstick as a rough reference when the fluid is replaced or the engine does not run.

- (a) Park the vehicle on a level surface, set the parking brake.
- (b) With the engine idling, shift the shift lever into all positions from P to L position and return to P position.

HINT: Depress brake pedal.

- (c) Pull out the transmission dipstick and wipe it clean.
- (d) Push it back fully into the tube.
- (e) Pull it out and check that the fluid level is in the HOT range.

If the level is at the low side, add fluid.

**Fluid type: ATF DEXRON® II**

**NOTICE: Do not overfill.**

## 2. CHECK FLUID CONDITION

If the fluid smells burnt or is black, replace it as following procedures.

- (a) Remove the drain plug and drain the fluid.
- (b) Reinstall the drain plug securely.
- (c) With the engine OFF, add new fluid through the oil filler tube.

**Fluid type ATF DEXRON® II**

**Capacity:**

**Total: 7.2 liters (7.6 US qts, 6.3 Imp qts)**

**Drain and refill: 1.6 liters (1.7 US qts, 1.4 Imp.qts)**

- (d) Start the engine and shift the shift lever into all positions from P to L position and then shift into P position.
- (e) With the engine idling, check the fluid level. Add fluid up to the COOL level on the dipstick.
- (f) Check the fluid level with the normal operating temperature (70–80 °C or 158–176 °F) and add as necessary.

**NOTICE: Do not overfill.**

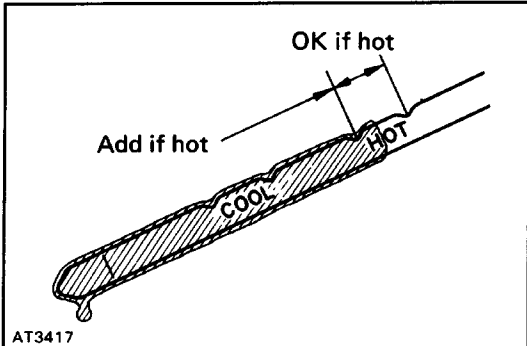

AT3417

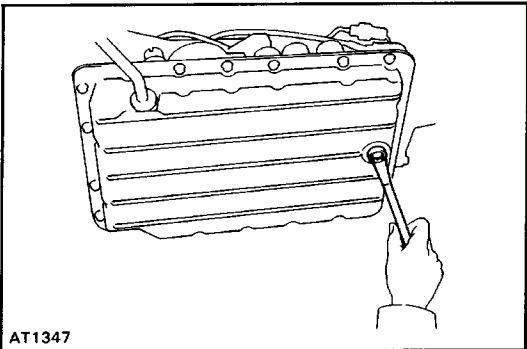

AT1347

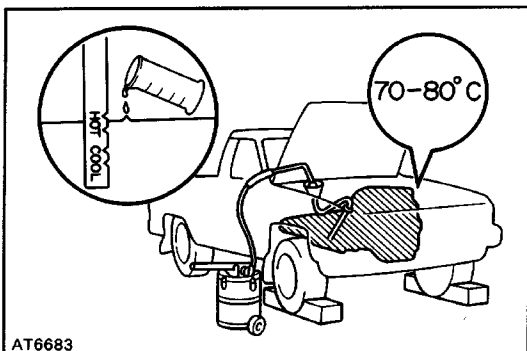

AT6683

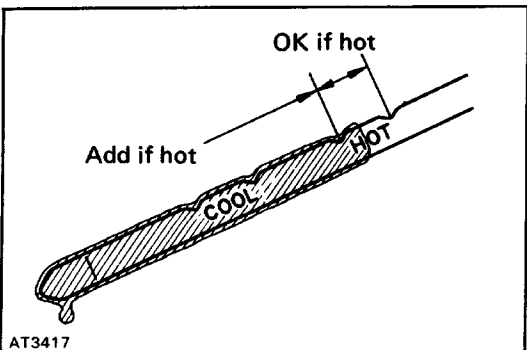

AT3417



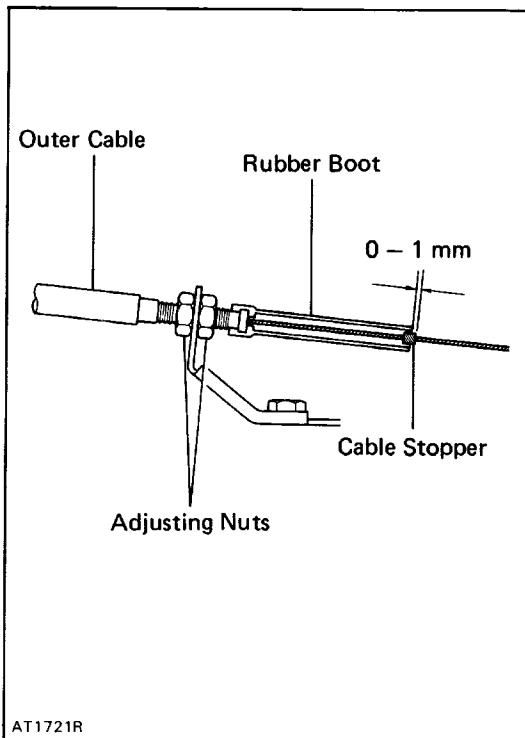

### 3. INSPECT THROTTLE CABLE

(a) Depress the accelerator pedal all the way and check that the throttle valve opens fully.

HINT: If the valve does not open fully, adjust the accelerator cable.

(b) Fully depress the accelerator pedal.

(c) Measure the distance between the end of the boot and stopper on the cable.

**Standard distance: 0-1 mm (0-0.04 in.)**

If the distance is not standard, adjust the cable by the adjusting nuts.

### 4. INSPECT SHIFT LEVER POSITION

When shifting the shift lever from the N position to other positions, check that the lever can be shifted smoothly and accurately to each position and that the position indicator correctly indicates the position.

If the indicator is not aligned with the correct position, carry out the following adjustment procedures.

#### (Column shift)

(a) Remove the nut on the cross shaft rod.

(b) Push the cross shaft rod fully downward.

(c) Return the cross shaft rod two notches to N position.

(d) Set the shift lever to N position.

(e) While holding the shift lever lightly toward the R position side, adjust the cross shaft rod nut.

(f) Tighten the cross shaft rod nut.

(g) Start the engine and make sure that the vehicle moves forward when shifting the lever from the N to D position and reverse when shifting it to the R position.

#### (Floor shift)

(a) Remove the nut on the cross shaft rod.

(b) Push the cross shaft rod fully downward.

(c) Return the cross shaft rod three notches to N position.

(d) Set the shift lever to N position.

(e) While holding the shift lever lightly toward the R position side, adjust the cross shaft rod nut.

(f) Tighten the cross shaft rod nut.

(g) Start the engine and make sure that the vehicle moves forward when shifting the lever from the N to D position and reverse when shifting it to the R position.

### 5. INSPECT PARK/NEUTRAL POSITION SWITCH

Check that the engine can be started with the shift lever only in the N or P position, but not in other positions.

If not as stated above, carry out the following adjustment procedures.

(a) Loosen the park/neutral position switch bolt and set the shift lever to the N position.

(b) Align the groove and neutral basic line.

(c) Hold in position and tighten the bolt.

**Torque: 13 N-m (130 kgf-cm, 9 in.·lbf)**

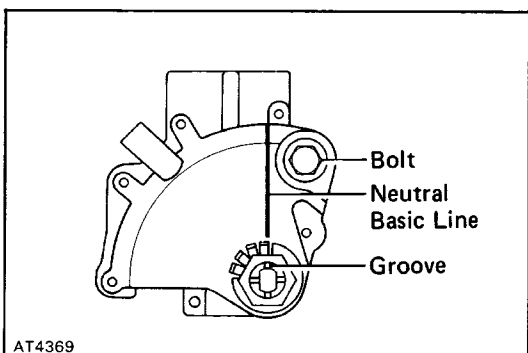
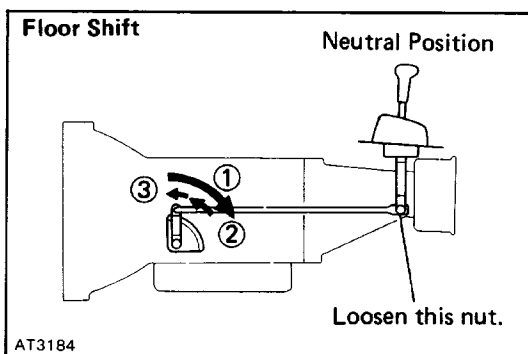
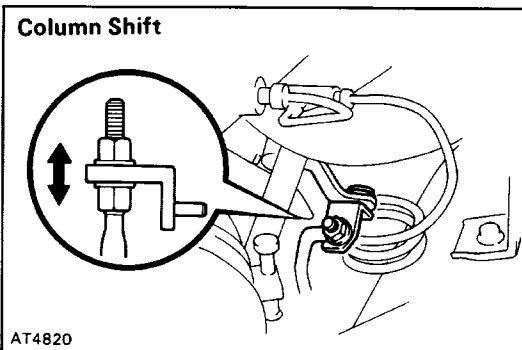

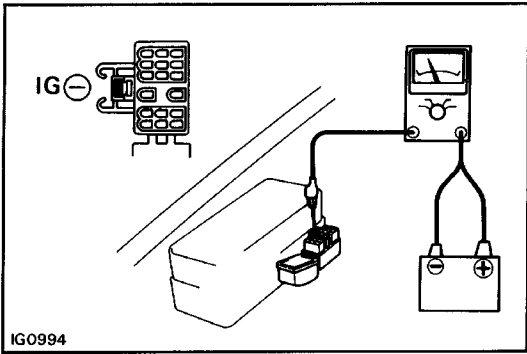

**6. INSPECT IDLE SPEED (IN POSITION)**

Connect a tachometer test probe to the data link connector 1 terminal IG ∞, inspect the idle speed.

**Idle speed: 800 RPM**

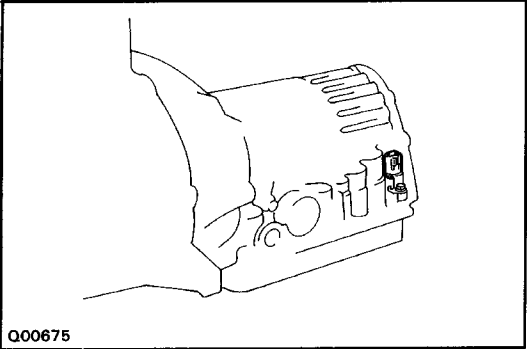

**Manual Shifting Test**

HINT: With this test, it can be determined whether the trouble lies within the electrical circuit or is a mechanical problem in the transmission.

**1. DISCONNECT SOLENOID WIRE**

**2. INSPECT MANUAL DRIVING OPERATION**

Check that the shift and gear position correspond with the table below.

Shift position	D position	2 position	L position	R position	P position
Gear position	O/D	3rd	<b>1st</b>	Reverse	Pawl Lock

HINT: If the L, 2 and D position gear positions are difficult to distinguish, perform the following road test.

- While driving, shift through the L, 2 and D positions. Check that the gear change corresponds to the shift position.

If any abnormality is found in the above test, the problem lies in transmission itself.

**3. CONNECT SOLENOID WIRE**

**4. CANCEL OUT DIAGNOSTIC TROUBLE CODE**

(See page [AT-56](#))

REFERENCE: Possible gear position in accordance with solenoid operating conditions.

Position	NORMAL			NO. 1 SOLENOID MALFUNCTIONING			NO.2 SOLENOID MALFUNCTIONING			BOTH SOLENOIDS MALFUNCTIONING		
	Solenoid Valve		Gear Position	Solenoid Valve		Gear Position	Solenoid Valve		Gear Position	Solenoid Valve		Gear Position
	No. 1	No. 2		No. 1	No. 2		No. 1	No. 2		No. 1	No. 2	
<b>D position</b>	ON	OFF	1 st	x	ON (OFF)	3rd (O/D)	ON	x	1 st	x	x	O/D
	ON	ON	2nd	x	ON	3rd	OFF (ON)	x	O/D (1st)	x	x	O/D
	OFF	ON	3rd	x	ON	3rd	OFF	x	O/D	x	x	O/D
	OFF	OFF	O/D	x	OFF	O/D	OFF	x	O/D	x	x	O/D
<b>2 position</b>	ON	OFF	1 st	x	ON (OFF)	3rd (O/D)	ON	x	1 st	x	x	3rd
	ON	ON	2nd	x	ON	3rd	OFF (ON)	x	3rd (1st)	x	x	3rd
	OFF	ON	3rd	x	ON	3rd	OFF	x	3rd	x	x	3rd
<b>L position</b>	ON	OFF	1 st	x	OFF	1st	ON	x	1 st	x	x	1st
	ON	ON	2nd	x	ON	2nd	ON	x	1 st	x	x	1 st

( ): No fail-safe function

x : Malfunctions

# Electronic Control System PRECAUTION

Do not open the cover or the case of the ECM and various computer unless absolutely necessary. (If the IC terminals are touched, the IC may be destroyed by static electricity.)

## ELECTRONIC CONTROL CIRCUIT

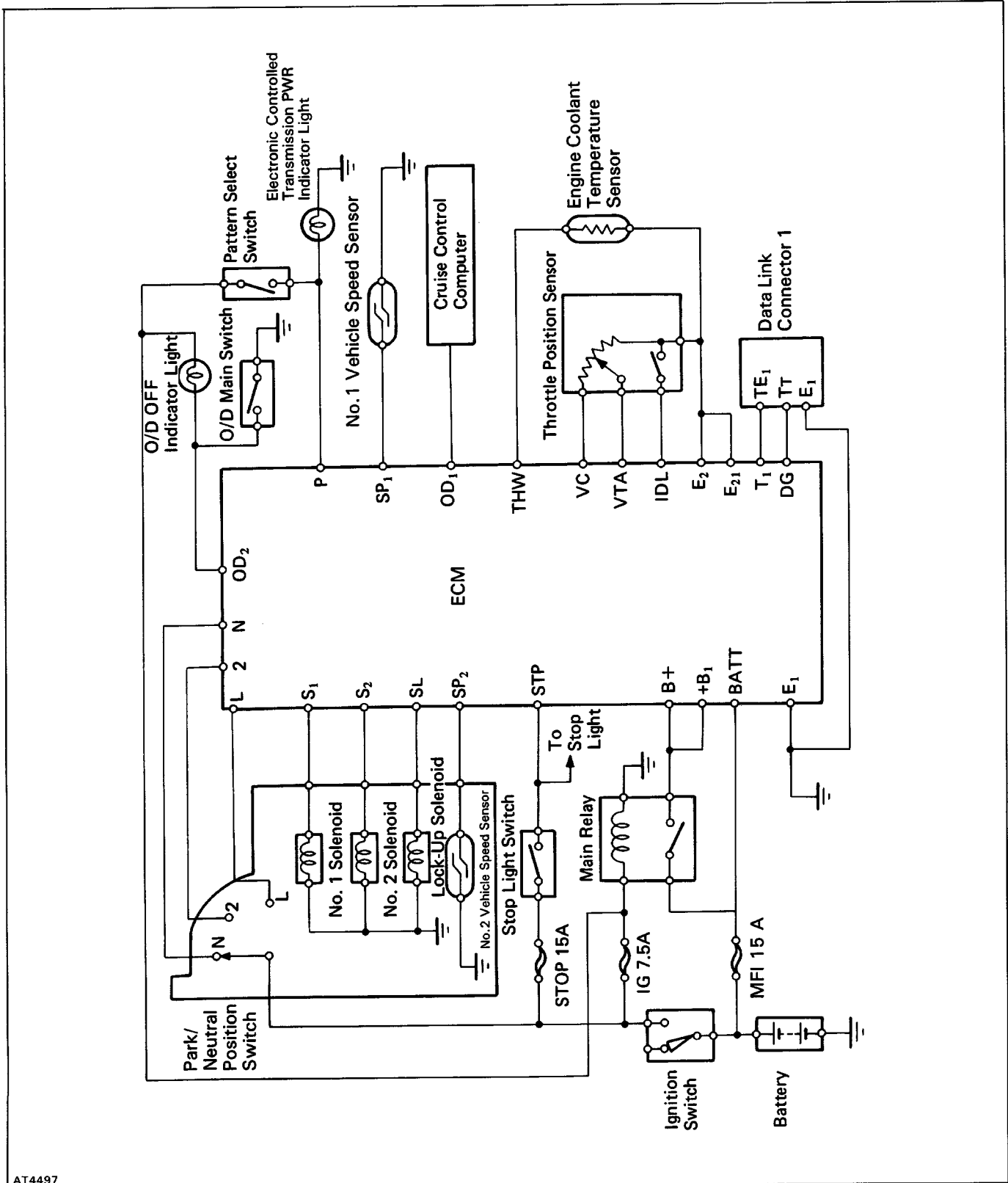

# ELECTRONIC CONTROL COMPONENTS

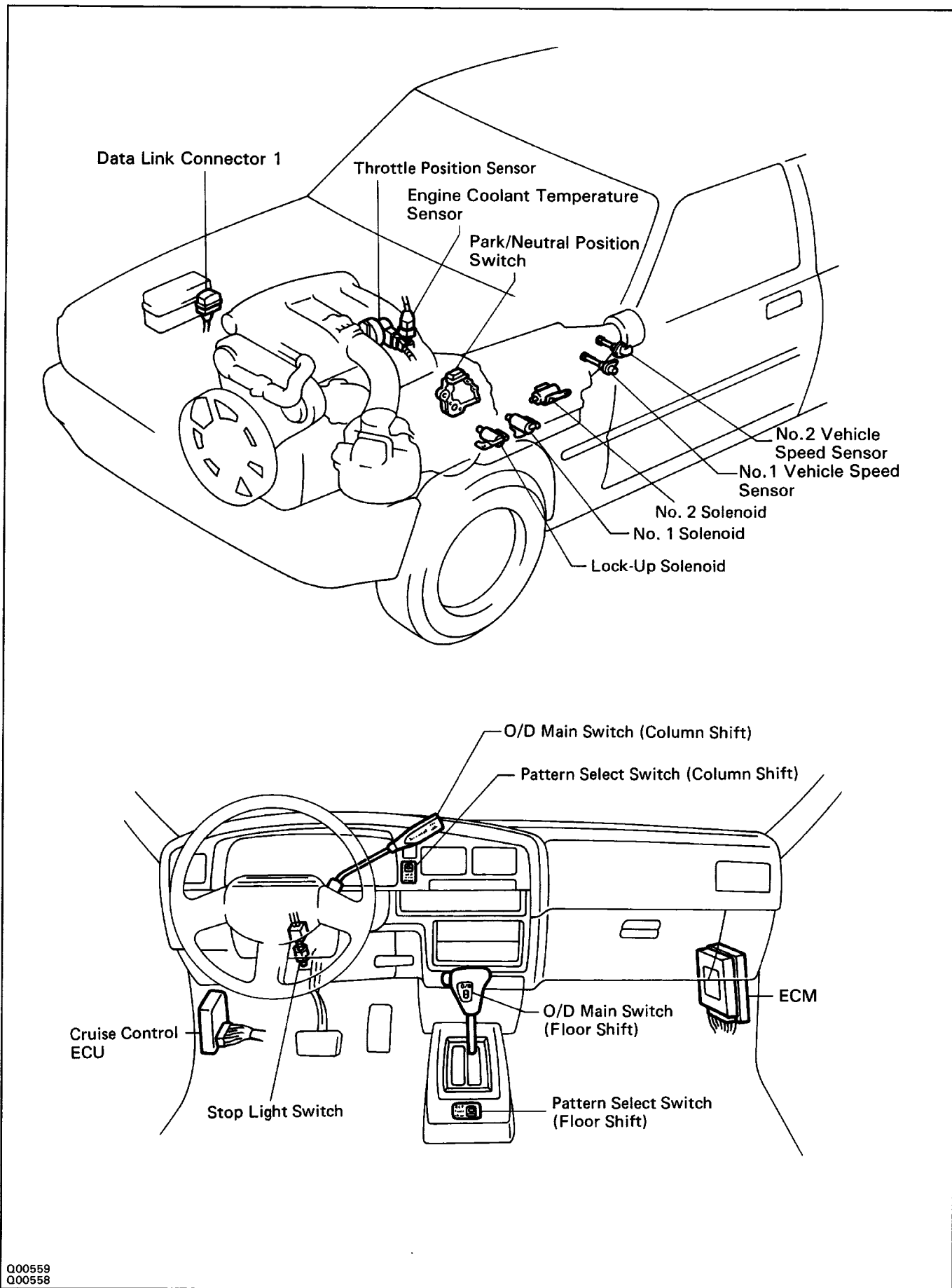

# TROUBLESHOOTING FLOW-CHART

## Trouble No. 1 No Shifting

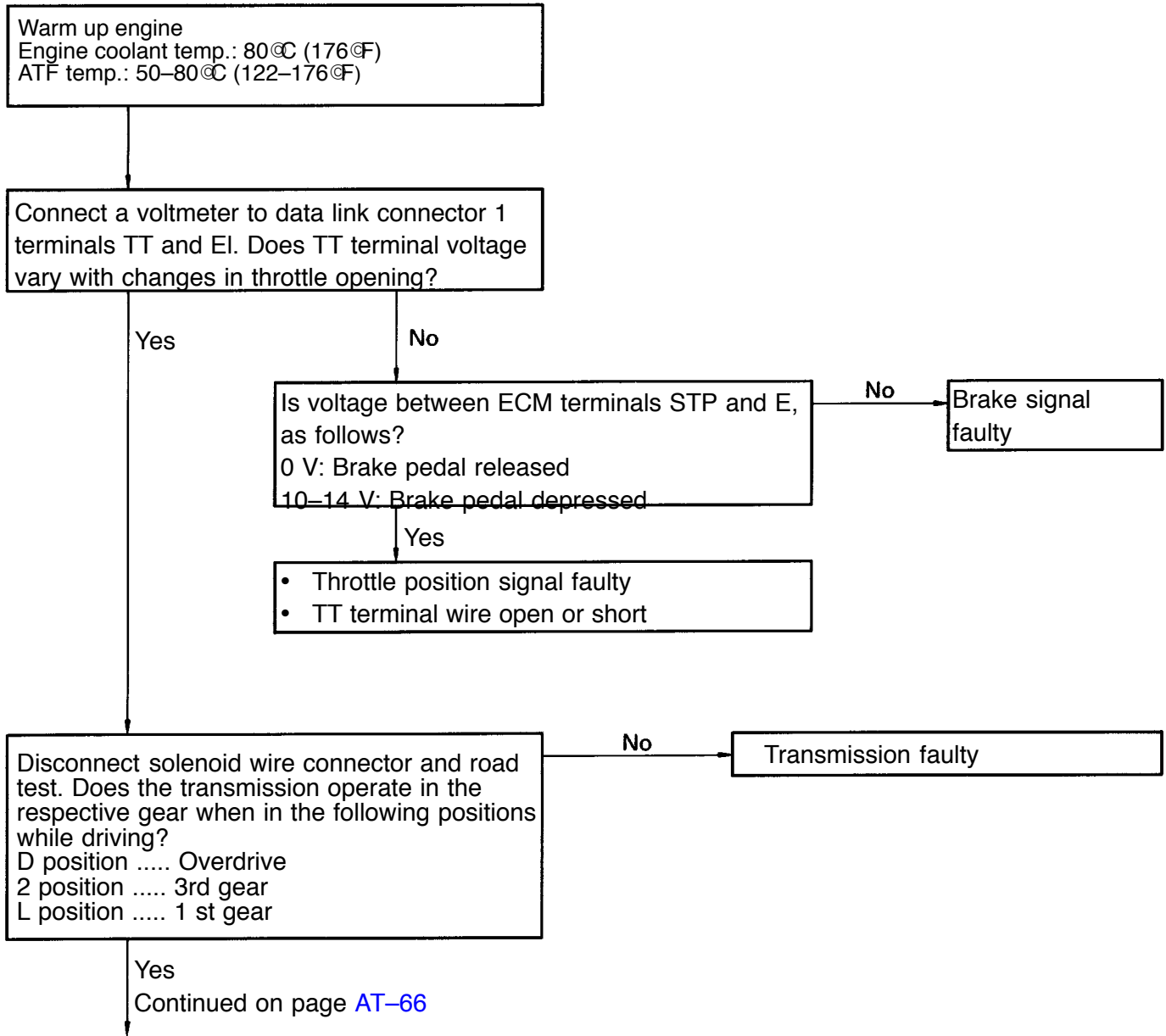

Continued from page [AT-65](#)

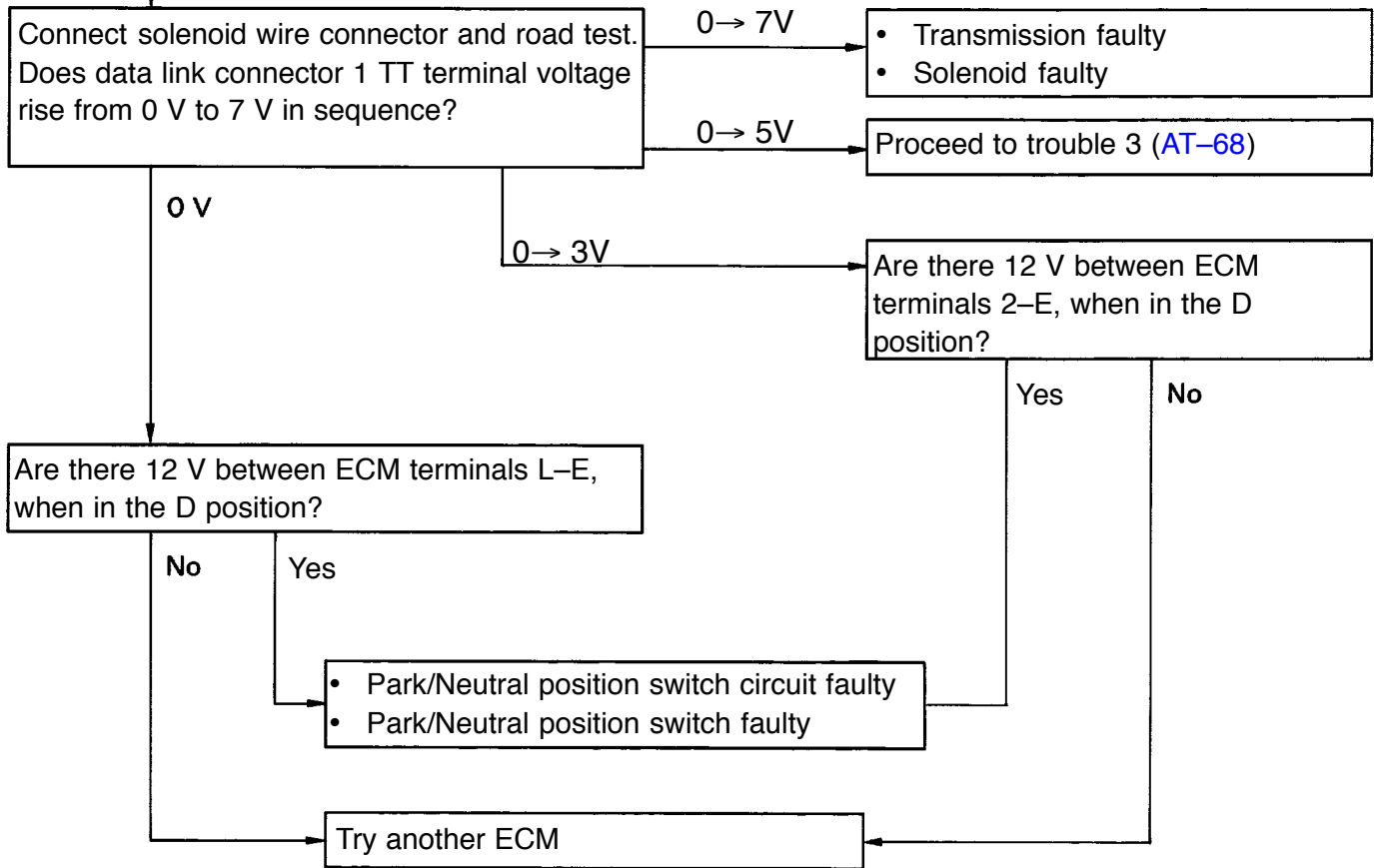

**Trouble No.2 Shift point too high or too low**

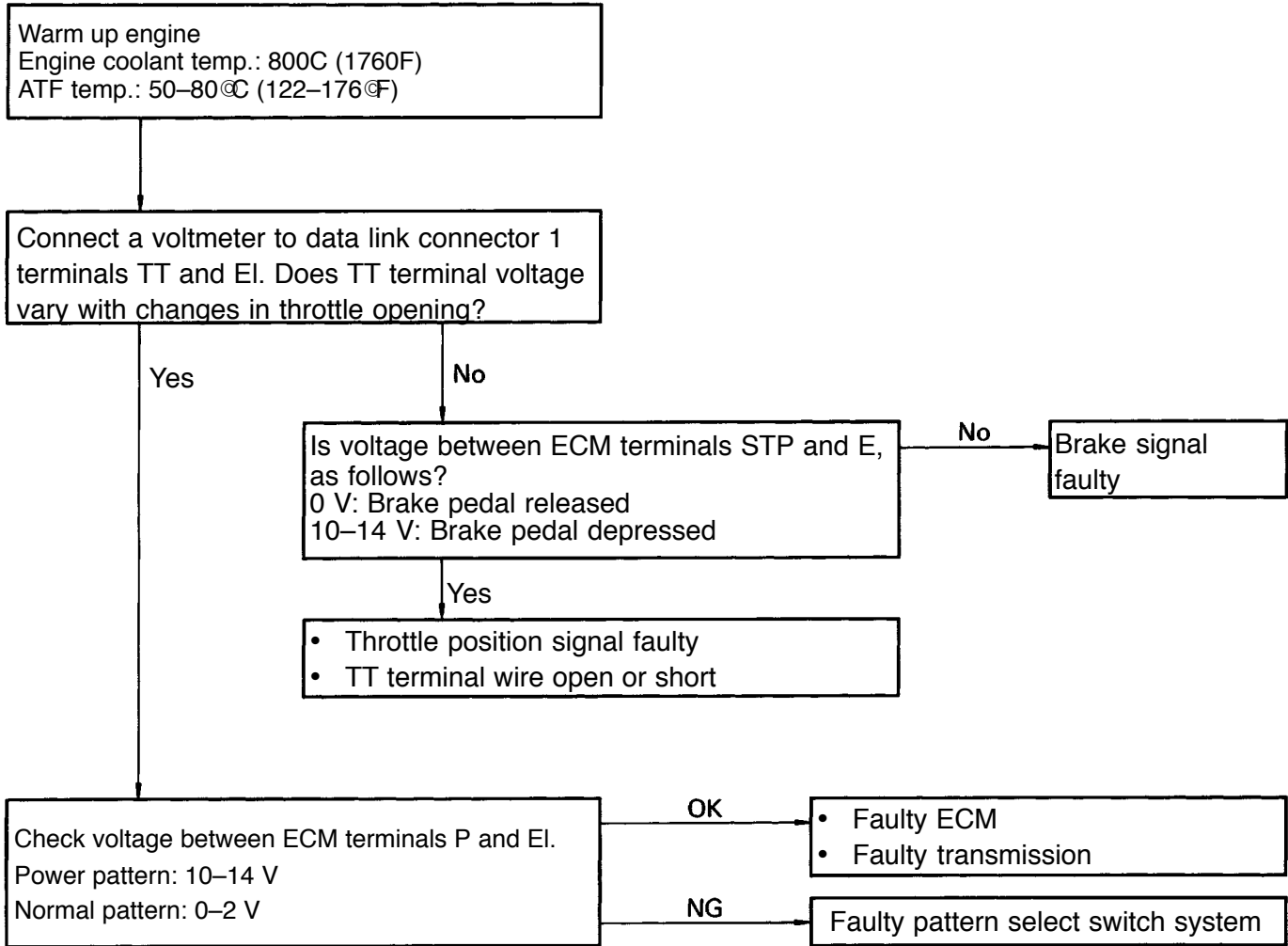



**Trouble No.3 No up-shift to overdrive (After warm-up)**

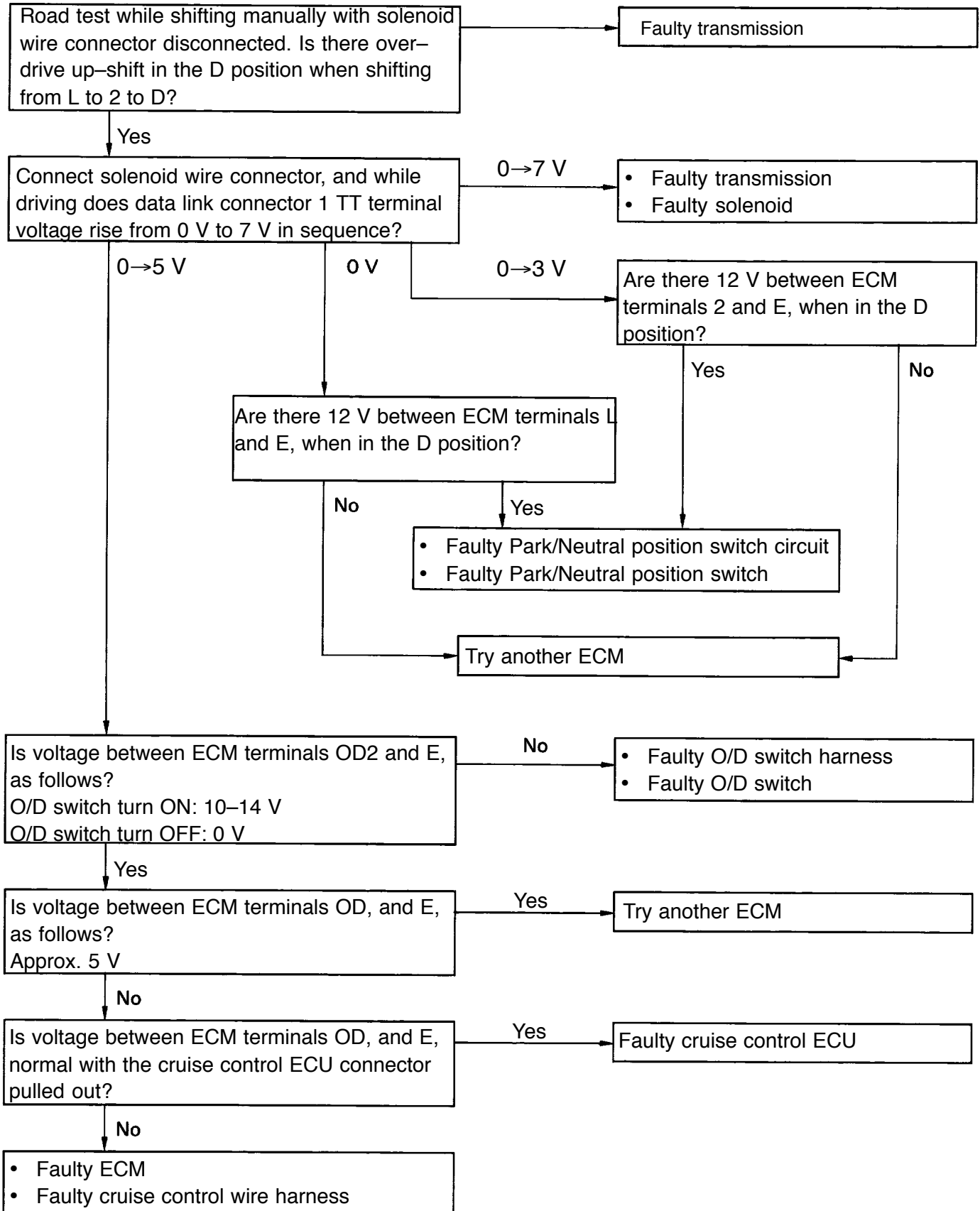

**Trouble No.4 No lock-up (After warm-up)**

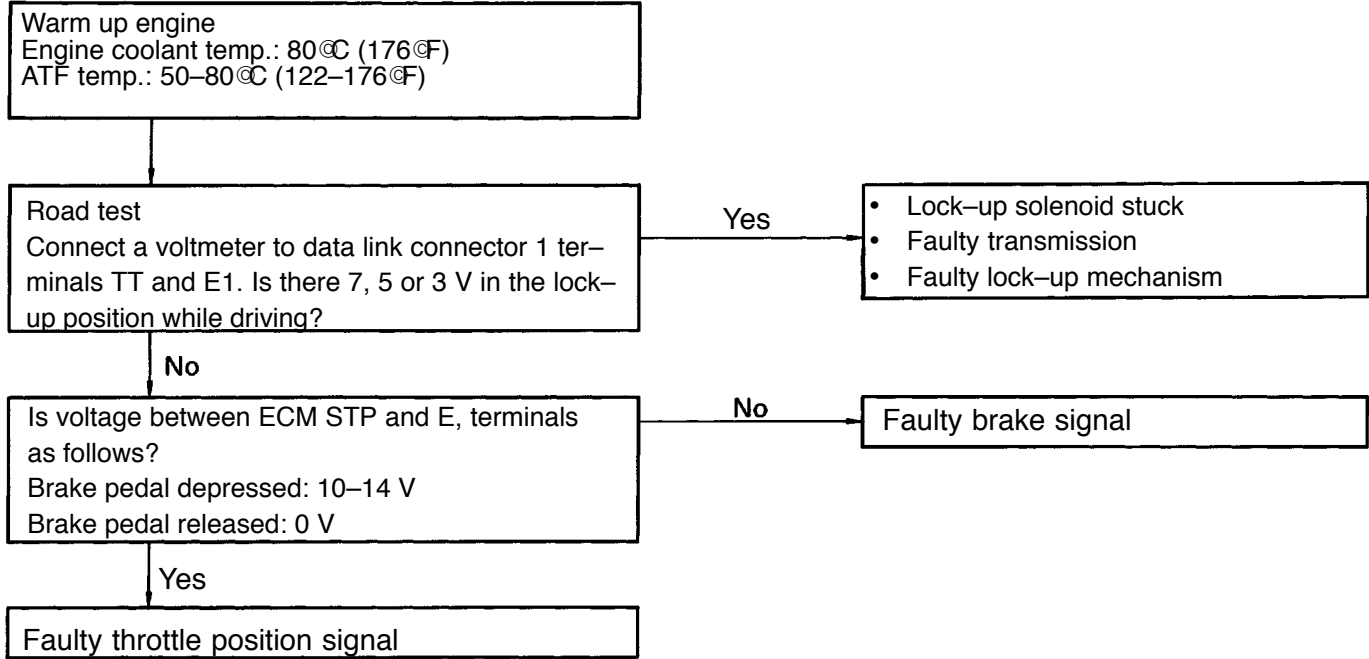

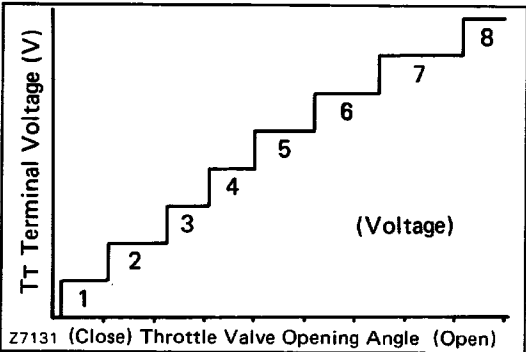
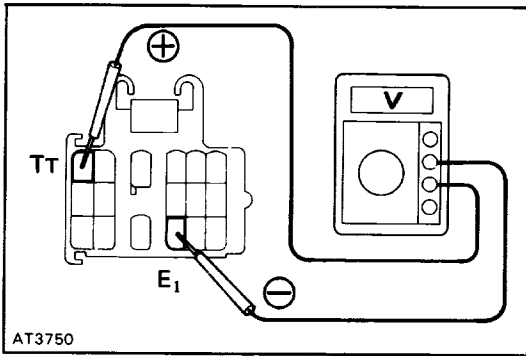

## INSPECTION OF TT TERMINAL VOLTAGE

### 1. INSPECT THROTTLE POSITION SENSOR SIGNAL

- (a) Turn the ignition switch to ON. Do not start the engine.
- (b) Connect a voltmeter to data link connector 1 terminals TT and E1.

(c) While slowly depressing the accelerator pedal, check that TT terminal voltage rises in sequence. If the voltage does not change in proportion to the throttle opening angle, there is a malfunction in the throttle position sensor or circuit.

### 2. INSPECT BRAKE SIGNAL

- (a) Depress the accelerator pedal until the TT terminal indicates 8V.
- (b) Depress the brake pedal and check the voltage reading from the TT terminal.
  - Brake pedal depressed ..... 0 v
  - Brake pedal released ..... 8 V

If not as indicated, there is a malfunction in either the stop light switch or circuit.

### 3. INSPECT EACH UP-SHIFT POSITION

- (a) Warm up the engine.
  - Engine coolant temperature: 80 °C (176 °F)**
- (b) Turn the O/D switch to "ON".
- (c) Place the pattern select switch in "Normal" and the shift lever into the D position.
- (d) During a road test (above 10 km/h or 6 mph) check that voltage at the TT terminal is as indicated below for each up-shift position.

If the voltage rises from 0 v to 7 v in the sequence shown, the control system is okay.

The chart on the left shows the voltmeter reading and corresponding gears.

HINT: Determine the gear position by a light shock or change in engine RPM when shifting. The lock-up clutch will turn ON only infrequently during normal 2nd and 3rd gear operation. To trigger this action, press the accelerator pedal to 50% or more of its stroke. At less than 50%, the voltage may change in the sequence 2 V-4 v-6 v-7V.

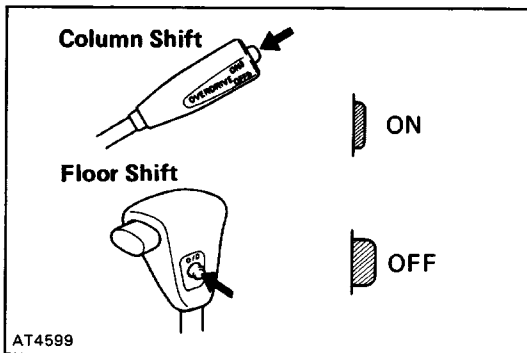

T <sub>T</sub> Terminal (V)	Gear Position
0	1st
2	2nd
3	2nd Lock-up
4	3rd
5	3rd Lock-up
6	O/D
7	O/D Lock-up

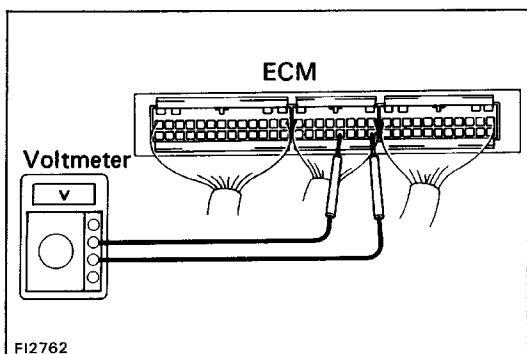

# INSPECTION OF ELECTRONIC CONTROL COMPONENTS

## 1. INSPECT VOLTAGE OF ECM CONNECTOR

- (a) Remove the cowl side trim of passenger side.
- (b) Turn on the ignition switch.
- (c) Measure the voltage at each terminal.

FI2762

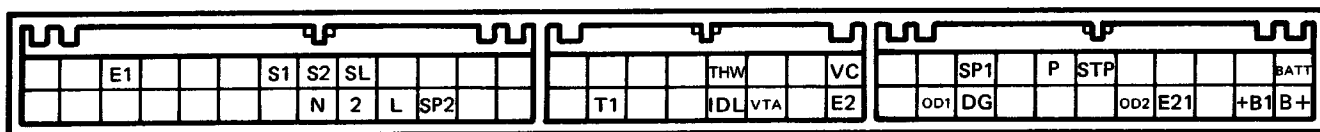

FI2796

Terminal	Measuring condition	Voltage ( V )	
S <sub>1</sub> - E <sub>1</sub>	—	10 - 14	
S <sub>2</sub> , S <sub>L</sub> - E <sub>1</sub>	—	0	
P - E <sub>1</sub>	PWR pattern	10 - 14	
	NORM pattern	0 - 2	
STP - E <sub>1</sub>	Brake pedal is depressed	10 - 14	
	Brake pedal is released	0	
THW - E <sub>2</sub> (E <sub>21</sub> )	Engine coolant temp. 80(°C) (176°F)	0.1 - 1.0	
	Throttle valve fully closed	0	
IDL - E <sub>2</sub> (E <sub>21</sub> )	Throttle valve open	10 - 14	
	Throttle valve fully closed	0.1 - 1.0	
VTA - E <sub>2</sub> (E <sub>21</sub> )	Throttle valve fully open	3 - 5	
	Throttle valve fully closed	0.1 - 1.0	
VC - E <sub>2</sub> (E <sub>21</sub> )	—	4 - 6	
OD <sub>1</sub> - E <sub>1</sub>	—	5	
OD <sub>2</sub> - E <sub>1</sub>	O/D main switch turned ON	10 - 14	
	O/D main switch turned OFF	0	
SP <sub>1</sub> - E <sub>1</sub>	Cruise control main switch OFF	Standing still	0 or 5
		Vehicle moving	2 - 3
SP <sub>2</sub> - E <sub>1</sub>	Standing still	0 or 5	
	Vehicle moving	2 - 3	

Terminal	Measuring condition	Voltage (V)
N - E <sub>1</sub>	N position	10 - 14
	Except N position	0 - 2
2 - E <sub>1</sub>	2 position	10 - 14
	Except 2 position	0 - 2
L - E <sub>1</sub>	L position	10 - 14
	Except L position	0 - 2
B+ (+B <sub>1</sub> ) - E <sub>1</sub>	--	10 - 14
BATT - E <sub>1</sub>	--	10 - 14

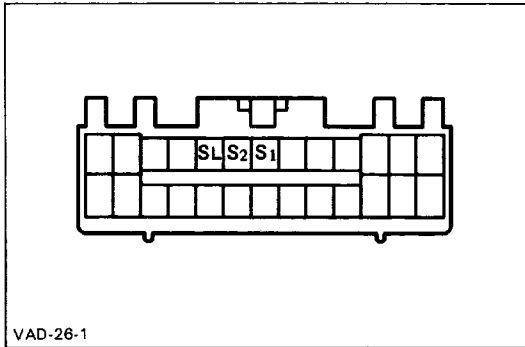

## 2. INSPECT SOLENOID

- Disconnect the connector from ECM.
- Measure the resistance between S, S2, SL and ground.

### Resistance: 11-15

- Apply battery positive voltage to each terminal.  
Check that an operation noise can be heard from the solenoid.

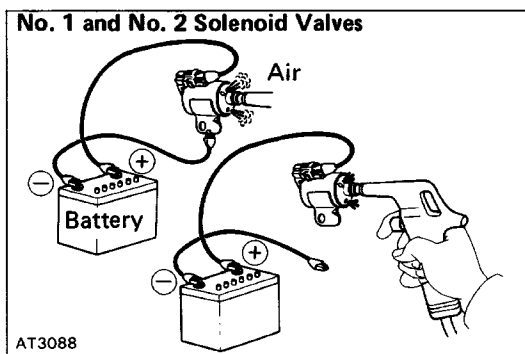

## 3. CHECK SOLENOID SEALS

If there is foreign material in the solenoid valve, there will be no fluid control even with solenoid operation.

- Check No.1 and No.2 solenoid valves.  
Check that the solenoid valves do not leak when low-pressure compressed air is applied.  
When supply battery positive voltage to the solenoids, check that the solenoid valves open.

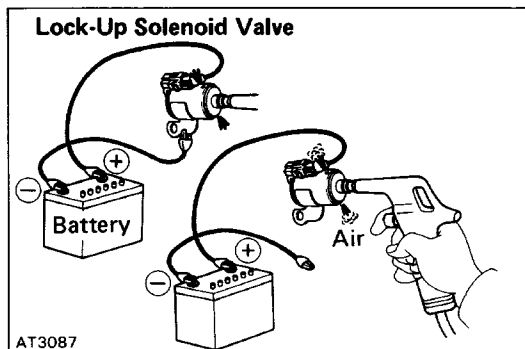

- Check the lock-up solenoid valve.
  - Applying 490 kPa (5 kgf/cm<sup>2</sup>, 71 psi) of compressed air, check that the solenoid valve opens.
  - When supply battery positive voltage to the solenoid, check that the solenoid valve does not leak the air.

If a malfunction is found during voltage inspection (step 1.), inspect the components listed below.

**4. INSPECT PARK/NEUTRAL POSITION SWITCH**

(See page AT-83)

**5. INSPECT THROTTLE POSITION SENSOR**

Using an ohmmeter, check the resistance between each terminal.

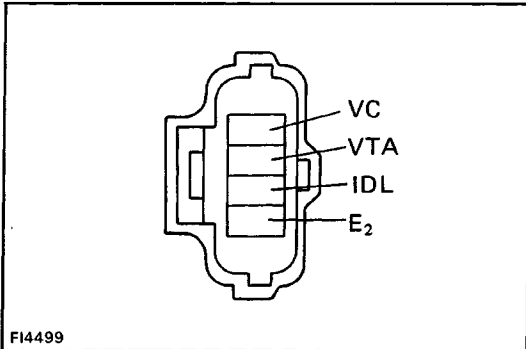

Terminal	Throttle valve condition	Resistance (k/ )
IDL - E <sub>2</sub>	Fully closed	Less than 2.3
	Open	Infinity
VC - E <sub>2</sub>	-	3.9 - 9.0
VTA - E <sub>2</sub>	Fully closed	0.47 - 6.1
	Fully open	3.1 - 12.1

FI4499

**6. INSPECT NO.2 VEHICLE SPEED SENSOR**

- (a) Jack up the rear wheel on one side.
- (b) Connect an ohmmeter between the terminals.
- (c) Spin the wheel and check that the meter needle deflects from 0/ to ∞/ .

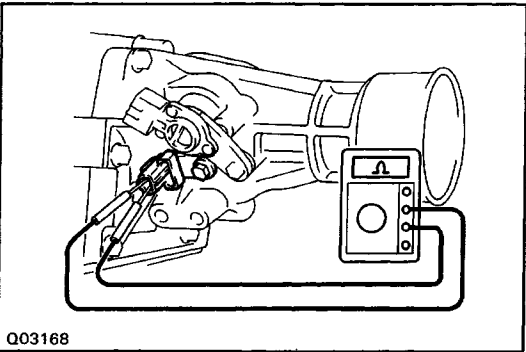

Q03168

**7. INSPECT NO.1 VEHICLE SPEED SENSOR**

(See step 6. on page AT-73)

**8. INSPECT PATTERN SELECT SWITCH**

Using an ohmmeter, check the continuity of terminals for each switch position.

HINT: As there are diodes inside, be careful of the tester probe polarity.

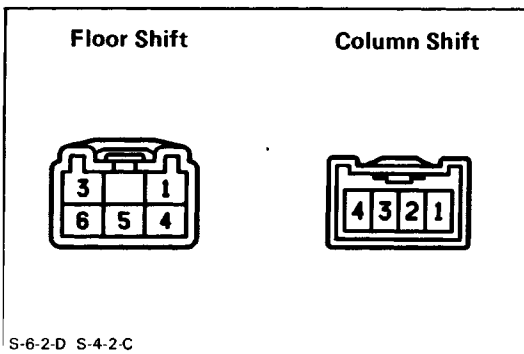

S-6-2-D S-4-2-C

Terminal	Floor shift		Column shift	
	4	6	2	3
Pattern				
PW R	○	○	○	○
NORM				

**9. INSPECT O/D SWITCH ' '**

Using an ohmmeter, check the continuity of the terminals for each switch position.

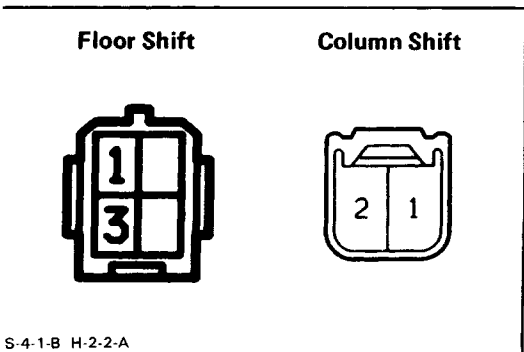

S-4-1-B H-2-2-A

Terminal	1	3(2)
SW position		
ON		
OFF	○	○

**10. INSPECT ENGINE COOLANT TEMPERATURE SENSOR**

(See page FI-200)

# Mechanical System Tests

## STALL TEST

The object of this test is to check the overall performance of the transmission and engine by measuring the stall speeds in the D and R positions.

### NOTICE:

- Perform the test at normal operating fluid temperature (50–80°C or 122–176°F).
- Do not continuously run this test longer than 5 seconds.
- To ensure safety, conduct this test in a wide, clear, level area, which provides good traction.
- The stall test should always be carried out in pairs. One should observe the conditions of wheels or wheel stoppers outside the vehicle while the other is performing the test.

### MEASURE STALL SPEED

- (a) Chock the front and rear wheels.
- (b) Connect a tachometer to the engine.
- (c) Fully apply the parking brake.
- (d) Keep your left foot pressed firmly on the brake pedal.
- (e) Start the engine.
- (f) Shift into the D position. Step all the way down on the accelerator pedal with your right foot.

Quickly read the stall speed at this time.

**NOTICE: Release the accelerator pedal and stop test if the rear wheels begin to rotate before the engine speed reaches specified stall speed.**

**Stall speed: C&C 2,200 ±150 RPM**

**Except: C&C 2,450 ± 150 RPM**

- (g) Perform the same test in R position.

### EVALUATION

- (a) If the stall speed is the same for both positions but lower than specified value:
  - Engine output may be insufficient
  - Stator one-way clutch is not operating properly

HINT: If more than 600 RPM below the specified value, the torque converter clutch could be faulty.

- (b) If the stall speed in D position is higher than specified:
  - Line pressure too low
  - Forward clutch slipping
  - No.2 one-way clutch not operating properly
  - O/D one-way clutch not operating properly
- (c) If the stall speed in R position is higher than specified:
  - Line pressure too low
  - Direct clutch slipping
  - First and reverse brake slipping
  - O/D one-way clutch not operating properly
- (d) If the stall speed in both R and D positions are higher than specified:
  - Line pressure too low
  - Improper fluid level
  - O/D one-way clutch not operating properly

**STALL TEST**

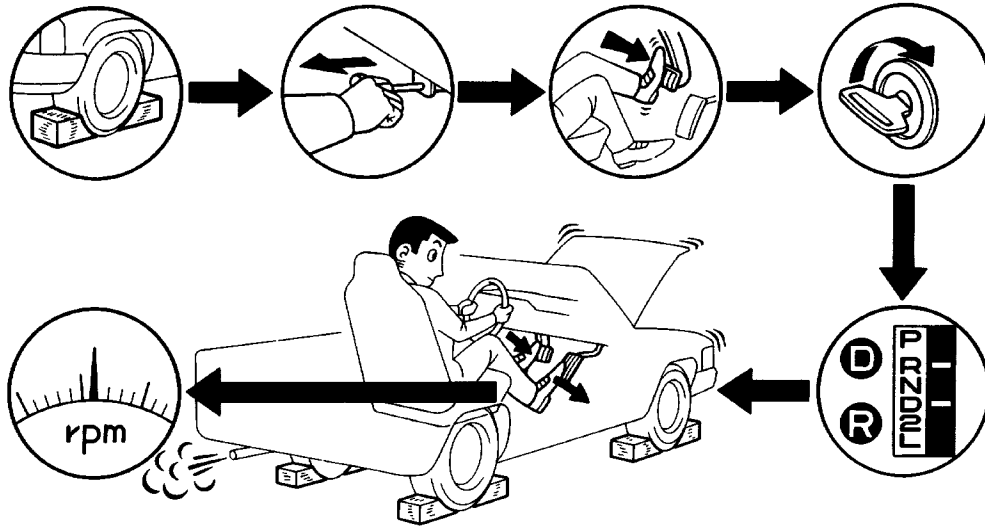

AT1314

**TIME LAG TEST**

When the shift lever is shifted while the engine is idling, there will be a certain time lapse or lag before the shock can be felt. This is used for checking the condition of the O/D direct clutch, forward clutch, direct clutch and first and reverse brake.

**NOTICE:**

- Perform the test at normal operating fluid temperature (50–80°C or 122–176°F).
- Be sure to allow one minute interval between tests.
- Make three measurements and take the average value.

**MEASURE TIME LAG**

- (a) Fully apply the parking brake.
- (b) Start the engine and check the idle speed.  
Idle speed: 800 RPM  
(N position)
- (c) Shift the shift lever from N to D position. Using a stop watch, measure the time it takes from shifting the lever until the shock is felt.  
Time lag: Less than 1.2 seconds
- (d) In same manner, measure the time lag for N–Y R.  
Time lag: Less than 1.5 seconds

**EVALUATION**

- (a) If N–D time lag is longer than specified:
  - Line pressure too low
  - Forward clutch worn
  - O/D one-way clutch not operating properly
- (b) If N–R time lag is longer than specified:
  - Line pressure too low
  - Direct clutch worn
  - First and reverse brake worn
  - O/D one-way clutch not operating properly



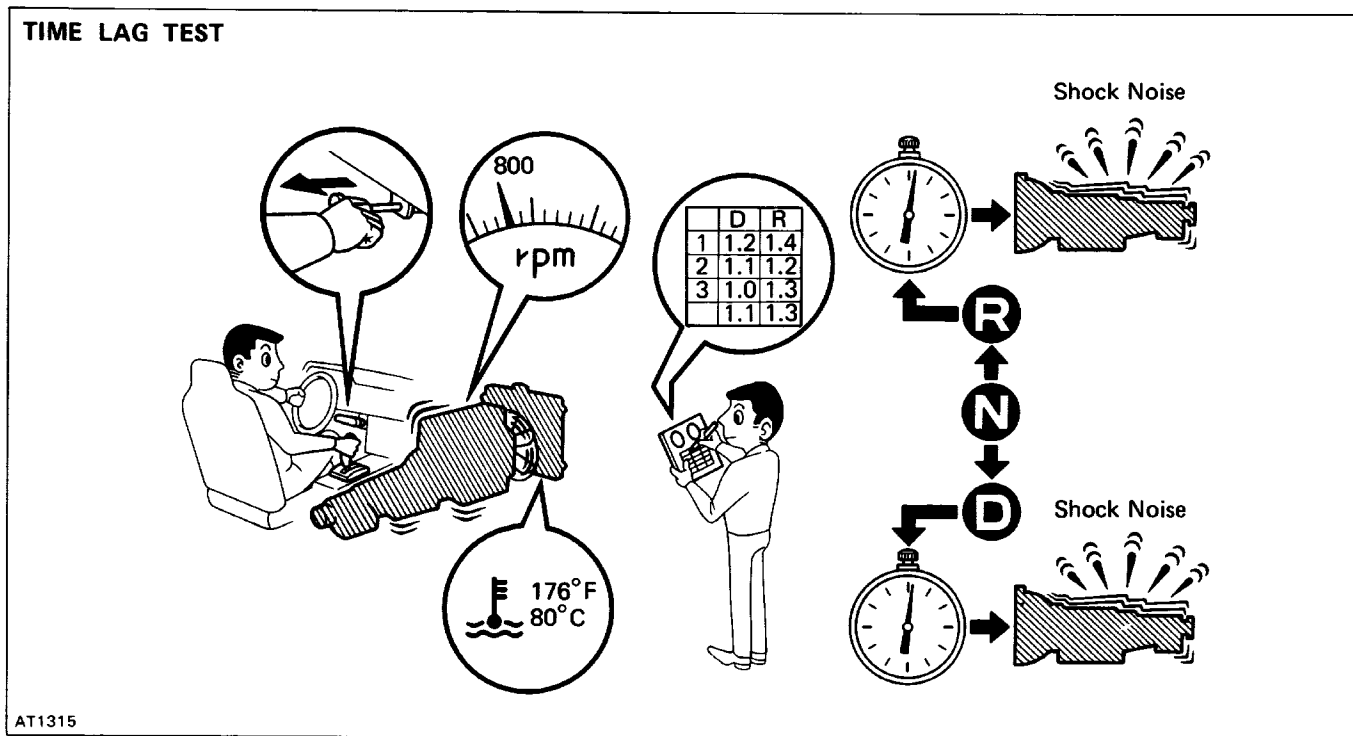

## HYDRAULIC TEST

### PREPARATION

- Warm up the transmission fluid.
- Remove the transmission case test plug and connect the hydraulic pressure gauge.  
SST 09992-00094 (Oil pressure gauge)

### NOTICE:

Perform the test at normal operating fluid temperature (50–80°C or 122–176°F).

The line pressure test should always be carried out in pairs. One should observe the conditions of wheels or wheel stoppers outside the vehicle while the other is performing the test.

### MEASURE LINE PRESSURE

- Fully apply the parking brake and chock the four wheels.
- Start the engine and check idling rpm.
- Keep your left foot pressed firmly on the brake pedal and shift into D position.
- Measure the line pressure when the engine is idling.
- Press the accelerator pedal all the way down. Quickly read the highest line pressure when engine speed reaches stall speed.

**NOTICE: Release the accelerator pedal and stop test if the rear wheels begin to rotate before the engine speed reaches specified stall speed.**

- In the same manner, perform the test in R position.

kPa (kgf/cm<sup>2</sup>,psi)

D position		R position	
Idling	Stall	Idling	Stall
363 – 422 (3.7 – 4.3, 53 – 61)	932 – 1,178 (9.5 – 12.0, 135 – 171)	490 – 588 (5.0 – 6.0, 71 – 85)	1,294 – 1,638 (13.2 – 16.7, 188 – 238)

If the measured pressures are not up to specified values, recheck the throttle cable adjustment and perform a retest.

**EVALUATION**

- (a) If the measured values at all positions are higher than specified:  
 Throttle cable out of adjustment  
 Throttle valve defective  
 Regulator valve defective
- (b) If the measured values at all positions are lower than specified:  
 Throttle cable out of adjustment  
 Throttle valve defective  
 Regulator valve defective  
 Oil pump defective  
 O/D direct clutch defective
- (c) If pressure is low in the D position only:  
 D position circuit fluid leakage  
 Forward clutch defective
- (d) If pressure is low in the R position only:  
 R position circuit fluid leakage  
 Direct clutch defective  
 First and reverse brake defective

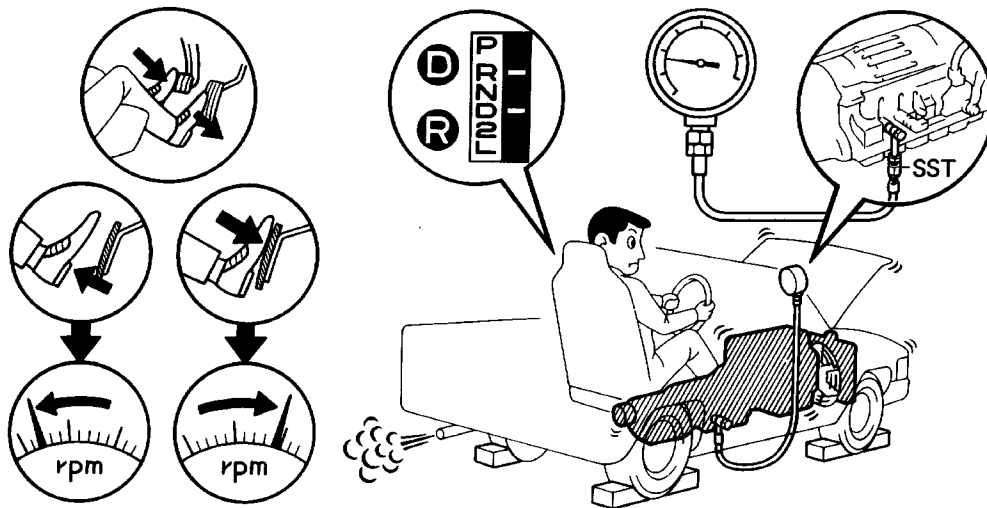
**HYDRAULIC TEST**

## ROAD TEST

**NOTICE:** Perform the test at normal operating fluid temperature (50–80°C or 122–176°F).

### 1. D POSITION TEST IN NORM AND PWR PATTERN RANGES

Shift into the D position and hold the accelerator pedal constant at the full throttle valve opening position.

Check the following:

- (a) 1–2, 2–3 and 3–O/D up-shifts should take place, and shift points should conform to those shown in the automatic shift schedule.

Conduct a test under both Normal and Power patterns.

HINT: There is no O/D up-shift or lock-up when the engine coolant temp. is below 70°C (158°F).

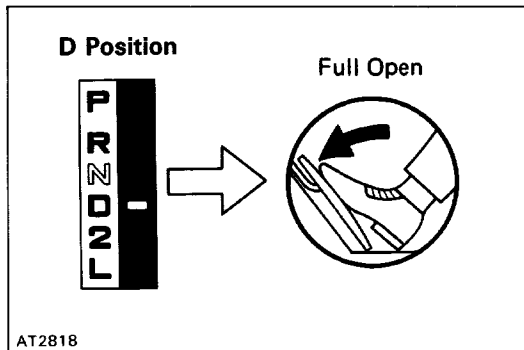

#### EVALUATION

- (1) If there is no 1–2 up-shift:
  - No.2 solenoid is stuck
  - 1–2 shift valve is stuck
- (2) If there is no 2–3 up-shift:
  - No.1 solenoid is stuck
  - 2–3 shift valve is stuck
- (3) If there is no 3–O/D up-shift:
  - 3–4 shift valve is stuck
- (4) If the shift point is defective:
  - Throttle valve, 1–2 shift valve, 2–3 shift valve, 3–4 shift valve etc., are defective
- (5) If the lock-up is defective:
  - Lock-up solenoid is stuck
  - Lock-up relay valve is stuck

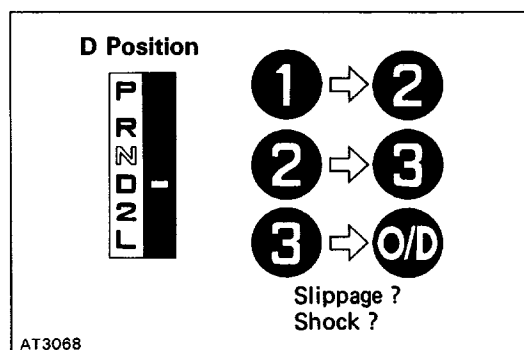

- (b) In the same manner, check the shock and slip at the 1–2, 2–3, and 3–O/D up-shifts.

#### EVALUATION

- If the shock is excessive:
- Line pressure is too high
  - Accumulator is defective
  - Check ball is defective

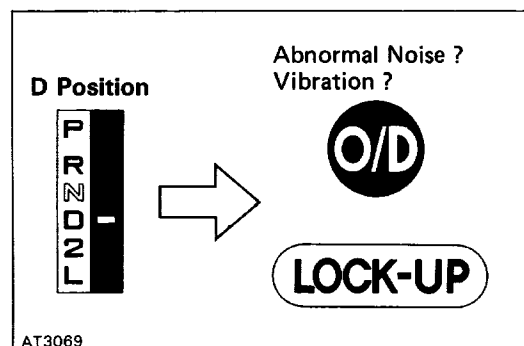

- (c) Run at the D position lock-up or O/D gear and check for abnormal noise and vibration.

HINT: The check for the cause of abnormal noise and vibration must be made with extreme care as it could also be due to loss of balance in the propeller shaft, differential, torque converter clutch, etc.

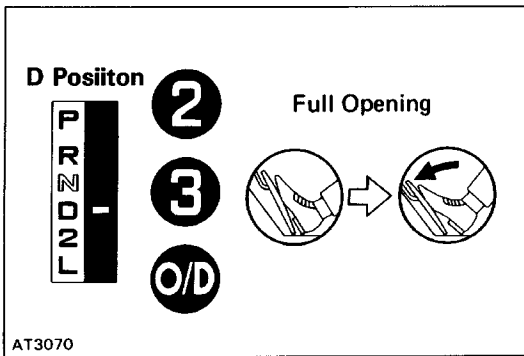

(d) While running in the D position, 2nd, 3rd and O/D gears, check to see the possible kickdown vehicle speed limits for 2 ∞ 1, 3 ∞ 2 and O/D ∞ 3 kickdowns conform to those indicated on the automatic shift schedule.

(e) Check for abnormal shock and slip at kick-down.

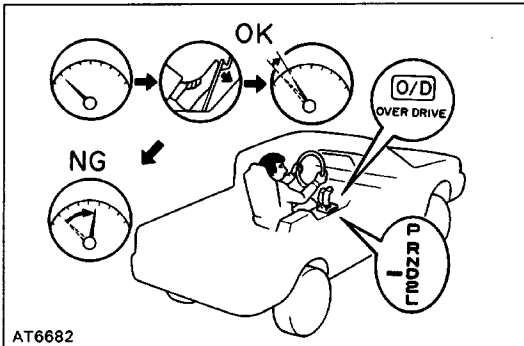

(f) Check for the lock-up mechanism.

(1) Drive in D position, O/D gear, at a steady speed (lock-up ON) of about 75 km/h (47 mph).

(2) Lightly depress the accelerator pedal and check that the engine rpm does not change abruptly.

If there is a big jump in engine rpm, there is no lock-up.

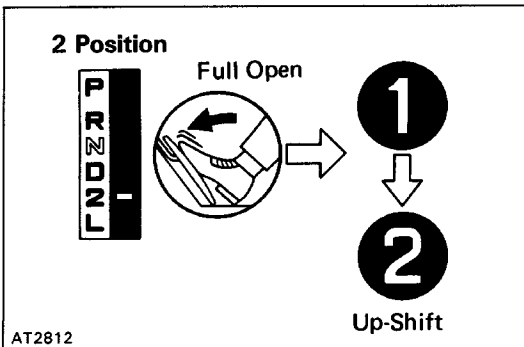

## 2. 2 POSITION TEST

Shift into the 2 position and, while driving with the accelerator pedal held constantly at the full throttle valve opening position, push in one of the pattern selectors and check on the following points.

(a) Check to see that the 1-2 up-shift takes place and that the shift point conforms to it shown on the automatic shift schedule.

HINT:

There is no O/D up-shift and lock-up in the 2 position.

To prevent overrun, the transmission up-shifts into 3rd gear at around 100 km/h (62 mph) or more.

(b) While running in the 2 position and 2nd gear, release the accelerator pedal and check the engine braking effect.

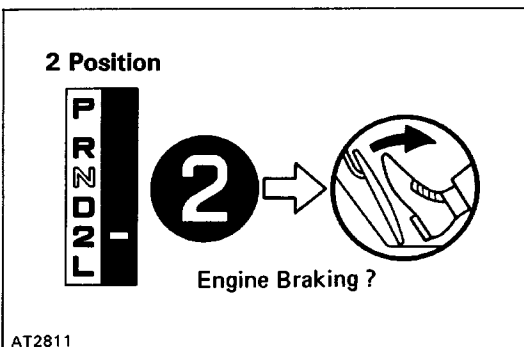

## EVALUATION

If there is no engine braking effect:

Second coast brake is defective

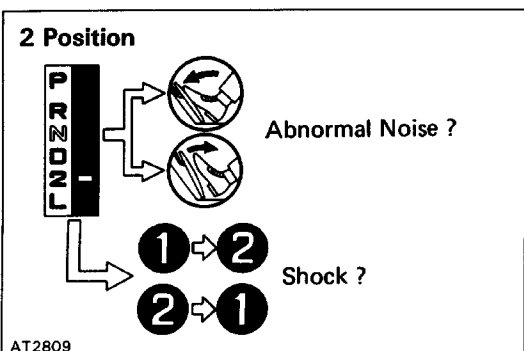

(c) Check for abnormal noise at acceleration and deceleration, and for shock at up-shift and down-shift.

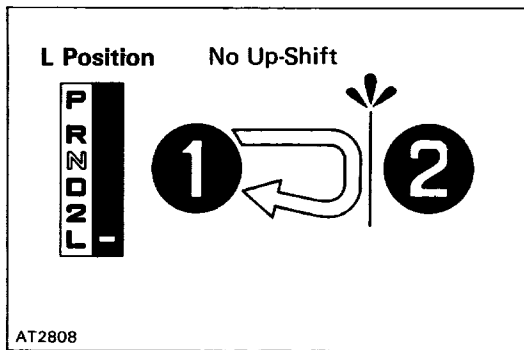

### 3. L POSITION TEST

- (a) While running in the L position, check to see that there is no up-shift to 2nd gear.

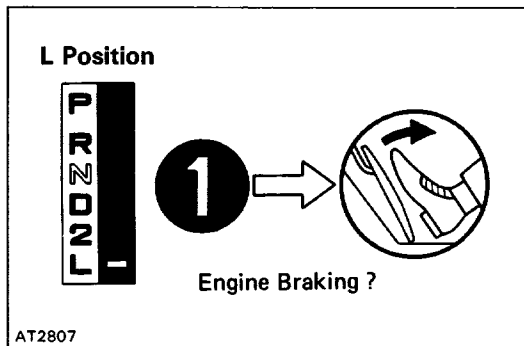

- (b) While running in the L position, release the accelerator pedal and check the engine braking effect.

#### EVALUATION

If there is no engine braking effect:

First and reverse brake is defective

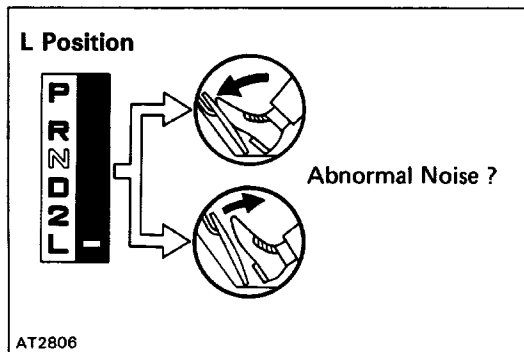

- (c) Check for abnormal noise during acceleration and deceleration.

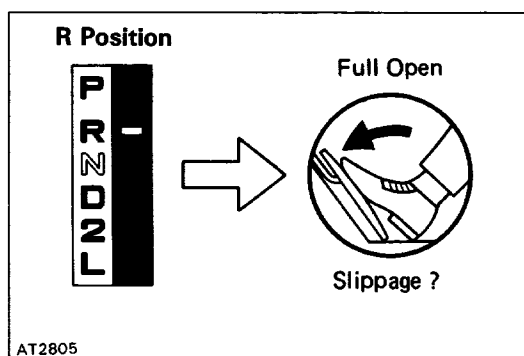

### 4. R POSITION TEST

Shift into the R position and, while starting at wide open throttle, check for slippage.

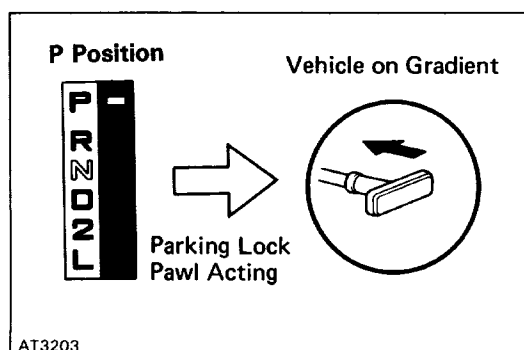

### 5. P POSITION TEST

Stop the vehicle on a gradient (more than 50) and after shifting into the P position, release the parking brake.

Then check to see that the parking lock pawl holds the vehicle in place.

# Automatic Shift Schedule

CBU: Tire size P205175R14, P215/65R15

(Differential gear ratio: 3.417)

		Throttle valve fully open [ ] Fully closed						km/h (mph)	
		1→2	2→3	3→O/D	[3→O/D]	[O/D→3]	O/D→3	3→2	2→1
D position	NORM	61-66 (38-41)	108-117 (67-73)	143-152 (89-94)	43-48 (27-30)	26-30 (16-19)	136-145 (85-90)	100-105 (62-65)	44-49 (27-30)
	PW R	61-66 (38-41)	119-127 (74-79)	147-156 (91-97)	47-52 (29-32)	26-30 (16-19)	140-149 (87-93)	110-119 (68-74)	44-49 (27-30)
2 position	NORM PW R	53-57 (33-35)	126-135 (78-84)	-	-	-	-	119-128 (74-80)	47-52 (29-32)
L position	NORM PW R	-	-	-	-	-	-	101-110 (63-68)	57-62 (35-39)

		Throttle valve opening 5%						km/h (mph)		
		Lock-up ON			Lock-up OFF					
		2nd	*3rd	O/D	2nd	*3rd	O/D			
D position	NORM	-	79-83 (49-52)	79-83 (49-52)	-	71-76 (44-47)	68-73 (42-45)			
	PW R	-	61-66 (38-41)	79-83 (49-52)	-	68-73 (42-45)	68-76 (42-47)			

\* O/D switch OFF

CBU : Tire size 185R14-8

(Differential gear ratio: 3.9001)

		Throttle valve fully open [ ] Fully closed						km/h (mph)	
		1→2	2→3	3→O/D	[3→O/D]	[O/D→3]	O/D→3	3→2	2→1
D position	NORM	52-56 (32-35)	93-100 (45-62)	135-142 (84-88)	37-41 (23-25)	22-26 (14-16)	130-136 (81-85)	86-90 (53-56)	43-47 (27-29)
	PW R	52-56 (32-35)	102-109 (63-68)	148-154 (92-96)	40-44 (25-27)	22-26 (14-16)	141-148 (88-92)	95-102 (59-63)	43-47 (27-29)
2 position	NORM PW R	45-49 (28-30)	108-115 (67-71)	-	-	-	-	102-109 (63-68)	40-44 (25-27)
L position	NORM PW R	-	-	-	-	-	-	87-94 (54-58)	49-53 (30-33)

		Throttle valve opening 5%						km/h (mph)		
		Lock-up ON			Lock-up OFF					
		2nd	*3rd	O/D	2nd	*3rd	O/D			
D position	NORM	-	67-71 (42-44)	68-71 (42-44)	-	61-65 (38-40)	58-62 (36-39)			
	PW R	-	58-62 (36-39)	68-71 (42-44)	-	52-56 (32-35)	61-65 (38-40)			

\* : O/D switch OFF

**C & C: Tire size 185R14-8, 185R14-6 (Double tire)****(Differential gear ratio: 4.100)**

		Throttle valve fully open			[ ] Fully closed			km/h (mph)	
		1→2	2→3	3→O/D	[3→O/D]	[O/D→3]	O/D→3	3→2	2→1
D position	NORM	43-47 (27-29)	84-91 (52-57)	129-135 (80-84)	73-77 (45-48)	21-25 (13-16)	123-130 (76-81)	77-81 (48-50)	38-42 (24-26)
	PWR	51-55 (32-34)	97-103 (60-64)	132-138 (82-86)	73-77 (45-48)	21-25 (13-16)	126-132 (78-82)	90-97 (56-60)	45-48 (28-30)
2 position	NORM PWR	43-47 (27-29)	103-110 (64-68)	—	—	—	—	97-104 (60-65)	38-42 (24-26)
L position	NORM PWR	—	—	—	—	—	—	83-89 (52-55)	47-51 (29-32)

		Throttle valve opening 5%						km/h (mph)		
		Lock-up ON			Lock-up OFF					
		2nd	*3rd	O/D	2nd	*3rd	O/D			
D position	NORM	—	73-77 (45-48)	73-77 (45-48)	—	61-65 (38-40)	67-71 (42-44)			
	PWR	—	73-77 (45-48)	73-77 (45-48)	—	67-71 (42-44)	67-71 (42-44)			

\* : O/D switch OFF

**C & C: Tire size 185R14-6 (Double tire)****(Differential gear ratio: 4.300)**

		Throttle valve fully open			[ ] Fully closed			km/h (mph)	
		1→2	2→3	3→O/D	[3→O/D]	[O/D→3]	O/D→3	3→2	2→1
D position	NORM	41-45 (25-28)	80-87 (50-54)	123-129 (76-80)	69-73 (43-45)	20-24 (12-15)	117-124 (73-77)	73-77 (45-48)	37-40 (23-25)
	PWR	49-53 (30-33)	92-99 (57-62)	126-132 (78-82)	69-73 (43-45)	20-24 (12-15)	120-126 (75-78)	86-92 (53-57)	42-46 (26-29)
2 position	NORM PWR	41-45 (25-28)	98-105 (61-65)	—	—	—	—	93-99 (58-62)	37-40 (23-25)
L position	NORM PWR	—	—	—	—	—	—	79-85 (49-53)	45-48 (28-30)

		Throttle valve opening 5%						km/h (mph)		
		Lock-up ON			Lock-up OFF					
		2nd	*3rd	O/D	2nd	*3rd	O/D			
D position	NORM	—	69-73 (43-45)	69-73 (43-45)	—	58-62 (36-39)	64-68 (40-42)			
	PWR	—	69-73 (43-45)	69-73 (43-45)	—	64-68 (40-42)	64-68 (40-42)			

\* : O/D switch OFF

**HINT:**

- (1) Lock-up will not occur in 2nd gear unless the throttle valve opening is greater than 50%.
- (2) There is no lock-up in the 2 and L positions.
- (3) In the following cases, the lock-up will be released regardless of the lock-up pattern.
  - When the throttle is completely closed.
  - When the brake light switch is ON.





## ON-VEHICLE REPAIR

### Valve Body

#### REMOVAL OF VALVE BODY

##### 1. CLEAN TRANSMISSION EXTERIOR

To prevent contamination, clean the exterior of the transmission.

##### 2. DRAIN TRANSMISSION FLUID

Remove the drain plug and the fluid into a suitable container.

##### 3. REMOVE OIL PAN

**NOTICE:** Some fluid will remain in the oil pan. Be careful not to damage the filler tube and O-ring.

(a) Remove the nineteen bolts.

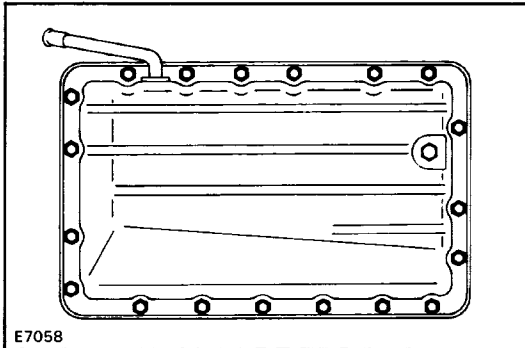

(b) Install the blade of SST between the transmission case and oil pan, cut off applied sealer and then remove the oil pan.

SST 09032-00100

**NOTICE:** When removing the oil pan, be careful not to damage the oil pan flange.

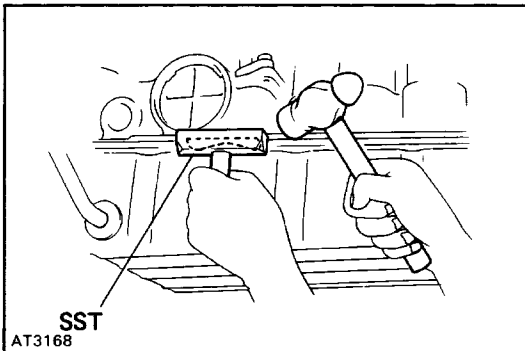

##### 4. REMOVE OIL STRAINER

Remove the six bolts, and the oil strainer.

**NOTICE:** Be careful as some oil will come out with the filter

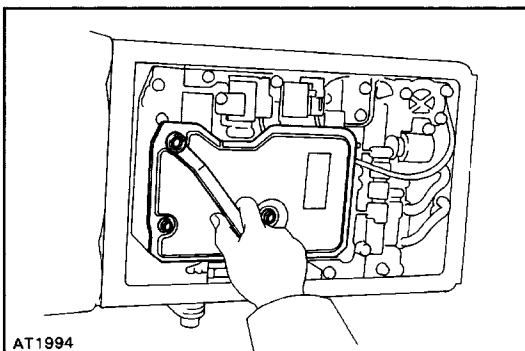

##### 5. REMOVE OIL TUBES

Pry up both tube ends with a large screwdriver and remove the tubes.

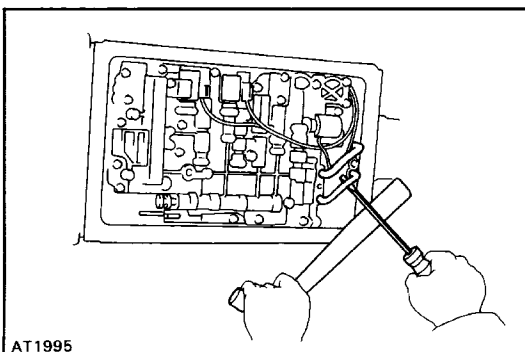

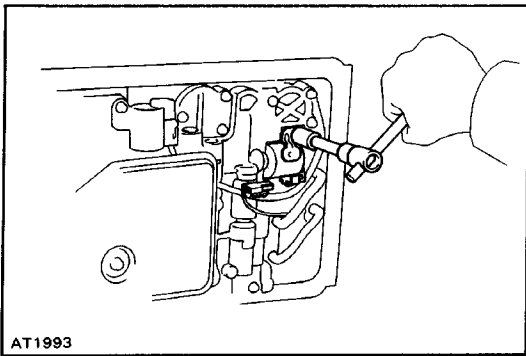

**6. WHEN REPLACING SOLENOIDS**

- (a) Disconnect the connectors from the solenoids.
- (b) Remove the solenoid mounting bolts.
- (c) Remove the solenoids.

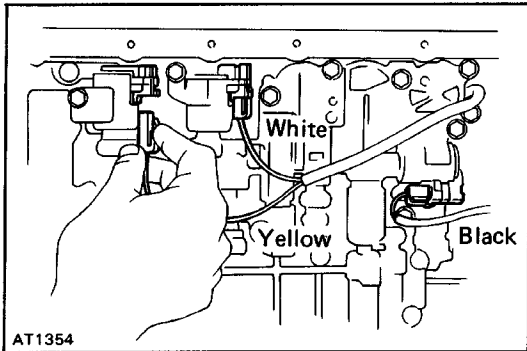

**7. DISCONNECT SOLENOID CONNECTORS**

Disconnect the three connectors from No.1, No.2 and lock-up solenoids.

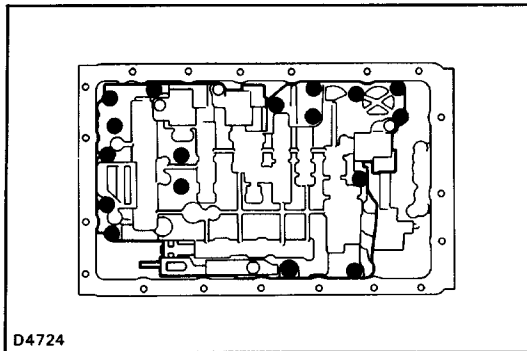

**8. REMOVE VALVE BODY**

- (a) Remove the seventeen bolts.

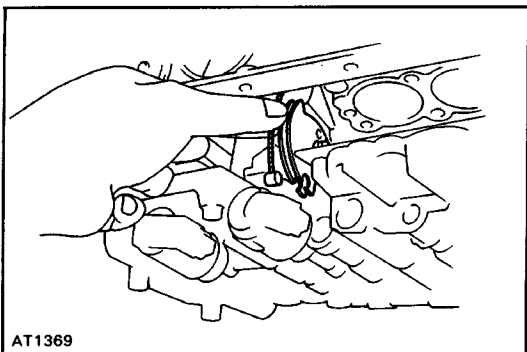

- (b) Disconnect the throttle cable from the cam and remove the valve body.

**INSTALLATION OF VALVE BODY**

**1. CONNECT THROTTLE CABLE TO CAM**

Push the cable fitting into the cam.

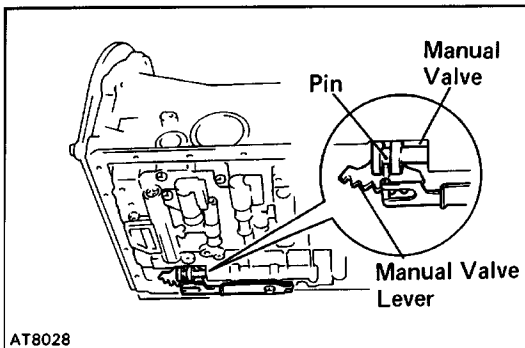

**2. INSTALL VALVE BODY**

- (a) Align the manual valve lever with the manual valve.

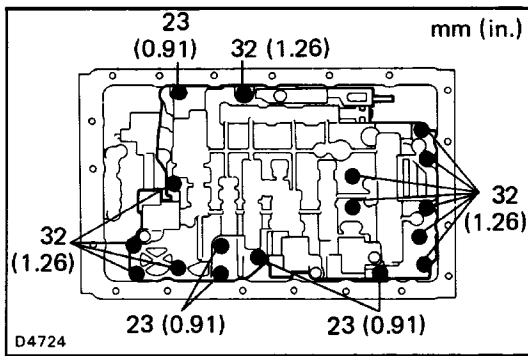

(b) Finger tighten the all bolts first. Then tighten the bolts evenly.  
 HINT: Each bolt length (mm, in.) is indicated in the figure.

**Torque: 10 N-m (100 kgf-cm, 7 ft-lbf)**

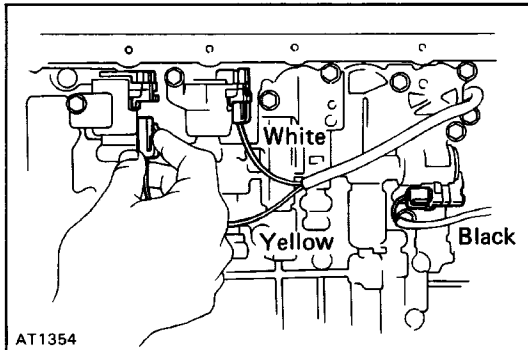

**3. CONNECT SOLENOID WIRING**

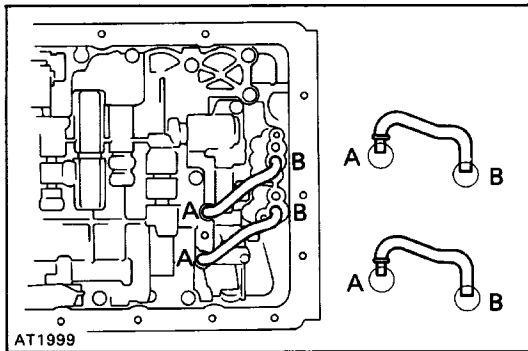

**4. INSTALL OIL TUBES**

Tap the tubes with a plastic hammer to install them into the positions in the figure.

**NOTICE: Be careful not to bend or damage the tubes.**

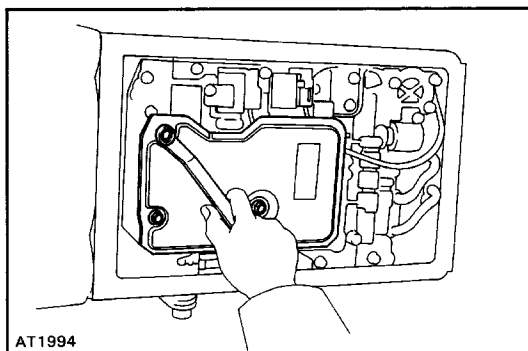

**5. INSTALL OIL STRAINER**

Be sure the screen is clean. Torque the bolts.

**Torque: 5.4 N-m (55 kgf-cm, 48 in.ζlbf)**

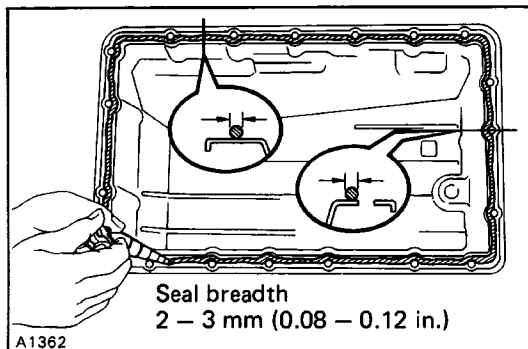

**6. INSTALL OIL PAN**

(a) Remove any packing material and be careful not to drop oil on the contacting surfaces of the transmission case and oil pan.

(b) Apply seal packing to the oil pan shown in the figure.

**Seal packing: Part No. 08826-00090, THREE BOND 1281 or equivalent**

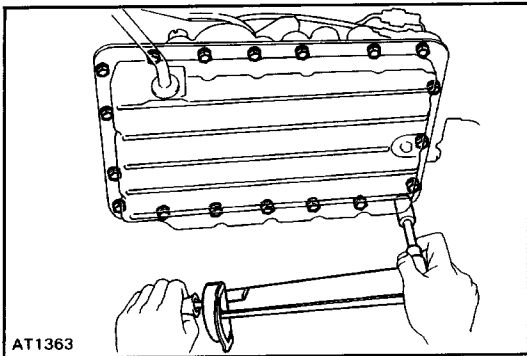

(c) Install and torque the nineteen bolts.  
**Torque: 7.4 N-m (70 kgf-cm, 65 in.-lbf)**

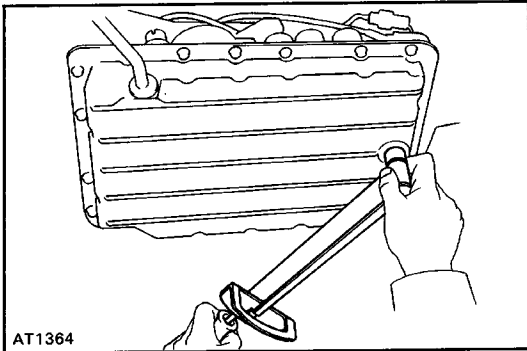

**7. INSTALL DRAIN PLUG**

Torque the drain plug.

**Torque: 20 N-m (205 kgf-cm, 15 ft-lbf)**

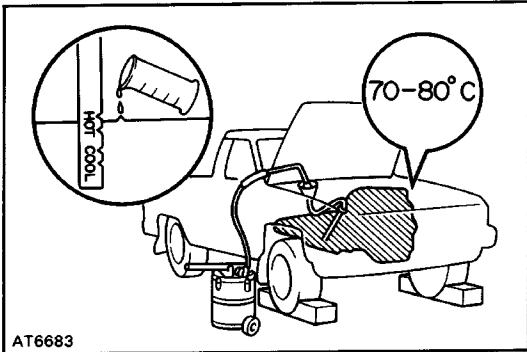

**8. FILL TRANSMISSION WITH ATF**

Add only about two liters of ATF. Start the engine and shift through all the positions. Check the fluid level and add as necessary.

**NOTICE: Do not overfill.**

**Fluid type: ATF DEXRON® II**

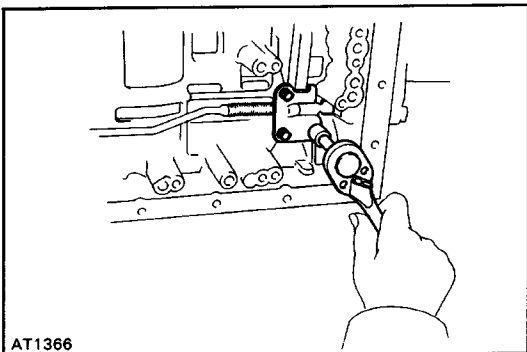

**Parking Lock Pawl**

**REMOVAL OF PARKING LOCK PAWL**

1. REMOVE VALVE BODY (See page [AT-84](#))
2. REMOVE PARKING LOCK PAWL BRACKET  
 Remove the three bolts and the bracket.

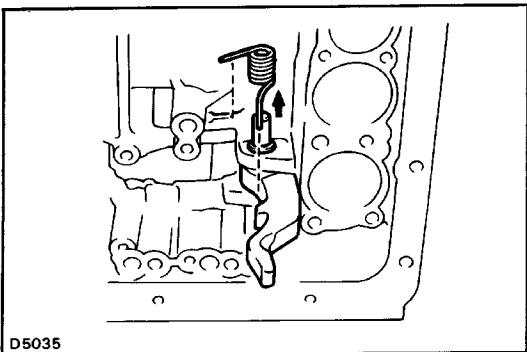

3. REMOVE SPRING FROM PARKING LOCK PAWL PIVOT PIN
4. REMOVE PIVOT PIN AND PARKING LOCK PAWL

**INSTALLATION OF PARKING LOCK PAWL**

1. INSTALL PARKING LOCK PAWL AND PIVOT PIN
2. INSTALL SPRING

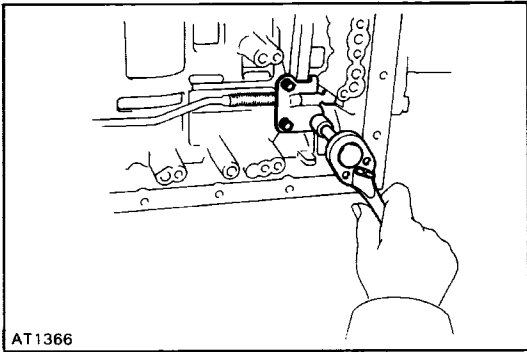

AT1366

### 3. INSTALL PARKING LOCK PAWL BRACKET

- (a) Push lock rod fully toward.
- (b) Install the three bolts finger tight.
- (c) Check that the pawl operates smoothly.
- (d) Torque the bolts.

**Torque: 7.4 N-m (70 kgf-cm, 65 in.·lbf)**

### 4. INSTALL VALVE BODY (See page AT-85)

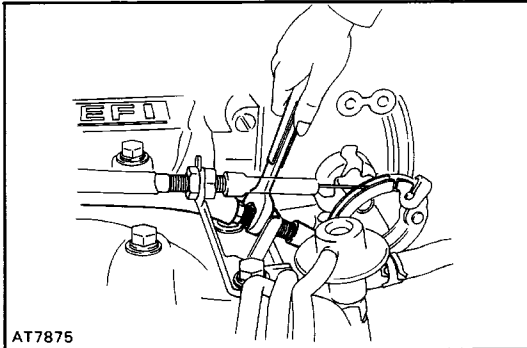

AT7875

## Throttle Cable

### REMOVAL OF THROTTLE CABLE

#### 1. DISCONNECT THROTTLE CABLE

- (a) Disconnect the cable housing from the bracket.
- (b) Disconnect the cable from the throttle linkage.

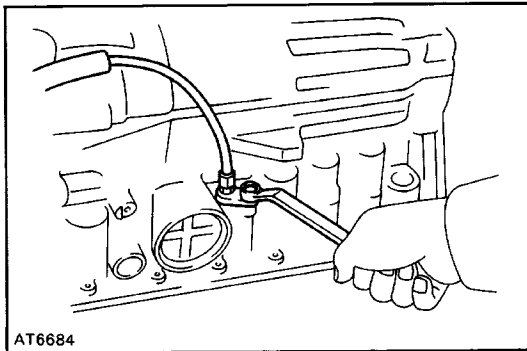

AT6684

#### 2. REMOVE VALVE BODY (See page AT-84)

#### 3. PUSH THROTTLE CABLE OUT OF TRANSMISSION CASE

Remove the retaining bolt and pull out the throttle cable.

### INSTALLATION OF THROTTLE CABLE

#### 1. INSTALL CABLE IN TRANSMISSION CASE

Install the retaining bolt and push in the throttle cable.

#### 2. INSTALL VALVE BODY (See page AT-85)

#### 3. IF THROTTLE CABLE IS NEW, STAKE STOPPER ON INNER CABLE

- (a) Pull the inner cable lightly until a slight resistance is felt, and hold it.
- (b) Stake the stopper as shown, 0.8–1.5 mm (0.031–0.059 in.) in width.

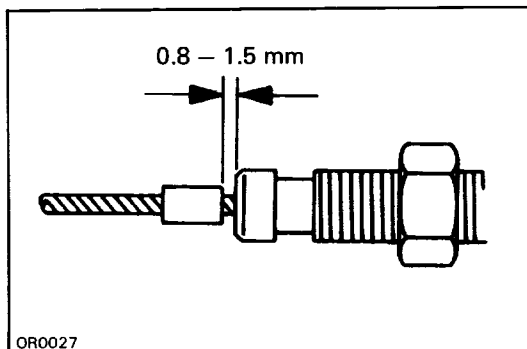

OR0027

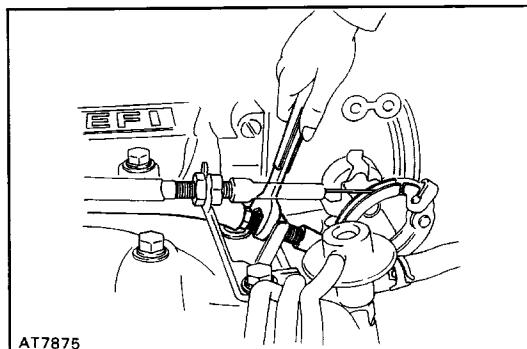

AT7875

#### 4. CONNECT THROTTLE CABLE

- (a) Connect the cable to the throttle linkage.
- (b) Connect the cable housing to the bracket.

#### 5. ADJUST THROTTLE CABLE (See page AT-60)

#### 6. TEST DRIVE VEHICLE

## Extension Housing REPLACEMENT OF OIL SEAL

1. RAISE VEHICLE, AND POSITION PAN TO CATCH ANY FLUID THAT MAY DRIP
2. REMOVE PROPELLER SHAFT  
(See page [PR-3](#))

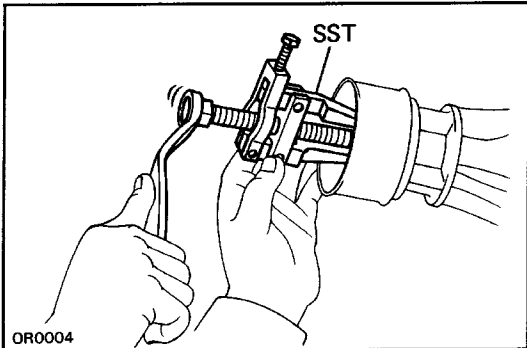

3. REMOVE REAR OIL SEAL

**NOTICE:** Clean the rear extension housing before removing the seal.

Using SST, remove the oil seal.  
SST 09308-10010

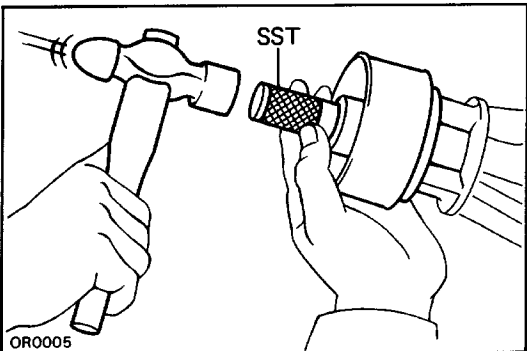

4. INSTALL NEW OIL SEAL

Using SST, drive in a new oil seal as far as it will go.  
SST 0932 5-20010

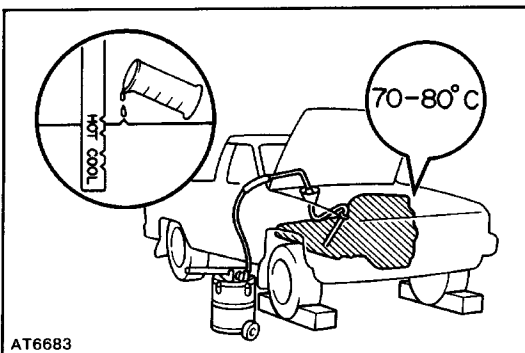

5. INSTALL PROPELLER SHAFT

(See page [PR-3](#))

6. LOWER VEHICLE AND CHECK FLUID LEVEL

Start the engine, shift the shift lever into each position and, then check the fluid level with the transmission in P position.

Add fluid as necessary.

**NOTICE:** Do not overfill.

Fluid type: ATF DEXRON<sup>®</sup> II

## REMOVAL OF EXTENSION HOUSING

1. RAISE VEHICLE AND POSITION PAN TO CATCH ANY FLUID THAT MAY DRIP
2. REMOVE PROPELLER SHAFT  
(See page [PR-3](#))

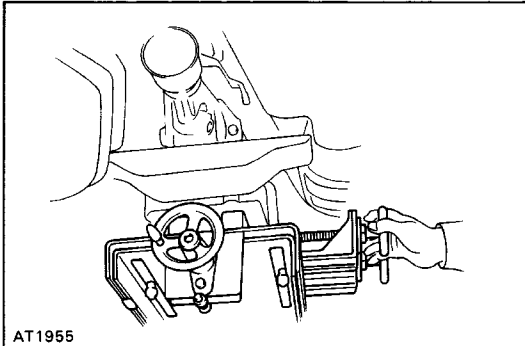

AT1955

### 3. JACK UP TRANSMISSION SLIGHTLY

Securely support the transmission on a transmission jack. Lift the transmission slightly to remove weight from the rear support member.

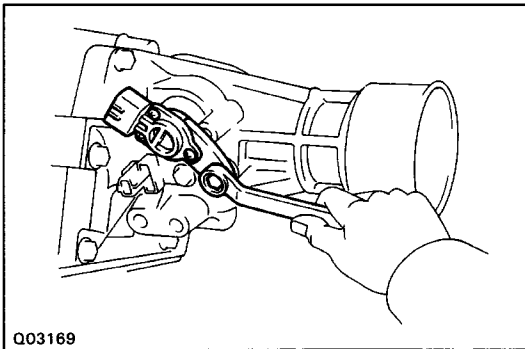

Q03169

### 4. REMOVE NO. 1 VEHICLE SPEED SENSOR

- (a) Disconnect the connector.
- (b) Remove the bolt and pry out the No. 1 vehicle speed sensor with a screwdriver.
- (c) Remove the O-ring from the sensor.

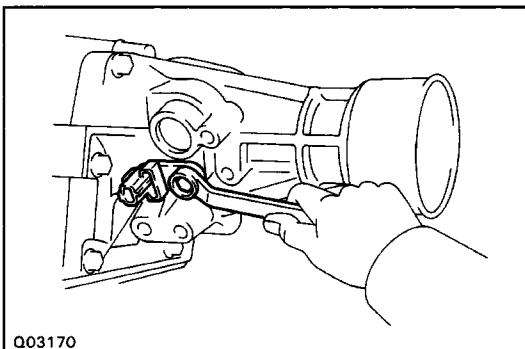

Q03170

### 5. REMOVE NO.2 VEHICLE SPEED SENSOR

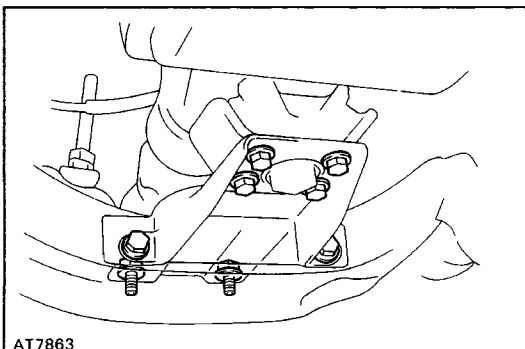

AT7863

### 6. REMOVE ENGINE REAR MOUNTING FROM BRACKET

Remove eight bolts from the bracket.

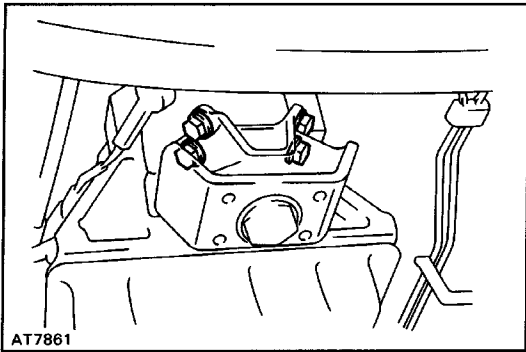

**7. REMOVE ENGINE REAR MOUNTING FROM EXTENSION HOUSING**

Remove four bolts and the engine rear mounting from the extension housing.

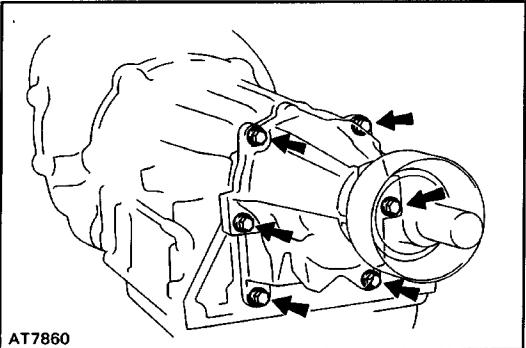

**8. REMOVE EXTENSION HOUSING AND GASKET**

Remove the six bolts. If necessary, tap the extension housing with a plastic hammer or wooden block to loosen it.

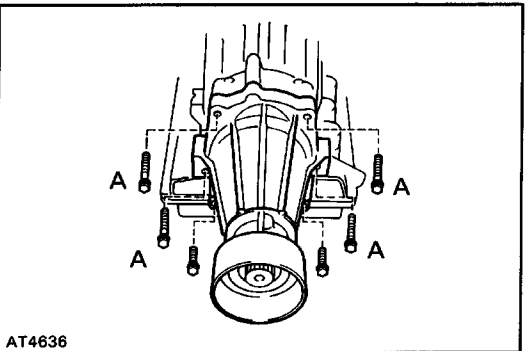

**INSTALLATION OF EXTENSION HOUSING**

**1. INSTALL NEW GASKET AND EXTENSION HOUSING ON TRANSMISSION**

- (a) Clean the threads of the A bolt and bolt hole.
- (b) Coat the threads of the A bolt with sealant.  
Sealant: Part No. 08833-00080, THREE BOND 1344, LOCTITE 242 or equivalent
- (c) Install the extension housing over a new gasket with bolts, and then torque them.

HINT: The two lower bolts are shorter.

**Torque: 34 N-m (345 kgf-cm, 25 ft-lbf)**

**2. INSTALL ENGINE REAR MOUNTING**

- (a) Install the engine rear mounting to the extension housing. Tighten the four bolts.

**Torque: 25 N-m (250 kgf-cm, 18 ft-lbf)**

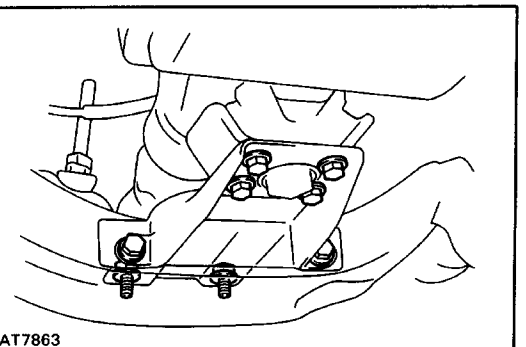
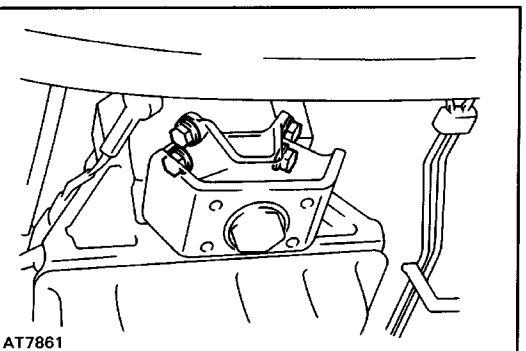

- (b) Connect the bracket to the rear mounting and tighten the four bolts.

**Torque: 13 N-m (130 kgf-cm, 9 ft-lbf )**



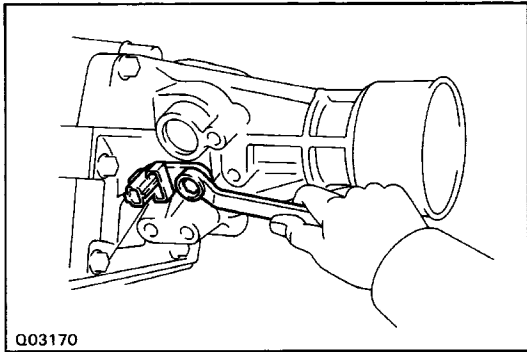

Q03170

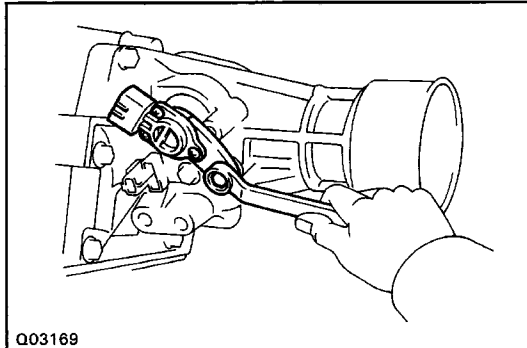

Q03169

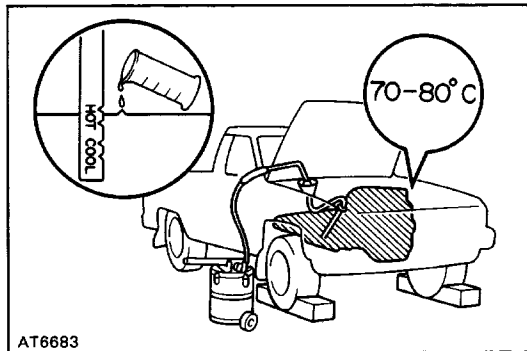

AT6683

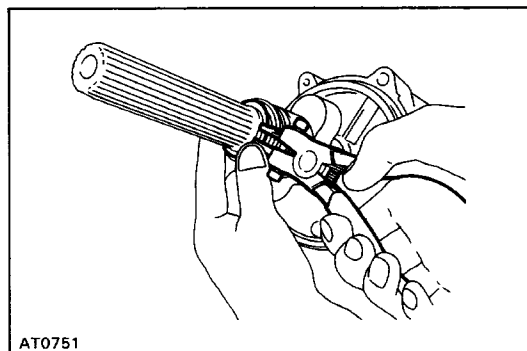

AT0751

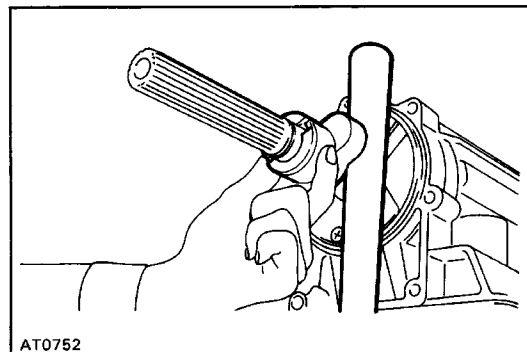

AT0752

### 3. INSTALL NO.2 VEHICLE SPEED SENSOR

### 4. INSTALL PROPELLER SHAFT

(See page [PR-3](#))

### 5. INSTALL NO. 1 VEHICLE SPEED SENSOR

- (a) Install a new O-ring on the sensor.
- (b) Install the No. 1 vehicle speed sensor.

### 6. CONNECT CONNECTOR

### 7. LOWER VEHICLE AND CHECK FLUID LEVEL

Start the engine, shift the shift lever into each position, and then check the fluid level with the transmission in P position.

Add fluid as necessary.

**NOTICE:** Do not overfill.

Fluid type: ATF DEXRON® 11

## Sensor Rotor

### REMOVAL OF SENSOR ROTOR

#### 1. REMOVE EXTENSION HOUSING

(See page [AT-90](#))

#### 2. REMOVE SPEEDOMETER DRIVE GEAR

- (a) Using snap ring pliers, remove the snap ring.
- (b) Slide off the speedometer drive gear.
- (e) Remove the lock ball.

#### 3. REMOVE SENSOR ROTOR FROM OUTPUT SHAFT

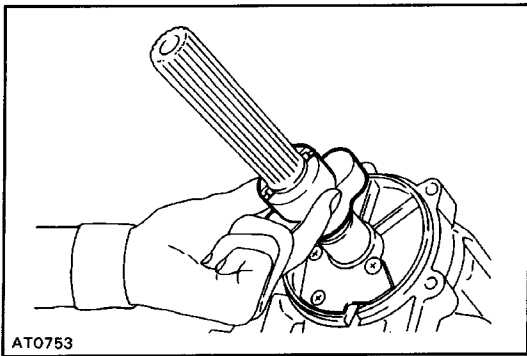

## INSTALLATION OF SENSOR ROTOR

### 1. INSTALL SENSOR ROTOR ON OUTPUT SHAFT

- (a) Make sure that the key is installed in the groove.
- (b) Install the sensor rotor on the shaft.

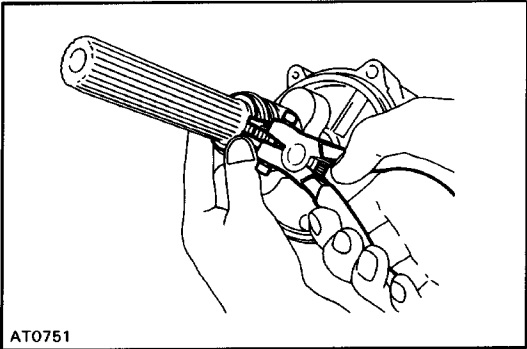

### 2. INSTALL SPEEDOMETER DRIVE GEAR

- (a) Slide the lock ball and the speedometer drive gear on the output shaft.
- (b) Using snap ring pliers, install the snap ring.

### 3. INSTALL EXTENSION HOUSING

(See page [AT-91](#))

# REMOVAL AND INSTALLATION OF TRANSMISSION

Remove and install the parts as shown.

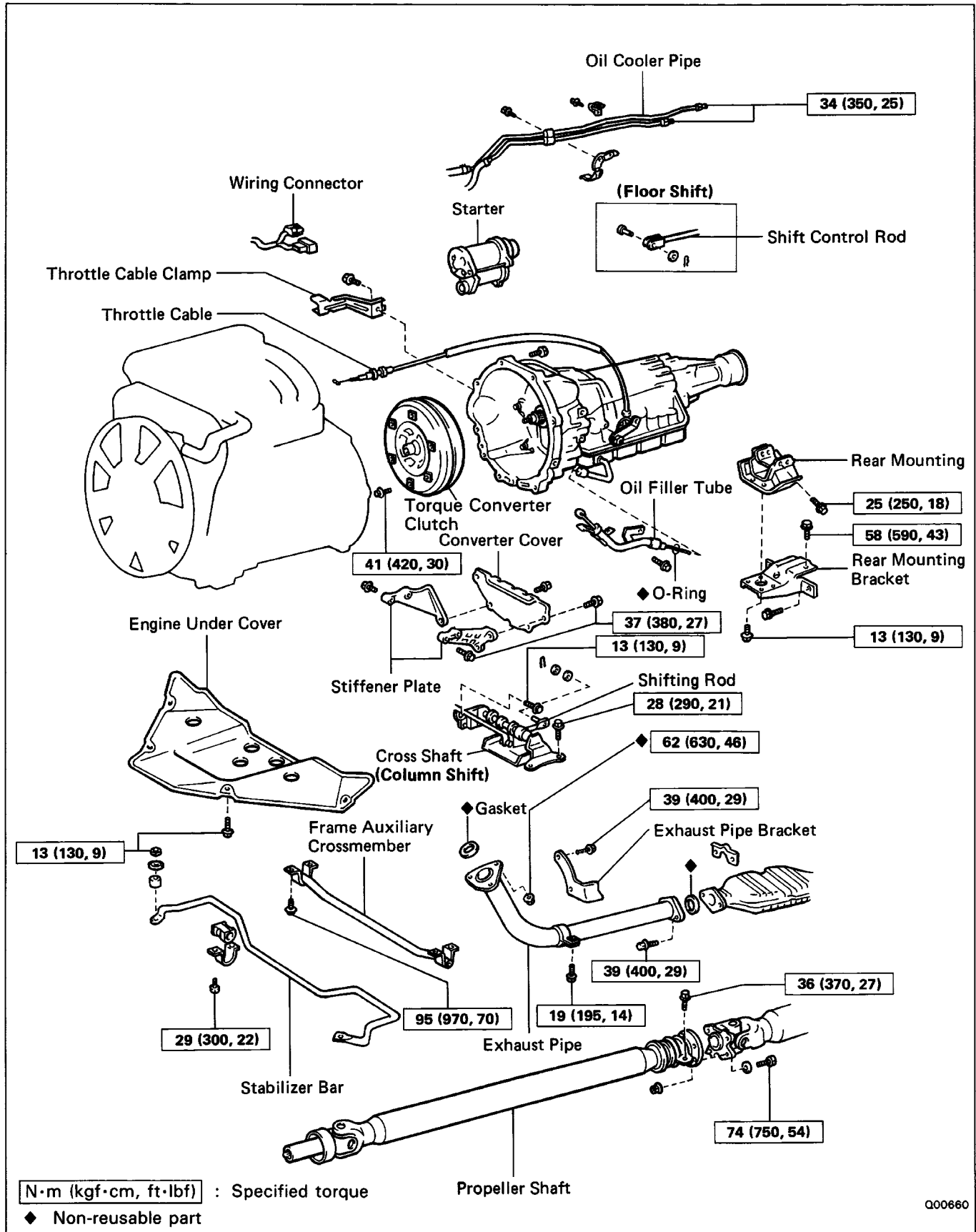

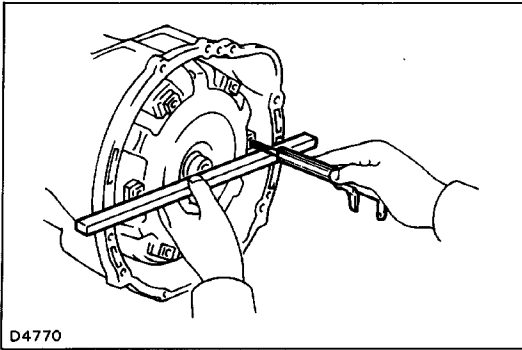

## (MAIN POINT OF INSTALLATION)

### 1. CHECK TORQUE CONVERTER CLUTCH INSTALLATION

Using calipers and a straight edge, measure from the installed surface of the torque converter clutch to the front surface of the transmission housing.

**Correct distance: 18.0 mm (0.709 in.)**

If the distance is less than the standard, check for an improper installation.

### 2. ADJUST TRANSMISSION THROTTLE CABLE

(See page [AT-60](#))

### 3. FILL TRANSMISSION WITH ATF AND CHECK FLUID LEVEL

Fluid type: ATF DEXRON® II

**NOTICE:** Do not overfill.

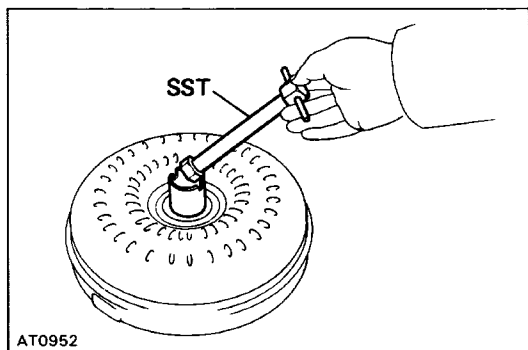

AT0952

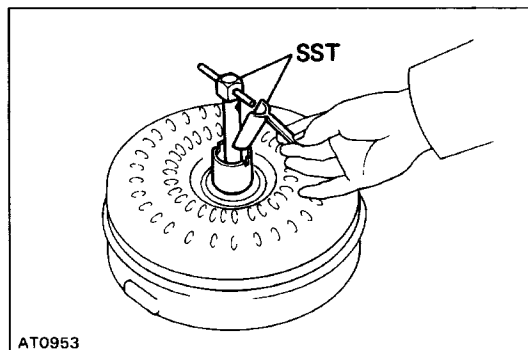

AT0953

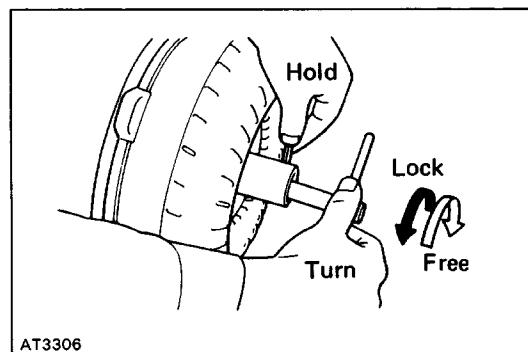

AT3306

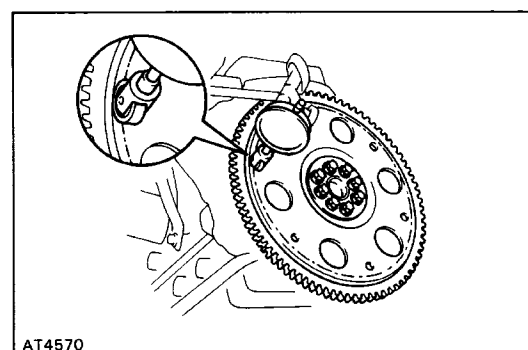

AT4570

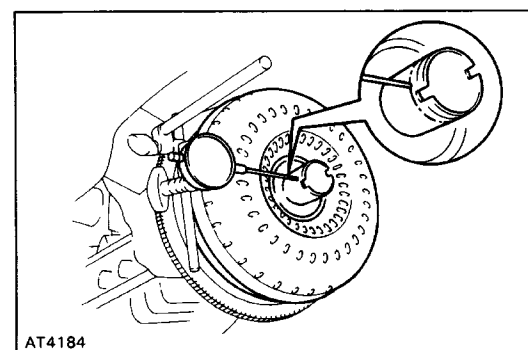

AT4184

# TORQUE CONVERTER CLUTCH AND DRIVE PLATE

## INSPECTION OF TORQUE CONVERTER CLUTCH AND DRIVE PLATE

### 1. INSPECT ONE-WAY CLUTCH

(a) Install SST into the inner race of the one-way clutch.  
SST 09350-30020 (09351-32010)

(b) Install SST so that it fits in the notch of the converter hub and outer race of the one-way clutch.  
SST 09350-30020 (09351-32020)

(c) With the torque converter clutch standing on its side, the clutch locks when turned counterclockwise, and rotates freely and smoothly clockwise. If necessary, clean the converter and retest the clutch. Replace the converter if the clutch still fails the test.

### 2. MEASURE DRIVE PLATE RUNOUT AND INSPECT RING GEAR

Set up a dial indicator and measure the drive plate runout.

If runout exceeds 0.20 mm (0.0079 in.) or if the ring gear is damaged, replace the drive plate. If installing a new drive plate, note the orientation of spacers and tighten the bolts.

**Torque: 83 N-m (850 kgf-cm, 61 ft-lbf)**

### 3. MEASURE TORQUE CONVERTER CLUTCH SLEEVE RUNOUT

(a) Temporarily mount the torque converter clutch to the drive plate. Set up a dial indicator.

If runout exceeds 0.30 mm (0.0118 in.), try to correct by reorienting the installation of the converter. If excessive runout cannot be corrected, replace the torque converter clutch.

**HINT:** Mark the position of the converter to ensure correct installation.

(b) Remove the torque converter clutch.

# A340H Automatic Transmission

# DESCRIPTION

## General

The A340H automatic transmission is a four-speed, Electronic Controlled Transmission with electronically controlled 4WD transfer, developed with the aim of producing an easy-driving 4WD vehicle.

The transfer section consists of planetary gears, hydraulic clutches and hydraulic brake. The operation of these is fully controlled by the ECM.

The A340H transmission is mainly composed of the torque converter clutch, the overdrive (hereafter called O/D) planetary gear unit, 3-speed planetary gear unit, 2-speed transfer, the hydraulic control system and the electronic control system.

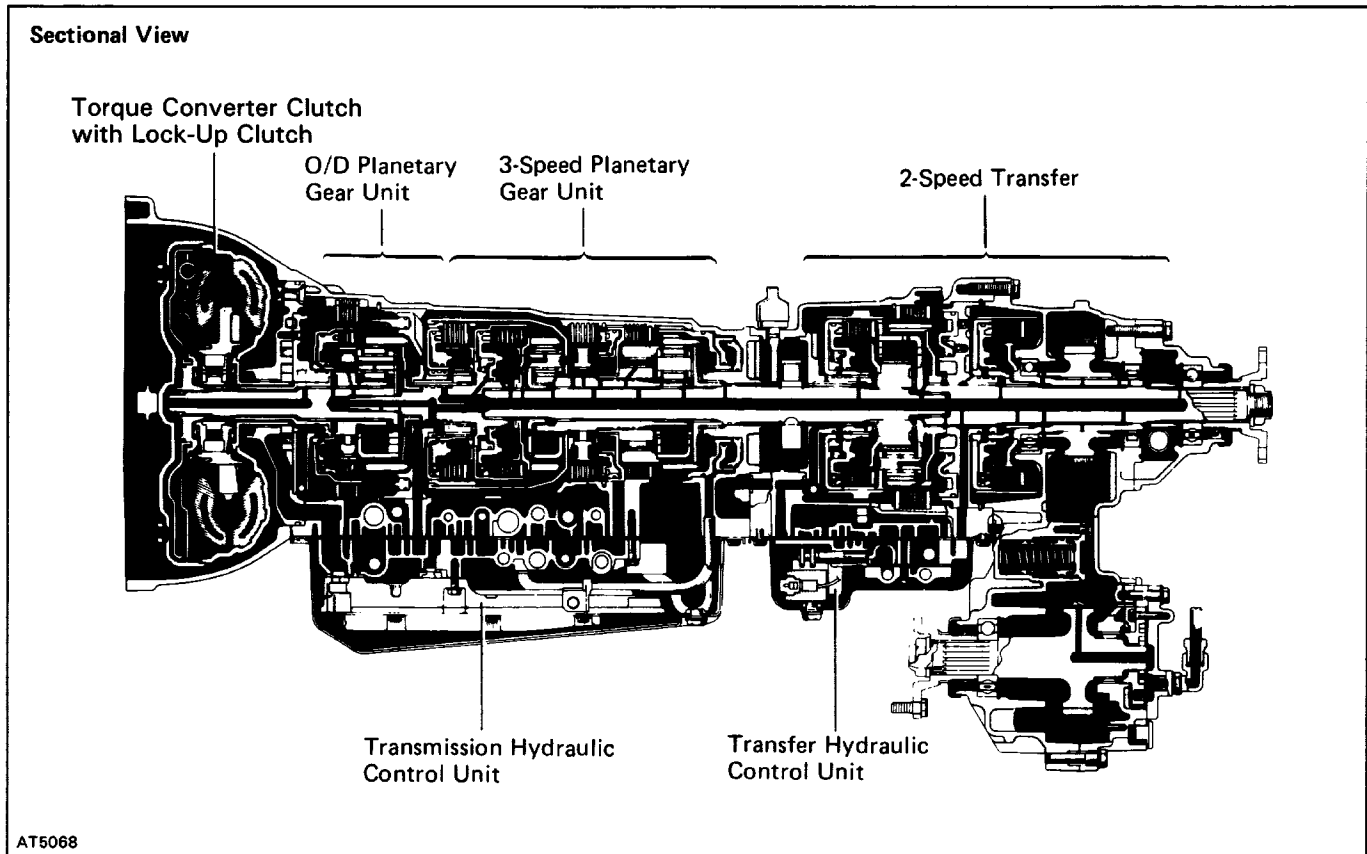

**General Specifications**

Type of Transmission			A340H
Type of Engine			3VZ-E
Torque Converter Clutch		Stall Torque Ratio	2.1 : 1
		Lock-Up Mechanism	Equipped
Gear Ratio	Transmission	1 st Gear	2.804
		2nd Gear	1.531
		3rd Gear	1.000
		O/D Gear	0.705
		Reverse Gear	2.393
	Transfer	High (H2, H4)	1.000
Low (L4)		2.659	
Number of Discs and Plates (Disc /Plate)	Transmission	C <sub>1</sub> Forward Clutch	5/5
		C <sub>2</sub> Direct Clutch	4/4
		C <sub>0</sub> O/D Direct Clutch	2/2
		B <sub>2</sub> 2nd Brake	5/5
		B <sub>3</sub> 1 st & Reverse Brake	6/6
		B <sub>0</sub> O/D Brake	4/3
	Transfer	C <sub>3</sub> Transfer Direct Clutch	6/6
		B <sub>4</sub> Low Speed Brake	7/6
ATF	Type		ATF DEXRON® II
	Capacity liter (US qts, Imp. qts)	Total	Transmission: 10.3 (10.9, 9.1), Transfer: 1.1 (1.2, 1.0)
		Drain & Refill	Transmission: 4.5 (4.8, 4.0), Transfer: 0.8 (0.8, 0.7)



# OPERATION

## Mechanical Operation

### OPERATING CONDITIONS

#### 1. Transmission

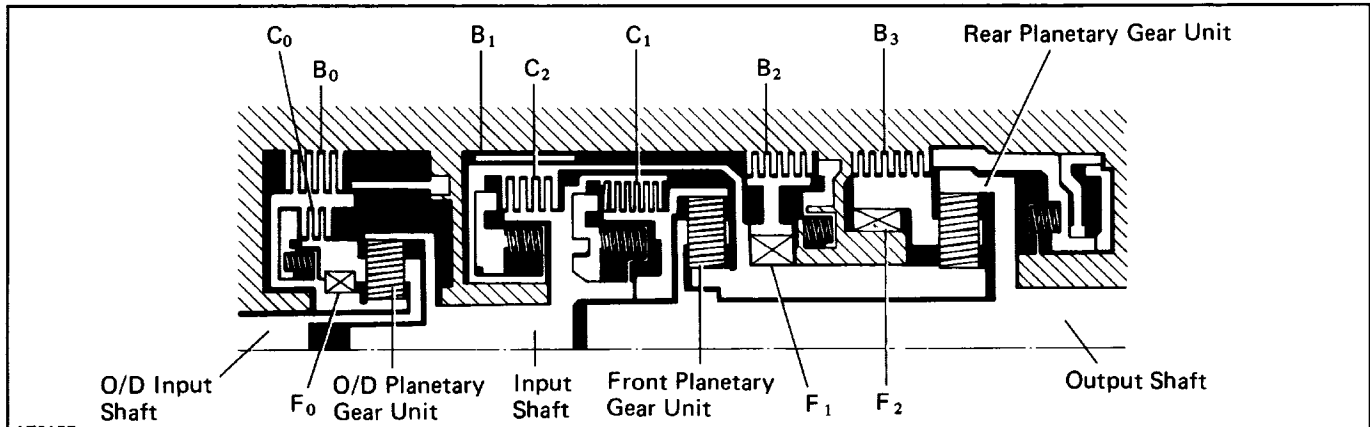

AT2157

Shift Level Position	Gear	No. 1 Solenoid Valve	No. 2 Solenoid Valve	C <sub>0</sub>	C <sub>1</sub>	C <sub>2</sub>	B <sub>0</sub>	B <sub>1</sub>	B <sub>2</sub>	B <sub>3</sub>		F <sub>0</sub>	F <sub>1</sub>	F <sub>2</sub>
										I.P.	O.P.			
P	Parking	ON	OFF	●										
R	Reverse	ON	OFF	●		●					●	●	●	
N	Neutral	ON	OFF	●										
D	1st	ON	OFF	●	●							●		●
	2nd	ON	ON	●	●				●			●	●	
	3rd	OFF	ON	●	●	●			●			●		
	O/D	OFF	OFF		●	●	●		●					
2	1st	ON	OFF	●	●							●		●
	2nd	ON	ON	●	●			●	●			●	●	
	3rd	OFF	ON	●	●	●			●			●		
L	1st	ON	OFF	●	●						●	●	●	●
	* 2nd	ON	ON	●	●			●	●			●	●	

\* Down-shift only in the L position and 2nd gear—no up-shift.

I.P. .... Inner Piston  
O.P. .... Outer Piston

#### 2. Transfer

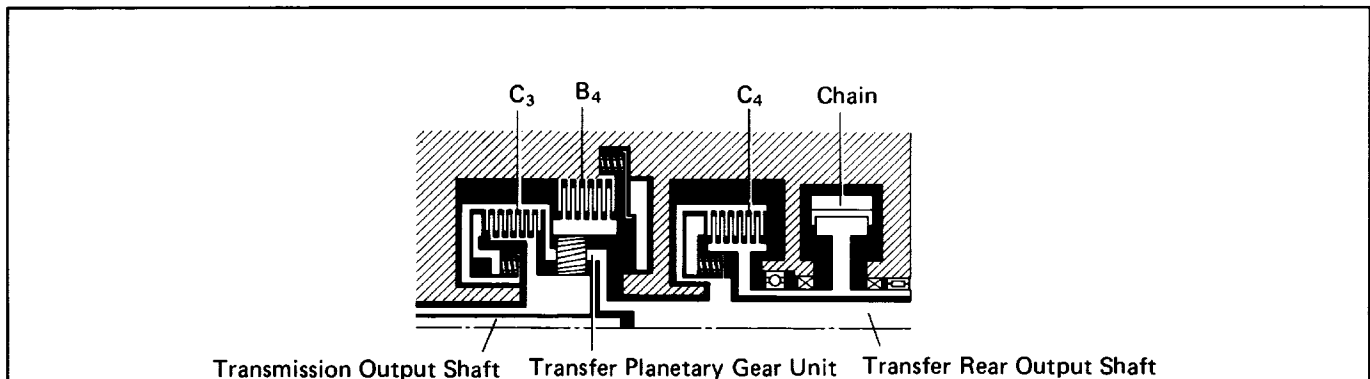

ND0045

Transfer gear position	No.4 solenoid valve	C <sub>3</sub>	C <sub>4</sub>	B <sub>4</sub>
H2	OFF	●		
H4	OFF	●	●	
L4	ON		●	●

# FUNCTION OF COMPONENTS

## 1. Transmission

Component		Function
C <sub>1</sub>	Forward Clutch	Connects input shaft and front planetary ring gear.
C <sub>2</sub>	Direct Clutch	Connects input shaft and front & rear planetary sun gear.
C <sub>0</sub>	O/D Direct Clutch	Connects overdrive sun gear and overdrive planetary carrier.
B <sub>1</sub>	2nd Coast Brake	Prevents front & rear planetary sun gear from turning either clockwise or counterclockwise.
B <sub>2</sub>	2nd Brake	Prevents outer race of F, from turning either clockwise or counterclockwise thus preventing the front & rear planetary sun gear from turning counterclockwise.
B <sub>3</sub>	1 st & Reverse Brake	Prevents rear planetary carrier from turning either clockwise or counterclockwise.
B <sub>0</sub>	O/D Brake	Prevents overdrive sun gear from turning either clockwise or counterclockwise.
F <sub>1</sub>	No. 1 One-Way Clutch	When B <sub>2</sub> is operating, this clutch prevents the front & rear planetary sun gear from turning counterclockwise.
F <sub>2</sub>	No.2 One-Way Clutch	Prevents rear planetary carrier from turning counterclockwise.
F <sub>0</sub>	O/D One-Way Clutch	When the transmission is being driven by the engine, this clutch connects the overdrive sun gear and overdrive planetary carrier.
Planetary Gears		These gears change the route through which driving force is transmitted in accordance with the operation of each clutch and brake in order to increase or reduce the input and output speed.

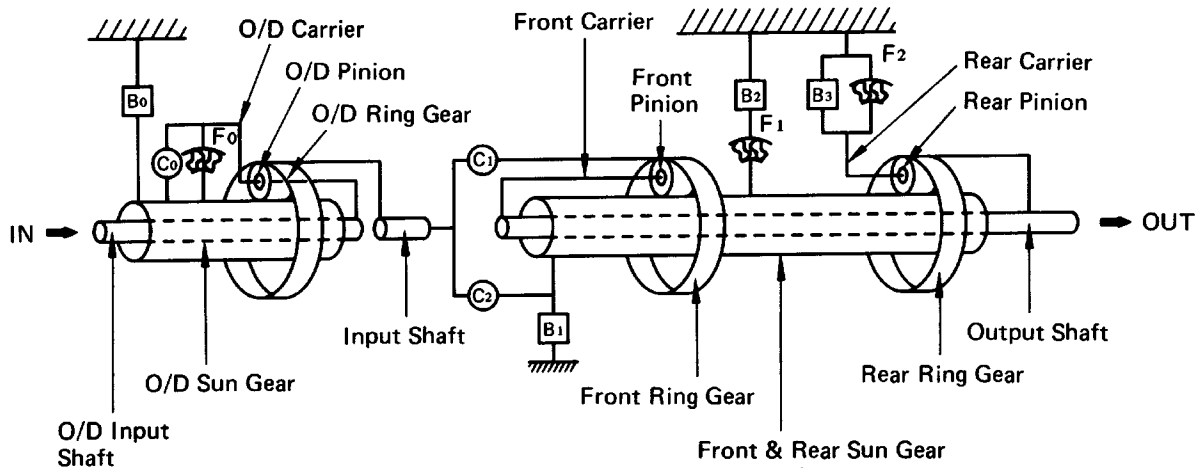

# FUNCTION OF COMPONENTS (Cont'd)

The conditions of operation for each gear position are shown in the following illustrations:

**D or 2 Position 1st Gear**

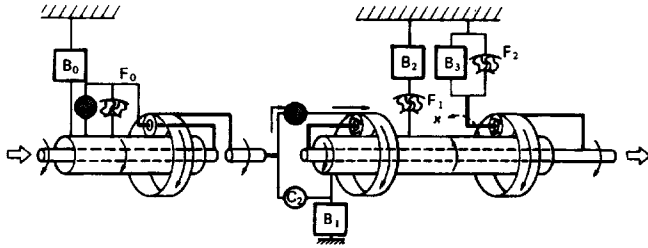

AT5854

**2 or L Position 2nd Gear**

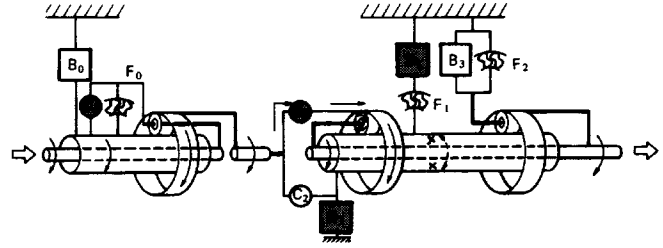

AT5854

**D Position 2nd Gear**

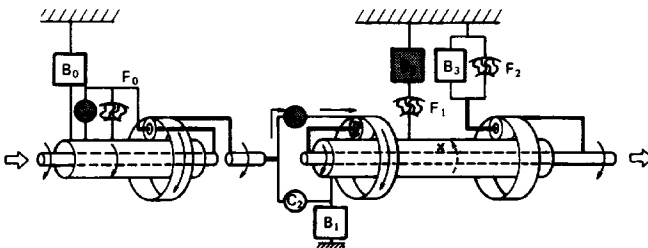

AT5854

**L Position 1st Gear**

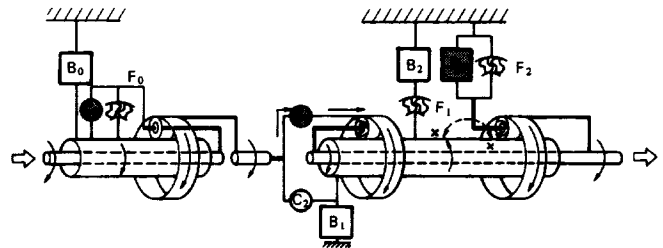

AT5854

**D or 2 Position 3rd Gear**

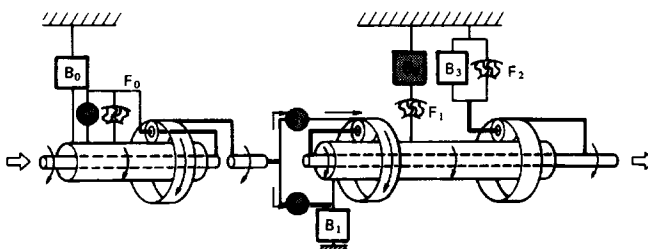

AT5854

**R Position Reverse Gear**

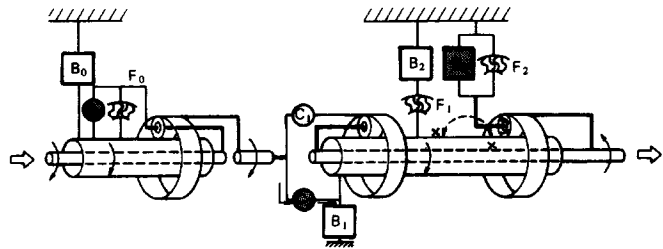

AT5854

**D Position O/D**

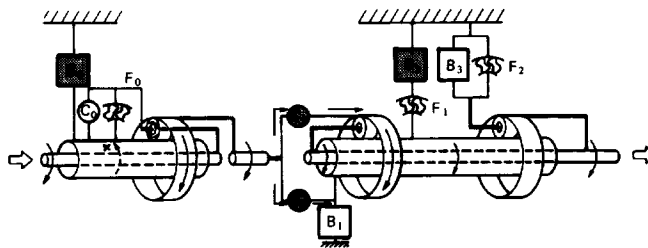

AT5854

# FUNCTION OF COMPONENTS (Cont'd)

## 2. Transfer

Component		Function
C <sub>3</sub>	Forward Clutch	Connects transmission output shaft and transfer pinion gear.
C <sub>4</sub>	Direct Clutch	Connects transfer rear output shaft and front drive gear.
B <sub>4</sub>	O/D Direct Clutch	Prevents transfer ring gear from turning either clockwise or counterclockwise.

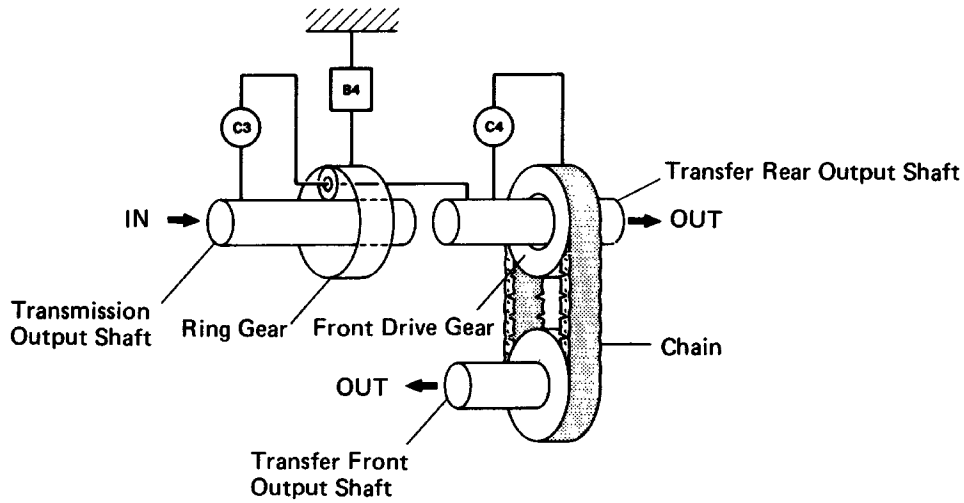

ND0047

The conditions of operation for each gear position are shown in the following illustrations:

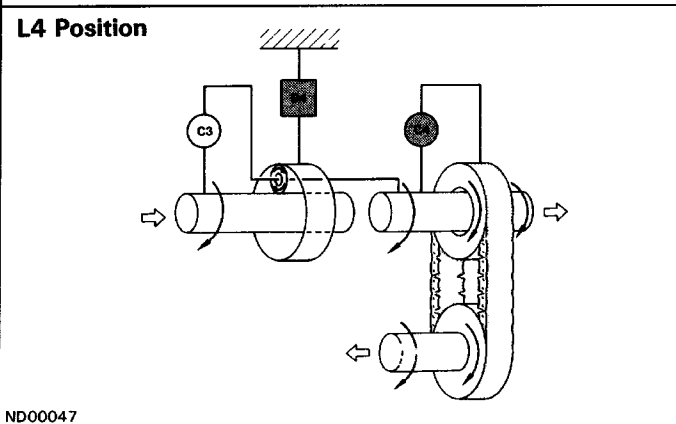
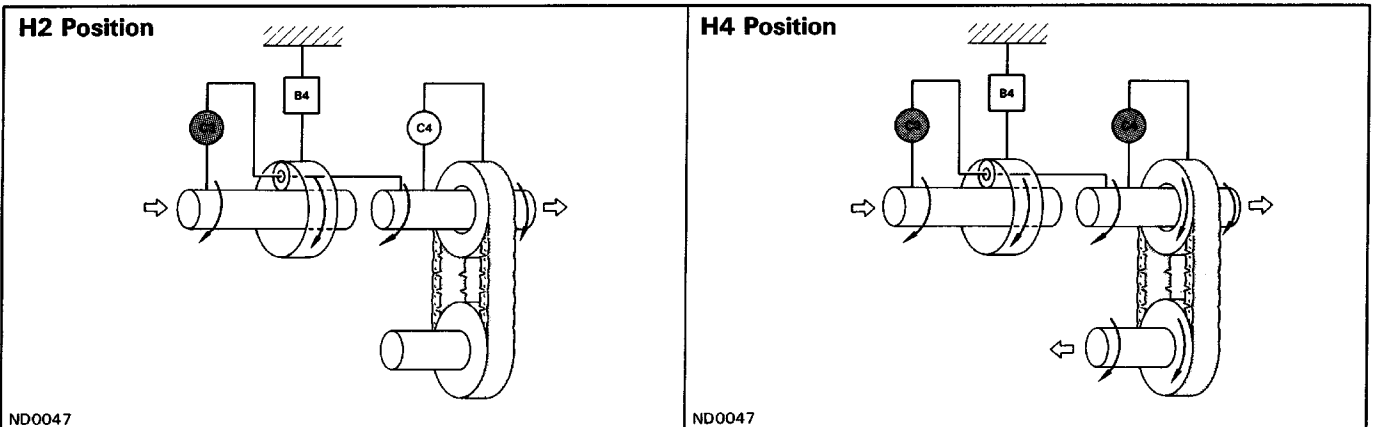

# Hydraulic Control System

## 1. Transmission

The hydraulic control system is composed of the oil pump, the valve body, the solenoid valves, and the clutches and brakes, as well as the fluid passages which connect all of these components. Based on the hydraulic pressure created by the oil pump, the hydraulic control system governs the hydraulic pressure acting on the torque converter clutch, clutches and brakes in accordance with the vehicle driving conditions. There are three solenoid valves on the valve body. These solenoid valves are turned on and off by signals from the ECM to operate the shift valves. These shift valves then switch the fluid passages so that fluid goes to the torque converter clutch and planetary gear units.

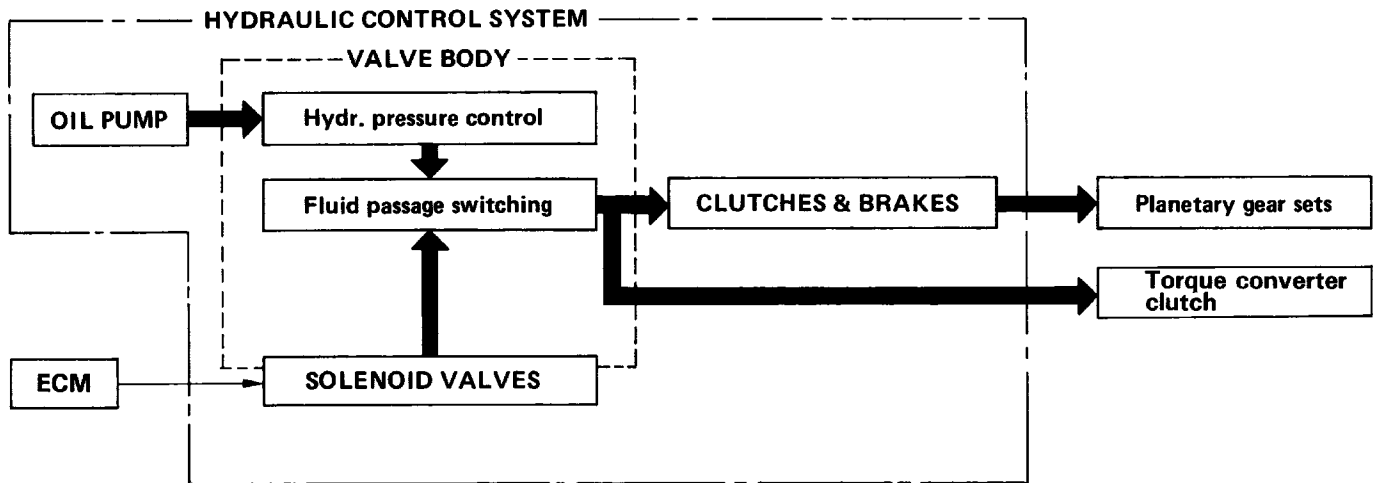

## 2 Transfer

The hydraulic control system consists of a valve body, No.4 solenoid valve, a brake (B<sub>4</sub>) and two clutches (C<sub>3</sub>, C<sub>4</sub>) and passages that connect these elements. It hydraulically controls the planetary gear unit either manually, or automatically by the ECM.

## Electronic Control System

The electronic control system, which controls the transmission and transfer shift timing and the operation of the lock-up clutch, is composed of the following three parts:

### 1. Sensors

These sensors sense the vehicle speed, throttle opening and other conditions and send these data to the ECM in the form of electrical signals.

### 2. ECM

The ECM determines the transmission and transfer shift timing and lock-up timing based upon the signals from sensors, and controls the solenoid valves of the hydraulic control unit accordingly.

### 3. Actuators

These are four solenoid valves that control hydraulic pressure acting on the hydraulic valves to control shifting and lock-up timing.

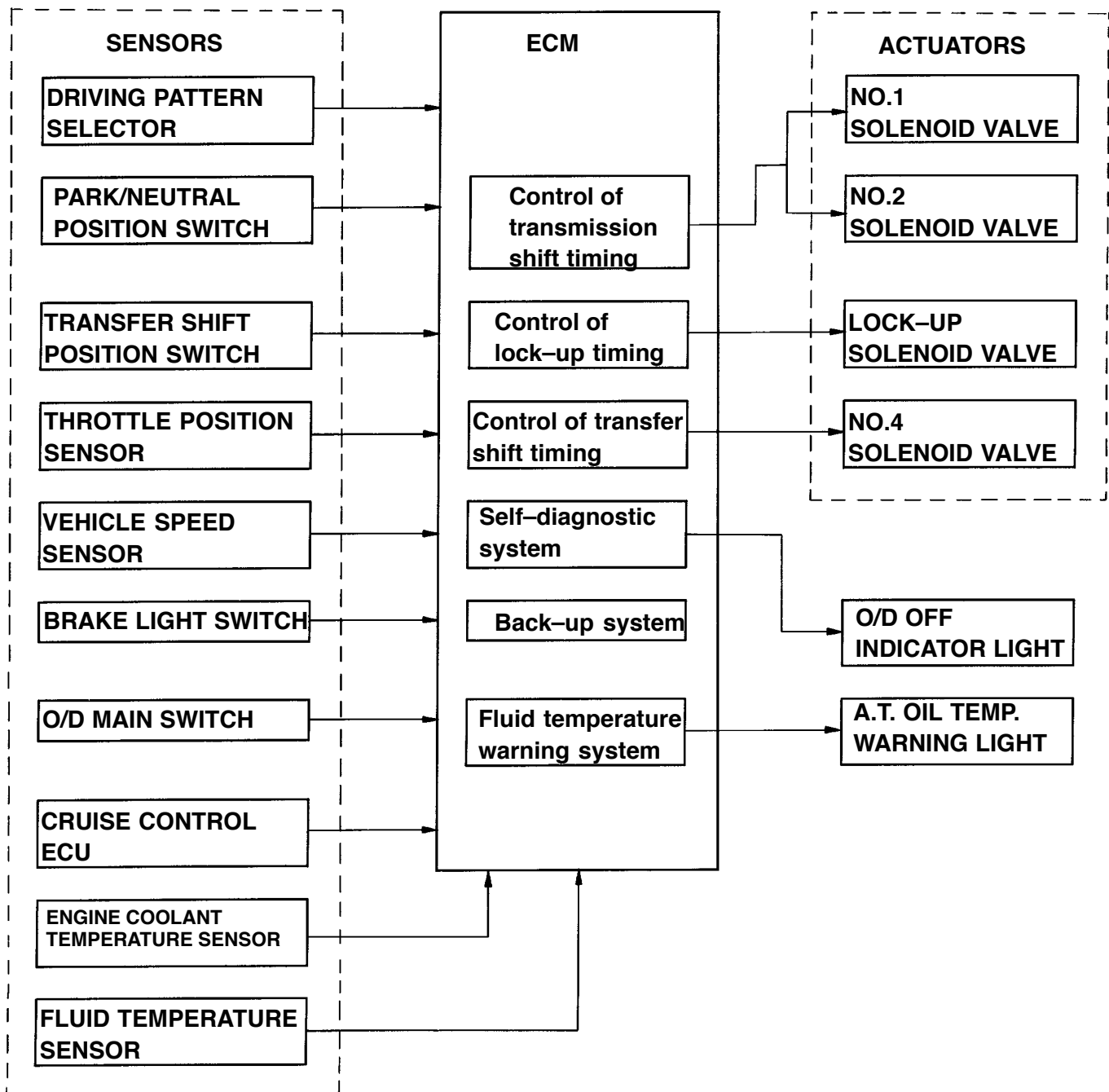

# TROUBLESHOOTING

## Basic Troubleshooting

Before troubleshooting an electronic controlled transmission first determine whether the problem is electrical or mechanical. To do this, just refer to the basic troubleshooting flow-chart provide below.

If the cause is already known, using the basic troubleshooting chart below along with the general troubleshooting chart on the following pages should speed the procedure.

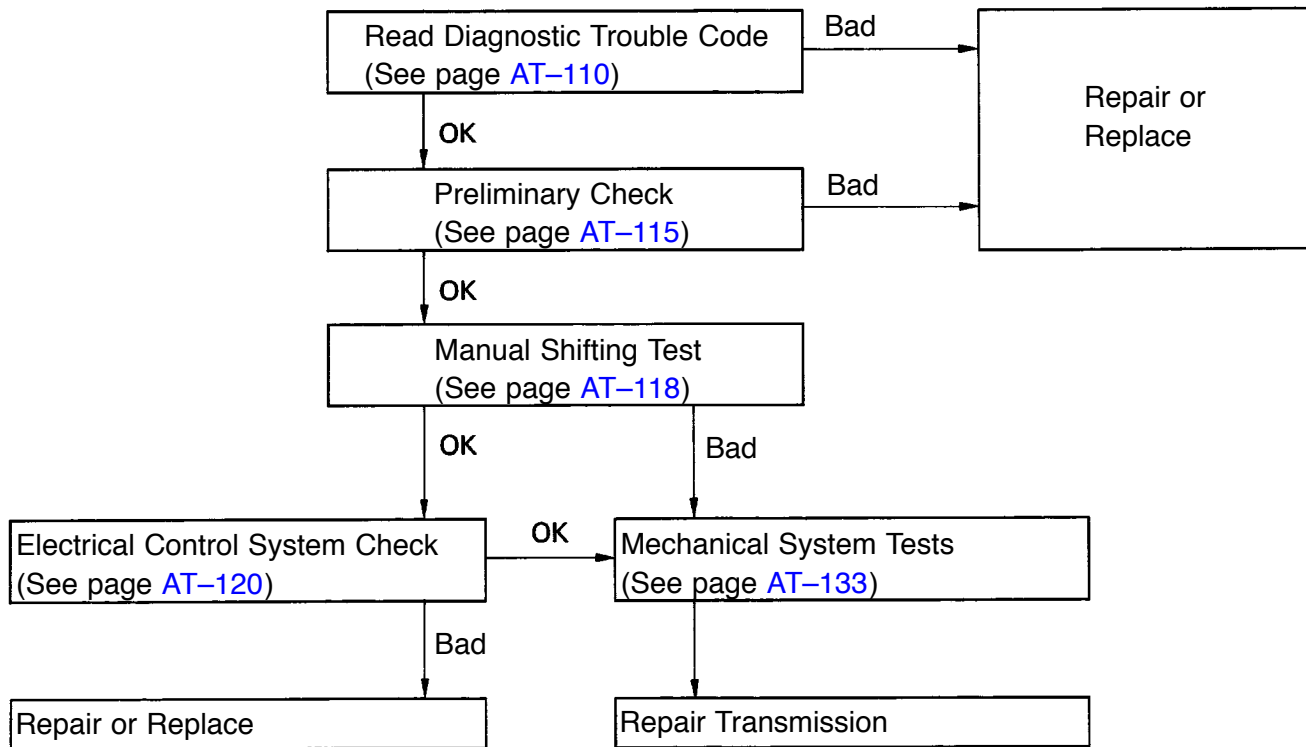

## General Troubleshooting

Problem	Possible cause	Remedy	Page
Fluid discolored or smells burnt	Fluid contaminated Torque converter clutch faulty Transmission faulty	Replace fluid Replace torque converter clutch Disassemble and inspect transmission	AT-115 AT-162 ©
Vehicle does not move in any forward position or reverse	Manual linkage out of adjustment Valve body or primary regulator faulty Parking lock pawl faulty Torque converter clutch faulty Converter drive plate broken Oil pump intake screen blocked Transmission faulty	Adjust linkage Inspect valve body Inspect parking lock pawl Replace torque converter clutch Replace drive plate Clean screen Disassemble and inspect transmission	AT-116 © AT-158 AT-162 AT-162 © ©
Shift lever position incorrect	Manual linkage out of adjustment Manual valve and lever faulty Transmission faulty	Adjust linkage Inspect valve body Disassemble and inspect transmission	AT-116 © ©
Harsh engagement into any drive position	Throttle cable out of adjustment Valve body or primary regulator faulty Accumulator pistons faulty Transmission faulty	Adjust throttle cable Inspect valve body Inspect accumulator pistons Disassemble and inspect transmission	AT-116 © © ©
Delayed 1-2, 2-3 or 3-0/1) up-shift, or down-shifts from O/D-3 or 3-2 and shifts back to O/D or 3	Electronic control faulty Valve body faulty Solenoid valve faulty	Inspect electronic control Inspect valve body Inspect solenoid valve	AT-120 © ©
Slips on 1-2, 2-3 or 3-0/D up-shift, or slips or shudders on acceleration	Manual linkage out of adjustment Throttle cable out of adjustment Valve body faulty Solenoid valve faulty Transmission faulty	Adjust linkage Adjust throttle cable Inspect valve body Inspect solenoid valve Disassemble and inspect transmission	AT-116 AT-116 © © ©
Drag, binding or tie-up on 1-2, 2-3 or 3-O/D up-shift	Manual linkage out of adjustment Valve body faulty Transmission faulty	Adjust linkage Inspect valve body Disassemble and inspect transmission	AT-116 © ©

Remark \*: Refer to A340H Automatic Transmission Repair Manual. (Pub. No. RM271U)



## General Troubleshooting (Cont'd)

Problem	Possible cause	Remedy	Page
No lock-up in 2nd, 3rd or O/D	Electronic control faulty Valve body faulty Solenoid valve faulty Transmission faulty	Inspect electronic control Inspect valve body Inspect solenoid valve Disassemble and inspect transmission	AT-120 © © ©
Harsh down-shift	Throttle cable out of adjustment Throttle cable and cam faulty Accumulator pistons faulty Valve body faulty Transmission faulty	Adjust throttle cable Inspect throttle cable and cam Inspect accumulator pistons Inspect valve body Disassemble and inspect transmission	AT-116 AT-116 © © ©
No down-shift when coasting	Valve body faulty Solenoid valve faulty Electronic control faulty	Inspect valve body Inspect solenoid valve Inspect electronic control	© © AT-120
Down-shift occurs too quickly or too late while coasting	Throttle cable faulty Valve body faulty Transmission faulty  Solenoid valve faulty Electronic control faulty	Inspect throttle cable Inspect valve body Disassemble and inspect transmission Inspect solenoid valve Inspect electronic control	AT-116 © © © AT-120
No O/D-3, 3-2 or 2-1 kick-down	Solenoid valve faulty Electronic control faulty Valve body faulty	Inspect solenoid valve Inspect electronic control Inspect valve body	© AT-120 ©
No engine braking in 2 or L position	Solenoid valve faulty Electronic control faulty Valve body faulty Transmission faulty	Inspect solenoid valve Inspect electronic control Inspect valve body Disassemble and inspect transmission	© AT-120 © ©
Vehicle does not hold in P	Manual linkage out of adjustment Parking lock pawl cam and spring faulty	Adjust linkage Inspect cam and spring	AT-116 AT-158
No H2-H4, H4-L4, L4-H4 or H4-H2 change gear position of transfer	Transfer linkage out of adjustment Electronic control faulty Transfer valve body faulty Transfer faulty	Adjust linkage Inspect electronic control Inspect valve body Disassemble and inspect transfer	AT-116 AT-120 © ©

Remark \*: Refer to A340H Automatic Transmission Repair Manual. (Pub. No. RM271 U)

# Diagnosis System

## DESCRIPTION

1. A self-diagnosis function is built into the electrical control system. Warning is indicated by the overdrive OFF indicator light.

HINT: Warning and diagnostic trouble codes can be read only when the overdrive switch is ON. If OFF, the overdrive OFF light is lit continuously and will not blink.

(a) If a malfunction occurs within the vehicle speed sensors (No. 1 or 2) or solenoids (No. 1, 2, or 4), the overdrive OFF light will blink to warn the driver.

However, there will be no warning of a malfunction with lock-up solenoid.

(b) The diagnostic trouble code can be read by the number of blinks of the overdrive OFF indicator light when terminals TE, and EI are connected.

(See page AT-111)

(c) The throttle position sensor or brake signal are not indicated, but inspection can be made by checking the voltage at terminal TT of the data link connector 1.

(d) The signals to each gear can be checked by measuring the voltage at terminal TT while driving.

2. The diagnostic trouble code is retained memory by the ECM and due to back-up voltage, is not canceled out when the engine is turned off. Consequently, after repair, it is necessary to turn the ignition switch off and remove the MFI fuse (1 5A) or disconnect the ECM connector to cancel out the diagnostic trouble code.

(See page AT-119)

HINT:

Low battery positive voltage will cause faulty operation of the diagnosis system. Therefore, always check the battery first.

Use a voltmeter and ohmmeter that have an impedance of at least 10 kΩ/v.

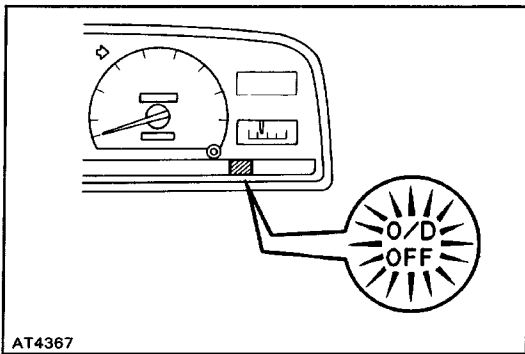

AT4367

### Diagnostic Trouble Code Output

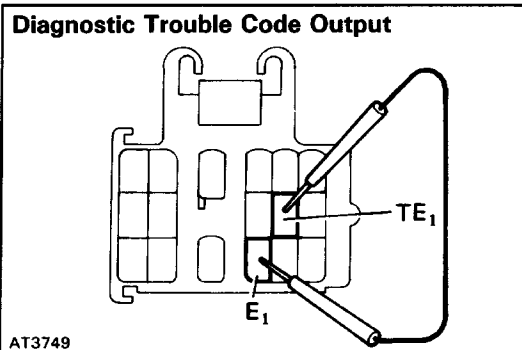

AT3749

### Voltage Check

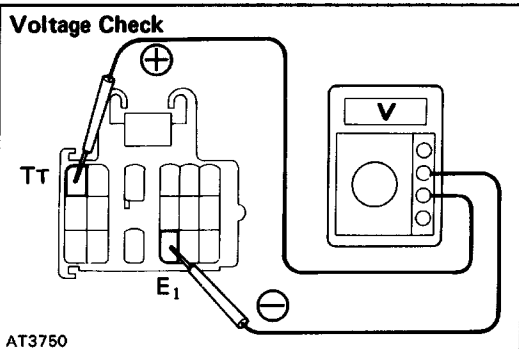

AT3750

### ECM

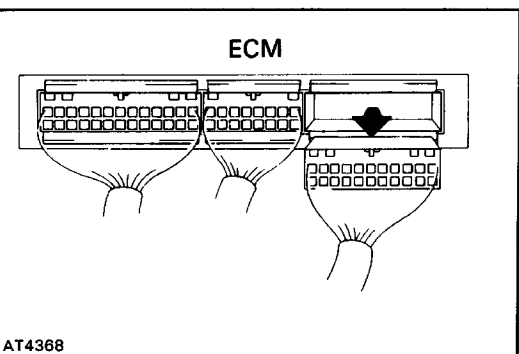

AT4368

### O/D Switch O/D OFF Light

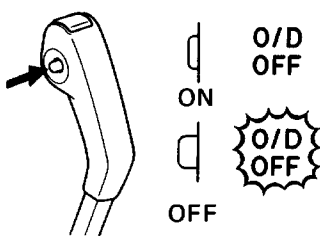

AT4488

### CHECK "O/D OFF" INDICATOR LIGHT

1. Turn the ignition switch ON.
2. The "O/D OFF" light will come on when the O/D switch is placed at OFF.
3. When the O/D switch is set to ON, the "O/D OFF" light should go out.

If the "O/D OFF" light flashes when the O/D switch is set to ON, the electronic control system is faulty.

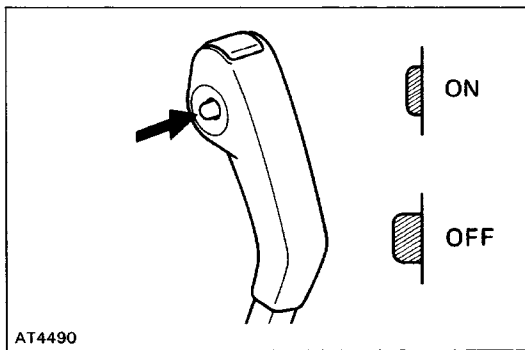

## READ DIAGNOSTIC TROUBLE CODE

### 1. TURN IGNITION SWITCH AND O/D SWITCH TO ON

Do not start the engine.

HINT: Warning and diagnostic trouble codes can be read only when the overdrive switch is ON. If OFF, the overdrive OFF light will light continuously and will not blink.

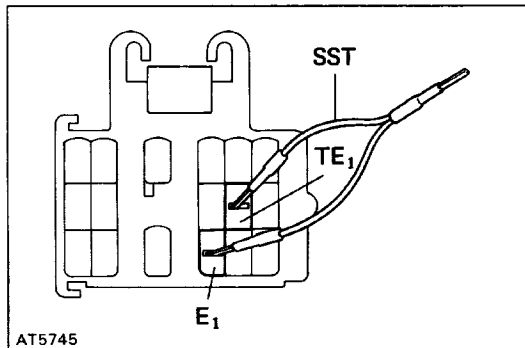

### 2. CONNECT TE, AND E, TERMINALS OF DATA LINK CONNECTOR 1

Using SST, connect terminals TE, and EI.  
SST 09843-18020

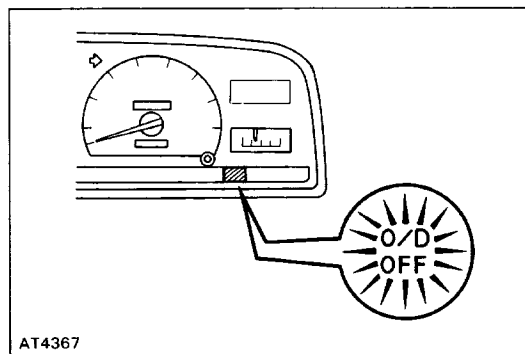

### 3. READ DIAGNOSTIC TROUBLE CODE

Read the diagnostic trouble code as indicated by the number of times the O/D OFF light flashes.

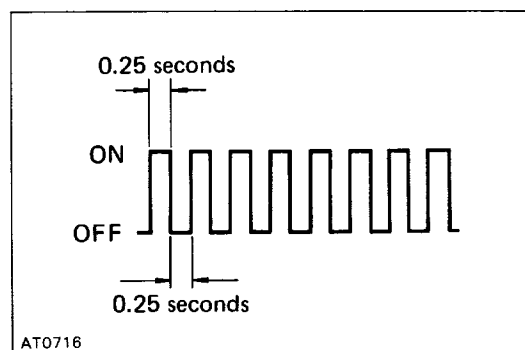

#### (Diagnostic Trouble Code Indication)

- If the system is operating normally, the light will flash 2 times per second.

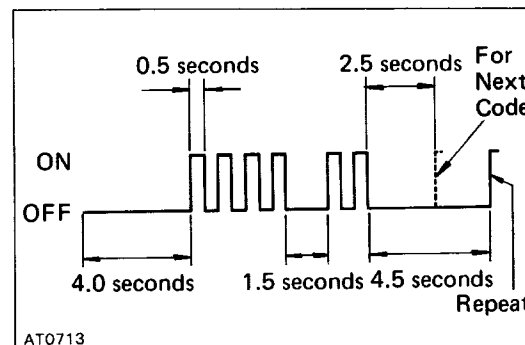







- In the event of a malfunction, the light will flash 1 time per second. The number of blinks will equal the first number and, after 1.5 seconds pause, the second number of the two digit diagnostic trouble code. If there are two or more codes, there will be a 2.5 seconds pause between each.

HINT: In the event of several trouble codes occurring simultaneously, indication will begin from the smaller value and continue to the larger.

### 4. REMOVE SST

## DIAGNOSTIC TROUBLE CODES

Code No.	Light Pattern	Diagnosis System
—		Normal
42		Defective No. 1 vehicle speed sensor (in ATM)—severed wire harness or short circuit
61		Defective No.2 vehicle speed sensor (in ATM)—severed wire harness or short circuit
62		Severed No. 1 solenoid or short circuit—severed wire harness or short circuit
63		Severed No.2 solenoid or short circuit—severed wire harness or short circuit
64		Severed lock-up solenoid or short circuit—severed wire harness or short circuit
65		Severed No.4 solenoid or short circuit—severed wire harness or short circuit

HINT: If codes 62, 63, 64 or 65 appear, there is an electrical malfunction in the solenoid.

Causes due to mechanical failure, such as a stuck valve, will not appear.

### CANCEL OUT DIAGNOSTIC TROUBLE CODE

- After repair of the trouble area, the diagnostic trouble code retained in memory by the ECM must be canceled by removing the MFI fuse (1 5A) for 10 seconds or more, depending on ambient temperature (the lower the temperature, the longer the fuse must be left out) with the ignition switch OFF.

HINT:

- Cancellation can be also done by removing the battery negative (-) terminal, but in this case other memory systems will be also canceled out.
  - The diagnostic trouble code can be also canceled out by disconnecting the ECM connector.
  - If the diagnostic trouble code is not canceled out, it will be retained by the ECM and appear along with a new code in event of future trouble.
- After cancellation, perform a road test to confirm that a "normal code" is now read on the O/D OFF light.

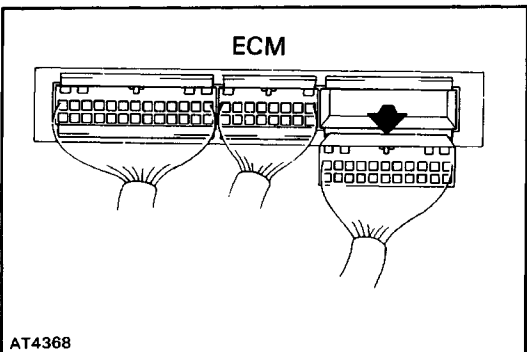
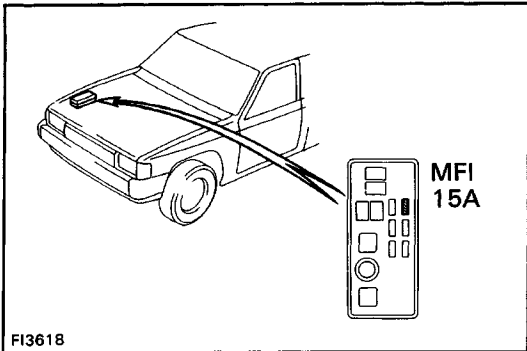

## TROUBLESHOOTING FLOW-CHART

### HINT:

- If diagnostic trouble code Nos. 42, 61, 62, 63 or 65 are output, the overdrive OFF indicator light will begin to blink immediately to warn the driver. However, an impact or shock may cause the blinking to stop; but the code will still be retained in the ECM memory unit canceled out.
  - There is no warning for diagnostic trouble code No. 64.
  - In the event of a simultaneous malfunction of both No. 1 and No. 2 vehicle speed sensors, no diagnostic trouble code will appear and the fail-safe system will not function. However, when driving in the D position, the transmission will not up-shift from first gear, regardless of the vehicle speed.
- Diagnostic trouble code 42 (No. 1 vehicle speed sensor circuitry)

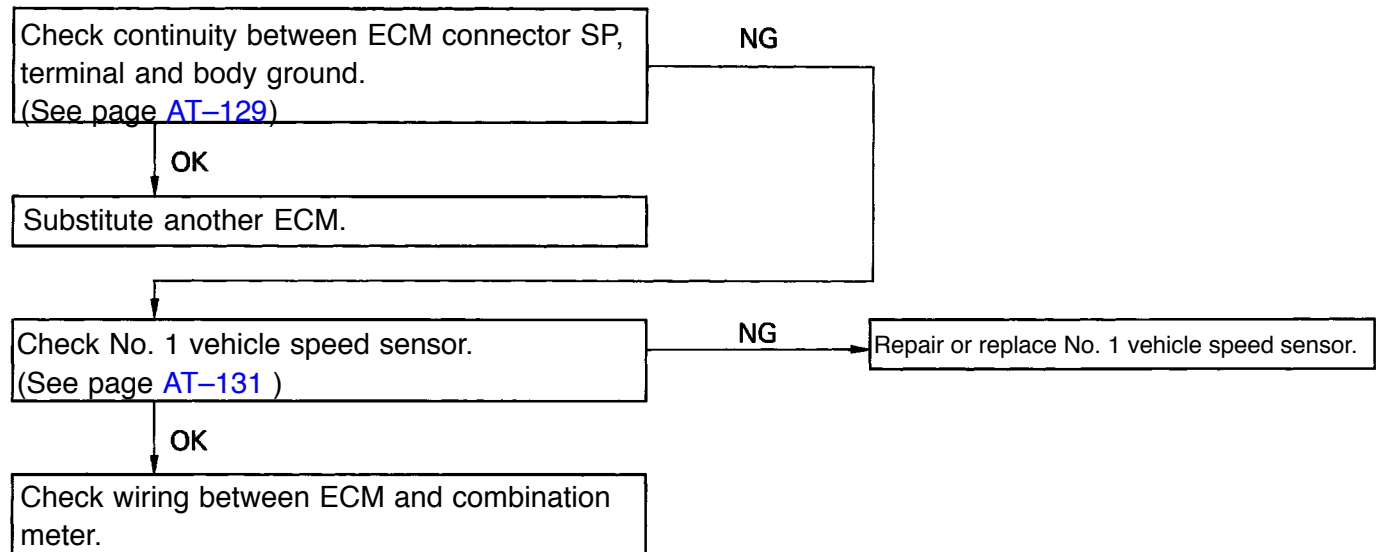

### Diagnostic trouble code 61 (No.2 vehicle speed sensor circuitry)

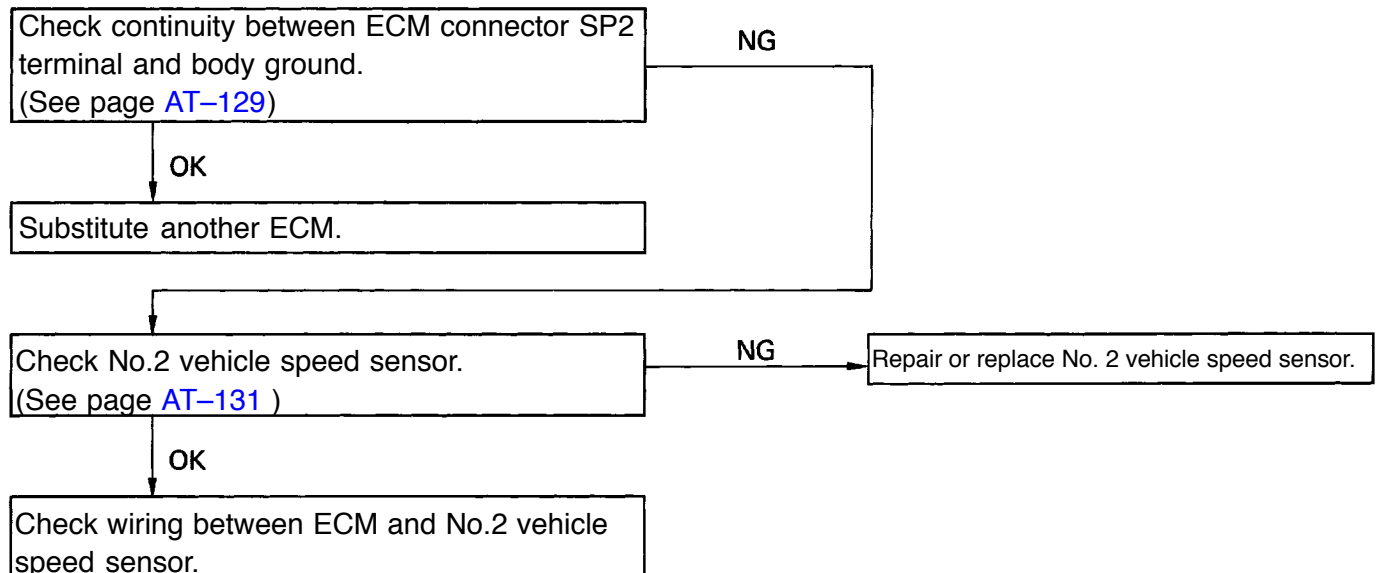

**Diagnostic trouble code 62 (No. 1 solenoid valve circuitry)**

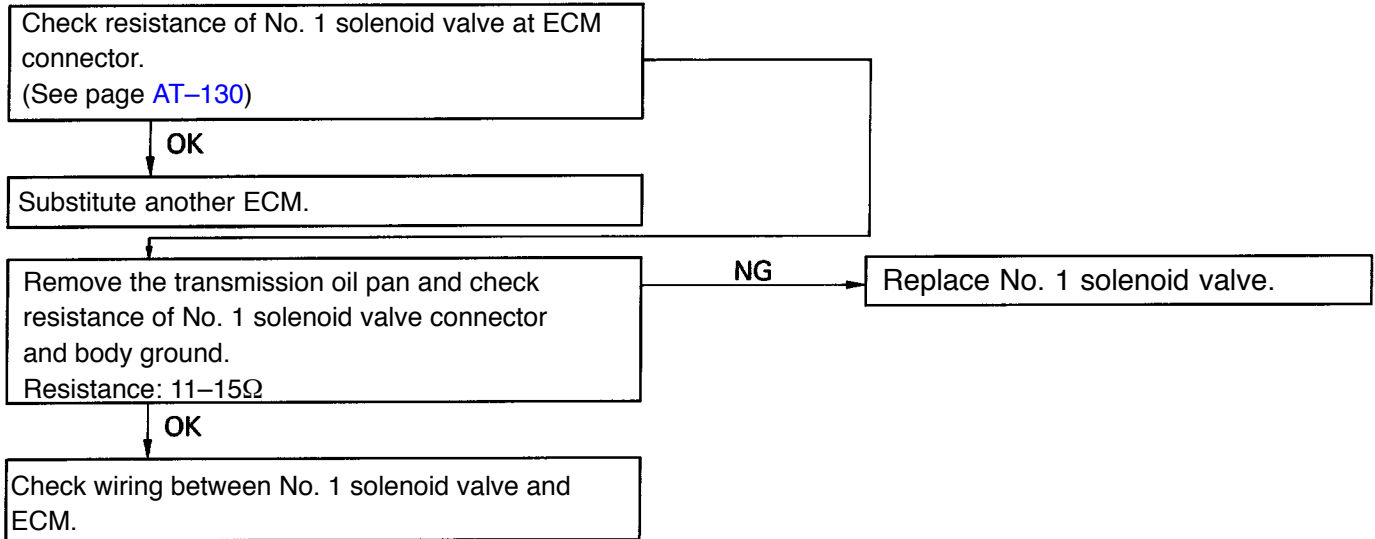

**Diagnostic trouble code 63 (No.2 solenoid valve circuitry)**

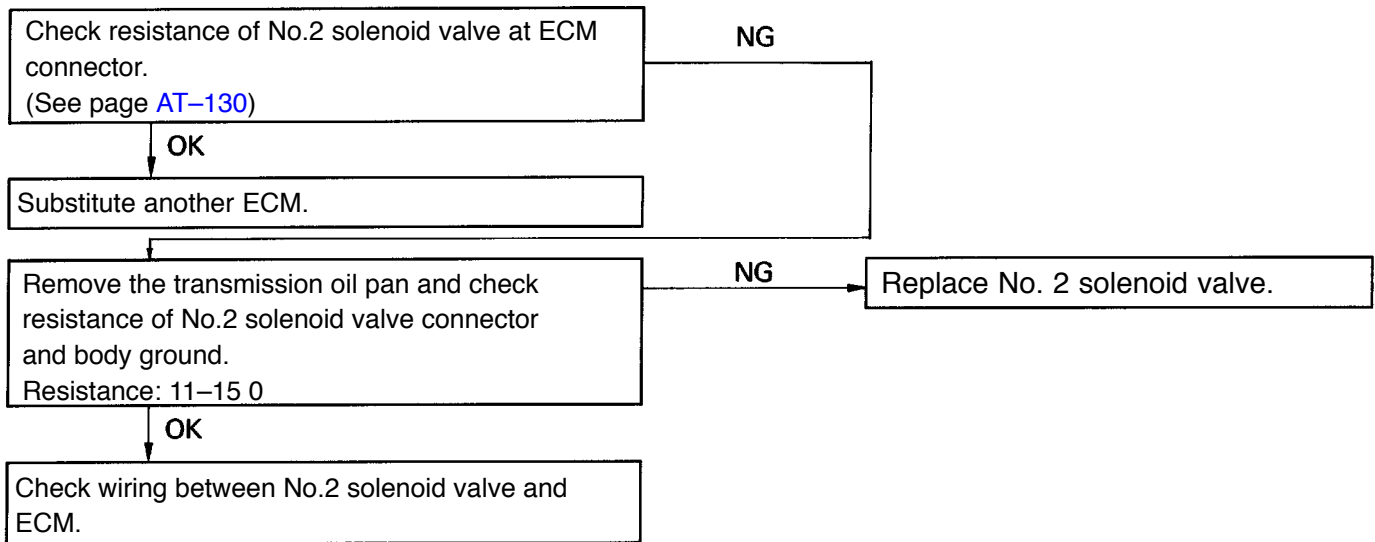

**Diagnostic trouble code 64 (Lock-up solenoid valve circuitry)**

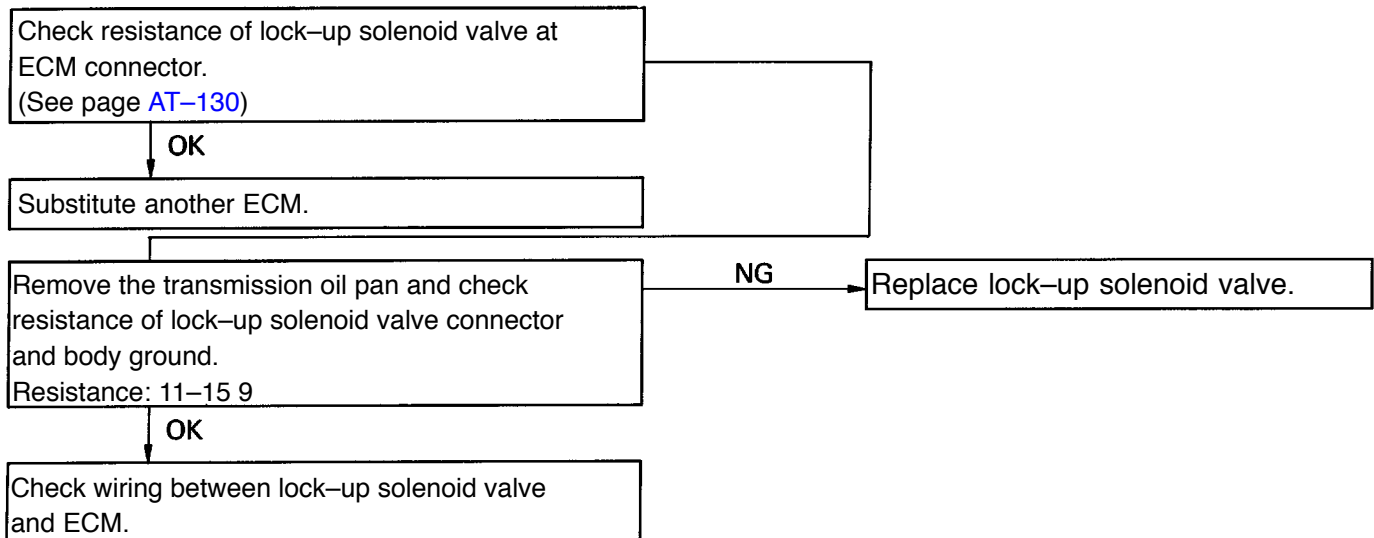

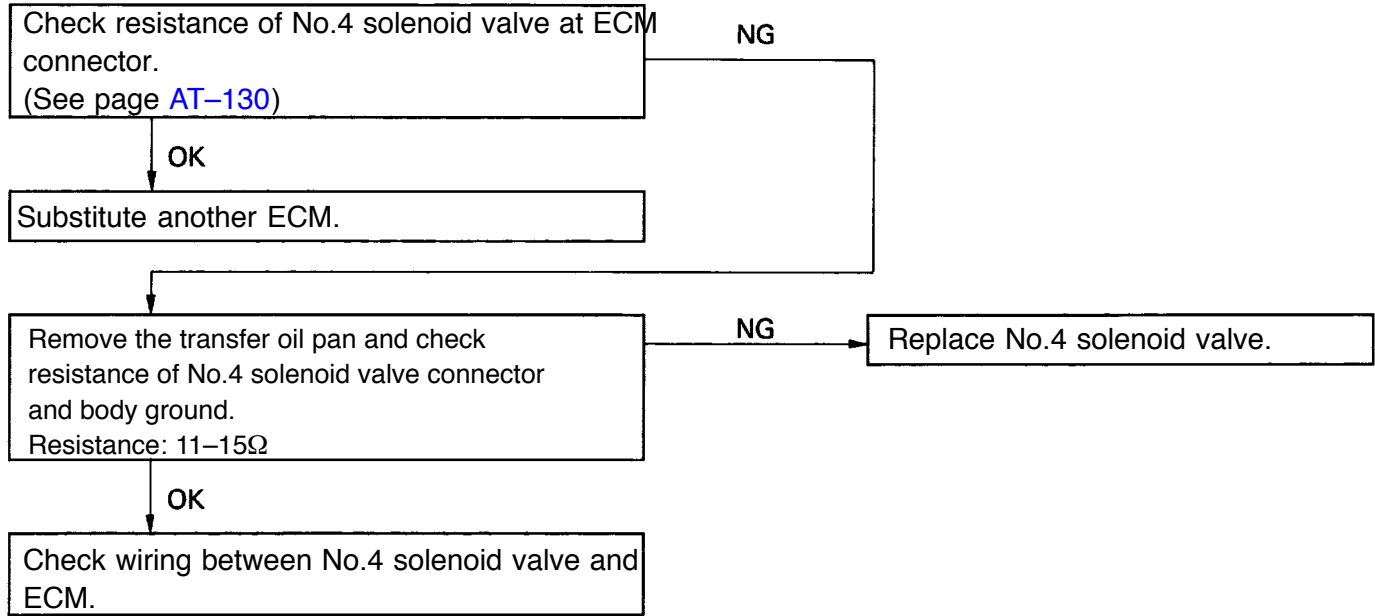
**Diagnostic trouble code 65 (No.4 solenoid valve circuitry)**

# Preliminary Check

## 1. CHECK FLUID LEVEL

(Transmission and transfer case)

HINT:

- The vehicle must have been driven so that the engine and transmission are at normal operating temperature. (Fluid temperature: 70–80°C or 158–176°F)
- Only use the COOL range on the dipstick as a rough reference when the fluid is replaced or the engine does not run.

- Park the vehicle on a level surface, set the parking brake.
- With the engine idling, shift the shift lever into all positions from P to L position and return to P position.
- Pull out the transmission dipstick and wipe it clean.
- Push it back fully into the tube.
- Pull it out and check that the fluid level is in the HOT range.

If the level is at the low side, add fluid.

**Fluid type: ATF DEXRON® II**

**NOTICE: Do not overfill.**

(Transfer chain case)

Remove the filler plug and feel inside the hole with your finger. Check that the oil comes to within 10 mm (0.39 in.) of the bottom edge of the hole.

If the level is low, add fluid until it begins to run out of the filler hole.

**Fluid type: ATF DEXRON® II**

## 2. CHECK FLUID CONDITION

If the fluid smells burnt or is black, replace it as following procedures.

(Transmission and transfer case)

- Remove the drain plugs and drain the fluid.
- Reinstall the drain plugs securely.
- With the engine OFF, add new fluid through the oil filler tube.

**Fluid type: ATF DEXRON® II**

**Capacity:** liter (US qts, Imp. qts)

	Transmission	Transfer
Drain and refill	4.5 (4.8, 4.0)	
	<small>*3.8 (4.0, 3)</small>	*1.2 (1.3, 1.1)
Total	10.3 (10.9, 9.1)	

\*: Reference capacity when replacing transmission or transfer valve body.

- Start the engine and shift the shift lever into all positions from P to L position and then shift into P position.

- With the engine idling, check the fluid level. Add fluid up to the COOL level on the dipstick.

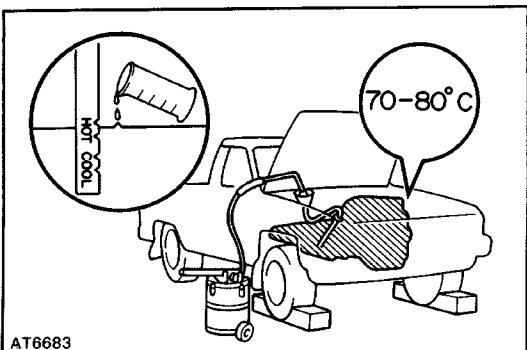
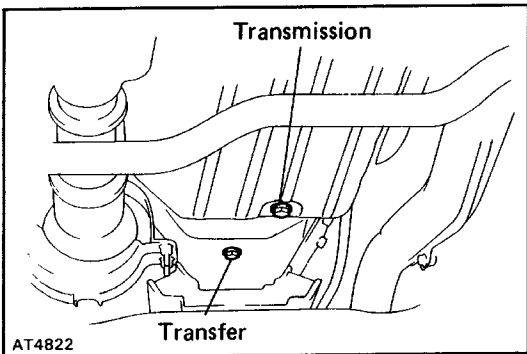
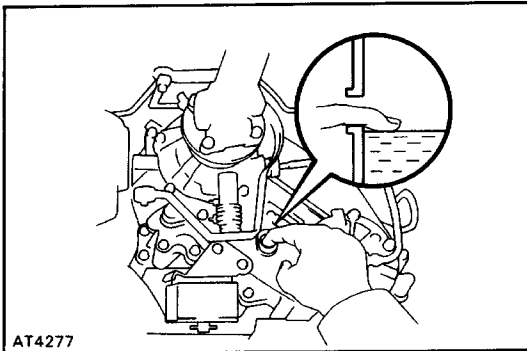
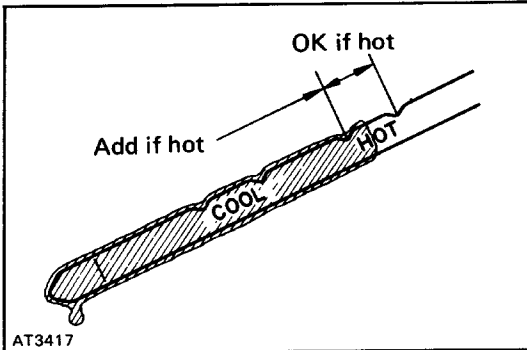



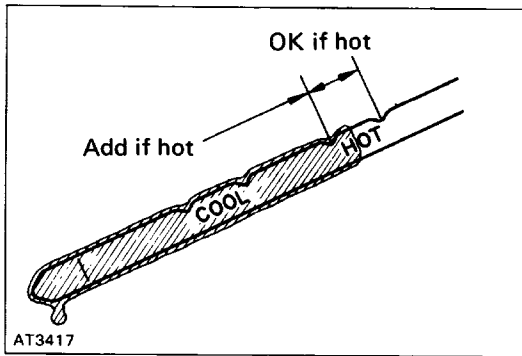

- (f) Check the fluid level with the normal operating temperature (70–80°C or 158–176°F) and add as necessary.

**NOTICE: Do not overfill.**

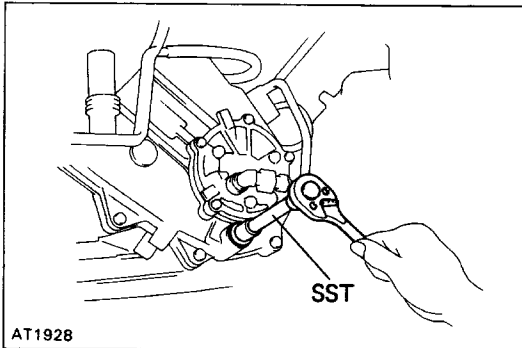

**(Transfer chain case)**

- Remove the transfer under cover.
- Remove the drain plug with SST and drain the fluid.  
SST 09043-38 100
- Reinstall the drain plug securely with SST.
- With the engine OFF, add new fluid through the filler hole.

**Fluid type: ATF DEXRON® II**

**Capacity:**

**Total**                    **1.1 liters**  
   **(1.2 US qts, 1.0 Imp. qts)**

**Drain and refill 0.8 liters**  
   **(0.8 US qts, 0.7 Imp. qts)**

- Check the fluid level.
- Install the transfer under cover.

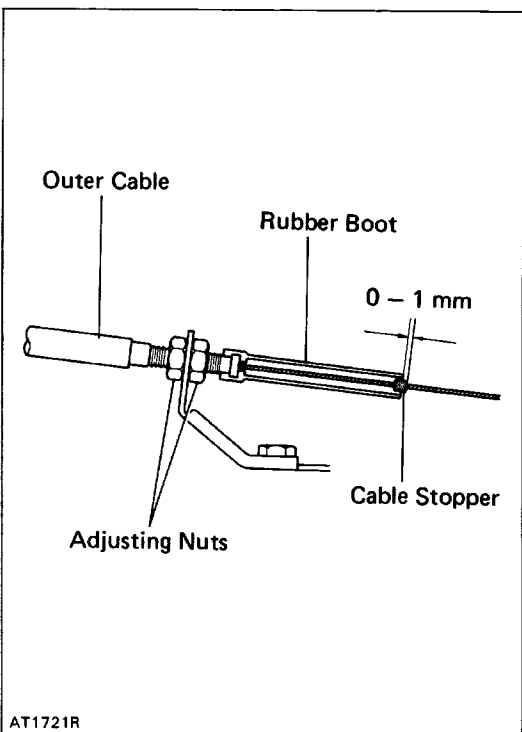
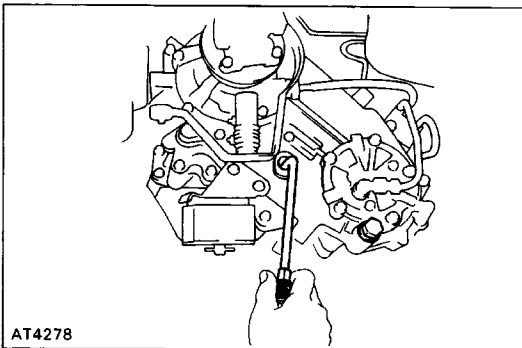

**3. INSPECT THROTTLE CABLE**

- Depress the accelerator pedal all the way and check that the throttle valve opens fully.

**HINT:** If the valve does not open fully, adjust the accelerator cable.

- Fully depress the accelerator pedal.
- Measure the distance between the end of the boot and stopper on the cable.

**Standard distance: 0–1 mm (0–0.04 in.)**

If the distance is not standard, adjust the cable by the adjusting nuts.

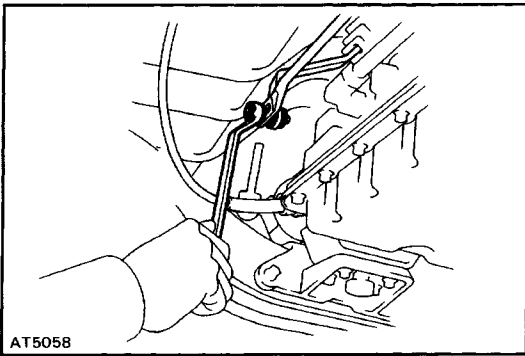

#### 4. INSPECT TRANSMISSION SHIFT LEVER POSITION

When shifting the shift lever from the IV position to other positions, check that the lever can be shifted smoothly and accurately to each position and that the position indicator correctly indicates the position.

If the indicator is not aligned with the correct position, carry out the following adjustment procedures.

- (a) Loosen the nut on the transmission control rod.
- (b) Push the control shaft lever fully rearward.
- (c) Return the control shaft lever two notches to N position.
- (d) Set the shift lever to N position.
- (e) While holding the shift lever lightly toward the R position side, tighten the nut.
- (f) Start the engine and make sure that the vehicle moves forward when shifting the lever from the N to D position and reverse when shifting it to the R position.

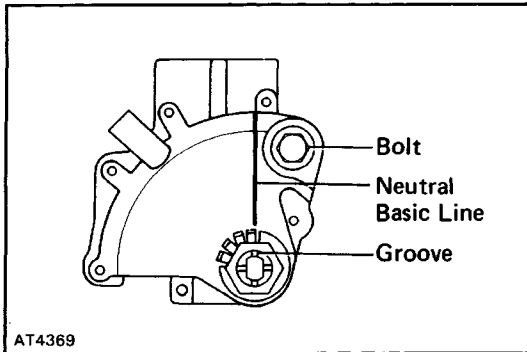

#### 5. INSPECT PARK/ NEUTRAL POSITION SWITCH

Check that the engine can be started with the shift lever only in the N or P position, but not in other positions.

If not as stated above, carry out the following adjustment procedures.

- (a) Loosen the park/neutral position switch bolt and set the shift lever to the N position.
- (b) Align the groove and neutral basic line.
- (c) Hold in position and tighten the bolt.

**Torque: 13 N·m (130 kgf·cm, 9 ft·lbf)**

#### 6. INSPECT TRANSFER SHIFT LEVER POSITION

When shifting the shift lever from H2 position to H4 and L4 positions, check that the lever can be shifted smoothly and accurately to each position and that the position indicator correctly indicates the position.

If the indicator is not aligned with the correct position, carry out the following adjustment procedures.

- (a) Loosen the nut on the cross shaft.
- (b) Push the control shaft lever fully forward.
- (c) Return the control shaft lever one notch to H4 position.
- (d) Set the shift lever H4 position.
- (e) While holding the shift lever lightly toward the L4 position side, tighten the nut.

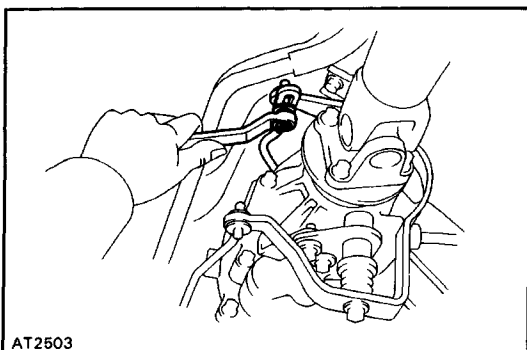

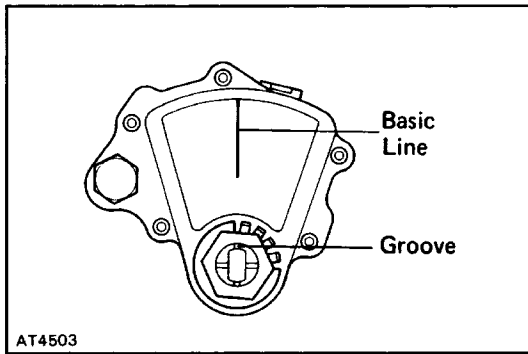

**7. INSPECT TRANSFER POSITION SWITCH**

If necessary, carry out the following adjustment procedures.

- (a) Loosen the transfer position switch bolt and set the transfer shift lever to the H4 position.
- (b) Align the groove and H4 basic line.
- (c) Hold in position and tighten the bolt.

**Torque: 13 N. m (130 kgf.cm, 9 ft. lbf)**

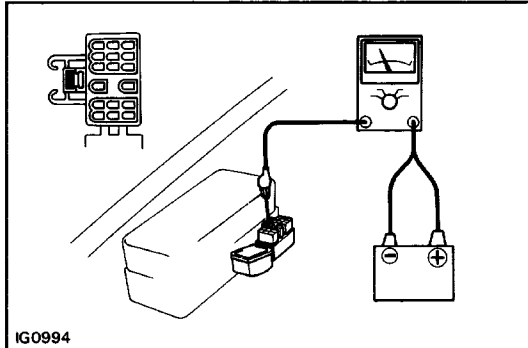

**8. INSPECT IDLE SPEED (N POSITION)**

Connect a tachometer test probe to the data link connector 1 terminal IG (3, inspect the idle speed.

Idle speed: 800 RPM

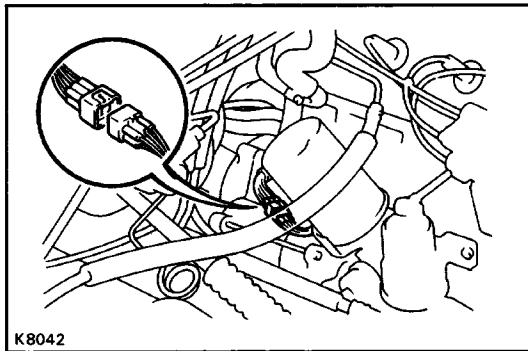

**Manual Shifting Test**

HINT: With this test, it can be determined whether the trouble lies within the electrical circuit or is a mechanical problem in the transmission.

- 1. DISCONNECT SOLENOID WIRE**
- 2. INSPECT MANUAL DRIVING OPERATION**

Check that the shift and gear positions correspond with the table below.

Shift position	Transmission					Transfer (Reference)		
	D position	2 position	L position	R position	P position	H2 position	H4 position	L4 position
Gear position	O/D	3rd	1 st	Reverse	Pawl Lock	High Gear 2W D	High Gear 4WD	High Gear 4WD

HINT: If the L, 2 and D position gear positions are difficult to distinguish, perform the following road test.

- While driving, shift through the L, 2 and D positions. Check that the gear change corresponds to the shift position.

If any abnormality is found in the above test, the problem lies in transmission itself.

- 3. CONNECT SOLENOID WIRE**
- 4. CANCEL OUT DIAGNOSTIC TROUBLE CODE**  
(See page AT-111)

**REFERENCE: Possible gear positions in accordance with solenoid operating conditions.**

Position	NORMAL			NO. 1 SOLENOID MALFUNCTIONING			NO.2 SOLENOID MALFUNCTIONING			BOTH SOLENOIDS MALFUNCTIONING		
	Solenoid Valve		Gear Position	Solenoid Valve		Gear Position	Solenoid Valve		Gear Position	Solenoid Valve		Gear Position
	No. 1	No. 2		No. 1	No. 2		No. 1	No. 2		No. 1	No.2	
D position	ON	OFF	1 st	X	ON	3rd	ON	X	1st	X	X	O/D
	ON	ON	2nd	X	ON	3rd	OFF	X	O/D	X	X	O/D
	OFF	ON	3rd	X	ON	3rd	OFF	X	O/D	X	X	O/D
	OFF	OFF	O/D	X	OFF	O/D	OFF	X	O/D	X	X	O/D
2 position	ON	OFF	1 st	X	ON	3rd	ON	X	1st	X	X	3rd
	ON	ON	2nd	X	ON	3rd	OFF	X	3rd	X	X	3rd
	OFF	ON	3rd	X	ON	3rd	OFF	X	3rd	X	X	3rd
L position	ON	OFF	1st	X	OFF	1st	ON	X	1 st	X	X	1st
	ON	ON	2nd	X	ON	2nd	ON	X	1 st	X	X	1st

X: Malfunctions

# Electronic Control System

## PRECAUTION

Do not open the cover or the case of the ECM and various computer unless absolutely necessary. (If the IC terminals are touched, the IC may be destroyed by static electricity.)

## ELECTRONIC CONTROL CIRCUIT

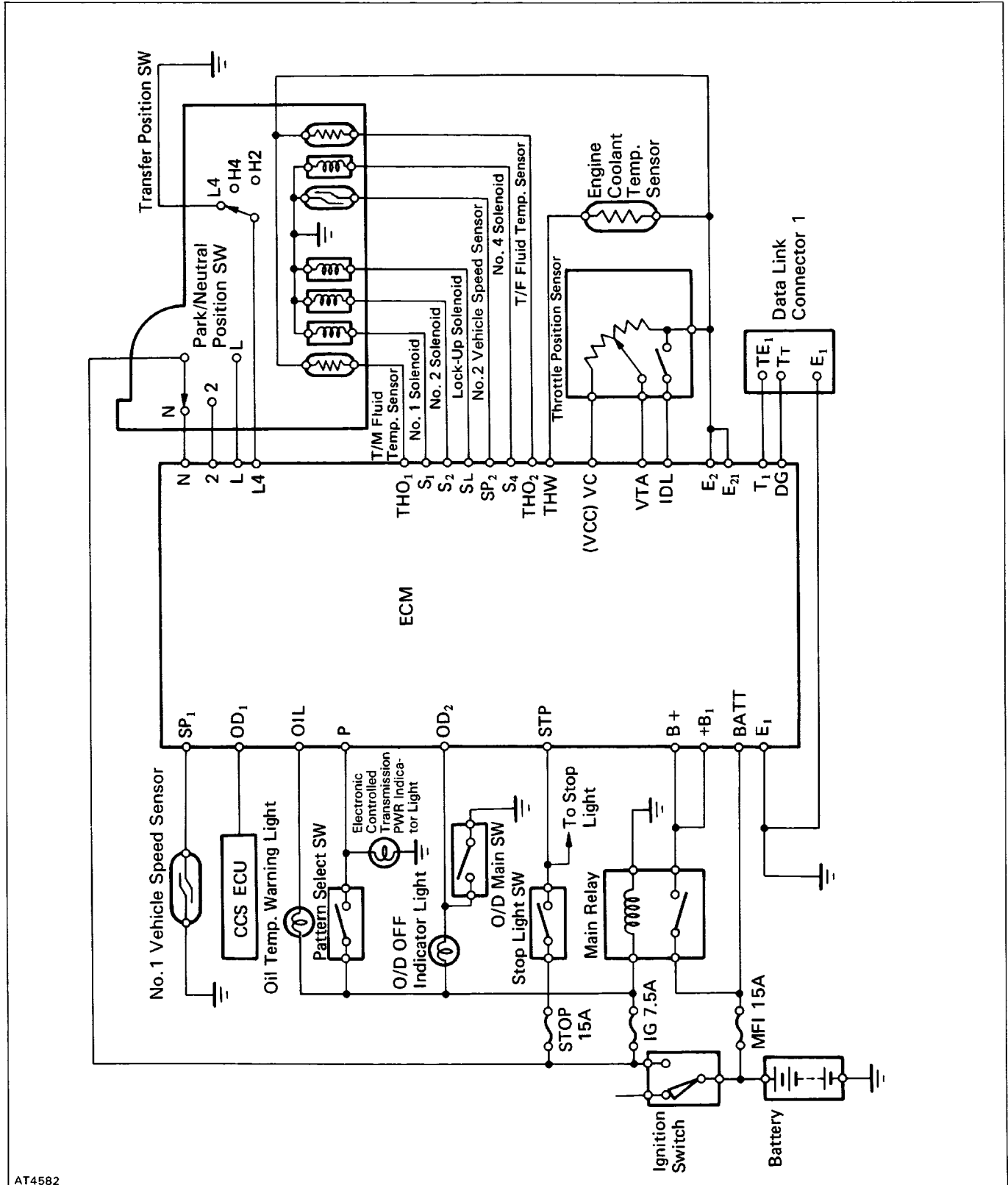

# ELECTRONIC CONTROL COMPONENTS

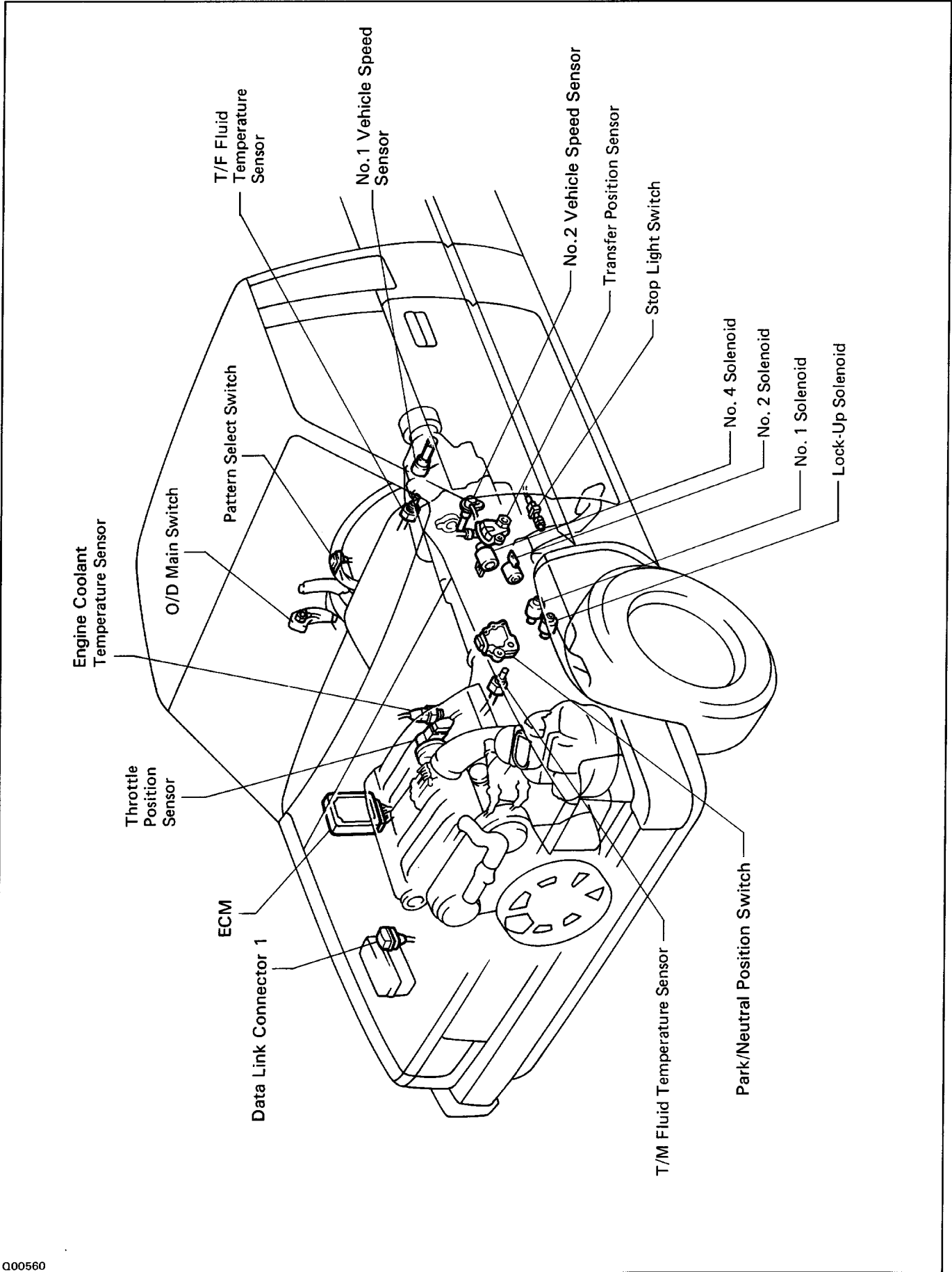

## TROUBLESHOOTING FLOW-CHART

## Trouble No. 1 No Shifting

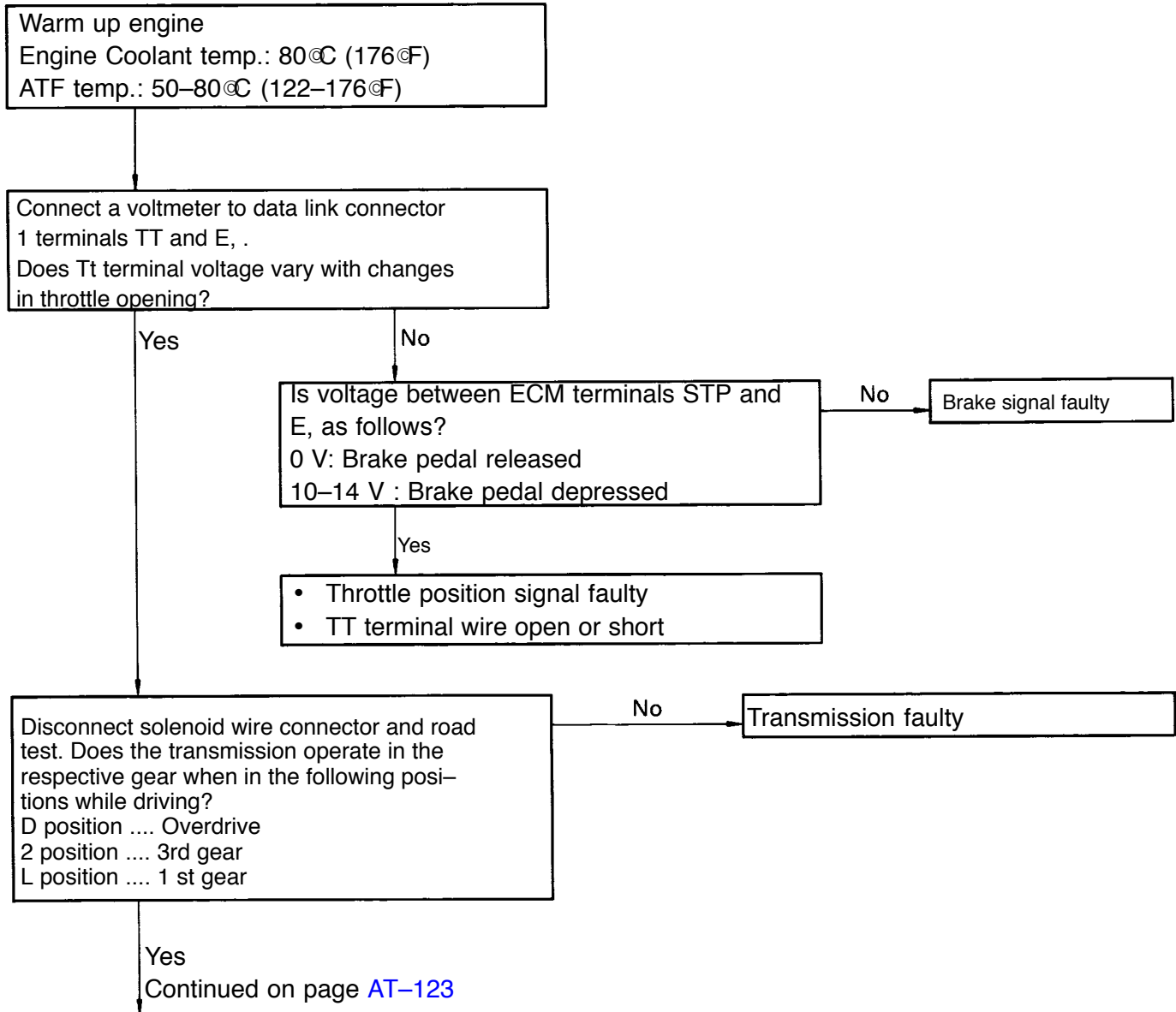

Continued from page AT-122

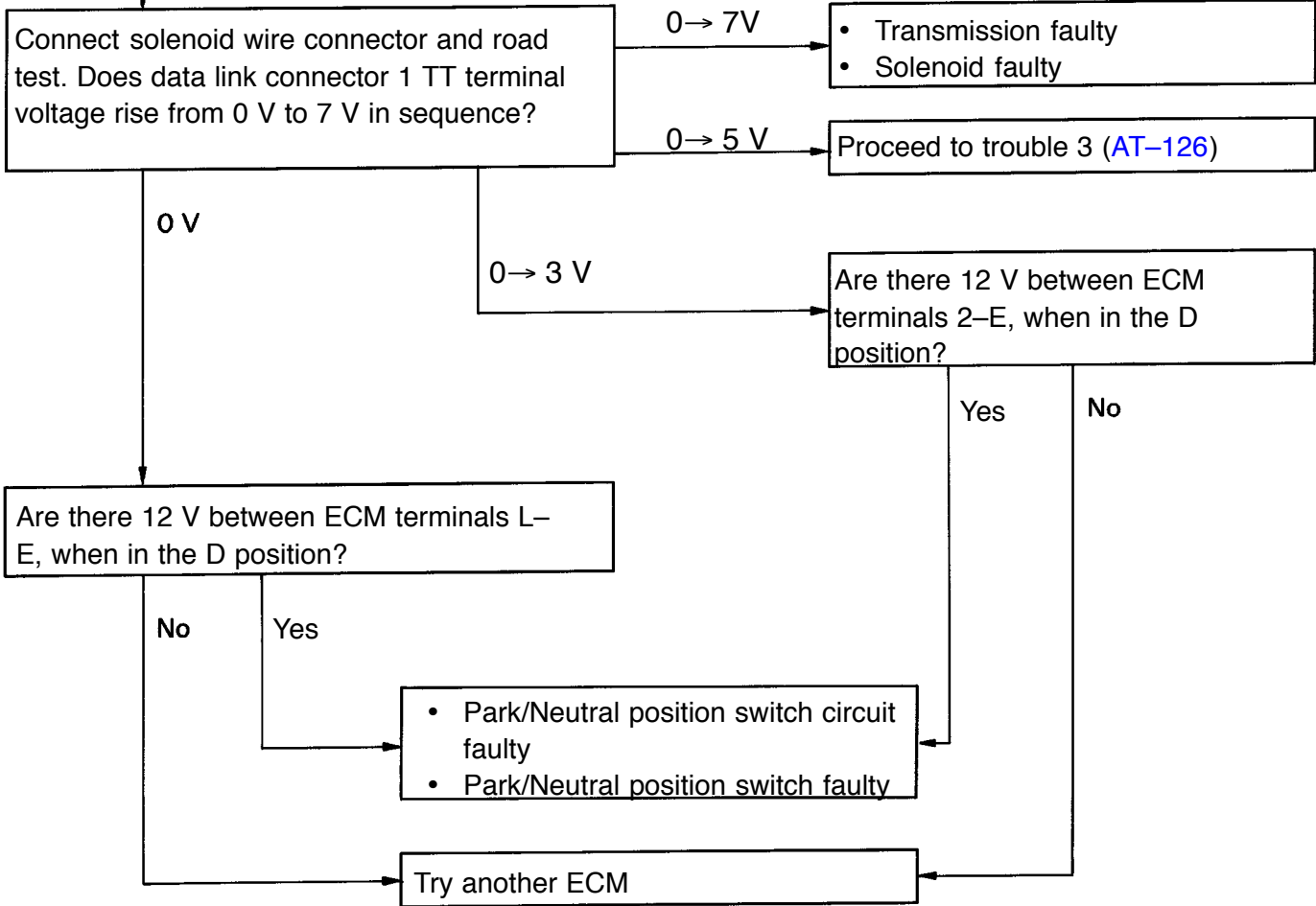



**Trouble No.2 Shift point too high or too low**

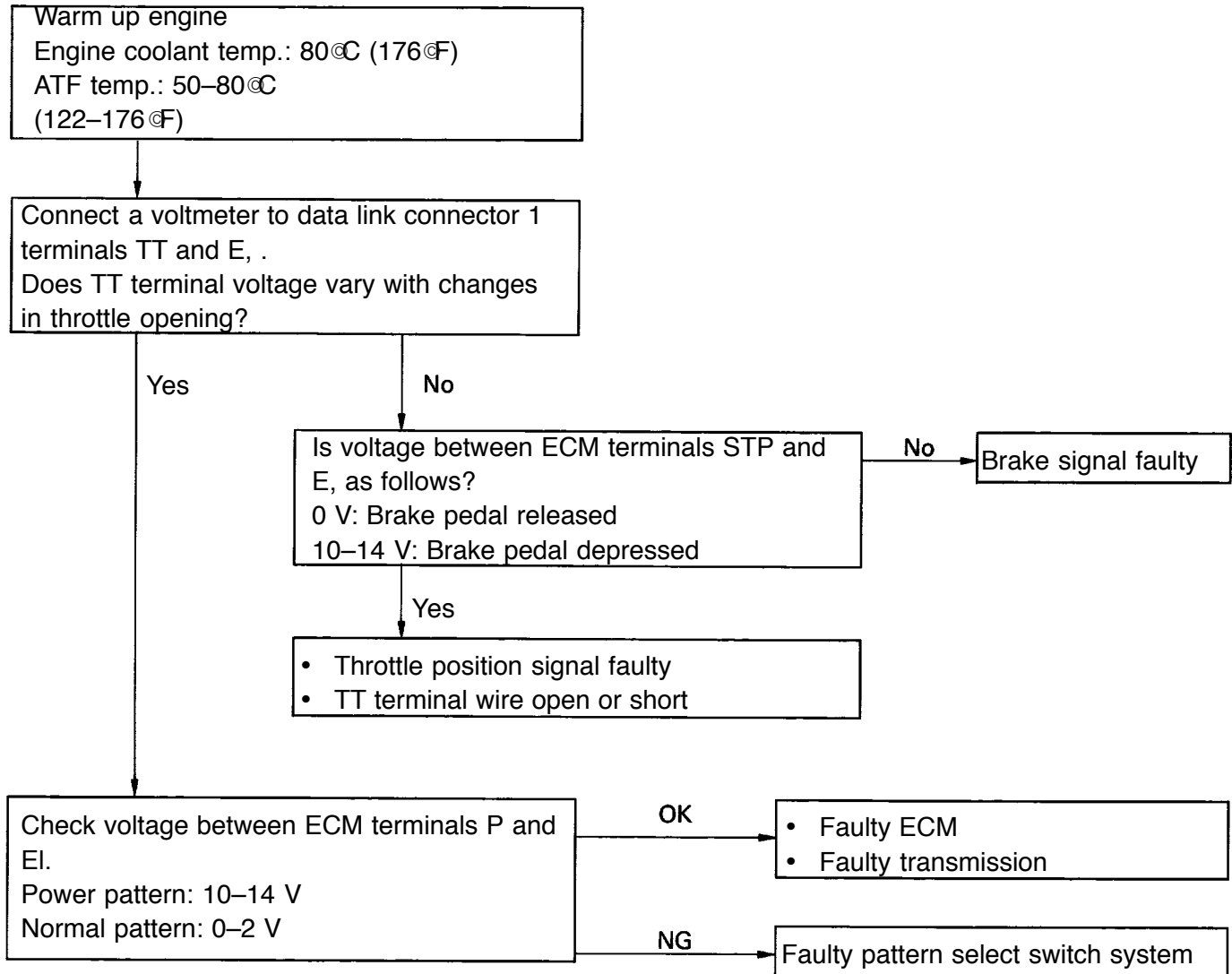

**Trouble No.3 No up-shift to overdrive (After warm-up)**

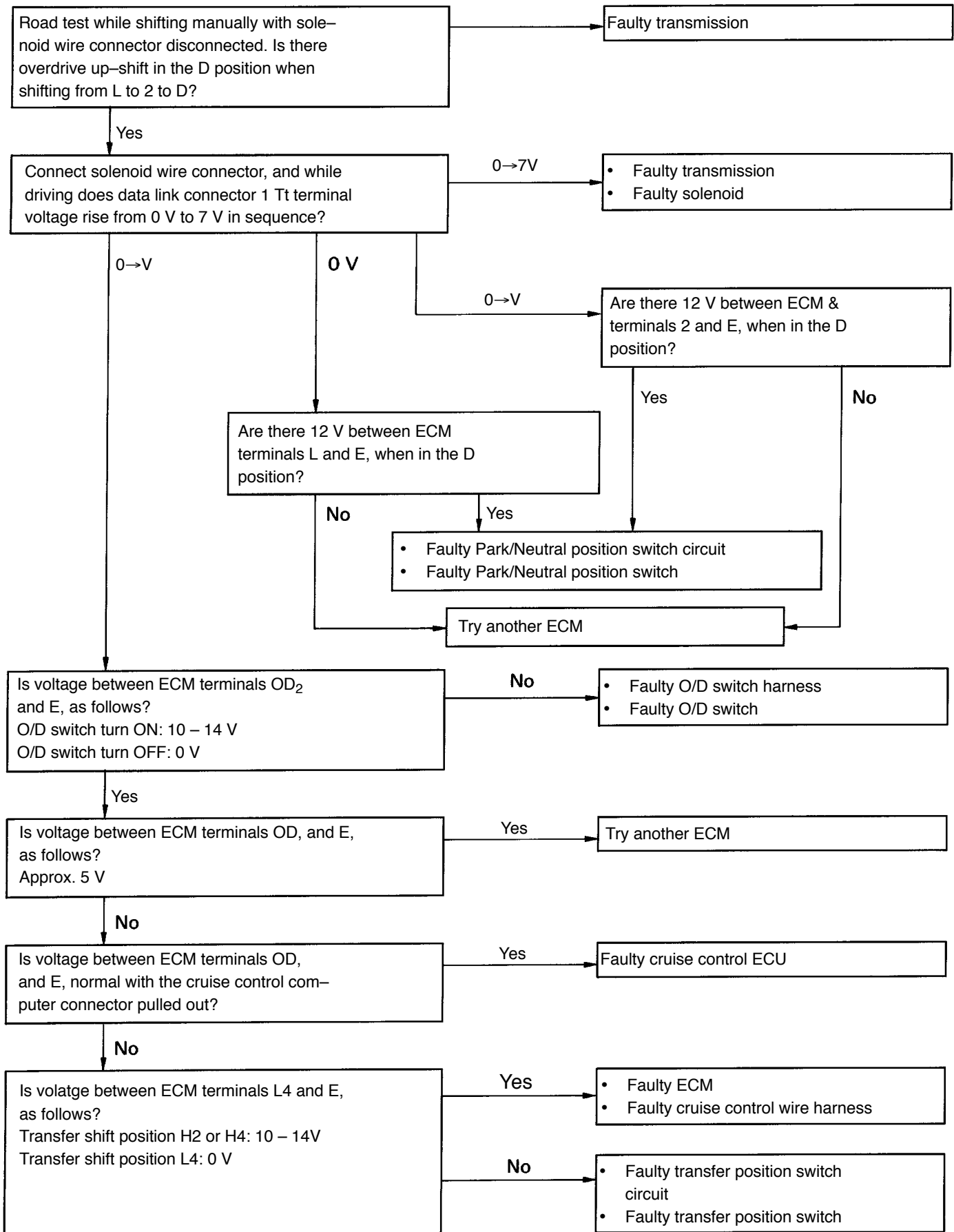

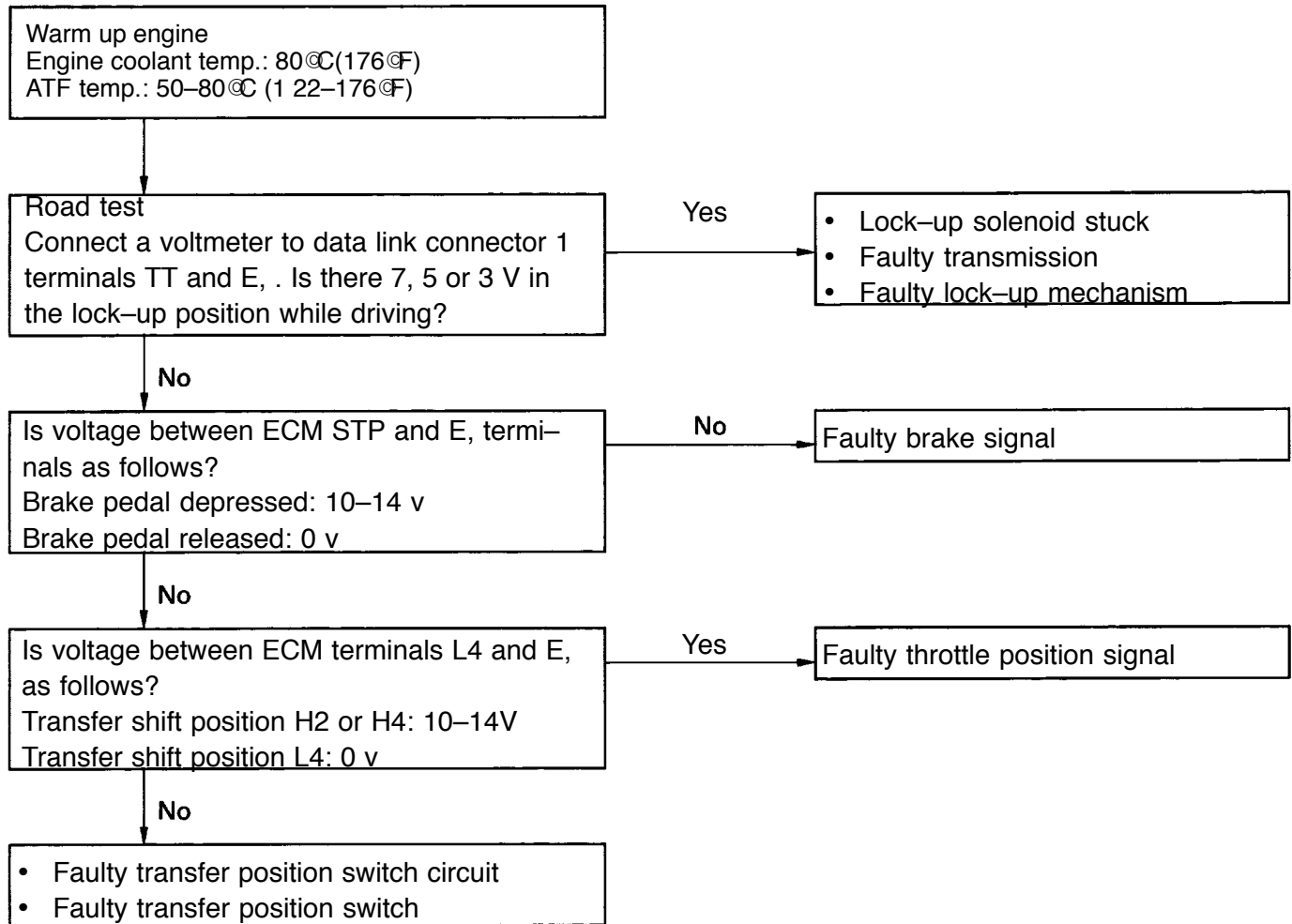
**Trouble No. 4 No lock-up (After warm-up)**

**Trouble No.5 Transfer gear no change L4 from H4**

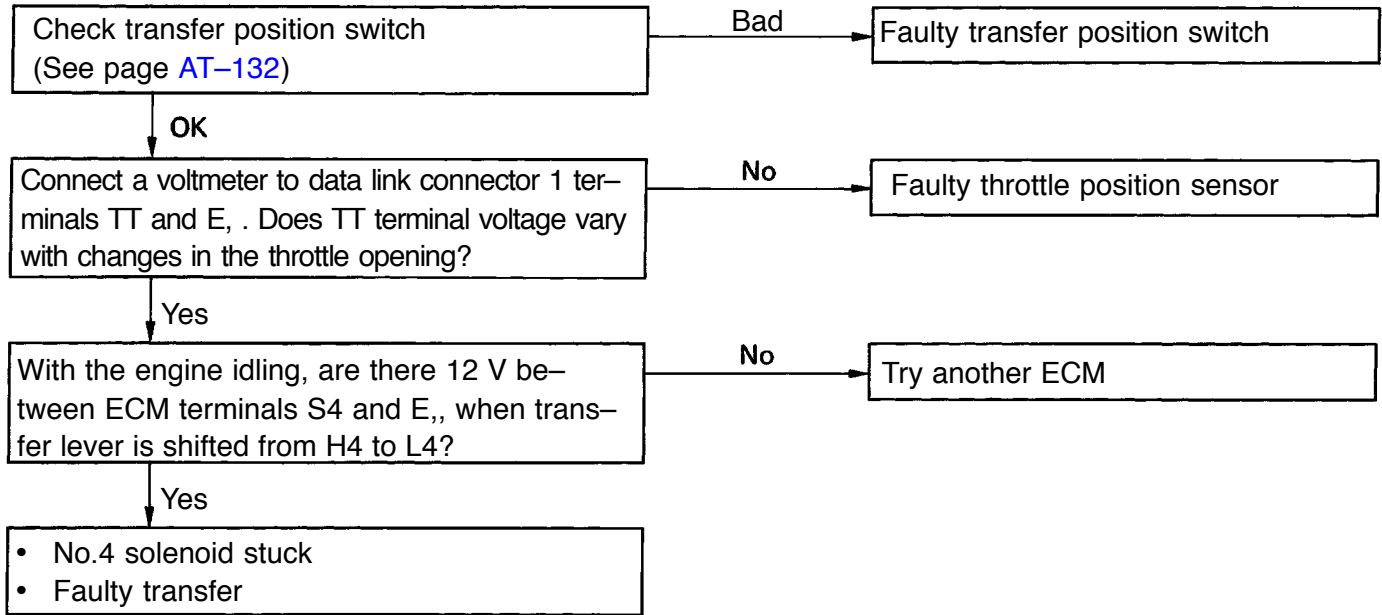

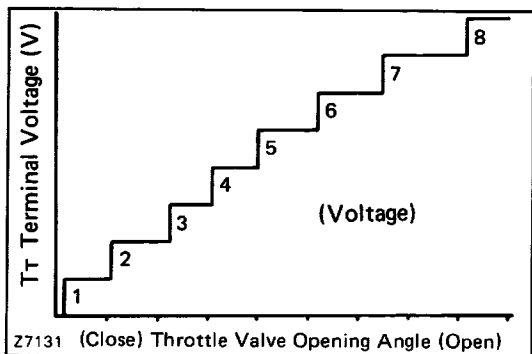
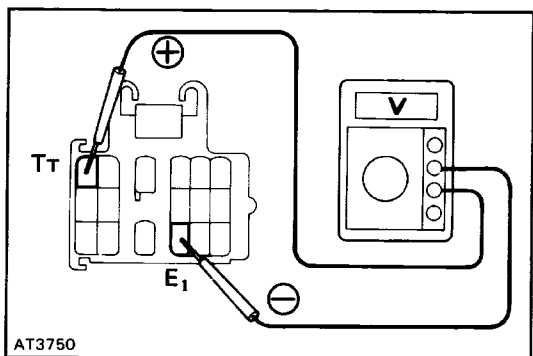

## INSPECTION OF TT TERMINAL VOLTAGE

### 1. INSPECT THROTTLE POSITION SENSOR SIGNAL

- (a) Turn the ignition switch to ON. Do not start the engine.
- (b) Connect a voltmeter to data link connector 1 terminals Tt and E<sub>1</sub>.
- (c) While slowly depressing the accelerator pedal, check that TT terminal voltage rises in sequence. If the voltage does not change in proportion to the throttle opening angle, there is a malfunction in the throttle position sensor or circuit.

### 2. INSPECT BRAKE SIGNAL

- (a) Depress the accelerator pedal until the TT terminal indicates 8 V.
  - (b) Depress the brake pedal and check the voltage reading from the TT terminal.
    - Brake pedal depressed ..... 0 V
    - Brake pedal released ..... 8 V
- If not as indicated, there is a malfunction in either the stop light switch or circuit.

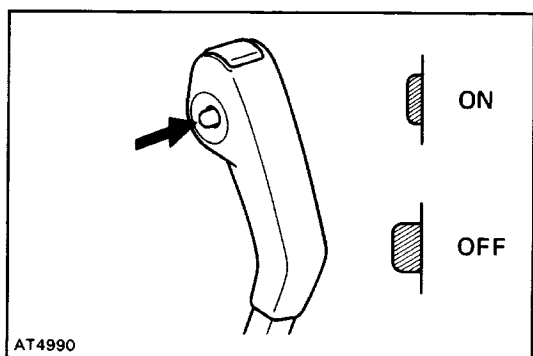

### 3. INSPECT EACH UP-SHIFT POSITION

- (a) Warm up the engine.
  - Engine Coolant temperature: 800C (1760F)**
- (b) Turn the O/D switch to "ON".
- (c) Place the pattern select switch in "Normal" and the shift lever into the D position.
- (d) During a road test (above 10 km/h or 6 mph) check that voltage at the TT terminal is as indicated below for each up-shift position.

If the voltage rises from 0 V to 7 V in the sequence shown, the control system is okay.

The chart on the left shows the voltmeter reading and corresponding gears.

HINT: Determine the gear position by a light shock or change in engine rpm when shifting. The lock-up clutch will turn ON only infrequently during normal 2nd and 3rd gear operation. To trigger this action, press the accelerator pedal to 50% or more of its stroke. At less than 50%, the voltage may change in the sequence 2 V-4 V-6 V-7V.

T <sub>T</sub> Terminal (V)	Gear Position
0	1st
2	2nd
3	2nd Lock-up
4	3rd
5	3rd Lock-up
6	O/D
7	O/D Lock-up

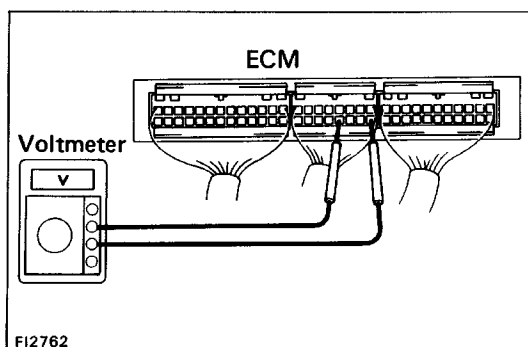

### INSPECTION OF ELECTRONIC CONTROL COMPONENTS

#### 1. INSPECT VOLTAGE OF ECM CONNECTOR

- (a) Remove the cowl side trim of passenger side.
- (b) Turn on the ignition switch.
- (c) Measure the voltage at each terminal.

FI2762

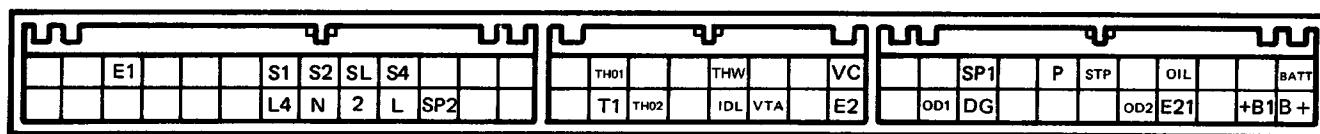

FI2796

Terminal	Measuring condition	Voltage i V j	
S <sub>1</sub> - E <sub>1</sub>	-	10 - 14	
S <sub>2</sub> , S <sub>L</sub> - E <sub>1</sub>	-	0	
S <sub>4</sub> - E <sub>1</sub>	Transfer shift position H2 or H4	0	
	Transfer shift position L4	10 - 14	
P - E <sub>1</sub>	PWR pattern	10 - 14	
	NORM pattern	0 - 2	
STP - E <sub>1</sub>	Brake pedal is depressed	10 - 14	
	Brake pedal is released	0	
THW - E <sub>2</sub> (E <sub>21</sub> )	Engine Coolant temp. 80°C (176°F)	0.1 - 1.0	
IDL - E <sub>2</sub> (E <sub>21</sub> )	Throttle valve fully closed	0	
	Throttle valve open	10 - 14	
VTA - E <sub>2</sub> (E <sub>21</sub> )	Throttle valve fully closed	0.1 - 1.0	
	Throttle valve fully open	3 - 5	
VC (VCC) - E <sub>2</sub> (E <sub>21</sub> )	-	4 - 6	
OD <sub>1</sub> - E <sub>1</sub>	-	5	
OD <sub>2</sub> - E <sub>1</sub>	O/D main switch turned ON	10 - 14	
	O/D main switch turned OFF	0	
SP <sub>1</sub> - E <sub>1</sub>	Cruise control main switch OFF	Standing still	0 or 5
		Vehicle moving	2 - 3
SP <sub>2</sub> - E <sub>1</sub>	Standing still	0 or 5	
		Vehicle moving	2 - 3

Terminal	Measuring condition	Voltage (V)
N - E <sub>1</sub>	N position	10 - 14
	Except N position	0 - 2
2 - E <sub>1</sub>	2 position	10 - 14
	Except 2 position	0 - 2
L - E <sub>1</sub>	L position	10 - 14
	Except L position	0 - 2
L <sub>4</sub> - E <sub>1</sub>	Transfer shift position H2 or H4	10 - 14
	Transfer shift position L4	0
OIL - E <sub>1</sub>	-	10 - 14
THO <sub>1</sub> , THO <sub>2</sub> - E <sub>2</sub> THO (E <sub>21</sub> )	Fluid temp. 20°C (68°F)	4 - 5
B+ (+B <sub>1</sub> ) - E <sub>1</sub>	-	10 - 14
BATT - E <sub>1</sub>	-	10 - 14

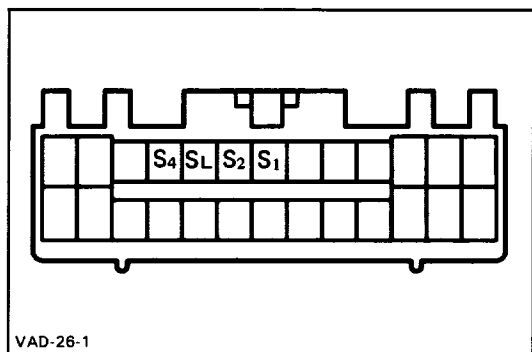

## 2. INSPECT SOLENOID

- Disconnect the connector from the ECM.
- Measure the resistance between S<sub>1</sub>, S<sub>2</sub>, S<sub>L</sub>, S<sub>4</sub> and ground.

**Resistance: 11-15**

- Apply battery positive voltage to each terminal. Check that an operation noise can be heard from the solenoid.

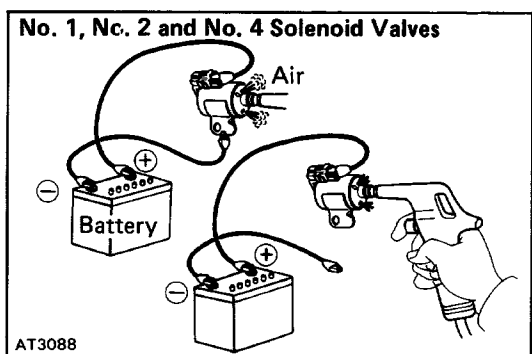

## 3. CHECK SOLENOID SEALS

If there is foreign material in the solenoid valve, there will be no fluid control even with solenoid operation.

- Check No. 1, No. 2 and No. 4 solenoid valves.

Check that the solenoid valves do not leak when low-pressure compressed air is applied.

When supply battery positive voltage to the solenoids, check that the solenoid valves open.

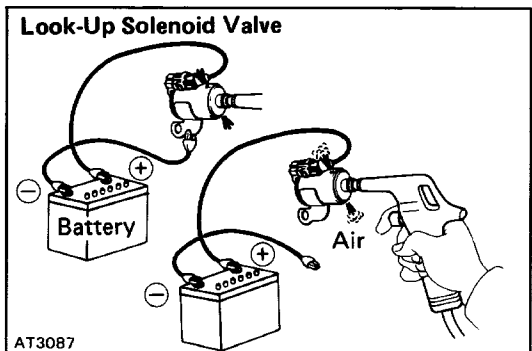

- Check the lock-up solenoid valve.

Applying 490 kPa (5 kgf/cm<sup>2</sup>, 71 psi) of compressed air, check that the solenoid valve opens.

When supply battery positive voltage to the solenoid, check that the solenoid valve does not leak the air.

If a malfunction is found during voltage inspection (step 1.), inspect the components listed below.

**4. INSPECT PARK/ NEUTRAL POSITION SWITCH**  
(See page AT-144)

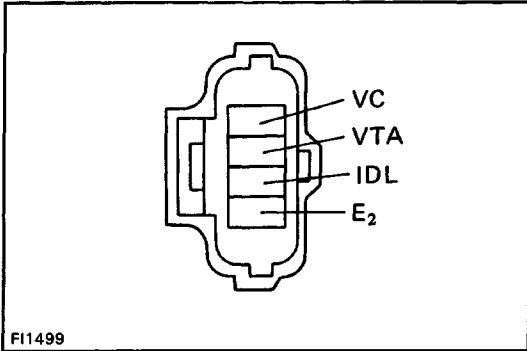

FI1499

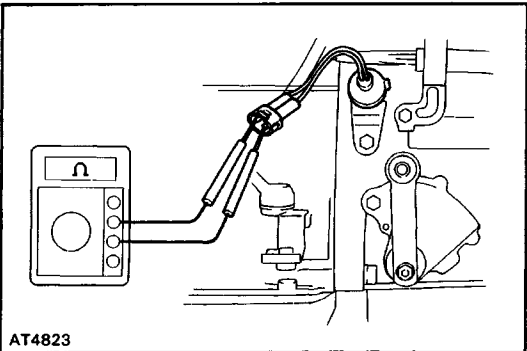

AT4823

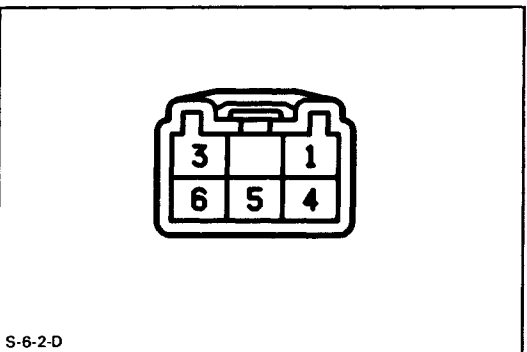

S-6-2-D

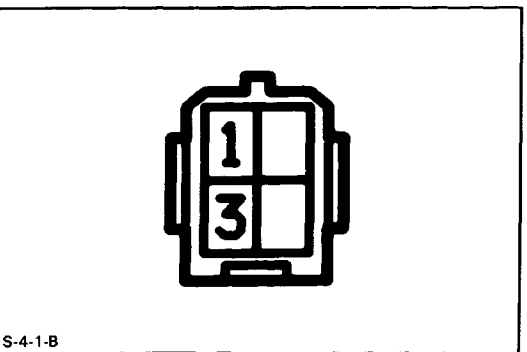

S-4-1-B

**5. INSPECT THROTTLE POSITION SENSOR**

Using an ohmmeter, check the resistance between each terminal.

Terminal	Throttle valve condition	Resistance (k/ )
IDL-E2	Fully closed	Less than 2.3
	Open	Infinity
VC-E2	—	3.9-9.0
VTA-E2	Fully closed	0.47-6.1
	Fully open	3.1-12.1

**6. INSPECT NO.2 VEHICLE SPEED SENSOR**

- (a) Jack up the rear wheel on one side.
- (b) Connect an ohmmeter between the terminals.
- (c) Spin the wheel and check that the meter needle deflects from 0/ to ∞/.

**7. INSPECT NO.1 VEHICLE SPEED SENSOR**

(See step 6. on page AT-131)

**8. INSPECT PATTERN SELECT SWITCH**

Using an ohmmeter, check the continuity of the terminals for each switch position.

HINT: As there are diodes inside, be careful of the tester probe polarity.

Terminal	4	6
Pattern		
PWR	○	○
NORM		

**9. INSPECT O/D SWITCH**

Using an ohmmeter, check the continuity of the terminals for each switch position.

Terminal	1	3
SW position		
ON		
OFF	○	○

**10. INSPECT ENGINE COOLANT TEMPERATURE SENSOR**

(See page FI-201 )



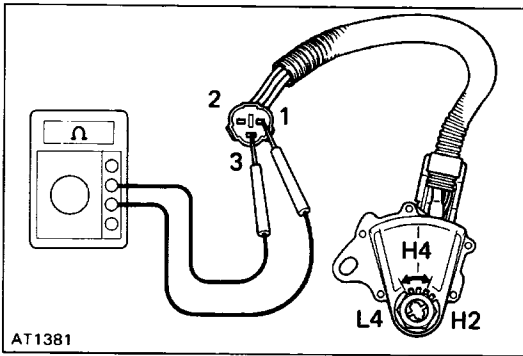

### 11. INSPECT TRANSFER POSITION SWITCH

Check that there is continuity between each terminal.

Shift position	Terminal		
	1	2	3
H4	○	—	○
L4	○	○	○
H2			

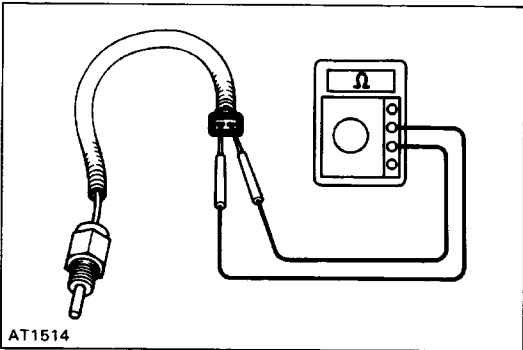

### 12. INSPECT TRANSMISSION AND TRANSFER FLUID TEMPERATURE SENSOR

Measure the resistance between terminals.

Oil Temperature	Resistance ( / )
20°C ( 68°F)	5k - 20k
120°C (248°F)	540 - 690
150°C (302°F)	300 - 340

# Mechanical System Tests

## STALL TEST

The object of this test is to check the overall performance of the transmission and engine by measuring the stall speeds in the D and R positions.

### NOTICE:

- Perform the test at normal operating fluid temperature (50–80°C or 122–176°F).
- Do not continuously run this test longer than 5 seconds.
- To ensure safety, conduct this test in a wide, clear, level area, which provides good traction.
- The stall test should always be carried out in pairs. One should observe the conditions of wheels or wheel stoppers outside the vehicle while the other is performing the test.

### MEASURE STALL SPEED

- (a) Chock the front and rear wheels.
- (b) Connect a tachometer to the engine.
- (c) Fully apply the parking brake.
- (d) Keep your left foot pressed firmly on the brake pedal.
- (e) Shift the transfer lever to the H2 position.
- (f) Start the engine.
- (g) Shift into the D position. Step all the way down on the accelerator pedal with your right foot.  
Quickly read the stall speed at this time.

**NOTICE: Release the accelerator pedal and stop test if the rear wheels begin to rotate before the engine speed reaches specified stall speed.**

**Stall speed: 2,850 ± 150 RPM**

- (h) Perform the same test in R position.

### EVALUATION

- (a) If the stall speed is the same for both positions but lower than specified value:

Engine output may be insufficient

Stator one-way clutch is not operating properly

HINT: If more than 600 RPM below the specified value, the torque converter clutch could be faulty.

- (b) If the stall speed in D position is higher than specified:

Line pressure too low

Forward clutch slipping

No.2 one-way clutch not operating properly

O/D one-way clutch not operating properly

Transfer direct clutch slipping

- (c) If the stall speed in R position is higher than specified:

Line pressure too low

Direct clutch slipping

First and reverse brake slipping

O/D one-way clutch not operating properly

Transfer direct clutch slipping

- (d) If the stall speed in both R and D positions are higher than specified:

Line pressure too low

Improper fluid level

O/D one-way clutch not operating properly

Transfer direct clutch slipping

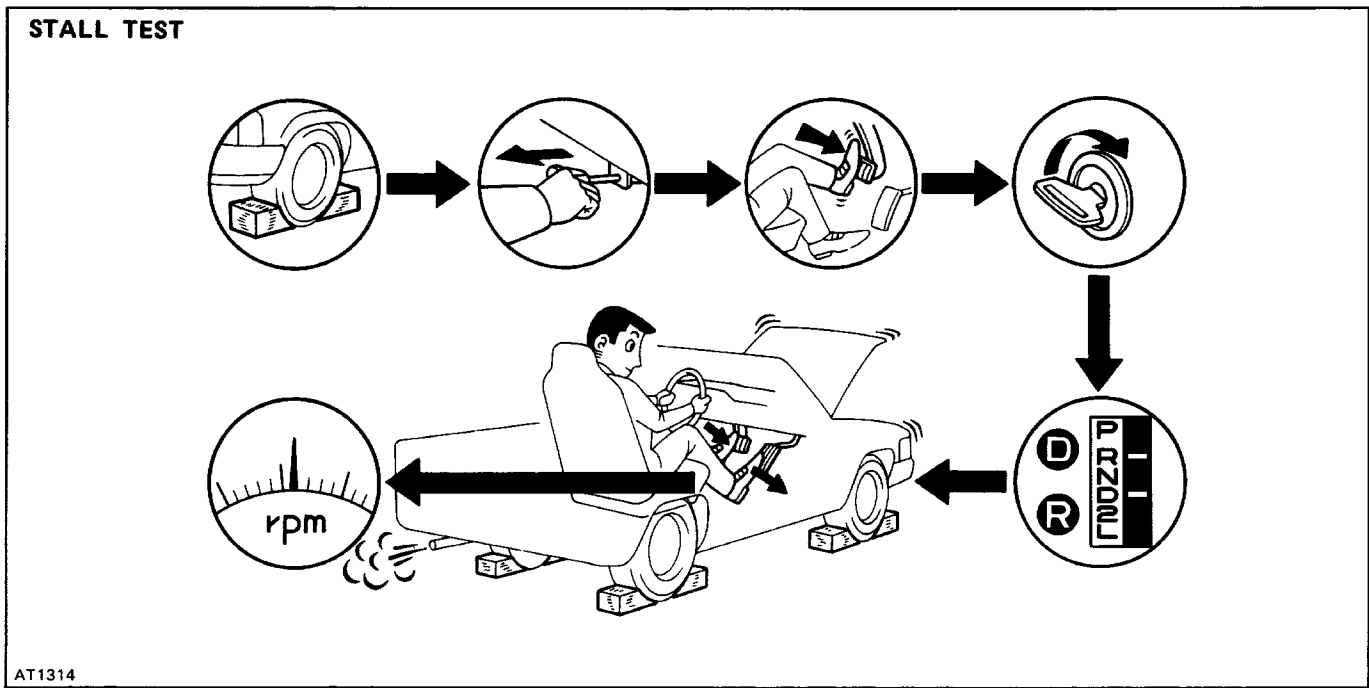

## TIME LAG TEST

When the shift lever is shifted while the engine is idling, there will be a certain time lapse or lag before the shock can be felt. This is used for checking the condition of the O/D direct clutch, forward clutch, direct clutch and first and reverse brake.

### NOTICE:

Perform the test at normal operating fluid temperature (50–80°C or 122–176°F).

Be sure to allow one minute interval between tests.

Make three measurements and take the average value.

### MEASURE TIME LAG

- (a) Fully apply the parking brake.
- (b) Shift the transfer shift lever to the H2 position.
- (c) Start the engine and check the idle speed.

**Idle speed: 850 RPM**

**(N position)**

- (d) Shift the shift lever from N to D position. Using a stop watch, measure the time it takes from shifting the lever until the shock is felt.

**Time lag: Less than 1.2 seconds**

- (e) In same manner, measure the time lag for N–R.

**Time lag: Less than 1.5 seconds**

### EVALUATION

- (a) If N–D time lag is longer than specified:
  - Line pressure too low
  - Forward clutch worn
  - O/D one-way clutch not operating properly
- (b) If N–R time lag is longer than specified:
  - Line pressure too low
  - Direct clutch worn
  - First and reverse brake worn
  - O/D one-way clutch not operating properly

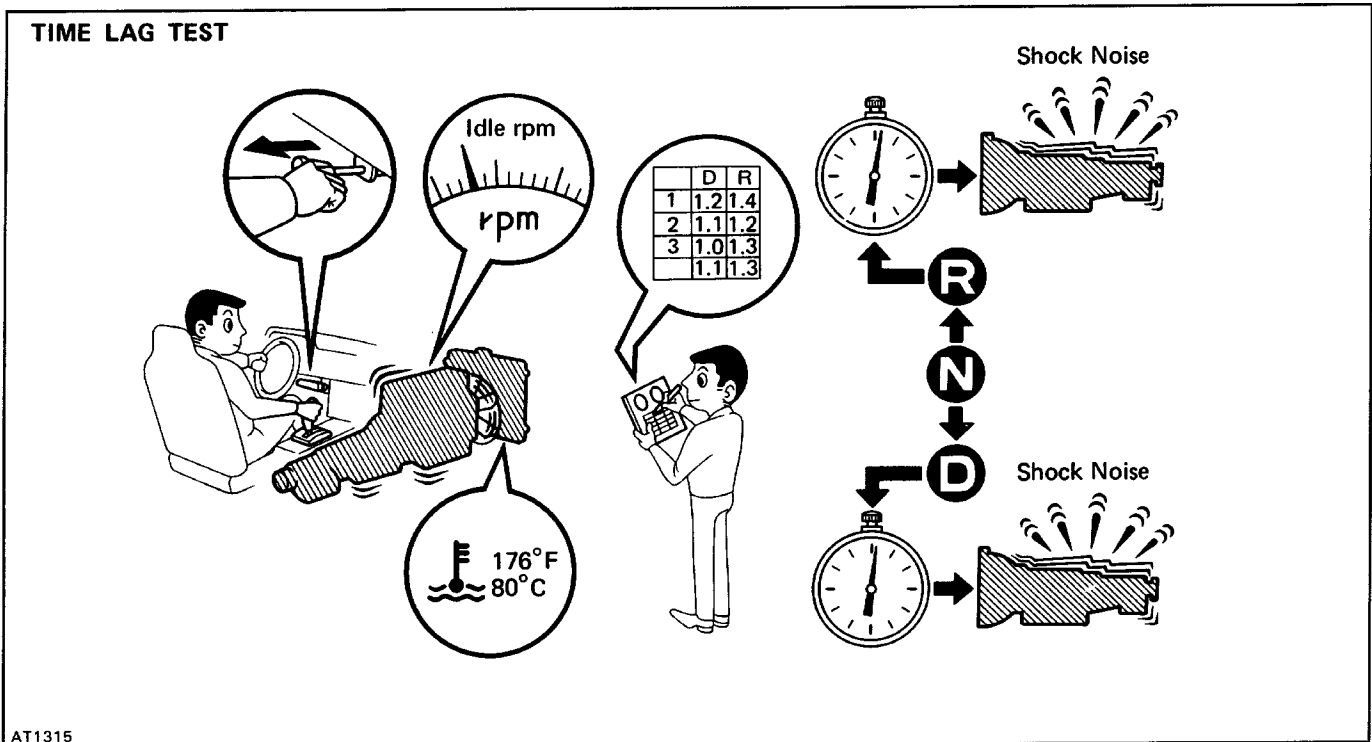

AT1315

## HYDRAULIC TEST PREPARATION

- (a) Warm up the transmission fluid.
- (b) Remove the transmission case test plug and connect the hydraulic pressure gauge.  
SST 09992-00094 (Oil pressure gauge)

**NOTICE:**

Perform the test at normal operating fluid temperature (50–80°C or 122–176°F).

The line pressure test should always be carried out in pairs. One should observe the conditions of wheels or wheel stoppers outside the vehicle while the other is performing the test.

### MEASURE LINE PRESSURE

- (a) Fully apply the parking brake and check the four wheels.
- (b) Start the engine and check idling RPM.
- (c) Keep your left foot pressed firmly on the brake pedal and shift into D position.
- (d) Measure the line pressure when the engine is idling.
- (e) Press the accelerator pedal all the way down. Quickly read the highest line pressure when engine speed reaches stall speed.

**NOTICE:** Release the accelerator pedal and stop test if the rear wheels begin to rotate before the engine speed reaches specified stall speed.

(f) In the same manner, perform the test in R position. kPa (kgf/cm<sup>2</sup>,psi)

D position		R position	
Idling	Stall	Idling	Stall
427 – 481	1,118 – 1,363	510 – 608	1,373 – 1,716
(4.3 – 4.9, 61 – 70)	(11.4 – 13.9, 162 – 198)	(5.2 – 6.2, 74 – 88)	(14.0 – 17.5, 199 – 249)

If the measured pressures are not up to specified values, recheck the throttle cable adjustment and perform a retest.

**EVALUATION**

(a) If the measured values at all positions are higher than specified:

Throttle cable out of adjustment

Throttle valve defective

Regulator valve defective

(b) If the measured values at all positions are lower than specified:

Throttle cable out of adjustment

Throttle valve defective

Regulator valve defective

Oil pump defective

O/D direct clutch defective

Transfer direct clutch defective (H2, H4)

Transfer front drive clutch defective (H4, L4)

Transfer low speed brake defective (L4)

(c) If pressure is low in the D position only:

D position circuit fluid leakage

Forward clutch defective

(d) If pressure is low in the R position only:

R position circuit fluid leakage

Direct clutch defective

First and reverse brake defective

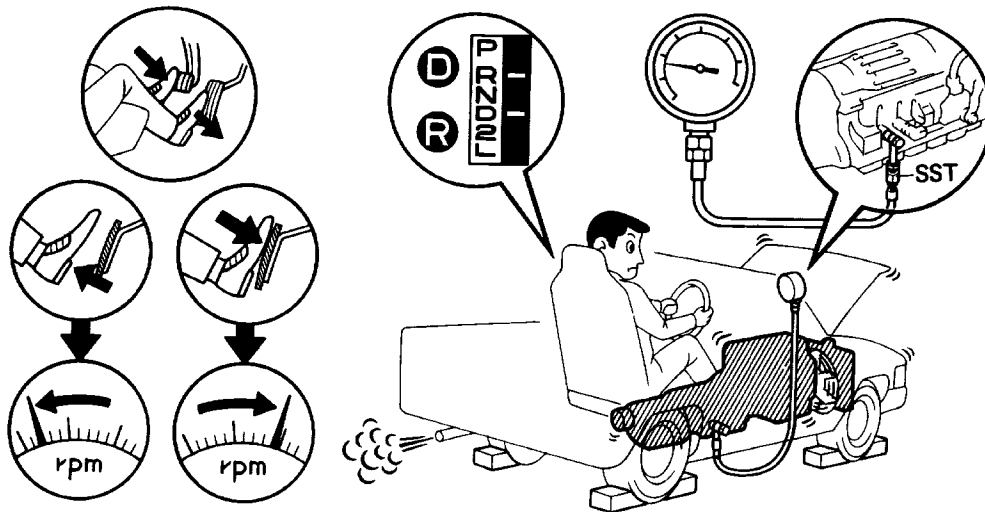
**HYDRAULIC TEST**

## ROAD TEST

**NOTICE:** Perform the test at normal operating fluid temperature (50–80°C or 122–176°F).

**HINT:** The transmission shift points for the H2, H4 and L4 transfer positions are different. Also, the O/D gear and lock-up are cancelled when L4 is engaged.

### 1. D POSITION TEST IN NORM AND PWR PATTERN POSITIONS

Shift into the D position and hold the accelerator pedal constant at the full throttle valve opening position.

Check the following:

- (a) 1–2, 2–3 and 3–O/D up-shifts should take place, and shift points should conform to those shown in the automatic shift schedule.

Conduct a test under both Normal and Power patterns.

**HINT:** There is no O/D up-shift or lock-up when the engine coolant temp. is below 70°C (158°F).

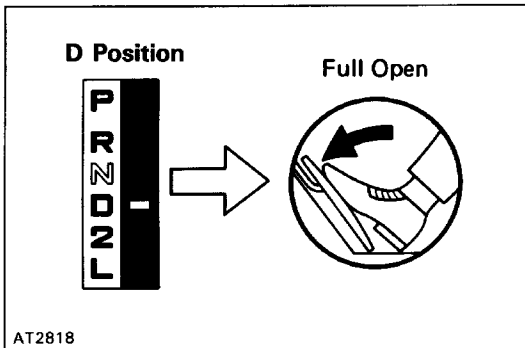

AT2818

### EVALUATION

- (1) If there is no 1–2 up-shift:
  - No. 2 solenoid is stuck
  - 1–2 shift valve is stuck
- (2) If there is no 2–3 up-shift:
  - No. 1 solenoid is stuck
  - 2–3 shift valve is stuck
- (3) If there is no 3–i O/D up-shift:
  - 3–4 shift valve is stuck
- (4) If the shift point is defective:
  - Throttle valve, 1–2 shift valve, 2–3 shift valve, 3–4 shift valve etc., are defective
- (5) If the lock-up is defective:
  - Lock-up solenoid is stuck
  - Lock-up relay valve is stuck

- (b) In the same manner, check the shock and slip at the 1–2, 2–3, and 3–O/D up-shifts

### EVALUATION

If the shock is excessive:

- Line pressure—is too high
- Accumulator is defective
- Check ball is defective

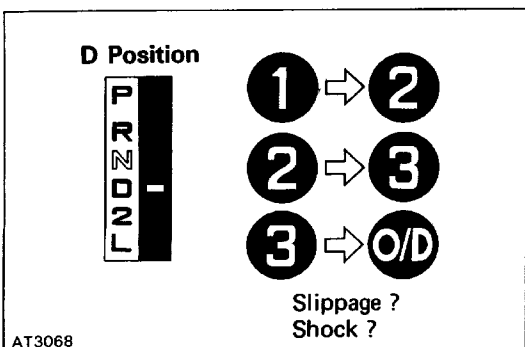

AT3068

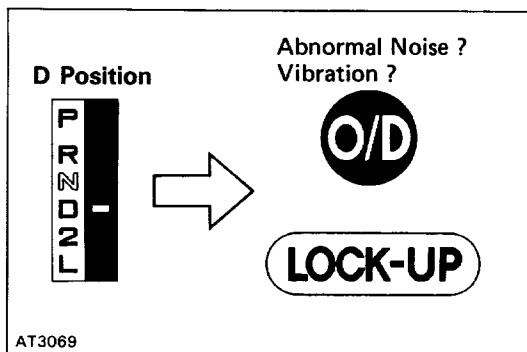

(c) Run at the D position lock-up or O/D gear and check for abnormal noise and vibration.  
HINT: The check for the cause of abnormal noise and vibration must be made with extreme care as it could also be due to loss of balance in the propeller shaft, differential, torque converter clutch, etc.

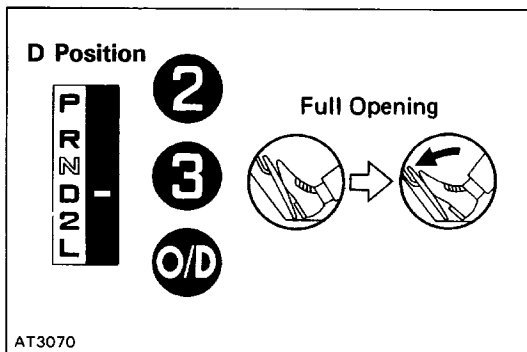

(d) While running in the D position, 2nd, 3rd and O/D gears, check to see that the possible kick-down vehicle speed limits for 2-1, 3-2 and O/D-3 kick-downs conform to those indicated on the automatic shift schedule.  
(e) Check for abnormal shock and slip at kick-down.

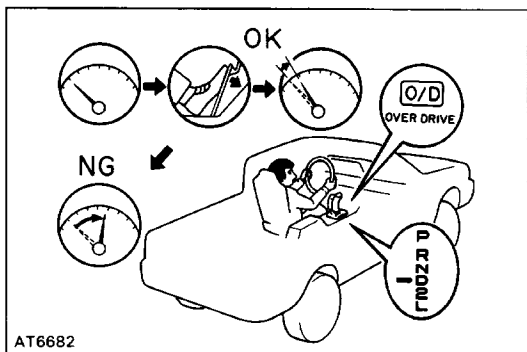

(f) Check for the lock-up mechanism.  
(1) Drive in D position, O/D gear, at a steady speed (lock-up ON) of about 75 km/h (47 mph).  
(2) Lightly depress the accelerator pedal and check that the engine RPM does not change abruptly. If there is a big jump in engine RPM, there is no lock-up.

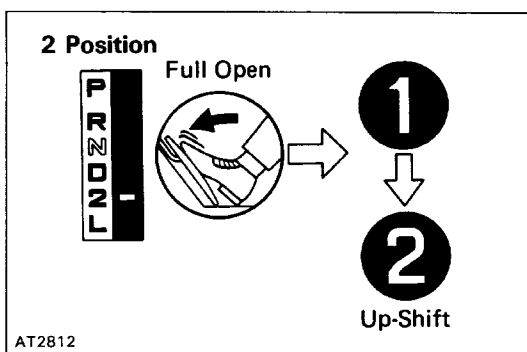

**2. 2 POSITION TEST**

Shift into the 2 position and, while driving with the accelerator pedal held constantly at the full throttle valve opening position, push in one of the pattern selectors and check on the following points.

(a) Check to see that the 1-2 up-shift takes place and that the shift point conforms to it shown on the automatic shift schedule.

HINT:

There is no O/D up-shift and lock-up in the 2 position. To prevent overrun, the transmission up-shifts into 3rd gear at around 100 km/h (62 mph) or more.

(b) While running in the 2 position and 2nd gear, release the accelerator pedal and check the engine braking effect.

**EVALUATION**

If there is no engine braking effect:  
Second coast brake is defective

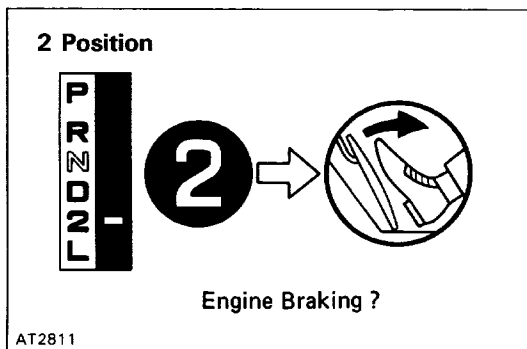

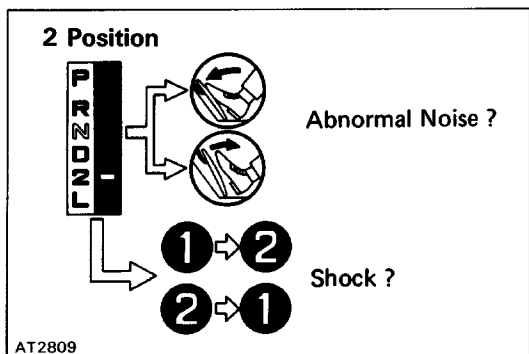

(c) Check for abnormal noise at acceleration and deceleration, and for shock at up-shift and down-shift.

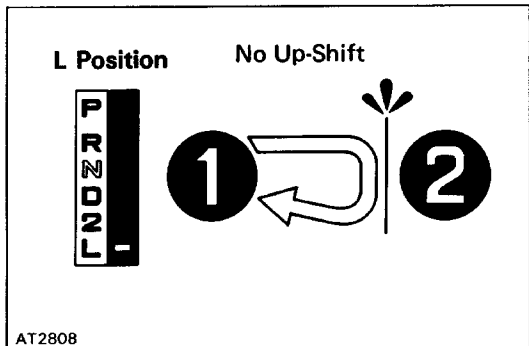

**3. L POSITION TEST**

(a) While running in the L position, check to see that there is no up-shift to 2nd gear.

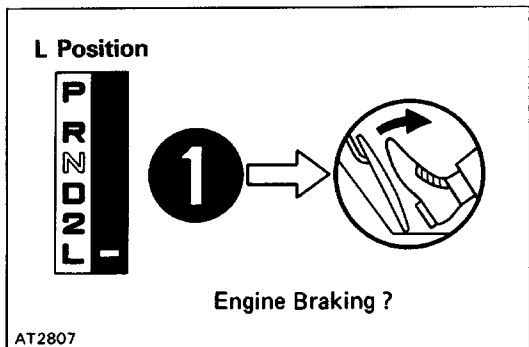

(b) While running in the L position, release the accelerator pedal and check the engine braking effect.

**EVALUATION**

If there is no engine braking effect:

- First and reverse brake is defective

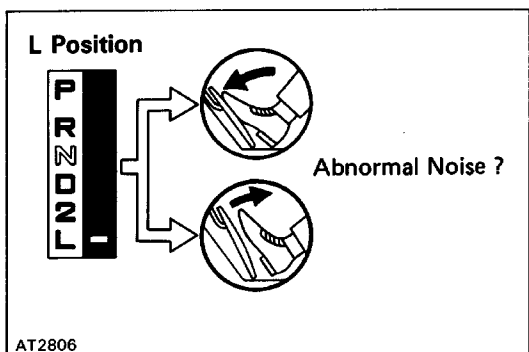

(c) Check for abnormal noise during acceleration and deceleration.

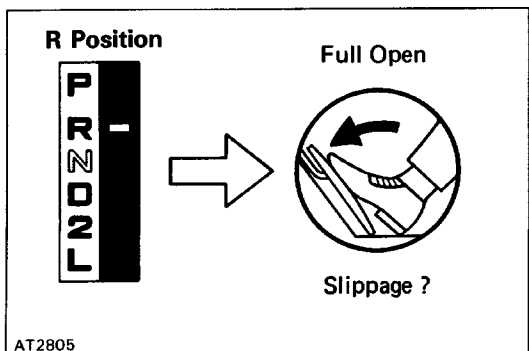

**4. R POSITION TEST**

Shift into the R position and, while starting at wide open throttle, check for slippage.



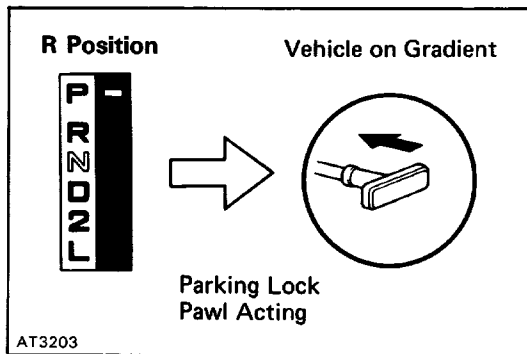

### 5. P POSITION TEST

Stop the vehicle on a gradient (more than 5%) and after shifting into the P position, release the parking brake. Then check to see that the parking lock pawl holds the vehicle in place.

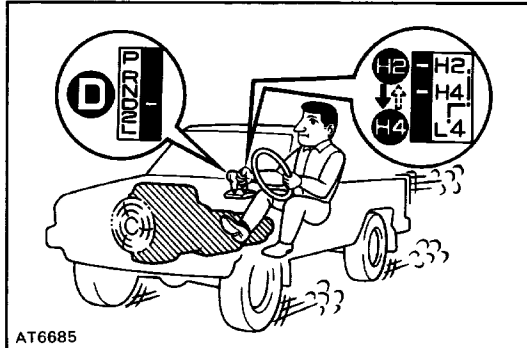

### 6. TRANSFER TEST

(a) When the shift lever is shifted from the H2 to H4, confirm that the vehicle changes from 2 to 4 wheel drive. If it does not, the transfer is faulty.

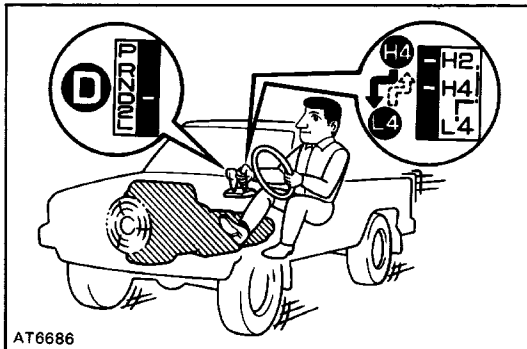

(b) When the transfer lever is shifted from H4 to L4, confirm that the gear changes according to the shifted diagram (See page [AT-141](#)). If it does not, the No.4 solenoid, ECM or transfer faulty.

# Automatic Shift Schedule

Transfer shift position "H2" or "H4"		Throttle valve fully open ( ) Fully closed						km/h (mph)	
		1→2	2→3	3→O/D	[3→O/D]	[O/D→3]	O/D→3	3→2	2→1
D position	NORM	50–53 (31–33)	90–96 (56–60)	131–138 (81–86)	35–39 (22–24)	21–25 (13–16)	125–132 (78–82)	84–91 (52–57)	40–44 (25–27)
	PW R	50–53 (31–33)	90–96 (56–60)	131–138 (81–86)	38–42 (24–26)	21–25 (13–16)	125–132 (78–82)	84–91 (52–57)	40–44 (25–27)
2 position	NORM PWR	43–46 (27–29)	103–109 (64–68)	–	–	–	–	97–103 (60–64)	38–42 (24–42)
L position	NORM PWR	–	–	–	–	–	–	82–89 (51–55)	47–51 (29–32)

Transfer shift position "H2" or "H4"		Throttle valve opening 5%						km/h (mph)		
		Lock-up ON			Lock-up OFF					
		2nd	*3rd	O/D	2nd	*3rd	O/D			
D position	NORM	–	52 – 56 (32 – 35)	64 – 68 (40 – 42)	–	50 – 53 (31 – 33)	55 – 59 (34 – 37)			
	PW R	–	52 – 56 (32 – 35)	64 – 68 (40 – 42)	–	50 – 53 (31 – 33)	55 – 59 (34 – 37)			

\* : O/D switch OFF

**HINT:**

- (1) Lock-up will not occur in 2nd gear unless the throttle valve opening is greater than 50%.
- (2) There is no lock-up in the 2 and L positions.
- (3) In the following cases, the lock-up will be released regardless of the lock-up pattern.
  - When the throttle is completely closed.
  - When the brake light switch is ON.

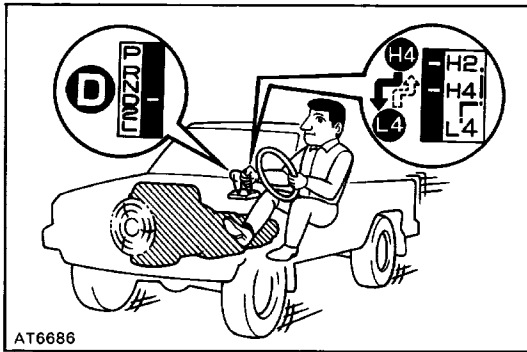

**TRANSFER HIGH-LOW SHIFT RANGE**

The A340H transfer differs from previous manual transfer in that high-low shifting is possible while the vehicle is in motion, though it is not possible at all vehicle speeds or throttle opening angles. The shifting possibility ranges for high-low shifting have been adopted with the idea of improving shifting performance and transfer conditions, and preventing engine overrun.

The shifting possibility ranges are controlled by ECM and when a high-low shift change is made within these ranges the ECM operates the No.4 solenoid which carries out the high-low transfer shift. However, if a transfer is attempted outside the shifting possibility range, the high-low shift will not take place until the vehicle speed and throttle opening angle come within the appropriate range. The high-low shifting possibility ranges are shown in the diagrams below.

There are three shifting possibility ranges for when the transmission gear is in first, second or third gear, which combine with the respective transmission shift positions (L, 2, D).

Although the high-low shift takes place in the 1st gear, 2nd gear and 3rd gear shifting positions with the gears in 1st gear, 2nd gear and 3rd gear respectively, when a high-low shift change is made in 1st gear while in the 2nd gear shifting possibility range only after the transmission has shifted up into second gear does the high-low shift take place. In the 2 position and D position high-low shifting possibility ranges where the 1st and 2nd positions overlap, the high-low shift will take place in first gear if the transmission is in first gear, or in second gear if the transmission is in second gear.

**L Position: High-Low Shift Possibility Range**

\* : This transfer shift is only possible when the I D L contact points of the throttle position sensor are ON.

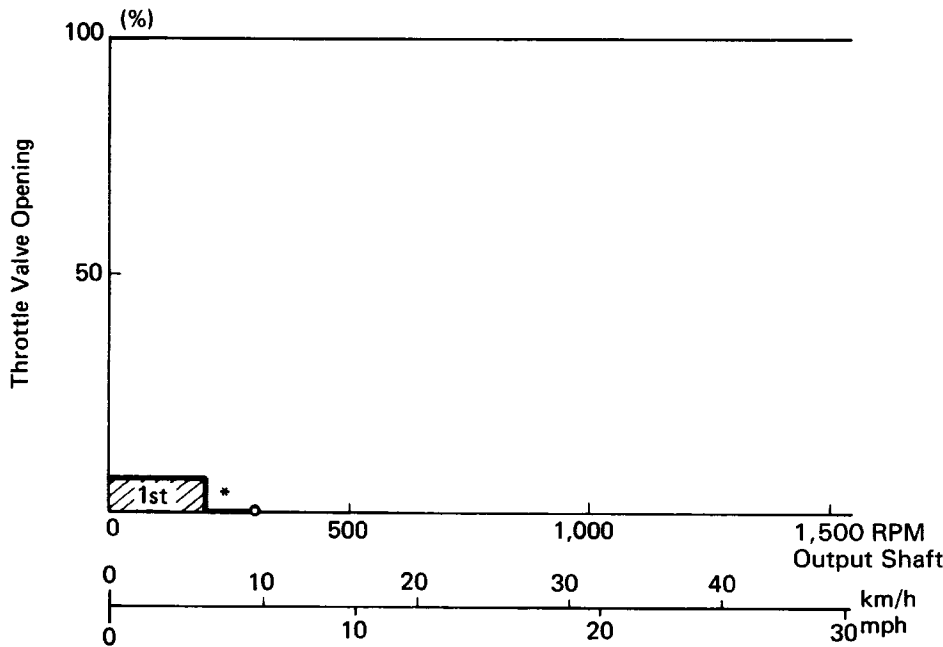

**2 Position: High-Low Shift Possibility Range**

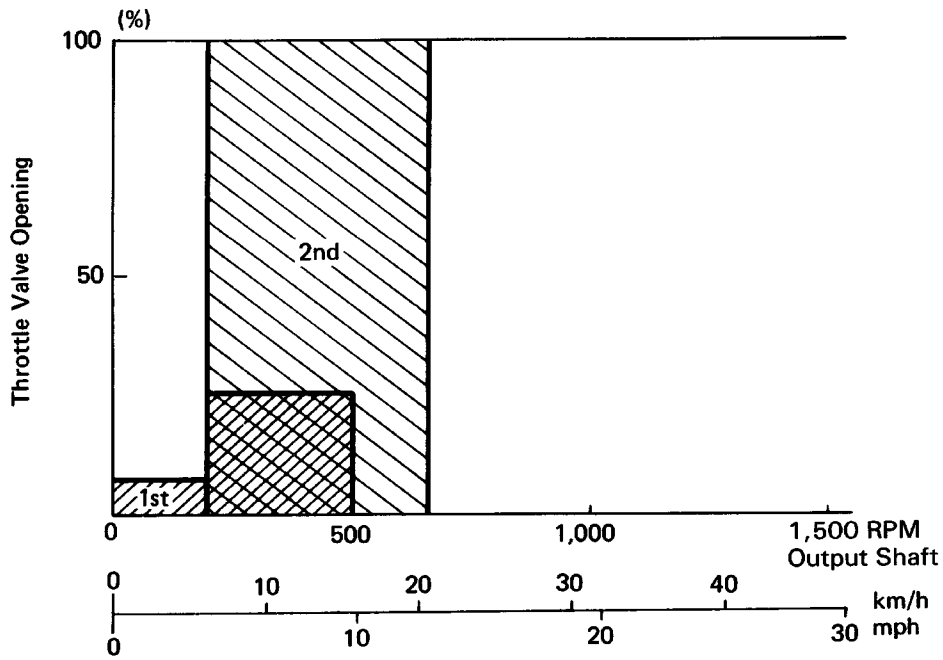

AT4663

**D Position: High-Low Shift Possibility Range**

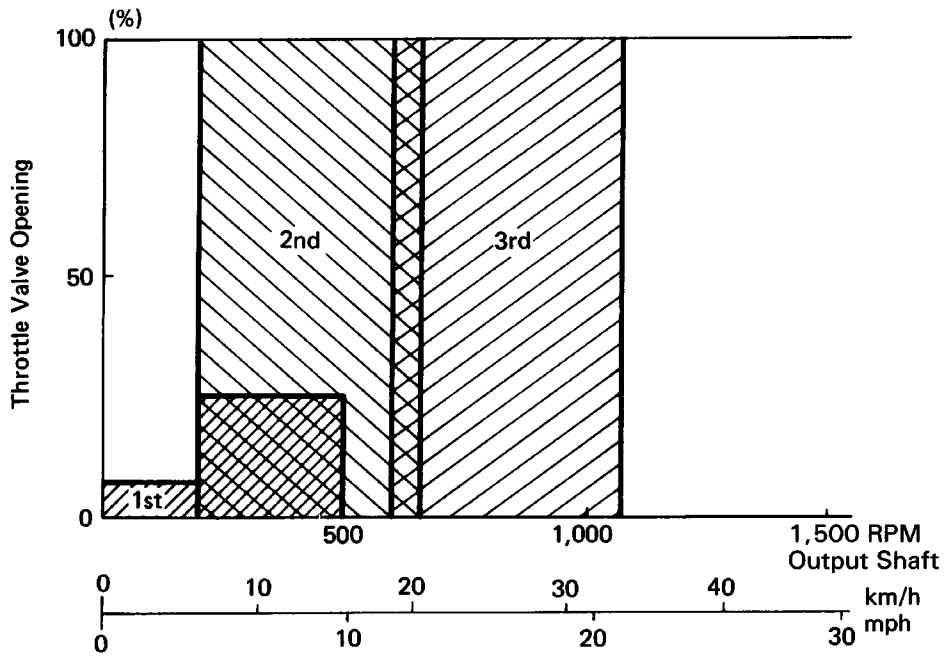

AT4664

Low-High Shift Possibility Range (L, 2, D Position)

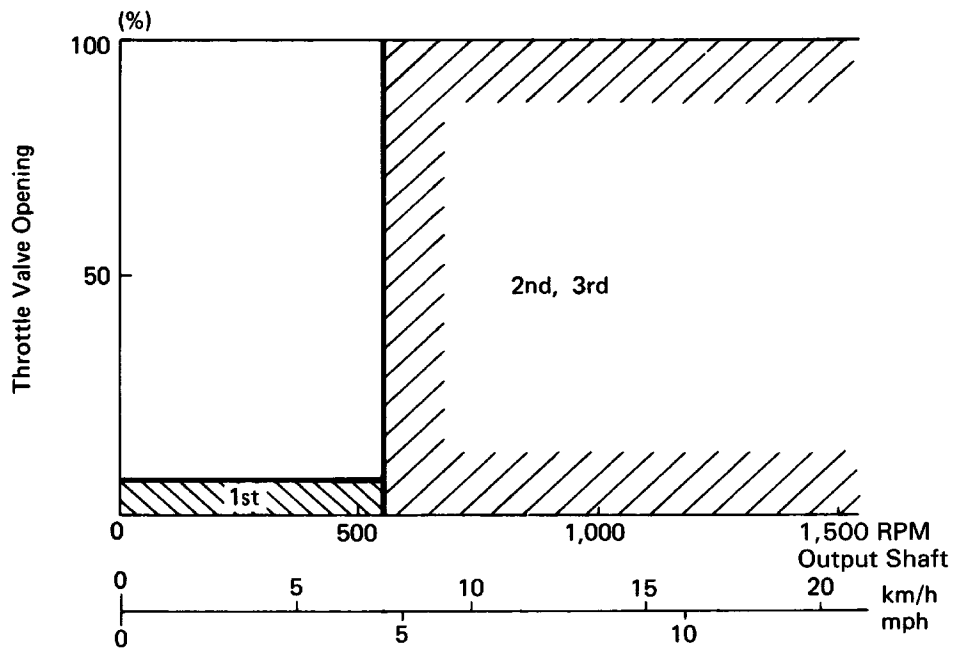

AT4665

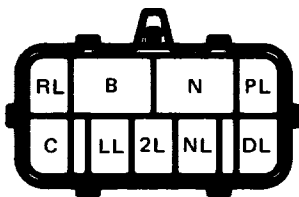

SH-9-2-A

Park Neutral Position Switch  
INSPECTION OF PARK/NEUTRAL  
POSITION SWITCH

Inspect that there is continuity between each terminals.

Terminal Shift Position	B	N	PL	RL	NL	DL	2L	LL	C
P	○—○	○—○	○—○	○—○	○—○	○—○	○—○	○—○	○—○
R				○—○	○—○	○—○	○—○	○—○	○—○
N	○—○	○—○			○—○	○—○	○—○	○—○	○—○
D						○—○	○—○	○—○	○—○
2							○—○	○—○	○—○
L								○—○	○—○

## ON-VEHICLE REPAIR

### Transmission Valve Body

#### REMOVAL OF VALVE BODY AND/OR SOLENOID VALVE

##### 1. CLEAN TRANSMISSION EXTERIOR

To prevent contamination, clean the exterior of the transmission.

##### 2. DRAIN TRANSMISSION FLUID

Remove the drain plug and drain the fluid into a suitable container.

##### 3. REMOVE FRONT STABILIZER BAR

(See page [SA-123](#))

##### 4. REMOVE FRONT PROPELLER SHAFT

(See page [PR-4](#))

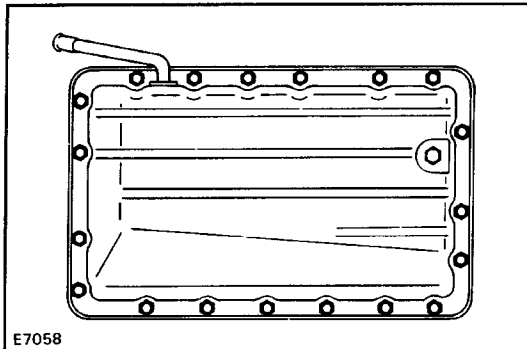

##### 5. REMOVE TRANSMISSION OIL PAN

(a) Remove the nineteen bolts.

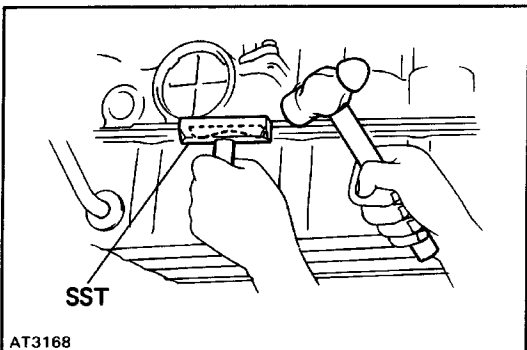

(b) Install the blade of SST between the transmission case and oil pan, cut off applied sealer.  
SST 09032-00100

**NOTICE:** Be careful not to damage the oil pan flange.

(c) Remove pan by lifting the transmission case.

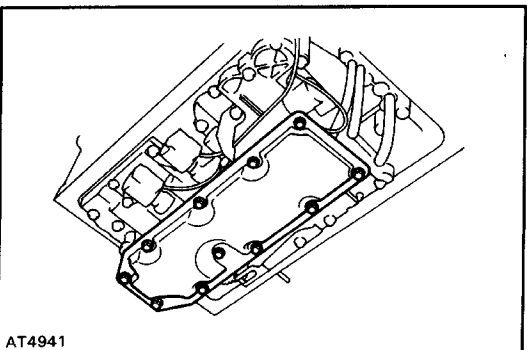

##### 6. REMOVE OIL STRAINER AND GASKETS

(a) Remove the eleven bolts holding the oil strainer to the oil strainer case.

(b) Remove the oil strainer and gasket.

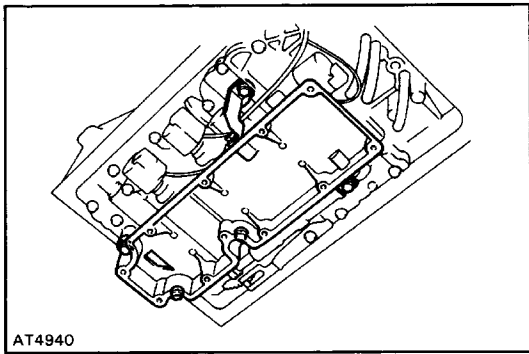

AT4940

- (c) Remove the five bolts and oil strainer case.
- (d) Remove the two gaskets from the case.

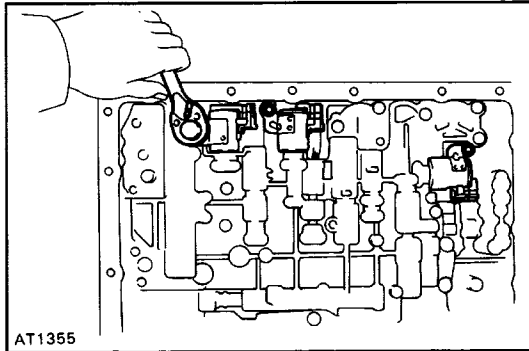

AT1355

### 7. WHEN REPLACING SOLENOIDS

- (a) Disconnect the connectors from the solenoids.
- (b) Remove the solenoid mounting bolts.
- (c) Remove the solenoids.

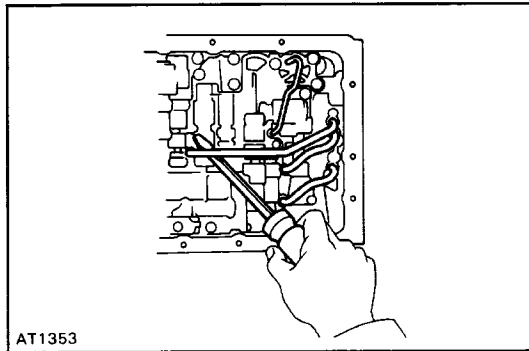

AT1353

### 8. REMOVE OIL TUBES

Pry up both tube ends with a large screwdriver and remove the three tubes.

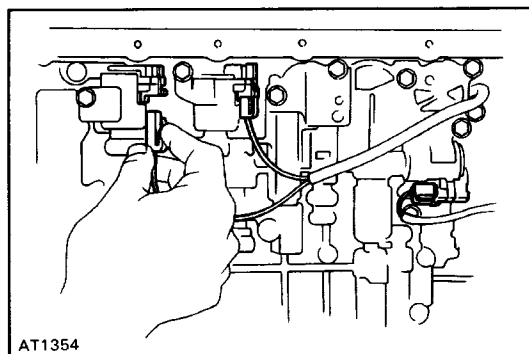

AT1354

### 9. DISCONNECT SOLENOID CONNECTORS

Disconnect the three connectors from No. 1, No. 2 and lock-up solenoids.

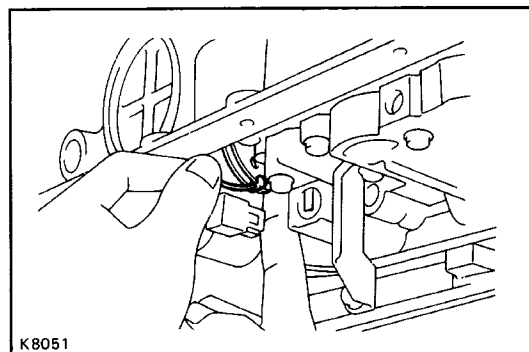

K8051

### 10. REMOVE VALVE BODY

- (a) Disconnect the throttle cable from the cam.

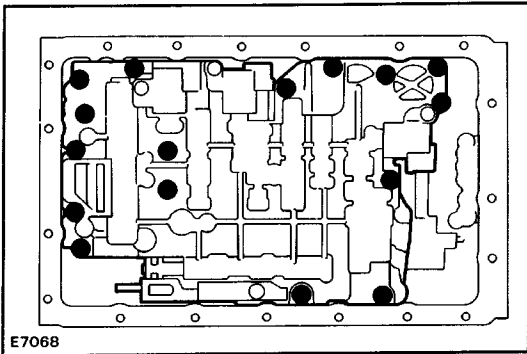

(b) Remove the sixteen bolts.

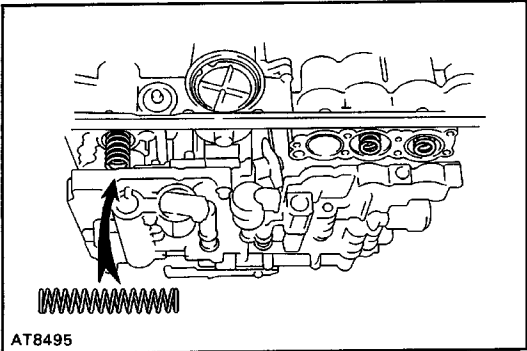

(c) Remove the two Co accumulator piston springs.  
 (d) Remove the valve body.

HINT: Be careful not to drop the check ball body and spring.

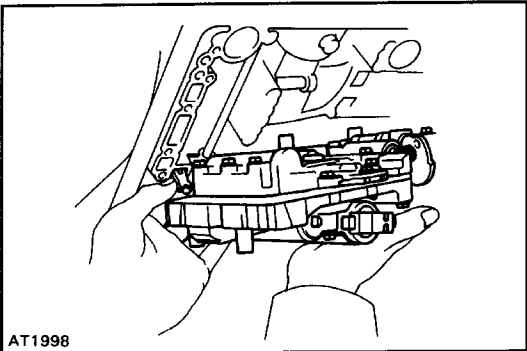

**INSTALLATION OF VALVE BODY AND/OR SOLENOID VALVE**

**1. INSTALL VALVE BODY**

(a) Install the valve body together the check ball body and spring.

HINT: Align the groove of the manual valve to the pin of the lever.

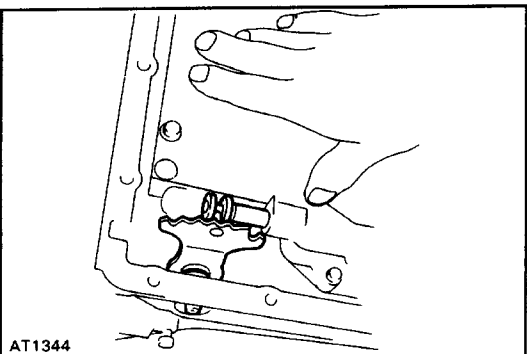

(b) Align the groove of the manual valve to the pin of the lever.

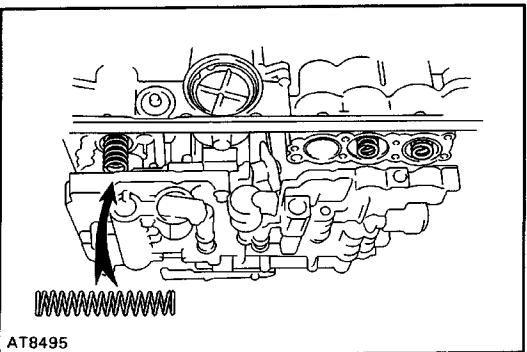

(c) Install the two Co accumulator piston springs.



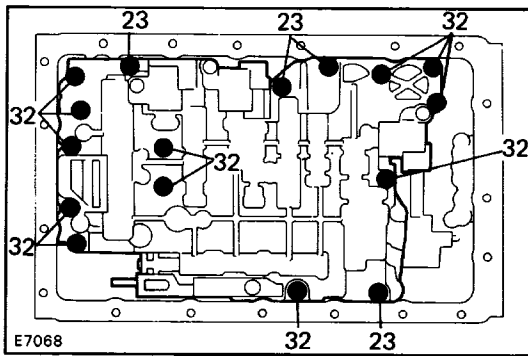

(d) Install the sixteen bolts.

HINT: Each bolt length (mm) is indicated in the figure.

**Torque: 10 N-m (0.00 kgf-cm, 7 ft-lbf)**

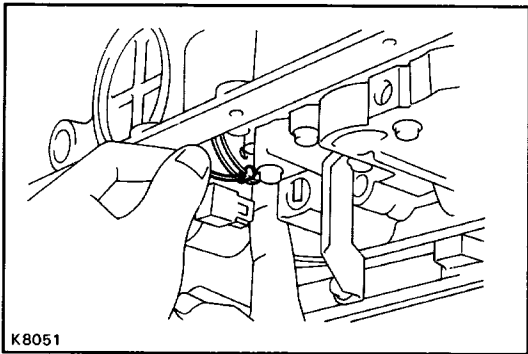

(e) Connect the throttle cable to the cam.

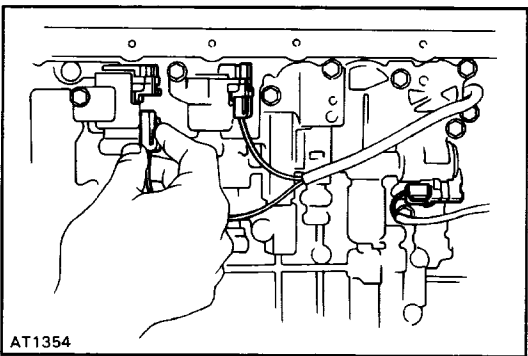

## 2. CONNECT CONNECTORS TO EACH SOLENOID

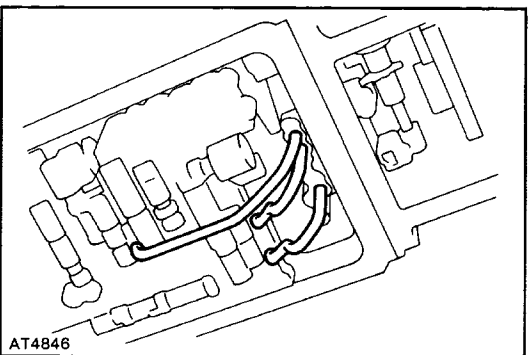

## 3. INSTALL OIL TUBES

Using a plastic hammer, install the three tubes into position shown in the figure.

**NOTICE: Be careful not to bend or damage the tubes.**

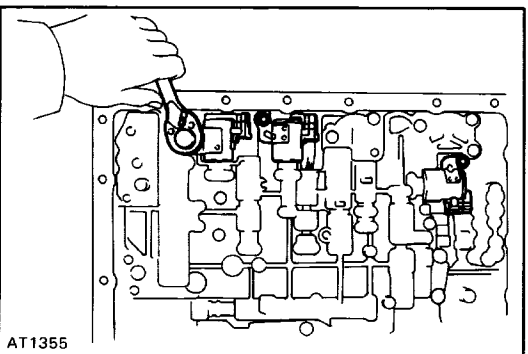

## 4. WHEN REPLACING SOLENOID

- (a) Install a new O-ring to the solenoid.
- (b) Install the solenoid and torque the bolt.

**Torque: 10 N-m (100 kgf-cm, 7 ft-lbf)**

- (c) Connect the connector to the solenoid.
- (d) Clamp the solenoid wire.

**5. INSTALL OIL STRAINER AND GASKETS**

(a) Install two new gaskets to the oil strainer case.

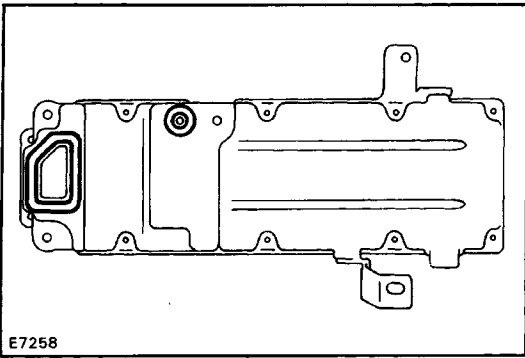

(b) Install the oil strainer case and torque the five bolts.

**Torque: 10 N-m (100 kgf-cm, 7 ft-lbf)**

HINT: Each bolt length (mm) is indicated in the figure.

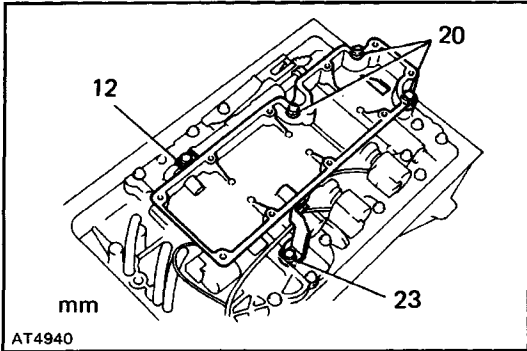

(c) Install a new gasket to the oil strainer case.

(d) Install the oil strainer and torque the eleven bolts.

**Torque: 6.9 N-m (70 kgf-cm, 61 in.-lbf)**

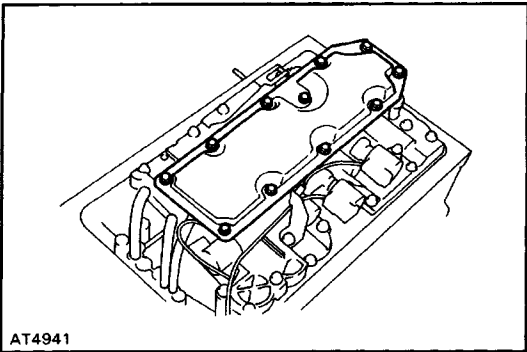

**6. INSTALL OIL PAN**

(a) Remove any packing material and be careful not to drop the oil on the contacting surfaces of the oil pan and transmission case.

(b) Clean contacting surfaces of any residual packing material using gasoline or alcohol.

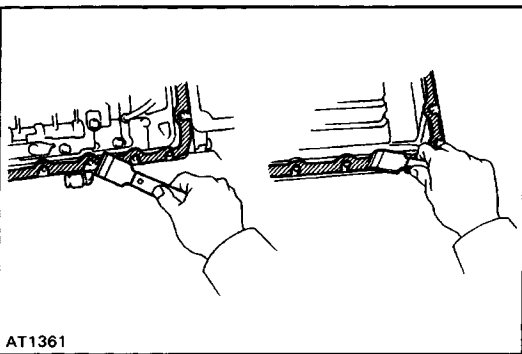

(c) Install the six magnets as shown in the figure.

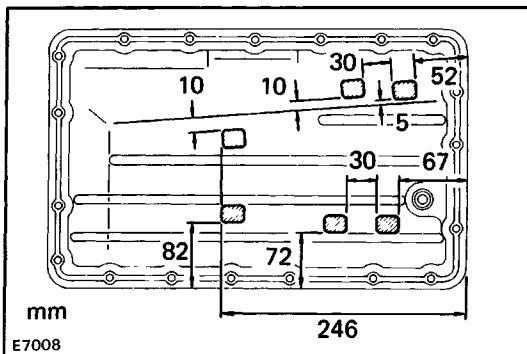

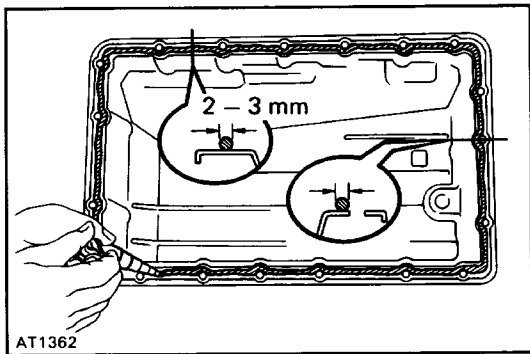

(d) Apply seal packing to the oil pan as shown in the figure.

Seal packing: Part No. 08826-00090, THREE BOND 1281 or equivalent

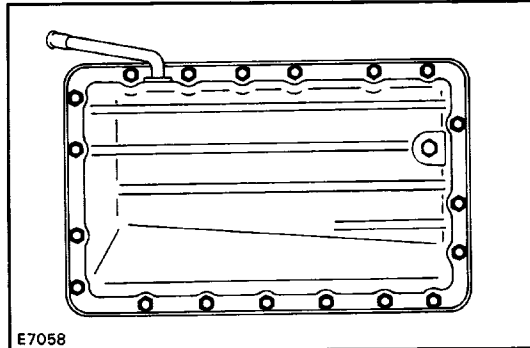

(e) Install and torque the nineteen bolts.

Torque: 7.4 N-m (75 kgf-cm, 61 in.·lbf)

#### 7. INSTALL OIL PAN DRAIN PLUG

Torque the drain plug.

Torque: 20 N-m (205 kgf-cm, 15 ft-lbf)

#### 8. INSTALL FRONT PROPELLER SHAFT

(See page [PR-4](#))

#### 9. INSTALL FRONT STABILIZER BAR

(See page [SA-123](#))

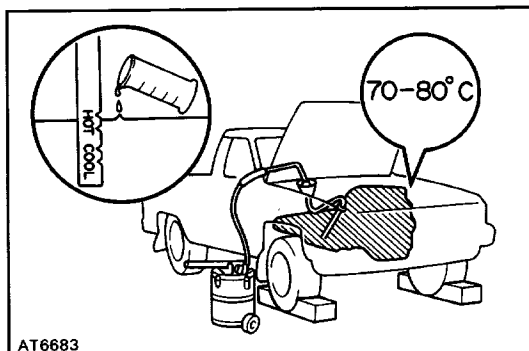

#### 10. FILL TRANSMISSION WITH ATF

(See page [AT-1 14](#))

**NOTICE:** Do not overfill.

Fluid type: ATF DEXRON<sup>®</sup> II

#### 11. CHECK FLUID LEVEL

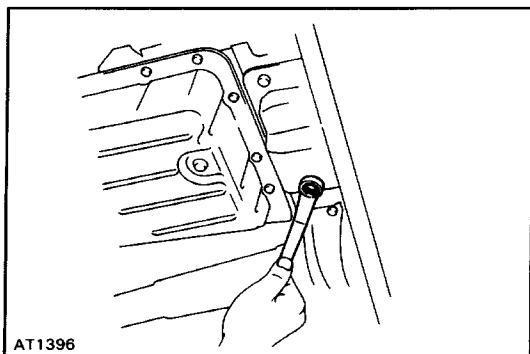

## Transfer Valve Body REMOVAL OF VALVE BODY AND/OR SOLENOID

### VALVE

#### 1. CLEAN TRANSFER EXTERIOR

To prevent contamination, clean the exterior of the transfer.

#### 2. DRAIN TRANSFER CASE FLUID

Remove the drain plug and drain fluid into a suitable container.

#### 3. SUPPORT TRANSMISSION

Using a transmission jack, support the transmission.

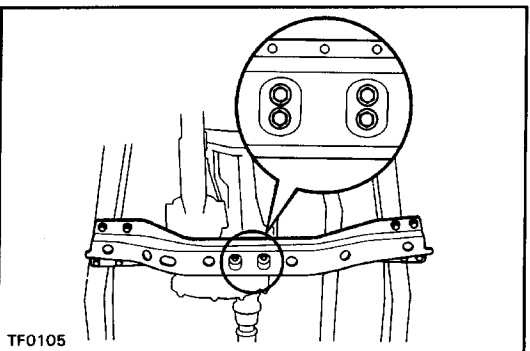
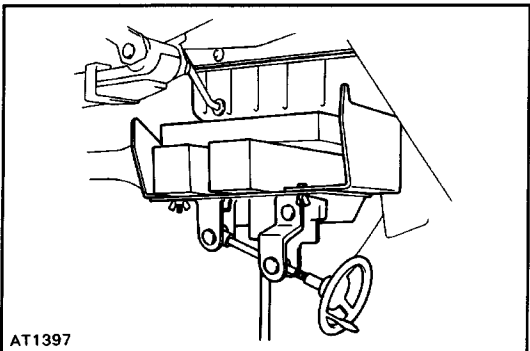

#### 4. REMOVE REAR SUPPORT MEMBER FROM SIDE FRAME

- (a) Remove the four bolts from the engine rear mounting.
- (b) Raise the transmission slightly with a jack.
- (c) Remove the eight bolts from the side frame and remove the rear support member.

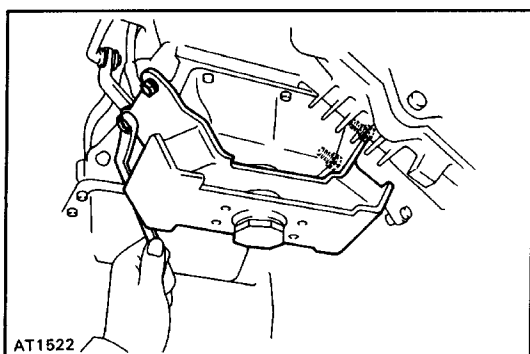

#### 5. REMOVE MEMBER BRACKET FROM TRANSFER

Remove the four bolts and member bracket from the transfer.

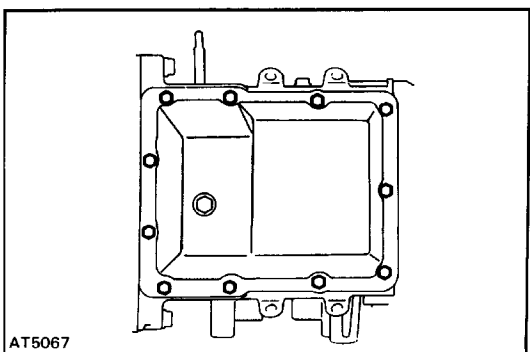

#### 6. REMOVE TRANSFER OIL PAN

- (a) Remove the eleven bolts.

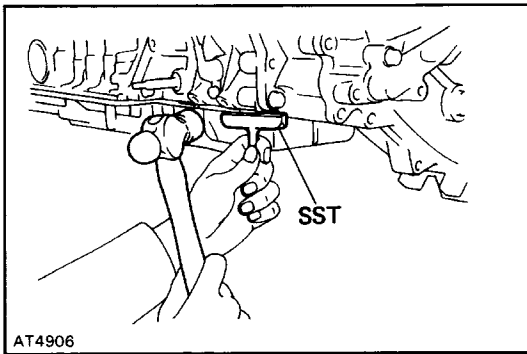

- (b) Install the blade of SST between the transfer case and oil pan, cut off applied sealer.

SST 09032-00100

**NOTICE:** Be careful not to damage the oil pan flange.

- (c) Remove the transfer oil pan.

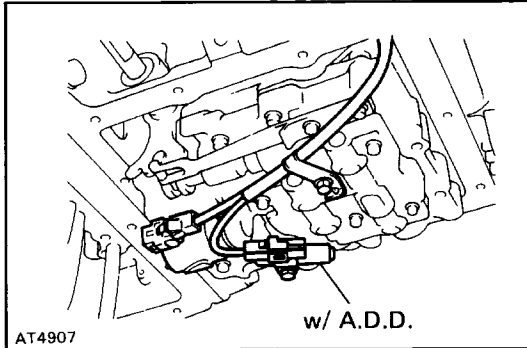

## 7. DISCONNECT SOLENOID CONNECTOR

Disconnect the connectors from No.4 solenoid and transfer pressure switch.

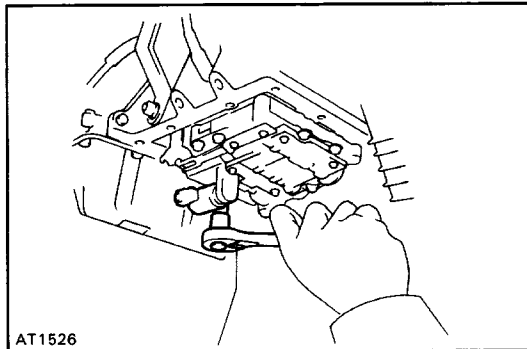

## 8. WHEN REPLACING SOLENOID

- (a) Remove the solenoid mounting bolt.  
 (b) Remove the solenoid.

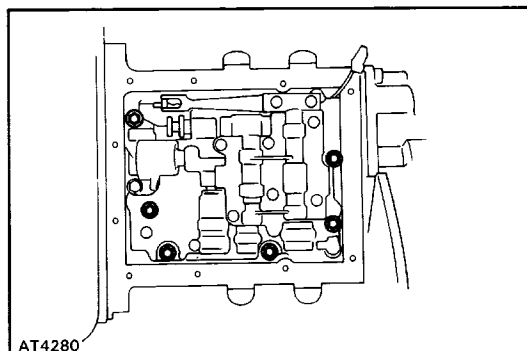

## 9. REMOVE VALVE BODY

Remove the six bolts and valve body.

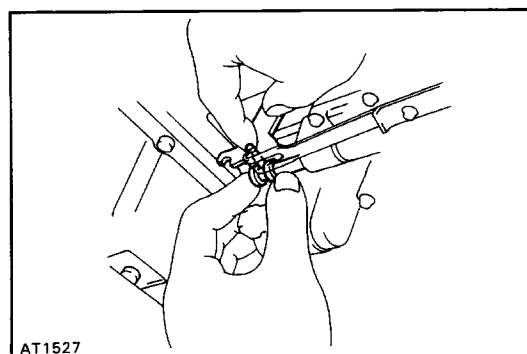

## INSTALLATION OF VALVE BODY AND/OR SOLENOID VALVE

### 1. INSTALL VALVE BODY

- (a) Align the manual valve lever with the manual valve.

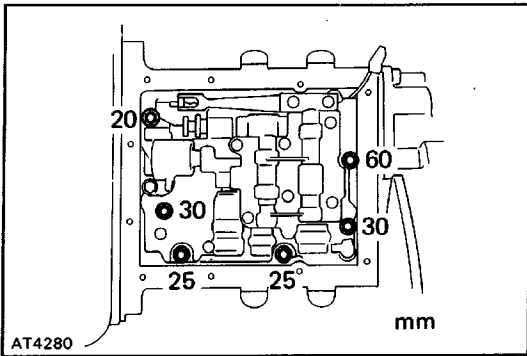

(b) Install the bolts as shown. Torque the bolts evenly.

**Torque: 10 N-m (100 kgf-cm, 7 ft-lbf)**

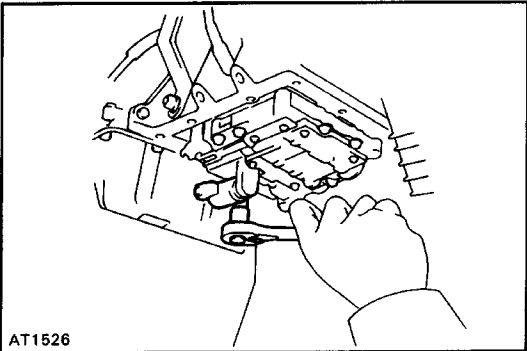

**2. WHEN REPLACING SOLENOID**

Install the solenoid and torque the bolt.

**Torque: 10 N-m (100 kgf-cm, 7 ft-lbf)**

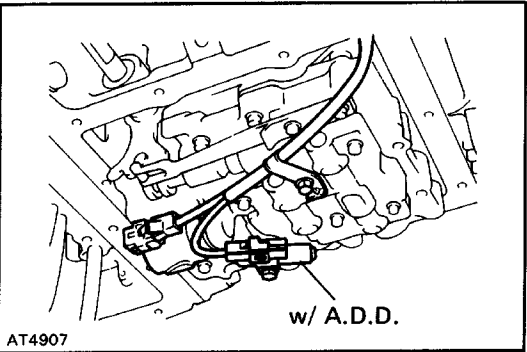

**3. CONNECT CONNECTOR TO SOLENOID**

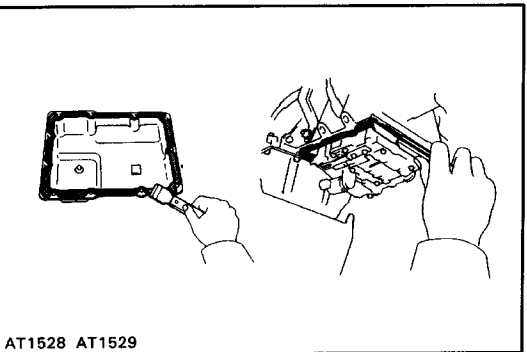

**4. INSTALL TRANSFER OIL PAN**

- (a) Remove any packing material and be careful not to drop the oil on the contacting surfaces of the oil pan and transfer case.
- (b) Clean contacting surfaces of any residual packing material, using gasoline or alcohol.

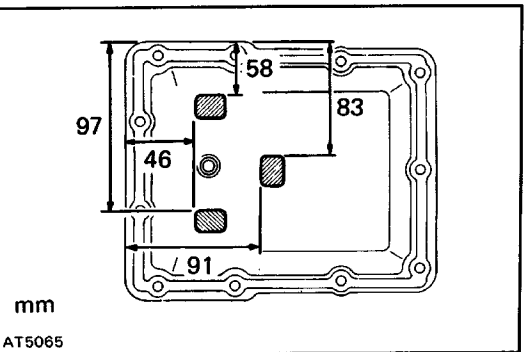

(c) Install the three magnets as shown in the figure.

AT5065

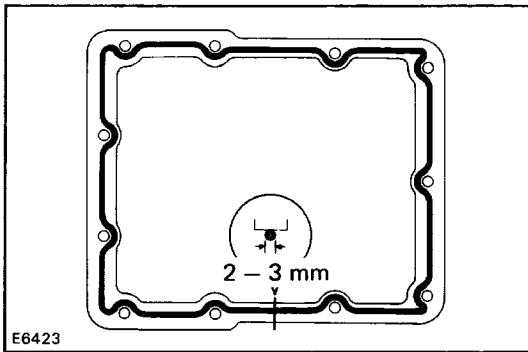

(d) Apply seal packing to the oil pan as shown in the figure.

**Seal packing: Part No. 08826-00090, THREE BOND 1281 or equivalent**

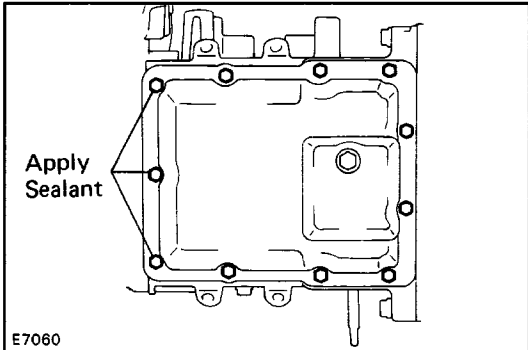

(e) Apply sealant to the threads of the three bolts.

**Sealant: Part No. 08833-00070, THREE BOND 1324 or equivalent**

(f) Install the oil pan and torque the eleven bolts.

**Torque: 7.4 N-m (75 kgf-cm, 65 in.-lbf)**

## 5. INSTALL DRAIN PLUG

**Torque the drain plug**

**Torque: 20 N-m (205 kgf-cm, 15 ft-lbf)**

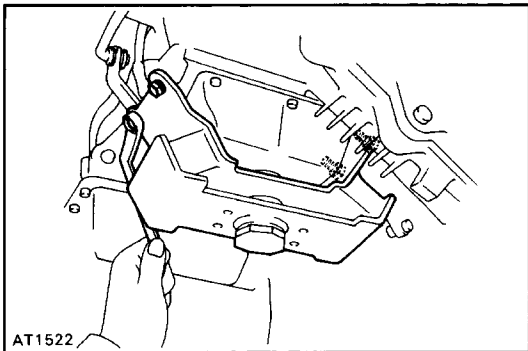

## 6. INSTALL MEMBER BRACKET TO TRANSFER

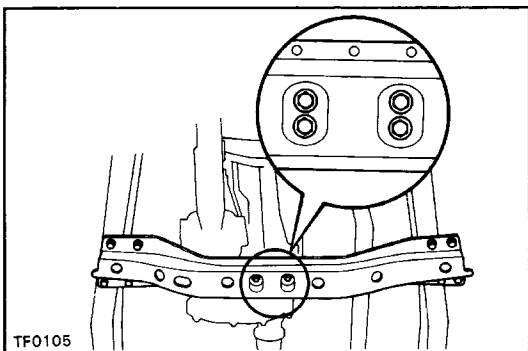

## 7. INSTALL REAR SUPPORT MEMBER

(a) Raise the transmission slightly with a jack.

(b) Install the rear support member to the side frame with the bolts. Torque the bolts.

**Torque: 95 N-m (970 kgf-cm, 70 ft-lbf)**

(c) Lower the transmission and transfer.

(d) Install the four mounting bolts to the engine rear mounting. Torque the bolts.

**Torque: 13 N-m (130 kgf-cm, 9 ft-lbf)**

## 8. REMOVE TRANSMISSION JACK

## 9. FILL TRANSMISSION WITH ATF

(See page [AT-115](#))

**NOTICE: Do not overfill.**

**Fluid type: ATF DEXRON®II**

## 10. CHECK FLUID LEVEL

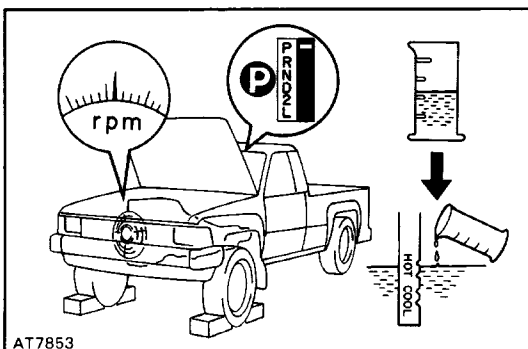

## Throttle Cable

### REMOVAL OF THROTTLE CABLE

**1. DISCONNECT THROTTLE CABLE FROM THROTTLE LINKAGE**

**2. DRAIN TRANSMISSION FLUID**

Remove the drain plug and drain the fluid into a suitable container.

**3. REMOVE FRONT STABILIZER BAR**

(See page SA-123)

**4. REMOVE FRONT PROPELLER SHAFT**

(See page PR-4)

**5. REMOVE TRANSMISSION OIL PAN**

(a) Remove the nineteen bolts.

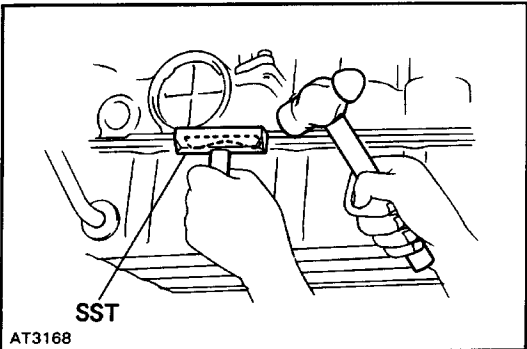
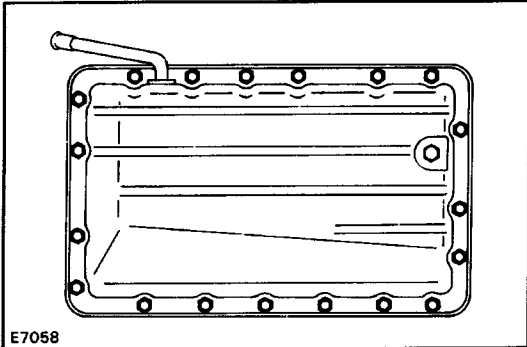

1bf Insert the blade of SST between the transmission case and oil pan, cut off applied sealer.  
SST 09032-00100

**NOTICE:** Be careful not to damage the oil pan flange.

(c) Remove pan by lifting the transmission case.

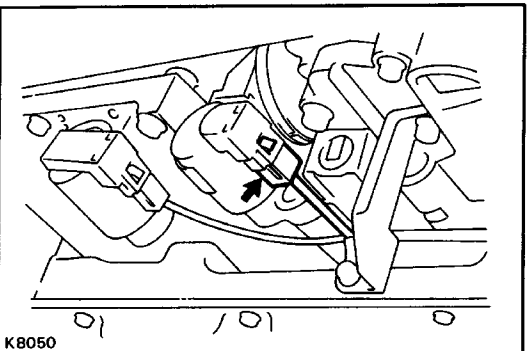

**6. DISCONNECT SOLENOID CONNECTOR**

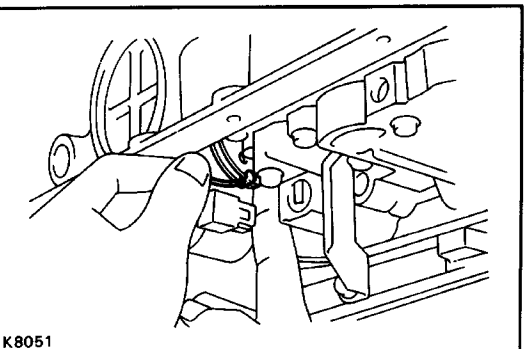

**7. DISCONNECT THROTTLE CABLE FROM VALVE BODY**



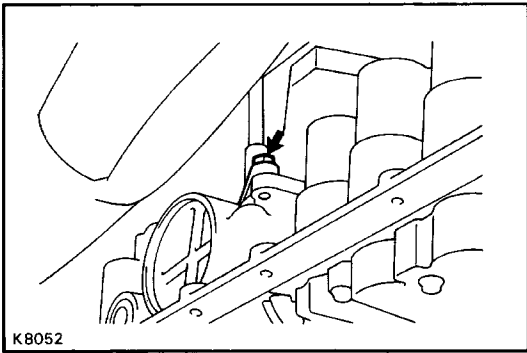

### 8. REMOVE THROTTLE CABLE

Remove the bolt and pull out the cable from the transmission case.

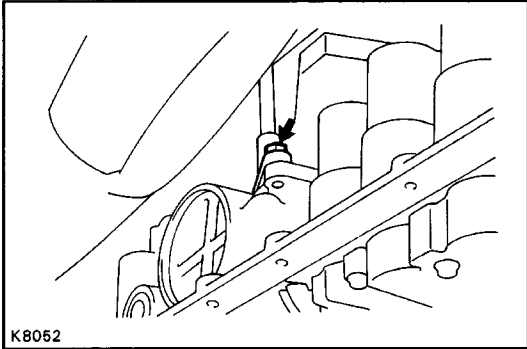

## INSTALLATION OF THROTTLE CABLE

### 1. INSTALL CABLE INTO TRANSMISSION CASE

- (a) Be sure to push it in all the way.
- (b) Install the bolt.

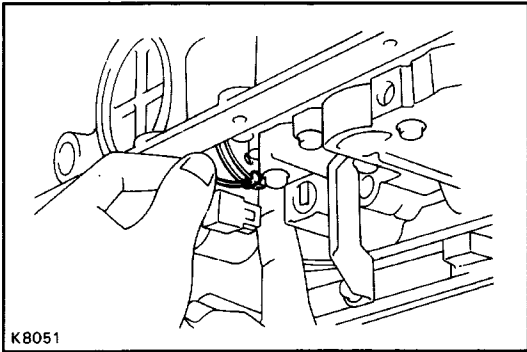

### 2. CONNECT THROTTLE CABLE TO VALVE BODY

Connect throttle cable to the cam.

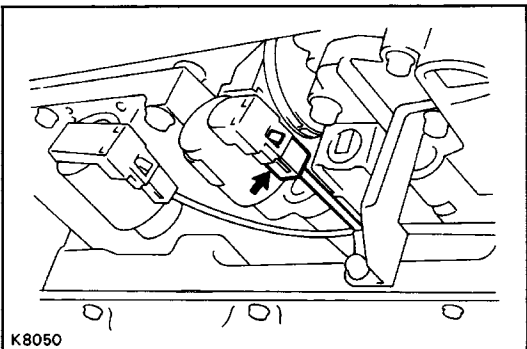

### 3. CONNECT SOLENOID CONNECTOR

### 4. INSTALL OIL PAN AND OIL PAN DRAIN PLUG

(See pages [AT-150](#) and [AT-151](#) )

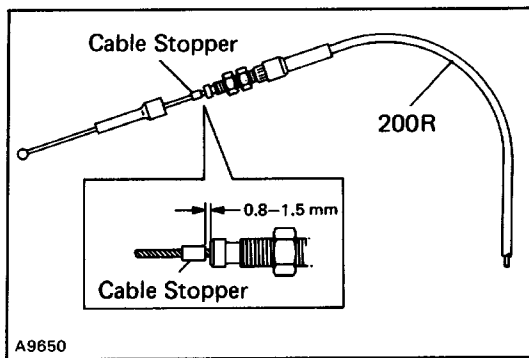

### 5. IF THROTTLE CABLE IS NEW, STAKE STOPPER ON INNER CABLE

HINT: New cable do not have a cable stopper staked.

- (a) Bend the cable so there is a radius of about 200 mm (7.87 in.).
- (b) Pull the inner cable lightly until a slight resistance is felt, and hold it.
- (c) Stake the stopper, 0.8–1.5 mm (0.031–0.059 in.) from the end of outer cable.

### 6. INSTALL FRONT PROPELLER SHAFT

(See page [PR-4](#))

### 7. INSTALL FRONT STABILIZER BAR

(See page [SA-123](#))

### 8. CONNECT THROTTLE CABLE TO THROTTLE LINKAGE

### 9. ADJUST THROTTLE CABLE

(See page [AT-116](#))

### 10. FILL TRANSMISSION WITH ATF

(See page [AT-115](#))

**NOTICE:** Do not overfill.

Fluid type: ATF DEXRON<sup>®</sup> II

### 11. CHECK FLUID LEVEL

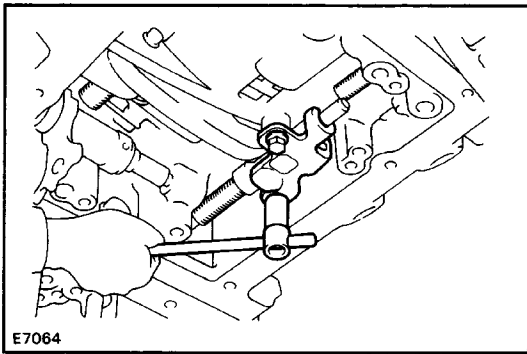

E7064

## Parking Lock Pawl

### REMOVAL OF PARKING LOCK PAWL

#### 1. REMOVE TRANSFER VALVE BODY

(See page [AT-151](#))

#### 2. REMOVE PARKING LOCK PAWL BRACKET

Remove the two bolts and bracket.

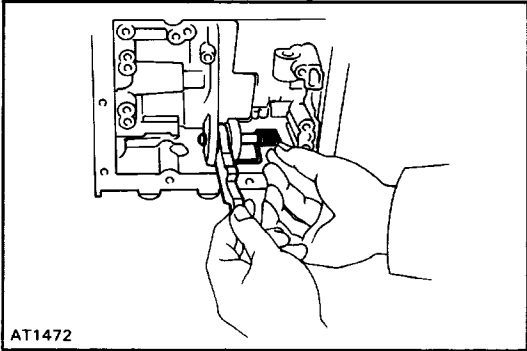

AT1472

#### 3. REMOVE SPRING, SHAFT AND PARKING LOCK PAWL

Remove the spring, shaft and parking lock pawl.

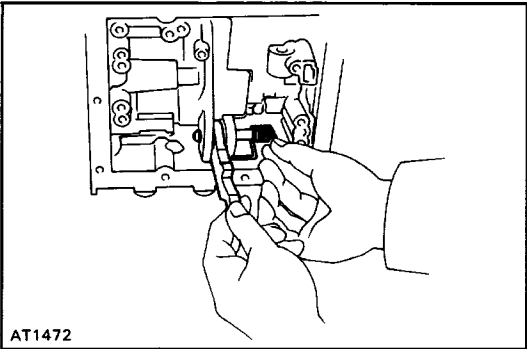

AT1472

## INSTALLATION OF PARKING LOCK PAWL

#### 1. INSTALL PARKING LOCK PAWL, SHAFT AND SPRING

Install the parking lock pawl, shaft and spring.

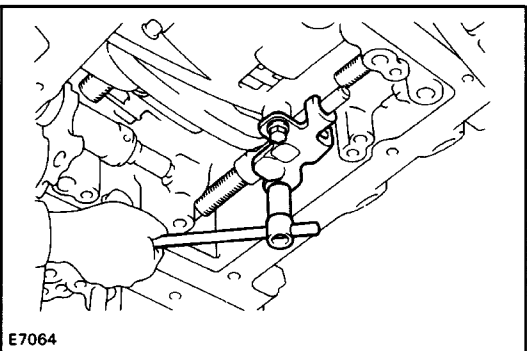

E7064

#### 2. INSTALL PARKING LOCK PAWL BRACKET

- (a) Install two bolts finger tight.
- (b) Check that the parking lock pawl operates smoothly.
- (c) Torque the bolts.

Torque: 6.9 N-m (70 kgf-cm, 61 in.·lbf)

#### 3. INSTALL TRANSFER VALVE BODY

(See page [AT-152](#))

# REMOVAL AND INSTALLATION OF TRANSMISSION

Remove and install the parts as shown.

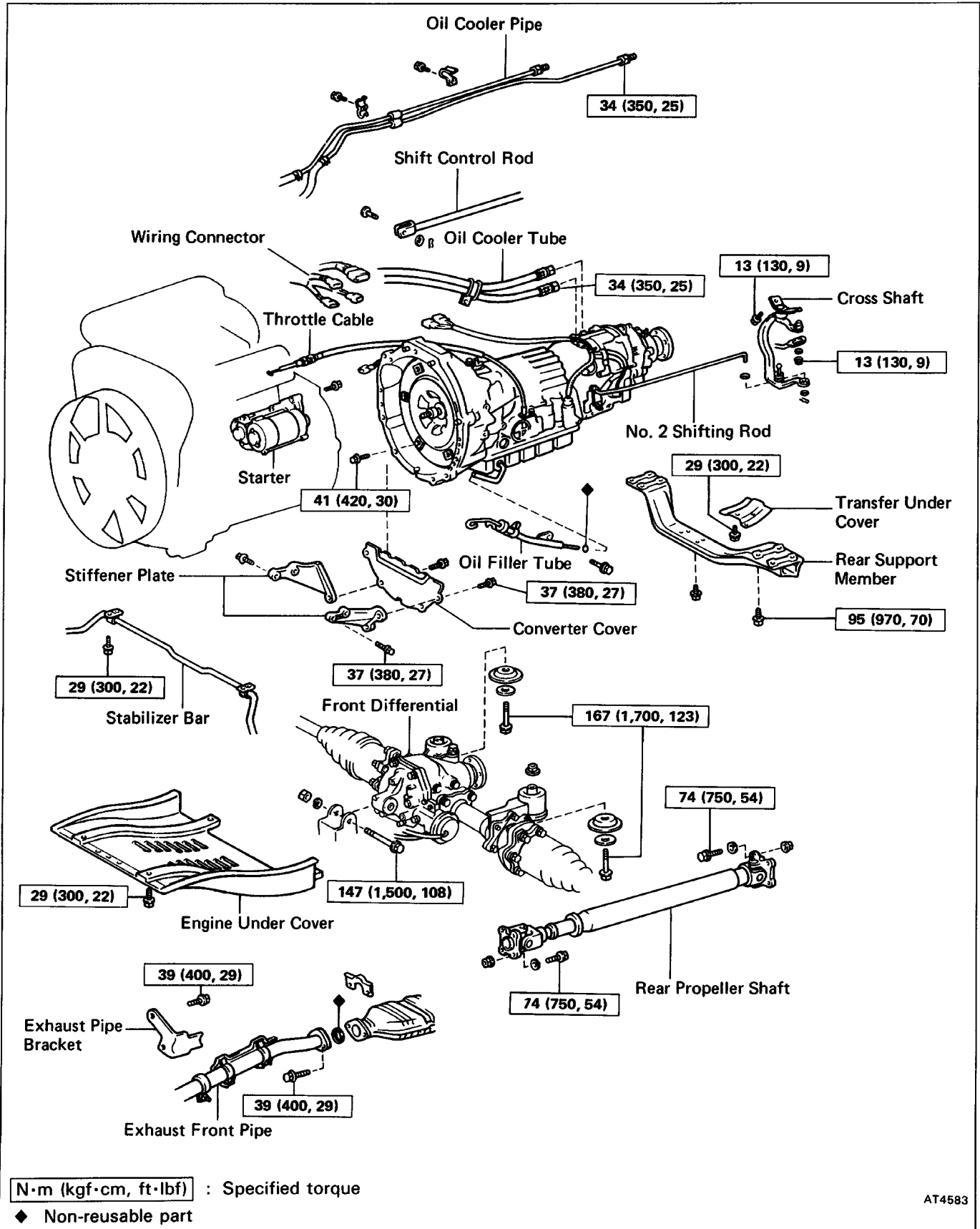

(Cont'd)

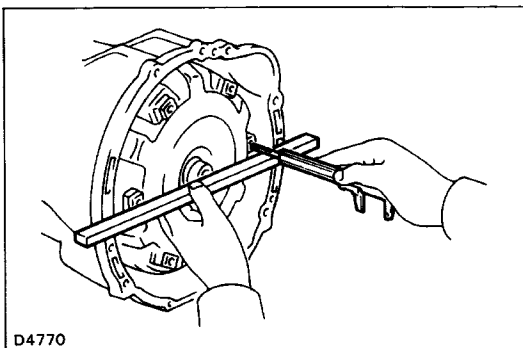
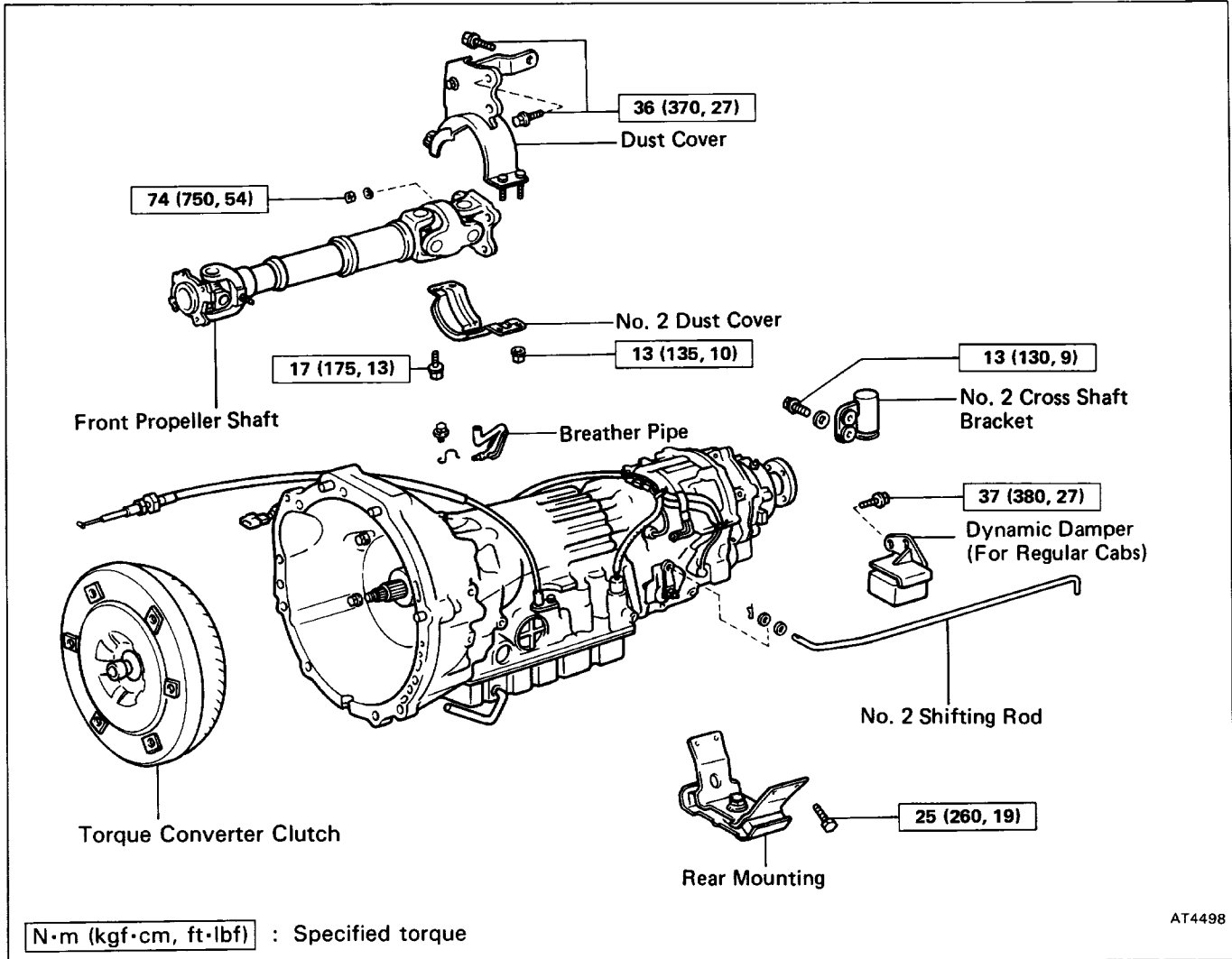
**(MAIN POINT OF INSTALLATION)****1. CHECK TORQUE CONVERTER CLUTCH INSTALLATION**

Using calipers and a straight edge, measure from the installed surface of the torque converter clutch to the front surface of the transmission housing.

Correct distance: 18.0 mm (0.709 in.)

If the distance is less than the standard, check for an improper installation.

**2. ADJUST TRANSMISSION THROTTLE CABLE**

(See page [AT-116](#))

**3. FILL TRANSMISSION WITH ATF AND CHECK FLUID LEVEL**

Fluid type: ATF DEXRON® II

**NOTICE:** Do not overfill.

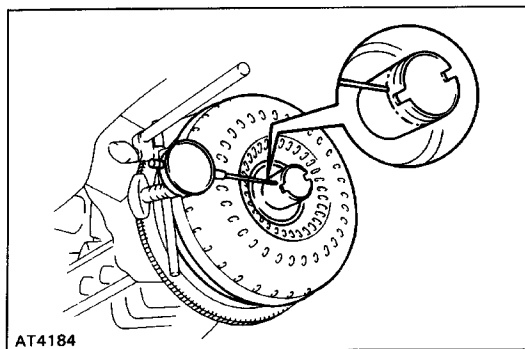
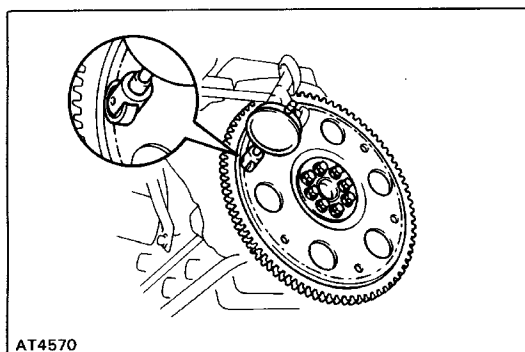
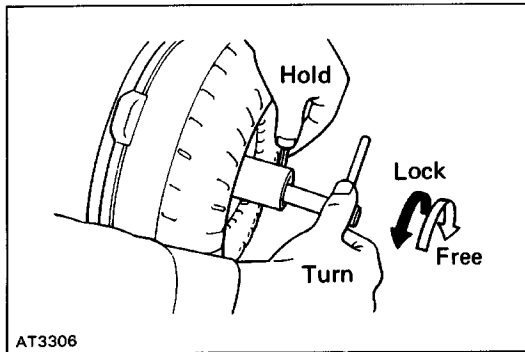
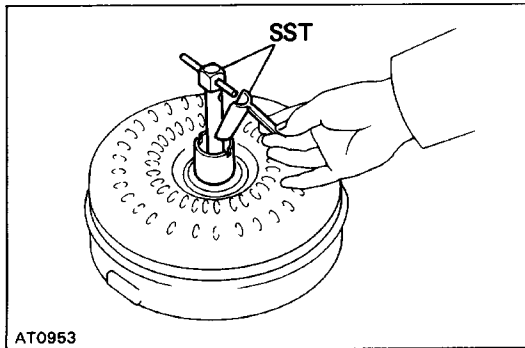
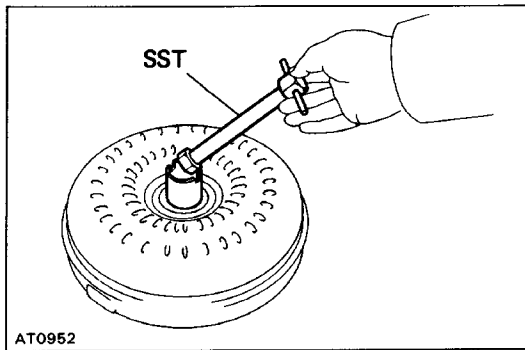

# TORQUE CONVERTER CLUTCH AND DRIVE PLATE

## INSPECTION OF TORQUE CONVERTER CLUTCH AND DRIVE PLATE

### 1. INSPECT ONE-WAY CLUTCH

- (a) Install SST into the inner race of the one-way clutch.  
SST 09350-30020 (09351-32010)
- (b) Install SST so that it fits in the notch of the converter hub and outer race of the one-way clutch.  
SST 09350-30020 (09351-32020)
- (c) With the torque converter clutch standing on its side, the clutch locks when turned counterclockwise, and rotates freely and smoothly clockwise.  
If necessary, clean the converter and retest the clutch.  
Replace the converter if the clutch still fails the test.

### 2. MEASURE DRIVE PLATE RUNOUT AND INSPECT RING GEAR

Set up a dial indicator and measure the drive plate runout.

If runout exceeds 0.20 mm (0.0079 in.) or if the ring gear is damaged, replace the drive plate. If installing a new drive plate, note the orientation of spacers and tighten the bolts.

**Torque: 83 N-m (850 kgf-cm, 61 ft-lbf)**

### 3. MEASURE TORQUE CONVERTER CLUTCH SLEEVE RUNOUT

- (a) Temporarily mount the torque converter clutch to the drive plate. Set up a dial indicator.  
If runout exceeds 0.30 mm (0.0118 in.), try to correct by reorienting the installation of the converter. If excessive runout cannot be corrected, replace the torque converter clutch.

**HINT:** Mark the position of the converter to ensure correct installation.

- (b) Remove the torque converter clutch.

MEMO

# A340F Automatic Transmission



# DESCRIPTION

## GENERAL

The A340F automatic transmission is a four-speed automatic transmission with mechanically controlled 4WD transfer, developed with the aim of producing an easy-driving 4WD vehicle. The transmission section has fundamentally the same construction as the A340E automatic transmission mounted in the TRUCK 2WD. The operation of these is fully controlled by the ECM.

The A340F transmission is mainly composed of the torque converter clutch, the overdrive (hereafter called O/D) planetary gear unit, 3-speed planetary gear unit, the hydraulic control system and the electronic control system.

**Sectional View**

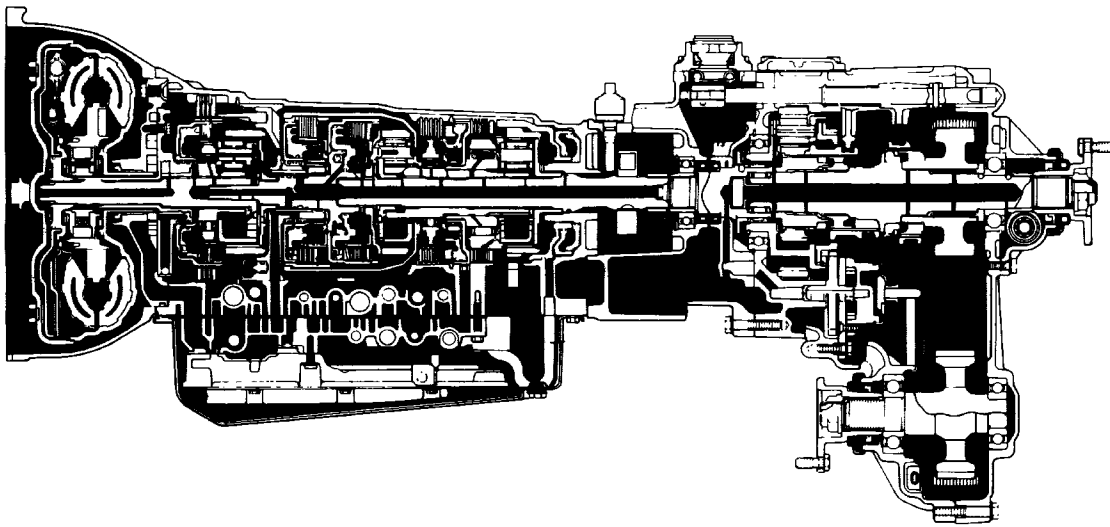

AT5774

# General Specifications

Type of Transmission		A340F	
Type of Engine		22R-E	
Torque Converter Clutch	Stall Torque Ratio		2.3 : 1
	Lock-Up Mechanism		Equipped
Gear Ratio	1 st Gear		2.804
	2nd Gear		1.531
	3rd Gear		1.000
	O/D Gear		0.705
	Reverse Gear		2.393
Plates (Disc/Plate)	C <sub>0</sub>	O/D Direct Clutch	1/1
	C <sub>1</sub>	Forward Clutch	4/4
	C <sub>2</sub>	Direct Clutch	3/3
	B <sub>2</sub>	2nd Brake	4/4
	B <sub>3</sub>	1 st & Reverse Brake	5/5
	B <sub>0</sub>	O/D Brake	3/2
ATF	Type		ATF DEXRON® II
	Capacity litter (US qts, Imp. qts)	Total	7.6 (8.0, 6.7)
		Drain and Refill	2.0 (2.1, 1.8)

# OPERATION

## Mechanical Operation

### OPERATING CONDITIONS

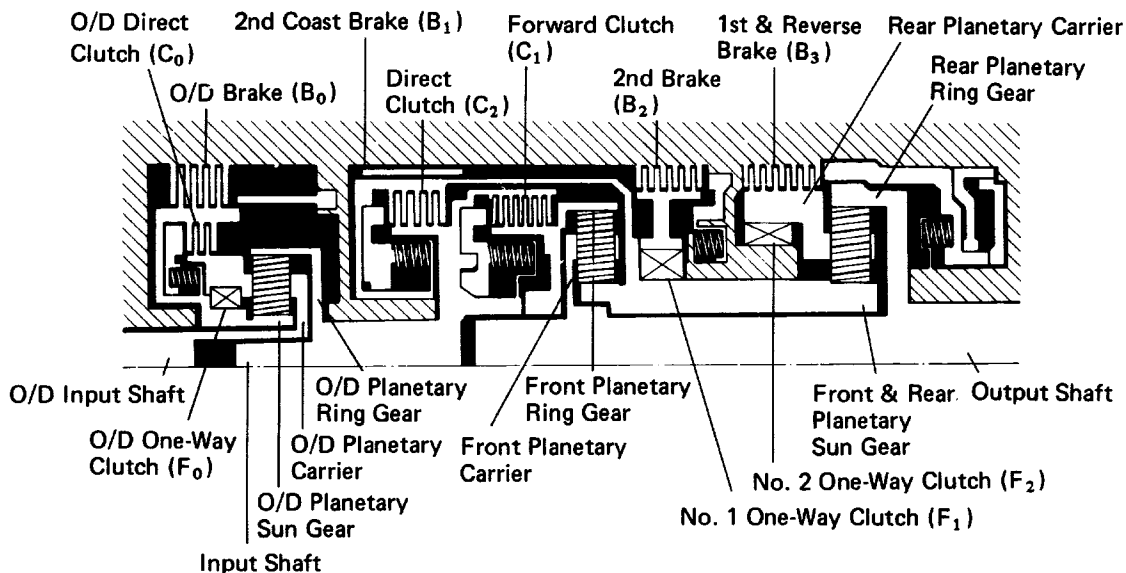

AT2157

○ ..... Operating

Shift lever position	Gear position	C <sub>0</sub>	C <sub>1</sub>	C <sub>2</sub>	B <sub>0</sub>	B <sub>1</sub>	B <sub>2</sub>	B <sub>3</sub>	F <sub>0</sub>	F <sub>1</sub>	F <sub>2</sub>
P	Parking	○									
R	Reverse	○		○				○	○		
N	Neutral	○									
D	1st	○	○						○		○
	2nd	○	○				○		○	○	
	3rd	○	○	○			○		○		
	O/D		○	○	○		○				
2	1st	○	○						○		○
	2nd	○	○			○	○		○	○	
	3rd	○	○	○			○		○		
L	1st	○	○					○	○		○
	* 2nd	○	○			○	○		○	○	

\* Down-shift only in the L position and 2nd gear—no up-shift.

# FUNCTION OF COMPONENTS

NOMENCLATURE	OPERATION
O/D Direct Clutch (Co)	Connects overdrive sun gear and overdrive carrier
O/D Brake (Bo)	Prevents overdrive sun gear from turning either clockwise or counterclockwise
O/D One-Way Clutch (Fo)	When transmission is being driven by engine, connects overdrive sun gear and overdrive carrier
Forward Clutch (C1)	Connects input shaft and front planetary ring gear
Direct Clutch (C2)	Connects input shaft and front & rear planetary sun gear
2nd Coast Brake (B1)	Prevents front & rear planetary sun gear from turning either clockwise or counterclockwise
2nd Brake (B2)	Prevents outer race of F, from turning either clockwise or counterclockwise, thus preventing front & rear planetary sun gear from turning counterclockwise
1 st & Reverse Brake (B3)	Prevents rear planetary carrier from turning either clockwise or counterclockwise
No. 1 One-Way Clutch (F1)	When B2 is operating, prevents front & rear planetary sun gear from turning counterclockwise
No.2 One-Way Clutch 1F21	Prevents rear planetary carrier from turning counterclockwise

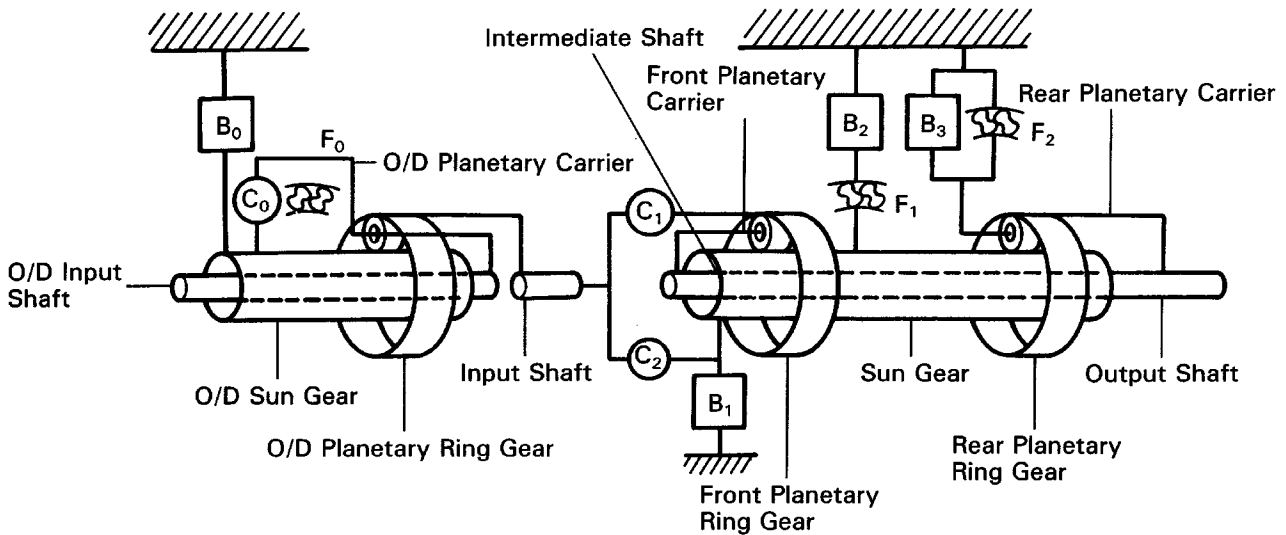

002857

## FUNCTION OF COMPONENTS (Cont'd)

The conditions of operation for each gear position are shown in the following illustrations:

**D or 2 Position 1st Gear**

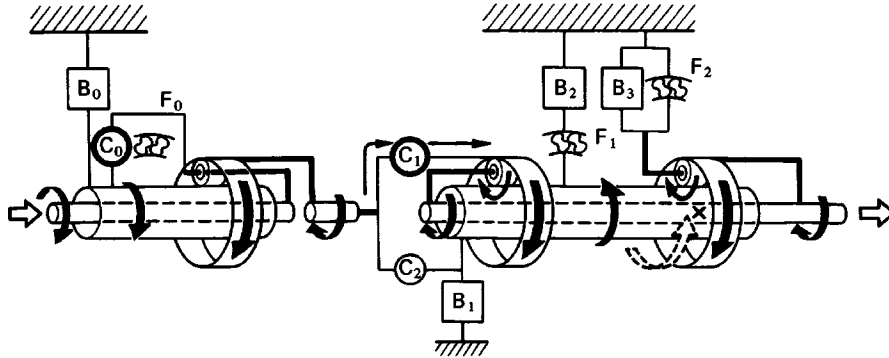

AT6675

**D Position 2nd Gear**

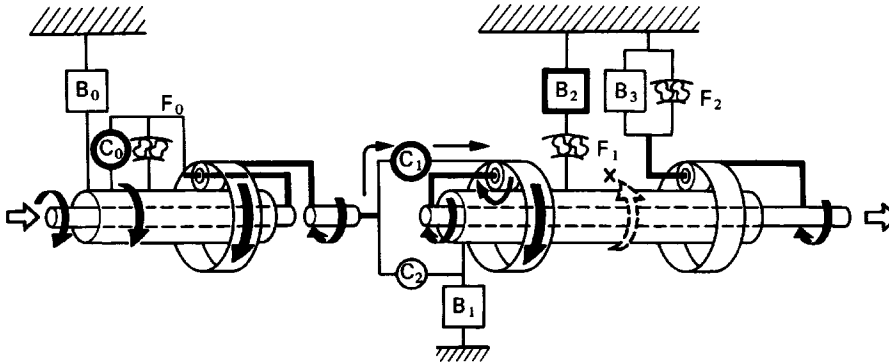

AT6676

**D or 2 Position 3rd Gear**

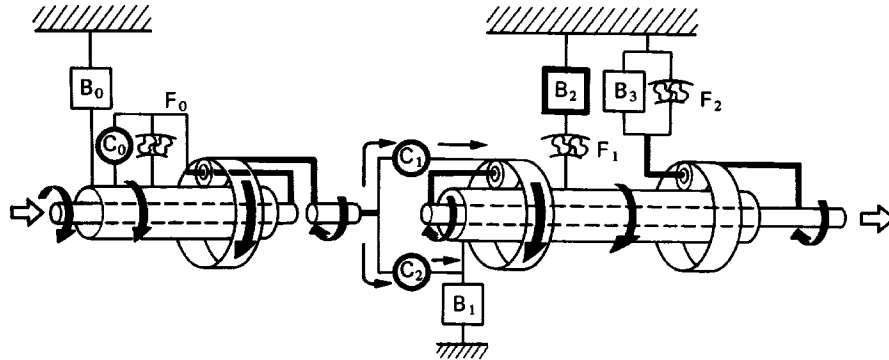

AT6677

**D Position O/D**

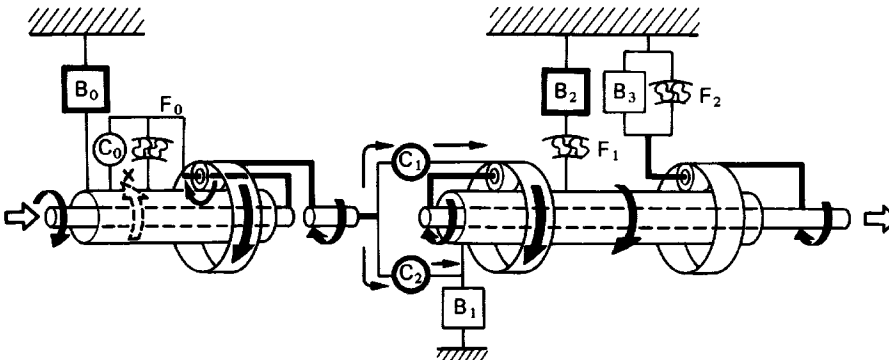

AT6678

# FUNCTION OF COMPONENTS (Cont'd)

**2 or L Position Gear**

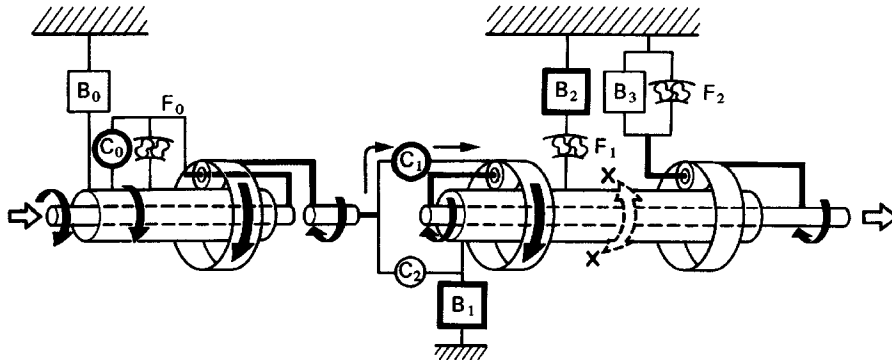

AT6679

**L Position 1st Gear**

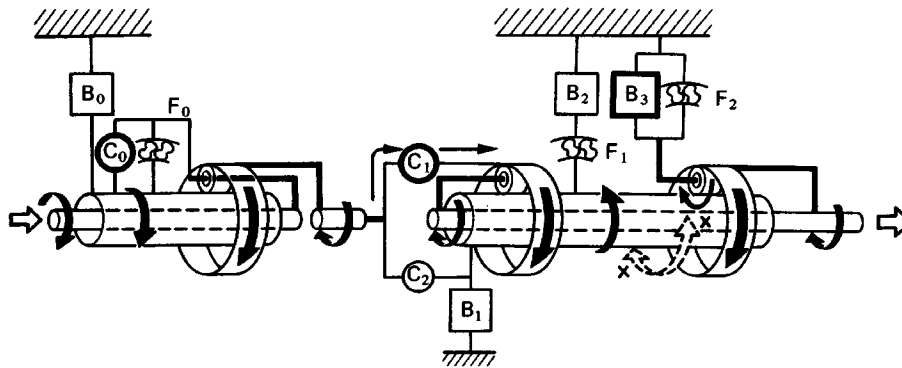

AT6680

**R Position Reverse Gear**

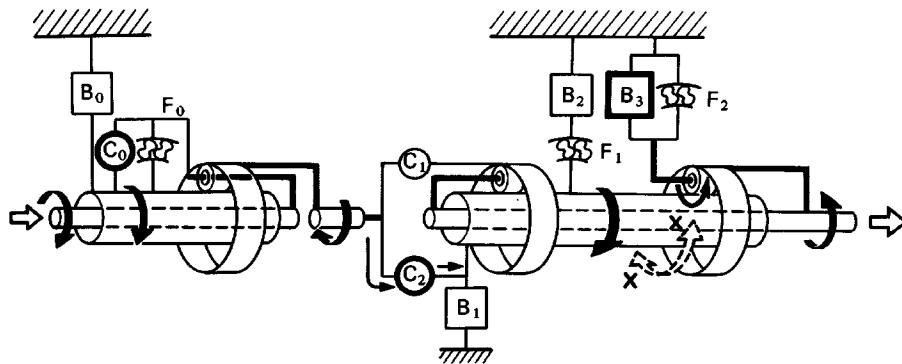

AT6681

## HYDRAULIC CONTROL SYSTEM

The hydraulic control system is composed of the oil pump, the valve body, the solenoid valves, and the clutches and brakes, as well as the fluid passages which connect all of these components. Based on the hydraulic pressure created by the oil pump, the hydraulic control system governs the hydraulic pressure acting on the torque converter clutch, clutches and brakes in accordance with the vehicle driving conditions.

There are three solenoid valves on the valve body. These solenoid valves are turned on or off by signals from the ECM to operate the shift valves. These shift valves then switch the fluid passages so that fluid goes to the torque converter clutch and planetary gear units.

(Except for the solenoid valves, the hydraulic control system of the electronic controlled transmission is basically the same as that of the fully hydraulic controlled automatic transmission.)

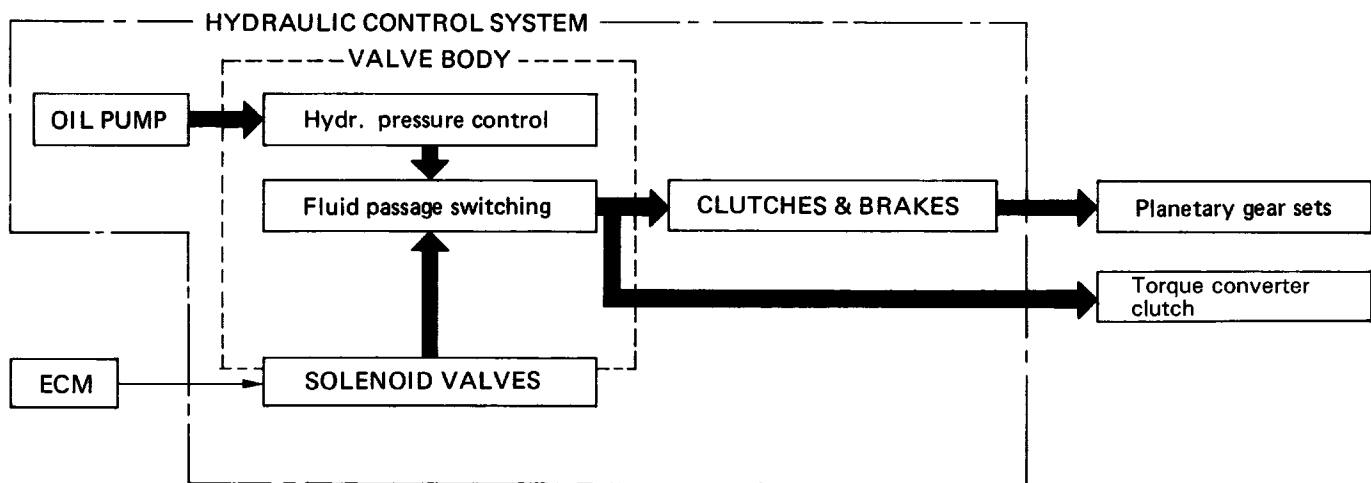

- **LINE PRESSURE**

Line pressure is the most basic and important pressure used in the automatic transmission, because it is used to operate all of the clutches and brakes in the transmission.

If the primary regulator valve does not operate correctly, line pressure will be either too high or too low. Line pressure that is too high will lead to shifting shock and consequent engine power loss due to the greater effort required of the oil pump; line pressure that is too low will cause slippage of clutches and brakes, which will, in extreme cases, prevent the vehicle from moving. Therefore, if either of these problems are noted, the line pressure should be measured to see if it is within standard.

- **THROTTLE PRESSURE**

Throttle pressure is always kept in accordance with the opening angle of the engine throttle valve. This throttle pressure acts on the primary regulator valve and, accordingly, line pressure is regulated in response to the throttle valve opening.

In the fully hydraulic controlled automatic transmission, throttle pressure is used for regulating line pressure and as signal pressure for up-shift and down-shift of the transmission. In the electronic controlled transmission, however, throttle pressure is used only for regulating line pressure. Consequently, improper adjustment of the transmission throttle cable may result in a line pressure that is too high or too low. This, in turn, will lead to shifting shock or clutch and brake slippage.

## ELECTRONIC CONTROL SYSTEM

The electronic control system, which controls the shift points and the operation of the lock-up clutch, is composed of the following three parts:

### 1. Sensors

These sensors sense the vehicle speed, throttle opening and other conditions and send these data to the ECM in the form of electrical signals.

### 2. ECM

The ECM determines the shift and lock-up timing based upon the signals from sensors, and controls the solenoid valves of the hydraulic control unit accordingly.

### 3. Actuators

These are three solenoid valves that control hydraulic pressure acting on the hydraulic valves to control shifting and lock-up timing.

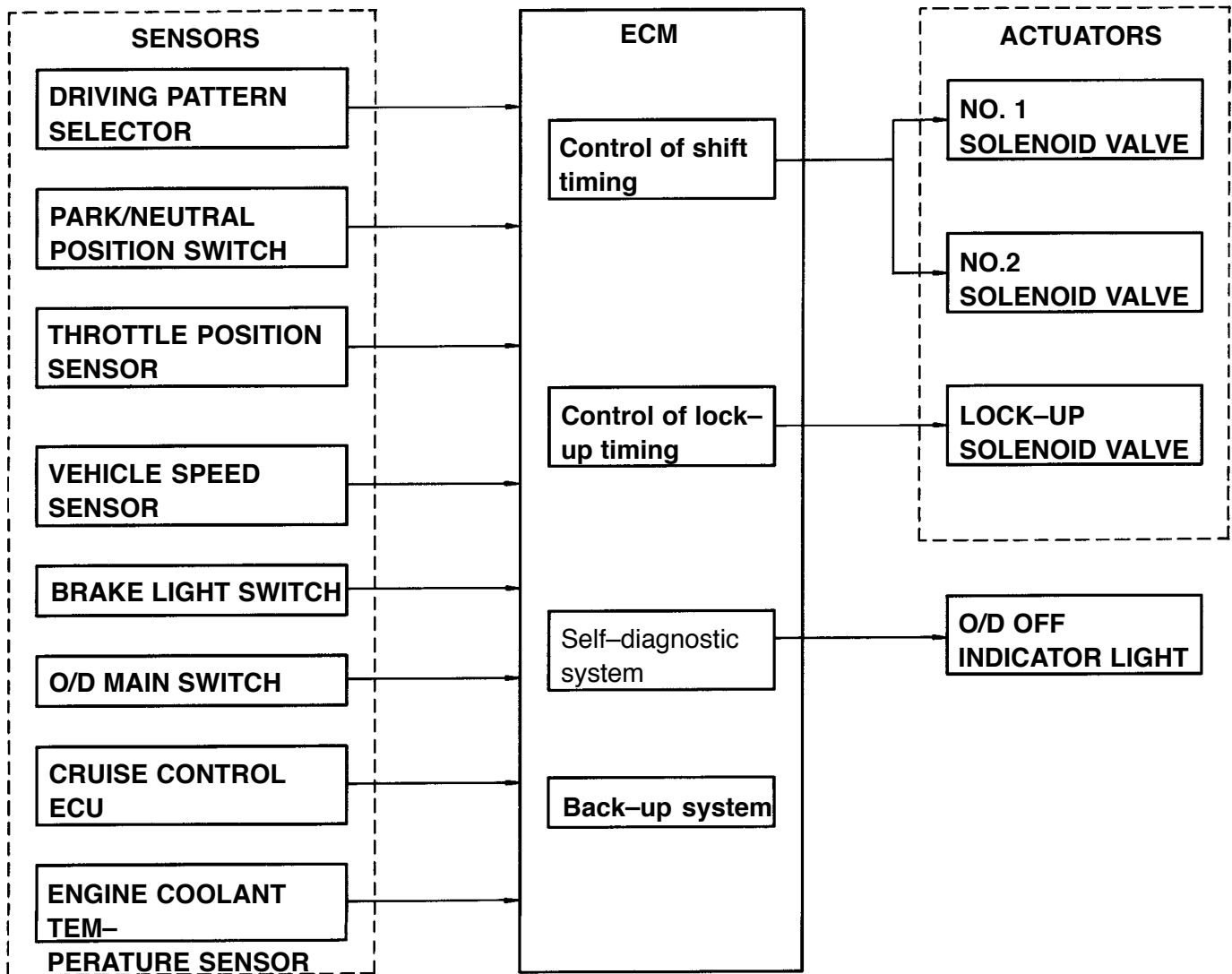



## FUNCTION OF ECM

### • Control of Shift Timing

The ECM has programmed into its memory the optimum shift pattern for each shift lever position (D, 2, L position) and driving mode (Normal or Power).

Based on the appropriate shift pattern, the ECM turns No. 1 and No.2 solenoid valves on or off in accordance with the vehicle speed signal from the vehicle speed sensor and the throttle opening signal from the throttle position sensor. In this manner, the ECM operates each shift valve, opening or closing the fluid passages to the clutches and brakes to permit up-shift or down-shift of the transmission.

HINT: The electronic control system provides shift timing and lock-up control only while the vehicle is traveling forward. In REVERSE, PARK, and NEUTRAL, the transmission is mechanically, not electronically controlled.

### • Control of Overdrive

Driving in overdrive is possible if the O/D main switch is on and the shift lever is in the D position. However, when the vehicle is being driven using the cruise control system (CCS), if the actual vehicle speed drops to about 4 km/h (2 mph) below the set speed while the vehicle is running in overdrive, the CCS ECU sends a signal to the ECM to release the overdrive and prevent the transmission from shifting back into overdrive until the actual vehicle speed reaches the speed set in the CCS memory.

On this model, if the engine coolant temperature falls below 70°C (158°F), preventing the transmission from up-shifting into overdrive.

### • Control of Lock-Up System

The ECM has programmed in its memory a lock-up clutch operation pattern for each driving mode (Normal or Power). Based on this lock-up pattern, the ECM turns lock-up solenoid valve on or off in accordance with the vehicle speed signals received from the vehicle speed sensor and the throttle opening signals from the throttle position sensor.

Depending on whether lock-up solenoid valve is on or off, the lock-up relay valve performs changeover of

the fluid passages for the converter pressure acting on the torque converter clutch to engage or disengage the lock-up clutch.

(Mandatory Cancellation of Lock-Up System)

If any of the following conditions exist, the ECM turns off lock-up solenoid valve to disengage the lock-up clutch.

- 1) The brake light switch comes on (during braking).
- 2) The IDL points of the throttle position sensor close (throttle valve fully closed).
- 3) The vehicle speed drops 4 km/h (2 mph) or more below the set speed while the cruise control system is operating.
- 4) The engine coolant temperature falls below 70°C (158°F).

The purpose of 1) and 2) above is to prevent the engine from stalling if the rear wheels lock up. The purpose of 3) is to cause the torque converter clutch to operate to obtain torque multiplication. The purpose of 4) is both to improve general driveability, and to speed up transmission warm-up.

Also, while the lock-up system is in operation, the ECM will temporarily turn it off during up-shift or down-shift in order to decrease shifting shock.

# TROUBLESHOOTING

## Basic Troubleshooting

Before troubleshooting an electronic controlled transmission, first determine whether the problem is electrical or mechanical. To do this, just refer to the basic troubleshooting flow-chart provided below.

If the cause is already known, using the basic troubleshooting chart below along with the general troubleshooting chart on the following pages should speed the procedure.

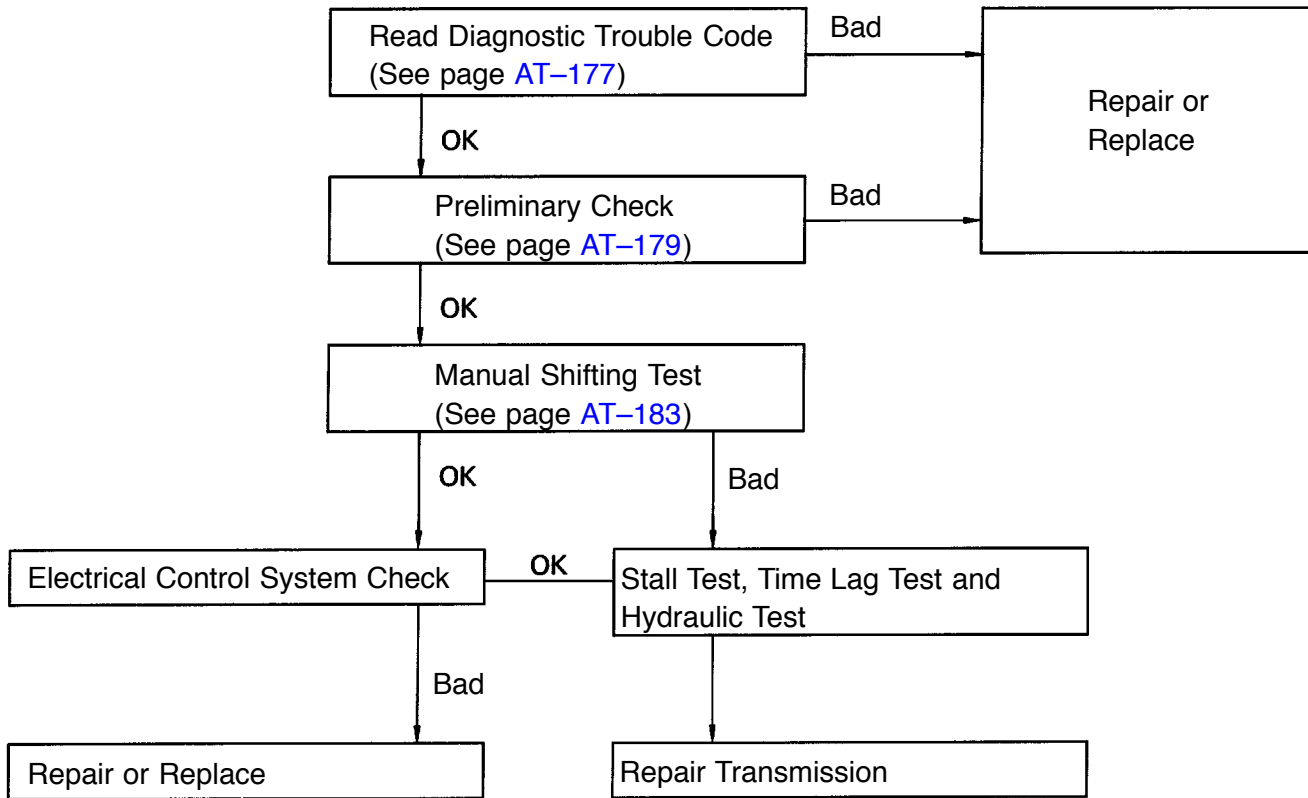

## General Troubleshooting

Problem	Possible cause	Remedy	Page
Fluid discolored or smells burnt	Fluid contaminated Torque converter clutch faulty  Transmission faulty	Replace fluid  Replace torque converter clutch Disassemble and inspect transmission	AT-181 AT-212  ★
Vehicle does not move in any forward position or reverse	Manual linkage out of adjustment Valve body or primary regulator faulty Parking lock pawl faulty Torque converter clutch faulty  Converter drive plate broken Oil pump intake screen blocked Transmission faulty	Adjust linkage Inspect valve body Inspect parking lock pawl Replace torque converter clutch Replace drive plate Clean screen Disassemble and inspect transmission	AT-182  AT-208 AT-212  AT-212 ★ ★
Shift lever position incorrect	Manual linkage out of adjustment Manual valve and lever faulty Transmission faulty	Adjust linkage Inspect valve body Disassemble and inspect transmission	AT-182 ★
Harsh engagement into any drive position	Throttle cable out of adjustment Valve body or primary regulator faulty Accumulator pistons faulty Transmission faulty	Adjust throttle cable Inspect valve body Inspect accumulator pistons Disassemble and inspect transmission	AT-182 ★ ★ ★
Delayed 1-2, 2-3 or 3-0/D up-shift, or down-shifts from O/D-3 or 3-2 and shifts back to O/D or 3	Electronic control faulty Valve body faulty Solenoid valve faulty	Inspect electronic control Inspect valve body Inspect solenoid valve	AT-184 AT-193
Slips on 1-2, 2-3 or 3-0/D up-shift, or slips or shudders on acceleration	Manual linkage out of adjustment Throttle cable out of adjustment Valve body faulty Solenoid valve faulty Transmission faulty	Adjust linkage Adjust throttle cable Inspect valve body Inspect solenoid valve Disassemble and inspect transmission	AT-182 AT-182 ★ AT-193 ★
Drag, binding or tie-up on 1-2, 2-3 or 3-0/D up-shift	Manual linkage out of adjustment Valve body faulty Transmission faulty	Adjust linkage Inspect valve body Disassemble and inspect transmission	AT-182 ★ ★

Remark ★: Refer to A340F Automatic Transmission Repair Manual. (Pub. No. RM271U)

## General Troubleshooting (Cont'd)

Problem	Possible cause	Remedy	Page
No lock-up in 2nd, 3rd or O/D	Electronic control faulty Valve body faulty Solenoid valve faulty Transmission faulty	Inspect electronic control Inspect valve body Inspect solenoid valve Disassemble and inspect transmission	AT-184 ★ AT-193 ★
Harsh down-shift	Throttle cable out of adjustment Throttle cable and cam faulty Accumulator pistons faulty Valve body faulty Transmission faulty	Adjust throttle cable Inspect throttle cable and cam Inspect accumulator pistons Inspect valve body Disassemble and inspect transmission	AT-182 AT-182 ★ ★ ★
No down-shift when coasting	Valve body faulty Solenoid valve faulty Electronic control faulty	Inspect valve body Inspect solenoid valve Inspect electronic control	★ AT-193 AT-184
Down-shift occurs too quickly or too late while coasting	Throttle cable faulty Valve body faulty Transmission faulty  Solenoid valve faulty Electronic control faulty	Inspect throttle cable Inspect valve body Disassemble and inspect transmission Inspect solenoid valve Inspect electronic control	AT-182 ★ ★  AT-193 AT-184
No O/D-3, 3-2 or 2-1 kick-down	Solenoid valve faulty Electronic control faulty Valve body faulty	Inspect solenoid valve Inspect electronic control Inspect valve body	AT-193 AT-184
No engine braking in 2 or L position	Solenoid valve faulty Electronic control faulty Valve body faulty Transmission faulty	Inspect solenoid valve Inspect electronic control Inspect valve body Disassemble and inspect transmission	AT-193 AT-184 ★ ★
Vehicle does not hold in P	Manual linkage out of adjustment Parking lock pawl cam and spring faulty	Adjust linkage Inspect cam and spring	AT-188 AT-208
No H2-H4, H4-L4, L4-H4 or H4-H2 change gear position of transfer	Transfer linkage out of adjustment Transfer faulty	Adjust linkage Disassemble and inspect transfer	AT-182 ★

Remark ★: Refer to A340F Automatic Transmission Repair Manual. (Pub. No. RM271 U)

## Diagnosis System

### DESCRIPTION

1. A self-diagnosis function is built into the electrical control system. Warning is indicated by the overdrive OFF indicator light.

HINT: Warning and diagnostic trouble codes can be read only when the overdrive switch is ON. If OFF, the overdrive OFF light is lit continuously and will not blink.

(a) If a malfunction occurs within the vehicle speed sensors (No. 1 or 2) or solenoids (No. 1, 2), the overdrive OFF light will blink to warn the driver.

However, there will be no warning of a malfunction with lock-up solenoid.

(b) The diagnostic trouble code can be read by the number of blinks of the overdrive OFF indicator light when terminals TE, and EI are connected.

(See page AT-178)

(c) The throttle position sensor or brake signal are not indicated, but inspection can be made by checking the voltage at terminal TT of the data link connector 1.

(d) The signals to each gear can be checked by measuring the voltage at terminal TT while driving.

2. The diagnostic trouble code is retained in memory by the ECM and due to back-up voltage, is not canceled out when the engine is turned off. Consequently, after repair, it is necessary to turn the ignition switch off and remove the MF I fuse

(15A) or disconnect the ECM connector to cancel out the diagnostic trouble code. (See page AT-178)

### HINT:

Low battery positive voltage will cause faulty operation of the diagnosis system. Therefore, always check the battery first.

Use a voltmeter and ohmmeter that have an impedance of at least 10 k $\Omega$ /V.

### CHECK "O/D OFF" INDICATOR LIGHT

1. Turn the ignition switch ON.
2. The "O/D OFF" light will come on when the O/D switch is placed at OFF.
3. When the O/D switch is set to ON, the "O/D OFF" light should go out.

If the "O/D OFF" light flashes when the O/D switch is set to ON, the electronic control system is faulty.

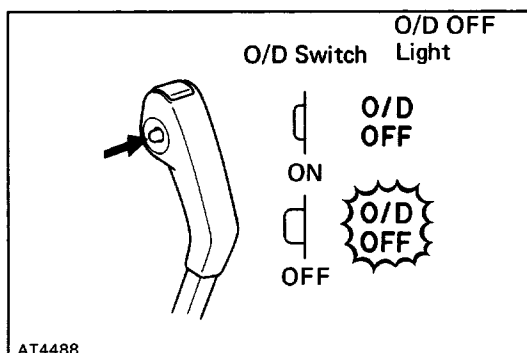
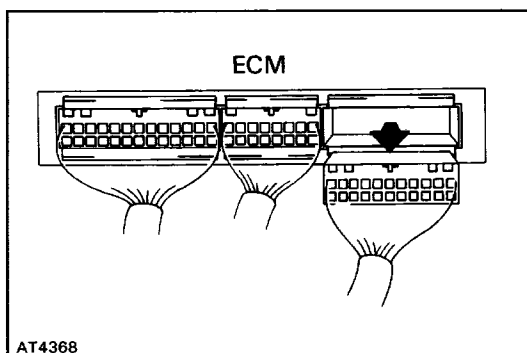
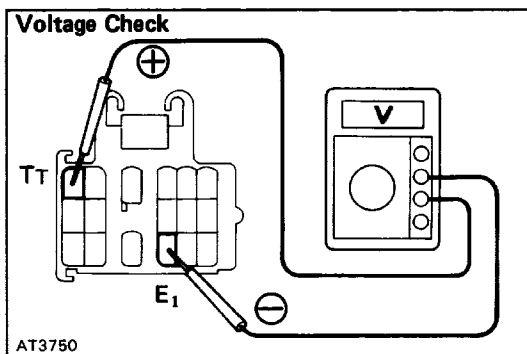
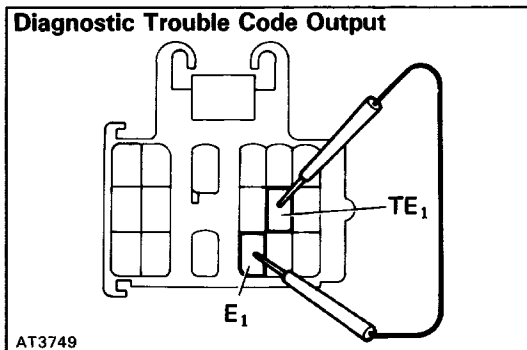
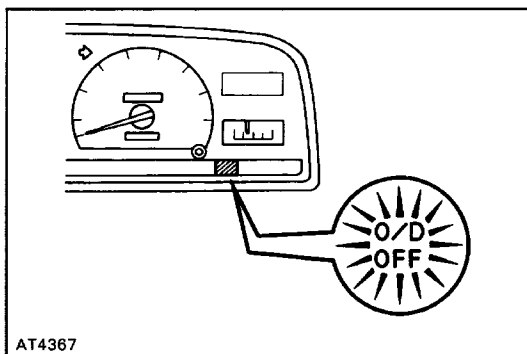

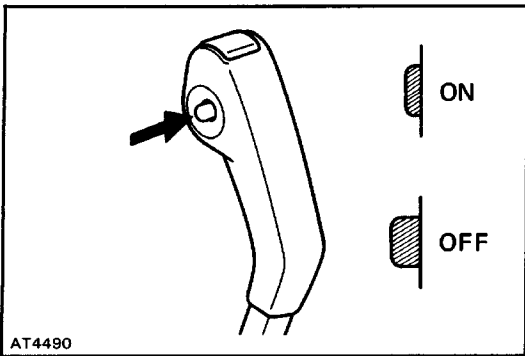

## READ DIAGNOSTIC TROUBLE CODE

### 1. TURN IGNITION SWITCH AND O/D SWITCH TO ON

Do not start the engine.

HINT: Warning and diagnostic trouble codes can be read only when the overdrive switch is ON. If OFF, the overdrive OFF light will light continuously and will not blink.

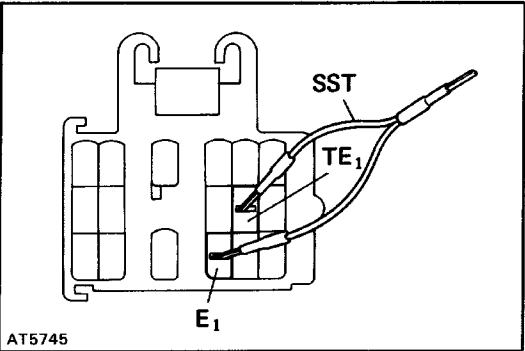

### 2. CONNECT TE, AND E, TERMINALS OF DATA LINK CONNECTOR 1

Using SST, connect terminals TE, and E1.  
SST 09843-18020

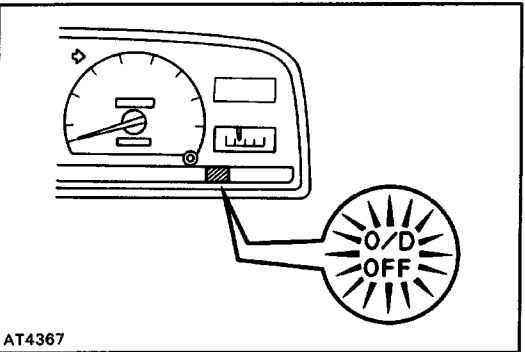

### 3. READ DIAGNOSTIC TROUBLE CODE

Read the diagnostic trouble code as indicated by the number of times the O/D OFF light flashes.

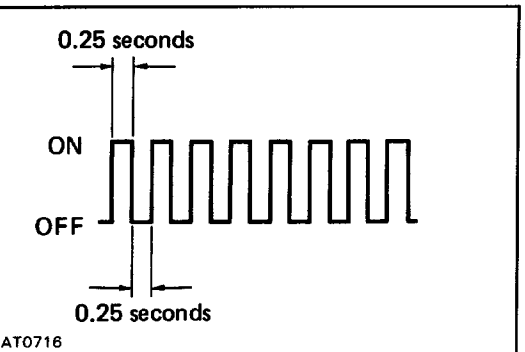

#### (Diagnostic Trouble Code Indication)

- If the system is operating normally, the light will flash 2 times per second.

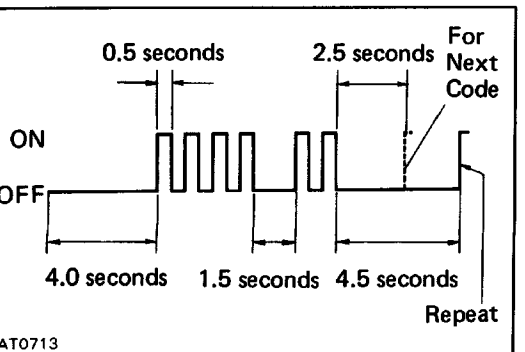







- In the event of a malfunction, the light will flash 1 time per second. The number of blinks will equal the first number and, after 1.5 seconds pause, the second number of the two digit diagnostic trouble code. If there are two or more codes, there will be a 2.5 seconds pause between each.

HINT: In the event of several trouble codes occurring simultaneously, indication will begin from the smaller value and continue to the larger.

### 4. REMOVE SST

## DIAGNOSTIC TROUBLE CODES

Code No.	Light Pattern	Diagnosis System
—		Normal
42		Defective No. 1 vehicle speed sensor (in combination meter)—severed wire harness or short circuit
61		Defective No.2 vehicle speed sensor (in ATM)—severed wire harness or short circuit
62		Severed No. 1 solenoid or short circuit—severed wire harness or short circuit
63		Severed No.2 solenoid or short circuit—severed wire harness or short circuit
64		Severed lock-up solenoid or short circuit—severed wire harness or short circuit

AT2020

HINT: If codes 62, 63 or 64 appear, there is an electrical malfunction in the solenoid.

Causes due to mechanical failure, such as a stuck valve, will not appear.

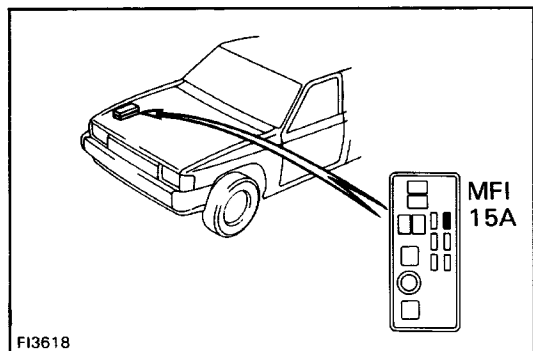

## CANCEL OUT DIAGNOSTIC TROUBLE CODE

- After repair of the trouble area, the diagnostic trouble code retained in memory by the ECM must be canceled by removing the MFI fuse (1 5A) for 10 seconds or more, depending on ambient temperature (the lower the temperature, the longer the fuse must be left out) with the ignition switch OFF.

HINT:

- Cancellation can be also done by removing the battery negative (-) terminal, but in this case other memory systems will be also canceled out.
  - The diagnostic trouble code can be also canceled out by disconnecting the ECM connector.
  - If the diagnostic trouble code is not canceled out, it will be retained by the ECM and appear along with a new code in event of future trouble.
- After cancellation, perform a road test to confirm that a "normal code" is now read on the O/D OFF light.

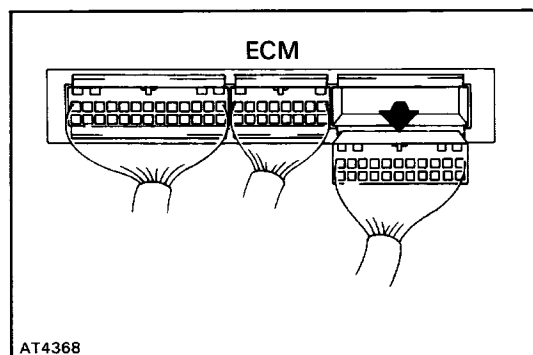

## TROUBLESHOOTING FLOW-CHART

### HINT:

- If diagnostic trouble code Nos. 42, 61, 62 or 63 are output, the overdrive OFF indicator light will begin to blink immediately to warn the driver. However, an impact or shock may cause the blinking to stop; but the code will still be retained in the ECM memory until canceled out.
- There is no warning for diagnostic trouble code No.64.
- In the event of a simultaneous malfunction of both No.1 and No.2 vehicle speed sensors, no diagnostic trouble code will appear and the fail-safe system will not function. However, when driving in the D position, the transmission will not up-shift from first gear, regardless of the vehicle speed.

### Diagnostic trouble code 42 (No.1 vehicle speed sensor circuitry)

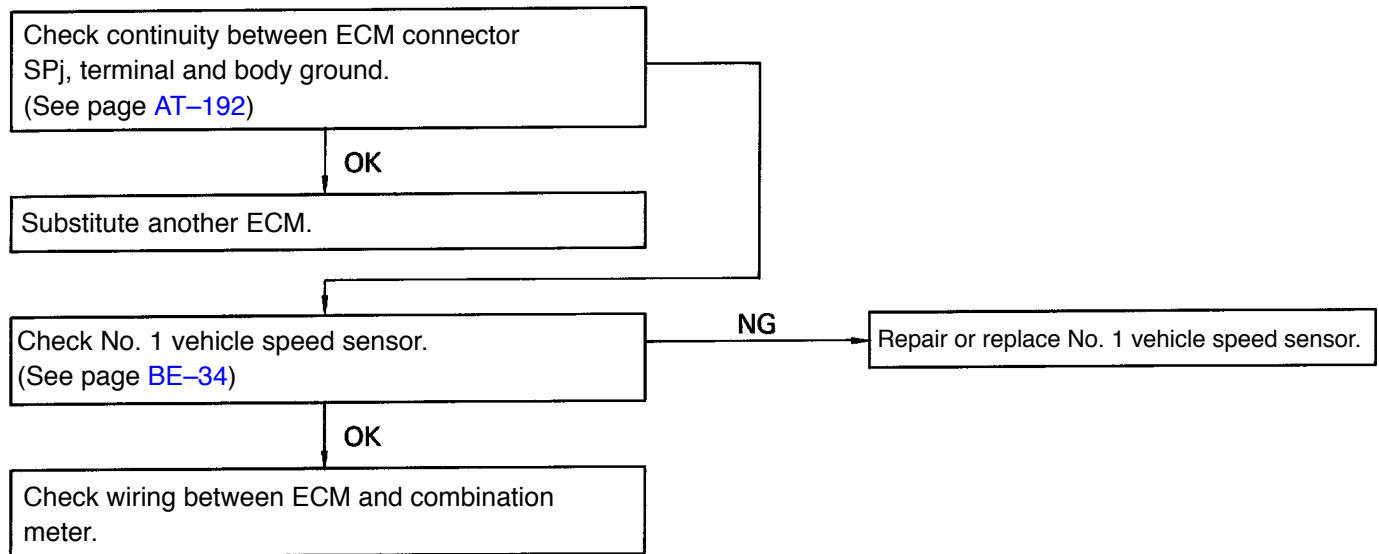

### Diagnostic trouble code 61 (No-2 vehicle speed sensor circuitry)

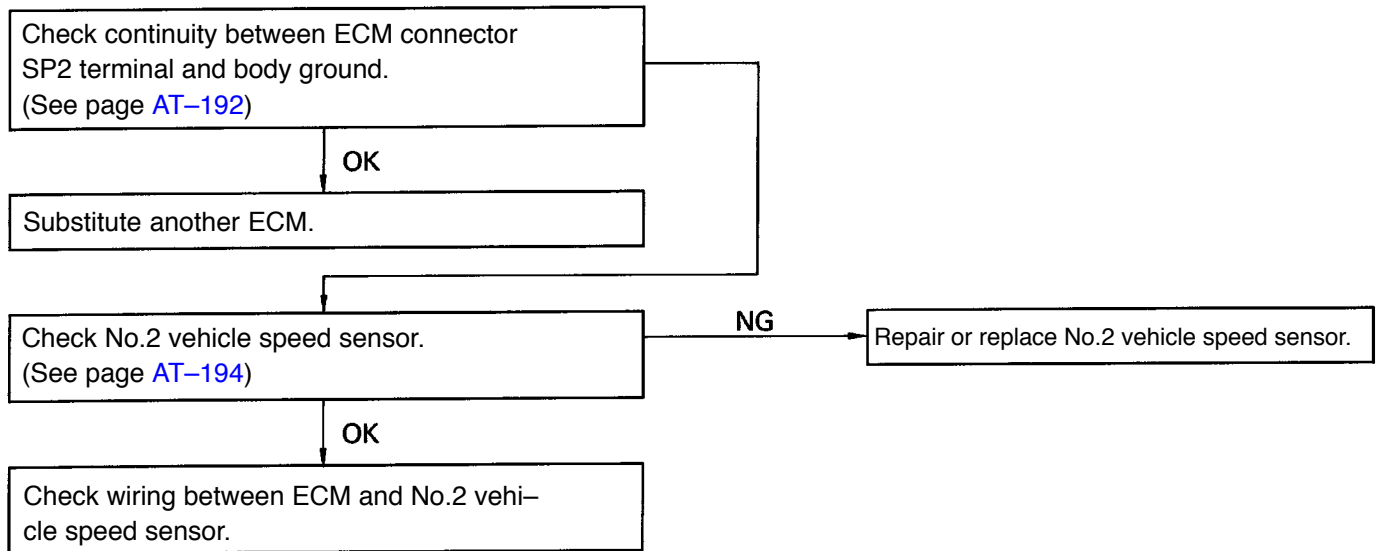



**Diagnostic trouble code 62 (No. 1 solenoid valve circuitry)**

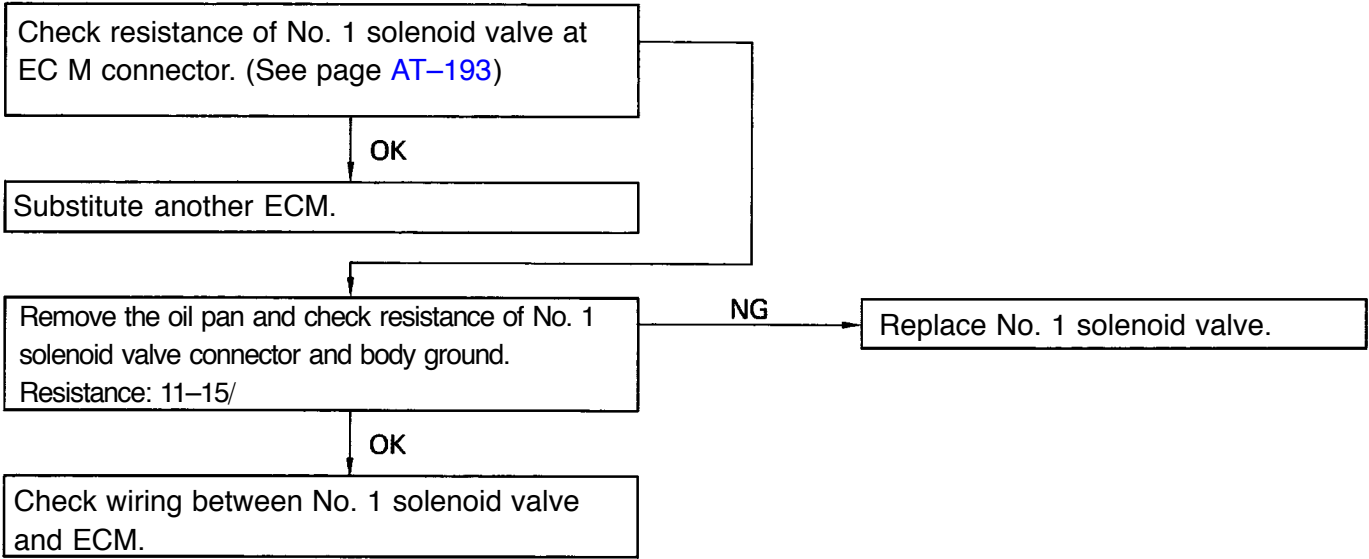

**Diagnostic trouble code 63 (No.2 solenoid valve circuitry)**

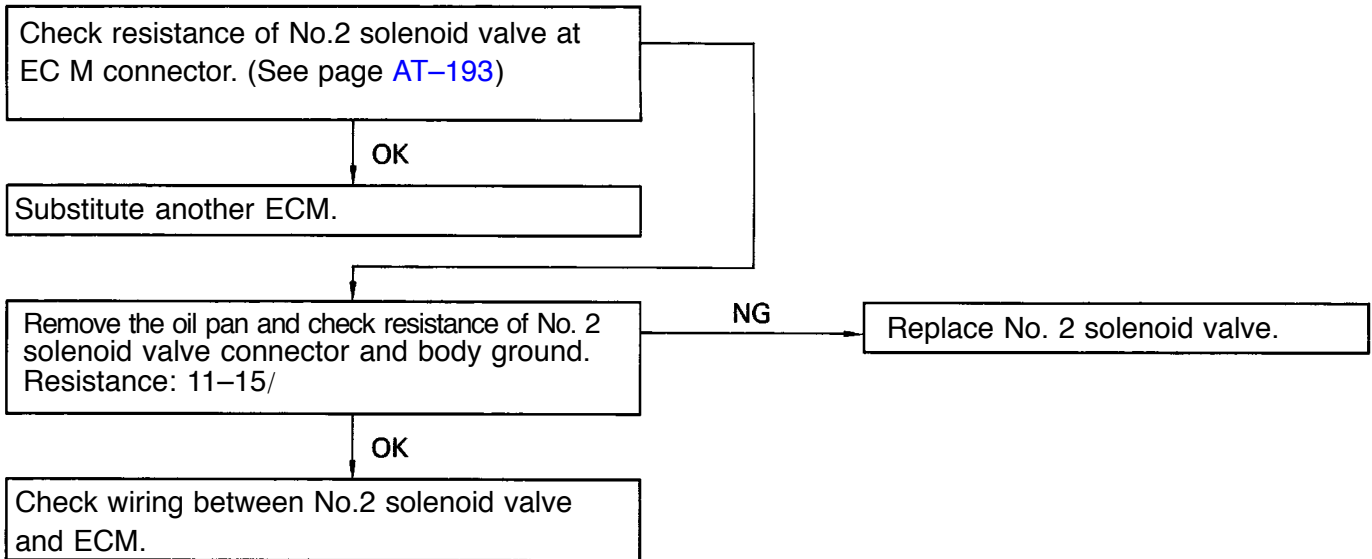

**Diagnostic trouble code 64 (Lock-up solenoid valve circuitry)**

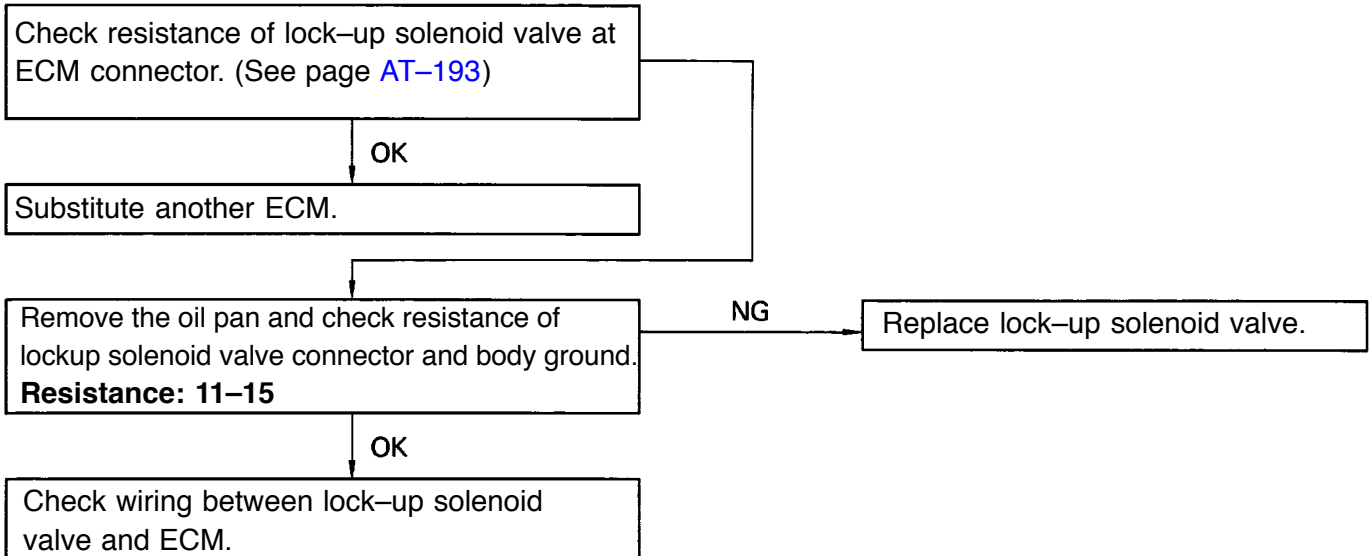

# Preliminary Check

## 1. CHECK FLUID LEVEL

HINT:

- The vehicle must have been driven so that the engine and transmission are at normal operating temperature. (Fluid temperature: 70–80°C or 158–176°F)
- Only use the COOL range on the dipstick as a rough reference when the fluid is replaced or the engine does not run.

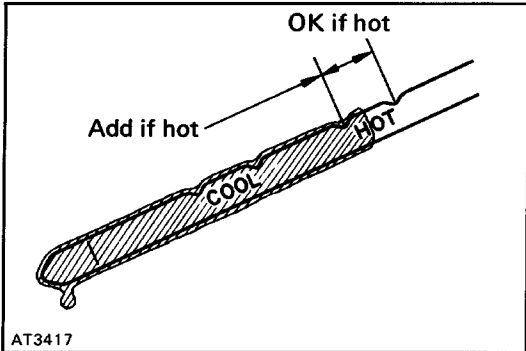

- Park the vehicle on a level surface, set the parking brake.
- With the engine idling, shift the shift lever into all positions from P to L position and return to P position.
- Pull out the transmission dipstick and wipe it clean.
- Push it back fully into the tube.
- Pull it out and check that the fluid level is in the HOT range.

If the level is at the low side, add fluid.

**Fluid type: ATF DEXRON®II**

**NOTICE: Do not overfill.**

## 2. CHECK FLUID CONDITION

If the fluid smells burnt or is black, replace it as following procedures.

- Remove the drain plug and drain the fluid.
- Reinstall the drain plug securely.
- With the engine OFF, add new fluid through the oil filler tube.

**Fluid type: ATF DEXRON® II**

**Capacity:**

**Total: 7.6 liters (8.0 US qts, 6.7 Imp. qts)**

**Drain and refill: 1.6 liters**

**(1.7 US qts, 1.4 Imp. qts)**

- Start the engine and shift the shift lever into all positions from P to L position and then shift into P position.
- With the engine idling, check the fluid level. Add fluid up to the COOL level on the dipstick.
- Check the fluid level with the normal operating temperature (70–80°C or 158–176°F) and add as necessary.

**NOTICE: Do not overfill.**

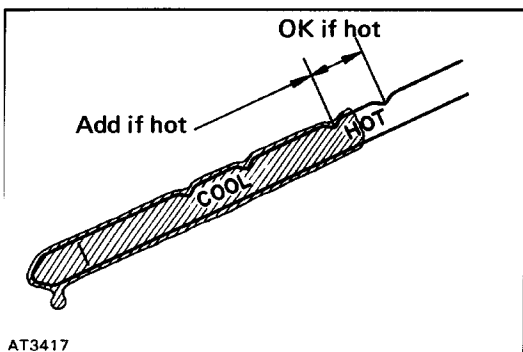
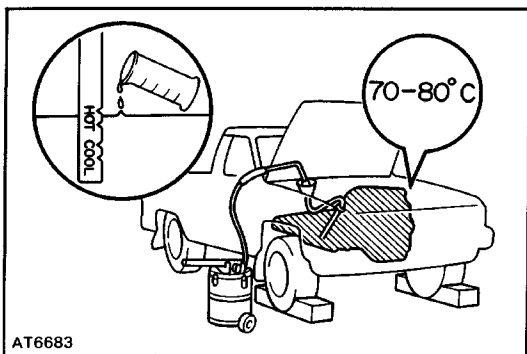
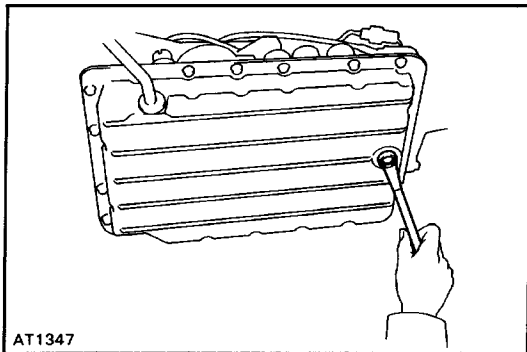

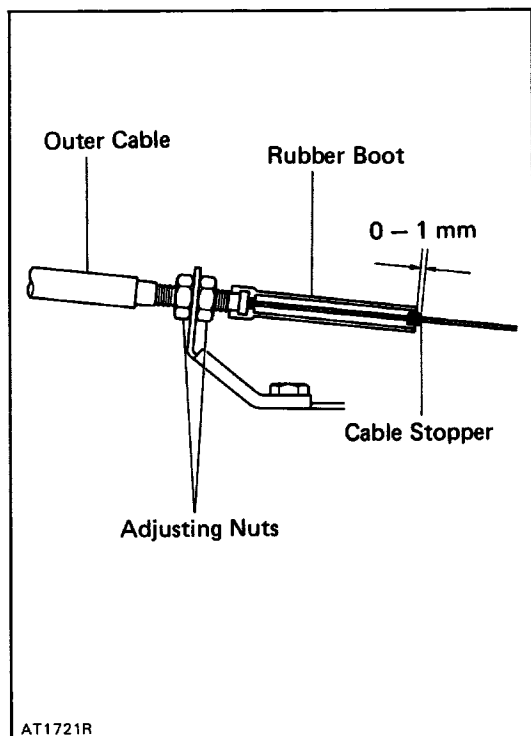

### 3. INSPECT THROTTLE CABLE

- (a) Depress the accelerator pedal all the way and check that the throttle valve opens fully.

HINT: If the valve does not open fully, adjust the accelerator cable.

- (b) Fully depress the accelerator pedal.
- (c) Measure the distance between the end of the boot and stopper on the cable.

**Standard distance: 0–1 mm (0–0.04 in.)**

If the distance is not standard, adjust the cable by the adjusting nuts.

### 4. INSPECT TRANSMISSION SHIFT LEVER POSITION

When shifting the shift lever from the N position to other position, check that the lever can be shifted smoothly and accurately indicates the position.

If the indicator is not aligned with the correct position, carry out the following adjustment procedures.

- (a) Loosen the nut on the shift lever.
- (b) Push the control shaft lever fully rearward.
- (c) Return the control shaft lever two notches to N position.
- (d) Set the shift lever to N position.
- (e) While holding the shift lever lightly toward the R position side, tighten the shift lever nut.
- (f) Start the engine and make sure that the vehicle moves forward when shifting the lever from the N to D position and reverse when shifting it to the R position.

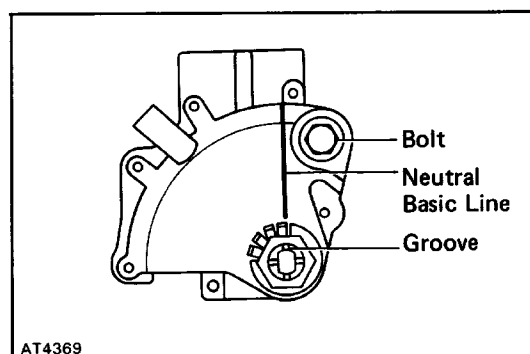
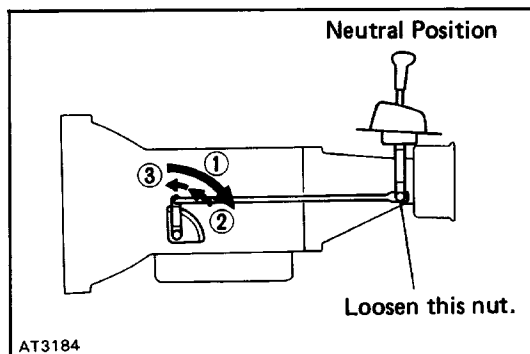

### 5. INSPECT PARK/NEUTRAL POSITION SWITCH

Check that the engine can be started with the shift lever only in the N or P position, but not in other positions.

If not as started above, carry out the following adjustment procedures.

- (a) Loosen the park/neutral position switch bolt and set the shift lever to the N position.
- (b) Align the groove and neutral basic line.
- (c) Hold in position and tighten the bolt.

**Torque: 13 N–m (130 kgf–cm, 9 ft–lbf)**

### 6. INSPECT IDLE SPEED (N POSITION)

Connect a tachometer test probe, to the data link connector 1 terminal IG (–), inspect the idle speed.

**Idle speed: 850 RPM**

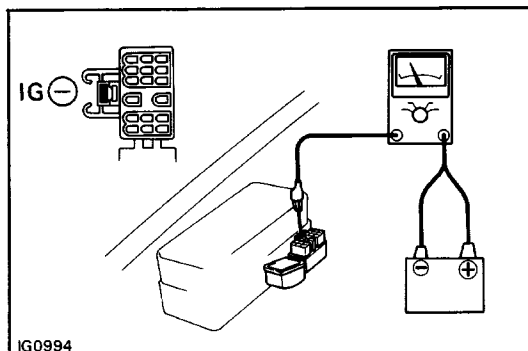

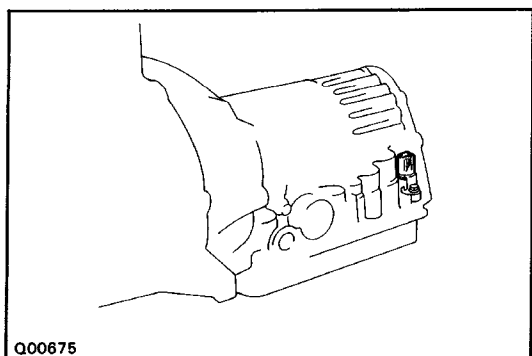

# Manual Shifting Test

HINT: With this test, it can be determined whether the trouble lies within the electrical circuit or is a mechanical problem in the transmission.

1. DISCONNECT SOLENOID WIRE
2. INSPECT MANUAL DRIVING OPERATION

Check that the shift and gear positions correspond with the table below.

Shift Position	D position	2 position	L position	R position	P position
Gear Position	O/D	3rd	1 st	Reverse	Pawl Lock

HINT: If the 1, 2 and D position gear positions are difficult to distinguish, perform the following road test.

- While driving, shift through the L, 2 and D positions. Check that the gear change corresponds to the shift position.

If any abnormality is found in the above test, the problem lies in transmission itself.

3. CONNECT SOLENOID WIRE
4. CANCEL OUT DIAGNOSTIC TROUBLE CODE (See page AT-178)

**REFERENCE: Possible gear positions in accordance with solenoid operating conditions.**

Position	NORMAL			NO. 1 SOLENOID MALFUNCTIONING			NO.2 SOLENOID MALFUNCTIONING			BOTH SOLENOIDS MALFUNCTIONING		
	Solenoid Valve		Gear Position	Solenoid Valve		Gear Position	Solenoid Valve		Gear Position	Solenoid Valve		Gear Position
	No. 1	No.2		No. 1	No. 2		No. 1	No. 2		No. 1	No. 2	
D position	ON	OFF	1st	x	ON (OFF)	3rd (O/D)	ON	x	1st	x	x	O/D
	ON	ON	2nd	x	ON	3rd	OFF (ON)	x	O/D (1 SO)	x	x	O/D
	OFF	ON	3rd	x	ON	3rd	OFF	x	O/D	x	x	O/D
	OFF	OFF	O/D	x	OFF	O/D	OFF	x	O/D	x	x	O/D
2 position	ON	OFF	1st	x	ON (OFF)	3rd (O/D)	ON	x	1st	x	x	3rd
	ON	ON	2nd	x	ON	3rd	OFF (ON)	x	3rd (1st)	x	x	3rd
	OFF	ON	3rd	x	ON	3rd	OFF	x	3rd	x	x	3rd
L position	ON	OFF	1st	x	OFF	1st	ON	x	1st	x	x	1st
	ON	ON	2nd	x	ON	2nd	ON	x	1st	x	x	1st

( ) : No fail-safe function      x : Malfunctions

# Electronic Control System

## PRECAUTION

Do not open the cover or the case of the ECM and various computer unless absolutely necessary. (If the IC terminals are touched, the IC may be destroyed by static electricity.)

## ELECTRONIC CONTROL CIRCUIT

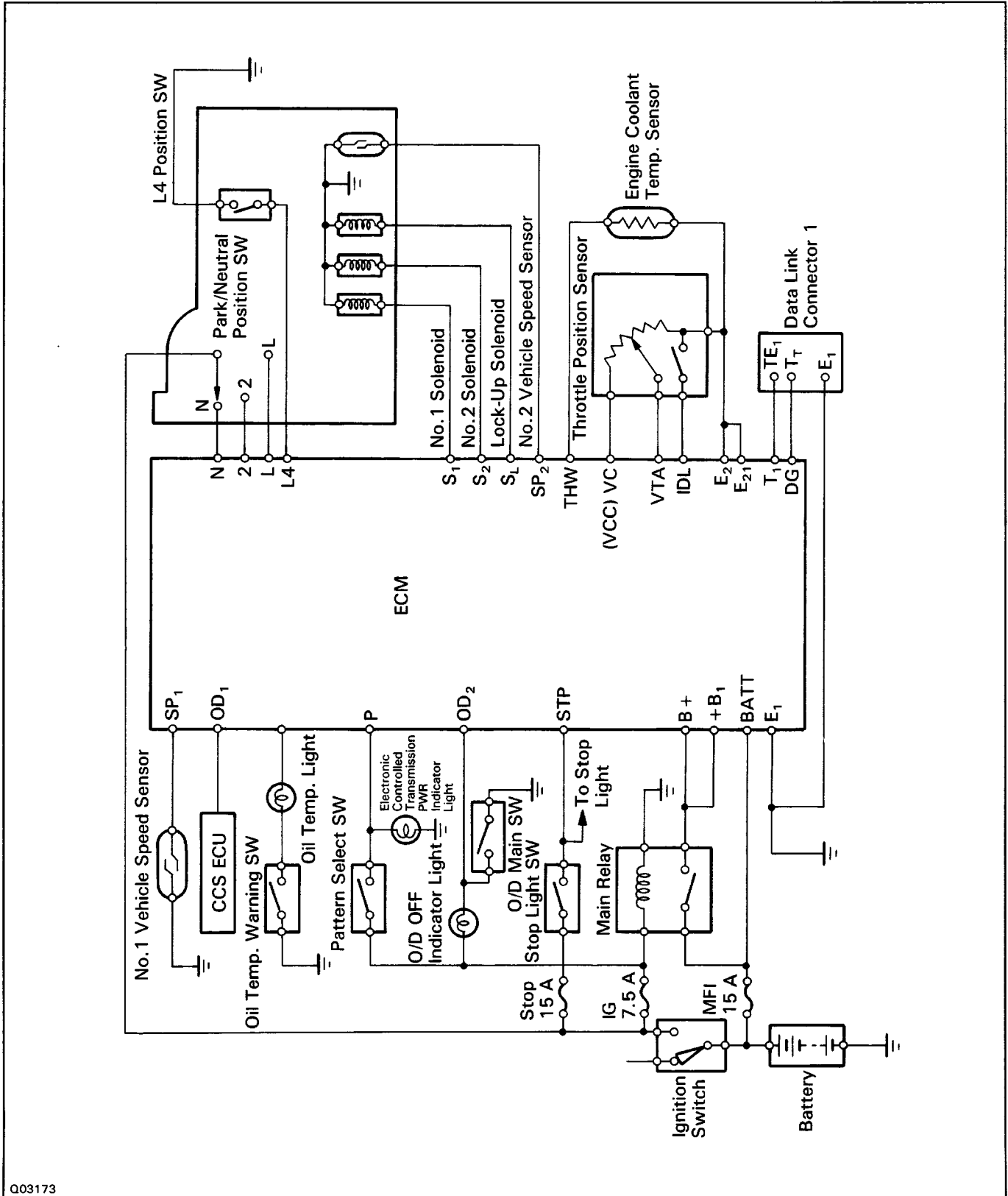

### ELECTRONIC CONTROL COMPONENTS

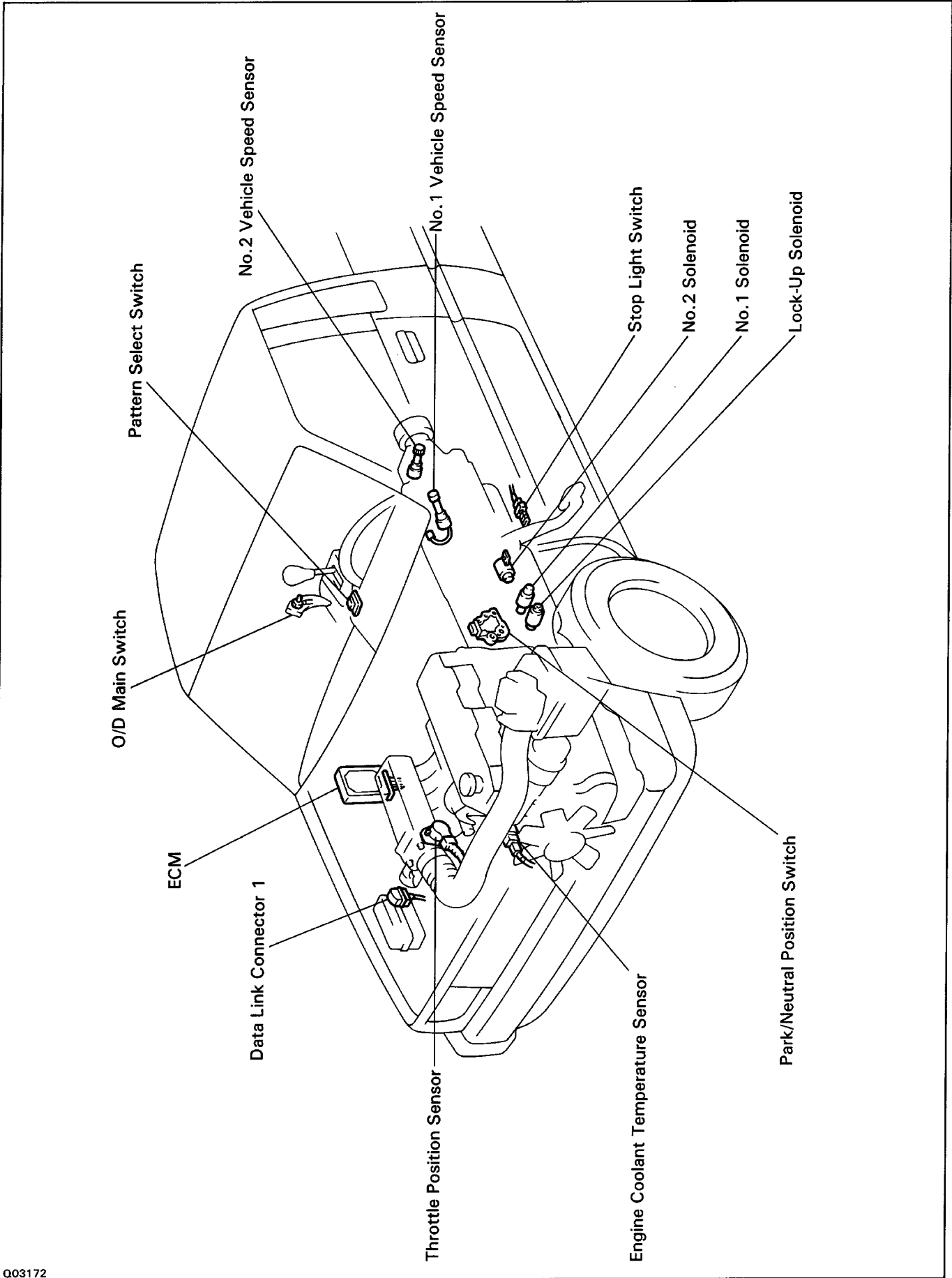

# TROUBLESHOOTING FLOW-CHART

## Trouble No. 1 No Shifting

Warm up engine  
 Engine coolant temp.: 80°C (176°F)  
 ATF temp.: 50–80°C (122–176°F)

Connect a voltmeter to data link connector 1 terminals T<sub>T</sub> and E1. Does T<sub>T</sub> terminal voltage vary with changes in throttle opening?

Yes

No

Is voltage between ECM terminals STP and E , as follows?  
 0 V: Brake pedal released  
 10–14 V: Brake pedal depressed

No

Brake signal faulty

Yes

- Throttle position signal faulty
- T<sub>T</sub> terminal wire open or short

Disconnect solenoid wire connector and road test. Does the transmission operate in the respective gear when in the following positions while driving?

- D position .... Overdrive
- 2 position .... 3rd gear
- L position .... 1 st gear

No

Transmission faulty

Yes

Continued on page [AT-187](#)

Continued from page AT-186

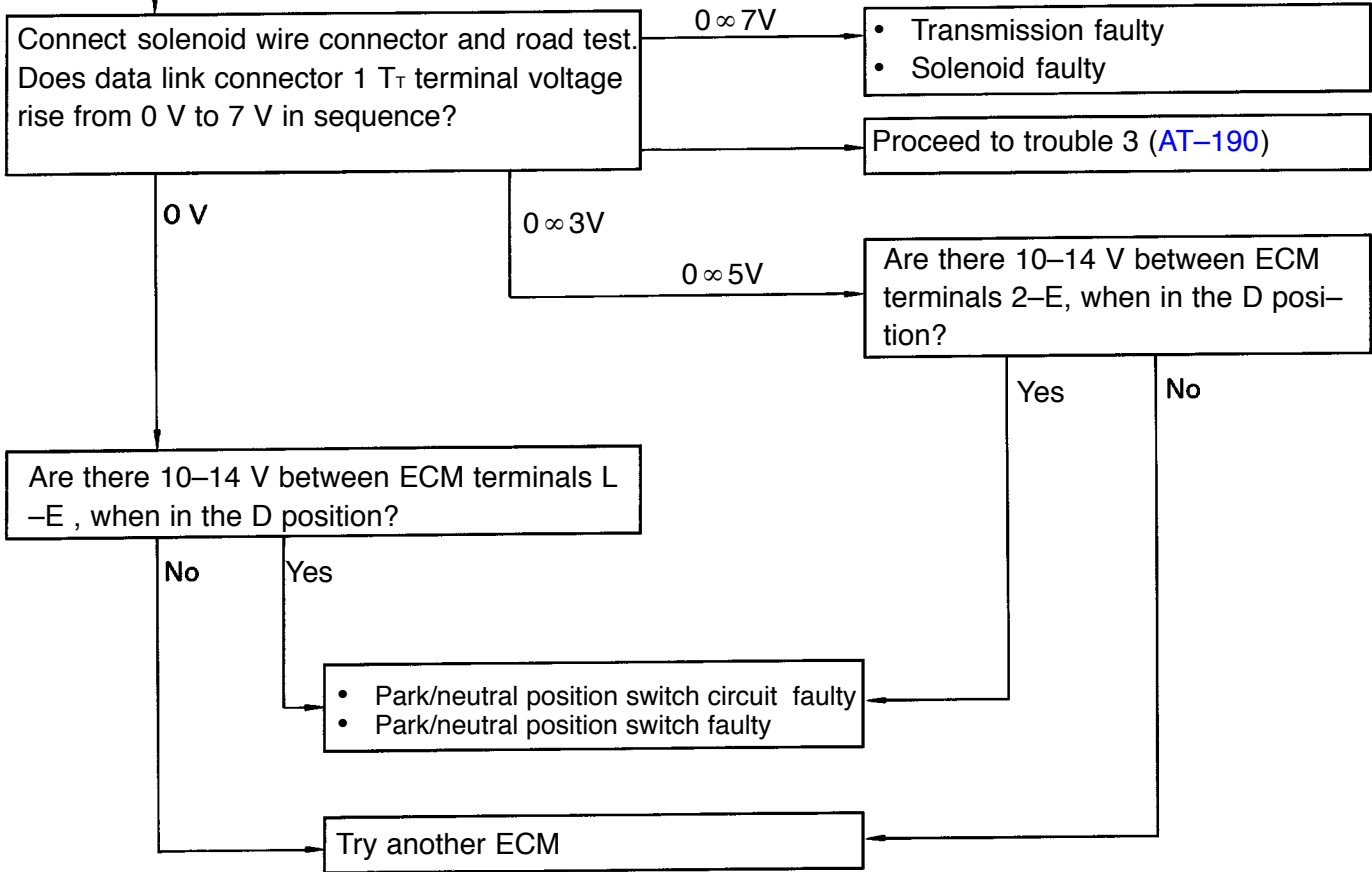



## Trouble No.2 Shift point too high or too low

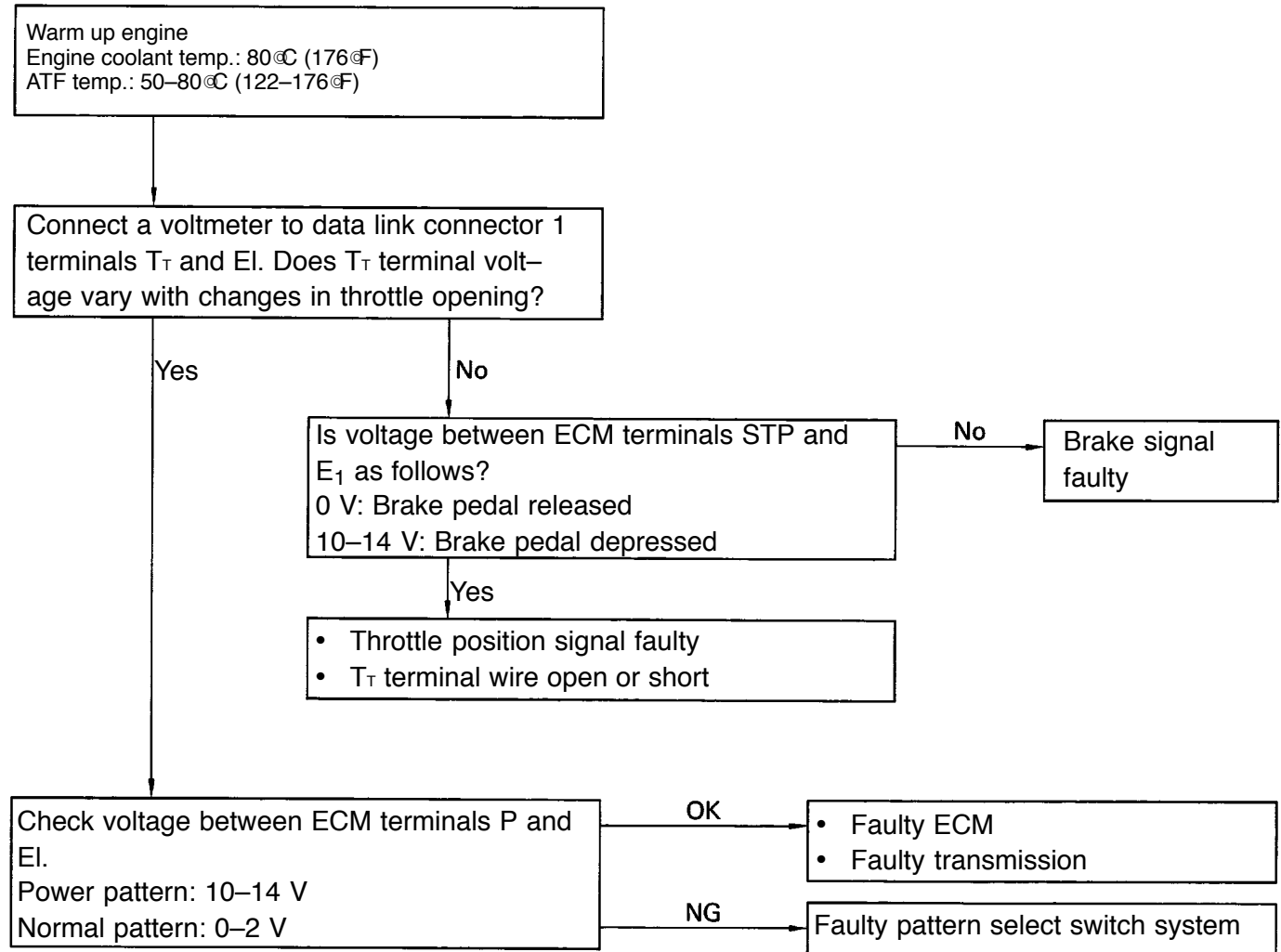

**Trouble No-3 No up-shift to overdrive (After warm-up)**

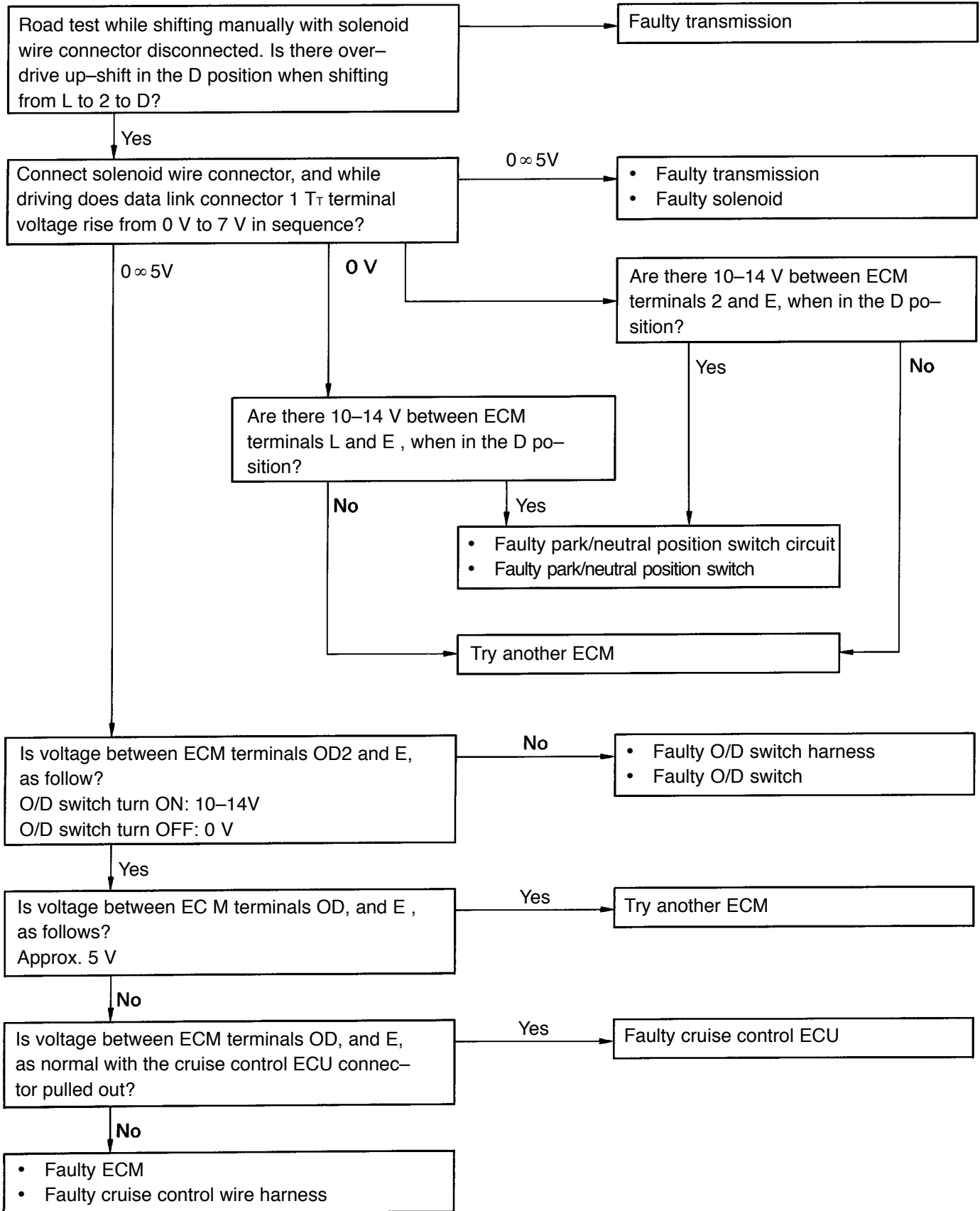

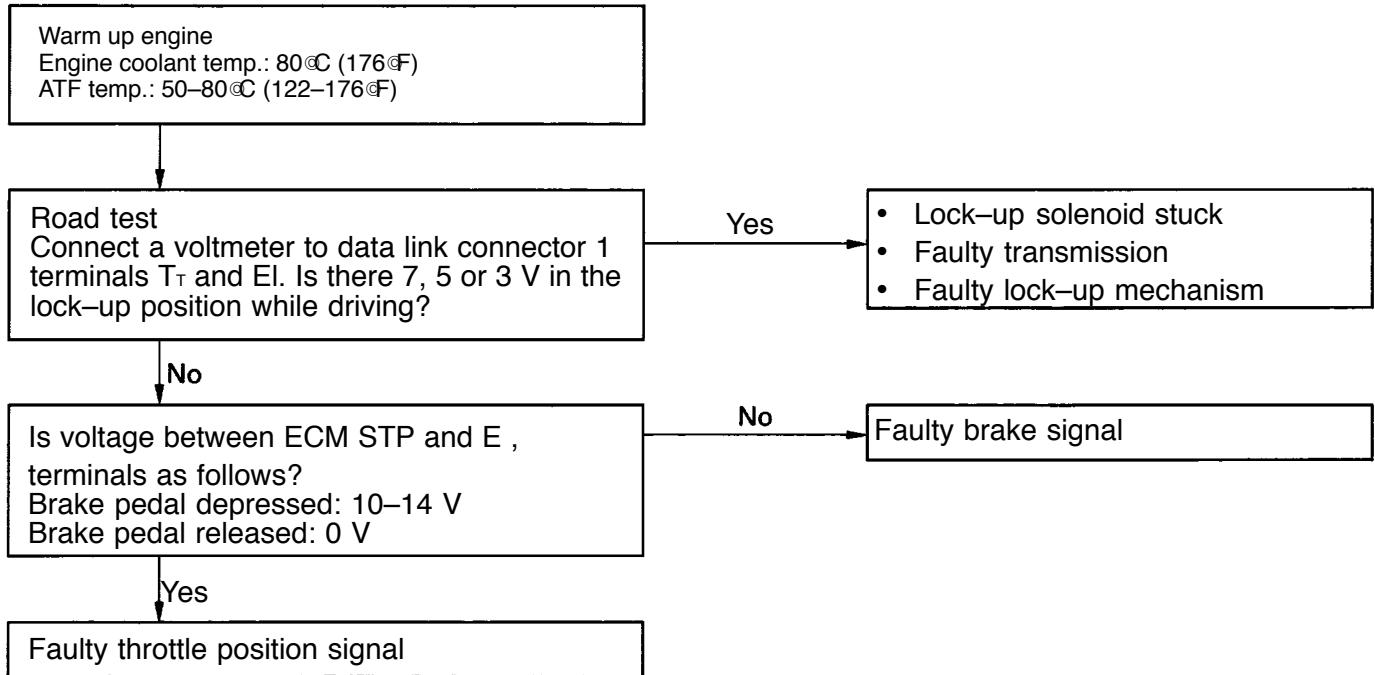
**Trouble No.4** No lock-up (After warm-up)

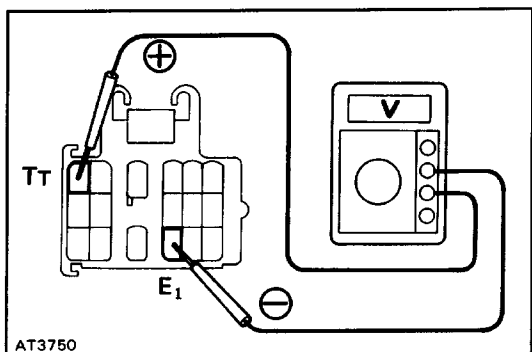

## INSPECTION OF T<sub>T</sub> TERMINAL VOLTAGE

### 1. INSPECT THROTTLE POSITION SENSOR SIGNAL

- (a) Turn the ignition switch to ON. Do not start the engine.
- (b) Connect a voltmeter to data link connector 1 terminals T<sub>T</sub> and E<sub>1</sub>.

(c) While slowly depressing the accelerator pedal, check that T<sub>T</sub> terminal voltage rises in sequence. If the voltage does not change in proportion to the throttle opening angle, there is a malfunction in the throttle position sensor or circuit.

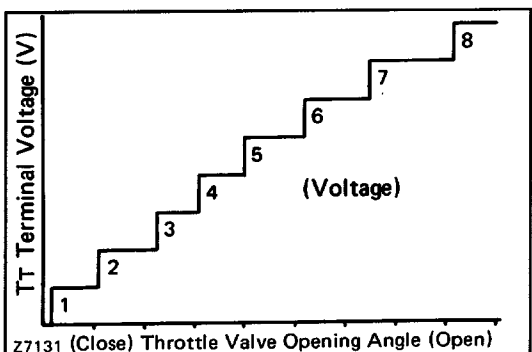

### 2. INSPECT BRAKE SIGNAL

- (a) Depress the accelerator pedal until the T<sub>T</sub> terminal indicates 8 V.
- (b) Depress the brake pedal and check the voltage reading from the T<sub>T</sub> terminal.

Brake pedal depressed ..... 0 V  
 Brake pedal released ..... 8 V

If not as indicated, there is a malfunction in either the stop light switch or circuit.

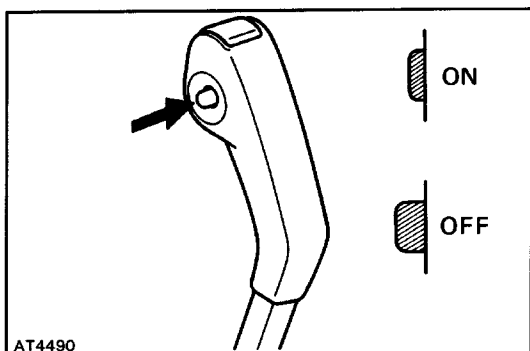

### 3. INSPECT EACH UP-SHIFT POSITION

- (a) Warm up the engine.  
**Engine coolant temperature: 80 °C (176 °F)**
- (b) Turn the O/D switch to "ON".
- (e) Place the pattern select switch in "Normal" and the shift lever into the D position.
- (d) During a road test (above 10 km/h or 6 mph) check that voltage at the T<sub>T</sub> terminal is as indicated below for each up-shift position.

If the voltage rises from 0 V to 7 v in the sequence shown, the control system is okay.

The chart on the left shows the voltmeter reading and corresponding gears.

T <sub>T</sub> Terminal (V)	Gear Position
0	1st
2	2nd
3	2nd Lock-up
4	3rd
5	3rd Lock-up
6	O/D
7	O/D Lock-up

HINT: Determine the gear position by a light shock or change in engine RPM when shifting. The lock-up clutch will turn ON only infrequently during normal 2nd and 3rd gear operation. To trigger this action, press the accelerator pedal to 50% or more of its stroke. At less than 50%, the voltage may change in the sequence 2 V-4 V-6 V-7V.

# INSPECTION OF ELECTRONIC CONTROL COMPONENTS

## 1. INSPECT VOLTAGE OF ECM CONNECTOR

- (a) Remove the cowl side trim of passenger side.
- (b) Turn on the ignition switch.
- (c) Measure the voltage at each terminal.

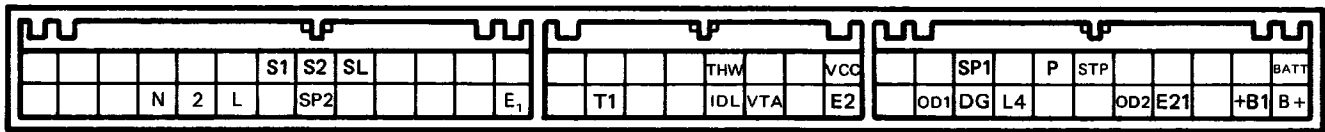
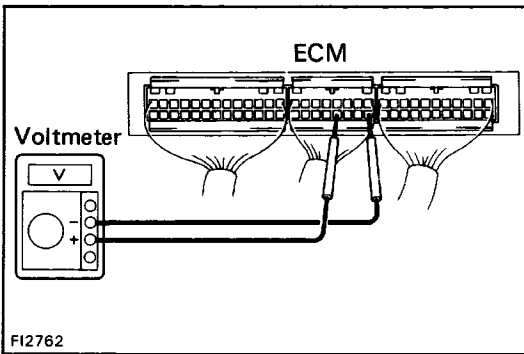

FI2796

Terminal	Measuring condition	Voltage (V)	
S <sub>1</sub> - E <sub>1</sub>	—	10 - 14	
S <sub>2</sub> , S <sub>L</sub> - E <sub>1</sub>	—	0	
P - E <sub>1</sub>	PWR pattern	10 - 14	
	NORM pattern	0 - 2	
STP - E <sub>1</sub>	Brake pedal is depressed	10 - 14	
	Brake pedal is released	0	
THW - E <sub>2</sub> (E <sub>21</sub> )	Engine coolant temp. 80°C (1 760F)	0.1 - 1.0	
IDL - E <sub>2</sub> (E <sub>21</sub> )	Throttle valve fully closed	0	
	Throttle valve open	10 - 14	
VTA - E <sub>2</sub> (E <sub>21</sub> )	Throttle valve fully closed	0.1 - 1.0	
	Throttle valve fully open	3 - 5	
VC (VCC) - E <sub>2</sub> (E <sub>21</sub> )	—	4 - 6	
OD <sub>1</sub> - E <sub>1</sub>	—	5	
OD <sub>2</sub> - E <sub>1</sub>	O/D main switch turned ON	10 - 14	
	O/D main switch turned OFF	0	
SP <sub>1</sub> - E <sub>1</sub>	Cruise control main switch OFF	Standing still	0 or 5
		Vehicle moving	2 - 3
SP <sub>2</sub> - E <sub>1</sub>	Standing still	0 or 5	
	Vehicle moving	2 - 3	

Terminal	Measuring condition	Voltage (V)
N - E <sub>1</sub>	N position	10 - 14
	Except N position	0 - 2
2 - E <sub>1</sub>	2 position	10 - 14
	Except 2 position	0 - 2
L - E <sub>1</sub>	L position	10 - 14
	Except L position	0 - 2
L <sub>4</sub> - E <sub>1</sub>	Transfer shift position H2 or H4	10 - 14
	Transfer shift position L4	0
B + (+B <sub>1</sub> ) - E <sub>1</sub>	-	10 - 14
BATT - E <sub>1</sub>	-	10 - 14

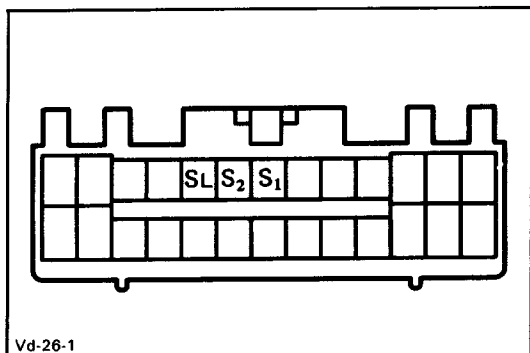

## 2. INSPECT SOLENOID

- Disconnect the connector from the ECM.
- Measure the resistance between S<sub>1</sub>, S<sub>2</sub>, SL and ground.  
Resistance: 11-15/
- Apply battery voltage to each terminal. Check that an operation noise can be heard from the solenoid.

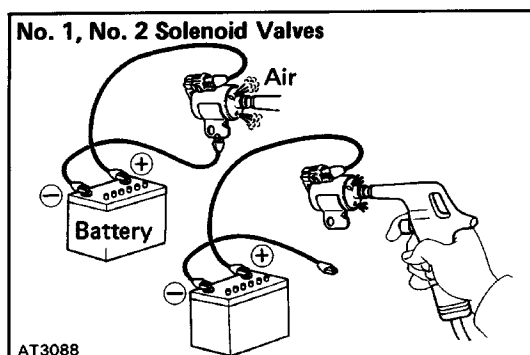

## 3. CHECK SOLENOID SEALS

If there is foreign material in the solenoid valve, there will be no fluid control even with solenoid operation.

- Check No. 1, No. 2 solenoid valves.  
Check that the solenoid valves do not leak when low-pressure compressed air is applied.  
When supply battery positive voltage to the solenoids, check that the solenoid valves open.

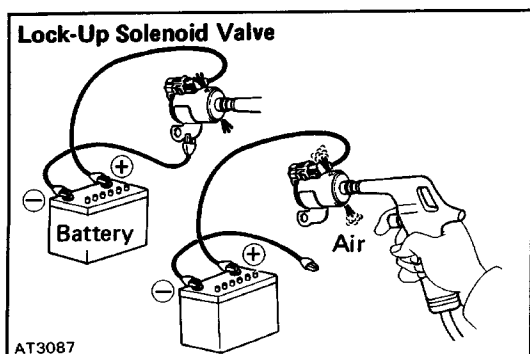

- Check the lock-up solenoid valve.  
Applying 490 kPa (5 kgf/cm<sup>2</sup>, 71 psi) of compressed air, check that the solenoid valve opens.  
When supply battery positive voltage to the solenoid, check that the solenoid valve does not leak the air.

If a malfunction is found during voltage inspection (step 1.), inspect the components listed below.

**4. INSPECT PARK/NEUTRAL POSITION SWITCH**

(See page AT-203)

**5. INSPECT THROTTLE POSITION SENSOR**

Using an ohmmeter, check the resistance between each terminal.

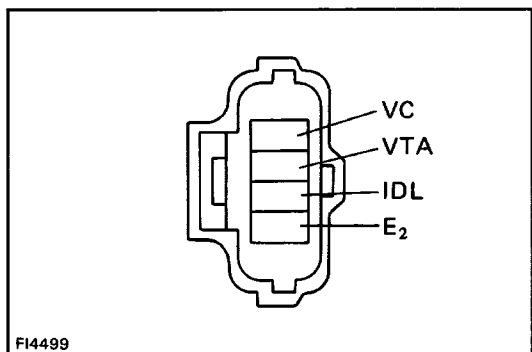

FI4499

Terminal	Throttle valve condition	Resistance (kΩ)
IDL-E2	Fully closed	Less than 2.3
	Open	Infinity
VC-E2	-	3.9 - 9.0
VTA-E2	Fully closed	0.47 - 6.1
	Fully open	3.1 - 12.1

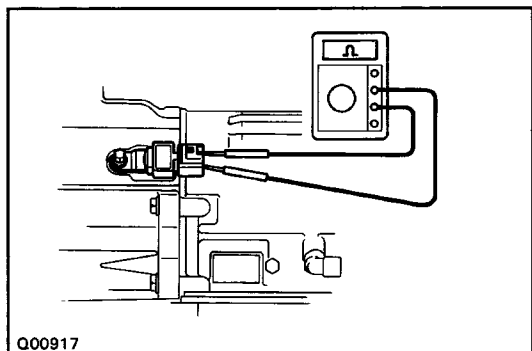

Q00917

**6. INSPECT NO.2 VEHICLE SPEED SENSOR**

- (a) Jack up the rear wheel on one side.
- (b) Connect an ohmmeter between the terminals.
- (e) Spin the wheel and check that the meter needle deflects from 0/ to ∞/.

**7. INSPECT NO. 1 VEHICLE SPEED SENSOR**

(See step 6. on page AT-194)

**8. INSPECT PATTERN SELECT SWITCH**

Using an ohmmeter, check the continuity of the terminals for each switch position.

HINT: As there are diodes inside, be careful of the tester probe polarity.

Terminal	4	6
Pattern		
PWR	○	○
NORM		

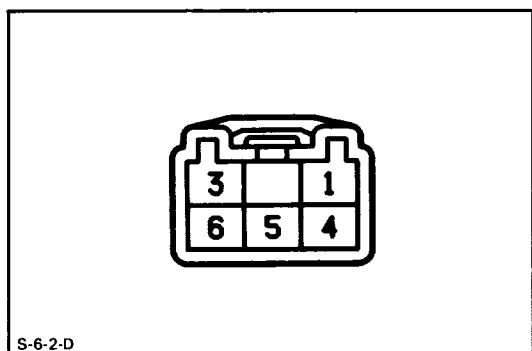

S-6-2-D

**9. INSPECT O/D SWITCH**

Using an ohmmeter, check the continuity of the terminals for each switch position.

Terminal	1	3
SW position		
ON		
OFF	○	○

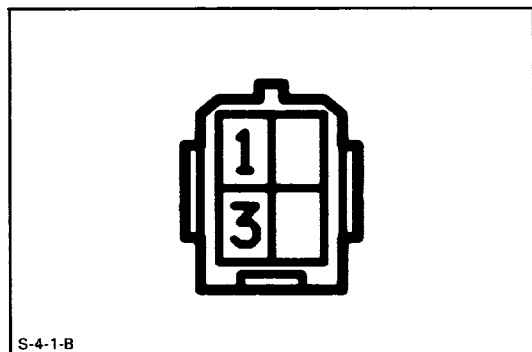

S-4-1-B

**10. INSPECT ENGINE COOLANT TEMPERATURE SENSOR**

(See page FI-115)

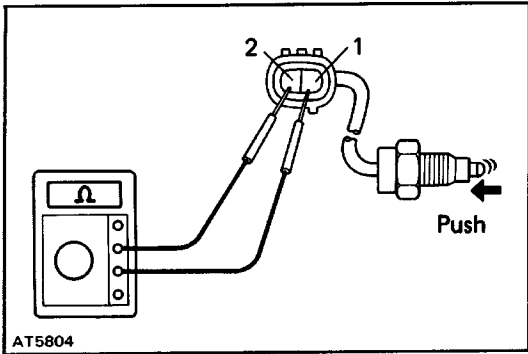

**11. INSPECT TRANSFER POSITION SWITCH**

Check that there is continuity between each terminal as shown.

Switch Position	Specified
Push	Continuity
Free	No continuity

If operation is not as specified, replace the switch.

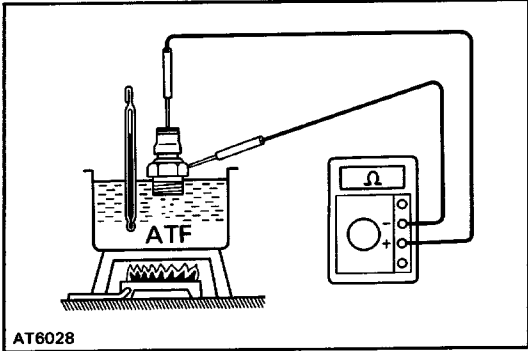

**12. INSPECT TRANSMISSION FLUID TEMPERATURE SWITCH**

Check that there is continuity at the temperature of 145°C–155°C (325°F–343°F).

If continuity is not as specified, replace the switch.



# Mechanical System Tests

## STALL TEST

The object of this test is to check the overall performance of the transmission and engine by measuring the stall speeds in the D and R positions.

### NOTICE:

- Perform the test at normal operating fluid temperature (50–80°C or 122–176°F).
- Do not continuously run this test longer than 5 seconds.
- To ensure safety, conduct this test in a wide, clear, level area, which provides good traction.
- The stall test should always be carried out in pairs. One should observe the conditions of wheels or wheel stoppers outside the vehicle while the other is performing the test.

## MEASURE STALL SPEED

- (a) Check the front and rear wheels.
- (b) Connect a tachometer to the engine.
- (c) Fully apply the parking brake.
- (d) Keep your left foot pressed firmly on the brake pedal.
- (e) Start the engine.
- (f) Shift into the D position. Step all the way down on the accelerator pedal with your right foot. Quickly read the stall speed at this time.

**NOTICE: Release the accelerator pedal and stop test if the rear wheels begin to rotate before the engine speed reaches specified stall speed.**

**Stall speed: 2,200 ± 150 RPM**

- (g) Perform the same test in R position.

## EVALUATION

- (a) If the stall speed is the same for both positions but lower than specified value:
  - Engine output may be insufficient
  - Stator one-way clutch is not operating properly

HINT: If more than 600 RPM below the specified value, the torque converter clutch could be faulty.

- (b) If the stall speed in D position is higher than specified:
  - Line pressure too low
  - Forward clutch slipping
  - No.2 one-way clutch not operating properly
  - O/D one-way clutch not operating properly
- (c) If the stall speed in R position is higher than specified:
  - Line pressure too low
  - Direct clutch slipping
  - First and reverse brake slipping
  - O/D one-way clutch not operating properly
- (d) If the stall speed in both R and D positions are higher than specified:
  - Line pressure too low
  - Improper fluid level
  - O/D one-way clutch not operating properly

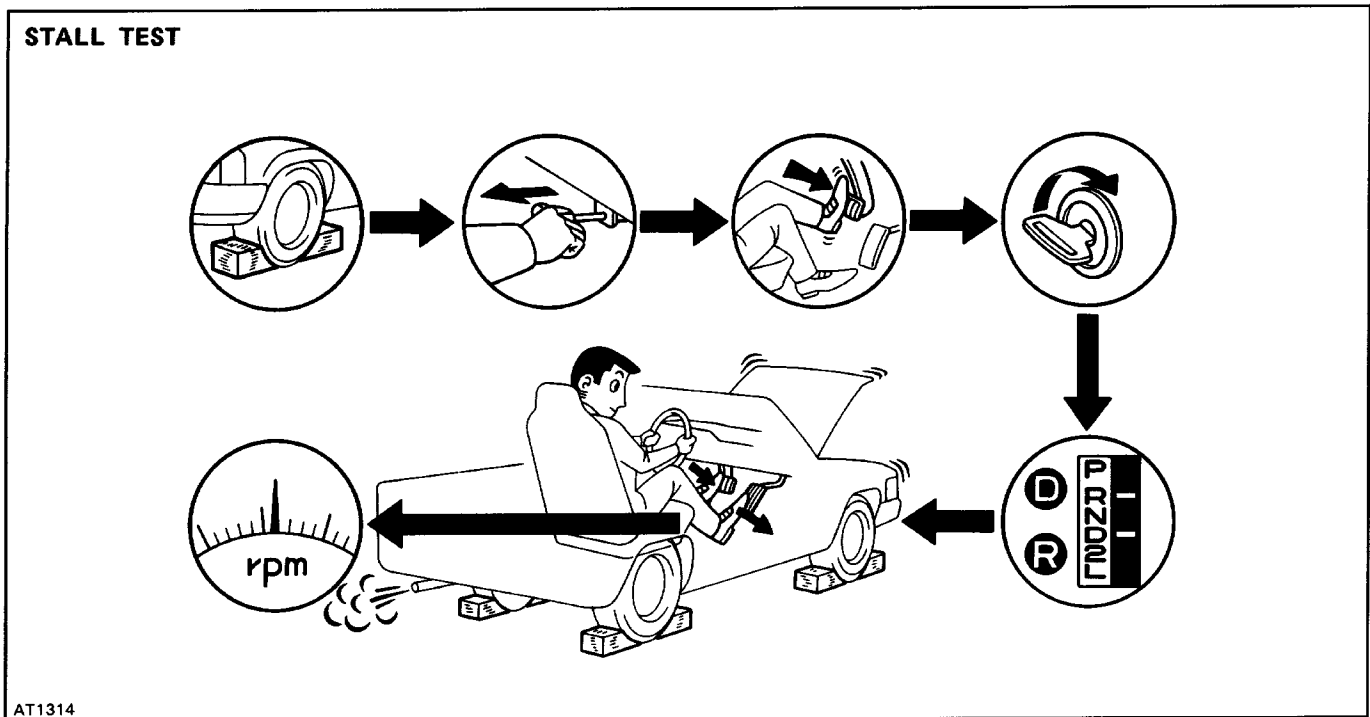

### TIME LAG TEST

When the shift lever is shifted while the engine is idling, there will be a certain time lapse or lag before the shock can be felt. This is used for checking the condition of the O/D direct clutch, forward clutch, direct clutch and first and reverse brake.

#### NOTICE:

- Perform the test at normal operating fluid temperature (50–80°C or 122–176°F).
- Be sure to allow one minute interval between tests.
- Make three measurements and take the average value.

### MEASURE TIME LAG

- Fully apply the parking brake.
- Start the engine and check the idle speed.  
Idle speed: 850 RPM  
(N position)
- Shift the shift lever from N to D position. Using a stop watch, measure the time it takes from shifting the lever until the shock is felt.  
Time lag: Less than 1.2 seconds
- In same manner, measure the time lag for N–R.  
Time lag: Less than 1.5 seconds

### EVALUATION

- If N–i D time lag is longer than specified:
  - Line pressure too low
  - Forward clutch worn
  - O/D one–way clutch not operating properly
- If N–R time lag is longer than specified:
  - Line pressure too low
  - Direct clutch worn
  - First and reverse brake worn
  - O/D one–way clutch not operating properly

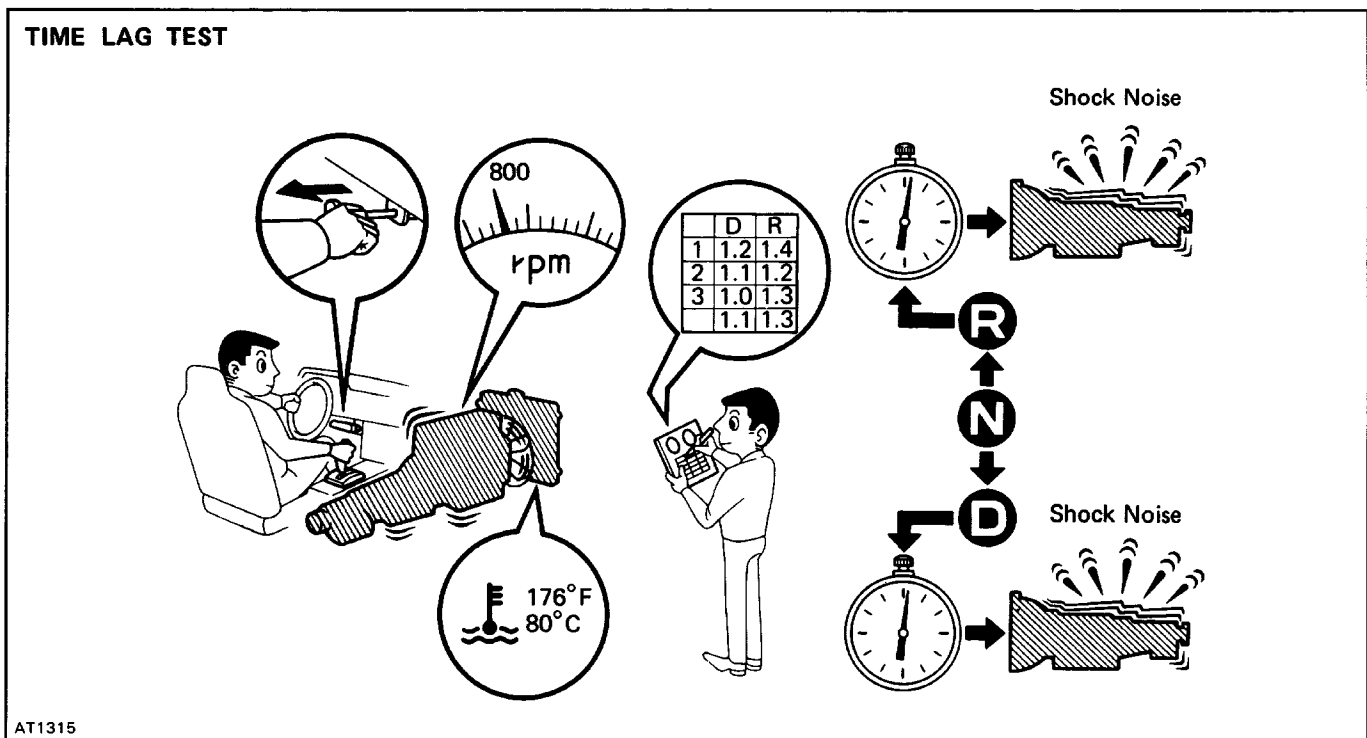

**HYDRAULIC TEST**

**PREPARATION**

- (a) Warm up the transmission fluid.
- (b) Remove the transmission case test plug and connect the hydraulic pressure gauge. SST 09992-00094 (Oil pressure gauge)

**NOTICE:**

- Perform the test at normal operating fluid temperature (50-80°C or 122-176°F).
- The line pressure test should always be carried out in pairs. One should observe the conditions of wheels or wheel stoppers outside the vehicle while the other is performing the test.

**MEASURE LINE PRESSURE**

- (a) Fully apply the parking brake and check the four wheels.
- (b) Start the engine and check idling RPM.
- (c) Keep your left foot pressed firmly on the brake pedal and shift into D position.
- (d) Measure the line pressure when the engine is idling.
- (e) Press the accelerator pedal all the way down. Quickly read the highest line pressure when engine speed reaches stall speed.

**NOTICE:** Release the accelerator pedal and stop test if the rear wheels begin to rotate before the en-

kPa (kgf/cm<sup>2</sup>, psi)

D position		R position	
Idling	Stall	Idling	Stall
363 - 422 (3.7 - 4.3, 53 - 61)	932 - 1,177 (9.5 - 12.0, 135 - 171)	490 - 588 (5.0 - 6.0, 71 - 85)	1,294 - 1,638 (13.2 - 16.7, 188 - 238)

If the measured pressures are not up to specified values, recheck the throttle cable adjustment and perform a retest.

**EVALUATION**

- (a) If the measured values at all positions are higher than specified:
  - Throttle cable out of adjustment
  - Throttle valve defective
  - Regulator valve defective
- (b) If the measured values at all positions are lower than specified:
  - Throttle cable out of adjustment
  - Throttle valve defective
  - Regulator valve defective
  - Oil pump defective
  - O/D direct clutch defective
- (c) If pressure is low in the D position only:
  - D position circuit fluid leakage
  - Forward clutch defective
- (d) If pressure is low in the R position only:
  - R position circuit fluid leakage
  - Direct clutch defective
  - First and reverse brake defective

**HYDRAULIC TEST**

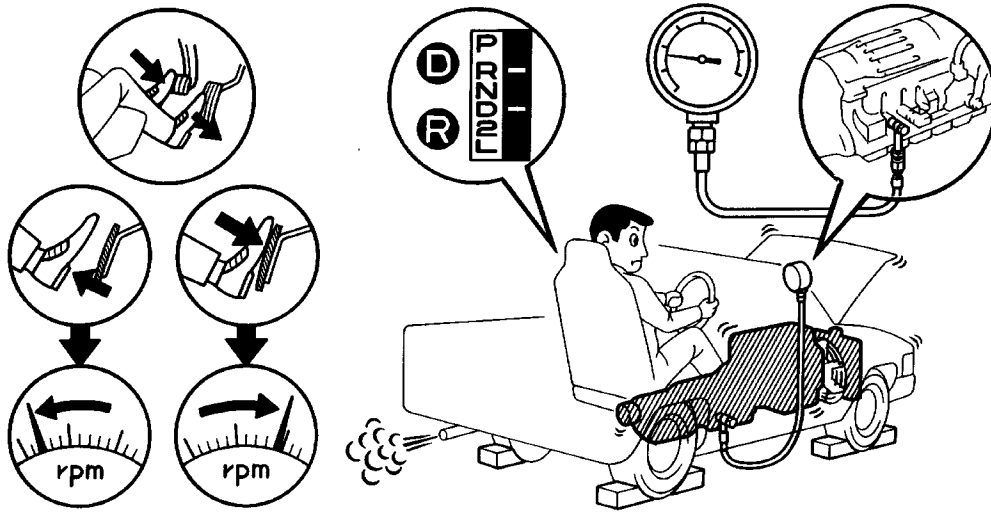

## ROAD TEST

**NOTICE: Perform the test at normal operating fluid temperature (50–80°C or 122–176°F).**

### 1. D POSITION TEST IN NORM AND PWR PATTERN POSITIONS

Shift into the D position and hold the accelerator pedal constant at the full throttle valve opening position.

- (a) 1–2, 2–3 and 3–O/D up–shifts should take place, and shift points should conform to those shown in the automatic shift schedule.

Conduct a test under both Normal and Power patterns.

**HINT:** There is no O/D up–shift or lock–up when the engine coolant temp. is below 70°C (158°F).

#### EVALUATION

- (1) If there is no 1 → 2 up–shift:  
No.2 solenoid is stuck  
1–2 shift valve is stuck
- (2) If there is no 2 → 3 up–shift:  
No.1 solenoid is stuck  
2–3 shift valve is stuck
- (3) If there is no 3 → O/D up–shift:  
3–4 shift valve is stuck
- (4) If the shift point is defective:  
Throttle valve, 1–2 shift valve, 2–3 shift valve, 3–4 shift valve etc., are defective
- (5) If the lock–up is defective:  
Lock–up solenoid is stuck  
Lock–up relay valve is stuck

- (b) In the same manner, check the shock and slip at the 1 → 2, 2 → 3, and 3 → O/D up–shifts.

#### EVALUATION

If the shock is excessive:

- Line pressure is too high
- Accumulator is defective
- Check ball is defective

- (c) Run at the D position lock–up or O/D gear and check for abnormal noise and vibration.

**HINT:** The check for the cause of abnormal noise and vibration must be made with extreme care as it could also be due to loss of balance in the propeller shaft, differential, torque converter clutch, etc.

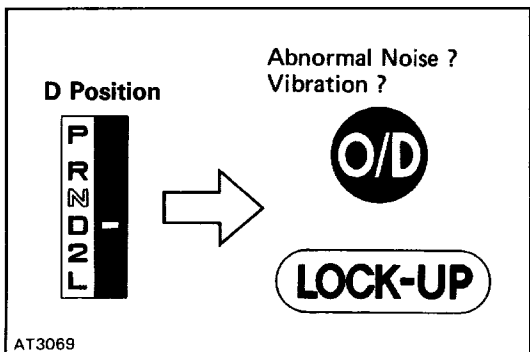
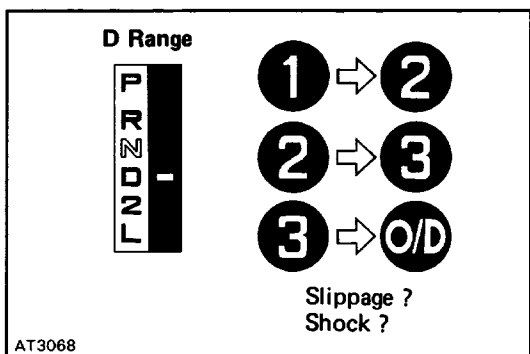
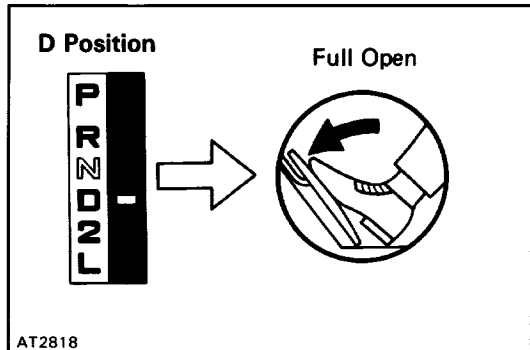

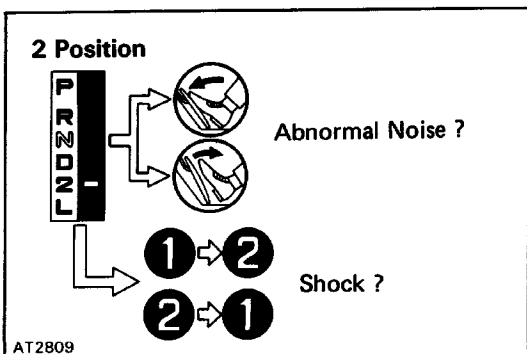
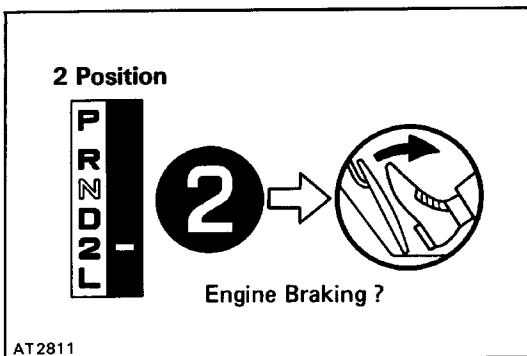
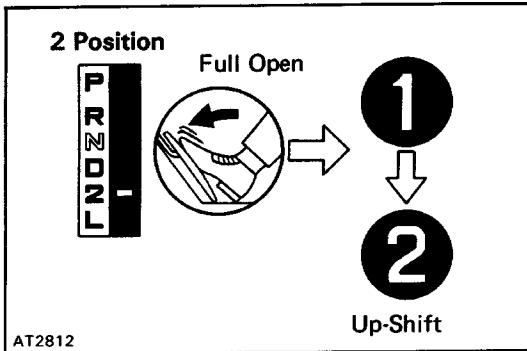
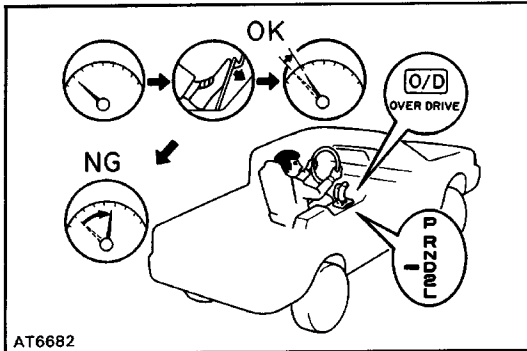
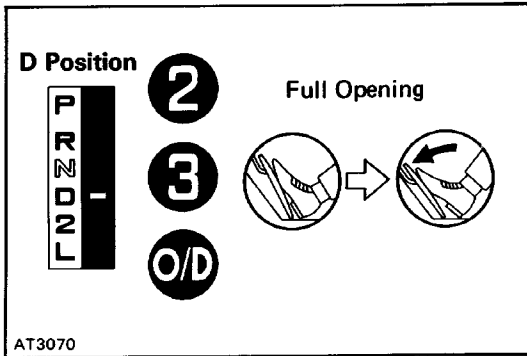

- (d) While running in the D position, 2nd, 3rd and O/D gears, check to see that the possible kick-down vehicle speed limits for 2→1, 3→2 and O/D→3 kick-downs conform to those indicated on the automatic shift schedule.
- (e) Check for abnormal shock and slip at kick-down.

- (f) Check for the lock-up mechanism.
  - (1) Drive in D position, O/D gear, at a steady speed (lock-up ON) of about 75km/h (47mph).
  - (2) Lightly depress the accelerator pedal and check that the engine RPM does not change abruptly. If there is a big jump in engine rpm, there is no lock-up.

**2. 2 POSITION TEST**

Shift into the 2 position and, while driving with the accelerator pedal held constantly at the full throttle valve opening position, push in one of the pattern selectors and check on the following points.

- (a) Check to see that the 1 → 2 up-shift takes place and that the shift point conforms to it shown on the automatic shift schedule.

**HINT:**

There is no O/D up-shift and lock-up in the 2 position. To prevent overrun, the transmission up-shifts into 3rd gear at around 100 km/h (62 mph) or more.

- (b) While running in the 2 position and 2nd gear, release the accelerator pedal and check the engine braking effect.

**EVALUATION**

If there is no engine braking effect:  
Second coast brake is defective

- (c) Check for abnormal noise at acceleration and deceleration, and for shock at up-shift and down-shift.

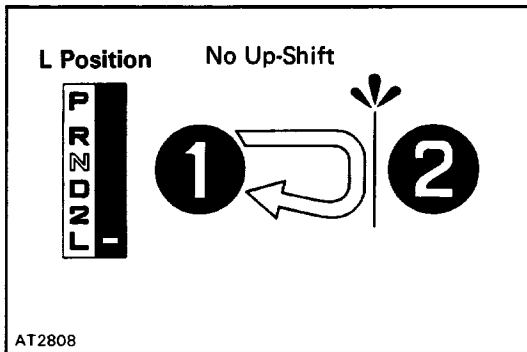

**3. L POSITION TEST**

(a) While running in the L position, check to see that there is no up-shift to 2nd gear.

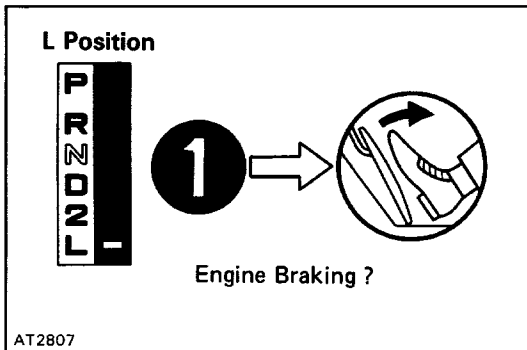

(b) While running in the L position, release the accelerator pedal and check the engine braking effect.

**EVALUATION**

If there is no engine braking effect:

- First and reverse brake is defective

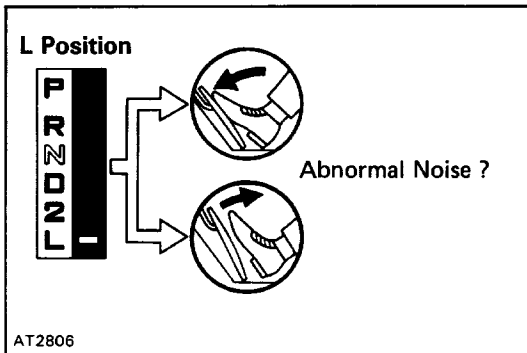

(c) Check for abnormal noise during acceleration and deceleration.

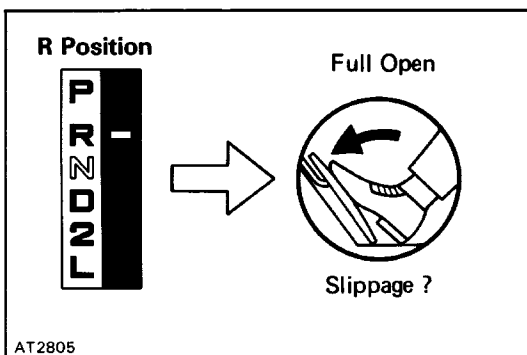

**4. R POSITION TEST**

Shift into the R position and, while starting at wide open throttle, check for slippage.

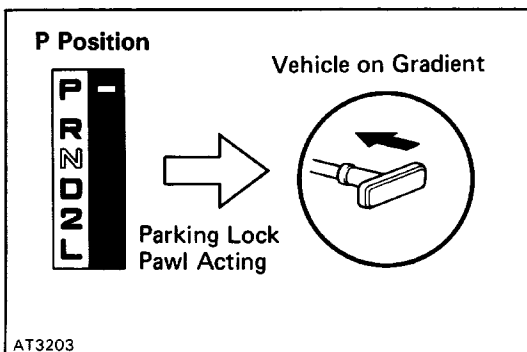

**5. P POSITION TEST**

Stop the vehicle on a gradient (more than 50) and after shifting into the P position, release the parking brake. Then check to see that the parking lock pawl holds the vehicle in place.

# Automatic Shift Schedule

		Throttle valve fully open						[ ] Fully closed		km/h (mph)	
		1→2	2→3	3→O/D	{3→O/D}	{O/D→3}	O/D→3	3→2	2→1		
D position	NORM	44-48 (27-30)	93-99 (58-61)	134-141 (83-87)	35-39 (22-24)	21-25 (13-16)	128-135 (79-84)	87-94 (54-58)	40-43 (25-27)		
	PW R	47-51 (29-32)	93-99 (58-61)	148-155 (92-96)	50-53 (31-33)	21-25 (13-16)	143-149 (89-92)	87-94 (54-58)	41-45 (25-28)		
2 position	NORM PW R	43-46 (27-29)	103-109 (64-68)	-	-	-	-	97-103 (60-64)	38-42 (24-26)		
L position	NORM PW R	-	-	-	-	-	-	82-89 (51-55)	47-51 (29-32)		

		Throttle valve opening 5%						km/h (mph)	
		Lock-up ON			Lock-up OFF				
		2nd	*3rd	O/D	2nd	*3rd	O/D		
D position	NORM	-	41-45 (25-28)	59-63 (37-39)	-	38-42 (24-26)	55-59 (34-37)		
	PWR	-	55-59 (34-37)	75-79 (47-49)	-	50-53 (31-33)	70-73 (43-45)		

\* : O/D switch OFF

**HINT:**

- (1) Lock-up will not occur in 2nd gear unless the throttle valve opening is greater than 50%.
- (2) There is no lock-up in the 2 and L positions.
- (3) In the following cases, the lock-up will be released regardless of the lock-up pattern.
  - When the throttle is completely closed.
  - When the brake light switch is ON.

## Park/Neutral Position Switch

### INSPECTION OF PARK/NEUTRAL POSITION SWITCH

Inspect that there is continuity between each terminals.

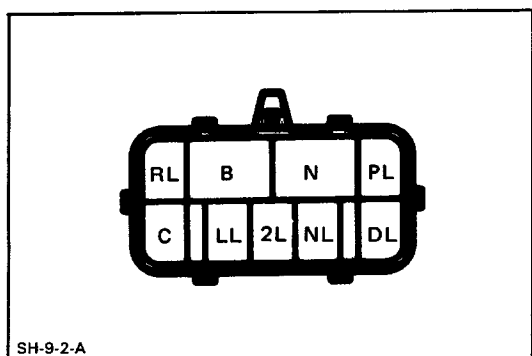

Terminal Shift Position	B	N	PL	RL	NL	DL	2L	LL	C
P	○—○	○—○	○—○						○—○
R				○—○					○—○
N	○—○	○—○			○—○				○—○
D						○—○			○—○
2							○—○		○—○
L								○—○	○—○



# ON-VEHICLE REPAIR

## Valve Body

### REMOVAL OF VALVE BODY

#### 1. CLEAN TRANSMISSION EXTERIOR

To prevent contamination, clean the exterior of the transmission.

#### 2. DRAIN TRANSMISSION FLUID

Remove the drain plug and the fluid into a suitable container.

#### 3. REMOVE OIL PAN

**NOTICE:** Some fluid will remain in the oil pan . Be careful not to damage the filler tube and O-ring.

(a) Remove the nineteen bolts.

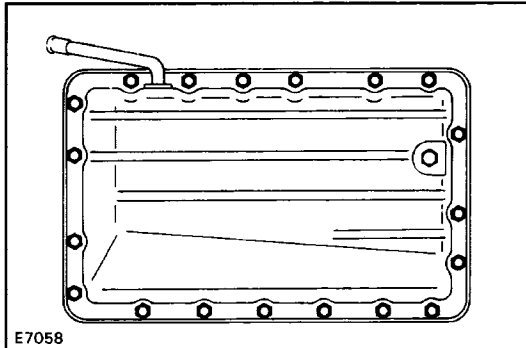

(b) Install the blade of SST between the transmission case and oil pan, cut off applied sealer and then remove the oil pan.

SST 09032-00 100

**NOTICE:** When removing the oil pan, be careful not to damage the oil pan flange.

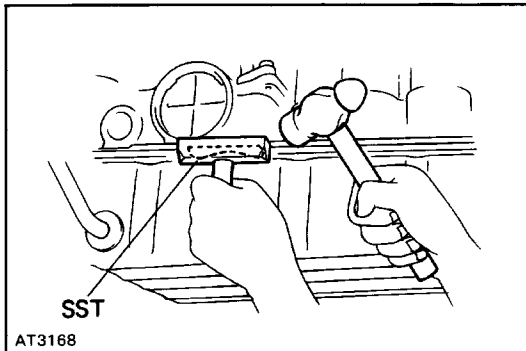

#### 4. REMOVE OIL STRAINER AND GASKETS

(a) Remove the eleven bolts holding the oil strainer to the oil strainer case.

(b) Remove the oil strainer and gasket.

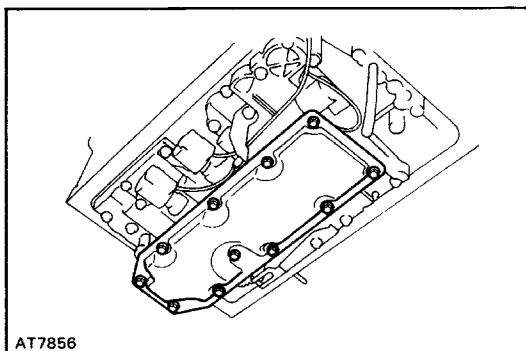

(c) Remove the five bolts and oil strainer case.

(d) Remove the two gaskets from the case.

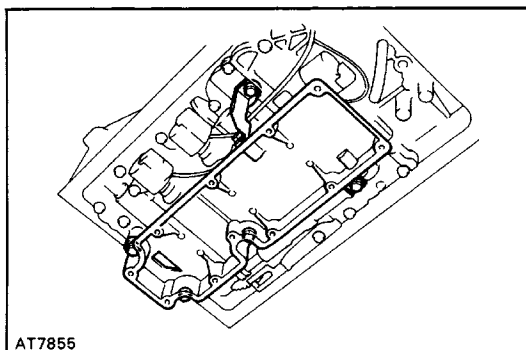

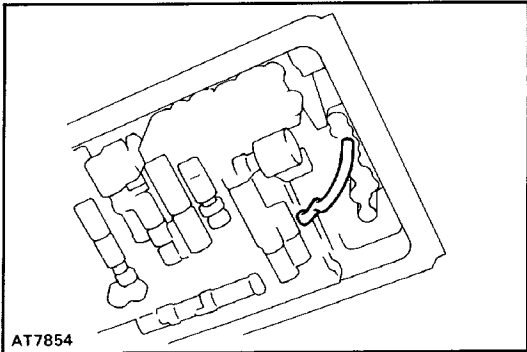

**5. REMOVE OIL TUBE**

Pry up both tube ends with a large screwdriver and remove the tube.

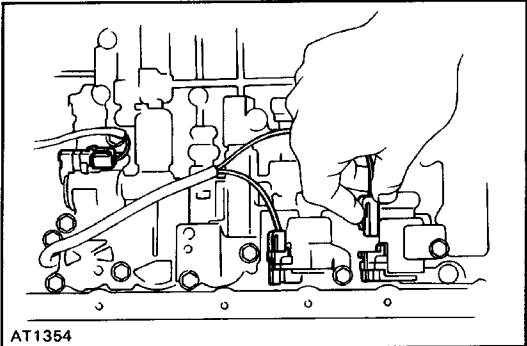

**6. REMOVE SOLENOID WIRING**

(a) Disconnect the three connectors from No.1, No.2 and lock-up solenoids.

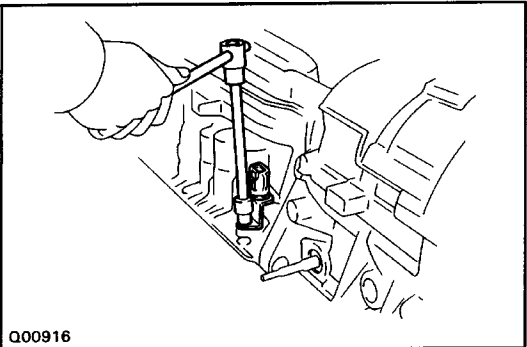

- (b) Remove the stopper plate from the case.
- (c) Pull out the solenoid wiring from the transmission case.
- (d) Remove the O-ring from the grommet.

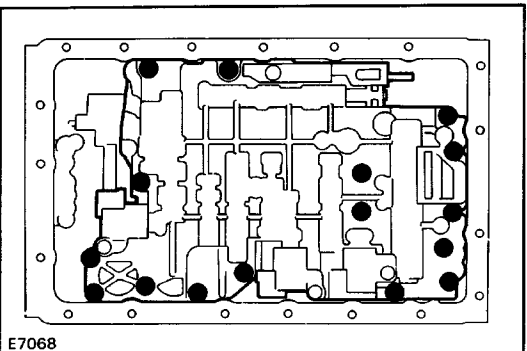

**7. REMOVE VALVE BODY**

(a) Remove the sixteen bolts.

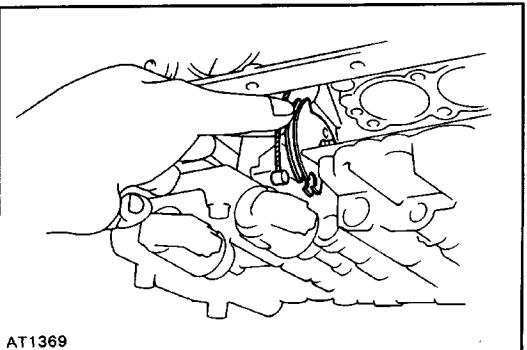

(b) Disconnect the throttle cable from the cam and remove the valve body.

**INSTALLATION OF VALVE BODY**

**1. CONNECT THROTTLE CABLE TO CAM**

Push the cable fitting into the cam.

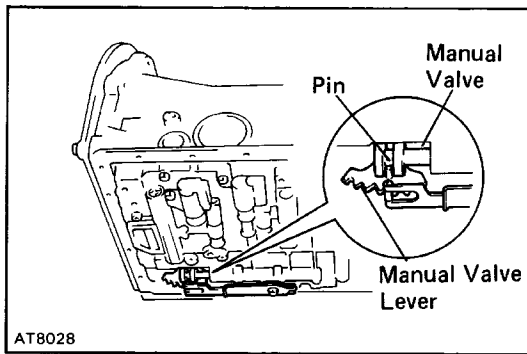

## 2. INSTALL VALVE BODY

(a) Align the manual valve lever with the manual valve.

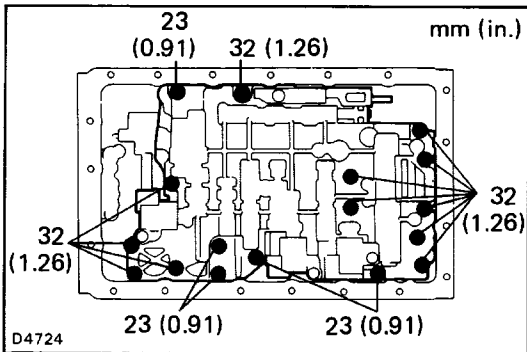

(b) Finger tighten the all bolts first. Then tighten the bolts evenly.

HINT: Each bolt length (mm, in.) is indicated in the figure.

**Torque: 10 N-m (100 kgf-cm, 7 ft-lbf)**

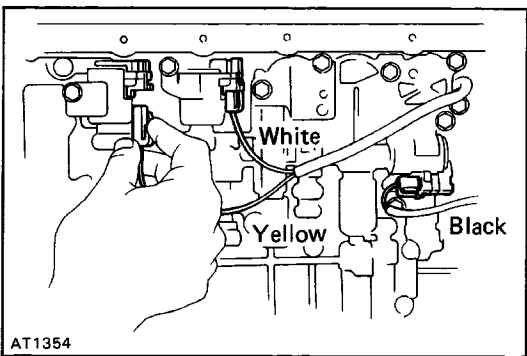

## 3. CONNECT SOLENOID WIRING

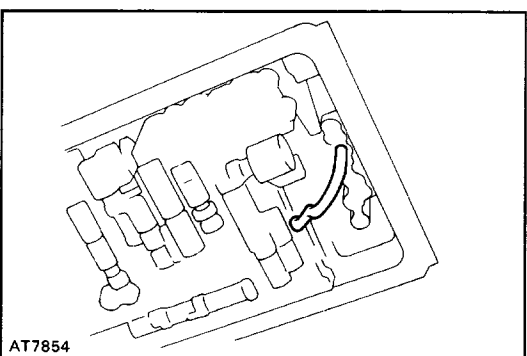

## 4. INSTALL OIL TUBE

Tap the tubes with a plastic hammer to install the tube into the position shown in the figure.

**NOTICE: Be careful not to bend or damage the tube.**

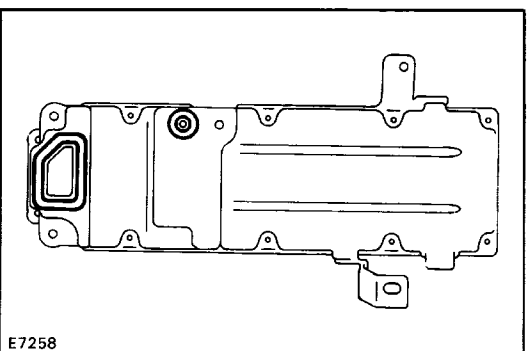

## 5. INSTALL OIL STRAINER AND GASKETS

(a) Install two new gaskets to the oil strainer case.

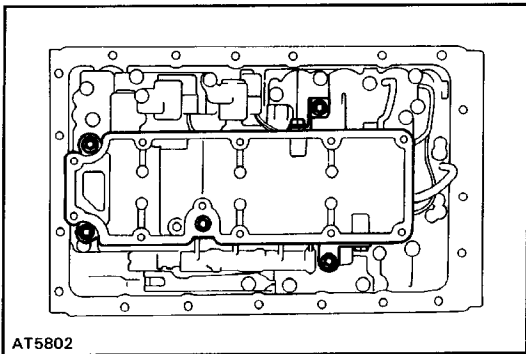

(b) Install the oil strainer case and torque the five bolts.

**Torque: 10 N-m (100 kgf-cm, 7 ft-lbf)**

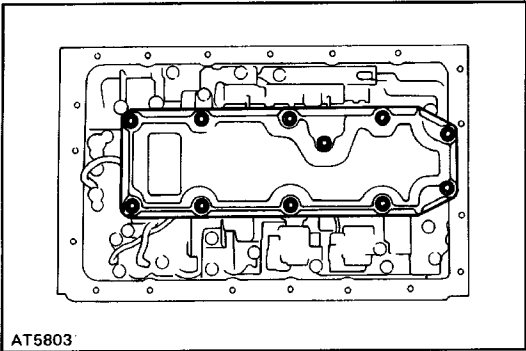

(c) Install a new gasket to the oil strainer case.

(d) Install the oil strainer and torque the eleven bolts.

**Torque: 6.9 N-m (70 kgf-cm, 61 in.-lbf)**

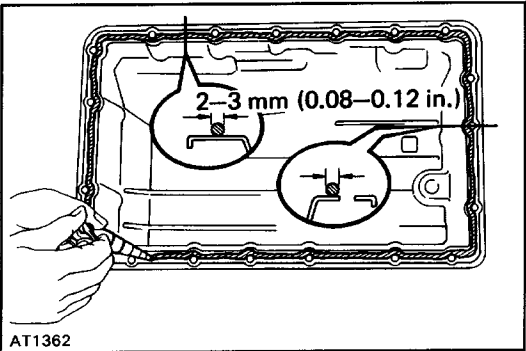

## 6. INSTALL OIL PAN

(a) Remove any packing material and be careful not to drop oil on the contacting surfaces of the transmission case and oil pan.

(b) Apply seal packing to the oil pan shown in the figure.

Seal packing: Part No. 08826-00090, THREE BOND 1281 or equivalent

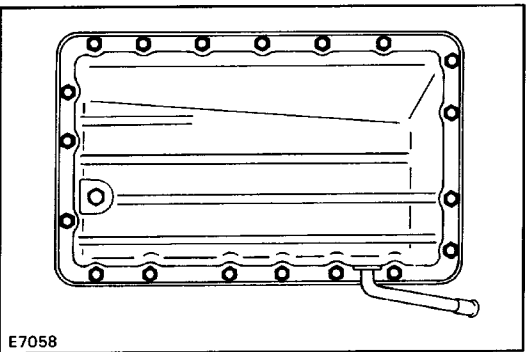

(c) Install and torque the nineteen bolts.

**Torque: 7.4 N-m (75 kgf-cm, 65 in.-lbf)**

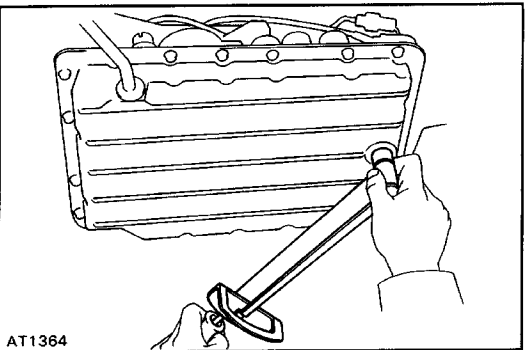

## 7. INSTALL DRAIN PLUG

Torque the drain plug.

**Torque: 20 N-m (205 kgf-cm, 15 ft-lbf)**

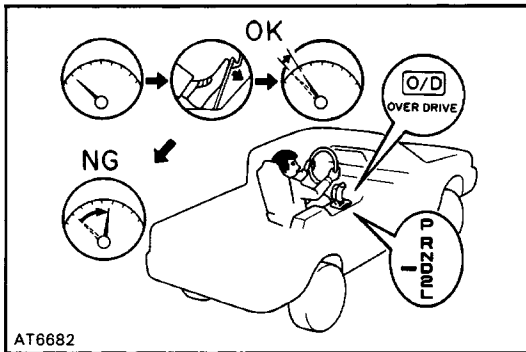

AT6682

## 8. FILL TRANSMISSION WITH ATF

Add only about two liters of ATF. Start the engine and shift through all the positions. Check the fluid level and add as necessary.

**NOTICE:** Do not overfill.

Fluid type: ATF DEXRON®

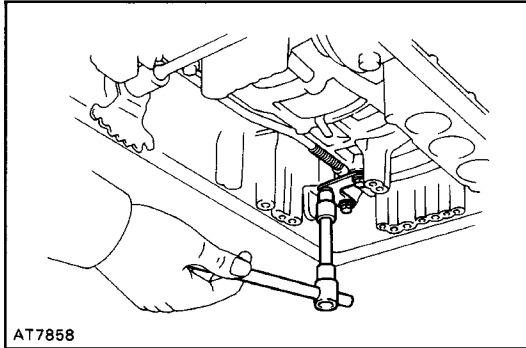

AT7858

## Parking Lock Pawl

### REMOVAL OF PARKING LOCK PAWL

1. REMOVE VALVE BODY (See page [AT-204](#))
  2. REMOVE PARKING LOCK PAWL BRACKET
- Remove the three bolts and the bracket.

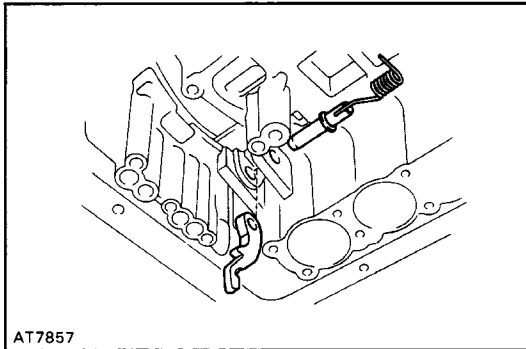

AT7857

### 3. REMOVE SPRING FROM PARKING LOCK PAWL PIVOT PIN

### 4. REMOVE PIVOT PIN AND PARKING LOCK PAWL INSTALLATION OF PARKING LOCK PAWL

1. INSTALL PARKING LOCK PAWL AND PIVOT PIN
2. INSTALL SPRING

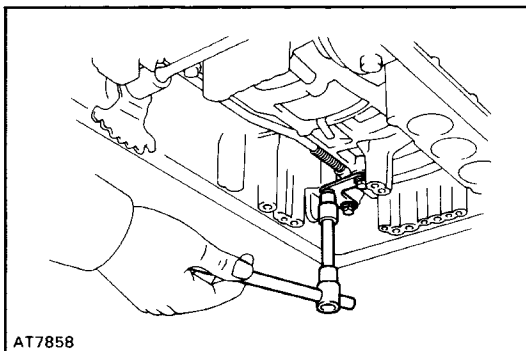

AT7858

### 3. INSTALL PARKING LOCK PAWL BRACKET

- (a) Push lock rod fully toward.
- (b) Install the three bolts finger tight.
- (c) Check that the pawl operates smoothly.
- (d) Torque the bolts.

Torque: 7.4 N-m (75 kgf-cm, 65, in.-lbf)

### 4. INSTALL VALVE BODY (See page [AT-204](#))

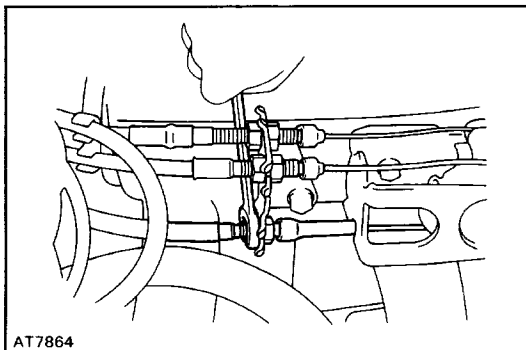

AT7864

## Throttle Cable

### REMOVAL OF THROTTLE CABLE

#### 1. DISCONNECT THROTTLE CABLE

Disconnect the cable from the throttle linkage.

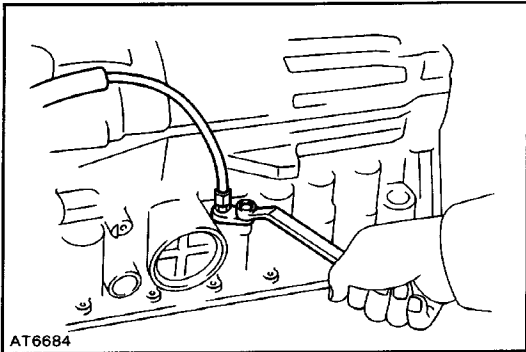

2. REMOVE VALVE BODY (See page [AT-204](#))
3. PUSH THROTTLE CABLE OUT OF TRANSMISSION CASE  
Remove the retaining bolt and pull out the throttle cable.

#### INSTALLATION OF THROTTLE CABLE

##### 1. INSTALL CABLE IN TRANSMISSION CASE

Install the retaining bolt and push in the throttle cable.

##### 2. INSTALL VALVE BODY (See page [AT-205](#))

##### 3. IF THROTTLE CABLE IS NEW, STAKE STOPPER ON INNER CABLE

- (a) Pull the inner cable lightly until a slight resistance is felt, and hold it.
- (b) Stake the stopper as shown, 0.8 – 1.5 mm (0.031 – 0.059 in.) in width.

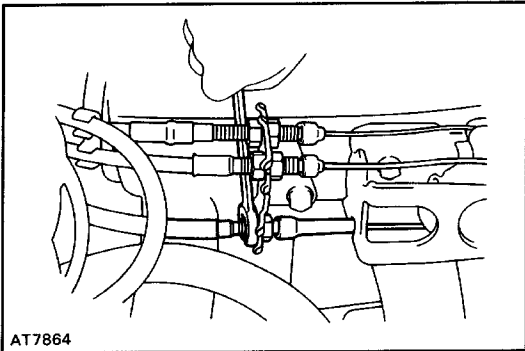
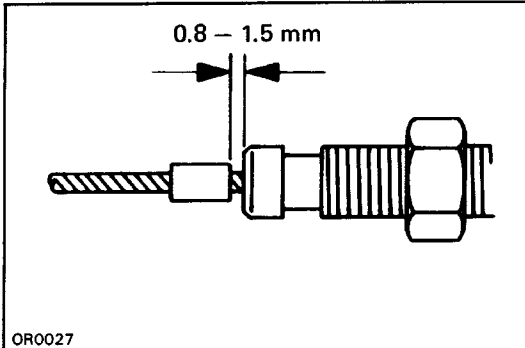

4. CONNECT THROTTLE CABLE
5. ADJUST THROTTLE CABLE (See page [AT-182](#))
6. TEST DRIVE VEHICLE

# REMOVAL AND INSTALLATION OF TRANSMISSION

Remove and Install the parts as shown.

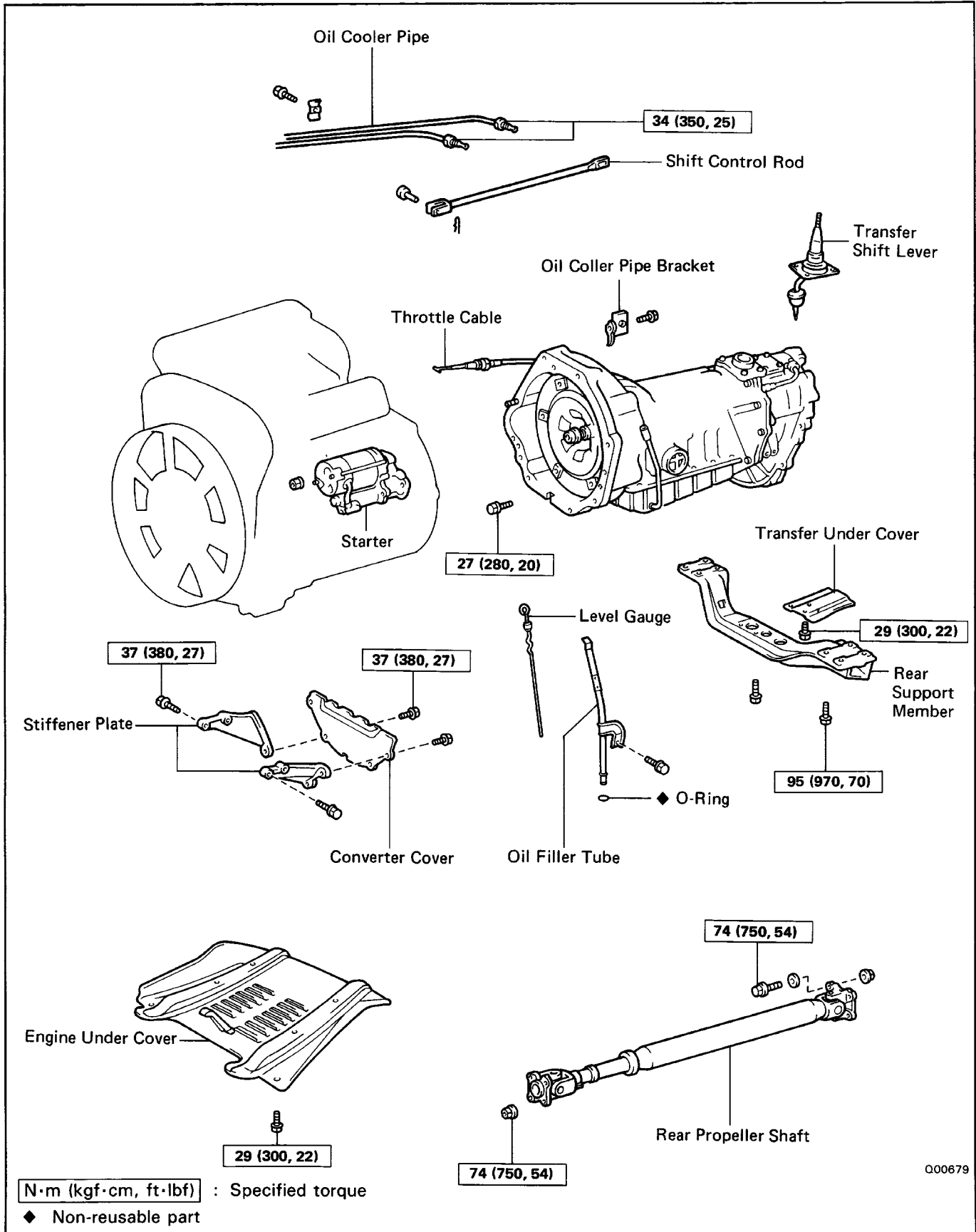

(Cont'd)

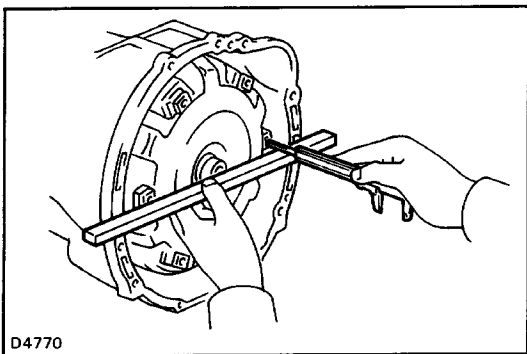
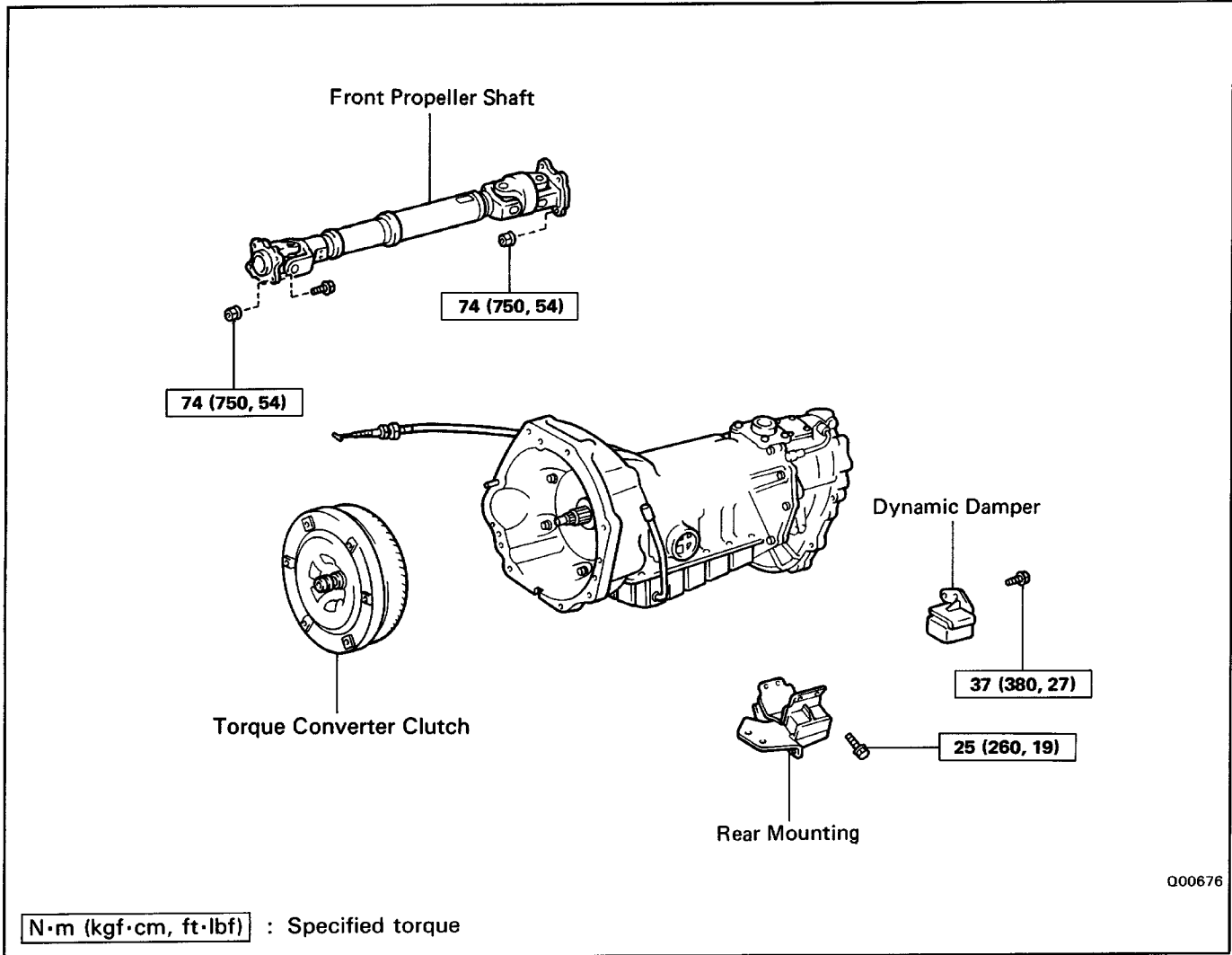

**(MAIN POINT OF INSTALLATION)**

**1. CHECK TORQUE CONVERTER CLUTCH INSTALLATION**

Using calipers and a straight edge, measure from the installed surface of the torque converter clutch to the front surface of the transmission housing.

**Correct distance: 20.0 mm (0.787 in.)**

If the distance is less than the standard, check for an improper installation.

**2. ADJUST TRANSMISSION THROTTLE CABLE**

(See page [AT-182](#))

**3. FILL TRANSMISSION WITH ATF AND CHECK FLUID LEVEL**

Fluid type: ATF DEXRON® II

**NOTICE:** Do not overfill.



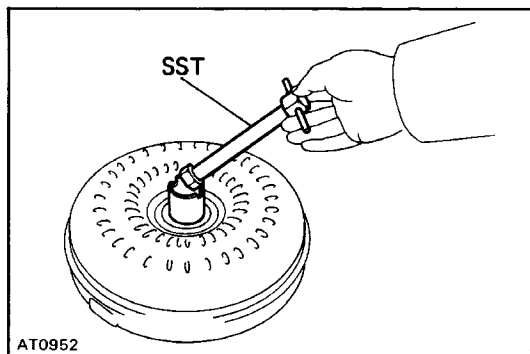

AT0952

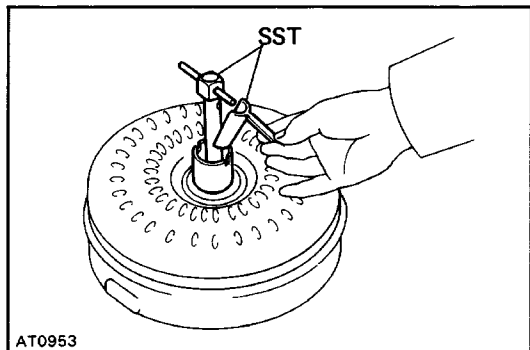

AT0953

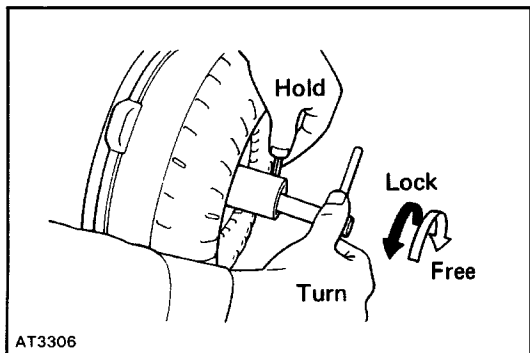

AT3306

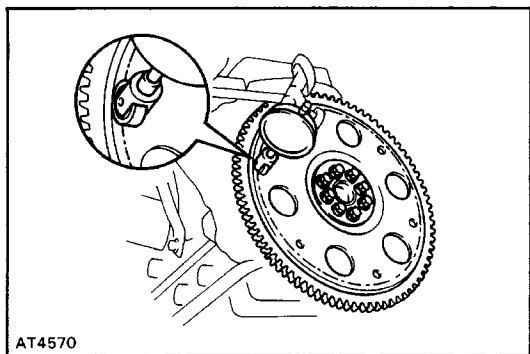

AT4570

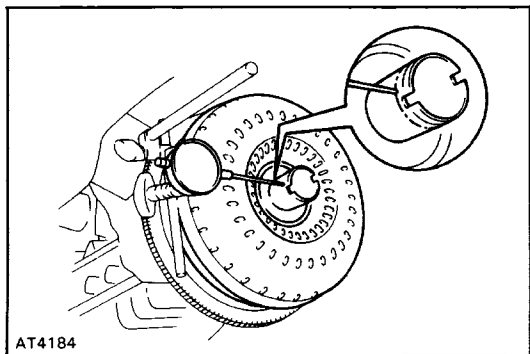

AT4184

# TORQUE CONVERTER CLUTCH AND DRIVE PLATE

## INSPECTION OF TORQUE CONVERTER CLUTCH AND DRIVE PLATE

### 1. INSPECT ONE-WAY CLUTCH

(a) Install SST into the inner race of the one-way clutch.  
SST 09350-30020 (09351-32010)

(b) Install SST so that it fits in the notch of the converter hub and outer race of the one-way clutch.  
SST 09350-30020 (09351-32020)

(c) With the torque converter clutch standing on its side, the clutch locks when turned counterclockwise, and rotates freely and smoothly clockwise. If necessary, clean the converter and retest the clutch.  
Replace the converter if the clutch still fails the test.

### 2. MEASURE DRIVE PLATE RUNOUT AND INSPECT RING GEAR

Set up a dial indicator and measure the drive plate runout.

If runout exceeds 0.20 mm (0.0079 in.) or if the ring gear is damaged, replace the drive plate. If installing a new drive plate, note the orientation of spacers and tighten the bolts.

**Torque: 83 N-m (850 kgf-cm, 61 ft-lbf)**

### 3. MEASURE TORQUE CONVERTER CLUTCH SLEEVE RUNOUT

(a) Temporarily mount the torque converter clutch to the drive plate. Set up a dial indicator.  
If runout exceeds 0.30 mm (0.0118 in.), try to correct by reorienting the installation of the converter. If excessive runout cannot be corrected, replace the torque converter clutch.

**HINT:** Mark the position of the converter to ensure correct installation.

(b) Remove the torque converter clutch.

# SHIFT LOCK SYSTEM

## (Electrically Controlled Shift Lock System)

### COMPONENTS AND CIRCUIT

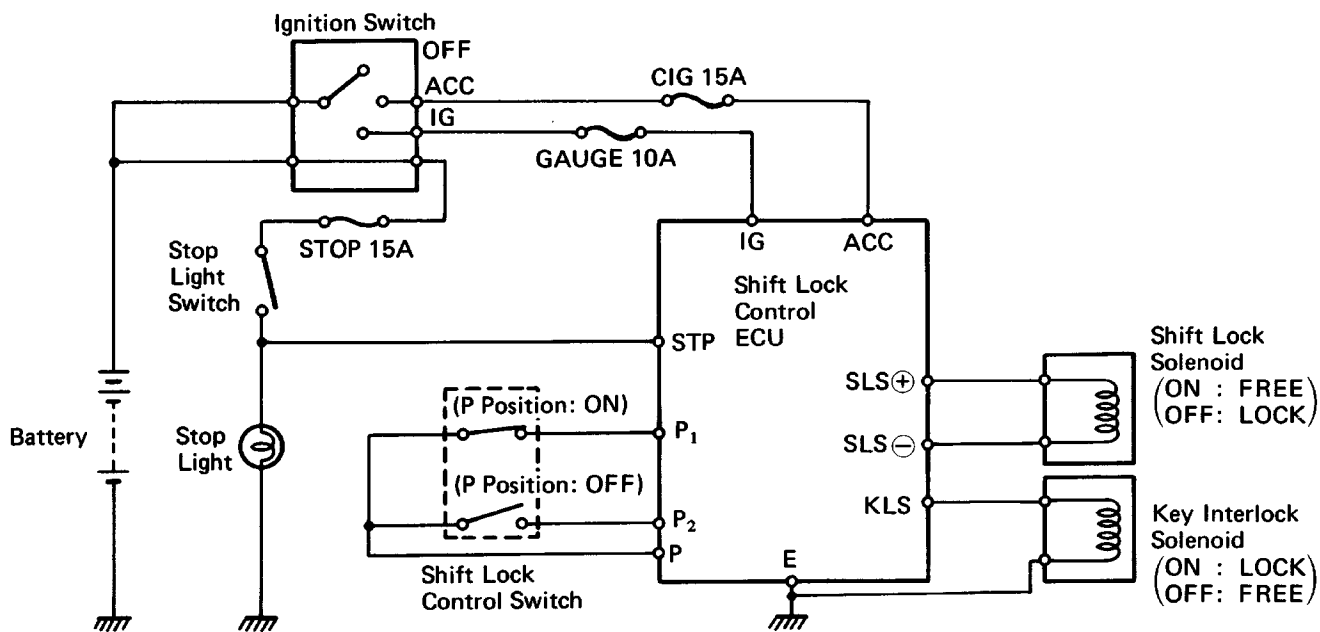
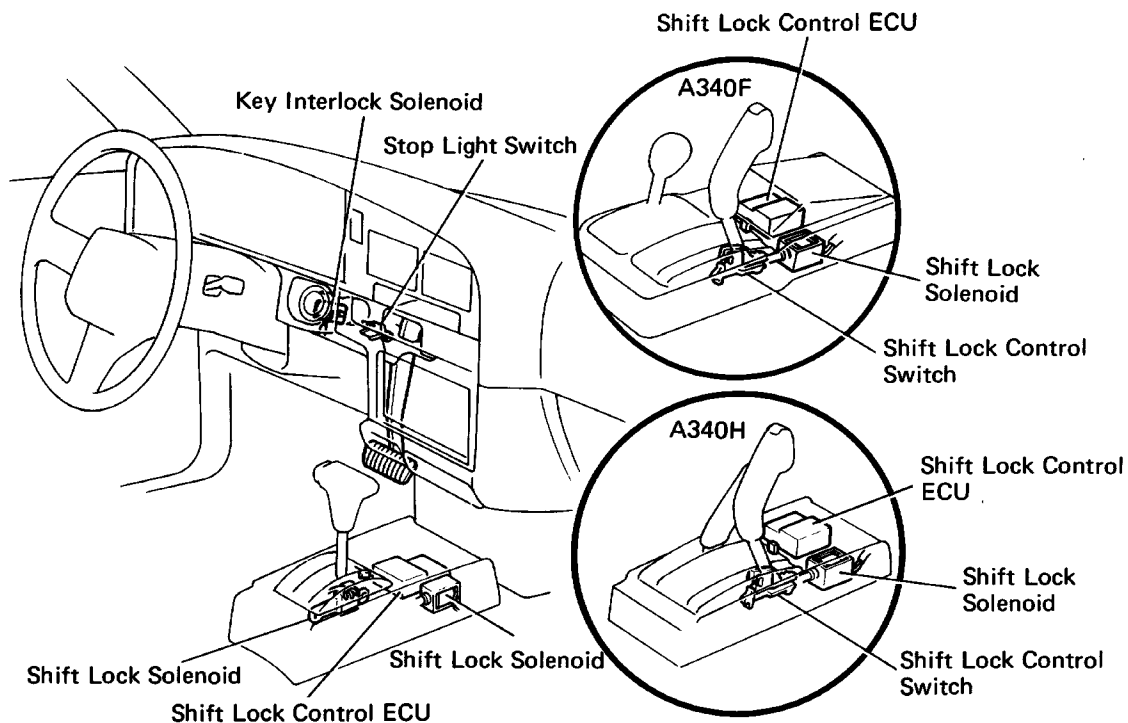

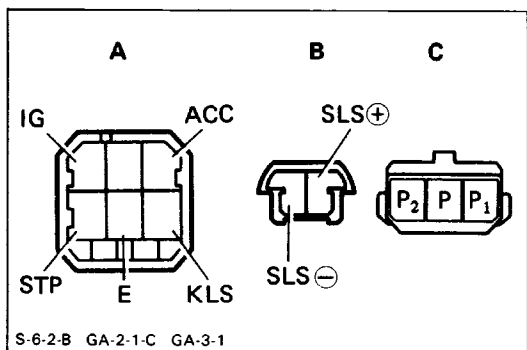

**INSPECTION OF ELECTRIC CONTROL COMPONENTS**

**1. INSPECT SHIFT LOCK CONTROL COMPUTER**

Using a voltmeter, measure the voltage at each terminal.

Connector	Terminal	Measuring condition	Voltage (V)	
A	ACC - E	IG SW ACC position	10 - 14	
	IG - E	• G SW ON position	10 - 14	
	STP - E	Depress brake pedal	10 - 14	
	KLS - E	①	IG SW ACC position and P position	0
		②	P → R, N, D, 2, L position	10 - 14
③		↑ (Approx. after one second)	6 - 9	
B	SLS ⊕ - SLS ⊖	①	IG SW ON position and P position	0
		②	Depress brake pedal	10 - 14
		③	P → R, N, D, 2, L positions or release brake pedal	0
C	P <sub>1</sub> - P	①	IG SW ON, P position and depress brake pedal	0
		②	R, N, D, 2, L positions	10 - 14
	P <sub>2</sub> - P	①	IG SW ACC position and P position	10 - 14
		②	R, N, D, 2, L positions	0

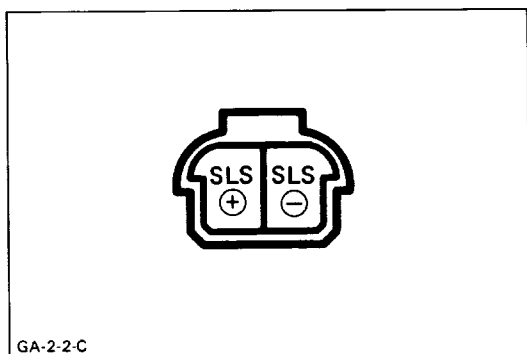

**2. INSPECT SHIFT LOCK SOLENOID**

- (a) Disconnect the solenoid connector.
- (b) Using an ohmmeter, measure the resistance between terminals.  
Standard resistance: 29 - 36/
- (c) Apply the battery positive voltage between terminals. At this time, confirm that a solenoid operation

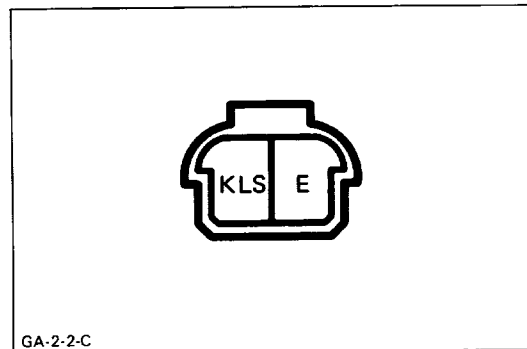

**3. INSPECT KEY INTERLOCK SOLENOID**

- (a) Disconnect the solenoid connector.
- (b) Using an ohmmeter, measure the resistance between terminals.  
Standard resistance: 12 - 17/
- (c) Apply the battery positive voltage between terminals. At this time, confirm that a solenoid operation

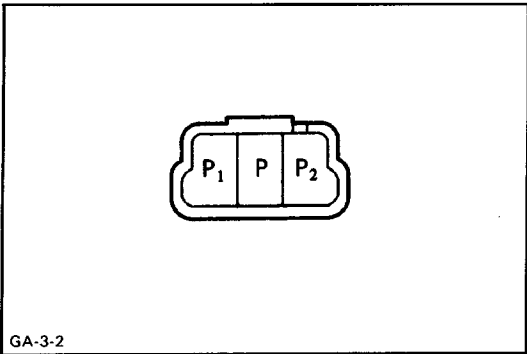

**4. INSPECT SHIFT LOCK CONTROL SWITCH**

Inspect that there is continuity between each terminals.

: Continuity

Shift Position	Terminal		
	P	P <sub>1</sub>	P <sub>2</sub>
P position (Release button is not pushed)	○—○		
R, N, D, 2, L positions	○	—	○

**(Mechanically Controlled Shift Lock System)**

**COMPONENTS**

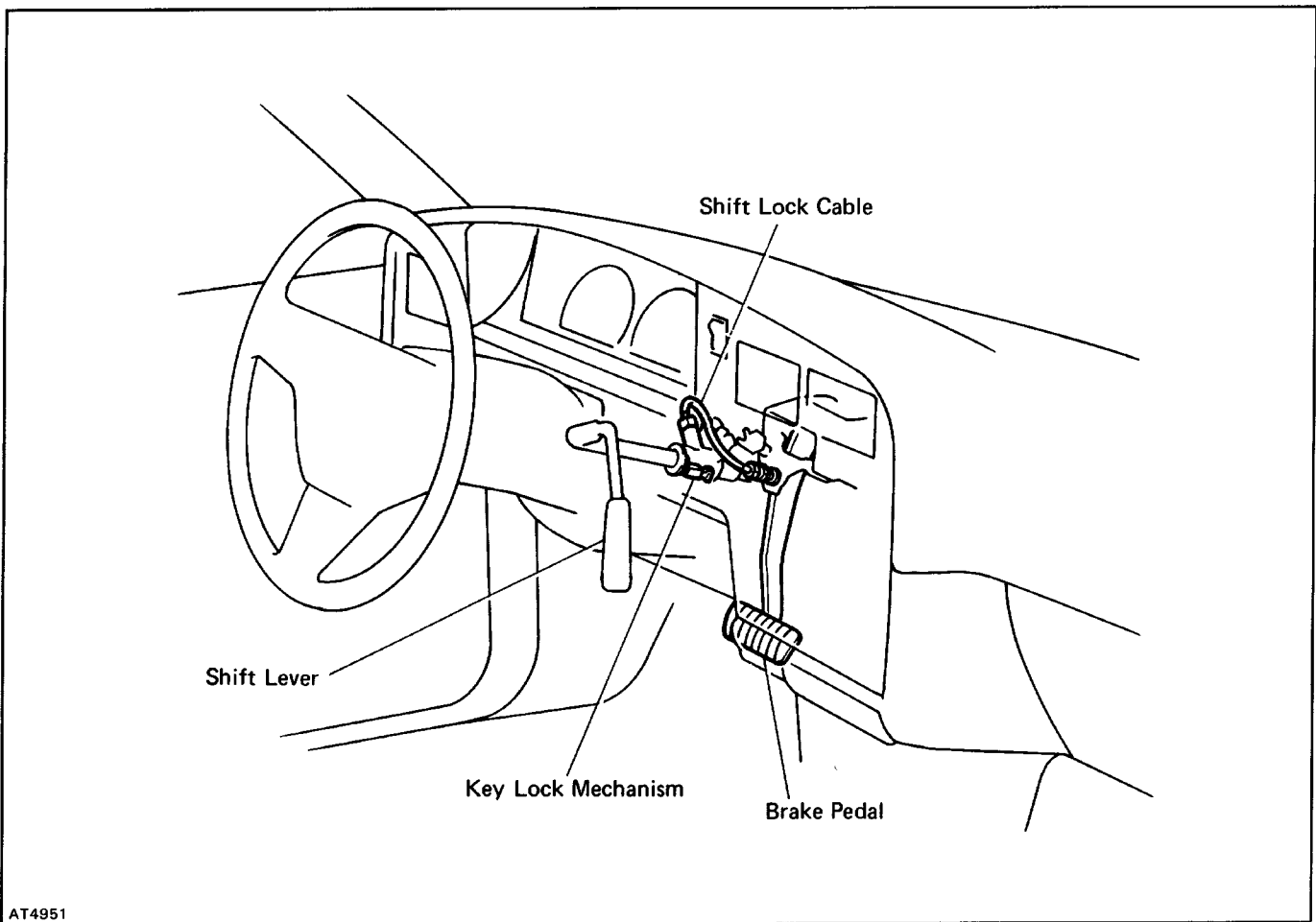

HINT: Do the following steps, after replacing the shift-lever, ignition switch, shift lock cable and brake pedal.

- (a) Check that the stop lights turn on while depressing the brake pedal.
- (b) Check that the stop lights turn off when releasing the brake pedal.

If stop light operation is not as specified, adjust the stop light switch position.

# TRANSFER

# DESCRIPTION

## TRANSFER

The Transfer transmits the drive force from the transmission to the front wheels, switching between 2WD, 4WD (High) and 4WD (Low).

In the Truck the types of gear used during deceleration produce 2 types of transfer.

The specifications and cross-section diagrams are as shown.

**RF1A Type Transfer**

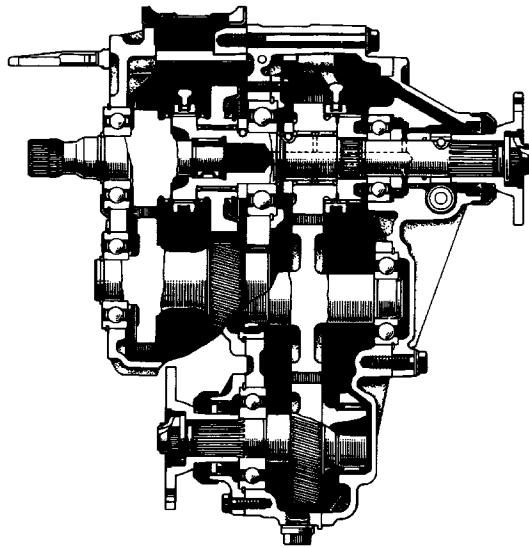

**VF1A Type Transfer**

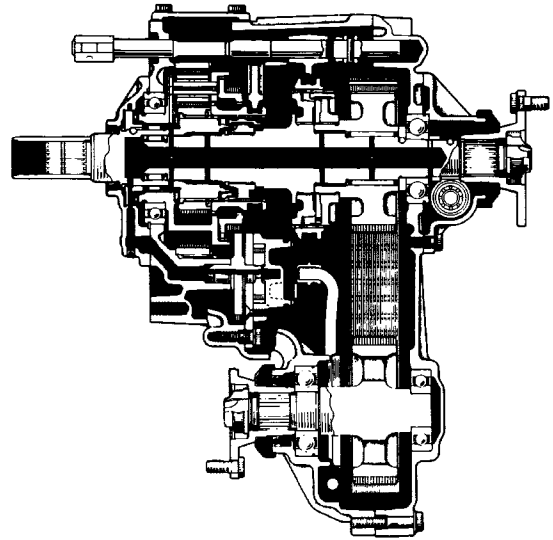

E9702 TF0637

## Specification

Transfer		RF1A Type Transfer	VF1A Type Transfer	
Items				
Type of Engine		22R-E	22R-E	3VZ-E
Type of Transmission		W56	G58, *A340F	R150F
Type of Reduction Gear		Counter Gear	Planetary Gear	
Gear Ratio	H2 and H4	1.000	1.000	
	L4	2.276	2.566	
Oil Capacity liters (US qts., Imp. qts.)		1.6 (1.7, 1.4)	1.1 (1.2, 1.0)	
Oil Grade		API GL-4 or GL-5	API GL-4 or GL-5	
Oil Viscosity		SAE 75W-90	SAE 75W-90	

Automatic Transmission

## PRECAUTIONS

When working with FIPG material, you must observe the following.

- Using a razor blade and gasket scraper, remove all the old packing (FIPG) material from the gasket surfaces.
- Thoroughly clean all components to remove all the loose material.
- Clean both sealing surfaces with a non-residue solvent.
- Apply the seal packing in approx. 1 mm (0.04 in.) bead along the sealing surface.
- Parts must be assembled within 10 minutes of application. Otherwise, the packing (FIPG) material must be removed and reapplied.

## TROUBLESHOOTING

Problem	Possible cause	Remedy	Page
Hard to shift or will not shift	Transfer faulty	Disassemble and inspect transfer	<a href="#">TF-4, 32</a>
Transfer jumps out of gear	Transfer faulty	Disassemble and inspect transfer	<a href="#">TF-4, 32</a>

## REMOVAL OF TRANSFER

### 1. REMOVE TRANSFER WITH TRANSMISSION

MT – See pages MT-14 to 25

AT – See pages [AT-210](#) and 211

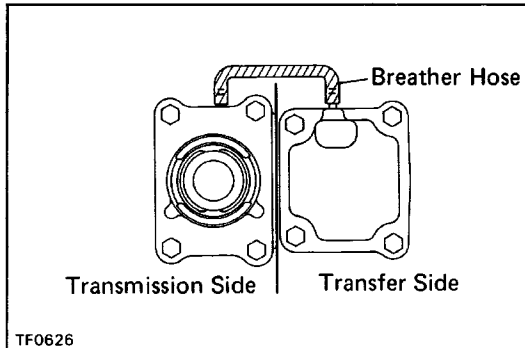

### 2. (22R-E1G58, A340F)

#### REMOVE BREATHER HOSE

Disconnect the breather hose from transfer upper cover and transmission control retainer.

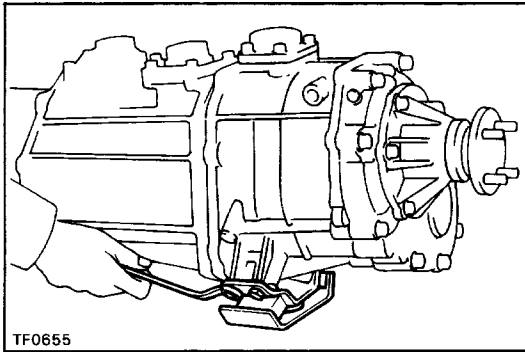

### 3. REMOVE ENGINE REAR MOUNTING

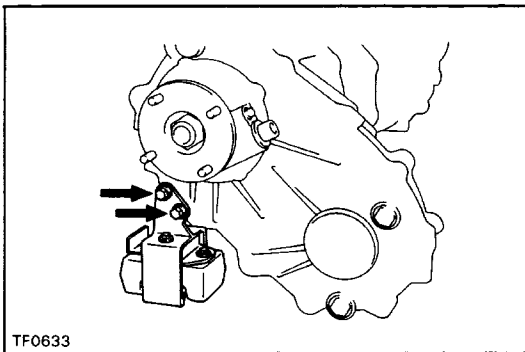

### 4. (Regular Cab w/ VF1A Type Transfer)

#### REMOVE DYNAMIC DAMPER

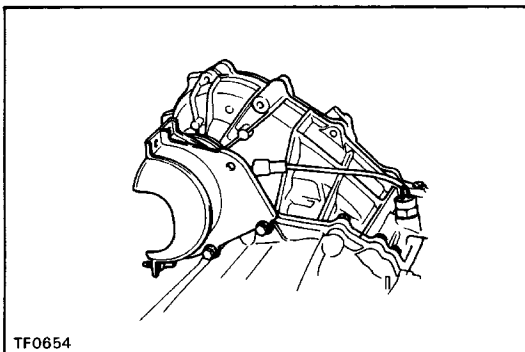

### 5. REMOVE PROPELLER SHAFT UPPER DUST COVER AND TRANSFER FROM TRANSMISSION

(a) Remove the dust cover bolt from the bracket.

(b) Remove the transfer adaptor rear mounting bolts.

(c) Pull the transfer straight up and remove it from the transmission.

HINT: Take care not to damage the adaptor rear oil seal with the transfer input gear spline.



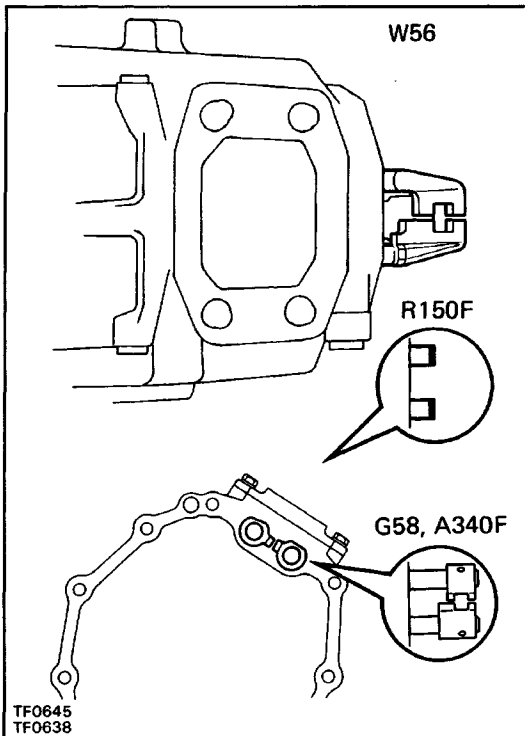

## INSTALLATION OF TRANSFER

### 1. INSTALL TRANSFER AND PROPELLER SHAFT UPPER DUST COVER TO TRANSMISSION WITH NEW GASKET

(a) Shift the two shift fork shafts to the high-four position.

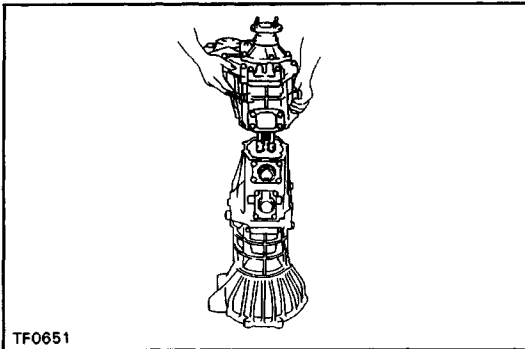

(b) Apply MP grease to the adaptor oil seal.

(c) Place a new gasket to the transfer adaptor.

(d) Install the transfer to the transmission.

HINT: Take care not to damage the oil seal by the input gear spline when installing the transfer.

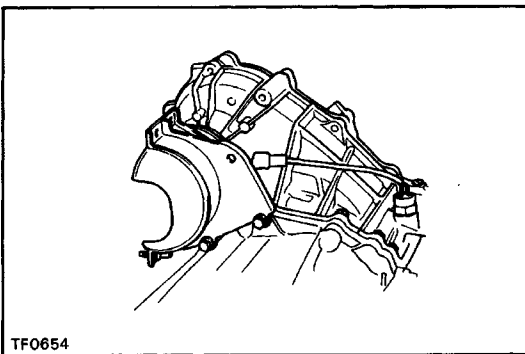

(e) Install and torque the bolts with the propeller shaft upper dust cover.

**Torque:**

**W56 39 N-m (400 kgf-cm, 29 ft-lbf)**

**R 150F, G58, A340F**

**37 N-m (380 kgf-cm, 27 ft-lbf)**

(f) Install the dust cover bolt to the bracket.

**Torque:**

**R 150F, G58, A340F**

**23 N-m (230 kgf-cm, 17 ft-lbf)**

**W56 39 N-m (400 kgf-cm, 29 ft-lbf)**

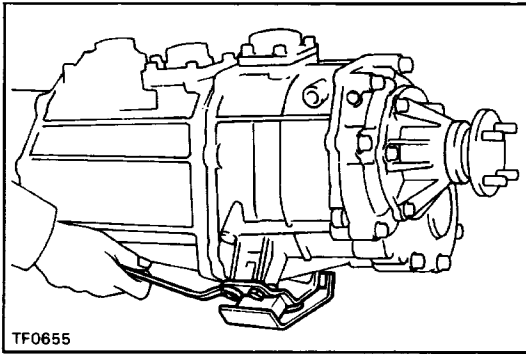

**2. INSTALL ENGINE REAR MOUNTING**  
 Torque: 25 N-m (260 kgf-cm, 19 ft-lbf)

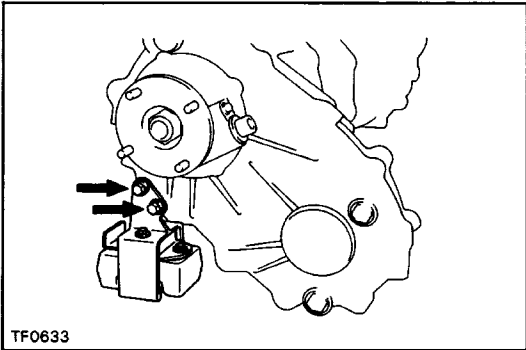

**3. (Regular Cab w/ VF 1 A Type Transfer)**  
**INSTALL DYNAMIC DAMPER**  
 Torque: 37 N-m (380 kgf-cm, 27 ft-lbf)

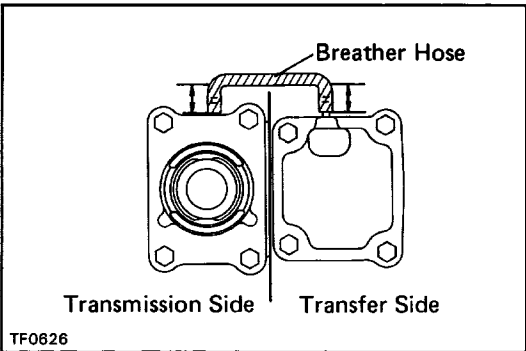

**4. (22R-EIG58, A340F)**  
**INSTALL BREATHER HOSE**

Connect the breather hose for transfer upper cover and transmission control retainer as shown.

**Hose depth: 13 mm (0.51 in.)**

**5. INSTALL TRANSFER WITH TRANSMISSION**

MT – See pages MT-14 to 25.

AT – See pages [AT-210](#) and 211.

**6. FILL TRANSMISSION AND TRANSFER WITH OIL**

MT – See page MT-24.

AT – See page [AT-181](#).

**7. PERFORM ROAD TEST**

Check for abnormal noise and smooth operation.

# (RF1A TYPE TRANSFER) COMPONENTS

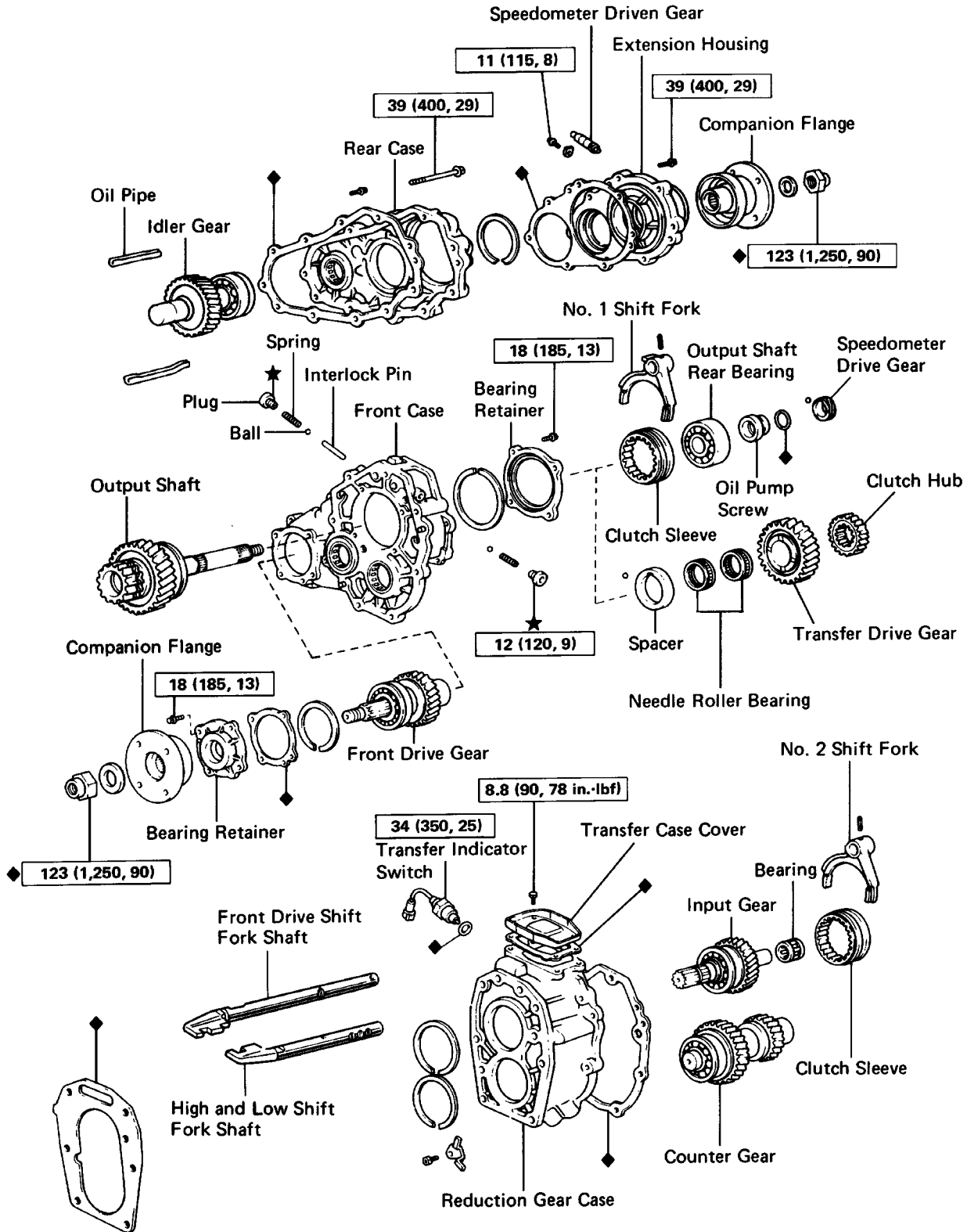

**N·m (kgf·cm, ft·lbf) : Specified torque**

◆ Non-reusable part

★ Precoated part

# DISASSEMBLY OF TRANSFER

(See page [TF-7](#))

1. REMOVE No. 1 SPEED SENSOR
2. REMOVE TRANSFER INDICATOR SWITCH

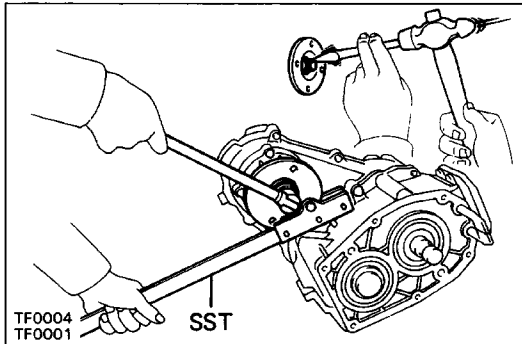

### 3. REMOVE FRONT COMPANION FLANGE

(a) Using a hammer and chisel, loosen the staked part of the nut.

(b) Using SST to hold the flange, remove the nut and washer.

SST 09330-00021

(c) Remove the companion flange.

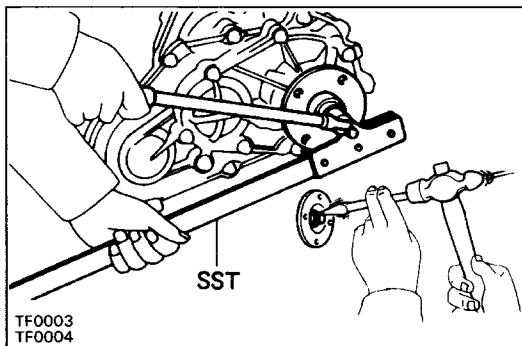

HINT: If the companion flange is difficult to remove, use SST.

### 4. REMOVE REAR COMPANION FLANGE

(a) Using a hammer and chisel, loosen the staked part of the nut.

(b) Using SST to hold the flange, remove the nut and washer.

SST 09330-00021

(c) Remove the companion flange.

### 5. REMOVE EXTENSION HOUSING

Remove the seven bolts and remove the extension housing.

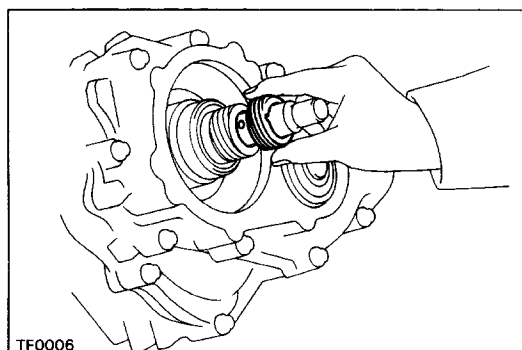
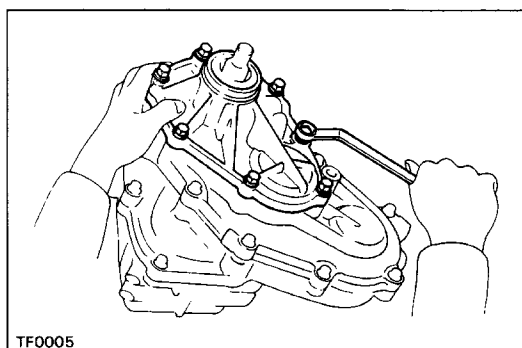

### 6. REMOVE SPEEDOMETER DRIVE GEAR, STEEL BALL, OIL PUMP SCREW AND BEARING

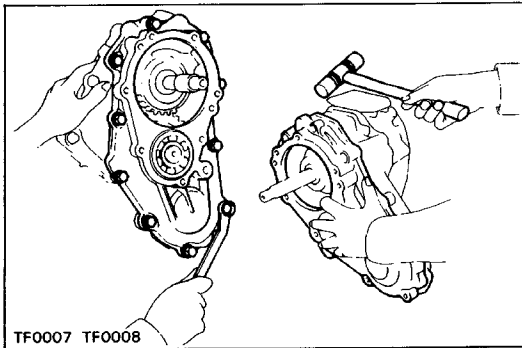

## 7. REMOVE REAR CASE

- (a) Remove the ten bolts.
- (b) Using a plastic hammer, remove the rear case with the idler gear.

HINT: Hold the front case so the rear does not descend. If it descends, the clutch hub and steel ball may fall out.

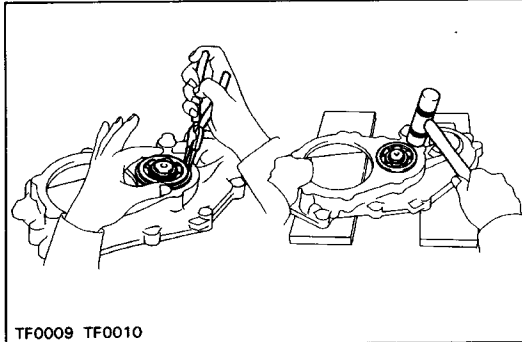

## 8. REMOVE IDLER GEAR FROM REAR CASE

- (a) Using snap ring pliers, remove the snap ring.
- (b) Using a plastic hammer, tap out the idler gear from the rear case.

HINT: Place the rear case on something soft such as wooden blocks.

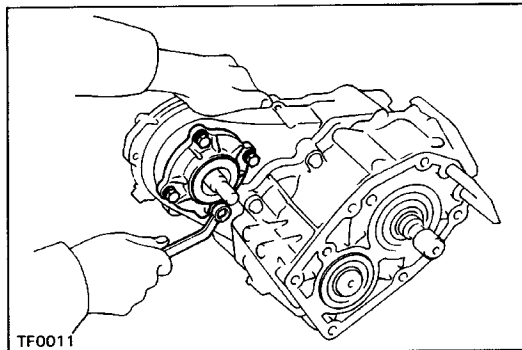

## 9. REMOVE BEARING RETAINER

Remove the four bolts and remove the bearing retainer.

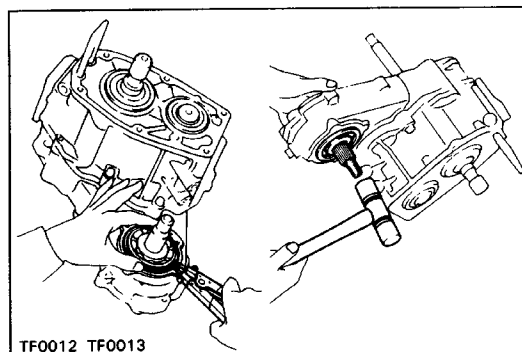

## 10. REMOVE FRONT DRIVE GEAR

- (a) Using snap ring pliers, remove the snap ring.
- (b) Using a plastic hammer, tap out the front drive gear from the front case.

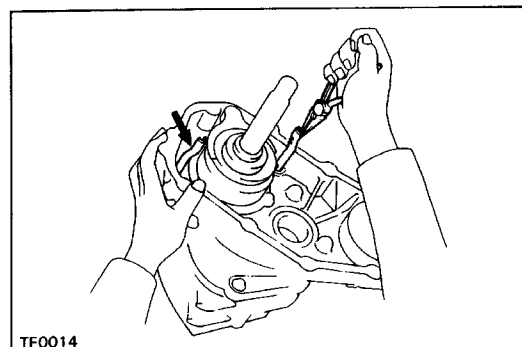

## 11. REMOVE OIL PIPES

Using pliers, remove the two oil pipes.

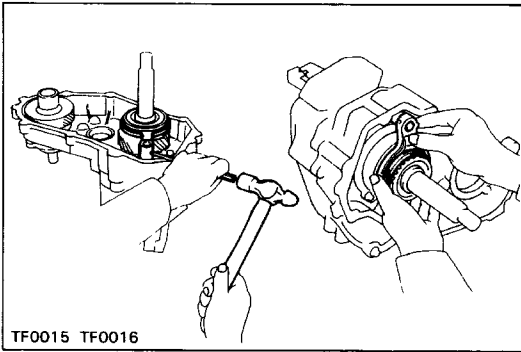

## 12. REMOVE SHIFT NO. 1 FORK AND CLUTCH SLEEVE

- (a) Shift the fork shafts to the high–low position.
- (b) Using a pin punch and a hammer, drive out the slotted spring pin.
- (c) Remove the shift No. 1 fork together with the clutch sleeve.

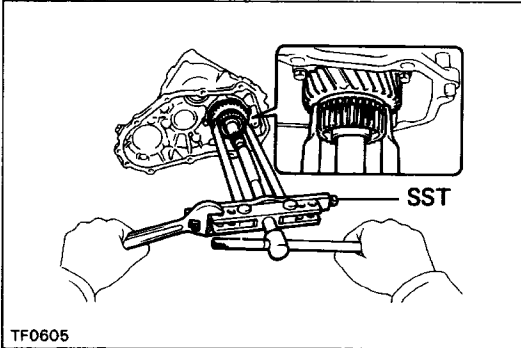

## 13. REMOVE CLUTCH HUB AND TRANSFER DRIVE GEAR

Using SST, remove clutch hub and transfer drive gear.  
SST 09950–20017

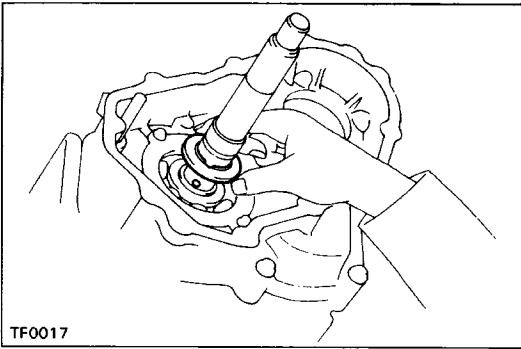

## 14. REMOVE NEEDLE ROLLER BEARING, NO.2 SPACER AND STEEL BALL

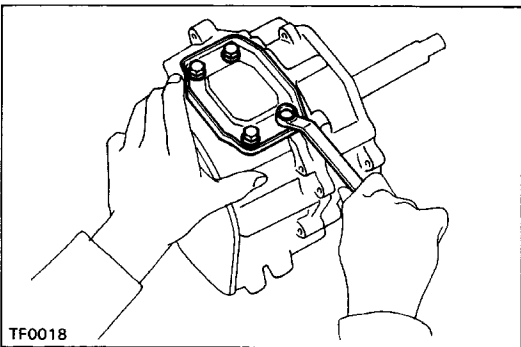

## 15. REMOVE TRANSFER CASE COVER

Remove the four bolts and remove the transfer case cover and gasket.

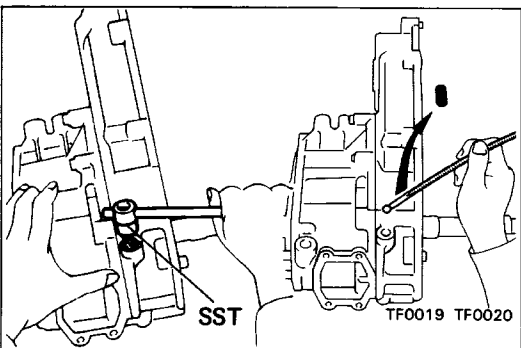

## 16. REMOVE STRAIGHT SCREW PLUGS, SPRINGS AND LOCKING BALLS

- (a) Using SST, remove the plug on the right side.  
SST 09313–30021
- (b) Using a magnetic finger, remove the spring and ball.
- (c) Remove the plug, spring and ball on the left side in the same procedure.

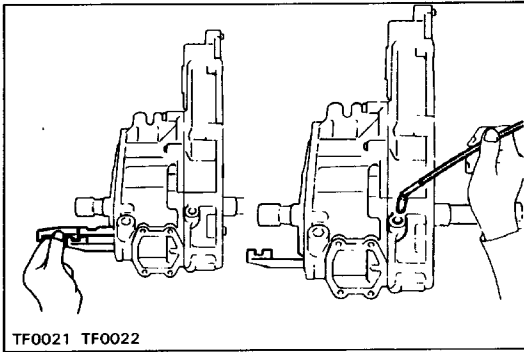
**17. REMOVE FRONT DRIVE SHIFT FORK SHAFT****18. REMOVE INTERLOCK PIN**

Using a magnetic finger, remove the interlock pin.

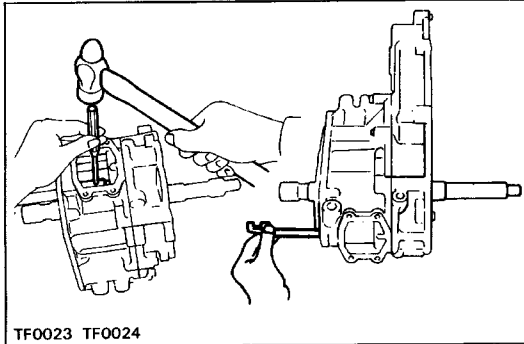
**19. REMOVE HIGH AND LOW SHIFT FORK SHAFT**

(a) Using a pin punch and a hammer, drive out the slotted spring pin.

(b) Remove the shaft.

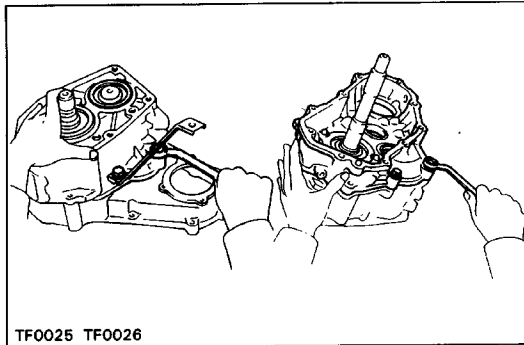
**20. REMOVE FRONT CASE**

(a) Remove the four bolts.

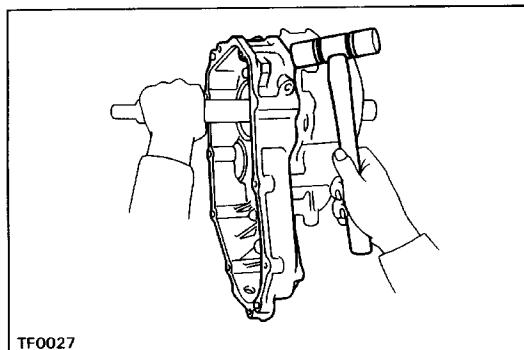

(b) Using a plastic hammer, remove the front case with the output shaft.

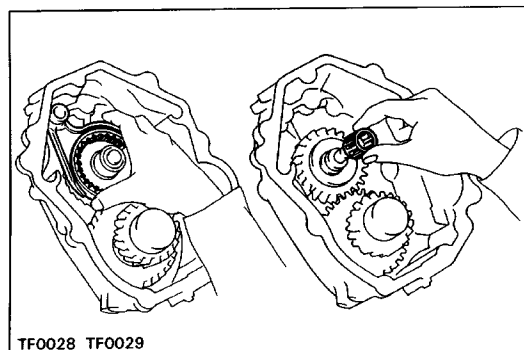
**21. REMOVE NO.2 FORK WITH CLUTCH SLEEVE AND NEEDLE ROLLER BEARING FROM INPUT SHAFT**

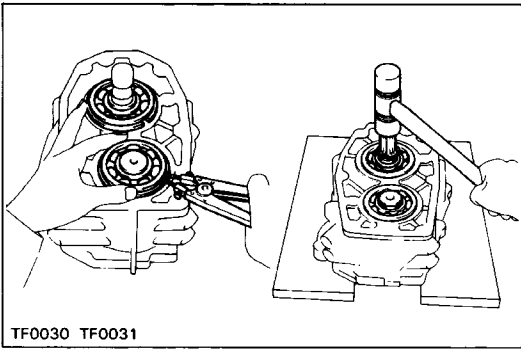

**22. REMOVE INPUT GEAR AND COUNTER GEAR FROM REDUCTION GEAR CASE**

- (a) Using a snap ring pliers, remove the two snap rings.
- (b) Using a plastic hammer, tap out the input gear and counter gear from the reduction gear case.

HINT: Place the reduction gear case on something soft such as wooden blocks.

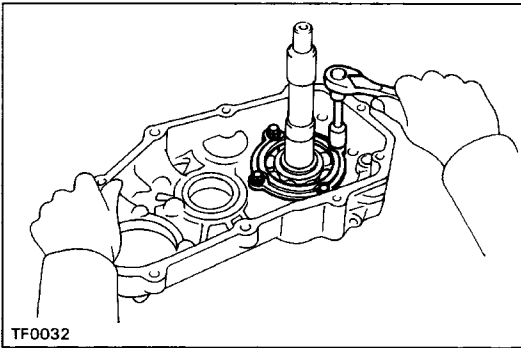

**23. REMOVE OUTPUT SHAFT FROM FRONT CASE**

- (a) Remove the four bearing retainer bolts and remove the bearing retainer.

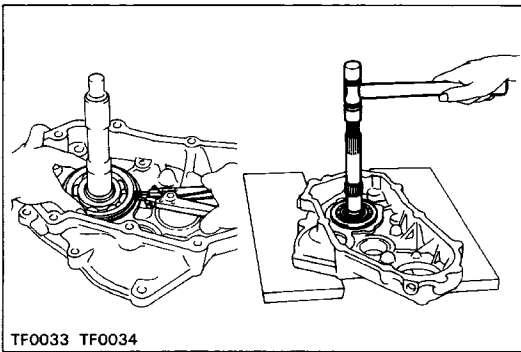

- (b) Using a snap ring pliers, remove the snap ring.
- (c) Using a plastic hammer, tap out the output shaft from the front case.

HINT: Place the front case on something soft such as wooden blocks.

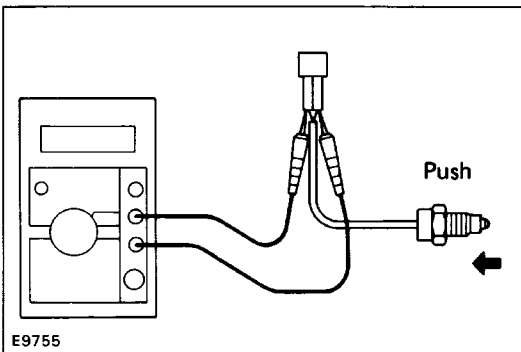

**24. INSPECTION OF TRANSFER INDICATOR SWITCH**

Check that there is continuity between terminals as shown.

Switch Position	Specified
Push	Continuity
Free	No continuity

If operation is not as specified, replace the switch.



# COMPONENT PARTS

## Input Gear

### COMPONENTS

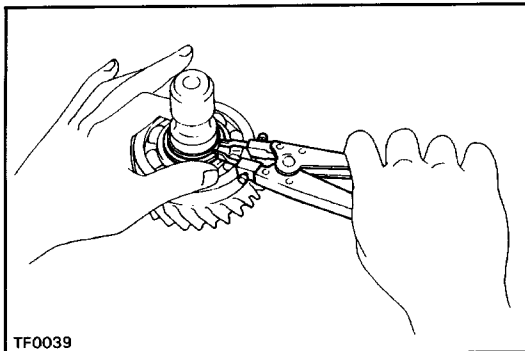
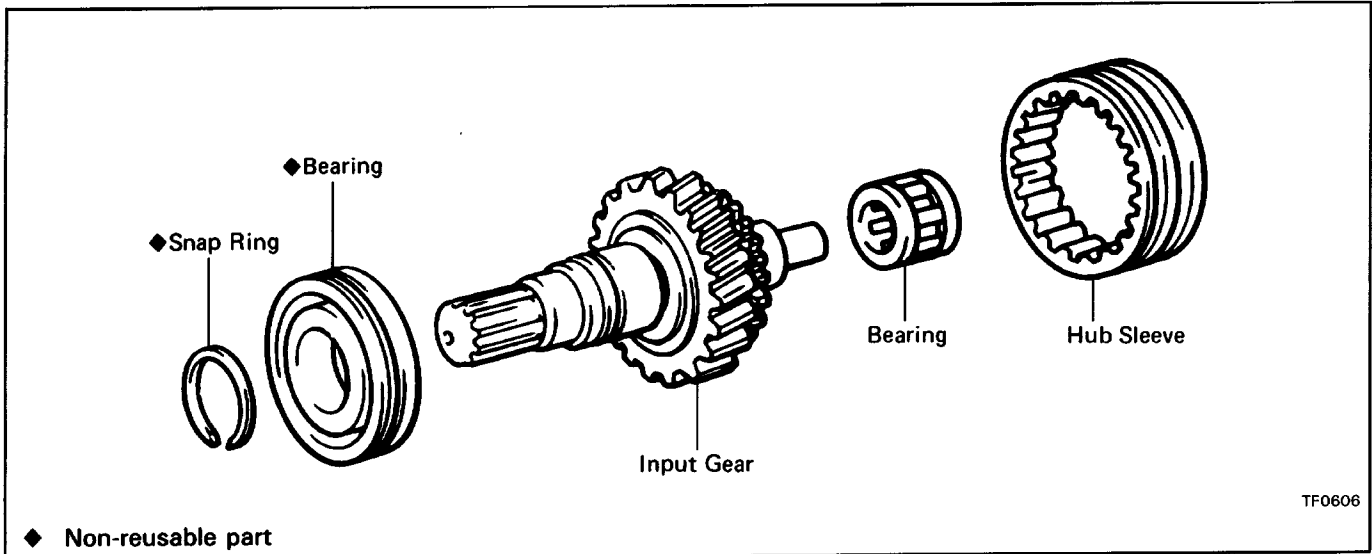

## REPLACEMENT OF BEARING

### IF NECESSARY, REPLACE INPUT GEAR BEARING

(a) Using snap ring pliers, remove the snap ring.

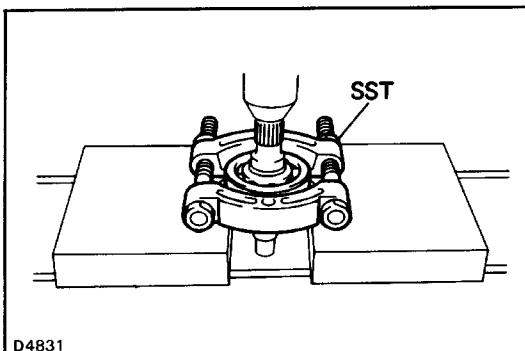

(b) Using SST and a press, remove the bearing.  
SST 09950-00020

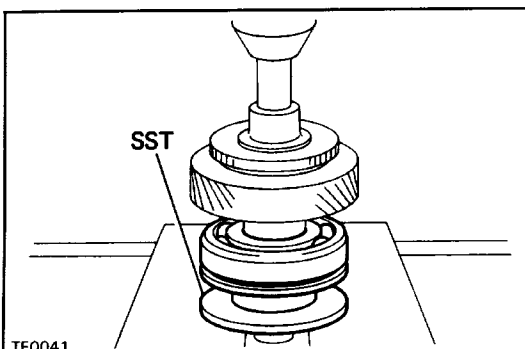

(c) Using SST, press in a new bearing.  
SST 09316-60010 (09316-00070)

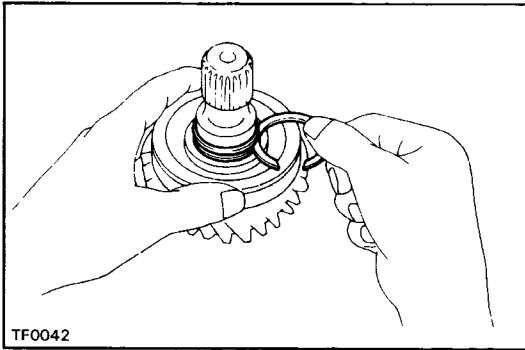

(d) Select a snap ring that will allow minimum axial play and install it on the shaft.

**Maximum play: 0.15 mm (0.0059 in.)**

Mark	Thickness	mm (in.)
1	2.05 – 2.10	(0.0807 – 0.0827)
3	2.15 – 2.20	(0.0846 – 0.0866)
5	2.25 – 2.30	(0.0886 – 0.0906)

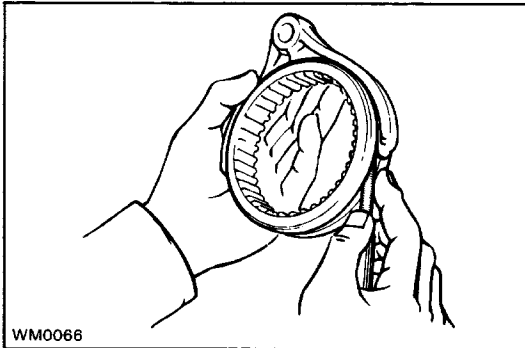

## INSPECTION OF HUB SLEEVE AND SHIFT FORK MEASURE

### CLEARANCE OF SHIFT FORK AND HUB SLEEVE

Using a feeler gauge, measure the clearance between the hub sleeve and shift fork.

**Maximum clearance: 1.0 mm (0.039 in.)**

If the clearance exceeds the limit, replace the shift fork or hub sleeve.

# Idler Gear COMPONENTS

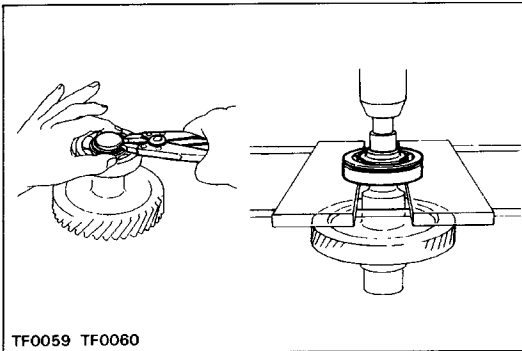
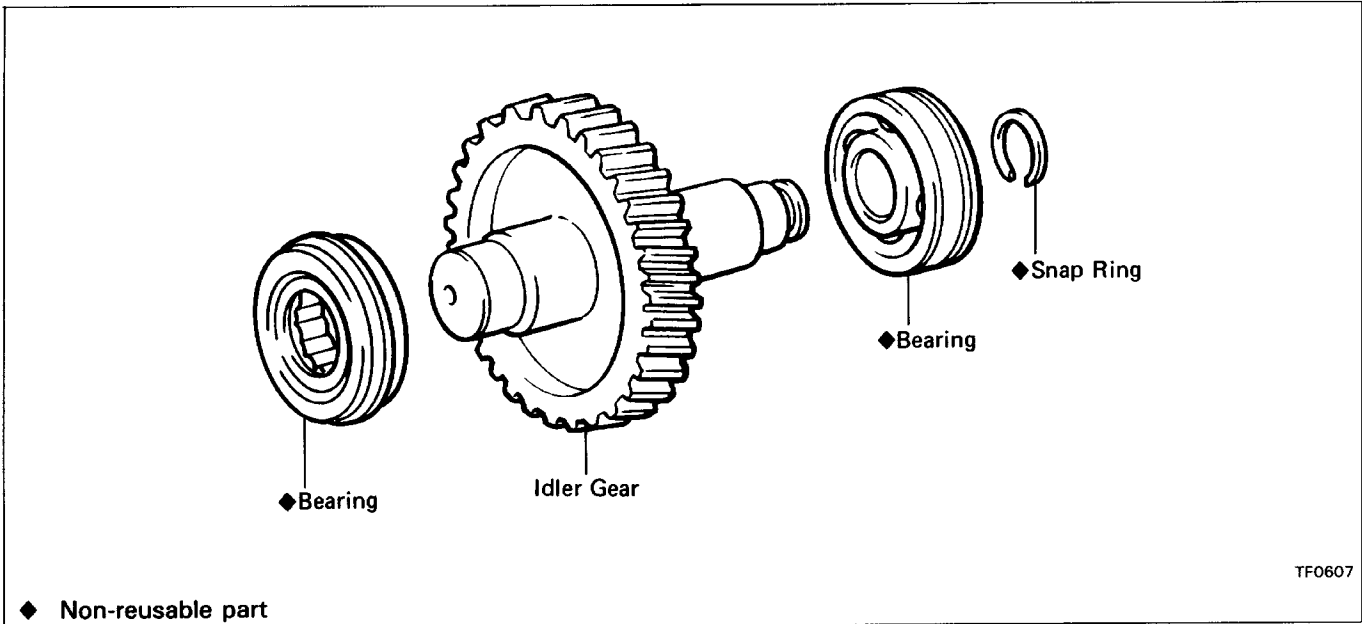

## REPLACEMENT OF BEARING

### 1. IF NECESSARY, REPLACE IDLER GEAR REAR BEARING

- (a) Using snap ring pliers, remove the snap ring.
- (b) Using a press and 19 mm socket wrench, remove the bearing.

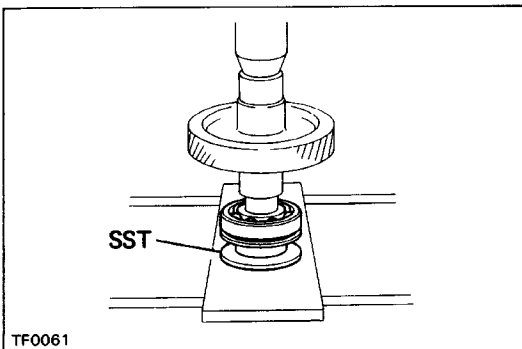

- (c) Using SST and a press, press in a new bearing.  
SST 09316-60010 (09316-00020)

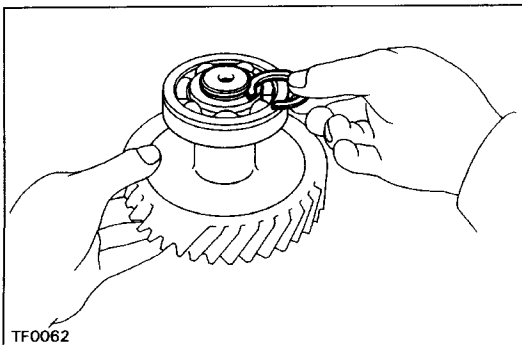

- (d) Select a snap ring that will allow minimum axial play and install it on the shaft.

**Maximum play: 0.15 mm (0.0059 in.)**

Mark	Thickness	mm(in.)
A	1.50 - 1.55	(0.0591 - 0.0610)
B	1.60 - 1.65	(0.0630 - 0.0650)

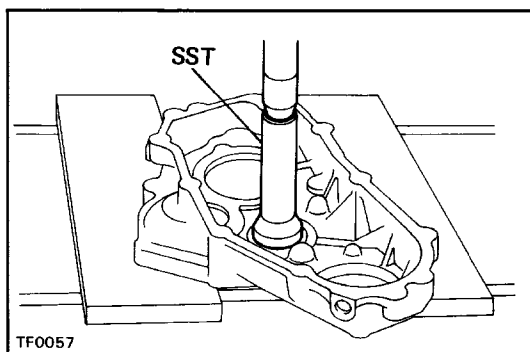

## 2. IF NECESSARY, REPLACE IDLER GEAR FRONT BEARING

(a) Using SST and a press, press out the bearing.  
SST 09310-35010

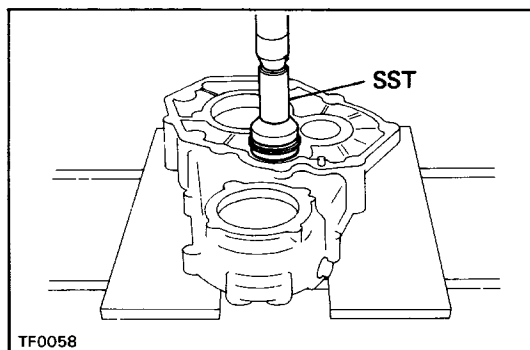

(b) Using SST and a press, press in a new bearing up to  
the position of the snap ring.  
SST 09310-35010

# Counter Gear COMPONENTS

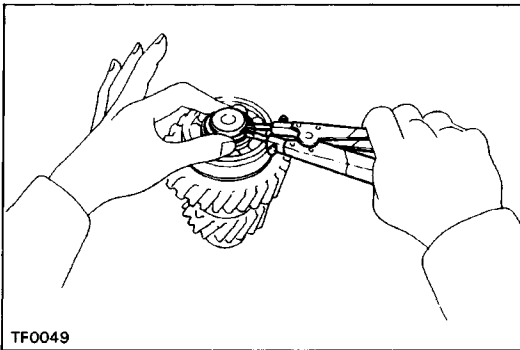
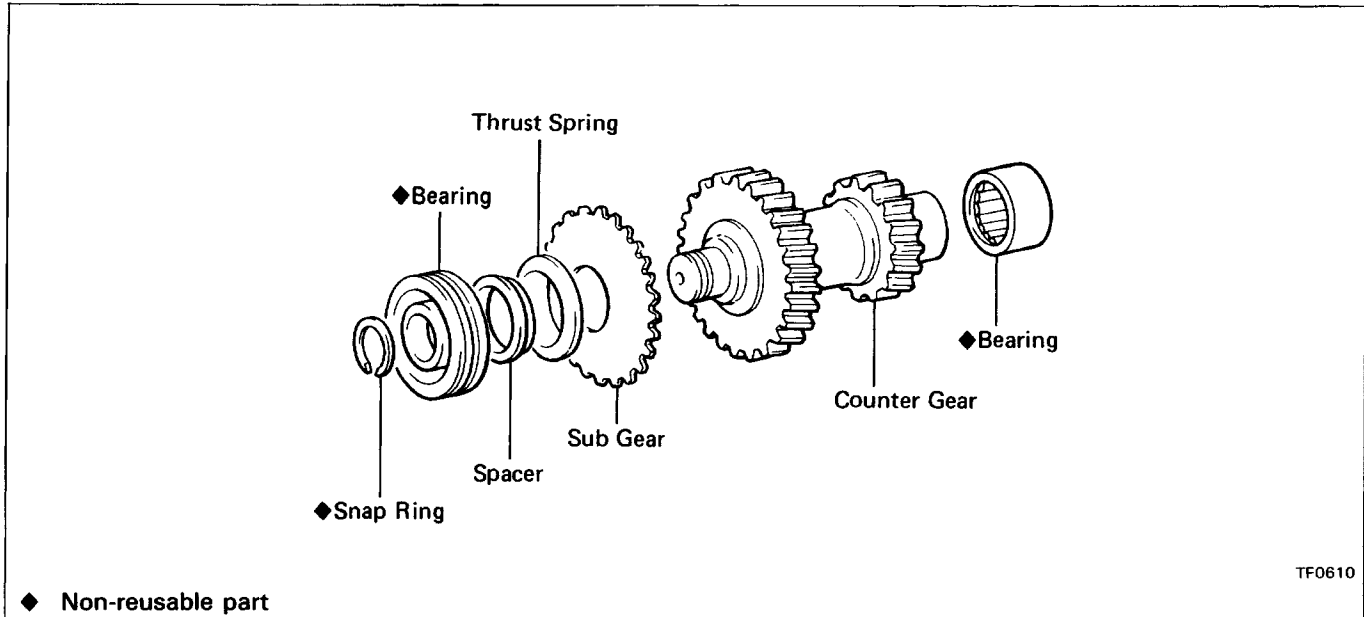

## REPLACEMENT OF BEARINGS

### 1. IF NECESSARY, REPLACE COUNTER GEAR FRONT BEARING AND SUB GEAR

(a) Using snap ring pliers, remove the snap ring.

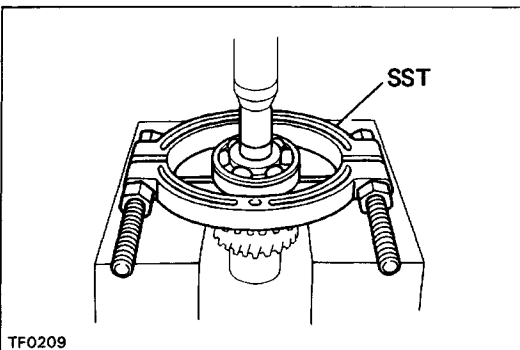

(b) Using SST and a press, remove the bearing.

SST 09950-00020

(c) Remove the spacer, thrust spring and sub gear.

(d) Install the sub gear, thrust spring and spacer on the counter gear.

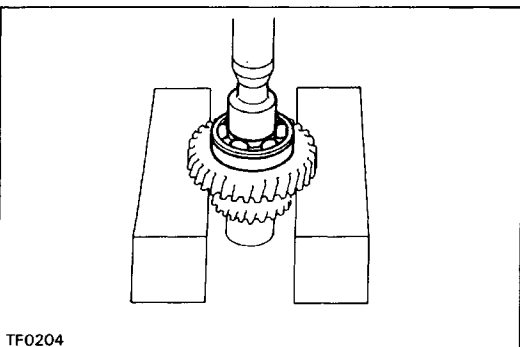

(e) Using a press and 32 mm socket wrench, install a new bearing.

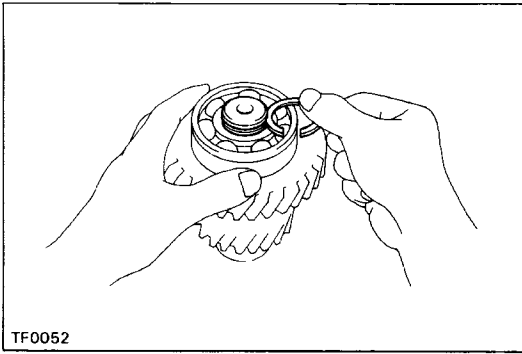

(f) Select a snap ring that will allow minimum axial play and install it on the shaft.

**Maximum play: 0.15 mm (0.0059 in. )**

Mark	Thickness	mm (in.)
1	2.10 – 2.15	(0.0827 – 0.0846)
3	2.20 – 2.25	(0.0866 – 0.0886)

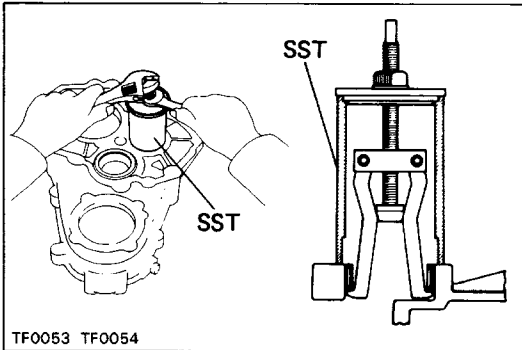

## 2. IF NECESSARY, REPLACE COUNTER GEAR REAR BEARING

(a) Using SST, remove the bearing.  
SST 09612-30012

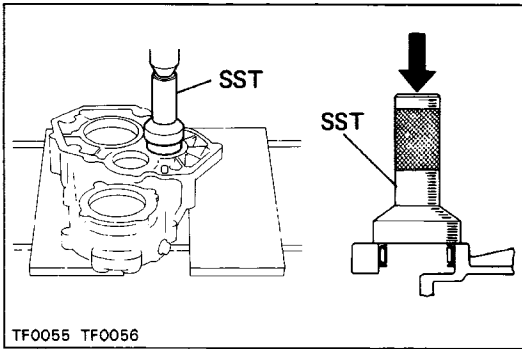

(b) Using SST and a press, press in a new bearing.  
SST 09310-35010

# Output Shaft COMPONENTS

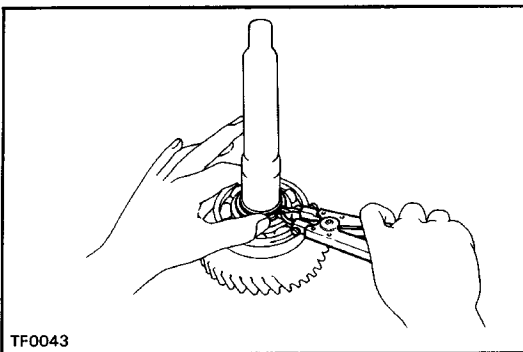
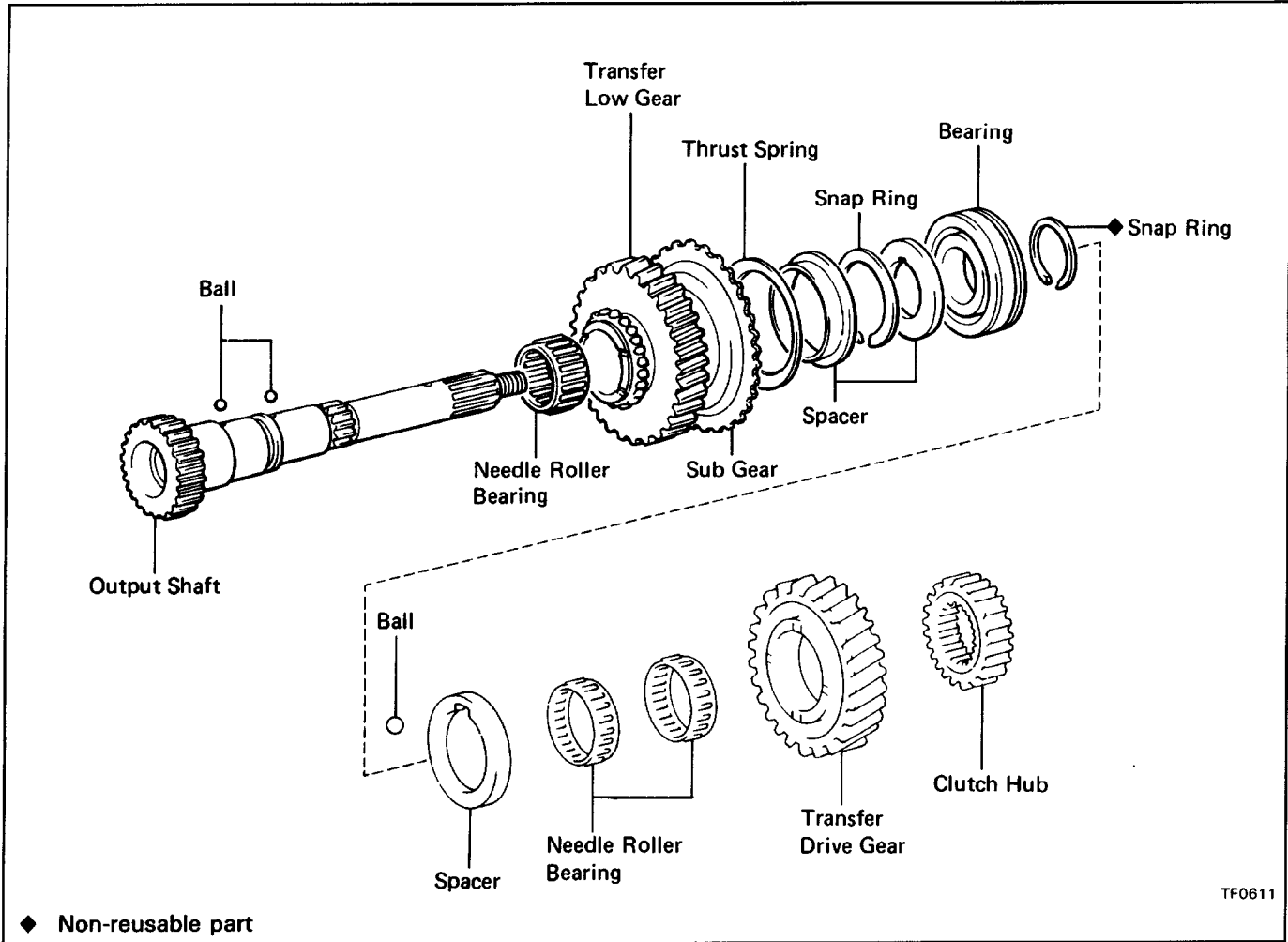

## DISASSEMBLY OF OUTPUT SHAFT ASSEMBLY

REMOVE OUTPUT SHAFT FRONT BEARING, LOW GEAR  
AND SUB GEAR

(a) Using snap ring pliers, remove the snap ring.

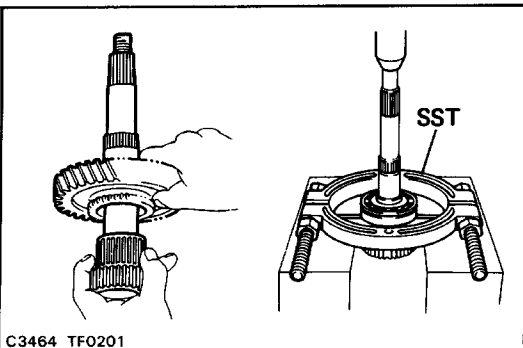

(b) Using SST and a press, remove the bearing, No. 1  
spacer and low gear.

SST 09950-00020

(c) Remove the steel ball and needle roller bearing.

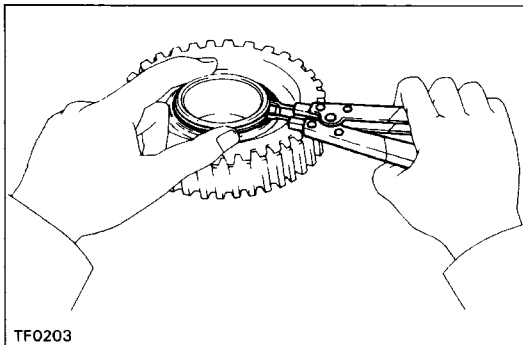

(d) Using snap ring pliers, remove the snap ring from the low gear.

(e) Remove the spacer, thrust spring and sub gear.

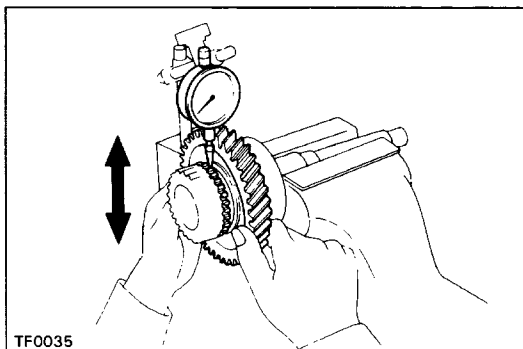

## INSPECTION OF OUTPUT SHAFT ASSEMBLY

### 1. CHECK OIL CLEARANCE AND THRUST CLEARANCE OF TRANSFER LOW GEAR

(a) Using a dial indicator, measure the oil clearance between the gear and shaft with the needle roller bearing installed.

**Standard clearance: 0.010 – 0.055 mm**  
(0.0004 – 0.0022 in.)

**Maximum clearance: 0.075 mm (0.0030 in.)**

If the clearance exceeds the limit, replace the gear, needle roller bearing or shaft.

(b) Using a dial indicator, measure the thrust clearance with the spacer and bearing installed.

HINT: Do not touch the shaft end of the dial indicator to the sub gear.

**Standard clearance: 0.10 – 0.25 mm**  
(0.0039 – 0.0098 in.)

**Maximum clearance: 0.30 mm (0.0118 in.)**

If the clearance exceeds the limit, replace the spacer.

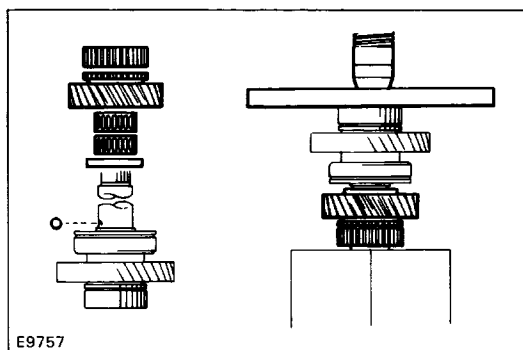
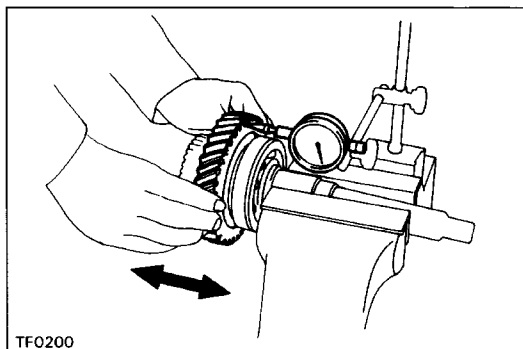

### 2. CHECK OIL CLEARANCE AND THRUST CLEARANCE OF TRANSFER DRIVE GEAR

(a) Using a press, install the ball, spacer, two needle roller bearings and transfer drive gear.

HINT: Do not loosen the ball.

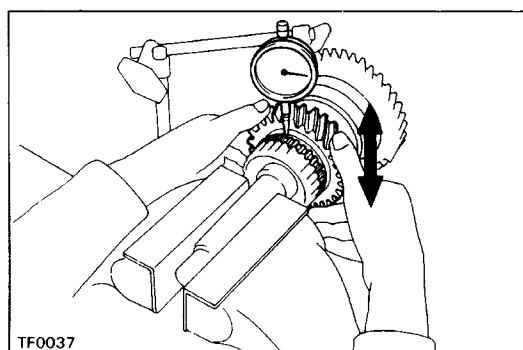

(b) Using a dial indicator, measure the oil clearance between the gear and shaft with the needle roller bearing installed.

**Standard clearance: 0.009 – 0.051 mm**  
(0.0004 – 0.0020 in.)

**Maximum clearance: 0.71 mm (0.028 in.)**

If the clearance exceeds the limit, replace the gear, needle roller bearing or shaft.



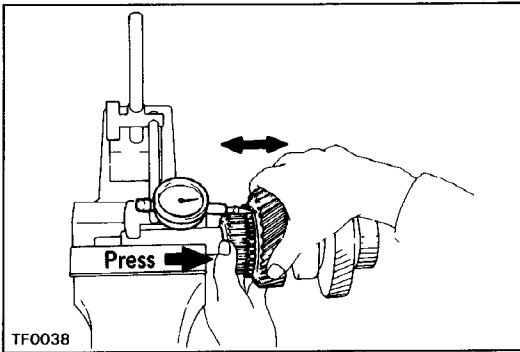

(c) Using a dial indicator, measure the thrust clearance with the clutch hub and spacer installed.

**Standard clearance: 0.09 – 0.27 mm  
(0.0035 – 0.0106 in.)**

**Maximum clearance: 0.32 mm (0.0126 in.)**

If the clearance exceeds the limit, replace the spacer.

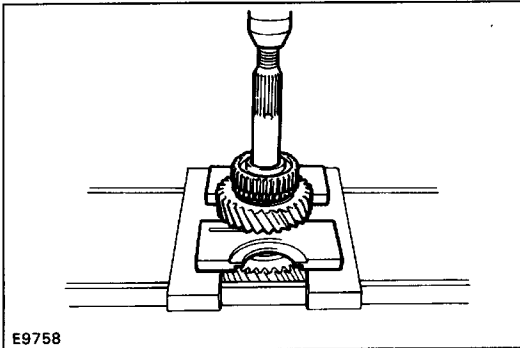

(d) Using a press, remove the ball, spacer, two needle roller bearings and transfer drive gear.

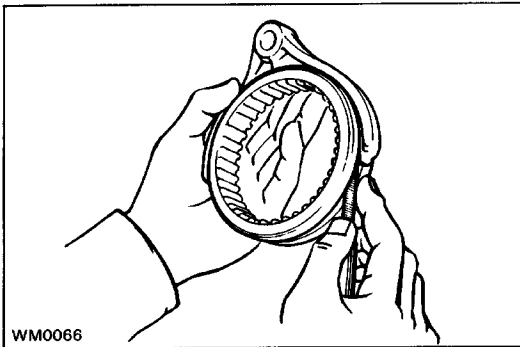

### 3. MEASURE CLEARANCE OF SHIFT FORKS AND HUB SLEEVES

Using a feeler gauge, measure the clearance between the hub sleeve and shift fork.

**Maximum clearance: 1.0 mm (0.039 in.)**

If the clearance exceeds the limit, replace the shift fork or hub sleeve.

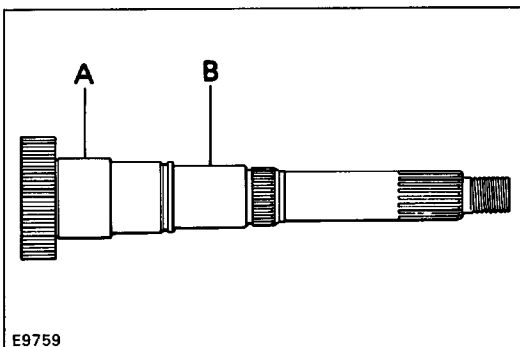

### 4. INSPECT OUTPUT SHAFT

(a) Using a micrometer, measure the outer diameter of the output shaft.

**Maximum outer diameter:**

**Part A 44.984 mm (1.7710 in.)**

**B 34.984 mm (1.3773 in.)**

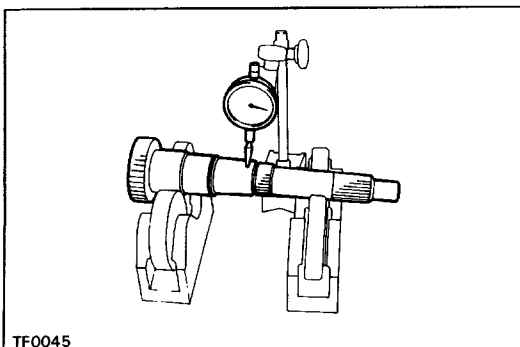

(b) Using a dial indicator, measure the shaft runout.

**Maximum runout: 0.03 mm (0.0012 in.)**

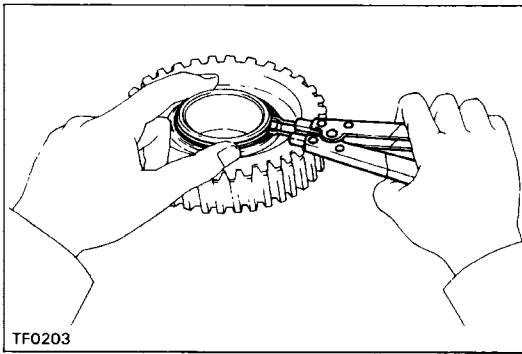

TF0203

## ASSEMBLY OF OUTPUT SHAFT

### INSTALL OUTPUT SHAFT FRONT BEARING LOW GEAR AND SUB GEAR

- (a) Install the sub gear, thrust spring and spacer.  
 (b) Using snap ring pliers, install the snap ring.

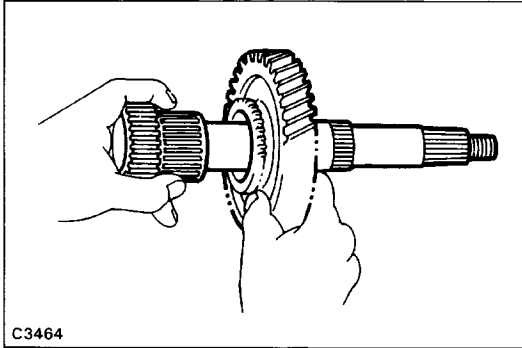

C3464

- (c) Apply MP grease to the needle roller bearing.  
 (d) Install the low gear with needle roller bearing to the output shaft.

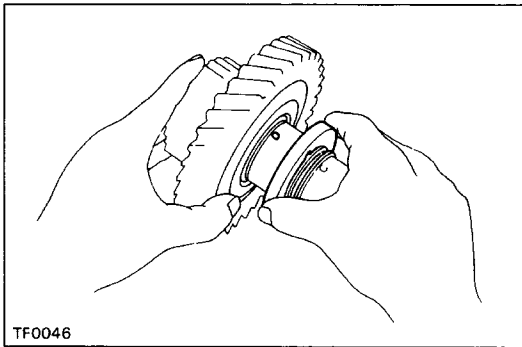

TF0046

- (e) Install the steel ball on the output shaft.  
 (f) Install the No. 1 spacer.

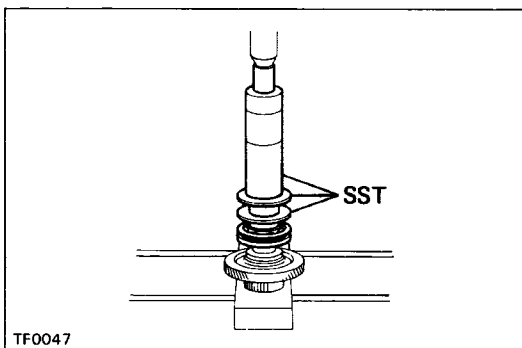

TF0047

- (g) Using SST and a press, install a new bearing.  
 SST 09316-60010 (09316-00010, 09316-00040, 09316-00050)

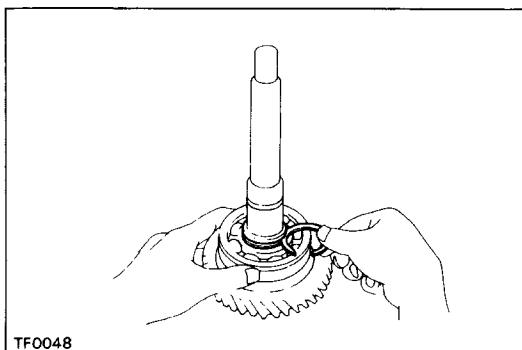

TF0048

- (h) Select a snap ring that will allow minimum axial play and install it on the shaft.

**Maximum play: 0.10 mm (0.0039 in.)**

Mark	Thickness	mm (in.)
0	2.40 – 2.45	(0.0945 – 0.0965)
1	2.45 – 2.50	(0.0965 – 0.0984)
2	2.50 – 2.55	(0.0984 – 0.1004)
3	2.55 – 2.60	(0.1004 – 0.1024)
4	2.60 – 2.65	(0.1024 – 0.1043)
5	2.65 – 2.70	(0.1043 – 0.1063)

## Front Drive Gear COMPONENTS

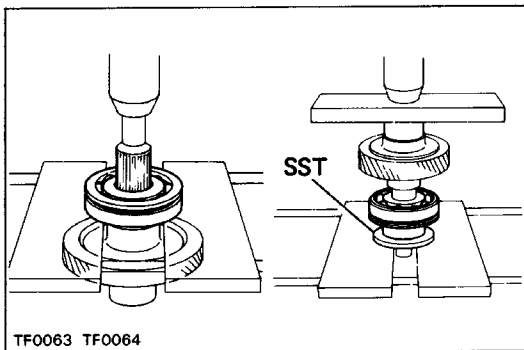
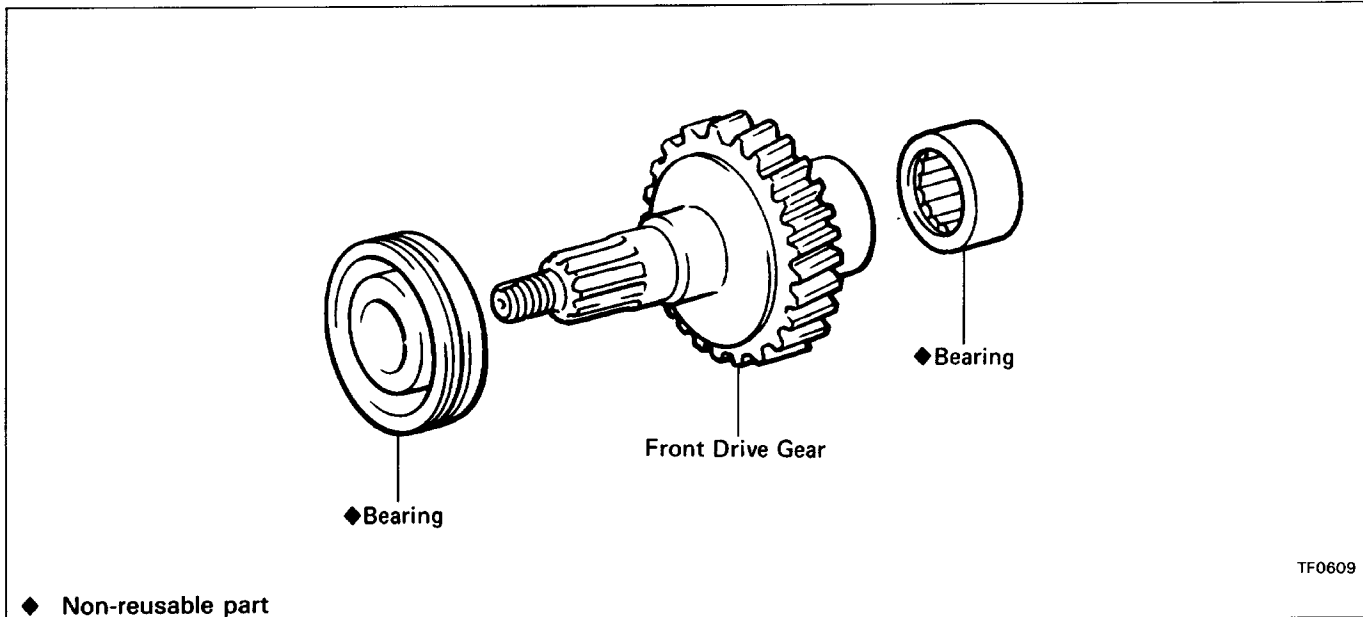

### REPLACEMENT OF BEARINGS

#### 1. IF NECESSARY, REPLACE FRONT DRIVE GEAR FRONT BEARING

- (a) Press out the bearing.
- (b) Using SST and a press, press in a new bearing.  
SST 09316-60010 (09316-00020)

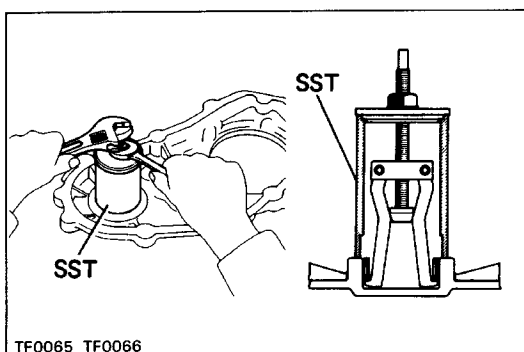

#### 2. IF NECESSARY, REPLACE FRONT DRIVE GEAR REAR BEARING

- (a) Using SST, remove the bearing.  
SST 09612-30012

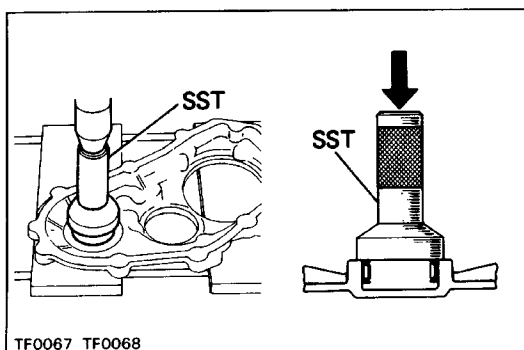

- (b) Using SST and a press, press in a new bearing.  
SST 09310-3 5010

# Oil Seals

## COMPONENTS

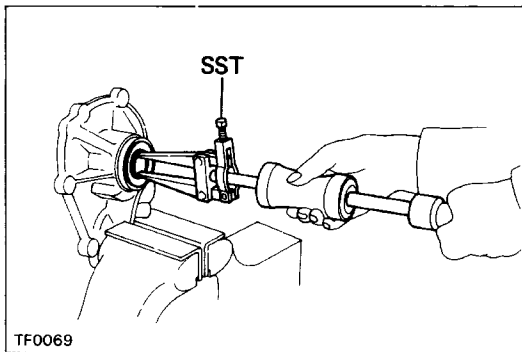
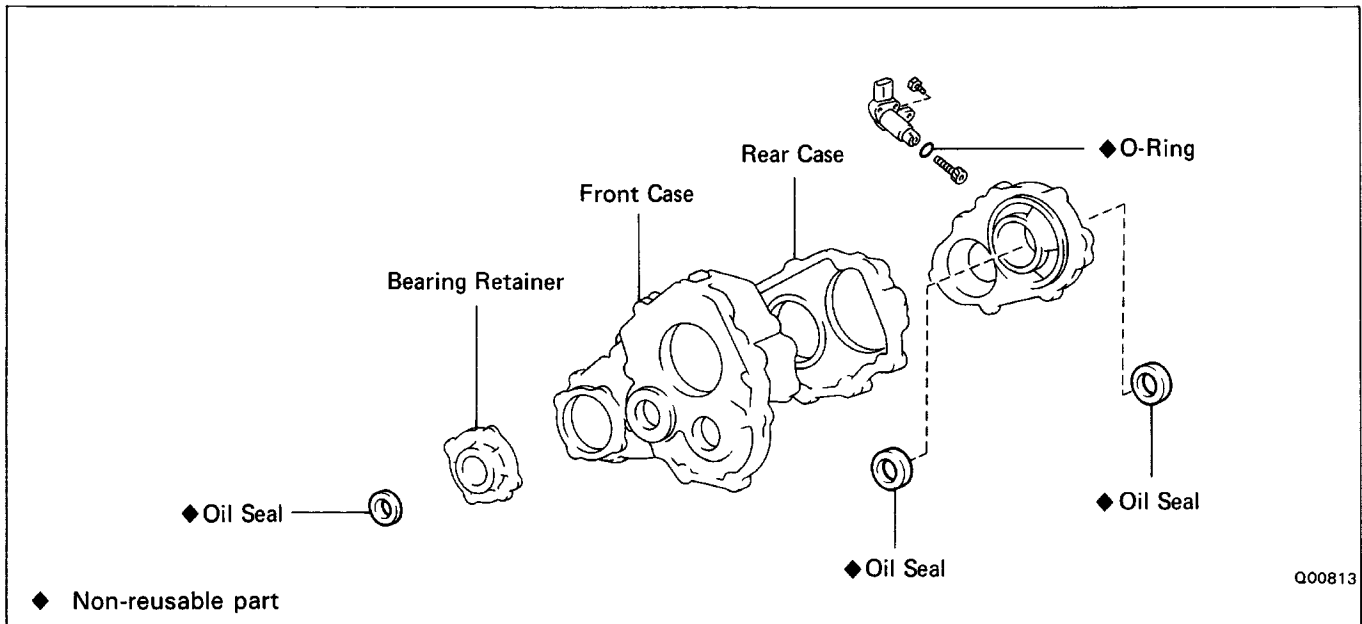

## REPLACEMENT OF OIL SEALS

### 1. IF NECESSARY, REPLACE EXTENSION HOUSING OIL SEAL

(a) Using SST, remove the two oil seals.  
SST 09308-00010

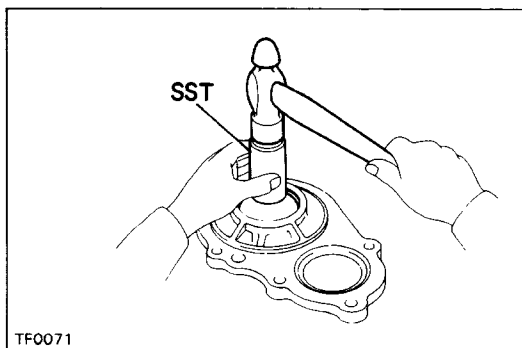

(b) Using SST and a hammer, drive in a new oil seal.  
SST 09310-35010

HINT: When assembling a new oil seal for the oil pump screw, position the flat surface upward.

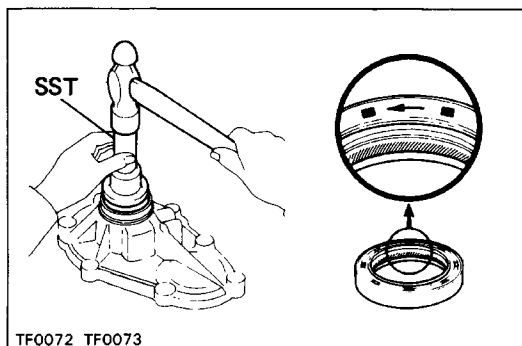

(c) Using SST and a hammer, drive in a new oil seal.  
SST 09325-20010

HINT: Take note of the groove direction and be careful not to interchange this seal with the front drive gear oil seal. This oil seal has one arrow mark pointing counter-clockwise to distinguish it from the front drive gear oil seal.

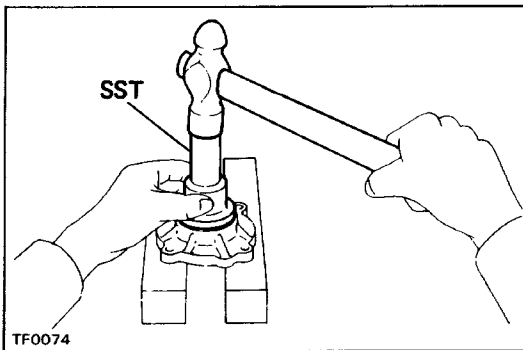

## 2. IF NECESSARY, REPLACE FRONT DRIVE GEAR OIL SEAL

(a) Using SST and a hammer, drive out the oil seal and dust cover.

SST 09325-20010

HINT: Place the bearing retainer on something soft such as wooden blocks.

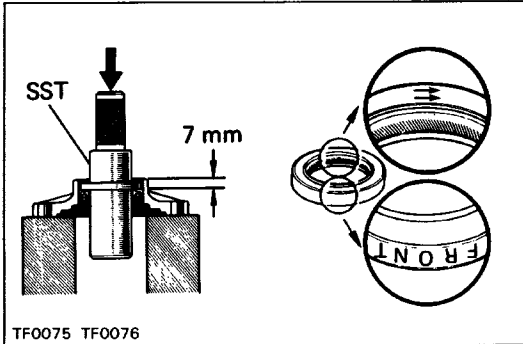

(b) Using SST and a hammer, drive in a new oil seal to a depth of 7 mm (0.28 in.) from the end.

SST 09325-20010

HINT: Take note of the groove direction and be careful not to interchange this seal with the output shaft oil seal. This oil seal has two arrow marks pointing clockwise and the word FRONT to distinguish it from the output shaft.

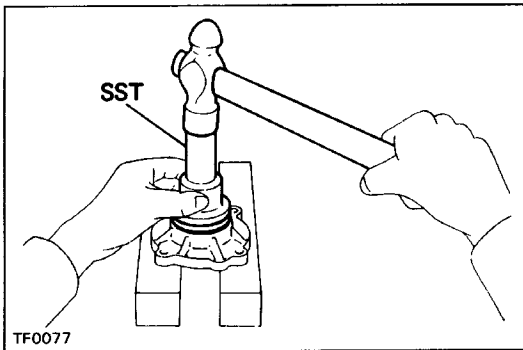

(c) Using SST and a hammer, drive in a new dust cover.

SST 09325-20010

## ASSEMBLY OF TRANSFER

(See page [TF-7](#))

### 1. INSTALL OUTPUT SHAFT TO FRONT CASE

(a) Using a plastic hammer, install the output shaft to the front case.

HINT: Place the front case on something soft such as wooden blocks.

(b) Using snap ring pliers, install the snap ring.

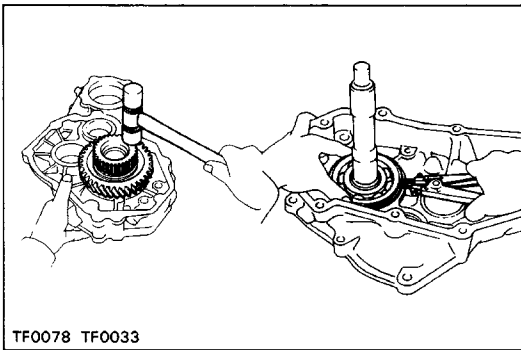

### 2. INSTALL BEARING RETAINER TO FRONT CASE

(a) Install the bearing retainer with four bolts.

(b) Torque the bolts.

**Torque: 18 N-m (185 kgf-cm, 13 ft-lbf)**

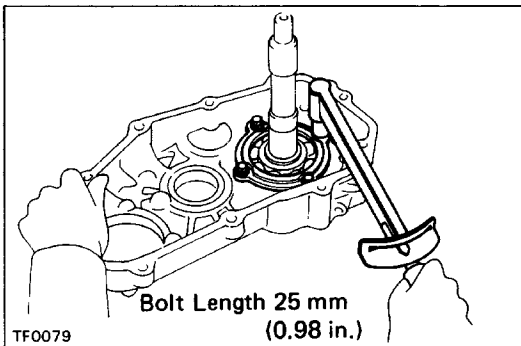

### 3. INSTALL INPUT GEAR AND COUNTER GEAR TO REDUCTION GEAR CASE

(a) Using a plastic hammer, install the input gear and counter gear to the reduction gear case.

HINT: Place the reduction gear case on something soft such as wooden blocks.

(b) Using snap ring pliers, install the snap rings.

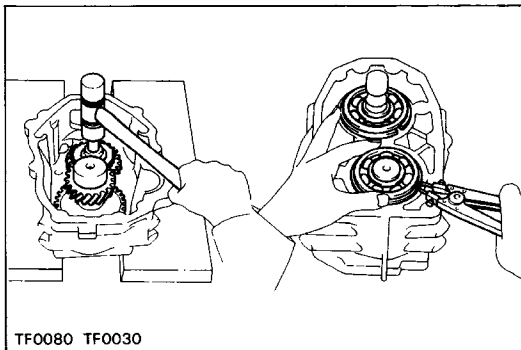

### 4. INSTALL ROLLER BEARING ON INPUT SHAFT

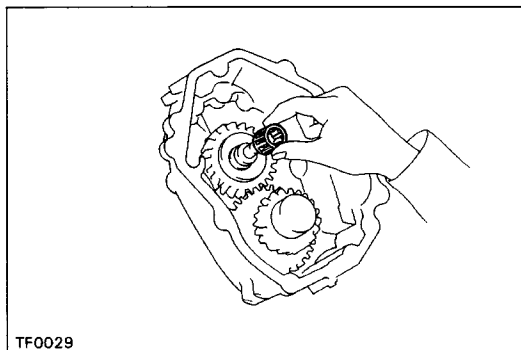

### 5. INSTALL NO.2 HUB SLEEVE AND NO.2 SHIFT FORK ON INPUT SHAFT

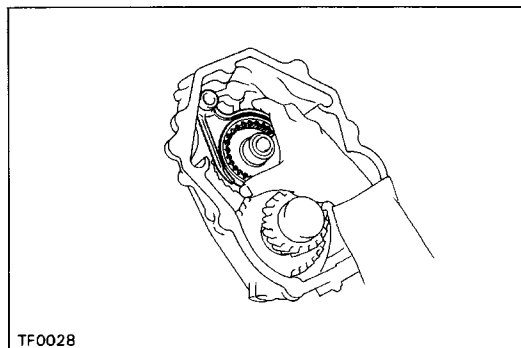

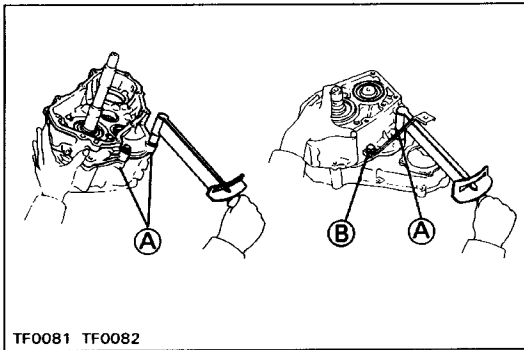

## 6. INSTALL REDUCTION GEAR CASE WITH NEW GASKET TO FRONT CASE

- Place a new gasket on the front case.
- Install the reduction gear case together with the input gear and counter gear.
- Install and torque the bolts as shown in the figure.

### Torque:

- (A) Bolt length 47 mm (1.85 in.)  
39 N-m (400 kgf-cm, 29 ft-lbf)
- (B) Bolt length 49 mm (1.93 in.)  
39 N-m (400 kgf-cm, 29 ft-lbf)

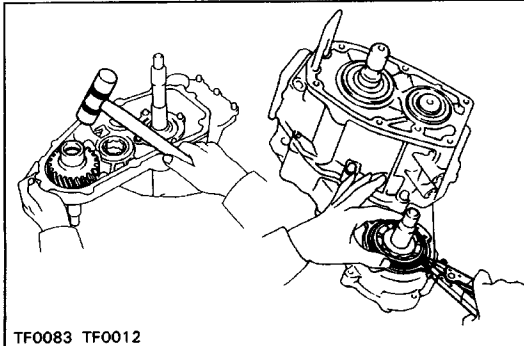

## 7. INSTALL FRONT DRIVE GEAR

- Using a plastic hammer, install the front drive gear.
- Using snap ring pliers, install the snap ring.

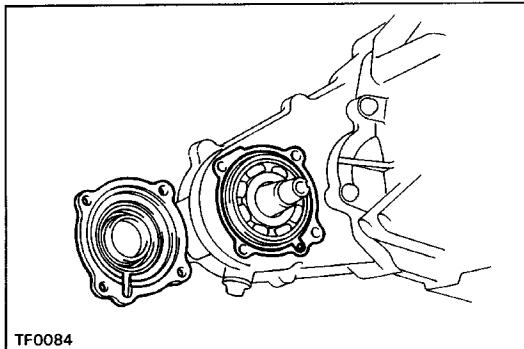

## 8. INSTALL BEARING RETAINER WITH NEW GASKET

- Place a new gasket on the front case.
- Apply MP grease to the oil seal.
- Install the bearing retainer.

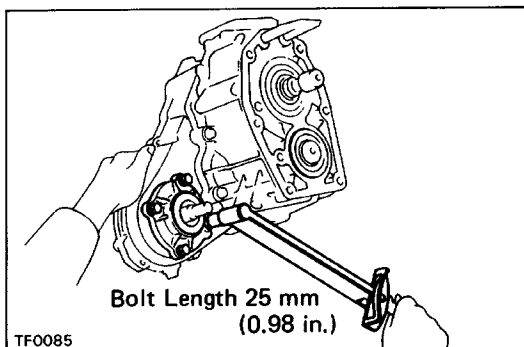

- Install and torque the bolts.

**Torque: 18 N-m (185 kgf-cm, 13 ft-lbf)**

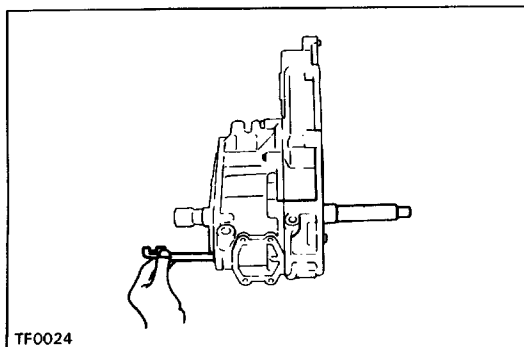

## 9. INSTALL HIGH AND LOW SHIFT FORK SHAFT

- Install the high and low shift fork shaft to the No.2 shift fork.

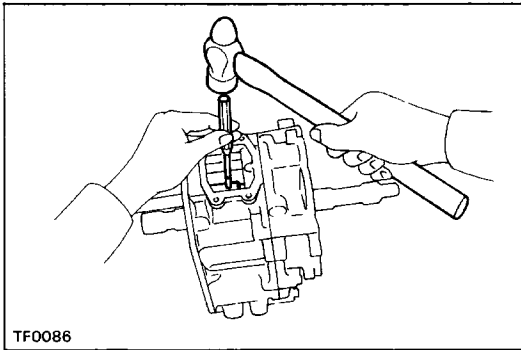

(b) Align the slotted spring hole in the fork with the hole in the shaft.

(c) Using a pin punch and hammer, drive in the slotted spring pin.

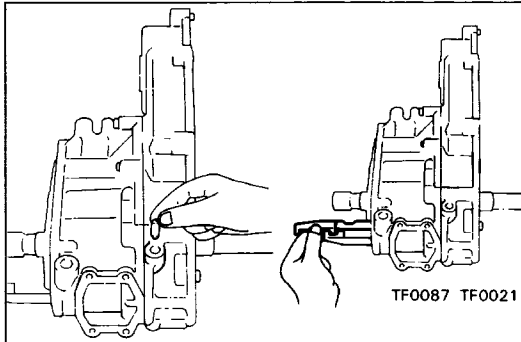

## 10. INSTALL INTERLOCK PIN AND FRONT DRIVE SHIFT FORK SHAFT

(a) Install the interlock pin.

(b) Install the front drive shift fork shaft with the two grooves facing outward.

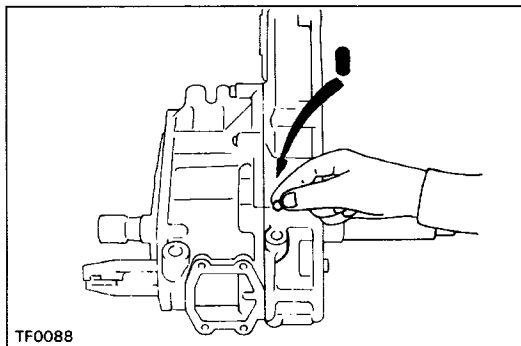

## 11. INSTALL TWO BALLS, SPRINGS AND PLUGS

(a) Install the ball and spring.

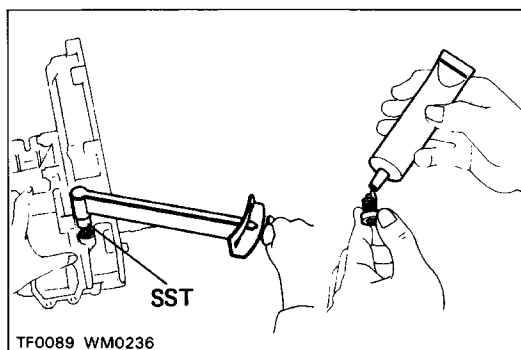

(b) Apply liquid sealer to the plug threads.

**Sealant: Part No. 08833-00080, THREE BOND 1344, LOCTITE 242 or equivalent**

(c) Using SST, install and torque the plug.  
SST 09313-30021

**Torque: 12 N-m (120 kgf-cm, 9 ft-lbf)**

(d) Install the ball, spring and plug to the opposite side.

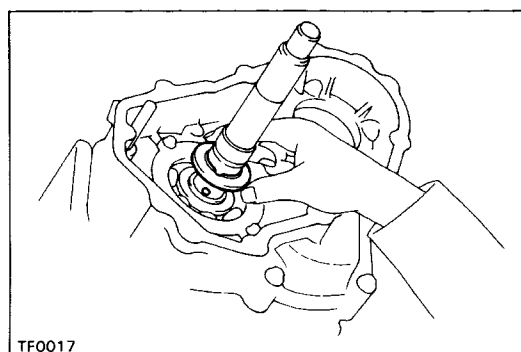

## 12. INSTALL LOCKING BALL AND NO.2 SPACER



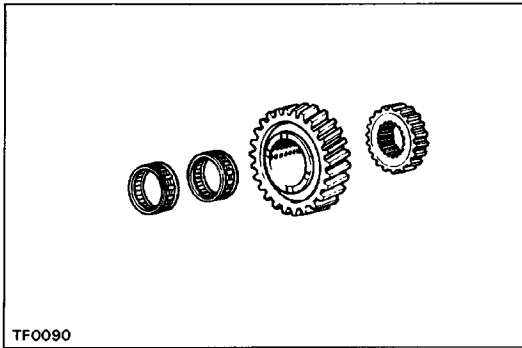

TF0090

### 13. INSTALL NEEDLE ROLLER BEARINGS, TRANSFER LOWER GEAR AND CLUTCH HUB

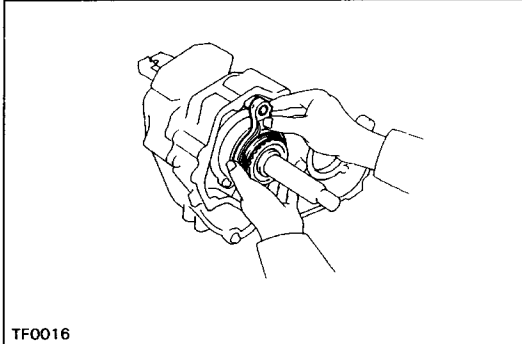

TF0016

### 14. INSTALL NO. 1 SHIFT FORK AND HUB SLEEVE

(a) Install the No.1 shift fork together with the hub sleeve to the front drive shift fork shaft.

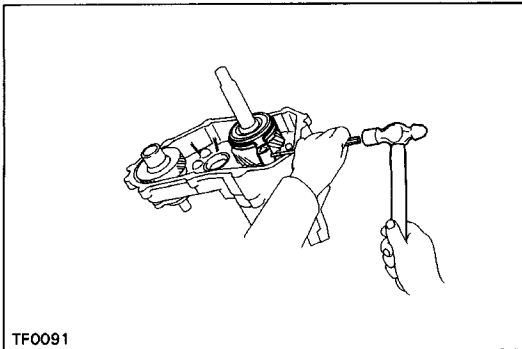

TF0091

(b) Align the slotted pin hole in the fork with the hole in the shaft.

(c) Using a pin punch and hammer, install the slotted spring pin.

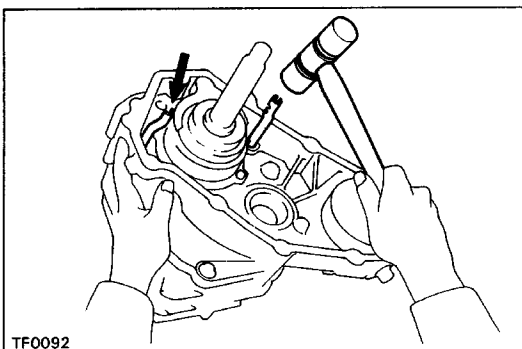

TF0092

### 15. INSTALL OIL PIPES

Install the two oil pipes with the cutout side positioned upward.

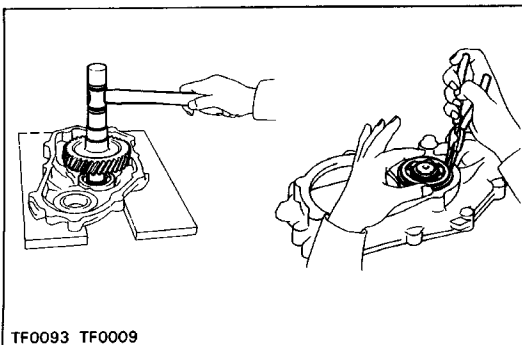

TF0093 TF0009

### 16. INSTALL IDLER GEAR TO REAR CASE

(a) Using a plastic hammer, install the idler gear to the rear case.

HINT: Place the rear case on something soft such as wooden blocks.

(b) Using snap ring pliers, install the snap ring.

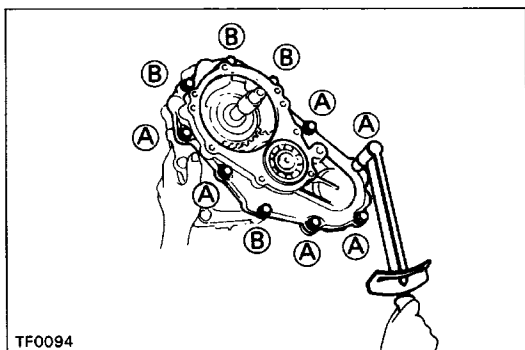
**17. INSTALL REAR CASE WITH NEW GASKET**

- (a) Place a new gasket on the front case.
- (b) Install the rear case together with the idler gear.
- (c) Install and torque the bolts as shown in the figure.

**Torque:**

(A) Bolt length 47 mm (1.85 in.)

Ⓑ 39 N-m (400 kgf-cm, 29 ft-lbf)

(B) Bolt length 112 mm (4.41 in.)

39 N-m (400 kgf-cm, 29 ft-lbf)

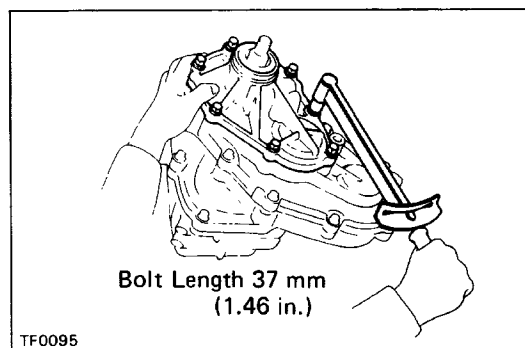
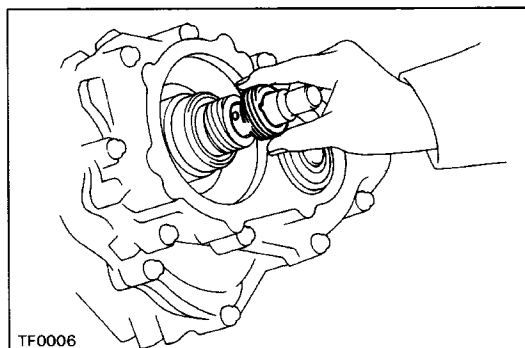
**18. INSTALL BEARING, OIL PUMP SCREW, LOCKING BALL AND SPEEDOMETER DRIVE GEAR****19. INSTALL EXTENSION HOUSING WITH NEW GASKET**

- (a) Place a new gasket to the rear case.
  - (b) Apply MP grease to the two oil seals.
  - (c) Install the extension housing with seven bolts.
- Torque the bolts.

**Torque: 39 N-m (400 kgf-cm, 29 ft-lbf)**

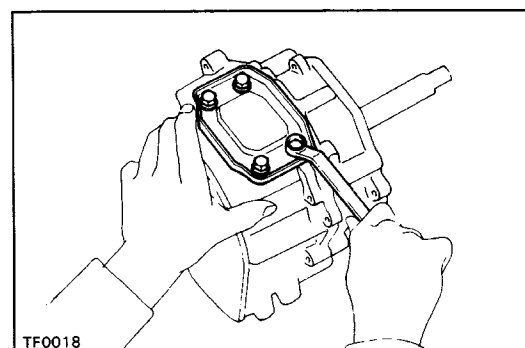
**20. INSTALL TRANSFER CASE COVER WITH NEW GASKET**

- (a) Place a new gasket to the transfer case cover.
- (b) Install and torque the four bolts.

**Torque: 8.8 N-m (90 kgf-cm, 78 in.lbf)**

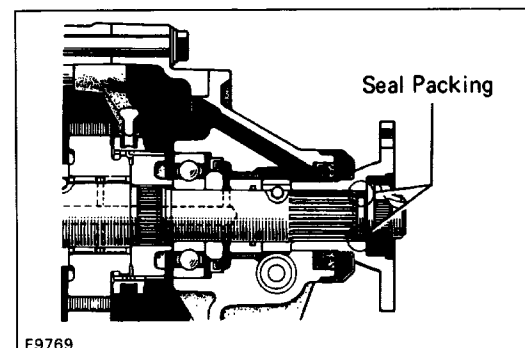
**21. INSTALL REAR COMPANION FLANGE**

- (a) Install the companion flange to the output shaft.
- (b) Apply seal packing to the output shaft and companion flange as shown.

**Seal packing: Part No. 08826-00090 THREE BOND  
1281 or equivalent**

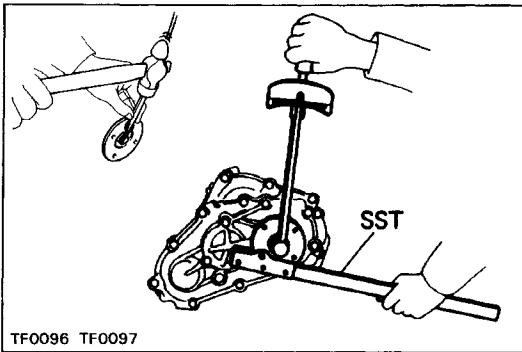

(c) Using SST to hold the flange, install the washer and nut. Torque the nut.

SST 09330-00021

**Torque: 123 N-m (1,250 kgf-cm, 90 ft-lbf)**

(d) Stake the nut.

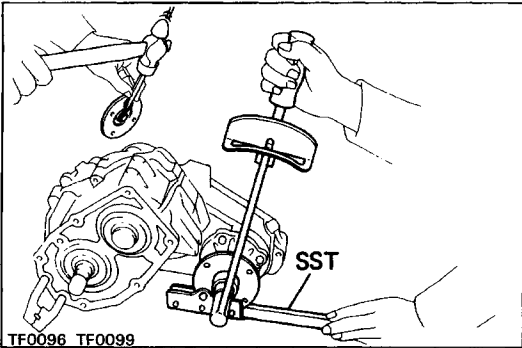

## 22. INSTALL FRONT COMPANION FLANGE

(a) Install the companion flange to the front drive gear.

(b) Using SST to hold the flange, install the washer and nut. Torque the nut.

SST 09330-00021

**Torque: 123 N-m (1,250 kgf-cm, 90 ft-lbf)**

(c) Stake the nut.

## 23. INSTALL TRANSFER INDICATOR SWITCH WITH WASHER

**Torque: 34 N-m (350 kgf-cm, 25 ft-lbf)**

## 24. INSTALL NO. 1 SPEED SENSOR

(a) Install the No. 1 speed sensor.

(b) Install and torque the bolt.

**Torque: 11 N-m (115 kgf-cm, 8 ft-lbf)**

# (VF1A TYPE TRANSFER) COMPONENTS

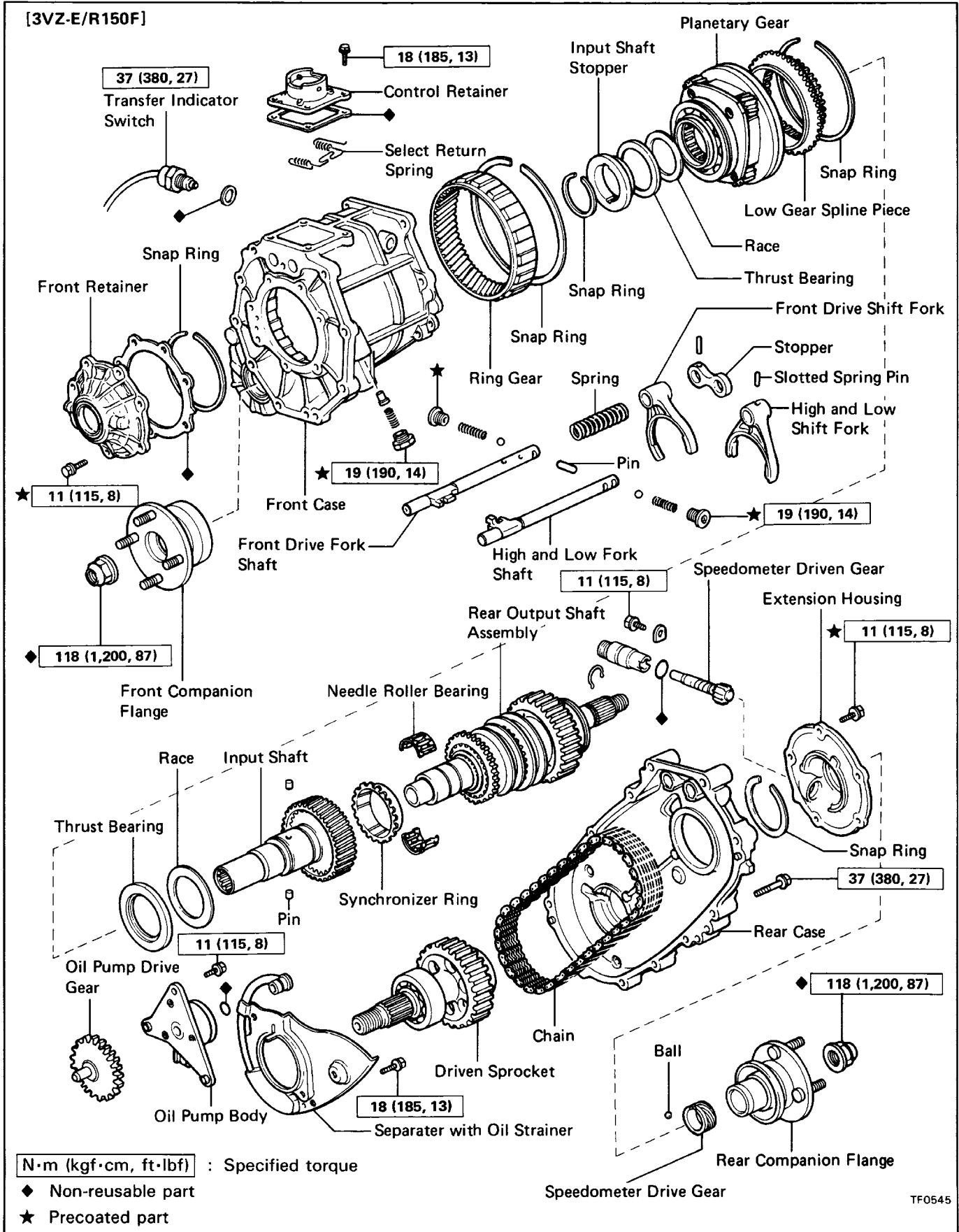

# COMPONENTS (Cont'd)

[22R-E/G58, A340F]

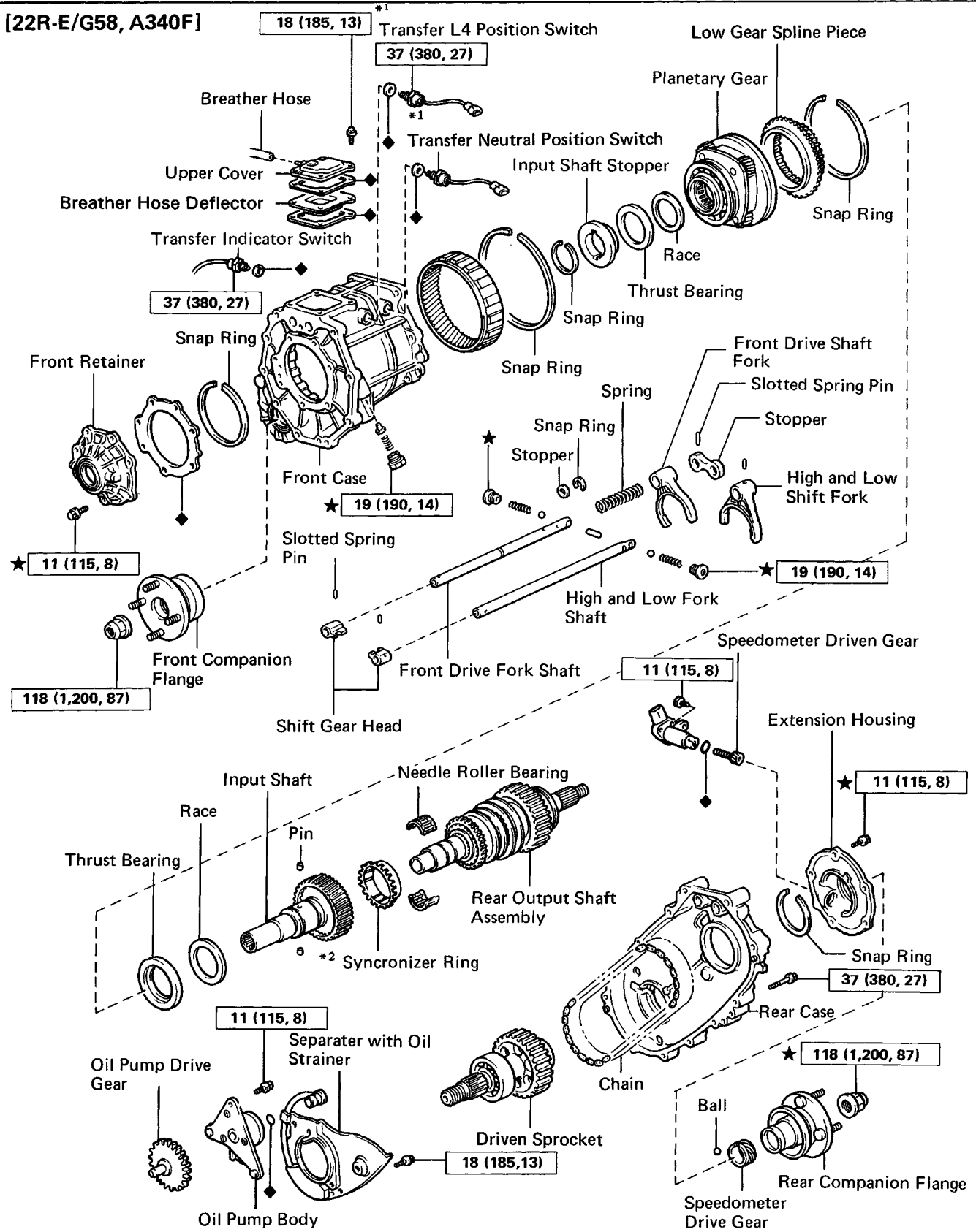

**N·m (kgf·cm, ft·lbf)** : Specified torque

- ◆ Non-reusable part
- ★ Precoated part

- \*1 A340F Automatic Transmission
- \*2 G58 Manual Transmission

## DISASSEMBLY OF TRANSFER

(See pages [TF-32](#) and [33](#))

1. REMOVE SPEEDOMETER DRIVEN GEAR
2. REMOVE TRANSFER INDICATOR SWITCH
3. (22R-E/A340F)  
REMOVE TRANSFER L4 POSITION SWITCH

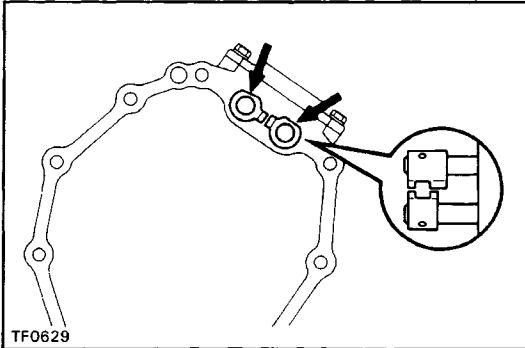

4. (22R-E/G58, A340F)

### REMOVE SHIFT GEAR HEAD NO. 1 AND NO.2

- (a) Using a pin punch and hammer, drive out the two slotted spring pins.
- (b) Remove two shift gear heads.

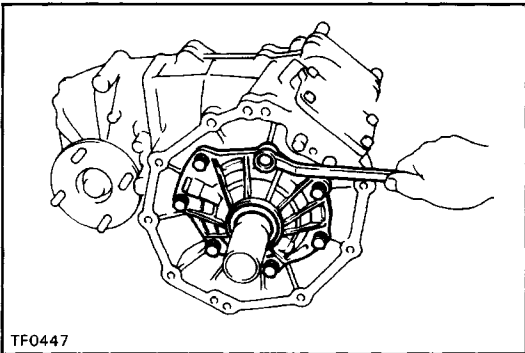

5. REMOVE FRONT RETAINER

Remove the seven bolts and the front retainer.

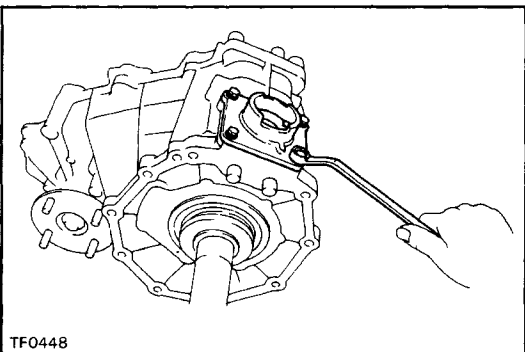

- 6.-1 (3VZ-E/R150F)

### REMOVE CONTROL RETAINER

- (a) Remove the four bolts and the control retainer.

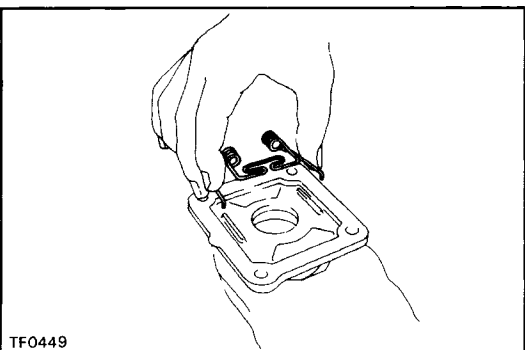

- (b) Remove the select return spring from the retainer.

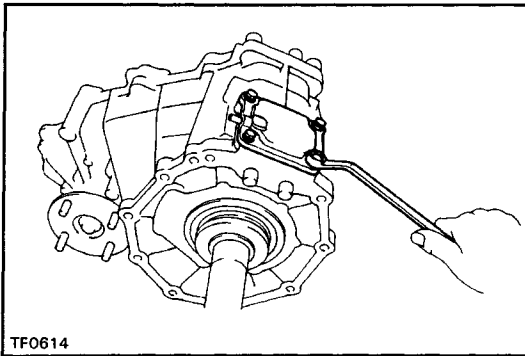
**6.-2 (22R-E/G58, A340F)****REMOVE UPPER COVER AND OIL DEFLECTOR**

Remove the four bolts and the upper cover and oil deflector.

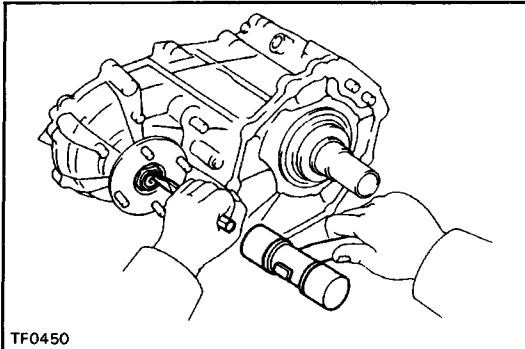
**7. REMOVE FRONT COMPANION FLANGE**

(a) Using a hammer and chisel, loosen the staked part of the nut.

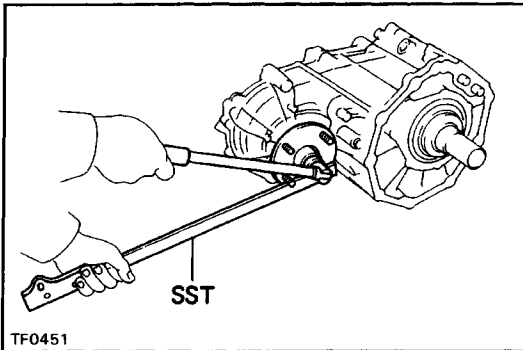

(b) Using SST to hold the flange, remove the companion flange lock nut.

SST 09330-00021 –

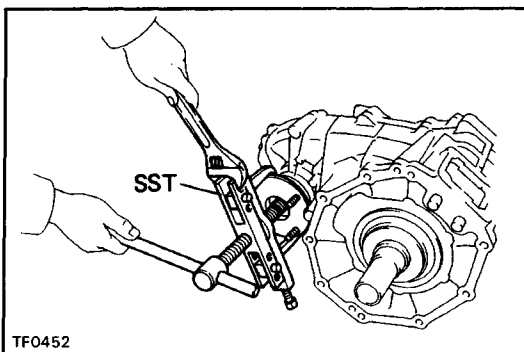

(c) Using SST, remove the companion flange.

SST 09950-20017

**8. REMOVE REAR COMPANION FLANGE**

Remove the rear companion flange in the same way as the front companion flange.

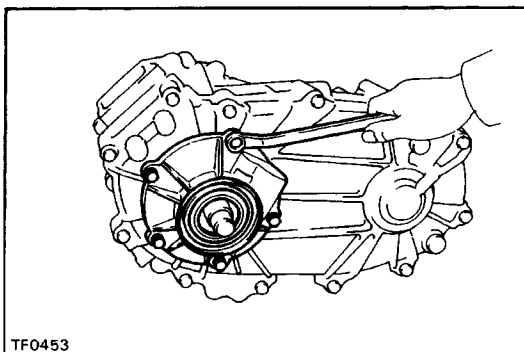
**9. REMOVE EXTENSION HOUSING**

(a) Remove the five bolts.

(b) Using a plastic hammer, tap the extension housing and remove it.

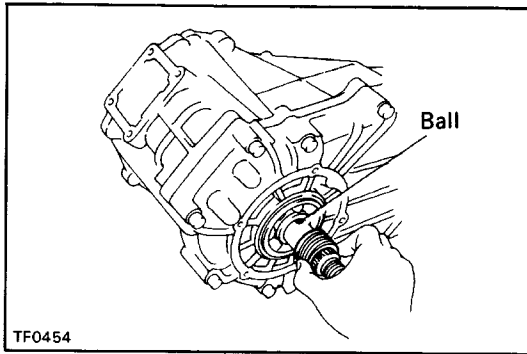
**10. REMOVE SPEEDOMETER DRIVE GEAR**

- (a) Remove the speedometer drive gear.
- (b) Using a magnetic finger, remove the ball from the rear output shaft.

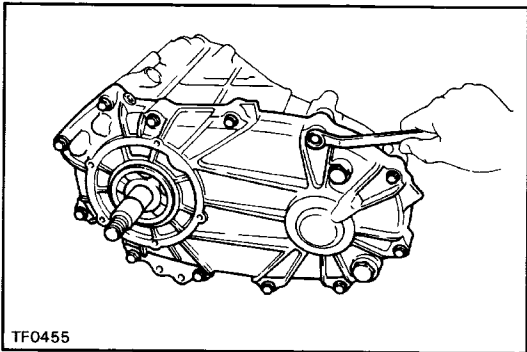
**11. SEPARATE FRONT CASE AND REAR CASE**

- (a) Remove the twelve bolts.

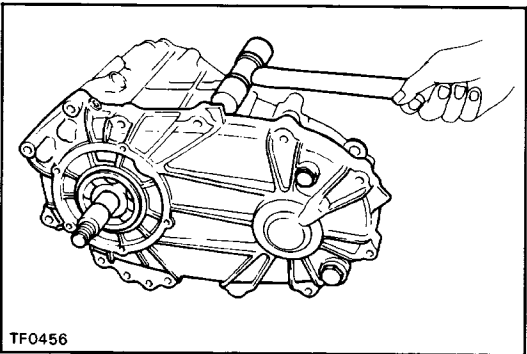

- (b) Using a plastic hammer, tap the rear case and separate the front case and rear case.

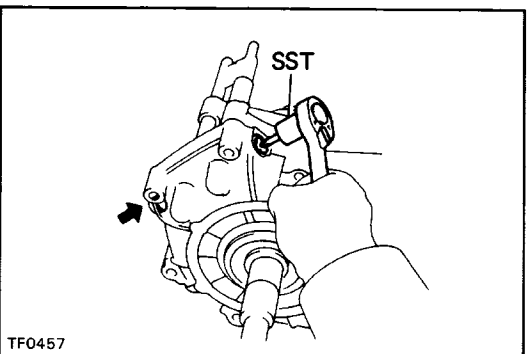
**12. REMOVE STRAIGHT SCREW PLUGS, SPRINGS AND LOCKING BALLS**

- (a) Using SST, remove the two screws.  
SST 09313-30021

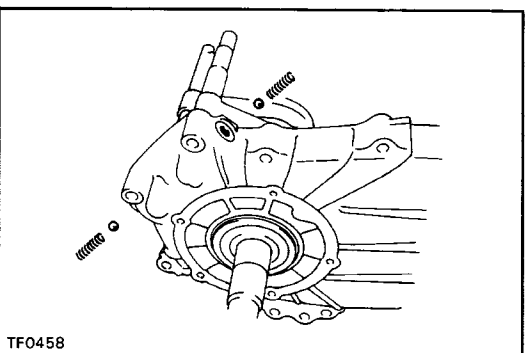

- (b) Using a magnetic finger, remove the spring and ball from the both holes.



3VZ-E/R150F

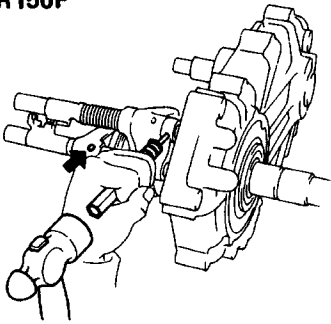

TF0459

### 13. REMOVE FRONT DRIVE FORK SHAFT, FORK AND SPRING

(a) Using a pin punch and hammer, drive out the two slotted spring pins.

HINT: When the pin is removed from the front drive fork shaft, the shaft will spring loose if the pin punch is removed, so keep the pin punch inserted in the shaft hole.

22R-E/G58, A340F

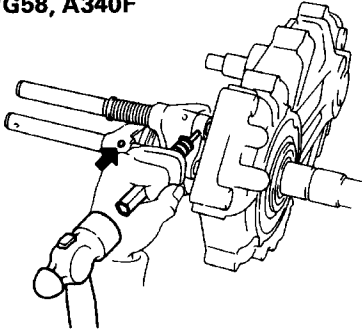

TF0619

(b) Hold the front drive fork shaft in place by hand, when removing the pin punch.

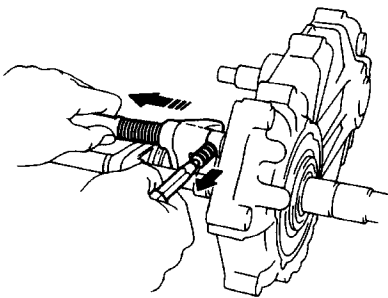

TF0460

(c) Remove the front drive fork shaft, spring and fork.

3VZ-E/R150F

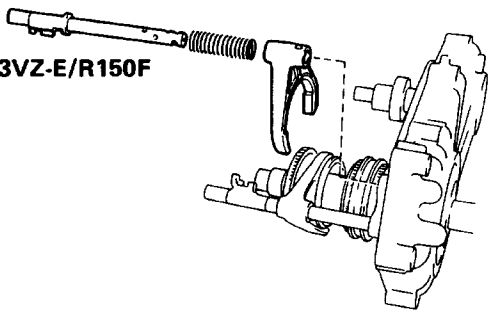

TF0461

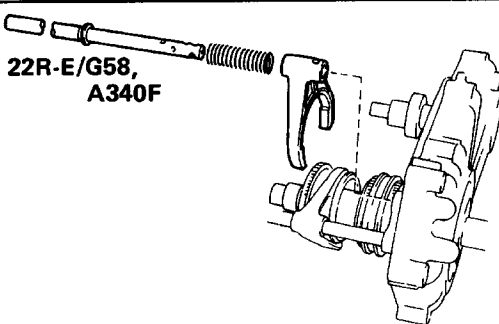
22R-E/G58,  
A340F

TF0623

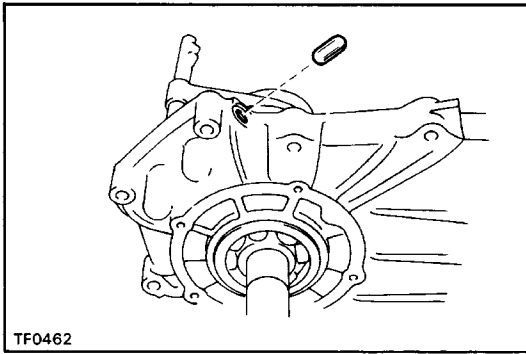

(d) Using a magnetic finger, remove the straight pin.

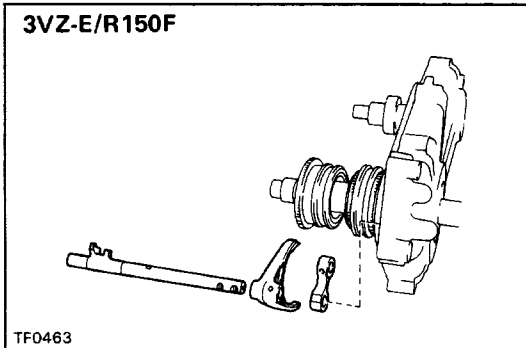

#### 14. REMOVE HIGH AND LOW FORK SHAFT, FORK AND STOPPER

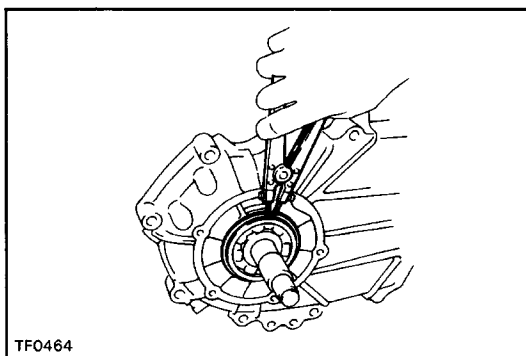
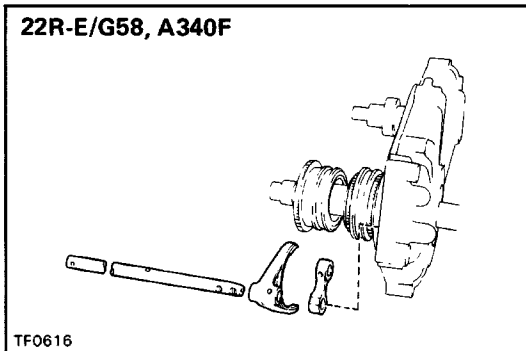

#### 15. REMOVE REAR OUTPUT SHAFT, DRIVEN SPROCKET AND CHAIN

(a) Using snap ring pliers, remove the snap ring.

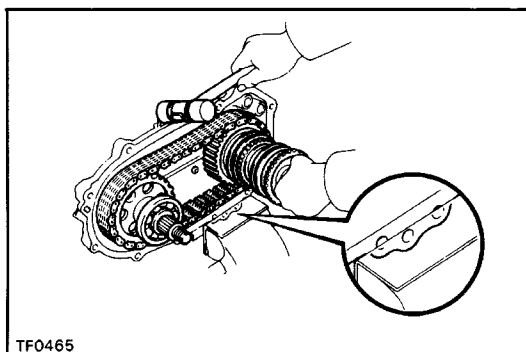

(b) Mount the rear case in the vise.

**NOTICE: Be careful not to damage the sealing surface.**

(c) Using a plastic hammer, tap the rear case with pulling the rear output shaft and driven sprocket.

(d) Remove the chain.

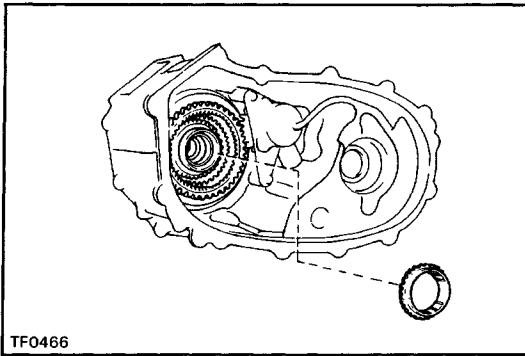

**16. (13150F, G58)**  
**REMOVE SYNCHRONIZER RING FROM INPUT SHAFT**

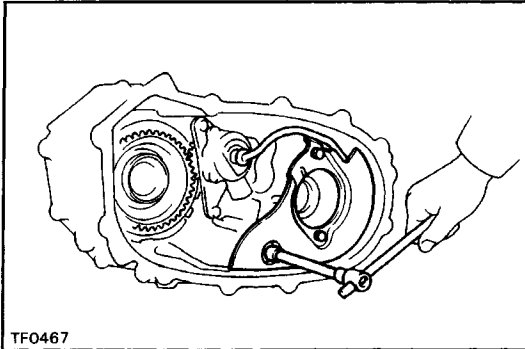

**17. REMOVE SEPARATER WITH OIL STRAINER**  
 (a) Remove the three bolts and the separator with the oil strainer.  
 (b) Remove the O-ring from the oil strainer pipe.

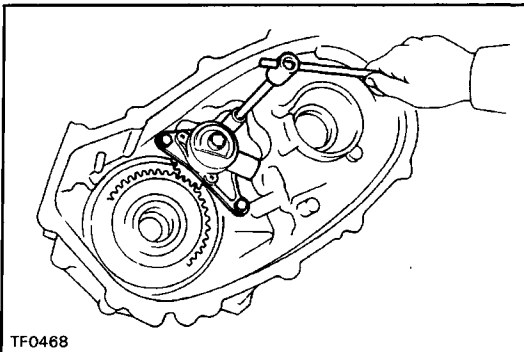

**18. REMOVE OIL PUMP BODY ASSEMBLY**  
 Remove the three bolts and the oil pump body assembly.

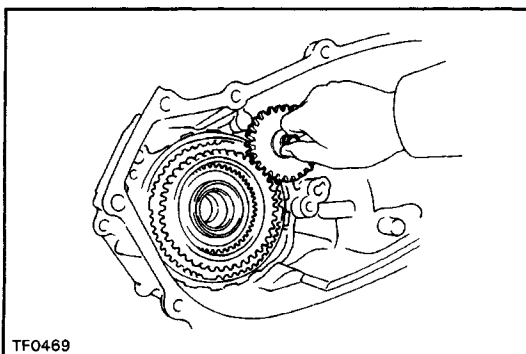

**19. REMOVE OIL PUMP DRIVE GEAR**

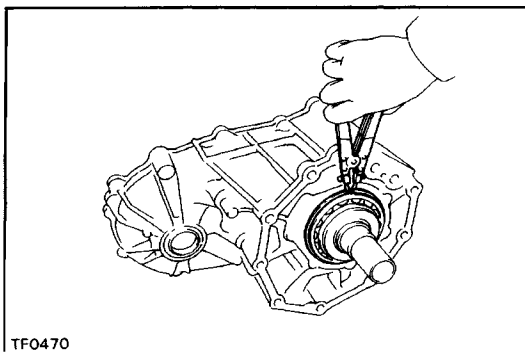

**20. REMOVE PLANETARY GEAR ASSEMBLY WITH INPUT SHAFT**

(a) Using snap ring pliers, remove the snap ring.

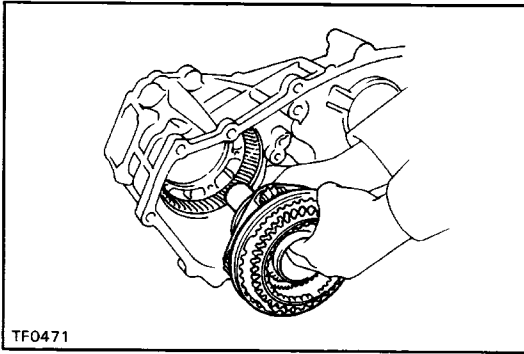

(b) Pull out the planetary gear assembly with the input shaft.

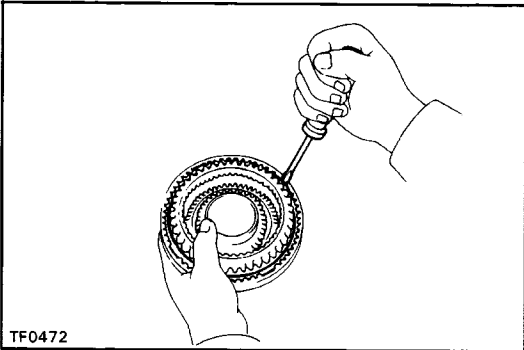

### 21. REMOVE LOW GEAR SPLINE PIECE

(a) Using a screwdriver, remove the snap ring.

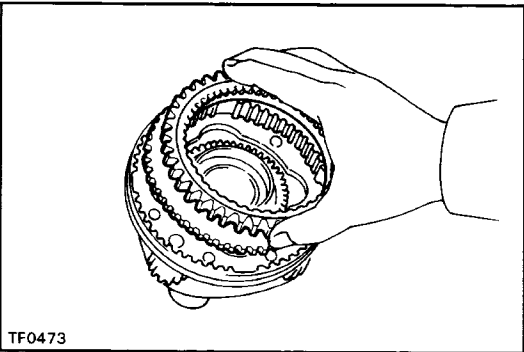

(b) Remove the low gear spline piece.

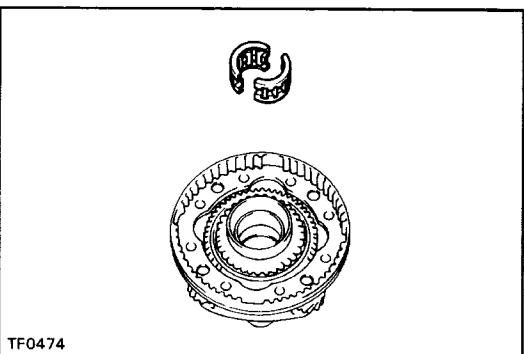

### 22. REMOVE NEEDLE ROLLER BEARING FROM INPUT SHAFT

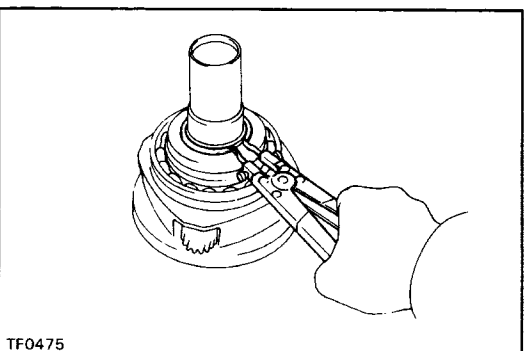

### 23. REMOVE INPUT SHAFT STOPPER AND THRUST BEARING

(a) Using snap ring pliers, remove the snap ring.

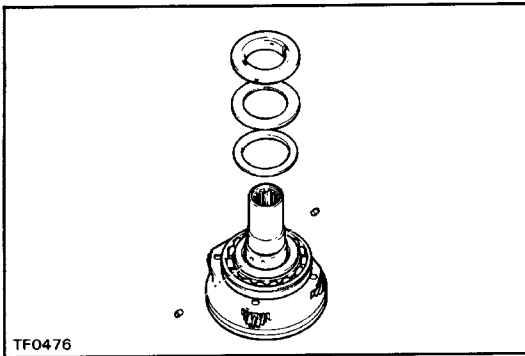

(b) Remove the input shaft stopper, thrust bearing, race and the two pins.

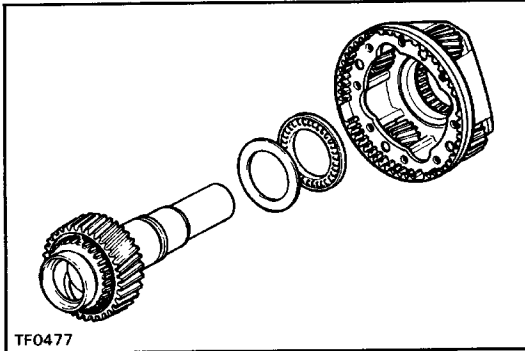

## 24. REMOVE INPUT SHAFT, THRUST BEARING AND RACE

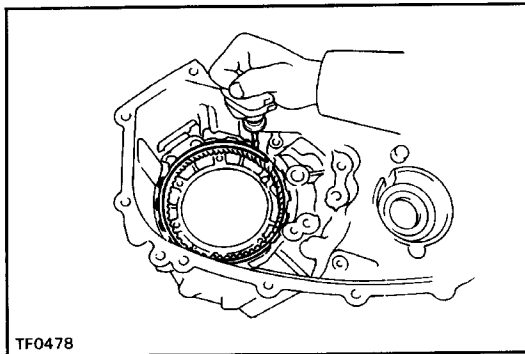

## 25. REMOVE PLANETARY RING GEAR

(a) Using a screwdriver, remove the snap ring.

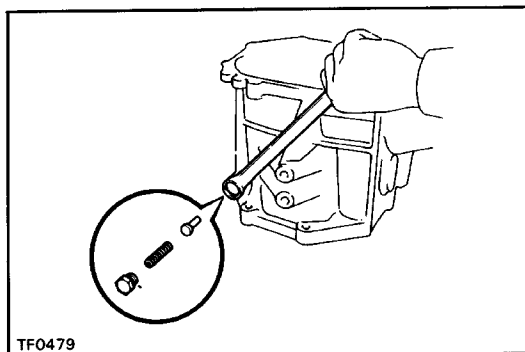

(b) Remove the plug, spring and pin.

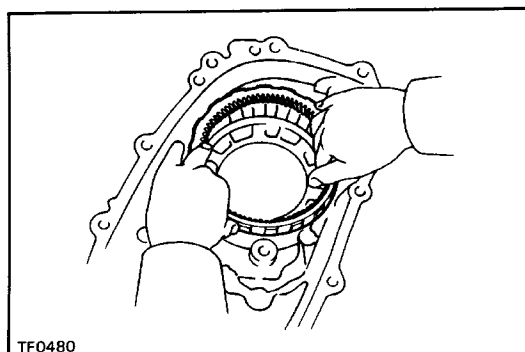

(c) Remove the planetary ring gear.

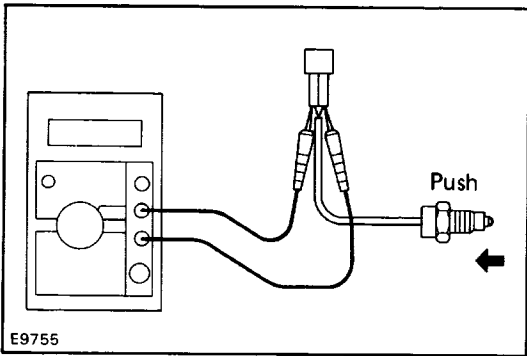

**26. INSPECT TRANSFER INDICATOR SWITCH**

Check that there is continuity between terminals as shown.

Switch Position	Specified
Push	Continuity
Free	No continuity

If operation is not as specified, replace the switch.

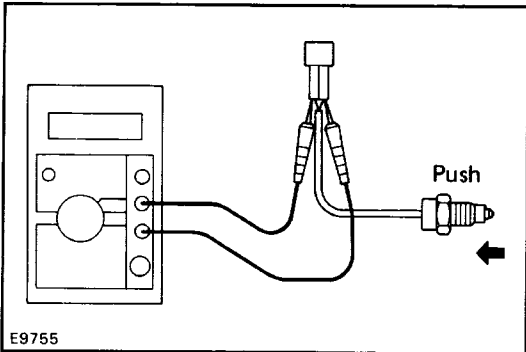

**27. (22R-E/A340F) INSPECT TRANSFER L4 AND NEUTRAL POSITION SWITCH**

Check that there is continuity between terminals as shown.

Switch Position	Specified
Push	Continuity
Free	No continuity

If operation is not as specified, replace the switch.

# COMPONENT PARTS

## Oil Pump Body

### COMPONENTS

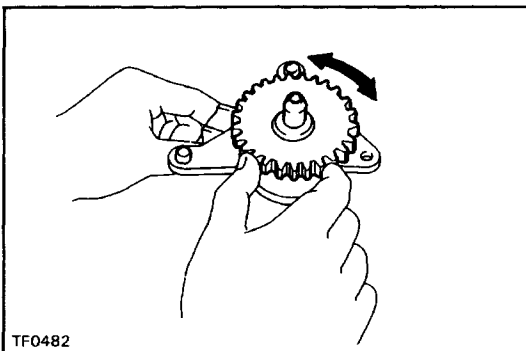
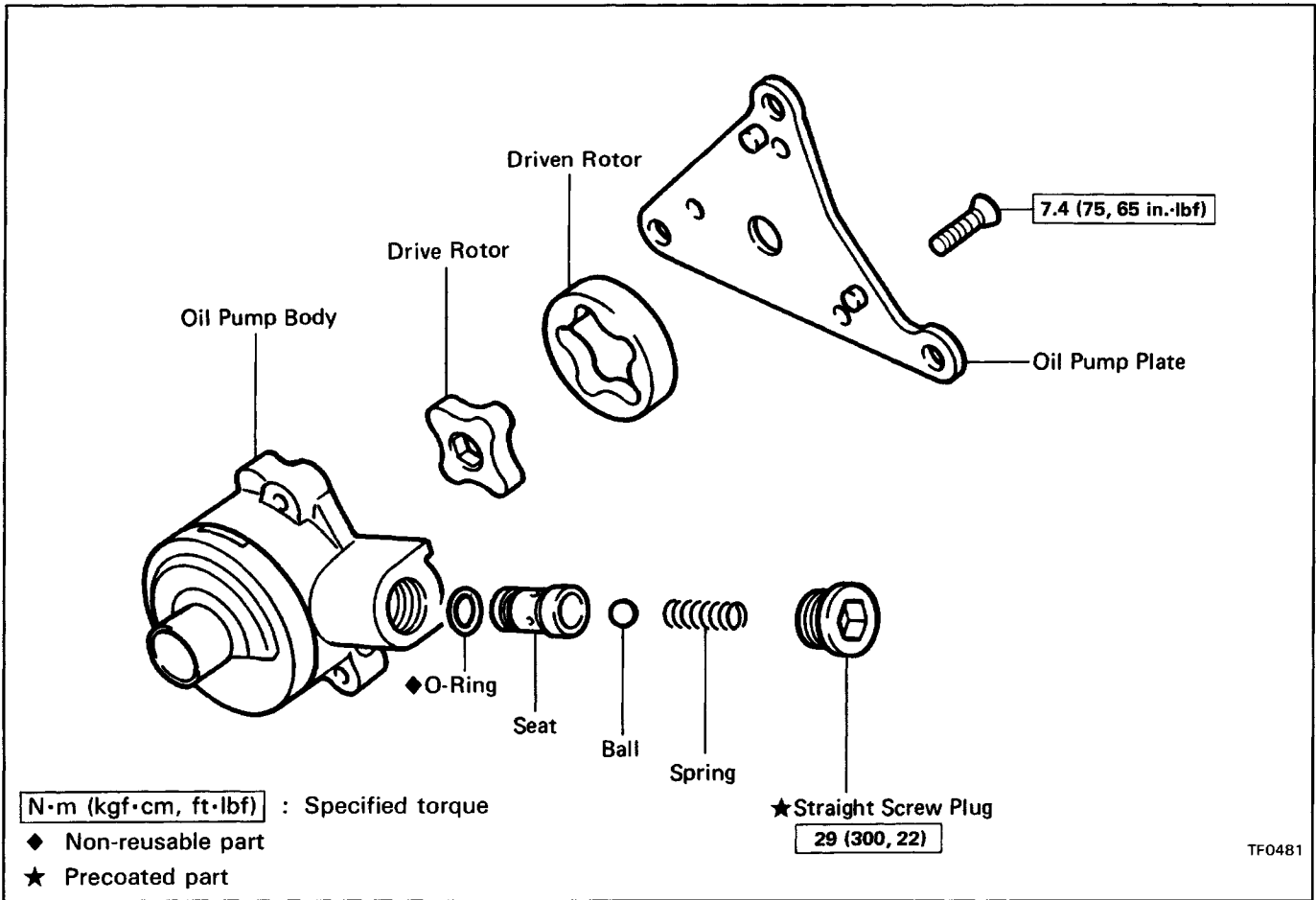

#### DISASSEMBLY OF OIL PUMP BODY

##### 1. CHECK OPERATION OF OIL PUMP

Install the oil pump drive gear to the drive rotor, check that the drive rotor turns smoothly.

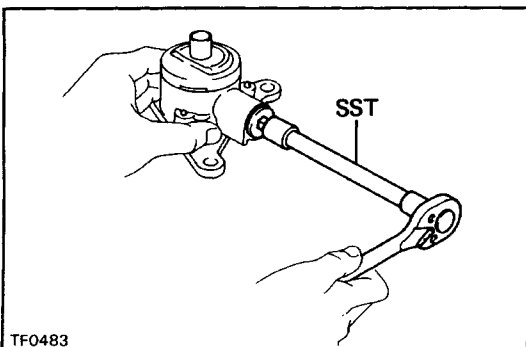

##### 2. REMOVE STRAIGHT SCREW PLUG, SPRING, BALL AND SEAT

(a) Using SST, remove the straight screw plug.  
SST 09043-38100

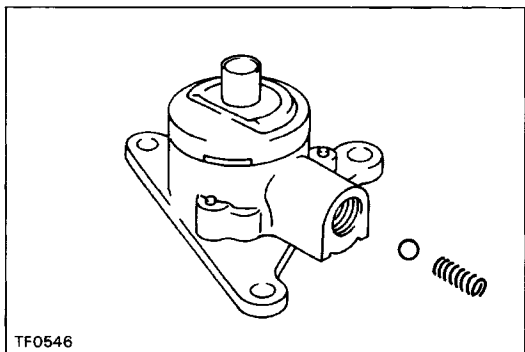

(b) Using a magnetic finger, remove the spring and ball.

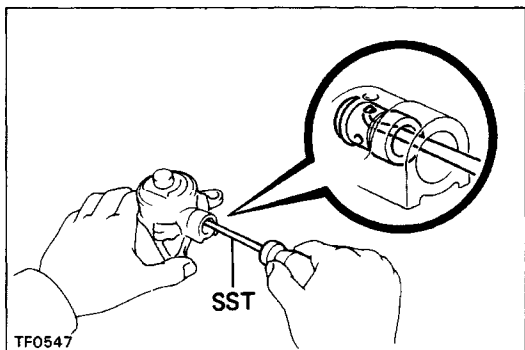

(c) Using SST, pull out the seat.

SST 09921-00010

(d) Remove the O-ring from the seat.

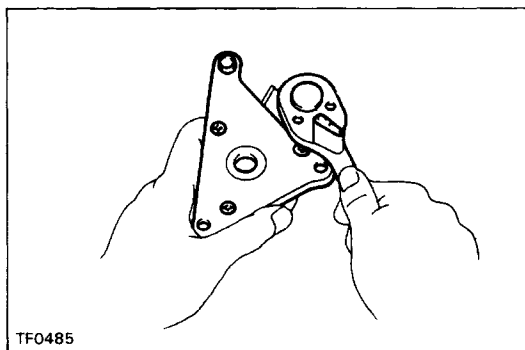

### 3. REMOVE OIL PUMP PLATE

(a) Using a torx socket wrench, unscrew the three torx screws.

(Torx socket wrench T30 09042-00010)

(b) Remove the oil pump plate.

### 4. REMOVE DRIVE ROTOR AND DRIVEN ROTOR

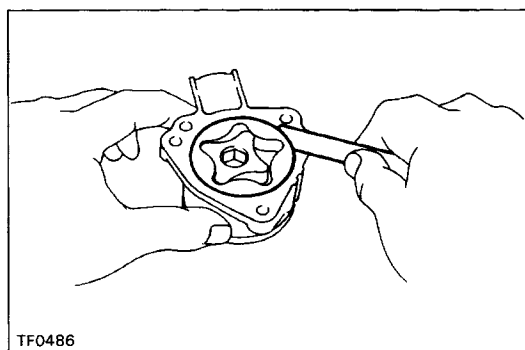

## INSPECTION OF OIL PUMP BODY

### 1. CHECK BODY CLEARANCE OF DRIVEN ROTOR

Push the driven rotor to one side of the body.

Using a feeler gauge, measure the clearance.

**Standard clearance: 0.10 – 0.16 mm**

**(0.0039 – 0.0063 in.)**

**Maximum clearance: 0.16 mm (0.0063 in.)**

If the clearance exceeds the limit, replace the drive rotor, driven rotor or pump body.

### 2. CHECK TIP CLEARANCE OF BOTH ROTORS

Using a feeler gauge, measure the clearance between both rotor tips.

**Standard clearance: 0.08 – 0.16 mm**

**(0.0031 – 0.0063 in.)**

**Maximum clearance: 0.16 mm (0.0063 in.)**

If the clearance exceeds the limit, replace the drive rotor, driven rotor or pump body.

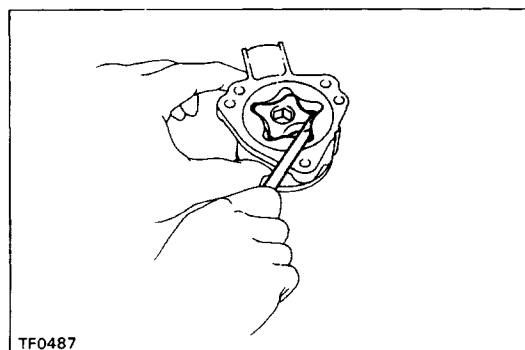



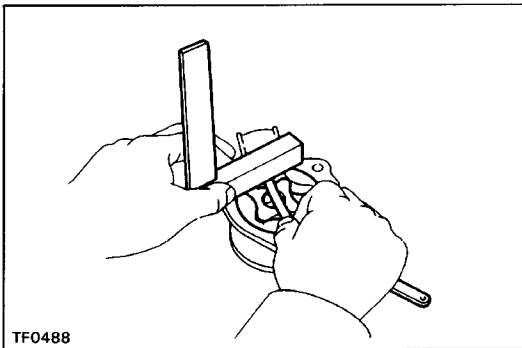

### 3. CHECK SIDE CLEARANCE OF BOTH ROTORS

Using a steel straight edge and feeler gauge, measure the clearance between the rotors and straight edge.

**Standard clearance: 0.03 – 0.08 mm**

**(0.0012 – 0.0031 in.)**

**Maximum clearance: 0.08 mm (0.0031 in.)**

If the clearance exceeds the limit, replace the drive rotor, driven rotor or pump body.

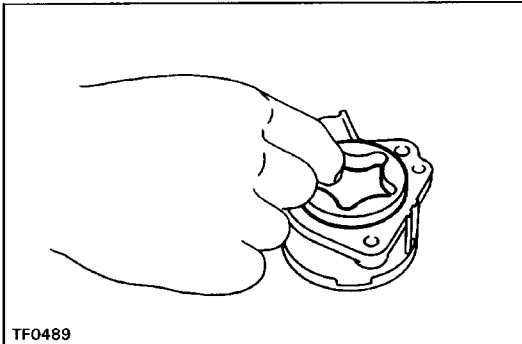

### ASSEMBLY OF OIL PUMP BODY

#### 1. INSTALL OIL PUMP DRIVE ROTOR AND DRIVEN ROTOR

- (a) Apply gear oil to the both rotors.
- (b) Install the driven rotor.

- (c) Install the drive rotor.

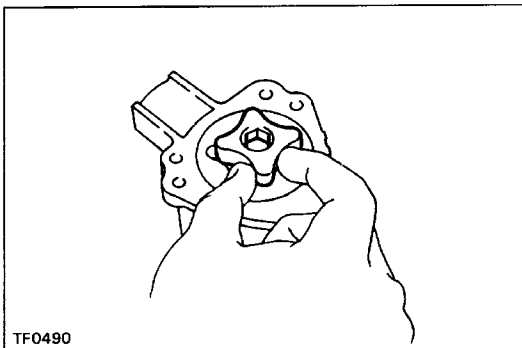

#### 2. INSTALL OIL PUMP PLATE

- (a) Install the oil pump plate.
- (b) Using a torx socket wrench, tighten the three torx screws.

(Torx socket wrench T30 09042-00010)

**Torque: 7.4 N-m (75 kgf-cm, 65 in.-lbf)**

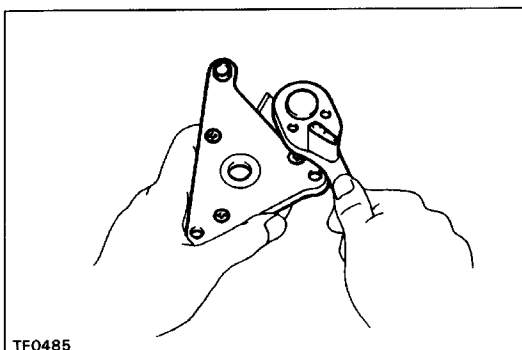

#### 3. INSTALL SEAT, BALL, SPRING AND STRAIGHT SCREW PLUG

- (a) Install a new O-ring to the seat.
- (b) Install the seat, ball and spring.

**HINT:** When installing the seat, push the seat until it touches the bottom of the hole in the body.

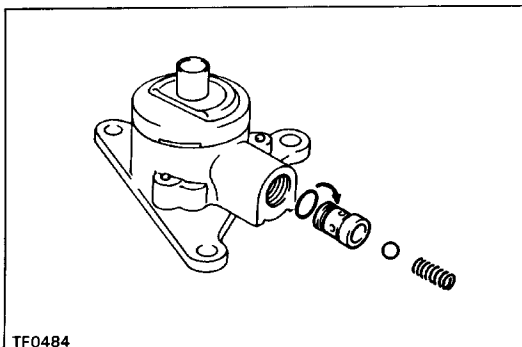

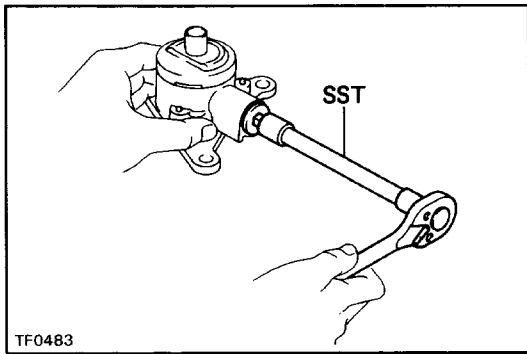

(c) Apply liquid sealer to the plug.

**Sealant: Part No. 08833-00080, THREE BOND 1344,  
LOCTITE 242 or equivalent**

(d) Using SST, torque the plug.

SST 09043-38100

**Torque: 29 N-m (300 kgf-cm, 22 ft-lbf)**

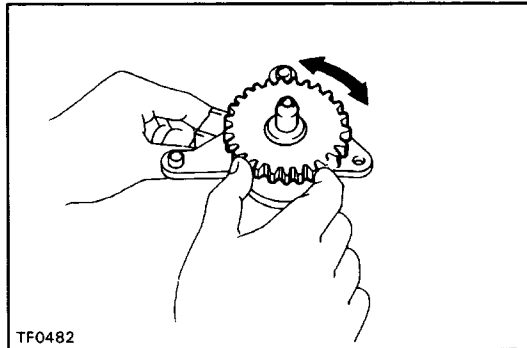

#### 4. CHECK OPERATION OF OIL PUMP

Install the oil pump drive gear to the drive rotor, check that the drive rotor turns smoothly.

# Driven Sprocket COMPONENTS

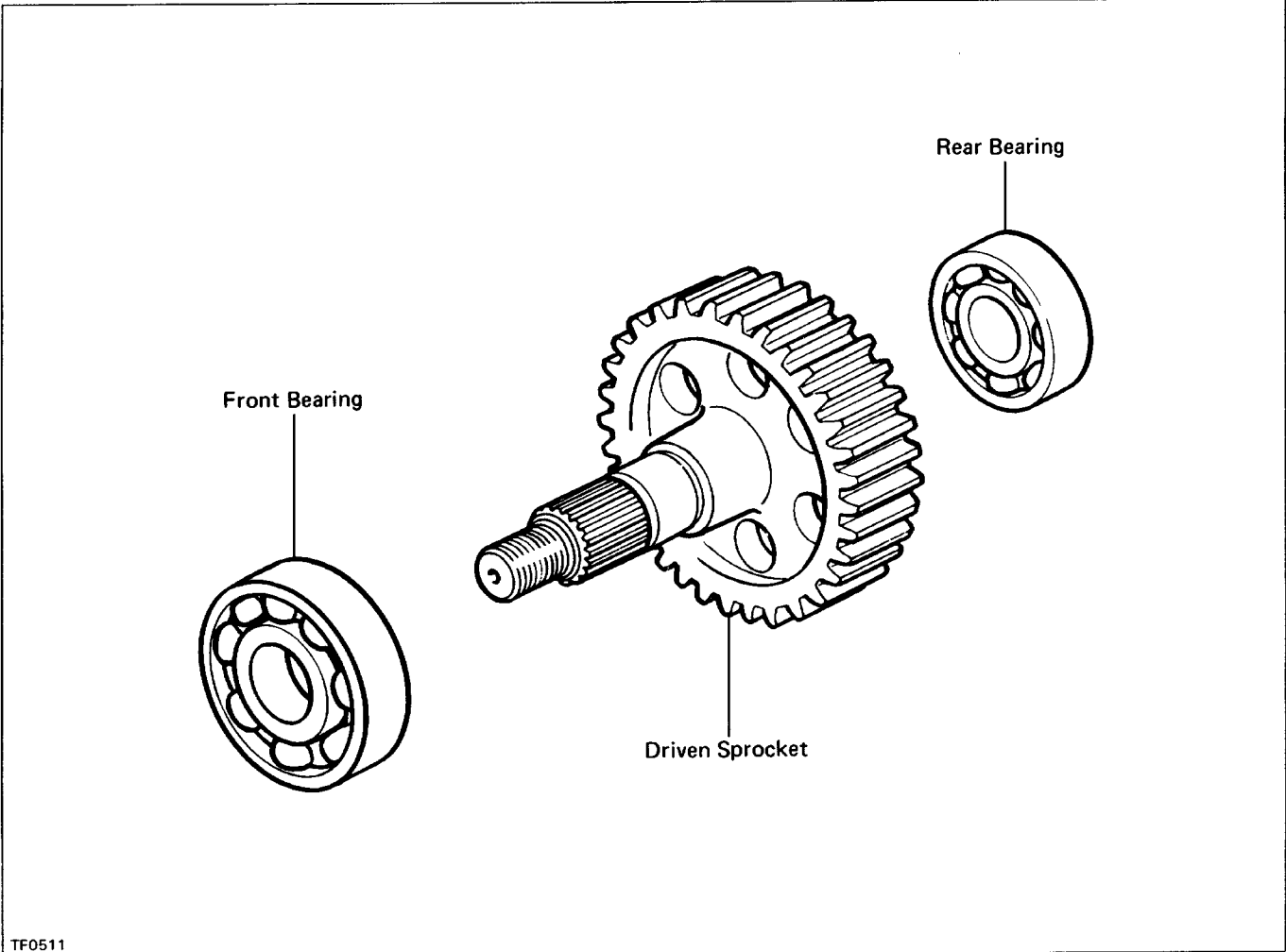

TF0511

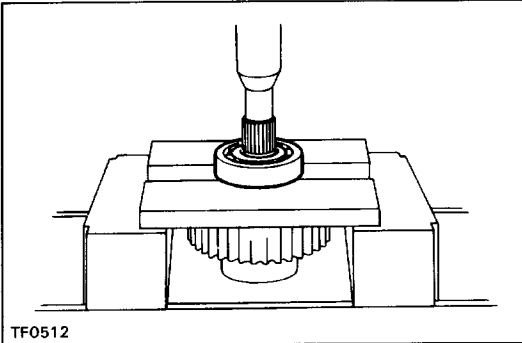

TF0512

### DISASSEMBLY OF DRIVEN SPROCKET

#### 1. REMOVE FRONT BEARING

Using a press, remove the front bearing.

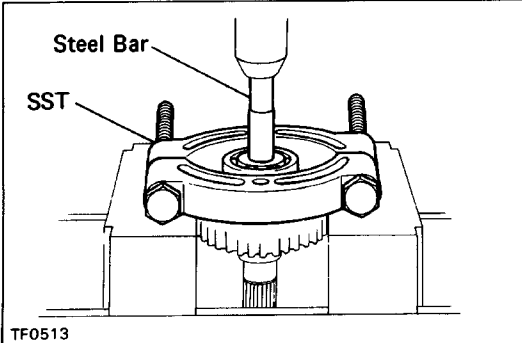

TF0513

#### 2. REMOVE REAR BEARING

Using SST and a press, remove the rear bearing.  
SST 09950-00020

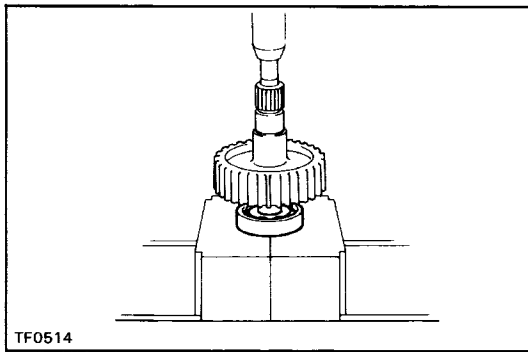

## ASSEMBLY OF DRIVEN SPROCKET

### 1. INSTALL REAR BEARING

Using a press, install the rear bearing.

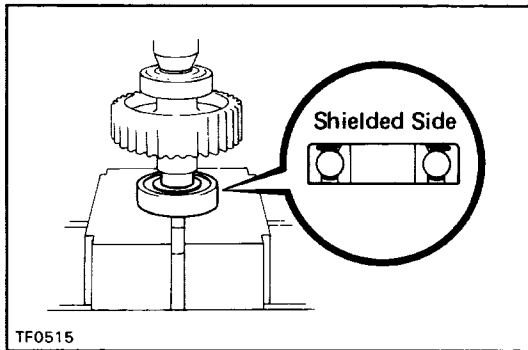

### 2. INSTALL FRONT BEARING

Using a press, install the front bearing.

HINT: Make sure to install the bearing in the correct direction.

# Rear Output Shaft Assembly COMPONENTS

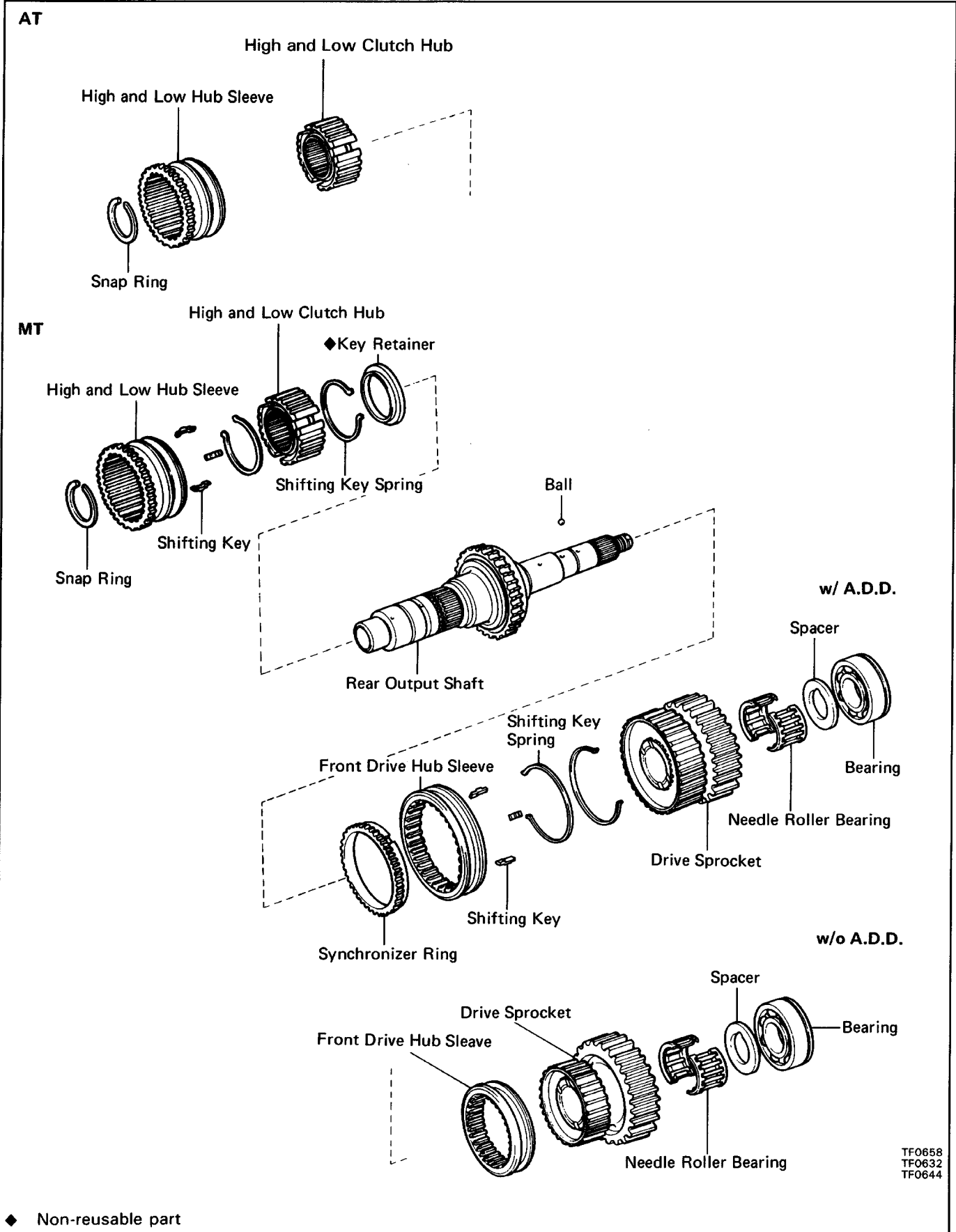

TF0658  
TF0632  
TF0644

## DISASSEMBLY OF REAR OUTPUT SHAFT ASSEMBLY

### 1. MEASURE DRIVE SPROCKET THRUST CLEARANCE

Using a feeler gauge, measure the drive sprocket thrust clearance.

**Standard clearance: 0.10 – 0.25 mm**

**(0.0039 – 0.0098 in.)**

**Maximum clearance: 0.25 mm (0.0098 in.)**

If the clearance exceeds the limit, replace the drive sprocket.

### 2.-1 (MT)

#### REMOVE HIGH AND LOW HUB SLEEVE ASSEMBLY

(a) Using snap ring pliers, remove the snap ring.

(b) Remove the hub sleeve and shifting keys.

(c) Using a press, remove the clutch hub, key springs and key retainer.

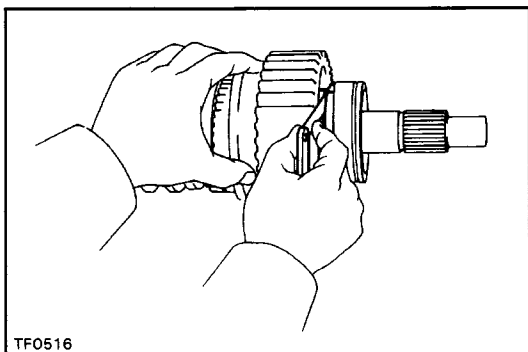

TF0516

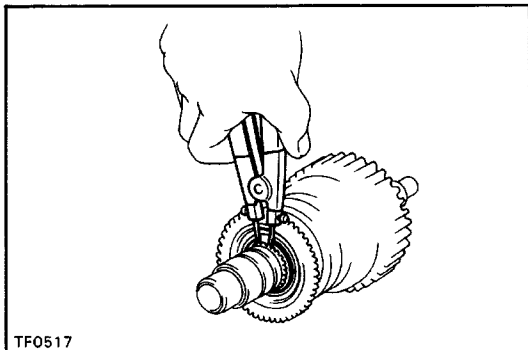

TF0517

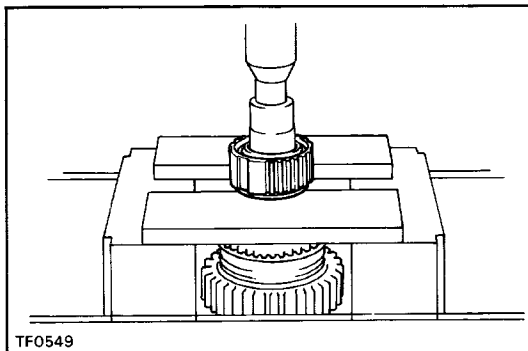

TF0549

### 2.-2 (AT)

#### REMOVE HIGH AND LOW HUB SLEEVE ASSEMBLY

(a) Using snap ring pliers, remove the snap ring.

(b) Remove the hub sleeve.

(c) Using a press, remove the clutch hub.

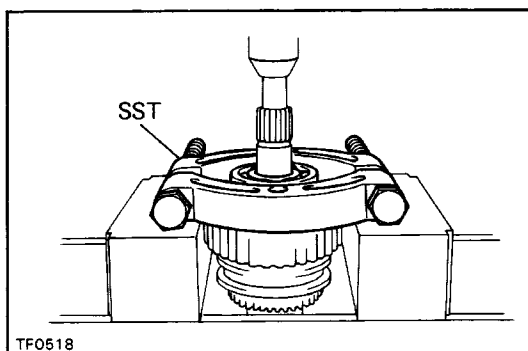

TF0518

### 3.-1 (w/ A.D.D.)

#### REMOVE REAR BEARING, SPACER AND DRIVE SPROCKET WITH FRONT DRIVE HUB SLEEVE ASSEMBLY

(a) Using SST and a press, remove the bearing.

SST 09950-00020

(b) Remove the spacer and ball.

(c) Remove the drive sprocket with front drive hub and hub sleeve.

(d) Remove the needle roller bearing.

(e) Remove the synchronizer ring.

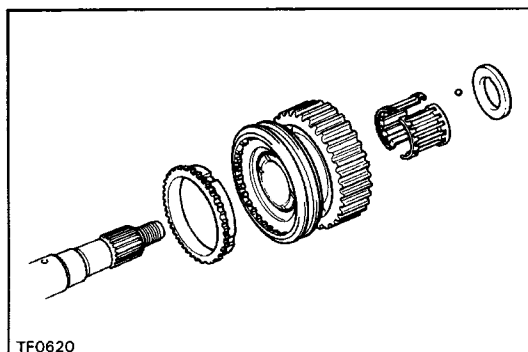

TF0620

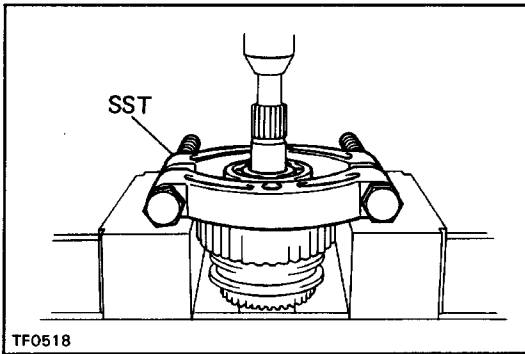

**3.-2 (w/o A.D.D.)  
REMOVE REAR BEARING, SPACER AND DRIVE  
SPROCKET WITH FRONT DRIVE HUB SLEEVE  
ASSEMBLY**

(a) Using SST and a press, remove the bearing.  
SST 09950-00020

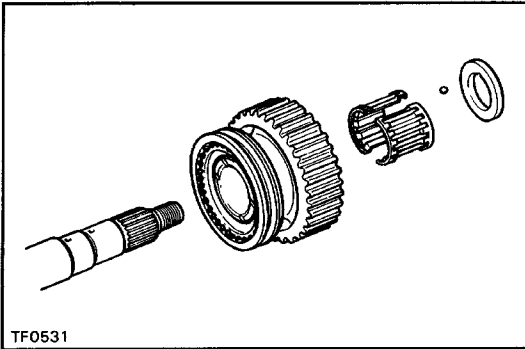

- (b) Remove the spacer and ball.  
(c) Remove the drive sprocket with front drive hub and hub sleeve.  
(d) Remove the needle roller bearing.

**4. (w/ A.D.D.)  
REMOVE SHIFTING KEYS AND KEY SPRINGS FROM  
FRONT DRIVE HUB ASSEMBLY**

Using screwdriver, remove the two shifting key springs and three shifting keys.

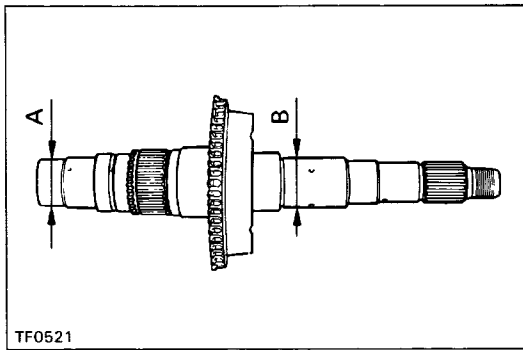

## INSPECTION OF REAR OUTPUT SHAFT ASSEMBLY

### 1. INSPECT REAR OUTPUT SHAFT

Using a micrometer, measure the outer diameter of the rear output shaft journal surface.

Minimum diameter:

**Part A 27.98 mm (1.1016 in.)**

**B 36.98 mm (1.4559 in.)**

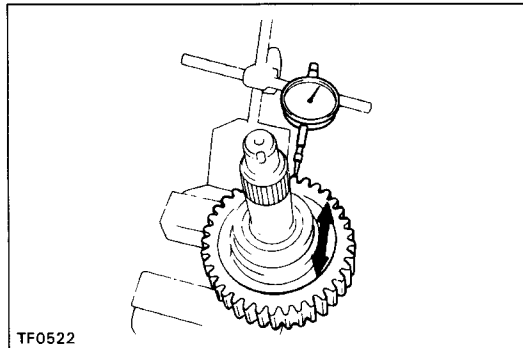

### 2. CHECK OIL CLEARANCE OF DRIVE SPROCKET

Using a dial indicator, measure the oil clearance between the sprocket and shaft with the needle roller bearing installed.

**Standard clearance: 0.010 – 0.055 mm  
(0.0004 – 0.0022 in.)**

**Maximum clearance: 0.055 mm (0.022 in.)**

If the clearance exceeds the limit, replace the drive sprocket, rear output shaft or needle roller bearing.

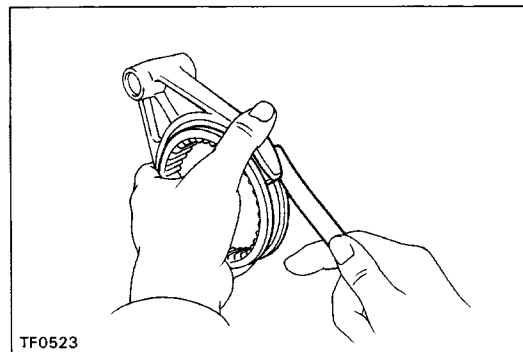

### 3. MEASURE CLEARANCE OF FRONT DRIVE SHIFT FORK AND HUB SLEEVE

Using a feeler gauge, measure the clearance between the front drive shift fork and hub sleeve.

**Maximum clearance: 1.0 mm (0.039 in.)**

If the clearance exceeds the limit, replace the shift fork or hub sleeve.

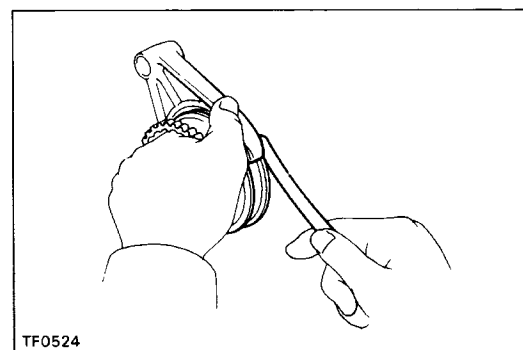

### 4. MEASURE CLEARANCE OF HIGH AND LOW SHIFT FORK AND HUB SLEEVE

Using a feeler gauge, measure the clearance between the high and low shift fork and hub sleeve.

**Maximum clearance: 1.0 mm (0.039 in.)**

If the clearance exceeds the limit, replace the shift fork or hub sleeve.



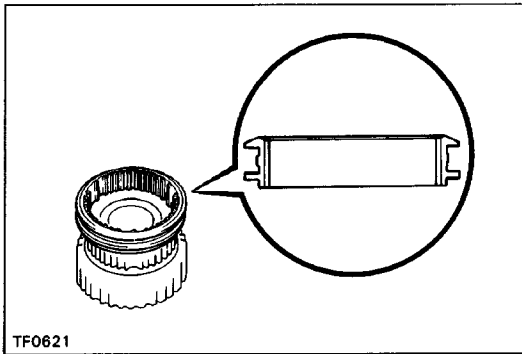

TF0621

**ASSEMBLY OF REAR OUTPUT SHAFT****ASSEMBLY****1.-1 (w/ A.D.D.)****INSTALL FRONT DRIVE CLUTCH HUB AND HUB SLEEVE**

(a) Install the front drive hub sleeve onto the clutch hub.

HINT: Make sure to install the hub sleeve in the correct direction.

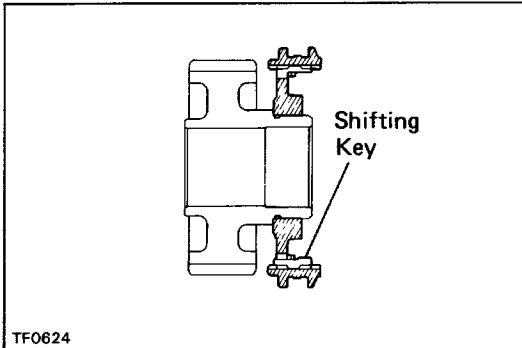

TF0624

(b) Install the shifting keys and springs.

**NOTICE: Install the key springs positioned so that their end gaps are not in line.**

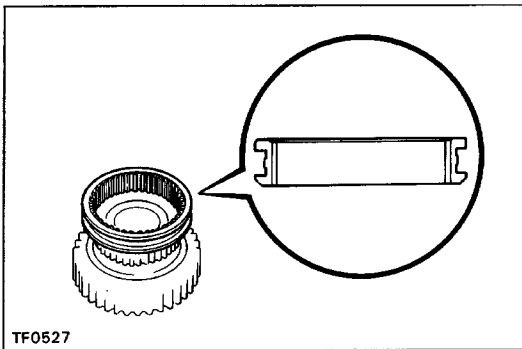

TF0527

**1.-2 (w/o A.D.D.)****INSTALL FRONT DRIVE CLUTCH HUB AND HUB SLEEVE**

Install the front drive hub sleeve onto the clutch hub.

HINT: Make sure to install the hub sleeve in the correct direction.

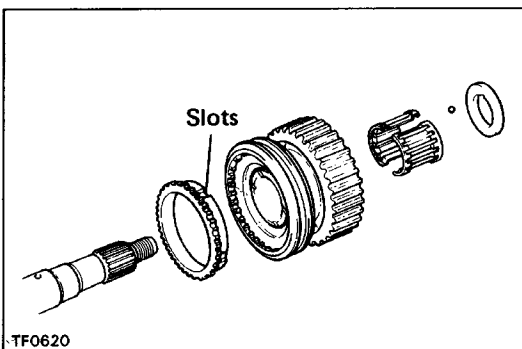

TF0620

**2.-1 (w/ A.D.D.)****INSTALL DRIVE SPROCKET WITH FRONT DRIVE HUB SLEEVE ASSEMBLY, SPACER AND REAR BEARING**

(a) Apply gear oil to the shaft and needle roller bearing.

(b) Install the synchronizer ring.

(c) Install the needle roller bearing in the drive sprocket.

(d) Install the drive sprocket with the front drive hub sleeve.

(e) Place the synchronizer ring on the gear and align the ring slots with the shifting keys.

(f) Install the spacer to align it with the ball.

(g) Using SST and a press, install the rear bearing with the outer race snap ring groove toward the rear.

SST 09316-60010 (09316-00010, 09316-00070)

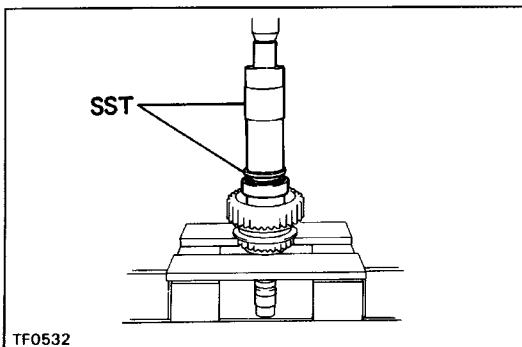

TF0532

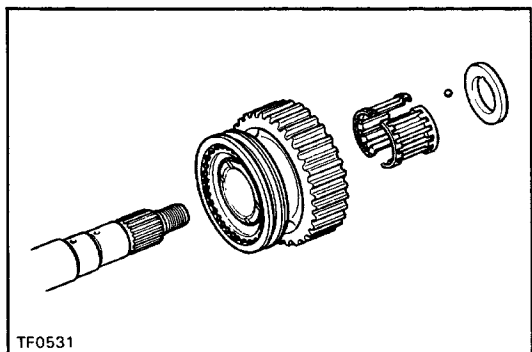

TF0531

**2.-2 (w/o A.D.D.)****INSTALL DRIVE SPROCKET WITH FRONT DRIVE HUB SLEEVE ASSEMBLY, SPACER AND REAR BEARING**

- (a) Apply gear oil to the shaft and needle roller bearing.
- (b) Install the needle roller bearing in the drive sprocket.
- (c) Install the drive sprocket with the front drive hub sleeve.
- (d) Install the spacer to align it with the ball.

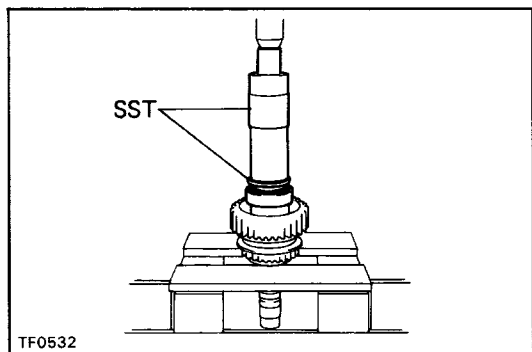

TF0532

- (e) Using SST and a press, install the rear bearing with the outer race snap ring groove toward the rear.  
SST 09316-60010 (09316-00010, 09316-00070)

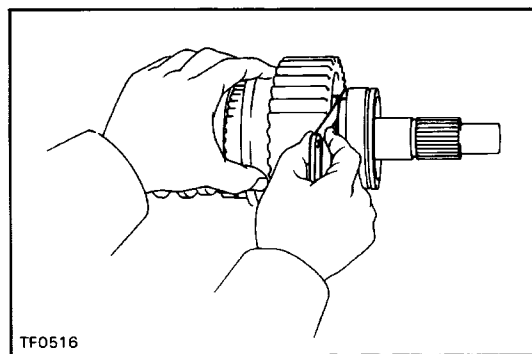

TF0516

**3. MEASURE DRIVE SPROCKET THRUST CLEARANCE**

Using a feeler gauge, measure the drive sprocket thrust clearance.

**Standard clearance: 0.10 – 0.25 mm**  
**(0.0039 – 0.0098 in.)**

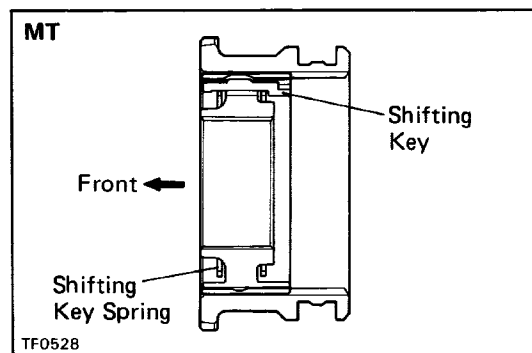

TF0528

**4.-1 (MT)****INSERT HIGH AND LOW CLUTCH HUB INTO HUB SLEEVE**

- (a) Install the clutch hub and shifting keys to the hub sleeve.
- (b) Install the shifting key springs under the shifting keys.

**NOTICE: Install the key springs positioned so that their end gaps are not in line.**

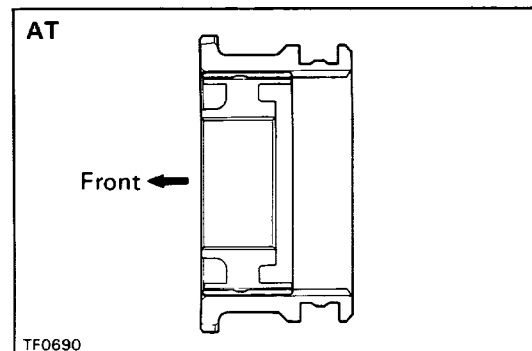

TF0690

**4.-2 (AT)****INSERT HIGH AND LOW CLUTCH HUB INTO HUB SLEEVE**

Install the clutch hub to the hub sleeve.

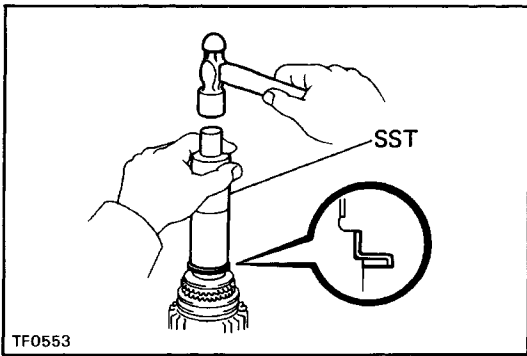

**5.-1 (MT)**

**INSTALL HIGH AND LOW HUB SLEEVE ASSEMBLY**

(a) Using SST and a hammer, drive in a new key retainer.

SST 09316-60010 (09316-00010)

**NOTICE:** Be careful not to deform or damage the key retainer.

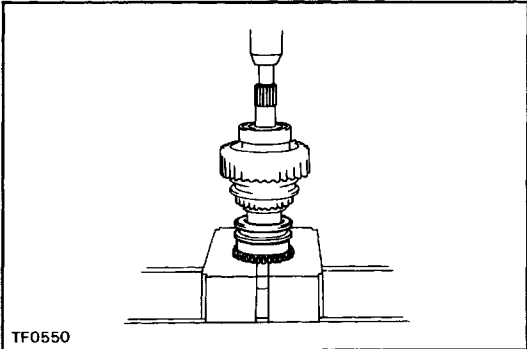

(b) Using a press, install the high and low hub sleeve assembly.

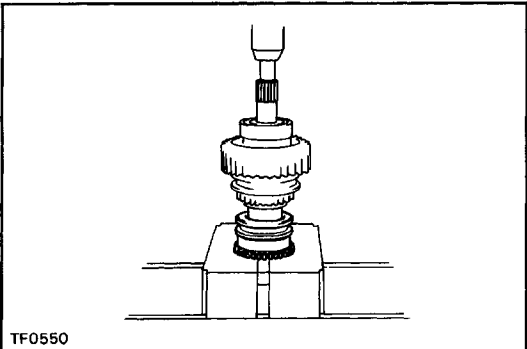

**5.-2 (AT)**

**INSTALL HIGH AND LOW HUB SLEEVE ASSEMBLY**

Using a press, install the high and low hub sleeve assembly.

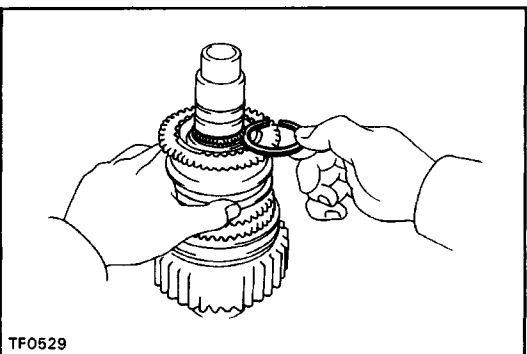

**6. INSTALL SNAP RING**

(a) Select a snap ring that will allow minimum axial play.

Mark	Thickness mm (in.)
A	2.10 – 2.15 (0.0827 – 0.0846)
B	2.15 – 2.20 (0.0846 – 0.0866)
C	2.20 – 2.25 (0.0866 – 0.0886)
D	2.25 – 2.30 (0.0886 – 0.0906)
E	2.30 – 2.35 (0.0906 – 0.0925)
F	2.35 – 2.40 (0.0925 – 0.0945)
G	2.40 – 2.45 (0.0945 – 0.0965)
H	2.45 – 2.50 (0.0965 – 0.0984)
J	2.50 – 2.55 (0.0984 – 0.1004)
K	2.00 – 2.05 (0.0787 – 0.0807)
L	2.05 – 2.10 (0.0807 – 0.0827)

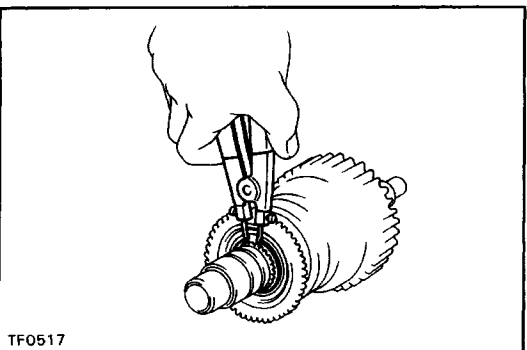

(b) Using snap ring pliers, install the snap ring.

# Input Shaft COMPONENTS

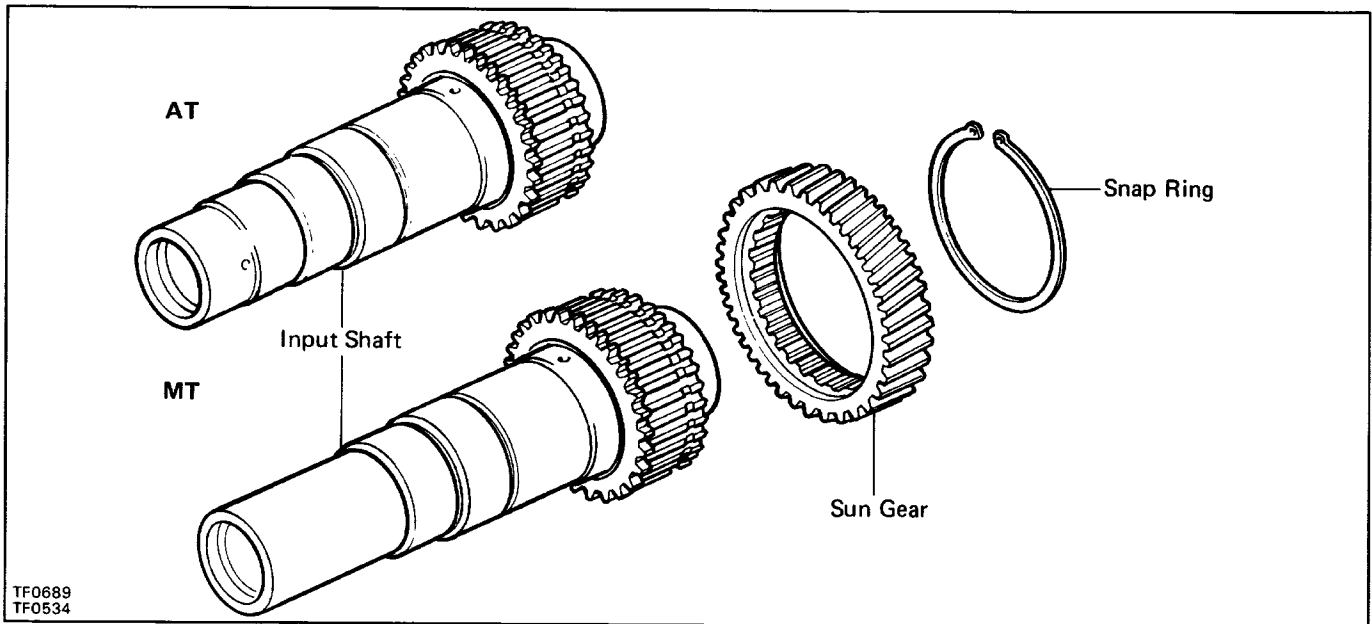

## DISASSEMBLY OF INPUT SHAFT REMOVE SUN GEAR

(a) Using snap ring pliers, remove the snap ring.

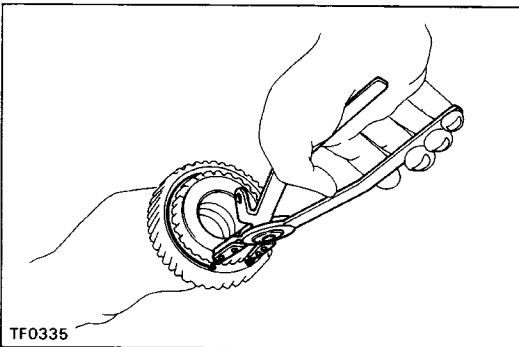

(b) Remove the sun gear from the input shaft.

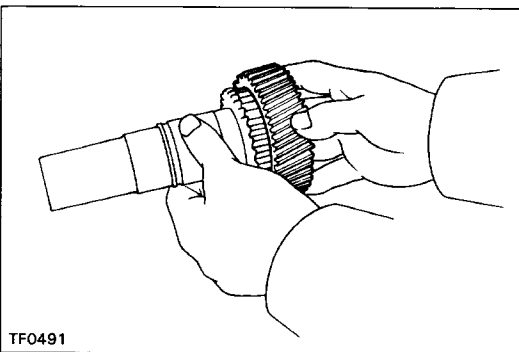

## INSPECTION OF INPUT SHAFT

### 1. INSPECT INPUT SHAFT

(a) Using a micrometer, measure the outer diameter of the input shaft journal surface.

**Minimum diameter: 47.59 mm (1.8736 in.)**

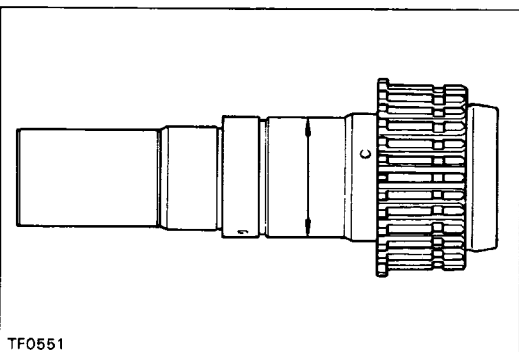

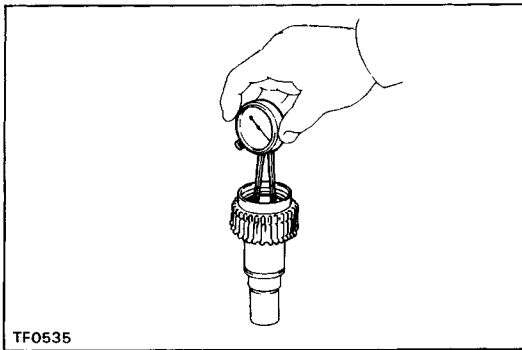

(b) Using a dial indicator, measure the inside diameter of the input shaft bushing.

**Maximum inside diameter: 39.14 mm (1.5409 in.)**

If the inside diameter exceeds the limit, replace the input shaft.

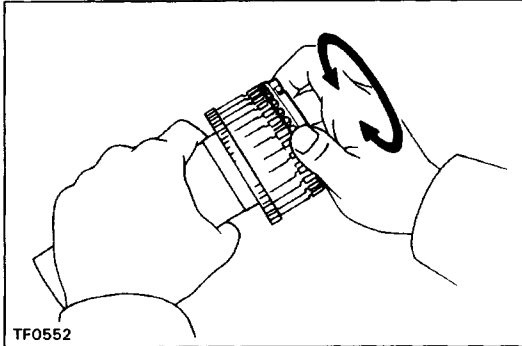

## 2. INSPECT SYNCHRONIZER RING

(a) Turn the ring and push it in to check the braking action.

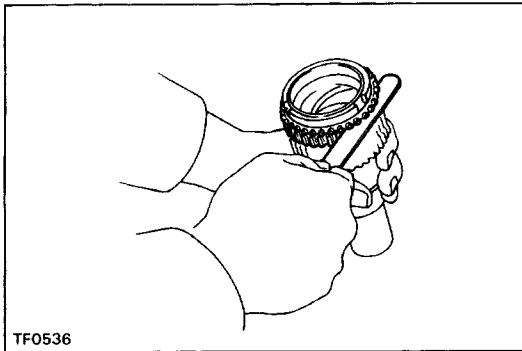

(b) Measure the clearance between the synchronizer ring back and the input shaft spline end.

**Standard clearance: 1.15 – 1.85 mm**

**(0.0453 – 0.0728 in.)**

**Minimum clearance: 0.8 mm (0.031 in.)**

If the clearance is less than the limit, replace the synchronizer ring.

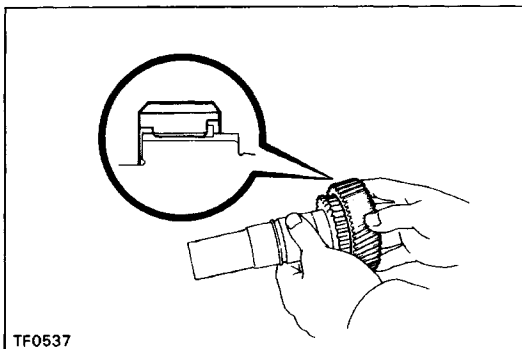

## ASSEMBLY OF INPUT SHAFT INSTALL SUN GEAR

(a) Install the sun gear to the input shaft.

HINT: Make sure to install the sun gear in the correct direction.

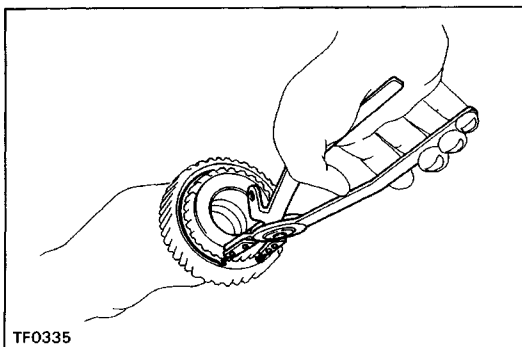

(b) Using snap ring pliers, install the snap ring.

# Planetary Gear COMPONENTS

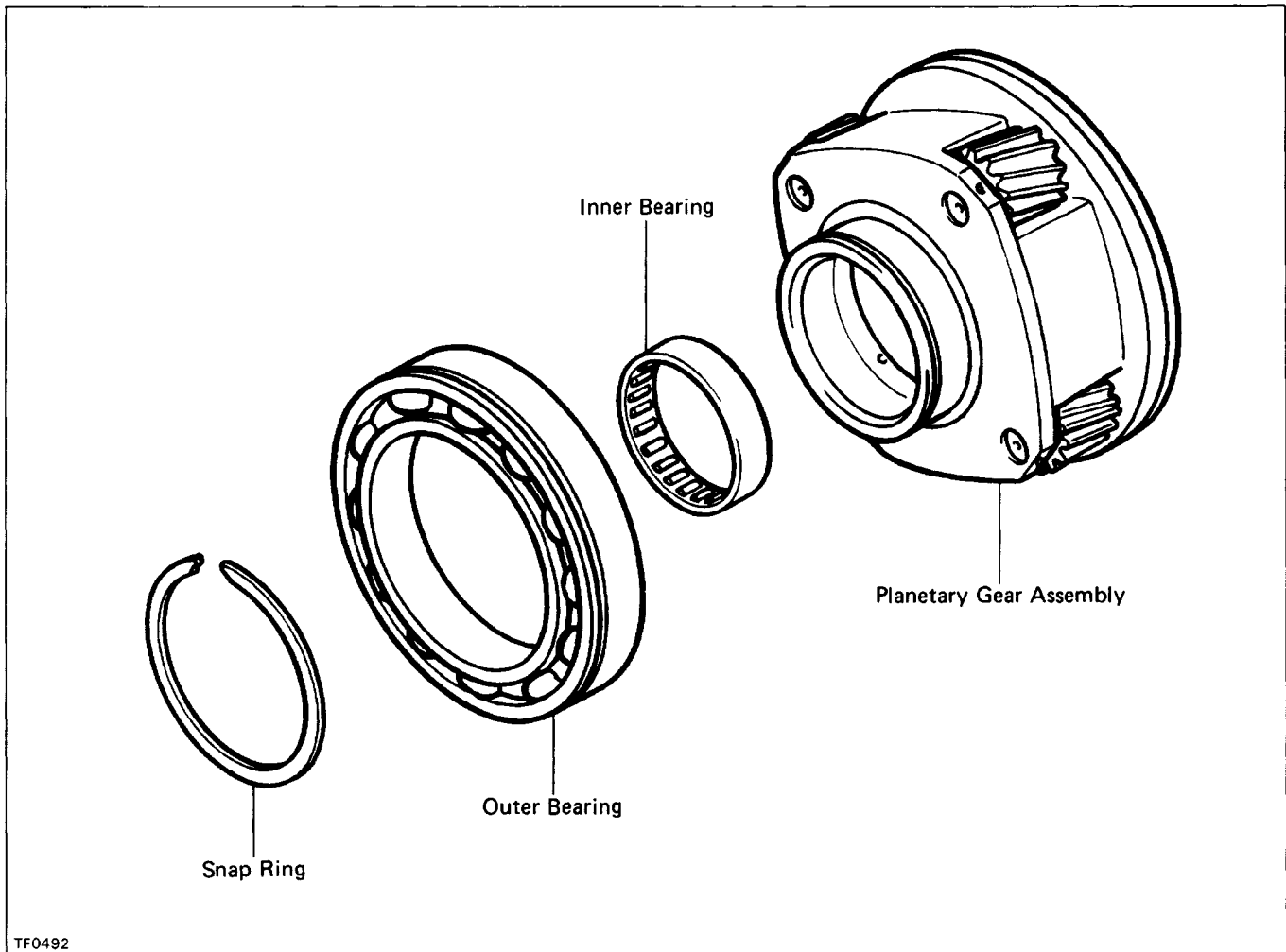

TF0492

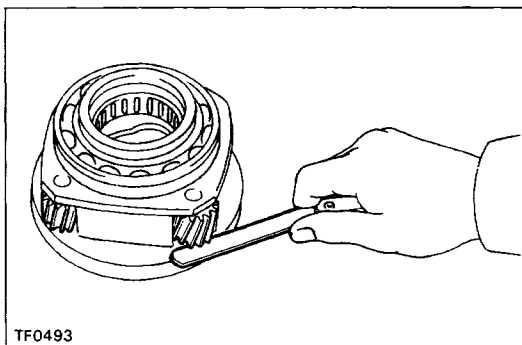

TF0493

## INSPECTION OF PLANETARY GEAR

### 1. MEASURE PLANETARY PINION GEAR THRUST CLEARANCE

Using a feeler gauge, measure the planetary pinion gear thrust clearance.

**Standard clearance: 0.11 – 0.86 mm**  
(0.0043 – 0.0339 in.)

**Maximum clearance: 0.86 mm (0.0339 in.)**

If the clearance exceeds the limit, replace the planetary gear assembly.

### 2. CHECK OIL CLEARANCE OF PLANETARY PINION GEAR

Using a dial indicator, measure the oil clearance of the planetary pinion gear.

**Standard clearance: 0.009 – 0.038 mm**  
(0.0004 – 0.0015 in.)

**Maximum clearance: 0.038 mm (0.0015 in.)**

If the clearance exceeds the limit, replace the planetary gear assembly.

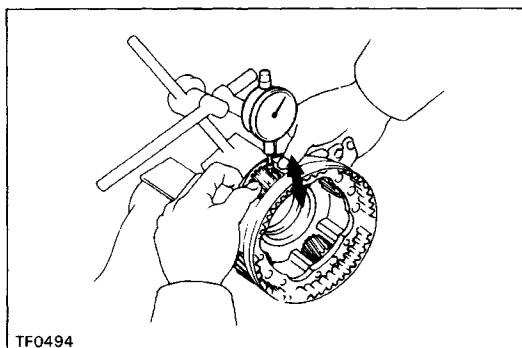

TF0494

**3. IF NECESSARY, REPLACE PLANETARY GEAR OUTER BEARING**

(a) Using snap ring pliers, remove the snap ring.

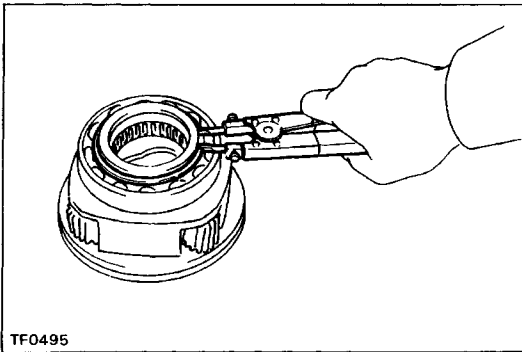

(b) Using SST and a press, remove the bearing.  
SST 09554-30011 and 09555-55010

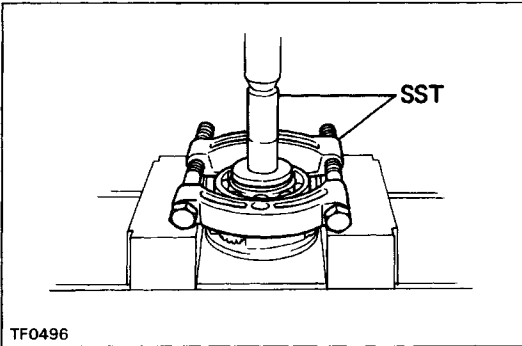

(c) Using SST and a press, install a new bearing with the outer race snap ring groove toward the front.  
SST 09223-15010 and 09515-30010

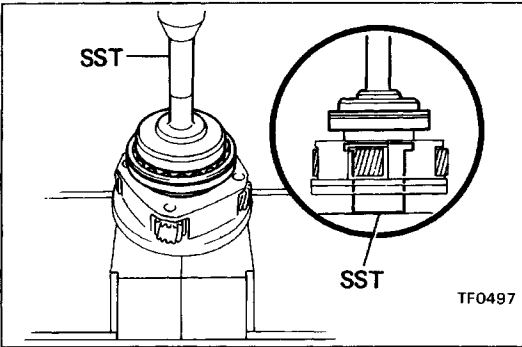

(d) Select a snap ring that will allow minimum axial play.

Mark	Thickness	mm (in.)
1	1.45 – 1.50	(0.0571 – 0.0591)
2	1.50 – 1.55	(0.0591 – 0.0610)
3	1.55 – 1.60	(0.0610 – 0.0630)
4	1.60 – 1.65	(0.0630 – 0.0650)
5	1.65 – 1.70	(0.0650 – 0.0669)

(e) Using snap ring pliers, install the snap ring.

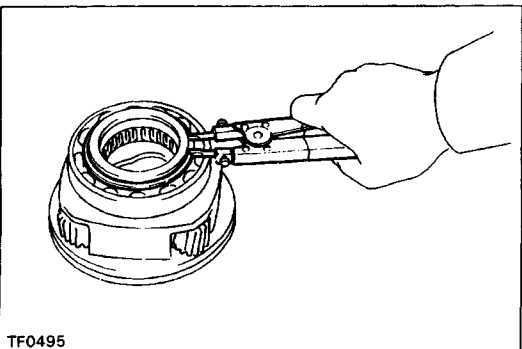

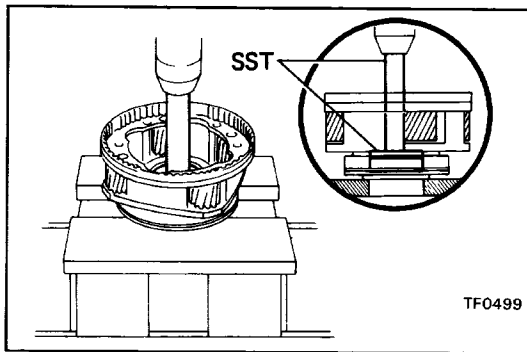

#### 4. IF NECESSARY, REPLACE PLANETARY GEAR INNER BEARING

(a) Using SST and a press, remove the bearing.  
SST 09550-10012 (09252-10010, 09557-10010)

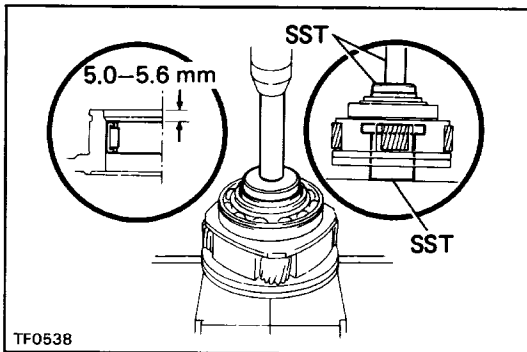

(b) Using SST and a press, install a new bearing.  
SST 09550-10012 (09252-10010, 09557-10010)  
and 09515-30010

**Bearing depth: 5.0 – 5.6 mm (0.197 – 0.220 in.)**





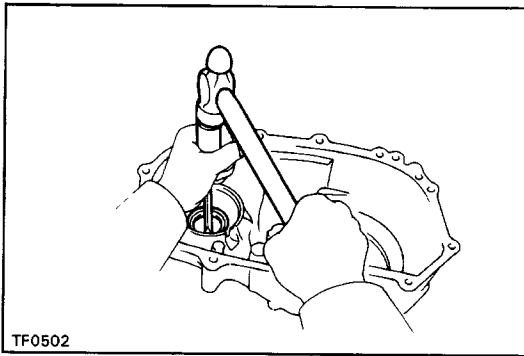

## 2. IF NECESSARY, REPLACE FRONT CASE OIL SEAL

(a) Using a screwdriver and hammer, drive out the oil seal.

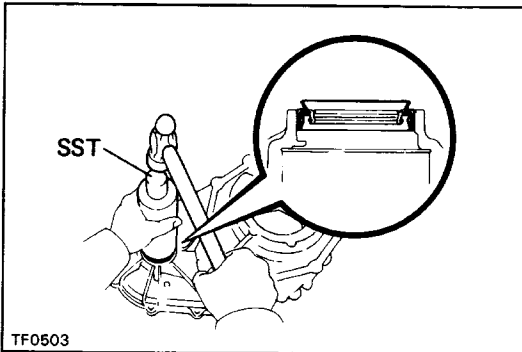

(b) Using SST and a hammer, drive in a new oil seal until its surface is flush with the case upper surface.

SST 09316-60010 (09316-00010)

(c) Coat the lip of the oil seal with MP grease.

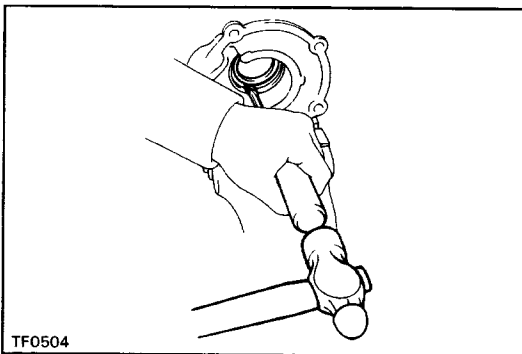

## 3. IF NECESSARY, REPLACE EXTENSION HOUSING OIL SEAL

(a) Using a screwdriver and hammer, drive out the oil seal.

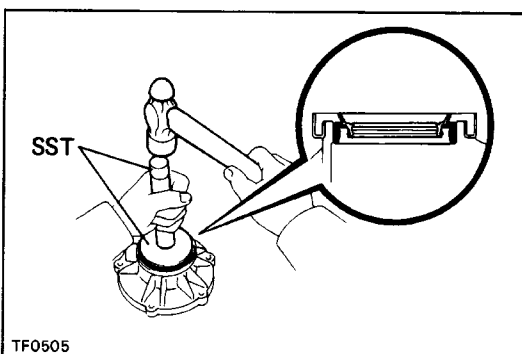

(b) Using SST and a hammer, drive in a new oil seal until its surface is flush with the housing upper surface.

SST 09550-22011 (09550-00020, 09550-00031)

(c) Coat the lip of the oil seal with MP grease.

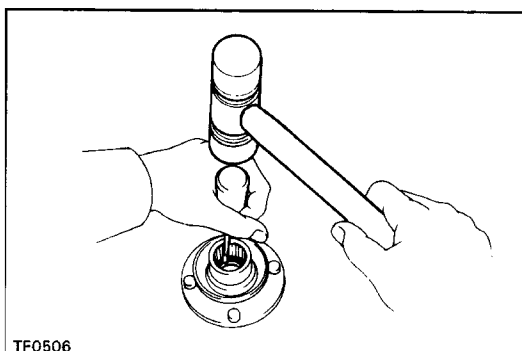

## 4. IF NECESSARY, REPLACE FRONT AND REAR COMPANION FLANGES OIL SEAL

(a) Using a screwdriver and hammer, drive out the oil seal.

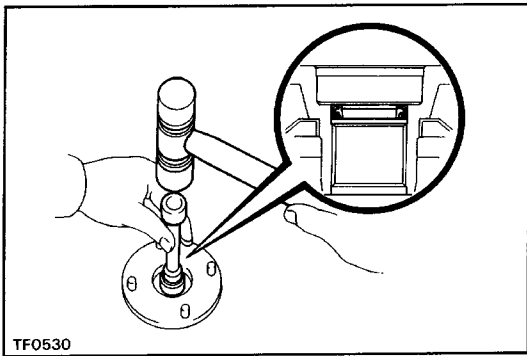

- (b) Using a socket wrench and hammer, drive in a new oil seal.  
 (c) Coat the lip of the oil seal with MP grease.

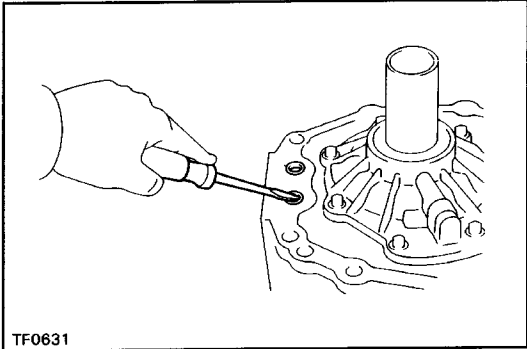

**5. (22R-E/G58, A340F)  
 IF NECESSARY, REPLACE SHIFT FORK SHAFT OIL SEALS**

- (a) Using a screwdriver, pry out the oil seal.

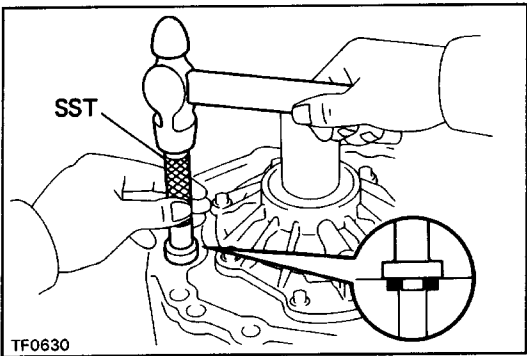

- (b) Using SST and a hammer, drive in a new oil seal.  
 SST 09304-12012  
**Oil seal depth: -0.5 - 0.5 mm**  
**(-0.0197 - 0.0197 in.)**

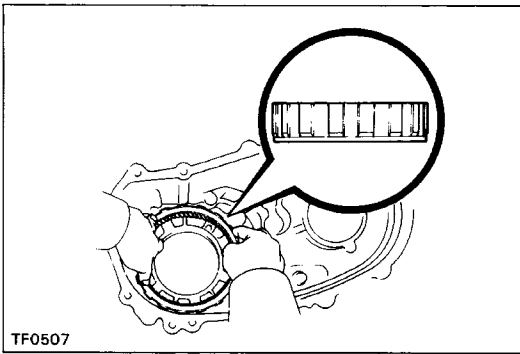

## ASSEMBLY OF TRANSFER

(See pages TF-32, 33)

### 1. INSTALL PLANETARY RING GEAR

(a) Install the planetary ring gear to the front case.

HINT: Make sure to install the ring gear in the correct direction.

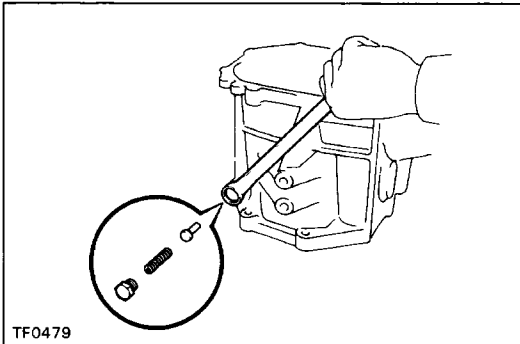

(b) Install the pin and spring.

(c) Apply liquid sealer to the plug.

**Sealant: Part No. 08833-00080, THREE BOND 1344, LOCTITE 242 or equivalent**

(d) Install and torque the plug.

**Torque: 19 N m (190 kgf -cm, 14 ft-lbf )**

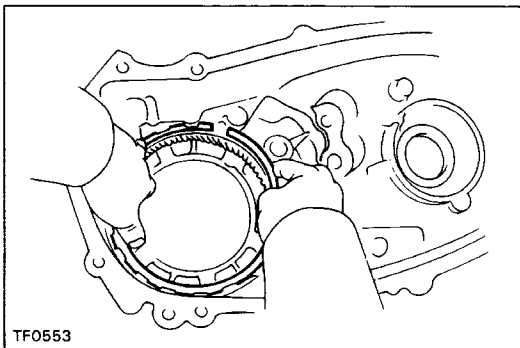

(e) Install the snap ring.

HINT: Be sure the end gap of the snap ring is not aligned with the upper side of the case.

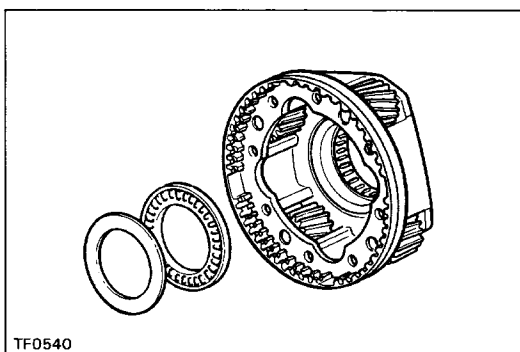

### 2. INSTALL INPUT SHAFT TO PLANETARY GEAR ASSEMBLY

(a) Apply gear oil to the thrust bearing and race.

(b) Install the race and thrust bearing.

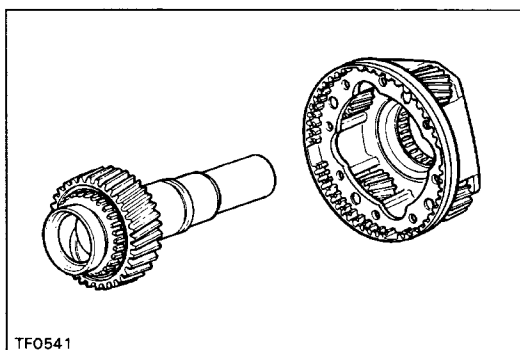

(c) Install the input shaft into the planetary gear assembly.

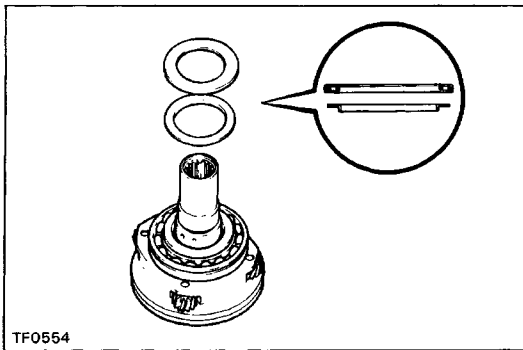

### 3. INSTALL THRUST BEARING AND INPUT SHAFT STOPPER

- (a) Apply gear oil to the thrust bearing and race.
- (b) Install the race and thrust bearing.

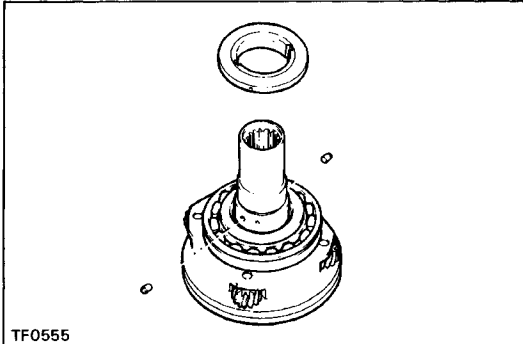

- (c) Install the two pins onto the input shaft.
- (d) Install the input shaft stopper.

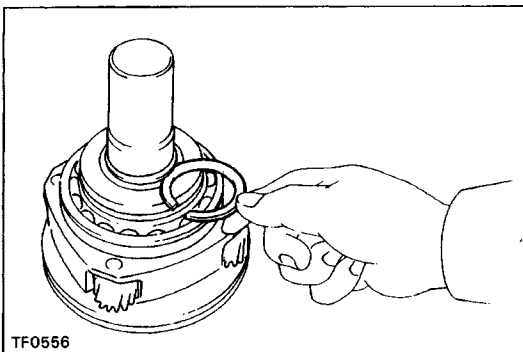

### 4. INSTALL SNAP RING

- (a) Select a snap ring that will allow 0.05 – 0.15 mm (0.0020 – 0.0059 in.) axial play.

Mark	Thickness mm (in.)	Mark	Thickness mm (in.)
A	2.10 – 2.15 (0.0827 – 0.0846)	L	2.60 – 2.65 (0.1024 – 0.1043)
B	2.15 – 2.20 (0.0846 – 0.0866)	M	2.65 – 2.70 (0.1043 – 0.1063)
C	2.20 – 2.25 (0.0866 – 0.0886)	N	2.70 – 2.75 (0.1063 – 0.1083)
D	2.25 – 2.30 (0.0886 – 0.0906)	P	2.75 – 2.80 (0.1083 – 0.1102)
E	2.30 – 2.35 (0.0906 – 0.0925)	Q	2.80 – 2.85 (0.1102 – 0.1122)
F	2.35 – 2.40 (0.0925 – 0.0945)	R	2.85 – 2.90 (0.1122 – 0.1142)
G	2.40 – 2.45 (0.0945 – 0.0965)	S	2.90 – 2.95 (0.1142 – 0.1161)
H	2.45 – 2.50 (0.0965 – 0.0984)	T	2.95 – 3.00 (0.1161 – 0.1181)
J	2.50 – 2.55 (0.0984 – 0.1004)	U	3.00 – 3.05 (0.1181 – 0.1201)
K	2.55 – 2.60 (0.1004 – 0.1024)		

- (b) Using snap ring pliers, install the snap ring.

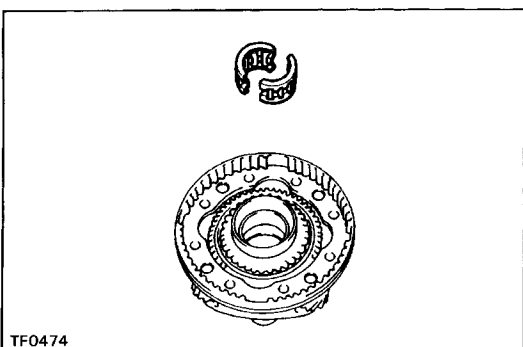
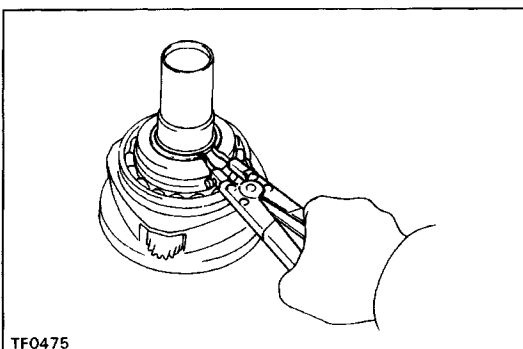

### 5. INSTALL NEEDLE ROLLER BEARING INTO INPUT SHAFT

- (a) Apply gear oil to the needle roller bearing.
- (b) Install the needle roller bearing into the input shaft.

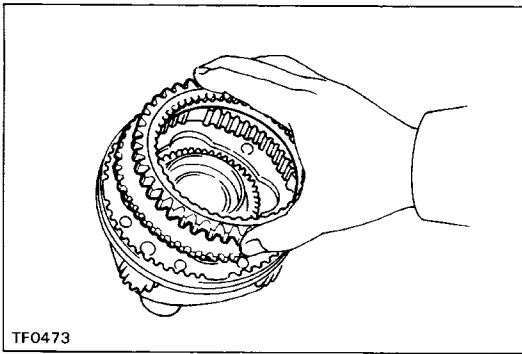

## 6. INSTALL LOW GEAR SPLINE PIECE

(a) Install the low gear spline piece to the planetary carrier.

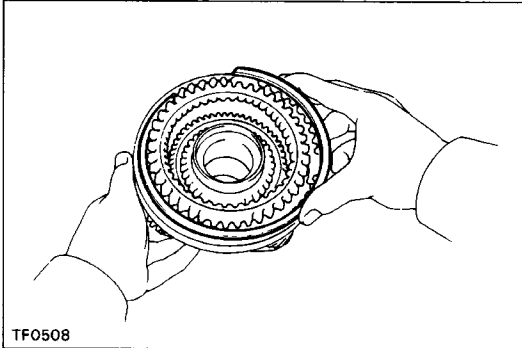

(b) Install the snap ring.

HINT: Be sure the end gap of the snap ring is not aligned with cutout portion of the planetary carrier.

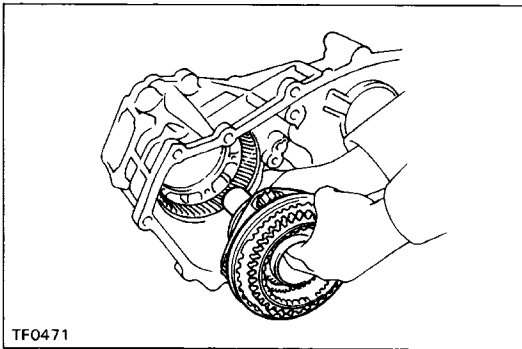

## 7. INSTALL PLANETARY GEAR ASSEMBLY TO FRONT CASE

(a) Install the planetary gear assembly with the input shaft.

HINT: If necessary, heat the front case to about 70°C (158°F).

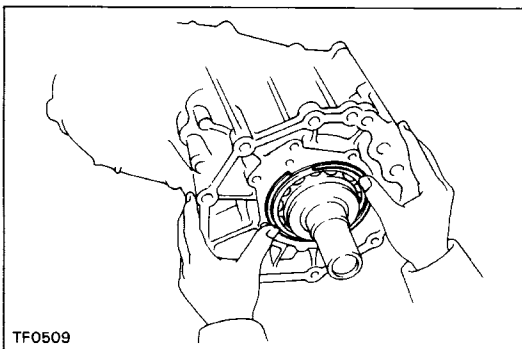

(b) Install the snap ring.

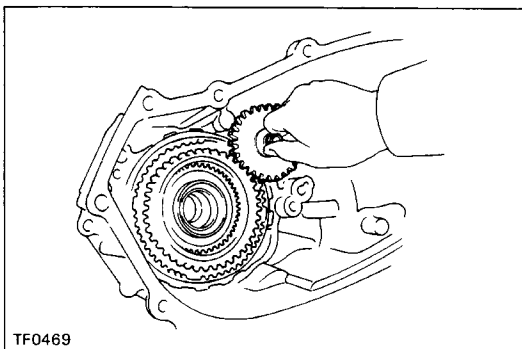

## 8. INSTALL OIL PUMP DRIVE GEAR

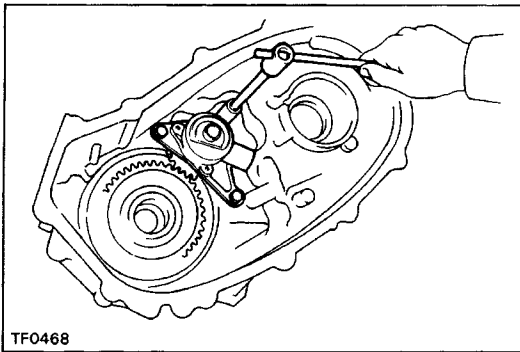
**9. INSTALL OIL PUMP BODY ASSEMBLY**

- (a) Install the oil pump body assembly.
- (b) Install and torque the three bolts.

**Torque: 11 N-m (115 kgf-cm, 8 ft-lbf)**

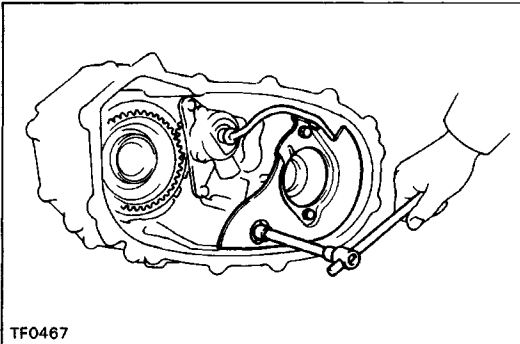
**10. INSTALL SEPARATER WITH OIL STRAINER**

- (a) Coat a new O-ring with gear oil and install it to the oil strainer pipe.
- (b) Install the separator with the oil strainer.
- (c) Install and torque the three bolts.

**Torque: 18 N-m (185 kgf-cm, 13 ft-lbf)**

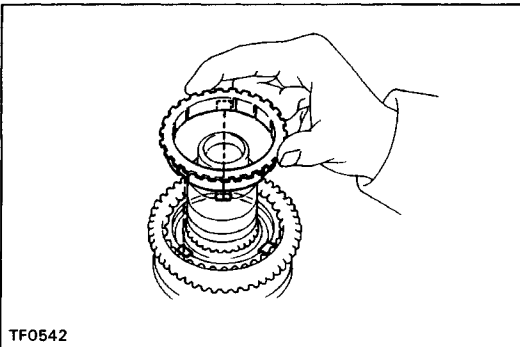
**11. INSTALL REAR OUTPUT SHAFT, DRIVEN SPROCKET AND CHAIN**

- (a) Apply MP grease to the synchronizer ring (R150F, G58).
- (b) Align the synchronizer ring slots with the shifting keys, and install it on the high and low clutch hub.

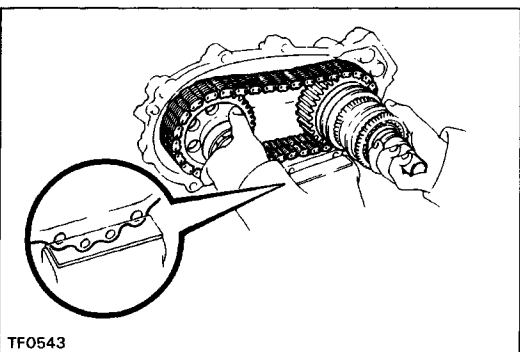

- (c) Assemble the rear output shaft, driven sprocket and chain.

- (d) Mount the rear case in the vise.

**NOTICE: Be careful not to damage the sealing surface.**

- (e) Using a plastic hammer, tap the rear case with pushing the rear output shaft and driven sprocket.

**HINT: If necessary, heat the rear case to about 70°C (158°F).**

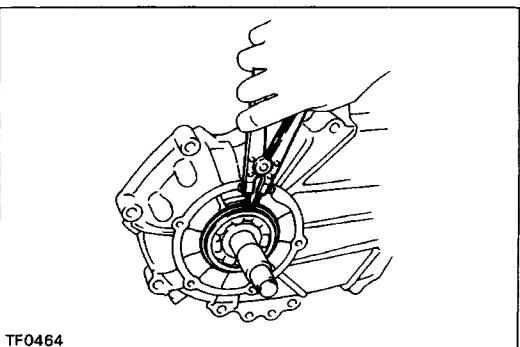

- (f) Using snap ring pliers, install the snap ring.

3VZ-E/R150F

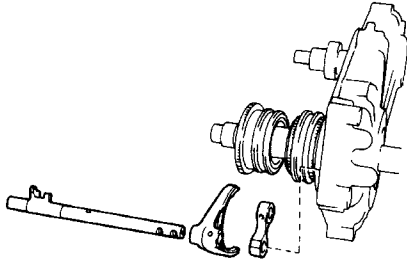

TF0463

## 12. INSTALL HIGH AND LOW FORK SHAFT, FORK AND STOPPER

(a) Place the high and low shift fork into the groove of the hub sleeve.

HINT: Make sure to install the shift fork in the correct direction.

(b) Install the fork shaft to the rear case through the shift fork and stopper.

22R-E/G58, A340F

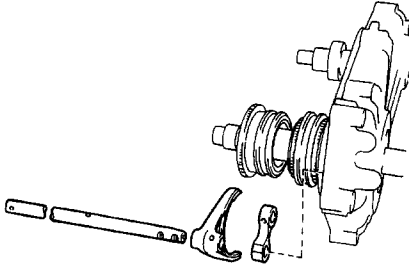

TF0616

## 13. INSTALL FRONT DRIVE FORK SHAFT, FORK AND SPRING

(a) Apply gear oil to the straight pin, and insert it into the case hole.

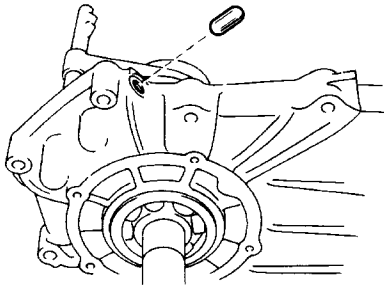

TF0462

(b) Place the front drive shift fork into the groove of the hub sleeve.

HINT: Make sure to install the shift fork in the correct direction.

(c) Install the spring to the fork shaft.

(d) Install the fork shaft to the rear case through the shift fork and stopper.

3VZ-E/R150F

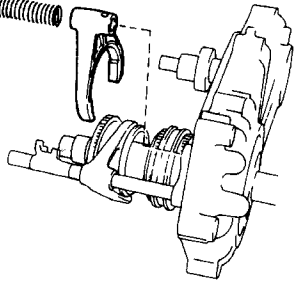

TF0461

22R-E/G58, A340F

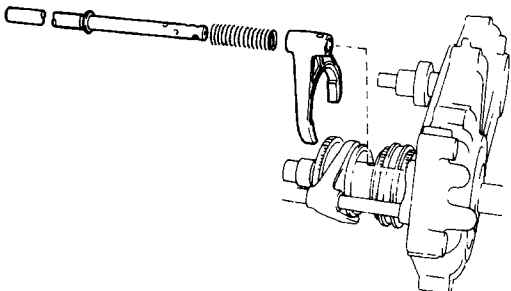

TF0623



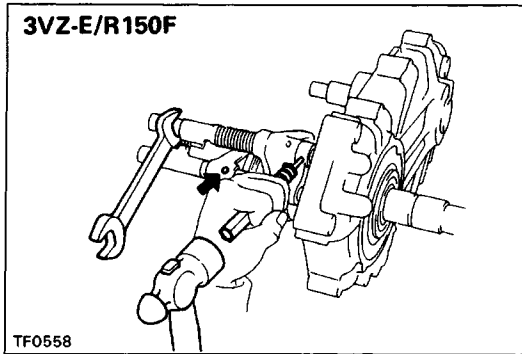

(e) Using a pin punch and hammer, drive in the two slotted spring pins.

HINT: When installing the pin in the front drive fork shaft, push the shaft towards the rear case and install the pin while the spring is compressed.

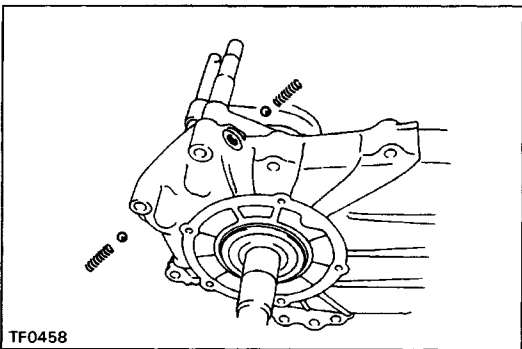
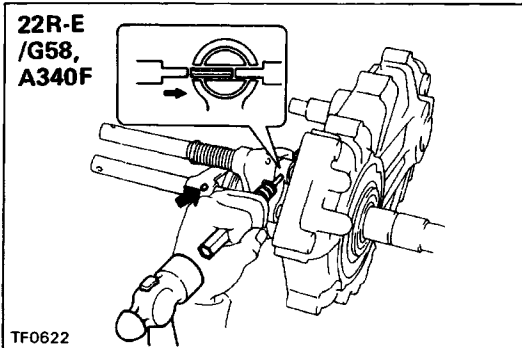

#### 14. INSTALL STRAIGHT SCREW PLUGS, SPRINGS AND LOCKING BALLS

(a) Install the ball and spring into the both holes.

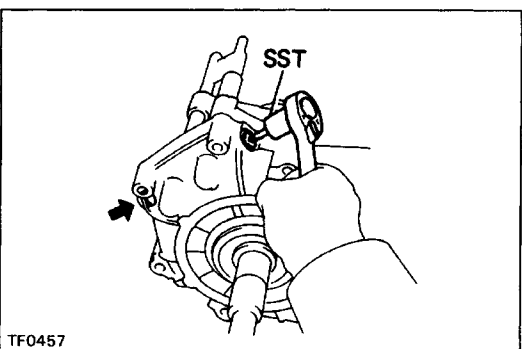

(b) Apply liquid sealer to the plugs.

**Sealant: Part No. 08833-00080, THREE BOND 1344, LOCTITE 242 or equivalent**

(c) Using SST, install and torque the two screws.

SST 09313-30021

**Torque: 19 N-m (190 kgf-cm, 14 ft-lbf)**

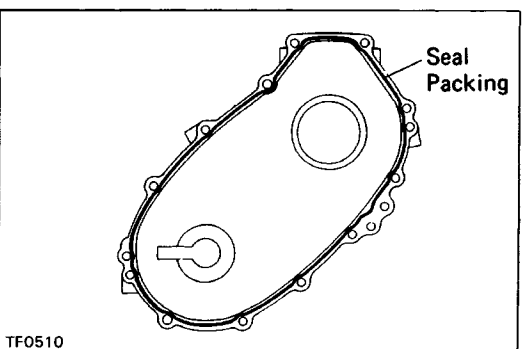

#### 15. ASSEMBLE FRONT CASE AND REAR CASE

(a) Apply seal packing to the rear case as shown in the figure.

**Seal packing: Part No. 08826-00090, THREE BOND 1281 or equivalent**

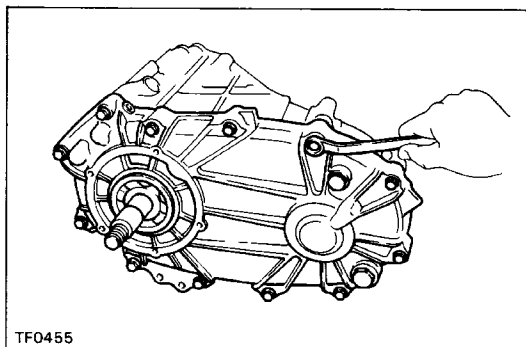

TF0455

(b) Shift the high and low hub sleeve to low side (rear side).

(c) Assemble the front case and rear case.

(d) Install and torque the twelve bolts.

**Torque: 37 N-m (380 kgf-cm, 27 ft-lbf)**

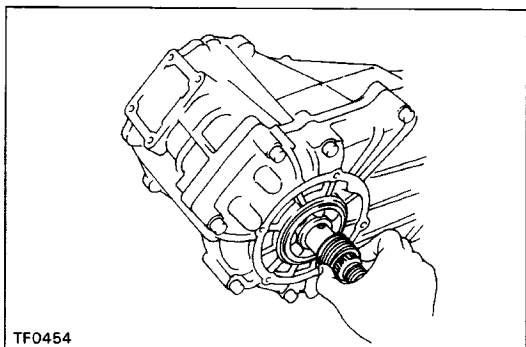

TF0454

#### 16. INSTALL SPEEDOMETER DRIVE GEAR

(a) Install the ball on the rear output shaft.

(b) Install the speedometer drive gear.

**HINT:** Make sure to install the speedometer drive gear in the correct direction.

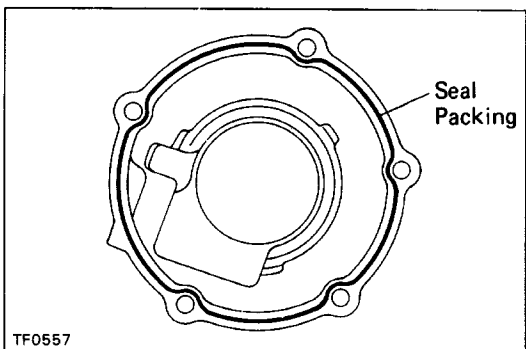

TF0557

#### 17. INSTALL EXTENSION HOUSING

(a) Apply seal packing to the extension housing as shown in the figure.

**Seal packing: Part No. 08826-00090, THREE BOND 1281 or equivalent**

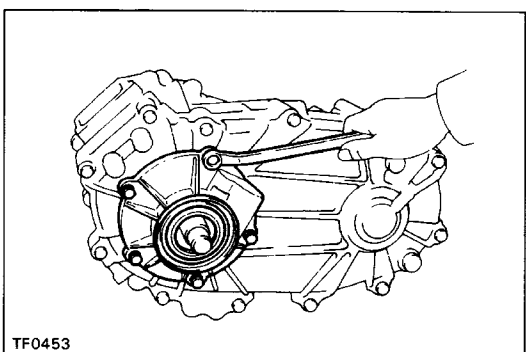

TF0453

(b) Install the extension housing to the rear case.

(c) Apply liquid sealer to the bolts.

**Sealant: Part No. 08833-00080, THREE BOND 1344, LOCTITE 242 or equivalent**

(d) Install and torque the five bolts.

**Torque: 11 N-m (115 kgf-cm, 8 ft-lbf )**

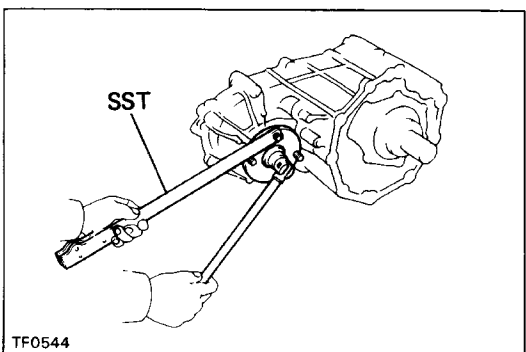

TF0544

#### 18. INSTALL FRONT COMPANION FLANGE

**HINT:** Front companion flange bolts are silver.

(a) Apply gear oil to the companion flange inner surface.

(b) Install the front companion flange to the driven sprocket shaft.

(c) Using SST to hold the flange, install the companion flange lock nut.

**SST 09330-00021**

**Torque: 118 N-m (1,200 kgf-cm, 87 ft-lbf)**

(d) Stake the lock nut.

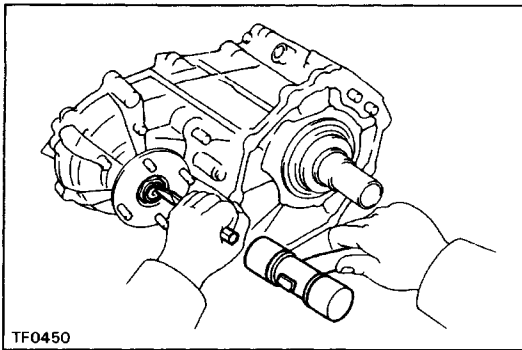
**19. INSTALL REAR COMPANION FLANGE**

**HINT:** Rear companion flange bolts are black.  
Install the rear companion flange in the same way as the front companion flange.

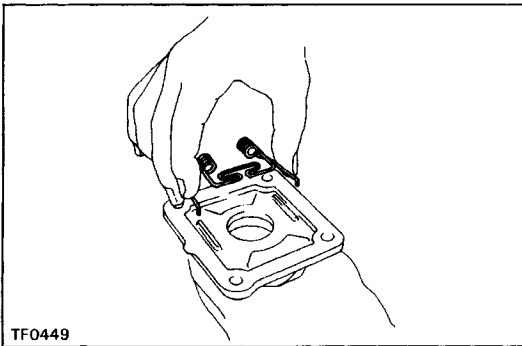
**20.-1 (3VZ-E/R 150F)****INSTALL CONTROL RETAINER**

(a) Install the select return spring to the control retainer.

(b) Remove the gasket and install a new one to the control retainer.

(c) Install the control retainer.

(d) Install and torque the four bolts.

**Torque: 18 N-m (185 kgf-cm, 13 ft-lbf)**

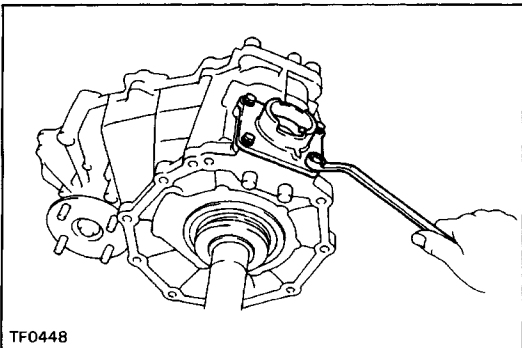
**20.-2 (22R-E/G58, A340F)****INSTALL UPPER COVER AND OIL DEFLECTOR**

(a) Remove the gasket and install a new one to the case cover.

(b) Install the upper cover and oil deflector.

(c) Install and torque the four bolts.

**Torque: 18 N-m (185 kgf-cm, 13 ft-lbf)**

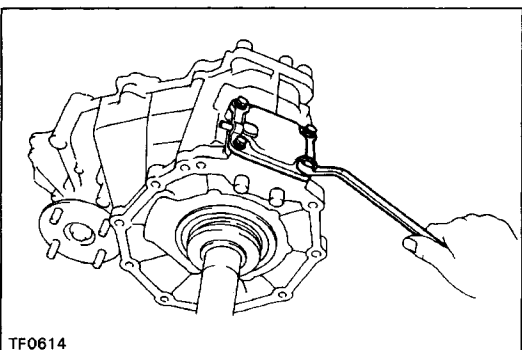
**21. INSTALL FRONT RETAINER**

(a) Remove the gasket and install a new one to the front retainer.

(b) Install the front retainer.

(c) Apply liquid sealer to the bolts.

**Sealant: Part No. 08833-00080, THREE BOND 1344,  
LOCTITE 242 or equivalent**

(d) Install and torque the seven bolts.

**Torque: 11 N m (115 kgf-cm, 8 ft-lbf)**

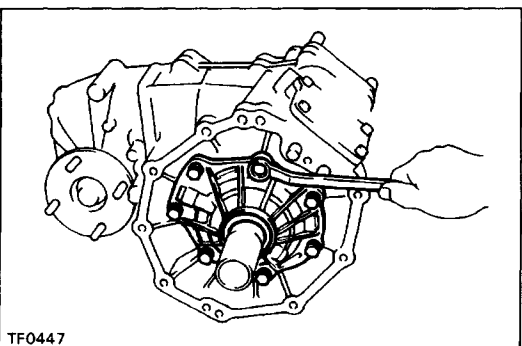

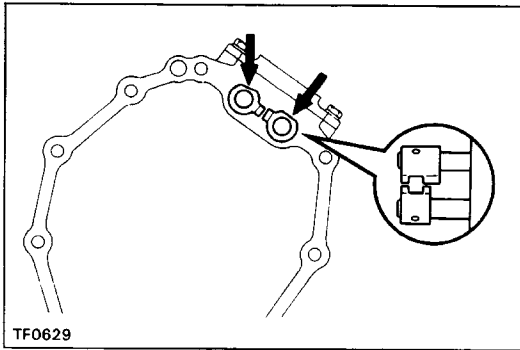
**22. (22R-E1G58, A340F)****INSTALL SHIFT GEAR HEAD NO. 1 AND NO.2**

- (a) Install two shift gear heads.
- (b) Using a pin punch and hammer, drive in the two slotted spring pins.

**23. CHECK FOLLOWING ITEMS:**

- (a) Check to see that the input shaft and output shafts rotate smoothly.
- (b) Check to see that shifting can be made smoothly to all positions.

**24. INSTALL TRANSFER INDICATOR SWITCH**

**Torque: 37 N-m (380 kgf-cm, 27 ft-lbf)**

**25. INSTALL NO. 1 SPEED SENSOR**

- (a) Install No.1 speed sensor.
- (b) Install and torque the bolt.

**Torque: 11 N-m (115 kgf-cm, 8 ft-lbf)**

**26. (22R-E/ 340F)****INSTALL TRANSFER L4 AND NEUTRAL POSITION SWITCH**

**Torque: 37 N-m (380 kgf-cm, 27 ft-lbf)**

# PROPELLER SHAFT

# PRECAUTIONS

Be careful not to grip the propeller shaft tube too tightly in the vise as this will cause deformation.

# TROUBLESHOOTING

You will find the cause of trouble more easily by properly using the table shown below. In this table, the numbers indicate the priority of the probable cause of trouble. Check each part in the order shown. If necessary, repair or replace the part.

See Page	PR-7 PR-9	PR-8	PR-8	PR-8	PR-7 PR-9	PR-9	(G-58, R-150, R150F) MT-91 (W55, W56) MT-40
Parts Name	Sleeve yoke spline worn	Center bearing worn	Propeller shaft runout	Propeller shaft imbalance	Sleeve yoke spline stuck	Spider bearing worn or stuck	Transmission extension housing rear bushing worn
Trouble							
Noise	2	1				3	
Vibration			3	4	2		1

# PROPELLER SHAFT COMPONENTS

PRO20-01

[2WD]

2 - Joint Type

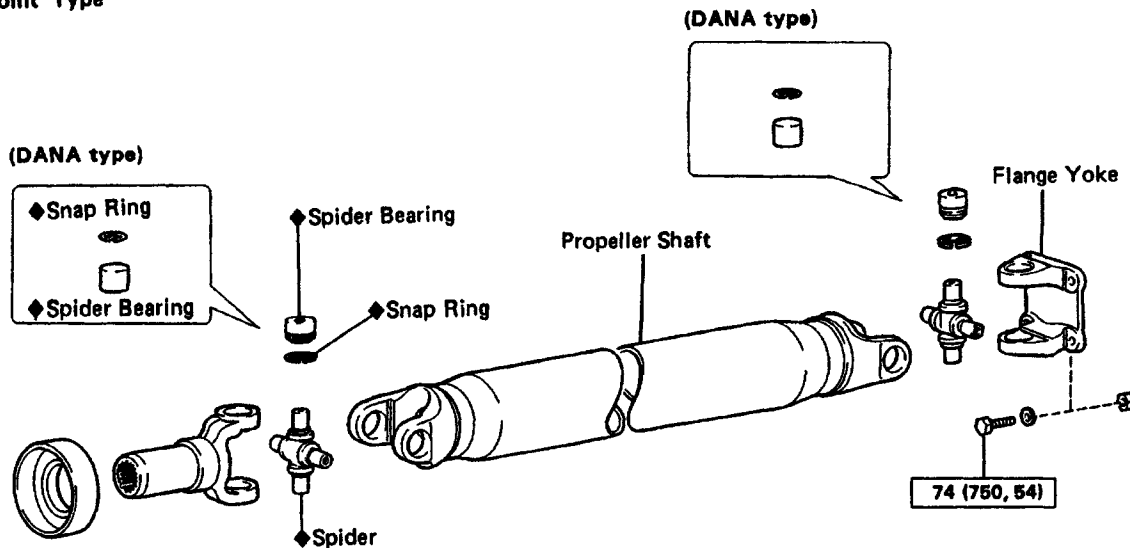

3 - Joint Type

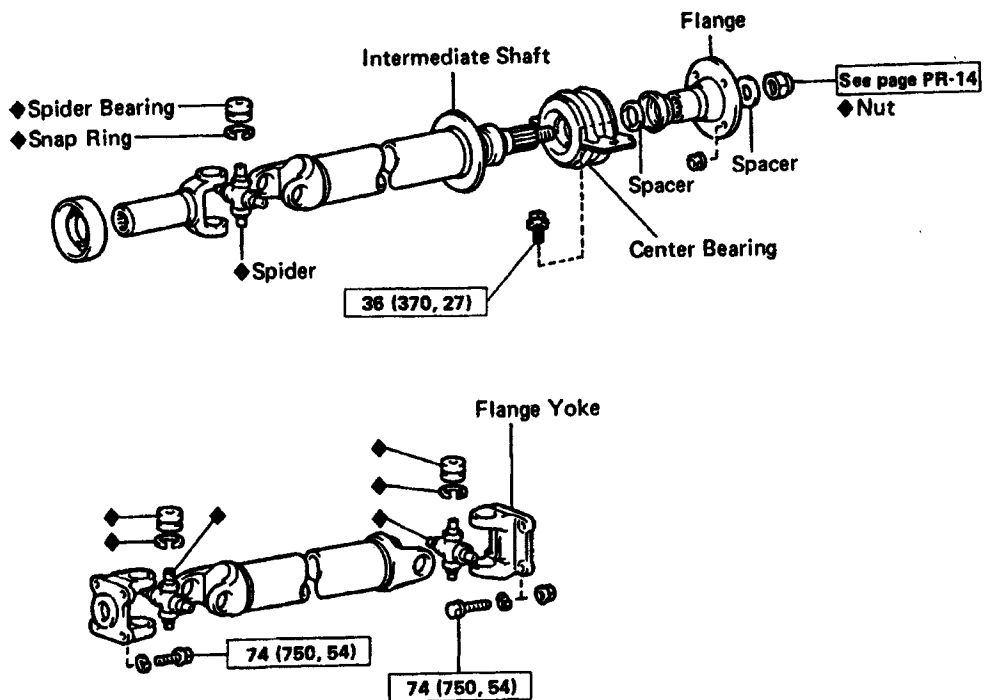

**N·m (kgf·cm, ft·lbf)** : Specified torque

◆ Non-reusable part

R05471  
PR0189

Z04237

[4WD]  
Front Propeller Shaft

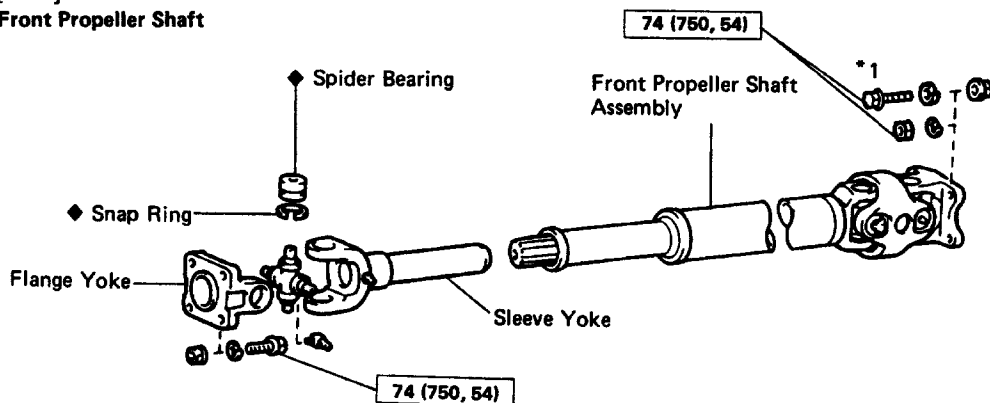

Rear Propeller Shaft  
2 - Joint Type

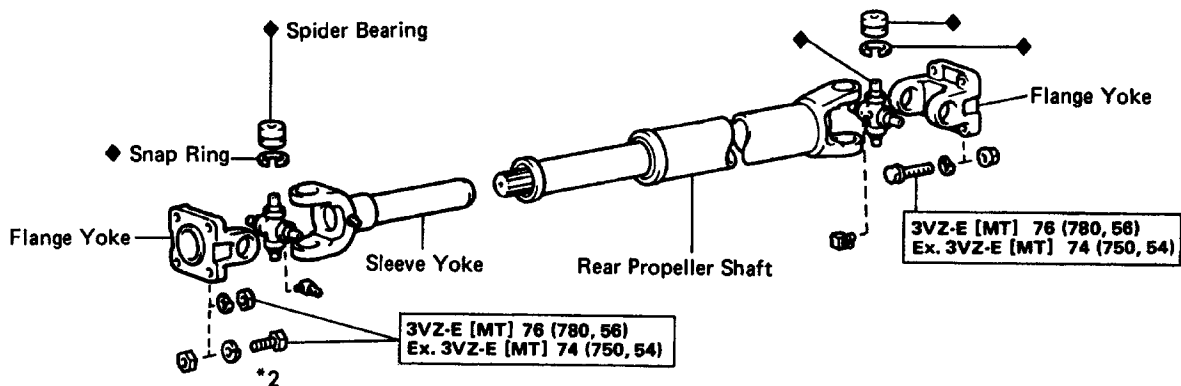

3 - Joint Type

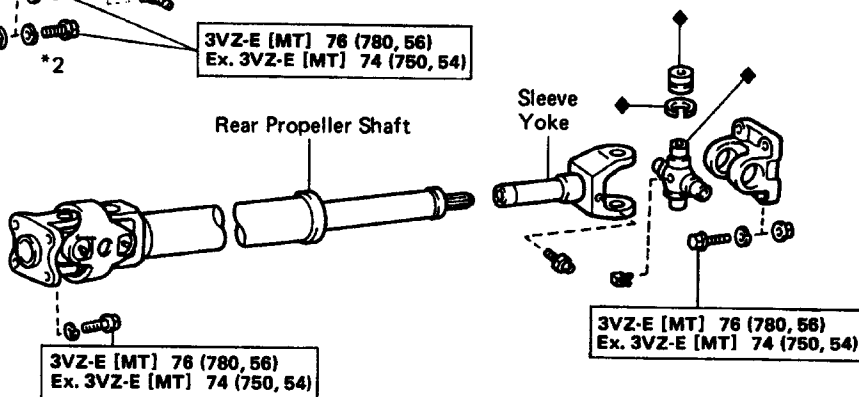
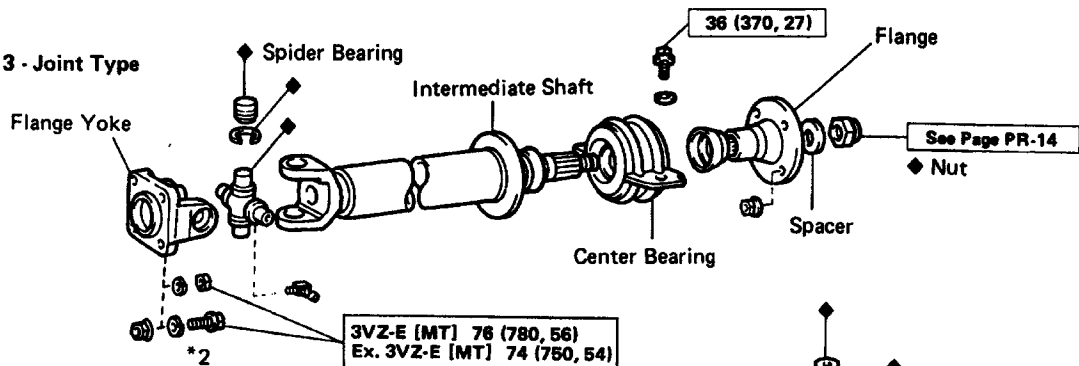

**N·m (kgf·cm, ft·lbf)** : Specified torque

◆ Non-reusable part

\*1: w/ RF1A Type Transfer  
\*2: w/ RF1A Type Transfer and A340H Automatic Transmission

PRO275  
PRO276  
PRO277



PR021-01

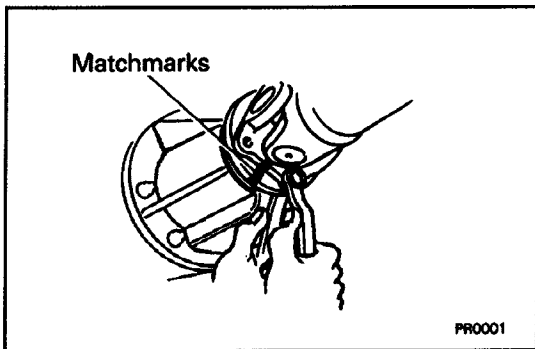

## PROPELLER SHAFT REMOVAL (2WD)

### 1. DISCONNECT PROPELLER SHAFT FLANGE FROM COMPANION FLANGE ON DIFFERENTIAL

- (a) Put matchmarks on the flanges.
- (b) Remove the four nuts.

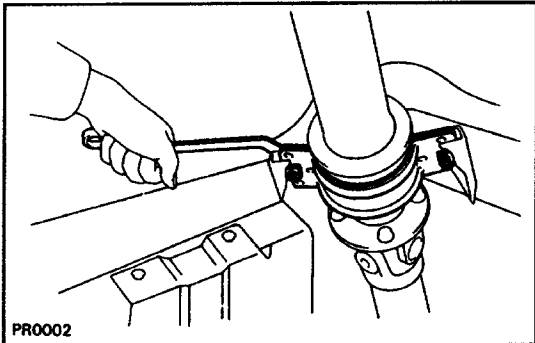

### 2. REMOVE CENTER SUPPORT BEARING FROM FRAME CROSSMEMBER (3-JOINT TYPE)

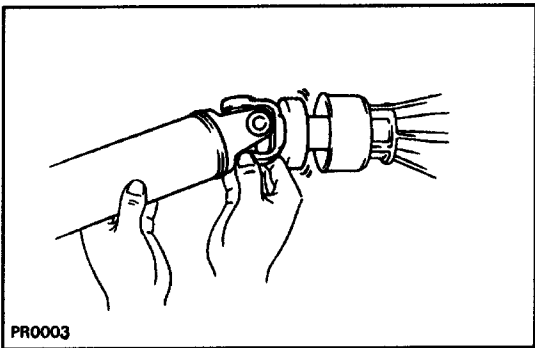

### 3. REMOVE PROPELLER SHAFT FROM TRANSMISSION

- (a) Pull the yoke from the transmission.

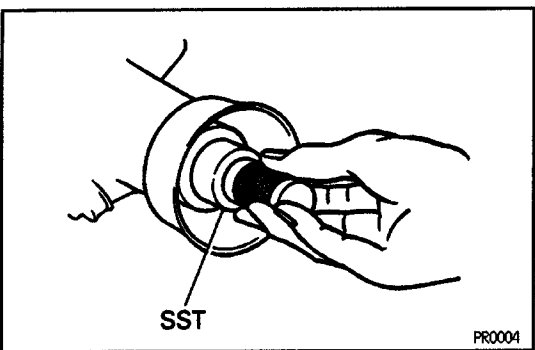

- (b) Insert SST in the transmission to prevent oil leakage.  
SST 09325-20010 (22R-E engine)  
09325-40010 (3VZ-E engine)

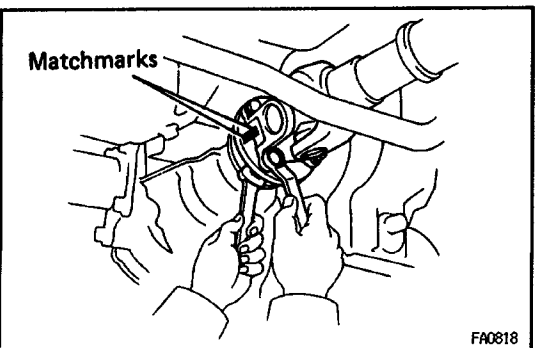

## PROPELLER SHAFT REMOVAL (4WD)

### 1. DISCONNECT PROPELLER SHAFT FLANGE FROM COMPANION FLANGE ON FRONT DIFFERENTIAL

- (a) Put matchmarks on the flanges.
- (b) Remove the four bolts and nuts.

PR022-01

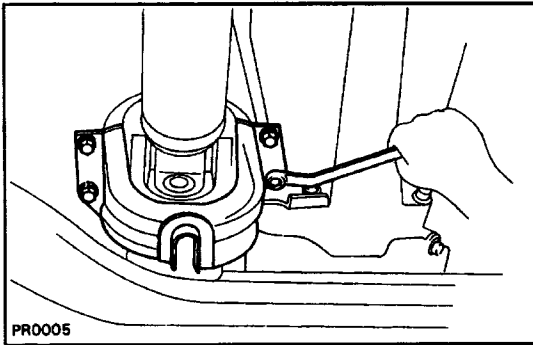

## 2. REMOVE FRONT PROPELLER SHAFT NO.2 DUST COVER

(W/RF1 A Type Transfer)

Remove the two bolts and two nuts and cover.

(w/VF1 A Type Transfer and A340H)

Remove the four bolts and cover.

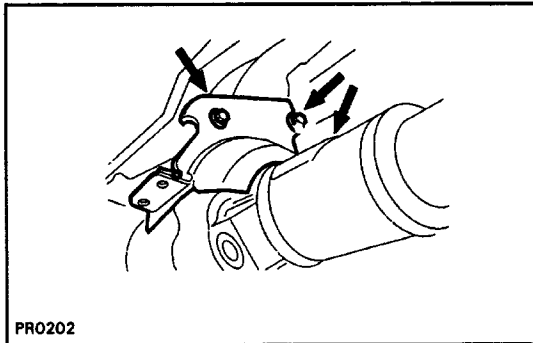

## 3. REMOVE FRONT PROPELLER SHAFT DUST COVER SUBASSEMBLY

(w/VF1 a Type Transfer and A340H)

Remove the three bolts and cover.

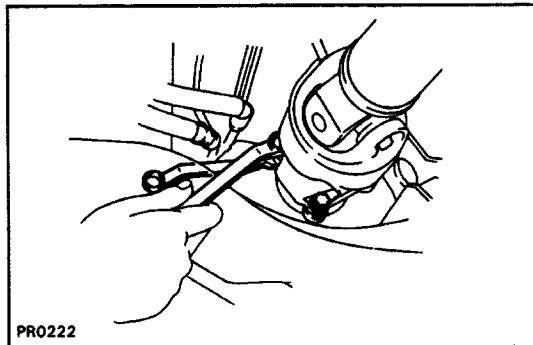

## 4. REMOVE FRONT PROPELLER SHAFT

(a) Suspend the front side of the propeller shaft.

(b) Put matchmarks on the flanges.

(c) Remove the four nuts or four bolts and nuts.

(d) Remove the front propeller shaft.

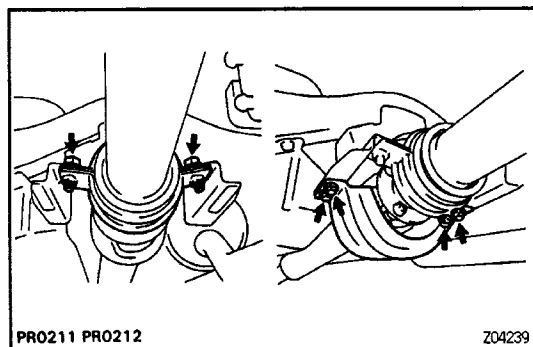

## 5. REMOVE CENTER SUPPORT BEARING FROM FRAME CROSSMEMBER (3-JOINT TYPE)

(a) Remove propeller shaft protector set bolts and propeller shaft protector.

(b) Remove center support bearing mount bolts.

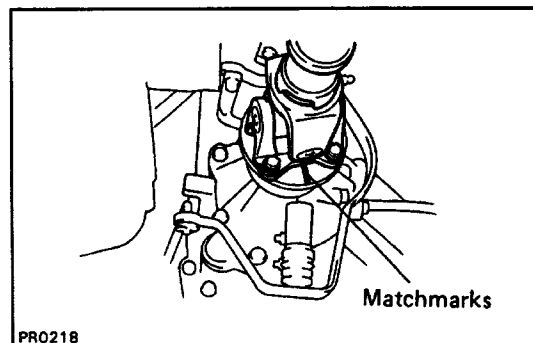

## 6. DISCONNECT PROPELLER SHAFT FLANGE FROM COMPANION FLANGE ON TRANSFER

(a) Put matchmarks on the flanges.

(b) Remove the four bolts and nuts or four nuts.

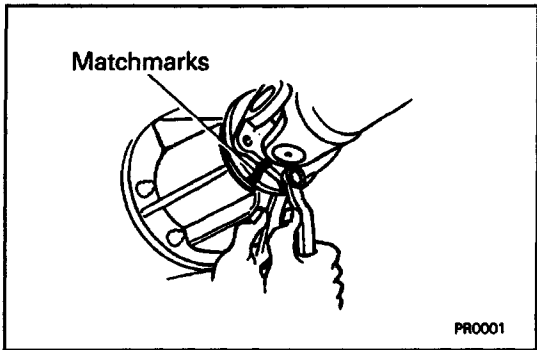

**7. REMOVE REAR PROPELLER SHAFT**

- (a) Put matchmarks on the flanges.
- (b) Remove the four nuts.
- (c) Remove the rear propeller shaft.

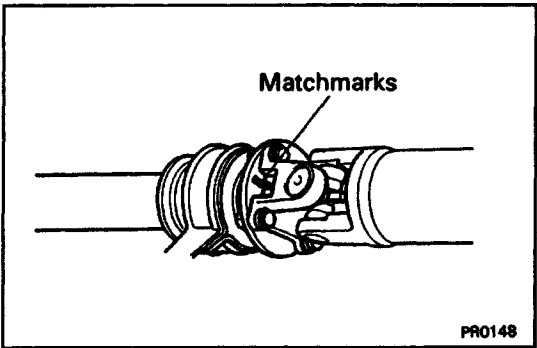

**PROPELLER SHAFT DISASSEMBLY**

PRO28-01

**1. SEPARATE PROPELLER SHAFT AND INTERMEDIATE SHAFT**

- (a) Put matchmarks on the flanges.
- (b) Remove the four bolts and nuts.

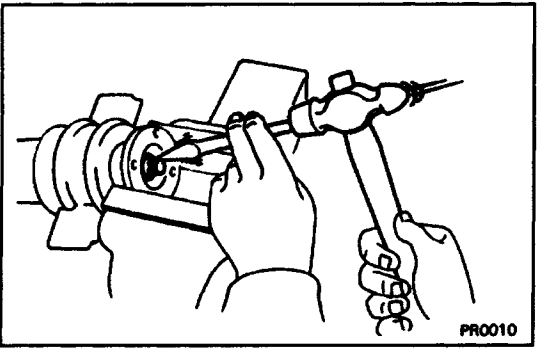

**2. REMOVE CENTER SUPPORT BEARING FROM INTERMEDIATE SHAFT**

- (a) Using a hammer and chisel, loosen the staked part of the nut.

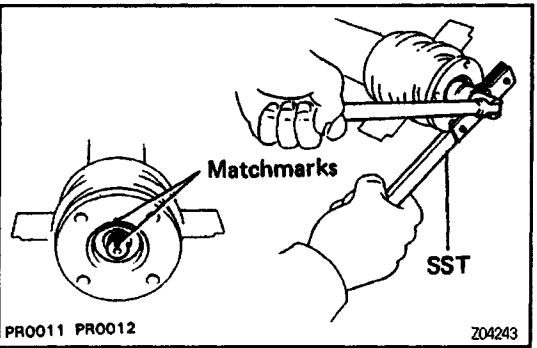

- (b) Using SST to hold the flange, remove the nut. SST 09930-00021
- (c) Put matchmarks on the flange and shaft.

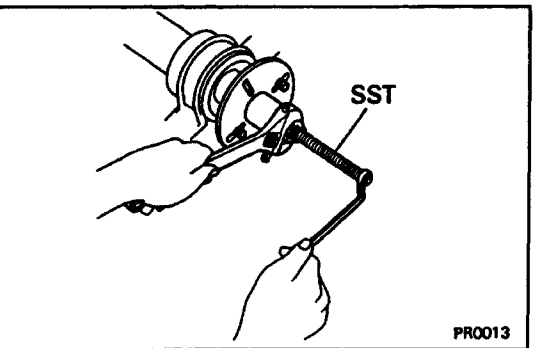

- (d) Using SST, remove the flange from the intermediate shaft. SST 09557-22022 (09557-22030)

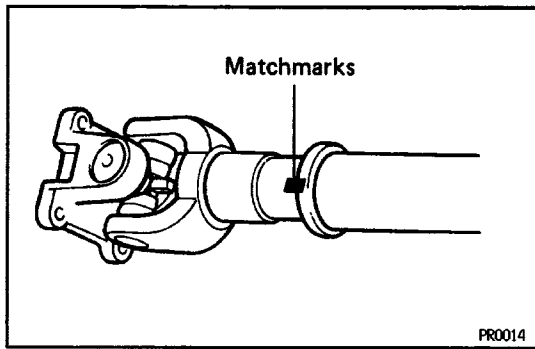

### 3. REMOVE SLEEVE YOKE FROM PROPELLER SHAFT (4WD)

- Place matchmarks on the sleeve yoke and shaft.
- Pull out the sleeve yoke from the shaft.

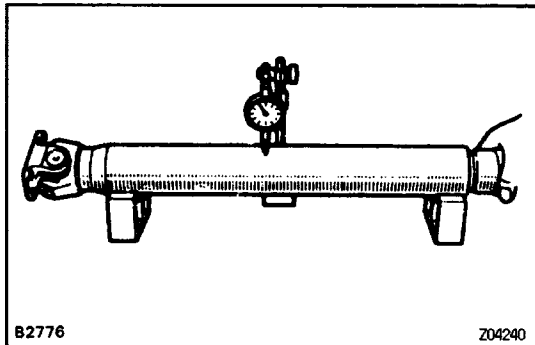

## PROPELLER SHAFT INSPECTION COMPONENTS

PR024-01

### 1. INSPECT PROPELLER AND INTERMEDIATE SHAFTS FOR DAMAGE OR RUNOUT

If shaft runout is greater than maximum, replace the shaft.

**Maximum runout:**

**0.8 mm (0.031 in.)**

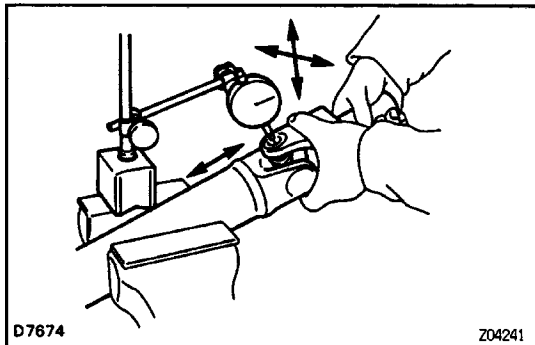

### 2. INSPECT SPIDER BEARINGS

- Inspect the spider bearings for wear or damage.
- Check the spider bearing axial play by turning the yoke while holding the shaft tightly.

**Bearing axial play:**

**w/o double cardan joint propeller shaft**

**Less than 0.05 mm (0.0020 in.)**

**If necessary, replace the spider bearing.**

**Bearing axial play:**

**w/ double cardan joint propeller shaft**

**Less than 0.05 mm (0.0020 in.)**

**If necessary, replace the propeller shaft.**

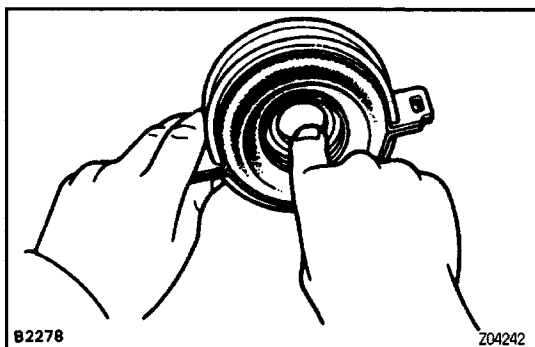

### 3. INSPECT CENTER SUPPORT BEARING FOR WEAR OR DAMAGE

Check that the bearing turns freely.

If the bearing is damaged, worn, or does not turn freely, replace it.

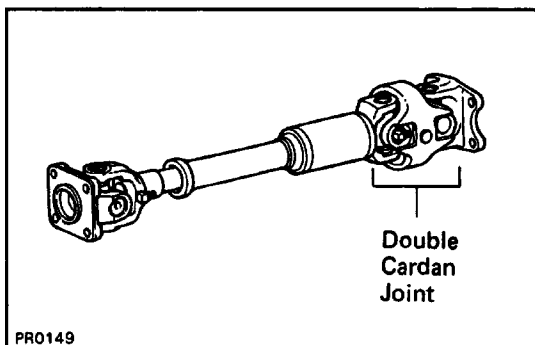

### 4. INSPECT WITH DOUBLE CARDAN JOINT PROPELLER SHAFT

- Inspect the shaft for wear or damage.
  - Inspect the double cardan joint for wear or damage.
- If any problem is found replace the propeller shaft assembly.

**HINT:** Front propeller shaft and 4WD three joint type rear propeller shafts.

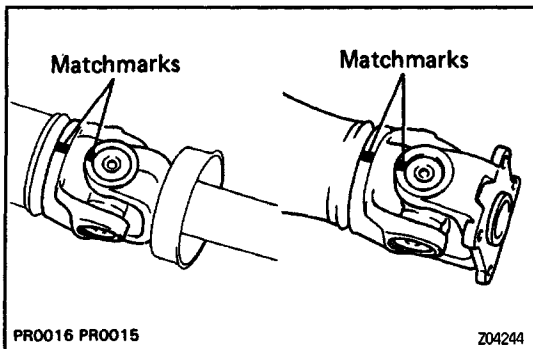

## SPIDER BEARING REPLACEMENT

### 1. PLACE MATCHMARKS ON SHAFT AND YOKE

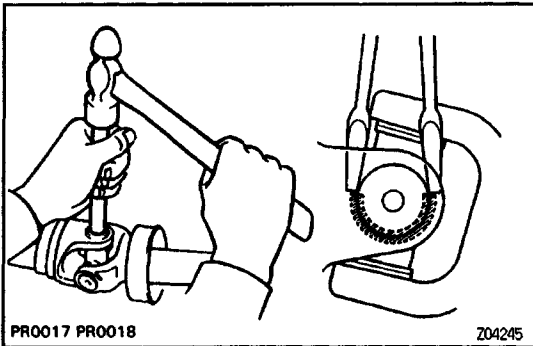

### 2. REMOVE SNAP RINGS

#### (TOYOTA type)

- (a) Slightly tap in the bearing outer races.
- (b) Using two screwdrivers, remove the four snap rings from the grooves.

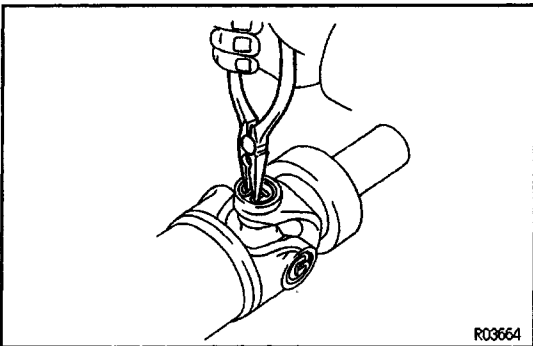

#### (DANA type)

- (a) Slightly tap in the bearing outer races.
- (b) Using snap ring pliers, remove the four snap rings from the grooves.

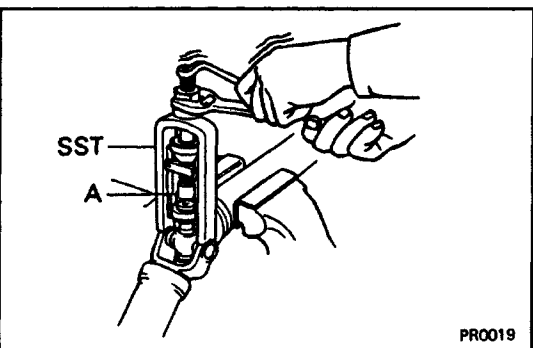

### 3. REMOVE SPIDER BEARINGS

- (a) Using SST, push out the bearing from the propeller shaft.

SST 09332-25010

HINT: Sufficiently raise the part indicated by A so that it does not come into contact with the bearing.

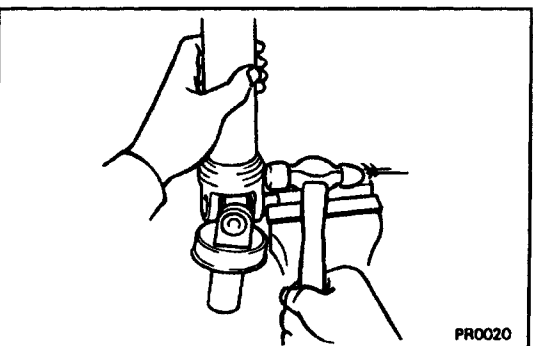

- (b) Clamp the bearing outer race in a vise and tap off the propeller shaft with a hammer.

HINT: Remove the bearing on opposite side in the same procedure.

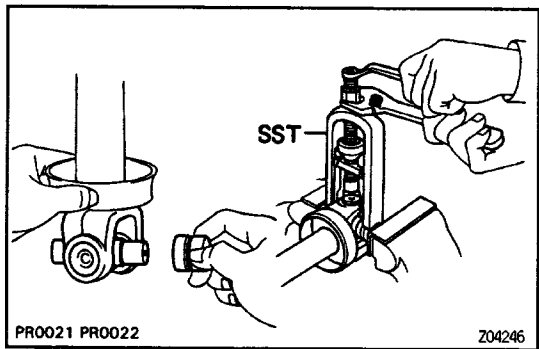

(c) Install the two removed bearing outer races to the spider.

(d) Using SST, push out the bearing from the yoke.  
SST 09332 - 25010

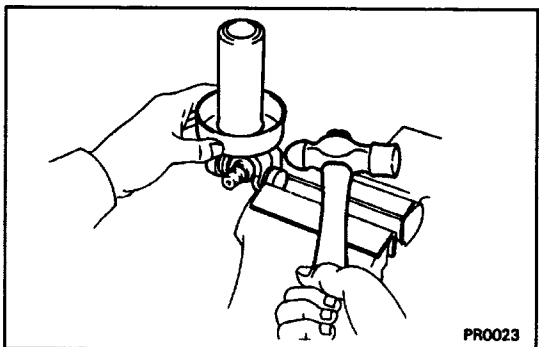

(e) Clamp the outer bearing race in a vise and tap off the yoke with a hammer.

HINT: Remove the bearing on the opposite side in the same procedure.

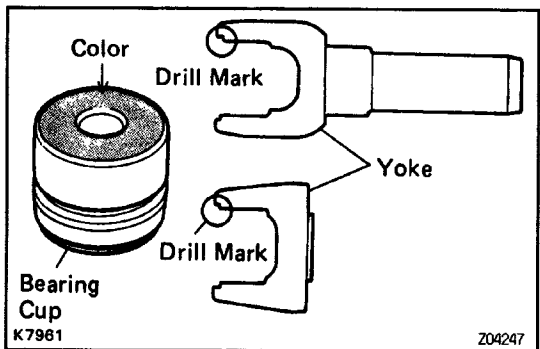

#### 4. SELECT THE SPIDER BEARING

Select the bearing according to whether or not there is a drill mark on the yoke section.

Yoke	Bearing
With drill mark	With color mark (Red)
No drill mark	No color mark

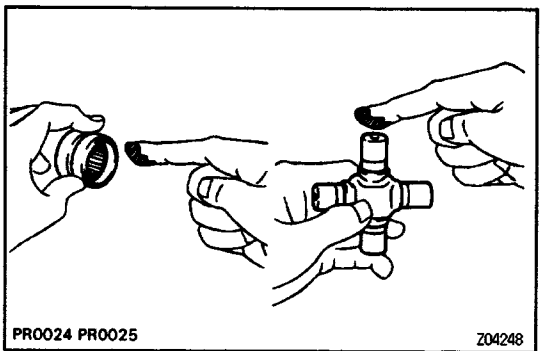

#### 5. INSTALL SPIDER BEARINGS

(a) Apply MP grease to the spider and bearings.

HINT: Be careful not to apply too much grease.

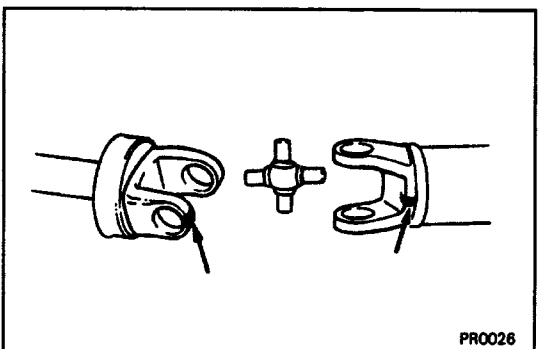

(b) Align the matchmarks on the yoke and shaft.

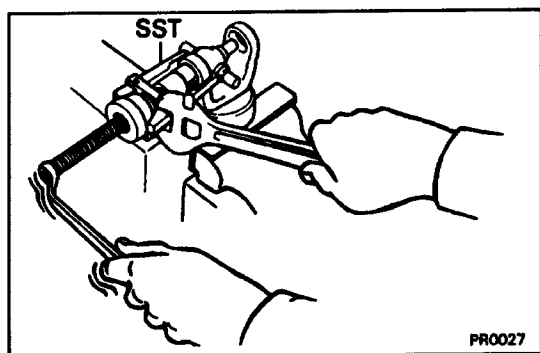

- (c) Fit the new spider into the yoke.  
 (d) Using SST, install the new bearings on the spider.  
 SST 09332-25010

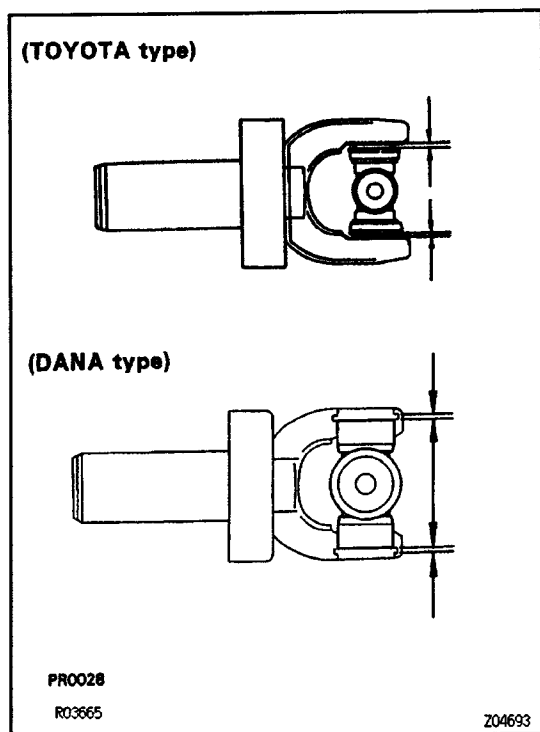

- (e) Using SST, adjust both bearings so that the snap ring grooves are at maximum and equal widths.

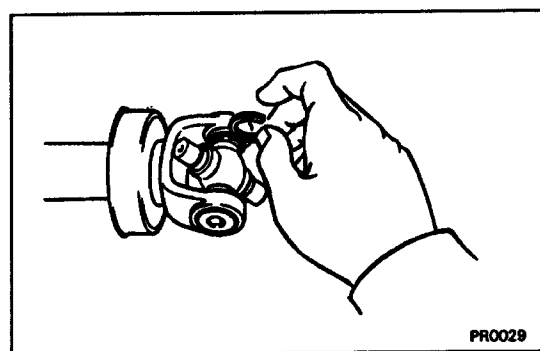

## 6. INSTALL SNAP RINGS

- (a) Install two snap rings of equal thickness which will allow 0-0.05 mm (0-0.0020 in.) axial play.

HINT: Do not reuse the snap rings.

(TOYOTA type)

Color	Mark	Thickness mm (in.)
-	1	2.100 - 2.150 (0.0827 - 0.0846)
-	2	2.150 - 2.200 (0.0846 - 0.0866)
-	3	2.200 - 2.250 (0.0866 - 0.0886)
Brown	-	2.250 - 2.300 (0.0886 - 0.0906)
Blue	-	2.300 - 2.350 (0.0906 - 0.0925)
-	6	2.350 - 2.400 (0.0925 - 0.0945)
-	7	2.400 - 2.450 (0.0945 - 0.0965)
-	8	2.450 - 2.500 (0.0965 - 0.0984)

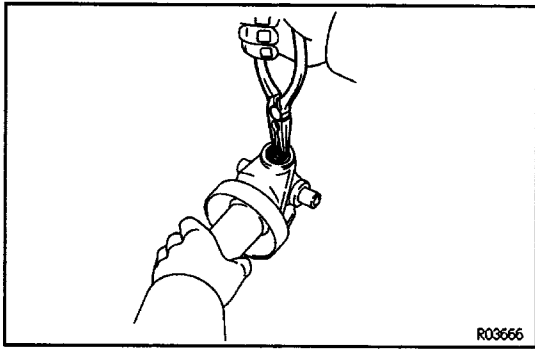
**(DANA type)**

Color	Thickness mm (in.)
Blue	<b>1.638 (0.0645)</b>
Yellow	<b>1.588 (0.0625)</b>
Silver	<b>1.537 (0.0605)</b>
Copper	<b>1.511 (0.0595)</b>
Black	<b>1.486 (0.0585)</b>
Red	<b>1.435 (0.0565)</b>
Green	<b>1.384 (0.0545)</b>

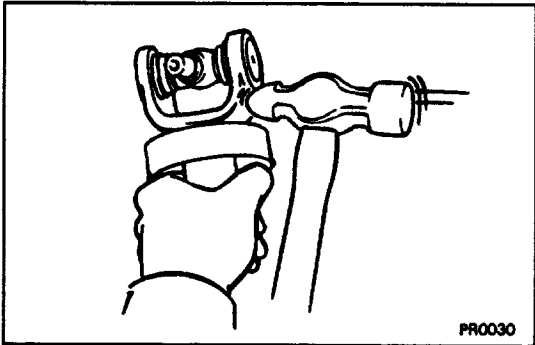

(b) Using a hammer, tap the yoke until there is no clearance between the bearing outer race and snap ring.

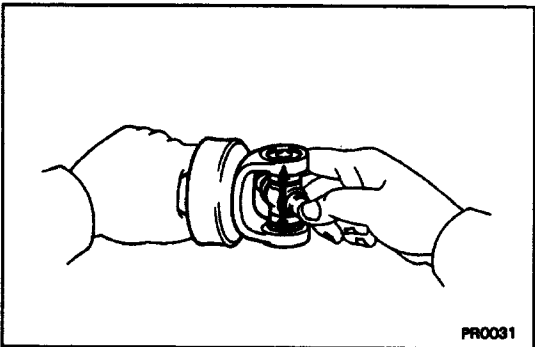
**7. CHECK SPIDER BEARING**

- (a) Check that the spider bearing moves smoothly.  
 (b) Check the spider bearing axial play.

**Bearing axial play:**

**Less than 0.05 mm (0.020 in.)**

HINT: Install new spider bearings on the shaft side in the procedure described above.



HINT: When replacing the rear propeller shaft spider on 4WD vehicles, be sure that the grease fitting assembly hole is facing in the direction shown in the figure.

**SPIDER GREASE FITTING ASSEMBLY DIRECTION FOR 4WD FRONT PROPELLER SHAFT**

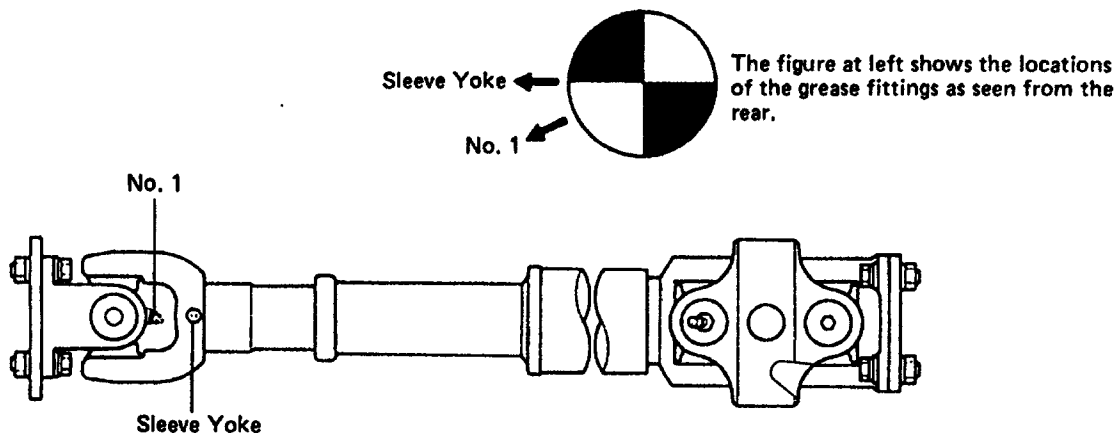

**SPIDER GREASE FITTING ASSEMBLY DIRECTION FOR 4WD REAR PROPELLER SHAFT (2-JOINT TYPE)**

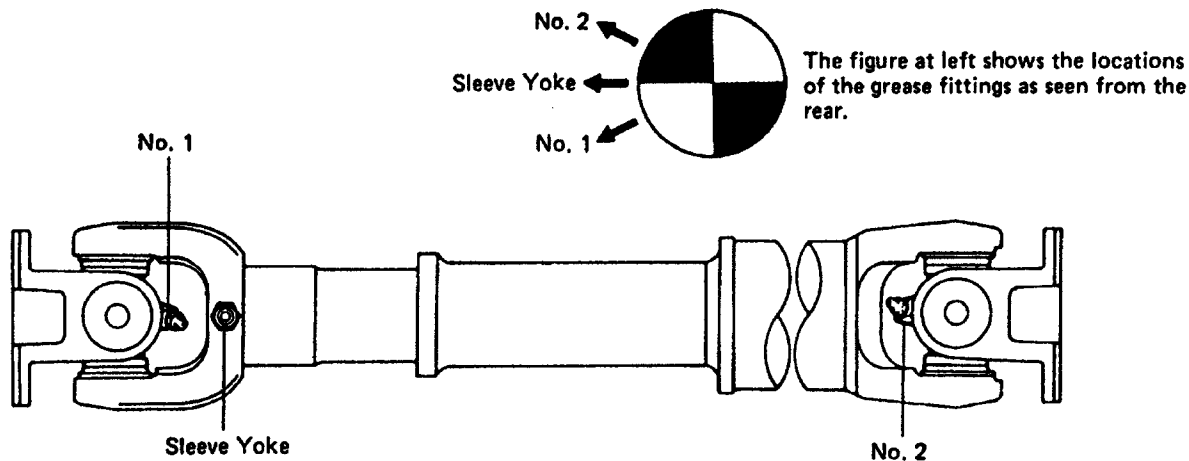

**SPIDER GREASE FITTING ASSEMBLY DIRECTION FOR 4WD REAR PROPELLER SHAFT (3-JOINT TYPE)**

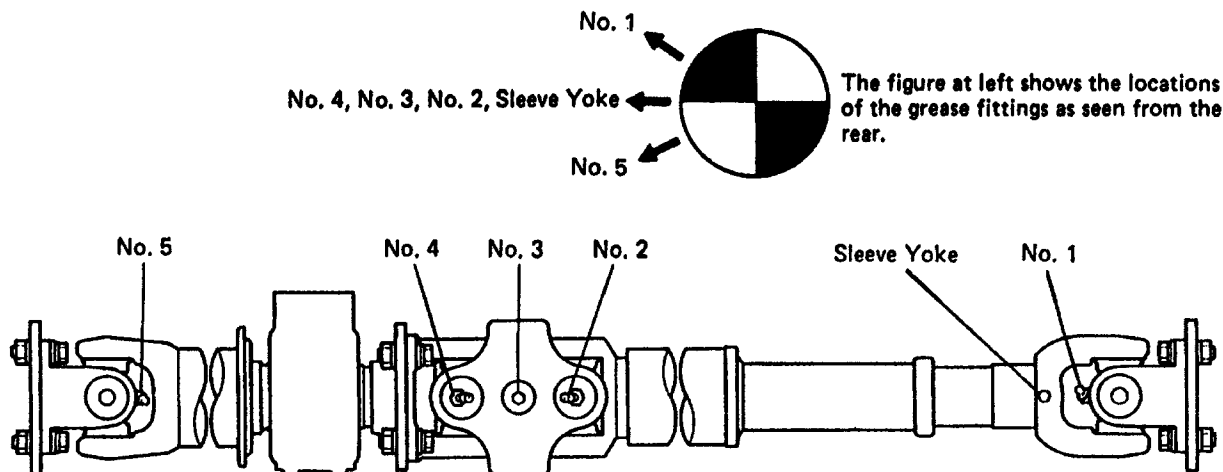

## PROPELLER SHAFT ASSEMBLY

HINT: When replacing the propeller shaft, install the new parts facing as shown in the illustration.

[2WD]  
3 - Joint Type

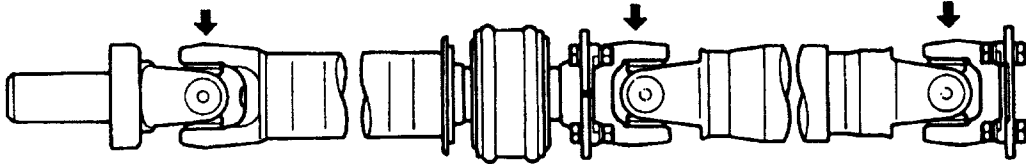

[4WD] Front

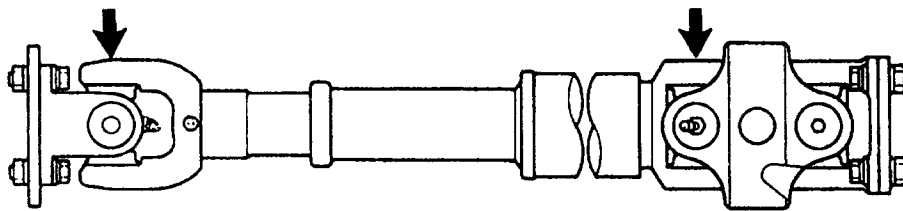

[4WD]  
2 - Joint Type (Rear)

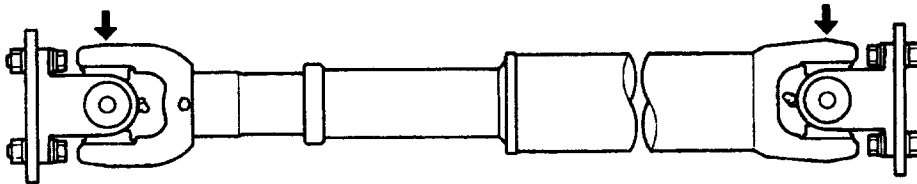

[4WD]  
3 - Joint Type (Rear)

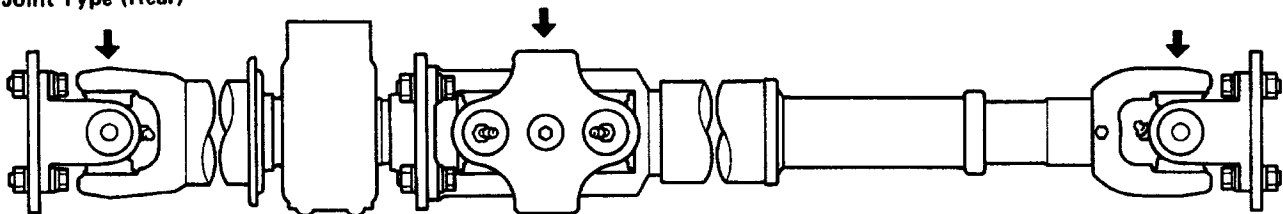

PR0155  
PR0218  
PR0187  
PR0183

204250

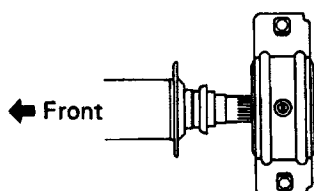

PR0036

### 1. INSTALL CENTER SUPPORT BEARING ON INTER-MEDIATE SHAFT

HINT: Install the center support bearing with the cutout toward the rear.

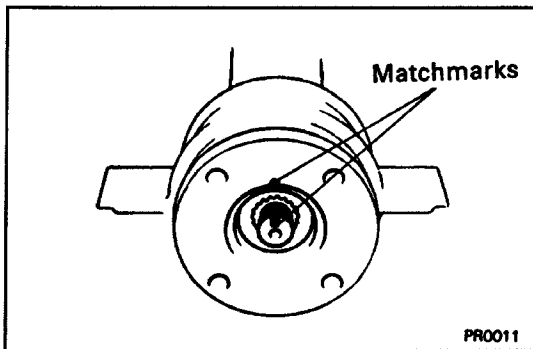

## 2. INSTALL FLANGE ON INTERMEDIATE SHAFT

- (a) Coat the splines of the intermediate shaft with MP grease.
- (b) Place the flange on the shaft and align the matchmarks.

HINT: If replacing either the center flange or intermediate shaft, reassemble them so that the front yoke of the intermediate shaft and the rear yoke of the propeller shaft are facing in the same direction.

- (c) Using SST to hold the flange, press the bearing into position by tightening down a new nut.

SST 09930-00021

**Torque: 181 N-m (1,850 kgf-cm, 134 ft-lbf)**

- (d) Loosen the nut.
- (e) Torque the nut again.

**Torque: 69 N-m (700 kgf-cm, 51 ft-lbf)**

- (f) Using a hammer and punch, stake the nut.

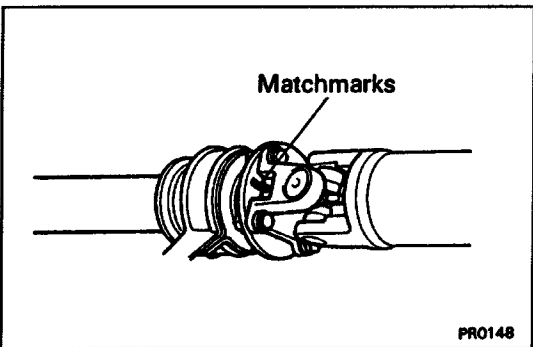
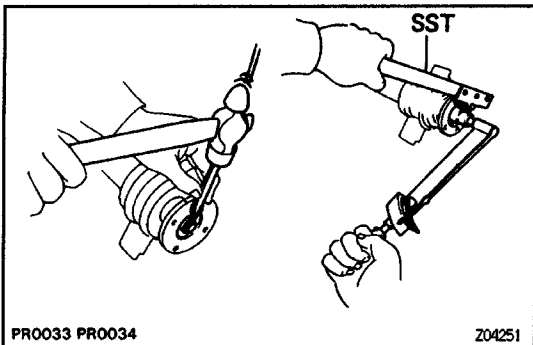

## 3. INSTALL PROPELLER SHAFT

- (a) Align the matchmarks on the flanges and connect the flanges with four bolts and nuts.

HINT: If replacing either the center flange or intermediate shaft, reassemble them so that the front yoke of the intermediate shaft and the rear yoke of the propeller shaft are facing in the same direction.

- (d) Torque the bolts and nuts.

**Torque:**

**4WD 3-joint Type 3VZ-E [MT]**

**76 N-m (780 kgf-cm, 56 ft-lbf)**

**Others**

**74 N-m (750 kgf-cm, 54 ft-lbf)**

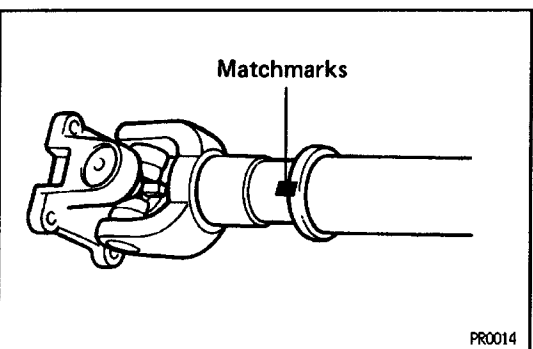

## 4. INSERT SLEEVE YOKE INTO PROPELLER SHAFT (4WD)

- (a) Apply Mp grease to the propeller shaft spline and sleeve yoke sliding surface.
- (b) Align the matchmarks on the yoke and propeller shaft.

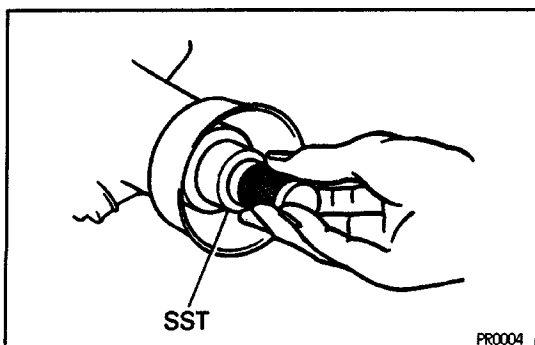

## PROPELLER SHAFT INSTALLATION (2WD)

### 1. INSERT YOKE IN TRANSMISSION

- (a) Remove SST.
- SST 09325-20010 or 09325-40010

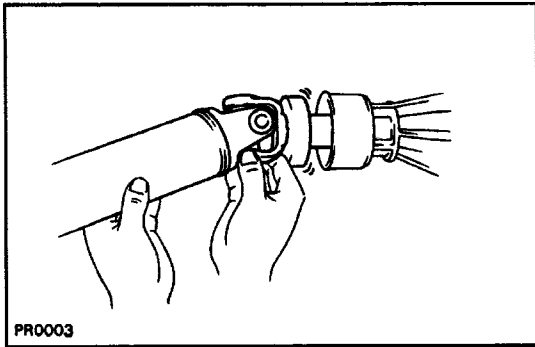

(b) Push the yoke into the transmission.

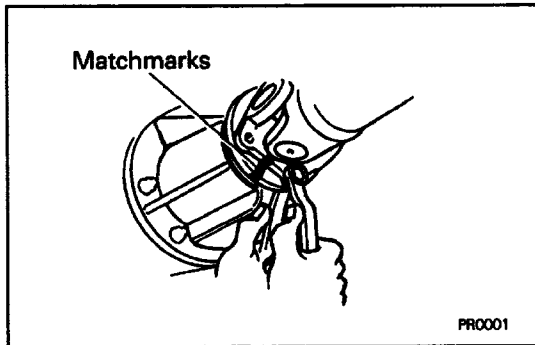

## 2. CONNECT PROPELLER SHAFT FLANGE TO COMPANION FLANGE ON DIFFERENTIAL

(a) Align the matchmarks on the flanges with four bolts and nuts.

(b) Torque the bolts and nuts.

**Torque:**

**4WD 3VZ-E [MT]**

**76 N-m (780 kgf-cm, 56 ft-lbf)**

**Ex. 4WD 3VZ-E [MT]**

**74 N-m (750 kgf-cm, 54 ft-lbf)**

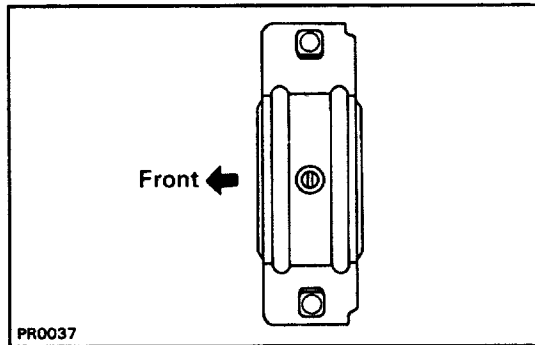

## 3. INSTALL CENTER SUPPORT BEARING TO FRAME CROSSMEMBER (3-JOINT TYPE)

(a) Install the center support bearing to the frame crossmember with two mount bolts finger tight.

(b) Check that the bearing bracket is at right angle to the propeller shaft. Adjust the bracket if necessary.

(c) Check that the center line of the center bearing is set to the center line of the bracket when the vehicle is in a no-load condition. Adjust the bracket if necessary.

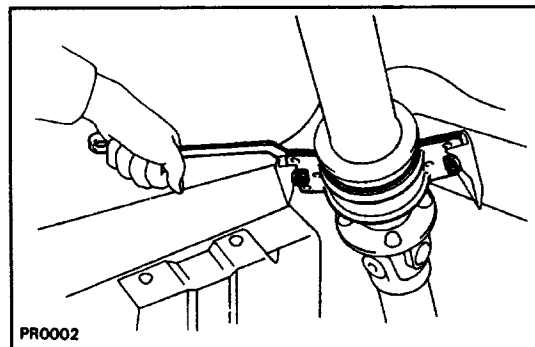

(d) Torque the mount bolts.

**Torque: 36 N-m (370 kgf-cm, 27 ft-lbf)**

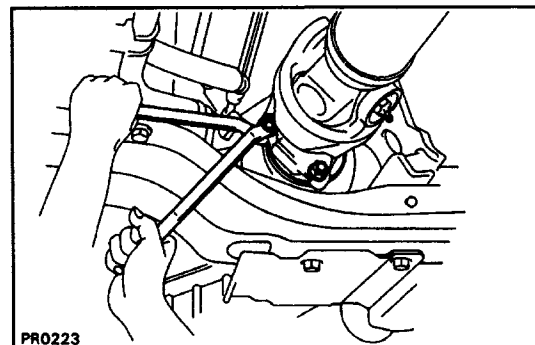

## PROPELLER SHAFT INSTALLATION (4WD)

### 1. CONNECT FRONT PROPELLER SHAFT FLANGE TO COMPANION FLANGE ON TRANSFER

(a) Align the matchmarks on the flanges and connect the flanges with four bolts and nuts.

(b) Torque the bolts and nuts.

**Torque: 41 N-m (750 kgf-cm, 54 ft-lbf)**

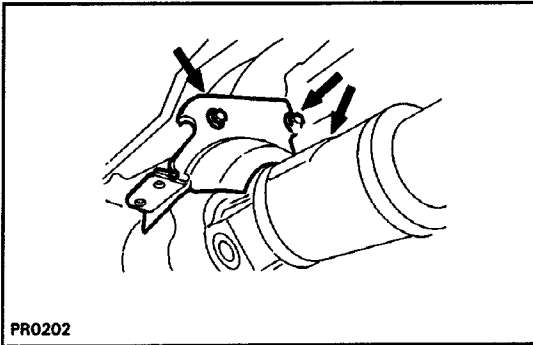

## 2. INSTALL FRONT PROPELLER SHAFT DUST COVER SUBASSEMBLY

(W/VF1 A Type Transfer and A340H)

- (a) Install the cover.
- (b) Install and torque the three bolts.

**Torque:**

**A bolts 36 N-m (370 kgf-cm, 27 ft-lbf)**

**B bolts 23 N-m (230 kgf-cm, 17 ft-lbf)**

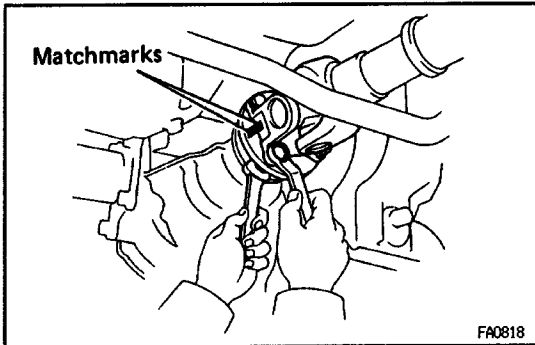

## 3. CONNECT PROPELLER SHAFT FLANGE TO COMPANION FLANGE ON FRONT DIFFERENTIAL

- (a) Align the matchmarks on the flanges and connect the flanges with four bolts and nuts.
- (b) Torque the bolts and nuts.

**Torque: 74 N-m (750 kgf-cm, 54 ft-lbf)**

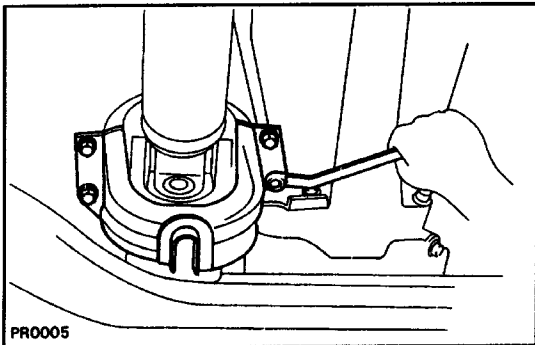

## 4. INSTALL FRONT PROPELLER SHAFT NO. 2 DUST COVER

- (a) Install the cover.
- (b) Install and torque the bolts and nuts.

**Torque:**

**Bolt 17 N-m (175 kgf-cm, 13 ft-lbf)**

**Nut 13 N-m (135 kgf-cm, 10 ft-lbf)**

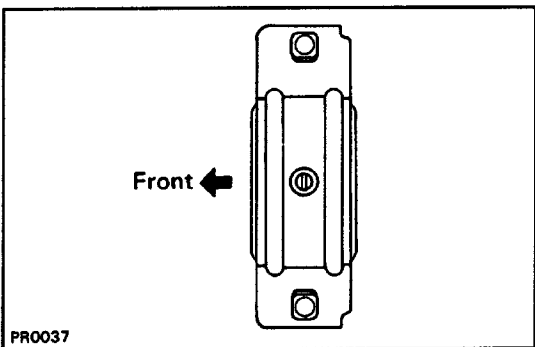

## 5. INSTALL CENTER SUPPORT BEARING TO FRAME CROSSMEMBER (3-JOINT TYPE)

- (a) Install the center support bearing to the frame crossmember with two mount bolts finger tight.
- (b) Check that the bearing bracket is at right angle to the propeller shaft. Adjust the the bracket if necessary.
- (c) Check that the center line of the center bearing is set to the center line of the bracket when the vehicle is in a no-load condition. Adjust the bracket if necessary.

- (d) Torque the mount bolts.

**Torque: 36 N-m (370 kgf-cm, 27 ft-lbf)**

- (e) Install propeller shaft protector and four set bolts.

- (f) Torque the set bolts.

**Torque: 29 N-m (300 kgf-cm, 22 ft-lbf)**

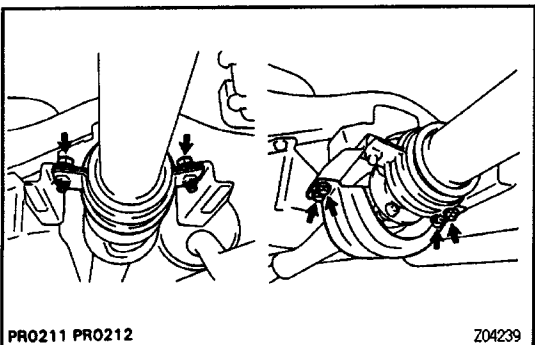

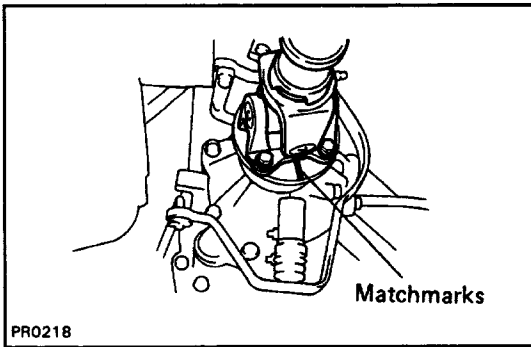

## 6. CONNECT REAR PROPELLER SHAFT FLANGE TO COMPANION FLANGE ON TRANSFER

- (a) Align the matchmarks on the flanges and connect the flanges with four bolts and nuts.
- (b) Torque the bolts and nuts.

### Torque:

**3VZ-E [MT]**

**76 N-m (780 kgf-cm, 56 ft-lbf)**

**Ex. 3VZ-E [MT]**

**74 N-m (760 kgf-cm, 54 ft-lbf)**

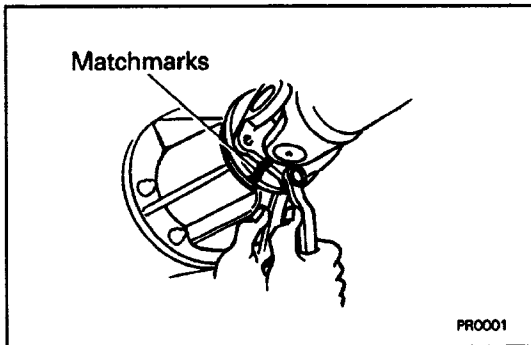

## 7. CONNECT PROPELLER SHAFT FLANGE TO COMPANION FLANGE ON REAR DIFFERENTIAL

- (a) Align the matchmarks on the flanges and connect the flanges with bolts and nuts.
- (b) Torque the bolts and nuts.

### Torque:

**3VZ-E [MT]**

**76 N-m (780 kgf-cm, 56 ft-lbf)**

**Ex. 3VZ-E [MT]**

**74 N-m (760 kgf-cm, 54 ft-lbf)**

# SERVICE SPECIFICATIONS

## SERVICE DATA

PR013-04

Propeller shaft runout	Limit	0.8 mm (0.031 in.)
Spider bearing axial play		0.05 mm (0.0020 in.)
Spider bearing selection	Mark	
Bearing cup outer diameter	None	29.008 – 29.021 mm (1.1420 – 1.1426 in.)
	Red	29.028 – 29.041 mm (1.1428 – 1.1433 in.)
Bearing hole inner diameter	None	29.000 – 29.020 mm (1.1417 – 1.1425 in.)
	Drill	29.021 – 29.042 mm (1.1426 – 1.1434 in.)
Snap ring thickness	TMC – made	mark color
		1 – 2.100 – 2.150 mm (0.0827 – 0.0846 in.)
		2 – 2.150 – 2.200 mm (0.0846 – 0.0866 in.)
		3 – 2.200 – 2.250 mm (0.0866 – 0.0886 in.)
		– Brown 2.250 – 2.300 mm (0.0886 – 0.0906 in.)
		– Blue 2.300 – 2.350 mm (0.0906 – 0.0925 in.)
		6 – 2.350 – 2.400 mm (0.0925 – 0.0945 in.)
		7 – 2.400 – 2.450 mm (0.0945 – 0.0965 in.)
		8 – 2.450 – 2.500 mm (0.0965 – 0.0984 in.)
	DANA-made	color
		Blue 1.638 mm (0.0645 in.)
		Yellow 1.588 mm (0.0625 in.)
		Silver 1.537 mm (0.0605 in.)
		Copper 1.511 mm (0.0595 in.)
		Black 1.486 mm (0.0585 in.)
		Red 1.435 mm (0.0565 in.)
		Green 1.384 mm (0.0545 in.)

**TORQUE SPECIFICATIONS**

Part tightened	N-m	kgf-cm	ft-lbf
Front differential x Front propeller shaft (4WD)	74	750	54
Front propeller shaft x Transfer (4WD)	74	750	54
Propeller shaft x Rear differential	76	780	56
3VZ-E (M/T)	74	750	54
Ex. 3VZ-E (M/T)	74	750	54
Propeller shaft x Transfer	76	780	56
3VZ-E (M/T)	74	750	54
Ex. 3VZ-E (M/T)	74	750	54
Intermediate shaft x Propeller shaft (4WD)			
3VZ-E (M/T)	76	780	56
Ex. 3VZ-E (M/T)	74	750	54
Propeller shaft x Differential (2WD)	74	750	54
Intermediate shaft x Propeller shaft (2WD)	74	750	54
Center support bearing x Frame	36	370	27
Intermediate shaft x Center bearing x Joint flange			
1st	181	1,850	134
2nd		Loosen nut	
3rd	69	700	51
Front propeller shaft No.2 dust cover set bolts	17	175	13
Front propeller shaft No.2 dust cover set nut (w/VF1 A type transfer and A340H)	13	135	10
Front propeller shaft dust cover subassembly x Bracket	23	230	17
Front propeller shaft dust cover subassembly x Transfer	37	370	27
Propeller shaft protector x Frame	29	300	22



# SUSPENSION AND AXLE

# TROUBLESHOOTING

Problem	Possible cause	Remedy	Page	
			2WD	4WD
Wanders/pulls	Tires worn or improperly inflated Alignment incorrect Wheel bearing adjusted too tight Front or rear suspension parts loose or broken Steering linkage loose or worn Steering gear out of adjustment or broken	Inflate tires to proper pressure or replace tires Check front alignment Adjust wheel bearing Tighten or replace suspension parts Tighten or replace steering linkage Adjust or repair steering gear	SA-3 SA-13 SA-17, 153	SA-6 SA-39 SA-111, 153
Bottoming	Vehicle overloaded Shock absorber worn out Springs weak	Check loading Replace shock absorber Replace spring	SA-22, 153 SA-20, 153	SA-116, 153 SA-114, 153
Sways/pitches	Tires improperly inflated Stabilizer bar bent or broken Shock absorber worn out	Inflate tires to proper pressure Inspect stabilizer bar Replace shock absorber	SA-28, 157 SA-22, 153	SA-122 SA-1 16, 153
Front wheel shimmy	Tires worn or improperly inflated Wheels out of balance Shimmy damper worn out Shock absorber worn out Alignment incorrect Wheel bearings worn or improperly adjusted Ball joints or bushings worn Steering linkage loose or worn Steering gear out of adjustment or broken	Replace tire or inflate tires to proper pressure Balance wheels Replace steering damper Replace shock absorber Check front alignment Replace or adjust wheel bearings Inspect ball joints and bushings Tighten or replace steering linkage Adjust or repair steering gear	SA-22, 153 SA-3 SA-12 SA-18	SA-116, 153 SA-6 SA-36 SA-112
Abnormal tire wear	Tires improperly inflated Shock absorbers worn out Alignment incorrect Suspension parts worn	Inflate tires to proper pressure Replace shock absorber Check toe-in Replace suspension parts	SA-22, 153 SA-5 SA-17, 153	SA-116, 153 SA-9 SA-111, 153
Oil leak from differential	Oil level too high or wrong grade Oil seal worn or damaged Companion flange loose or damaged	Drain and replace oil Replace oil seal Tighten or replace flange	SA-136 SA-135 SA-149	SA-57, 136 SA-54, 135 SA-56, 149
Noises in axle	Oil level low or wrong grade Excessive backlash between pinion and ring or side gear Ring, pinion or side gears worn or chipped Pinion shaft bearing worn  Axle shaft bearing worn Differential bearing loose or worn	Drain and replace oil Check backlash  Inspect gears  Replace bearing  Replace bearing Tighten or replace bearings	SA-136 SA-137  SA-137  SA-137  SA-124 SA-137	SA-57, 136 SA-68, 85 137 SA-66, 82, 137 SA-66, 82, 137 SA-124 SA-66, 82, 137

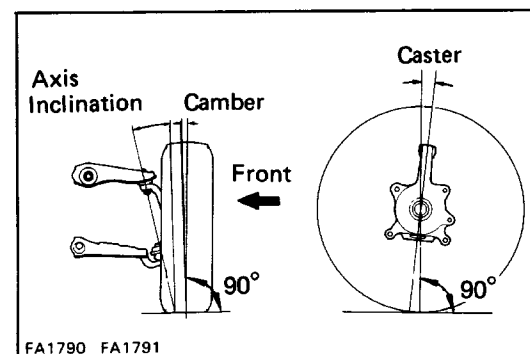
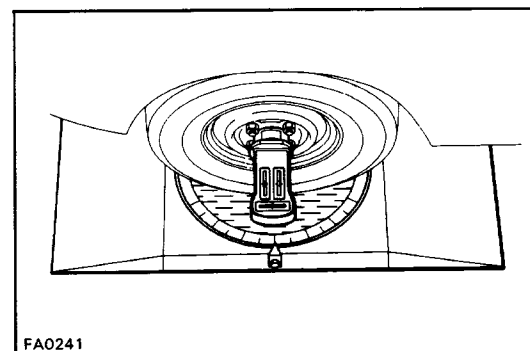
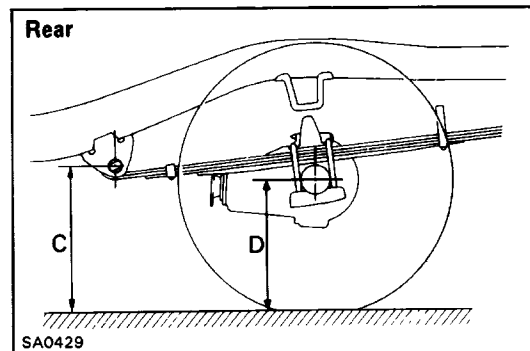
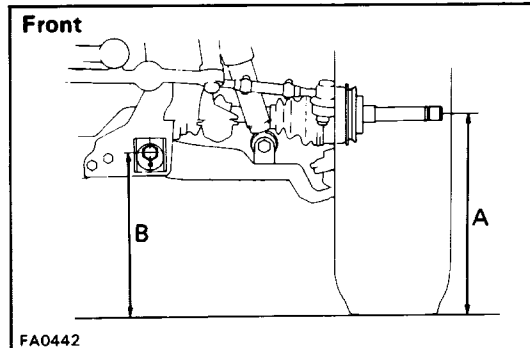
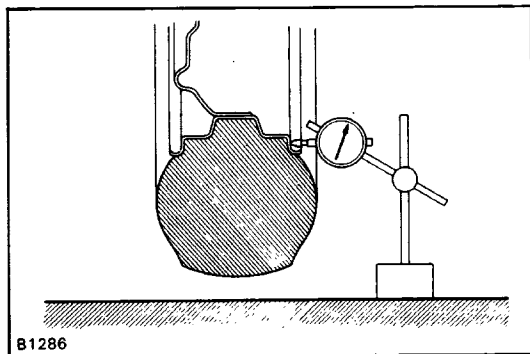

## WHEEL ALIGNMENT 4WD

### 1. MAKE FOLLOWING CHECKS AND CORRECT ANY PROBLEMS

- (a) Check the tires for wear and proper inflation.  
**Cold tire inflation pressure: See page A-25**
- (b) Check the wheel runout.  
**Lateral runout: 1.2 mm (0.047 in.) or less**
- (c) Check the front wheel bearings for looseness.
- (d) Check the front suspension for looseness.
- (e) Check the steering linkage for looseness.
- (f) Check that the front absorbers work properly by using the standard bounce test.

### 2. ADJUST VEHICLE HEIGHT

Adjust the vehicle height to the standard vehicle height for wheel alignment inspection.

HINT: With non-loaded vehicles, there is a difference in the vehicle height according to the model.

Although the wheel alignment standard value changes according to the vehicle height, by setting the vehicle height to the standard height the standard alignment value becomes the same for all models.

**Front:  $A - B = 58.5 \text{ mm (2.303 in.)}$**

**A: Height at center of tip of drive shaft**

**B: Height at center of tip of front side adjusting cam bolt**

**Rear:  $C - D = 61.0 \text{ mm (2.402 in.)}$**

**C: Height of center of rear leaf spring front bush 1**

**D: Height of center of rear axle shaft**

HINT: For the vehicle height of non-loaded vehicles for each model and the alignment standard values, refer to page A-25.

### 3. INSTALL WHEEL ALIGNMENT EQUIPMENT

Follow the specific instructions of the equipment manufacturer.

### 4. ADJUST CAMBER, STEERING AXIS INCLINATION AND CASTER

Camber, Steering axis inclination, Caster: See page A-25, 26

If the steering axis inclination is not as specified after camber and caster have been correctly adjusted, re-check the steering knuckle and front wheel for bending or looseness.

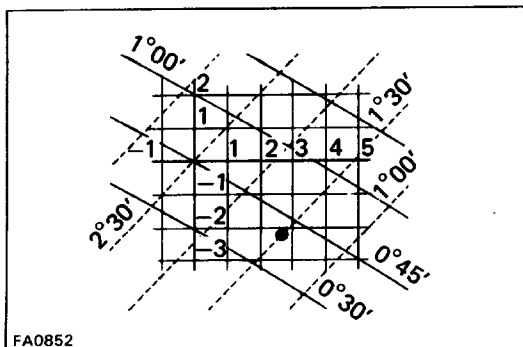
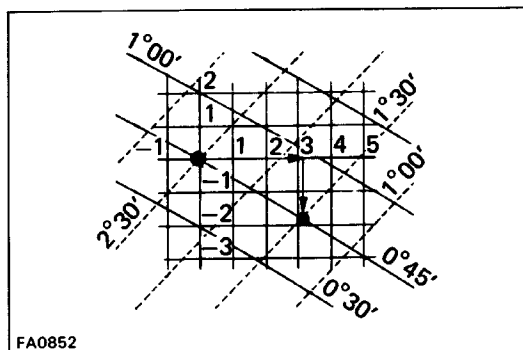
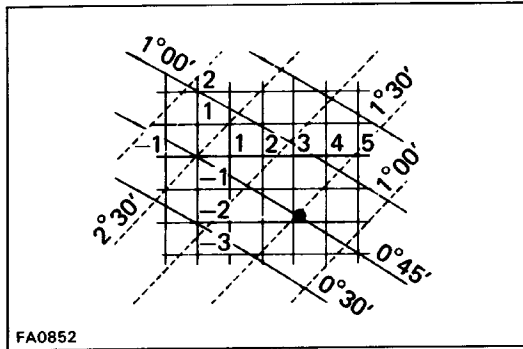
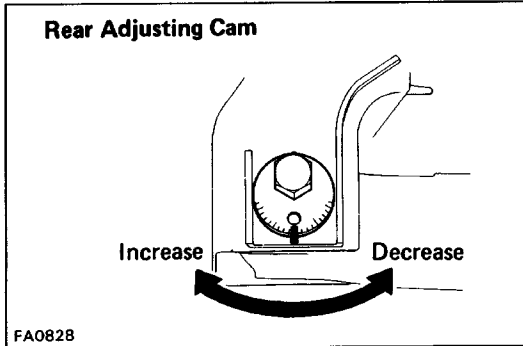
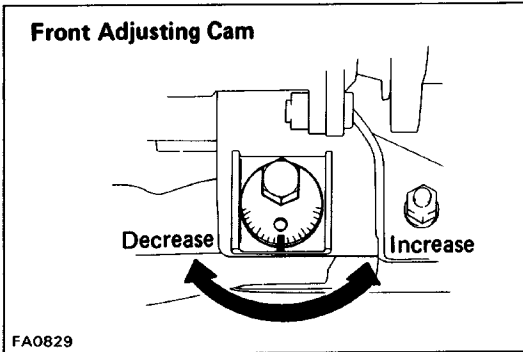

If camber and/or caster are not within specification, adjust by front and/or rear adjusting cams.  
(See Adjustment Chart)

**How to Read the Chart**

**(Alignment measured with vehicle height set to standard height for wheel alignment inspection)**

- (a) Mark on the adjustment chart the alignment values measured with the vehicle at standard height.

**Example: Camber 0°45'**  
**Caster 1°30'**

- (b) To calculate the amounts by which the front and/or rear cams are to be adjusted, read from the adjustment chart the distance from the center of the chart to the mark you have made, as shown in the illustration.

**Example: Front cam -1.8**  
**Rear cam + 3.1**

- (c) Torque the front and/or rear cam nuts.  
**Torque: 196 N-m (2,000 kgf-cm, 145 ft-lbf)**

**How to Read the Chart**

**(Wheel alignment measured at vehicle height of non-loaded vehicle)**

- (a) Find the wheel alignment standard value applicable for the particular model in non-loaded condition.  
(See page A-33)
- (b) Mark the selected standard value on the adjustment chart.

**Example: Camber 0°40'**  
**Caster 1°30'**

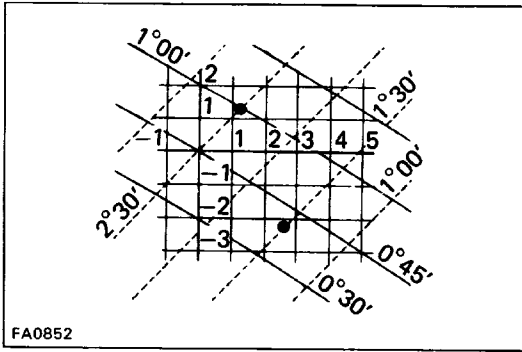

- (c) Mark on the adjustment chart the alignment values measured at the non-loaded vehicle height.  
**Example: Camber 1°00'**  
**Caster 2°30'**

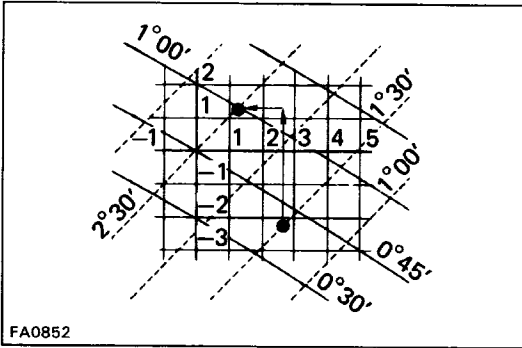

- (d) As shown in the illustration, read the distance from the standard value to the measured value, and adjust the front and/or rear adjusting cams accordingly.  
**Example: Front cam + 3.4**  
**Rear cam -1.6**
- (e) Torque the front and/or rear cam nuts.  
**Torque: 196 N-m (2,000 kgf-cm, 145 ft-lbf)**

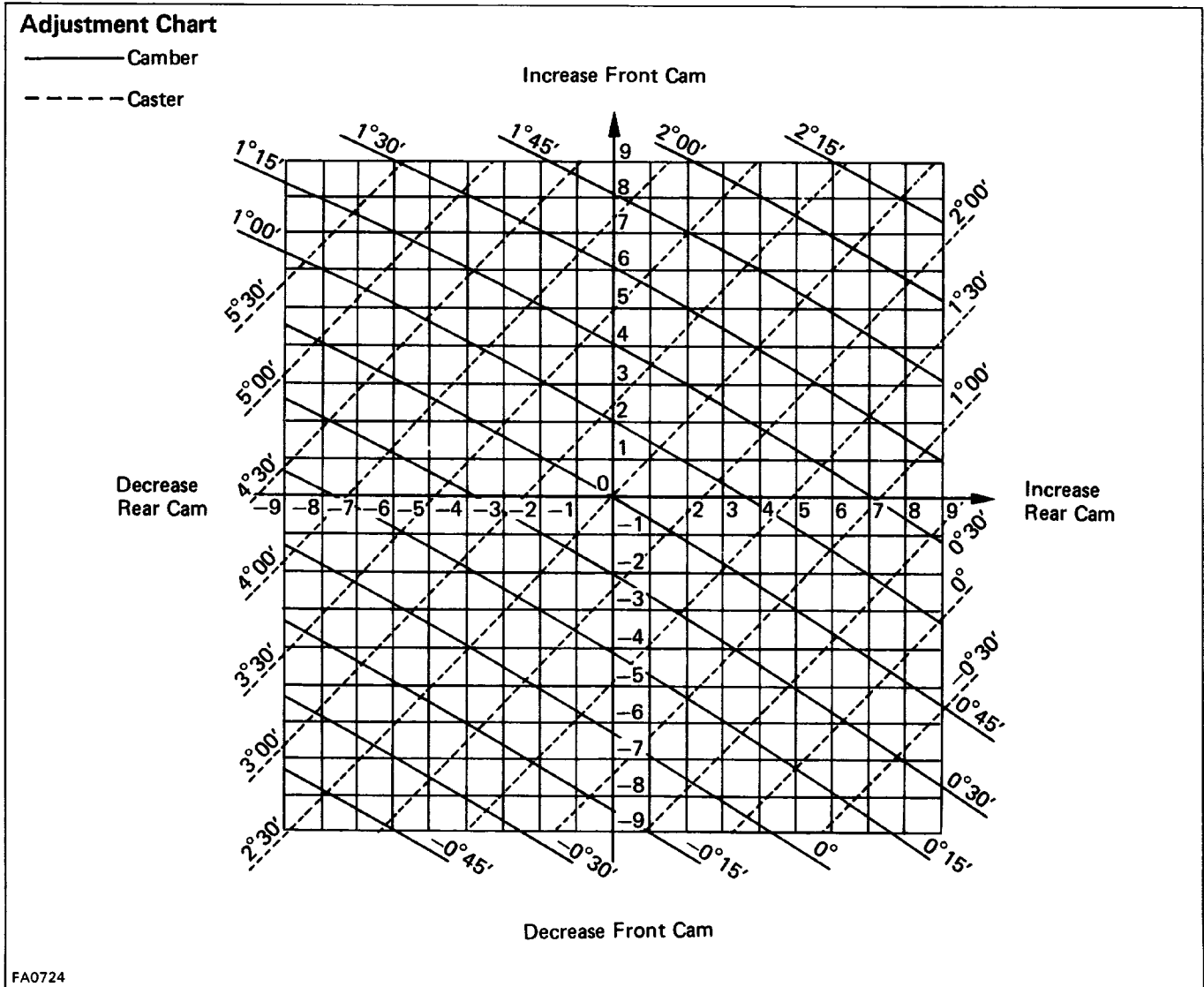

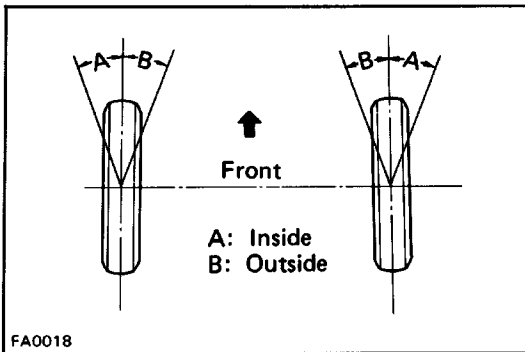

## 5. ADJUST WHEEL ANGLE

Remove the caps of the knuckle stopper bolts and check the steering angles.

Wheel angle		
Max.	Inside wheel	$32^{\circ}00' +1^{\circ}$ $-2^{\circ}$
	Outside wheel	$31^{\circ}$
at 200 (outside wheel)	Inside wheel	$21^{\circ} \pm 10'$

**HINT:** When the steering wheel is fully turned, make sure that the wheel is not touching the body or brake flexible hose.

If maximum steering angles differ from standard value, adjust the wheel angle with the knuckle stopper bolts.

**Torque: 47 N-m (480 kgf-cm, 35 ft-lbf)**

If the wheel angle still cannot be adjusted within limits, inspect and replace damaged or worn steering parts.

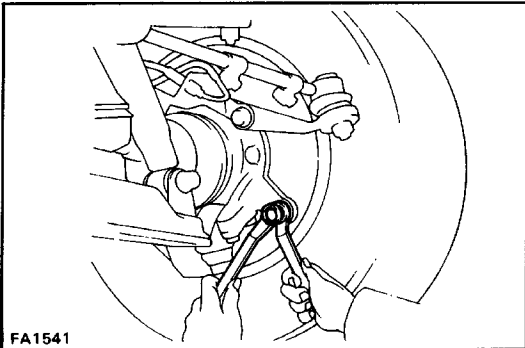

## 6. INSPECT TOE-IN

**Toe-in: See page A-26**

If toe-in is not within specification adjust by the tie rod end.

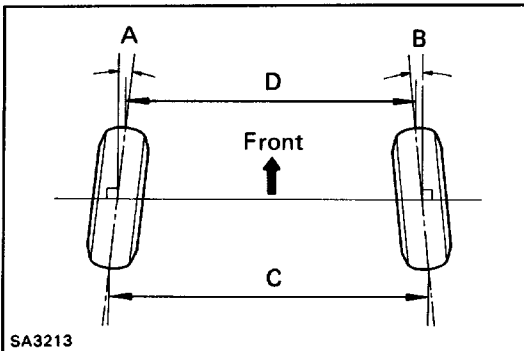

## 7. ADJUST TOE-IN

(a) Loosen the clamp bolts and nuts.

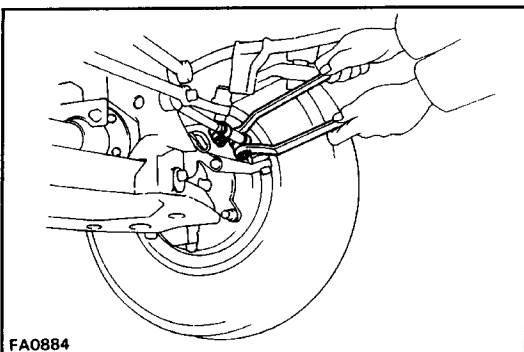

(b) Adjust toe-in by turning the left and right tie rod tubes an equal amount.

**Toe-in: See page A-26**

(c) Insure that the lengths of the left and right tie rods are equal.

**NOTICE: Check that the steering wheel is straightened.**

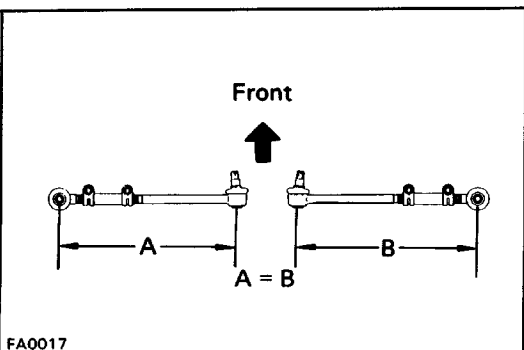

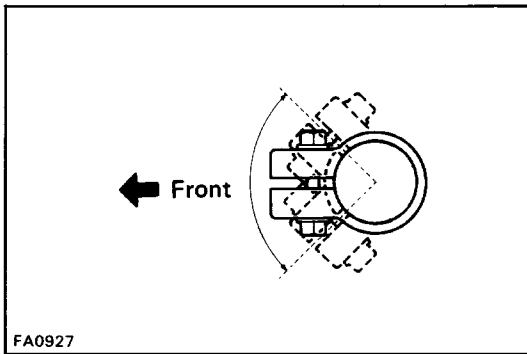

(d) Torque the tie rod.

**Torque: 22 N-m (225 kgf-cm, 16 ft-lbf)**

**HINT:** Face the clamp bolt toward the front of the vehicle.

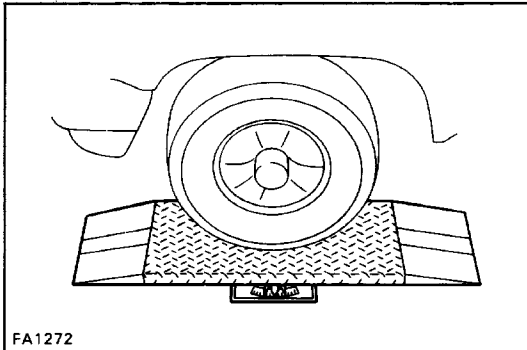

### 8. INSPECT SIDE SLIP (REFERENCE ONLY)

Side slip: 3.0 mm/m (0.118 in./3.3 ft) or less

# WHEEL ALIGNMENT

## 2WD

### 1. MAKE FOLLOWING CHECKS AND CORRECT ANY PROBLEMS

- (a) Check the tires for wear and proper inflation.  
Cold tire inflation pressure: See page A-23

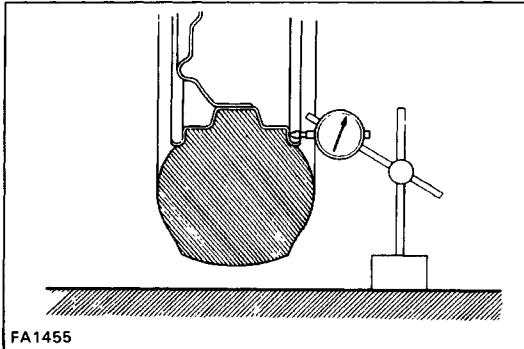

FA1455

- (b) Check the wheel runout.

Lateral runout: 1.2 mm (0.047 in.) or less

- (c) Check the front wheel bearings for looseness.  
(d) Check the front suspension for looseness.  
(e) Check the steering linkage for looseness.  
(f) Use the standard bounce test to check that the front absorbers work properly.

### 2. MEASURE CHASSIS GROUND CLEARANCE

**Chassis ground clearance: See page A-23**

If the clearance of the vehicle is not standard, try to adjust it by pushing down on the body or by lifting the body. If still not correct, check for bad springs or suspension parts.

**HINT:** Before inspecting wheel alignment, adjust chassis ground clearance to specification.

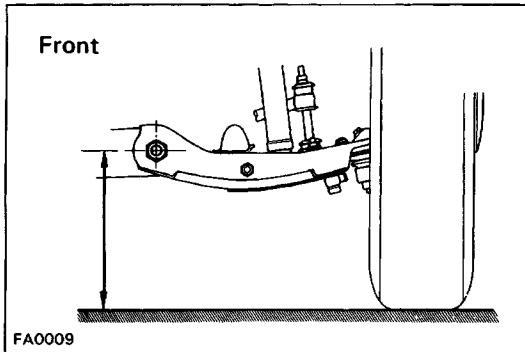

FA0009

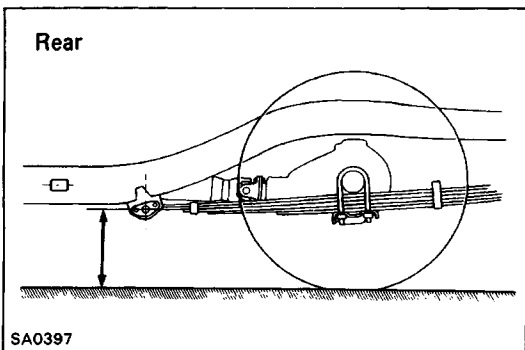

SA0397



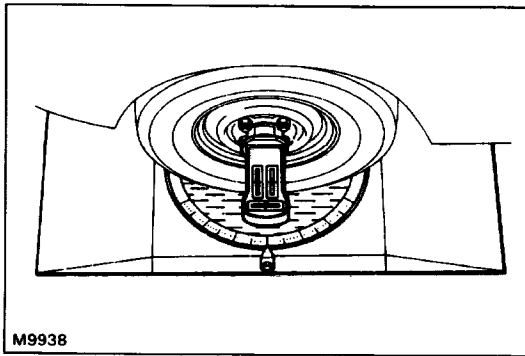

### 3. INSTALL WHEEL ALIGNMENT EQUIPMENT

Follow the specific instructions of the equipment manufacturer.

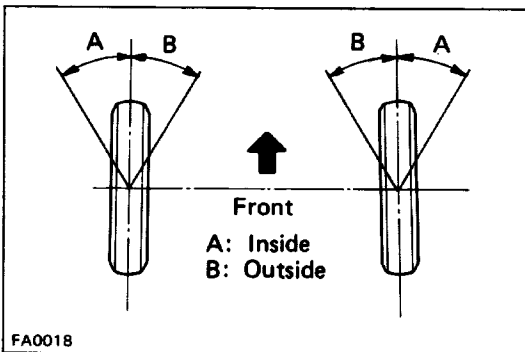

### 4. ADJUST WHEEL ANGLE

Remove the caps of the knuckle stopper bolts and check the steering angles.

**Steering angles: See page A-24**

**HINT:** When the steering wheel is fully turned, make sure that the wheel is not touching the body or brake flexible hose.

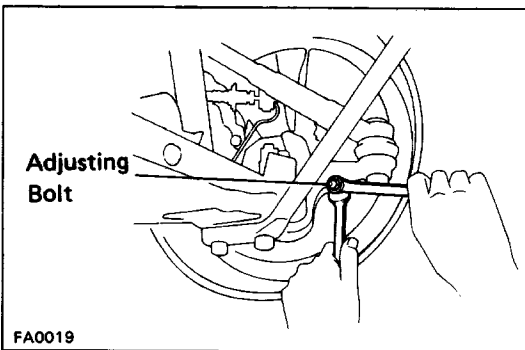

If maximum steering angles differ from standard value, adjust the wheel angle with the knuckle stopper bolts.

**Torque: 34 N-m (350 kgf-cm, 25 ft-lbf)**

If the wheel angle still cannot be adjusted within limits, inspect and replace damaged or worn steering parts.

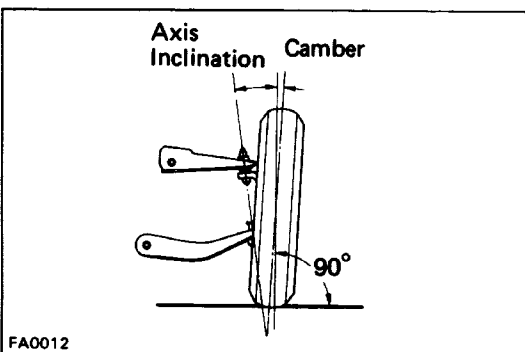

### 5. ADJUST CAMBER, STEERING AXIS INCLINATION AND CASTER

**Specifications: See page A-23, 24**

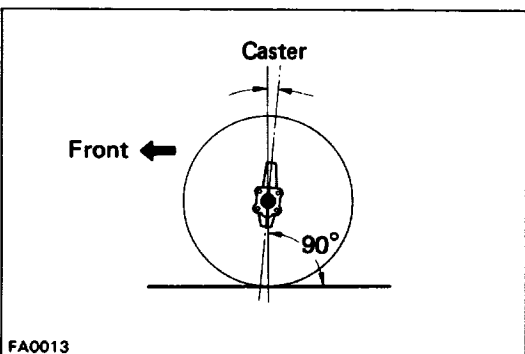

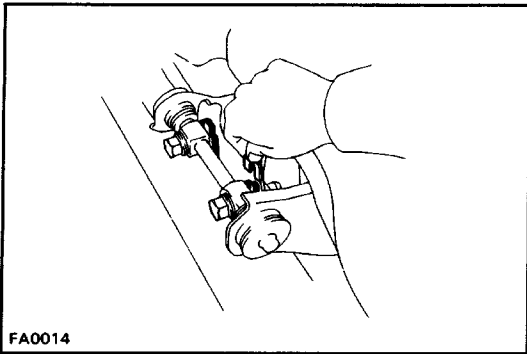

If camber caster is not within specification, adjust by adding or removing shims on the upper arm.

Shim thickness mm (in. )

Thickness	
4.0	(0.157)
1.6	(0.063)
1.2	(0.047)

If the steering axis inclination is not as specified after camber and caster have been correctly adjusted, recheck the steering knuckle and front wheel for bending or looseness.

## 6. INSPECT TOE-IN

**Toe-in: See page A-23**

If toe-in is not within specification adjust by the tie rod end.

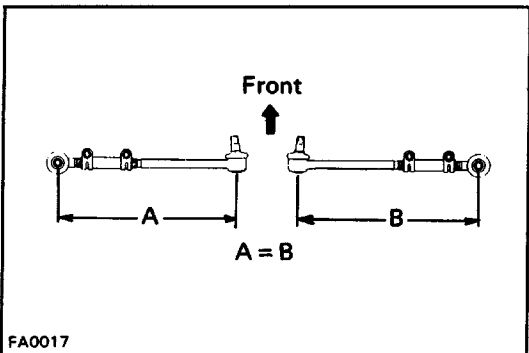
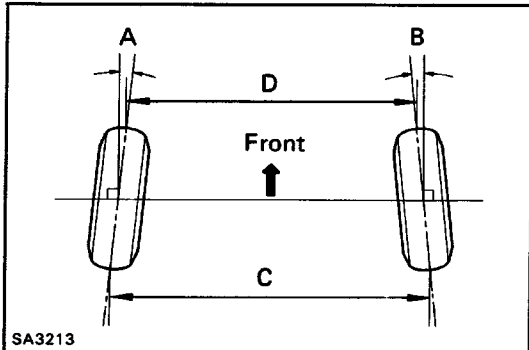

## 7. ADJUST TOE-IN

- Loosen the clamp bolts.
- Adjust toe-in by turning the left and right tie rod tubes an equal amount.

**Toe-in: See page A-23**

HINT: Make sure that the tie rods are the same length.

**Left-right error: 3.0 mm (0.118 in.) or less**

- Tighten the clamp bolts and torque them.

**Torque: 25 N-m (260 kgf-cm, 19 ft-lbf)**

## 8. INSPECT SIDE SLIP (REFERENCE ONLY)

**Side slip: 3.0 mm/m (0.118 in. 13.3 ft) or less**

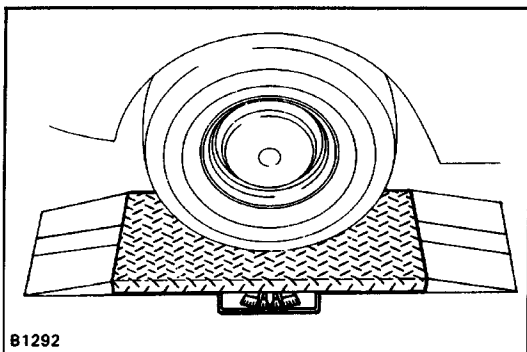

# FRONT AXLE HUB AND STEERING KNUCKLE COMPONENTS

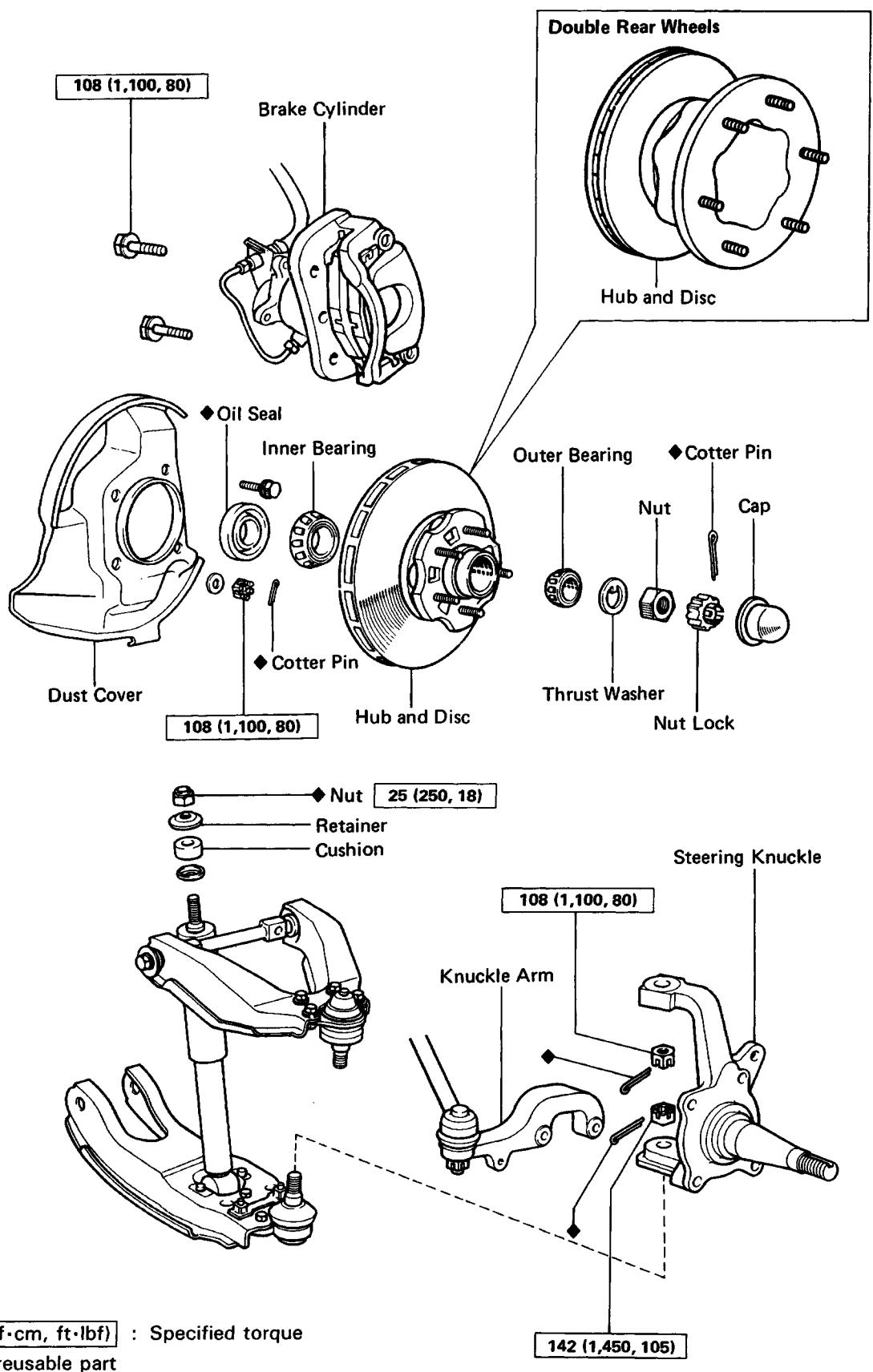

N·m (kgf·cm, ft·lbf) : Specified torque

◆ Non-reusable part

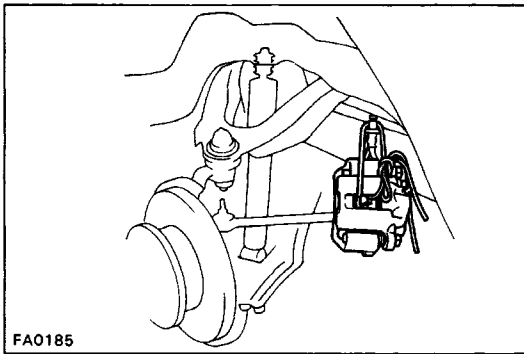

## Front Axle Hub

(See page SA-11)

### DISASSEMBLY OF FRONT AXLE HUB

#### 1. REMOVE DISC BRAKE CYLINDER AND TORQUE PLATE

- (a) Remove the brake cylinder and suspend it with wire.
- (b) Remove the torque plate.

HINT: Do not disconnect the brake tube and hose.

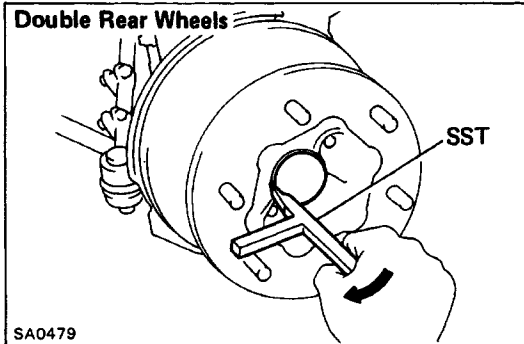

#### 2. REMOVE AXLE HUB WITH DISC

- (a) (Single rear wheel)  
Remove the cap.
- (Double rear wheels)  
Using SST, pry off the cap.

SST 09504-22011

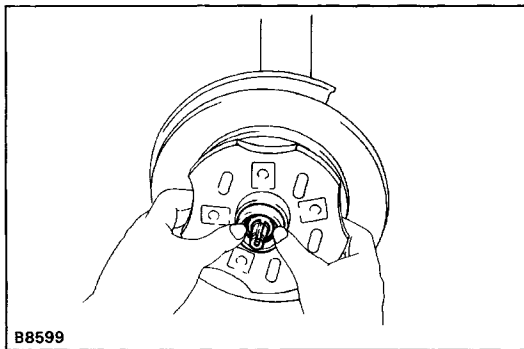

- (b) Remove the hub and disc together with the outer bearing and thrust washer.

HINT: Be careful not to drop the outer bearing.

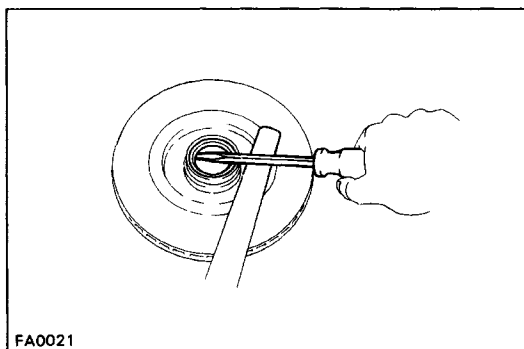

#### 3. REMOVE INNER BEARING AND OIL SEAL

- (a) Using a screwdriver, pry out the oil seal.
- (b) Remove the inner bearing from the hub.

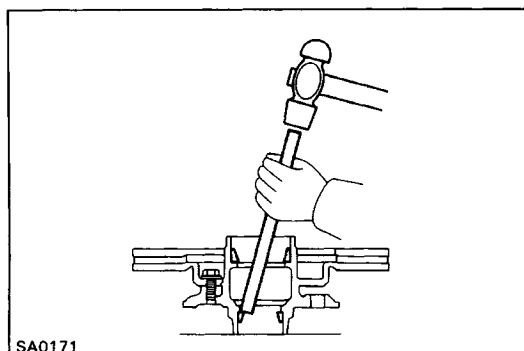

### INSPECTION AND REPAIR OF FRONT AXLE HUB

#### 1. INSPECT BEARING

Clean the bearings and outer races and inspect them for wear or damage.

#### 2. REPLACE BEARING OUTER RACE

- (a) Using a brass bar and hammer, drive out the bearing outer race.

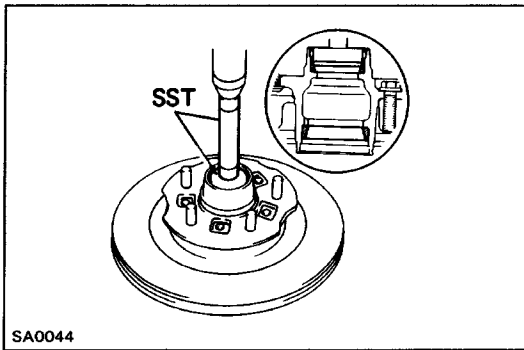

- (b) Using SST, carefully drive in a new bearing outer race.

SST 09608-30012

(Inside race 09608-04020, 09608-04100)

(Outside race 09608-04020, 09608-04060)

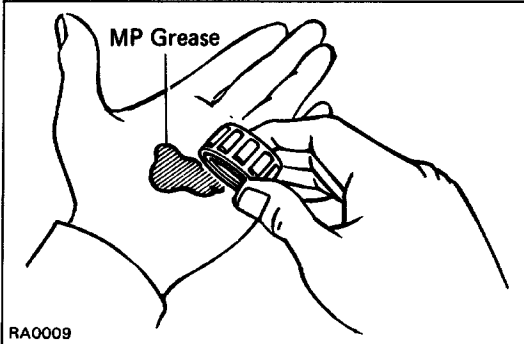

## ASSEMBLY OF FRONT AXLE HUB

### 1. PACK BEARINGS WITH MP GREASE

- (a) Place MP grease in the palm of your hand.
- (b) Pack grease into the bearing, continuing until the grease oozes out from the other side.
- (c) Do the same around the bearing circumference.

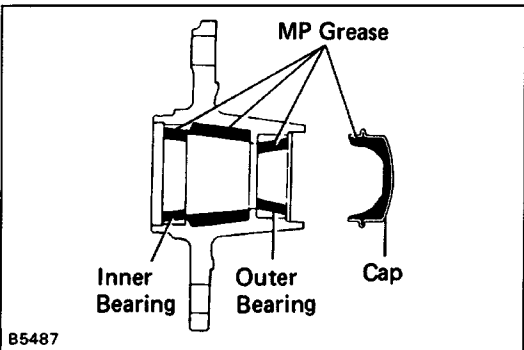

### 2. COAT INSIDE OF HUB AND CAP WITH MP GREASE

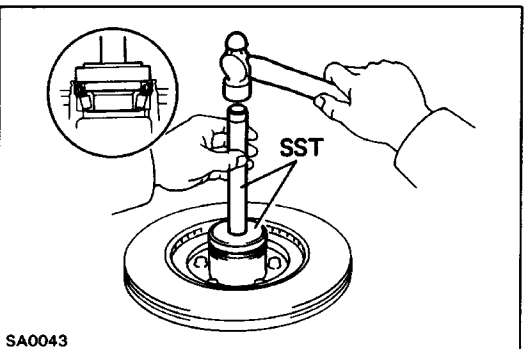

### 3. INSTALL INNER BEARING AND OIL SEAL

Place inner bearing into the hub. Using SST, drive the oil seal into the hub. Coat the oil seal with MP grease.

SST 09608-30012 (09608-04020, 09608-04100)

### 4. INSTALL AXLE HUB ON SPINDLE

- (a) Place the axle hub on the spindle.
- (b) Install the outer bearing and thrust washer.

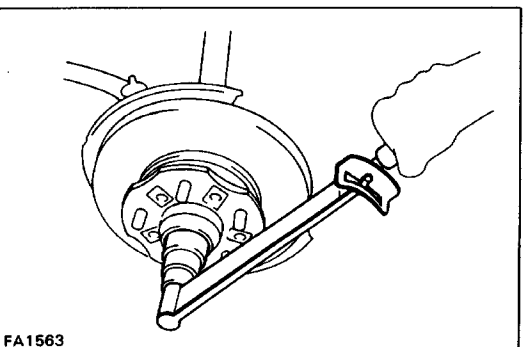

### 5. ADJUST PRELOAD

- (a) Install and torque the nut.

Torque: 34 N-m (350 kgf-cm, 25 ft-lbf)

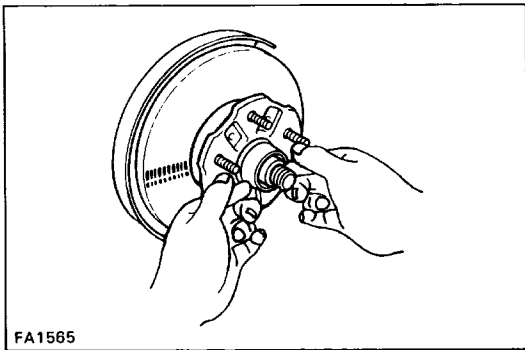

(b) Snug down the bearing by turning the hub several times.

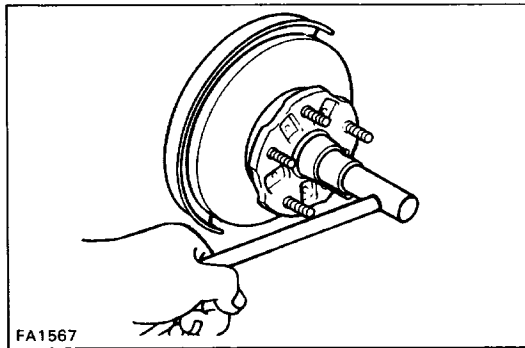

(c) Loosen the nut until it can be turned by hand.

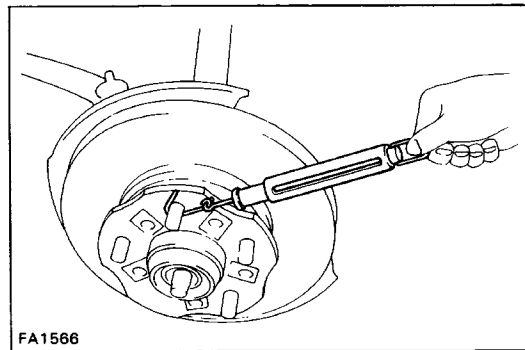

(d) Using a spring tension gauge, measure and make a note of the frictional force of the oil seal.

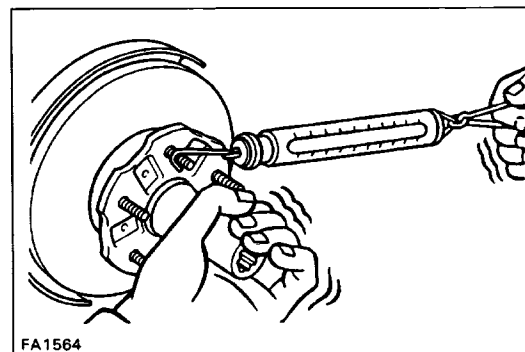

(e) Tighten the nut until the preload is within specification.

**Preload (starting):**

**Add oil seal frictional force**

**Single rear wheel**

5.9– 17.7N(0.6– 1.8kgf, 1.3–4.–lbf)

**Double rear wheels**

3.9–9.8N(0.4– 1.0kgf,0.9–2.2lbf)

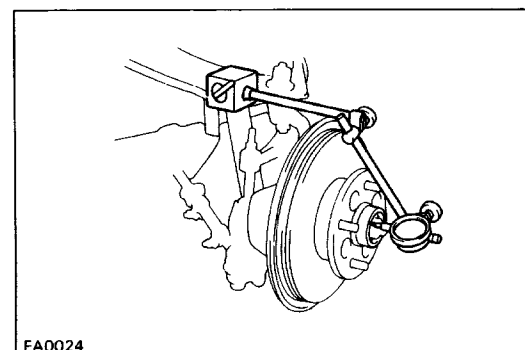

(f) Measure the hub axial play.

**Axial play: 0.05 mm (0.0020 in.) or less**

**6. INSTALL LOCK NUT, COTTER PIN AND GREASE CAP**  
**7. INSTALL BRAKE CYLINDER AND TORQUE PLATE ONTO STEERING KNUCKLE**

**Torque: 34 N–m (350 kgf–cm, 25 ft–lbf)**

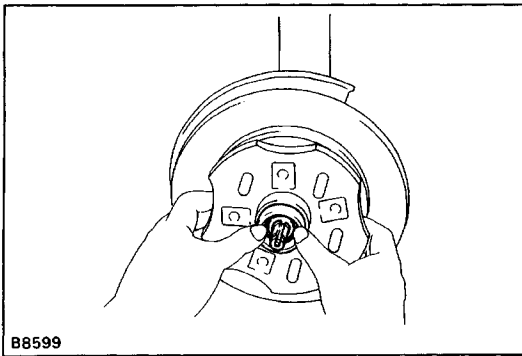

B8599

## Steering Knuckle

(See page SA-11)

### REMOVAL OF STEERING KNUCKLE

#### 1. REMOVE FRONT AXLE HUB AND BRAKE CALIPER

(See page SA-12)

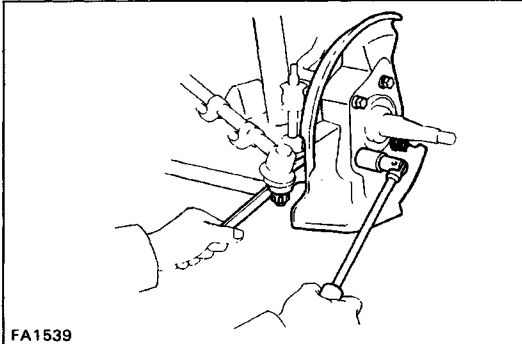

FA1539

#### 2. REMOVE DUST COVER

- (a) Remove the two bolts.
- (b) Remove the two cotter pins, nuts and bolts and remove the dust cover.
- (c) Remove the knuckle arm from the steering knuckle.

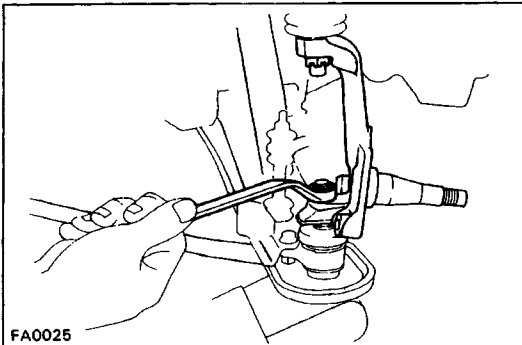

FA0025

#### 3. REMOVE STEERING KNUCKLE

- (a) Support the lower arm with a jack.
- (b) Remove the two cotter pins and two nuts.

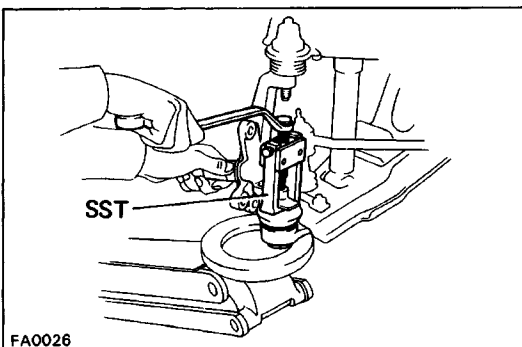

FA0026

- (c) Using SST, disconnect the steering knuckle from the lower ball joint.

SST 09628-62011

- (d) Using SST, disconnect the steering knuckle from the upper ball joint.

SST 09628-62011

- (e) Remove the steering knuckle.

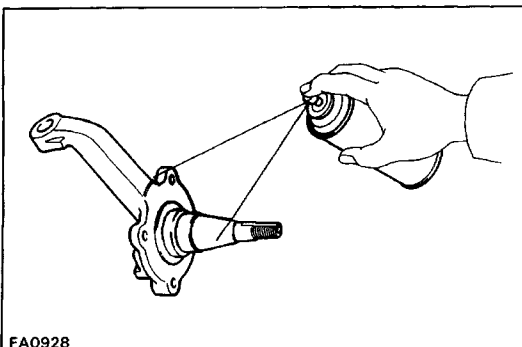

FA0928

### INSPECTION OF STEERING KNUCKLE

#### INSPECT STEERING KNUCKLE

Using a dye penetrant, check the steering knuckle for cracks.

If a crack is found, replace the steering knuckle.

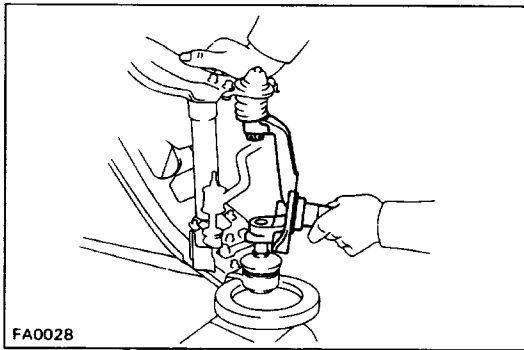

## INSTALLATION OF STEERING KNUCKLE

### 1. INSTALL STEERING KNUCKLE

- (a) Support the lower arm with a jack.
- (b) Install the steering knuckle to the upper ball joint and install the nut.
- (c) Push the upper arm and steering knuckle down and install the steering knuckle to the lower ball joint and install the nut.

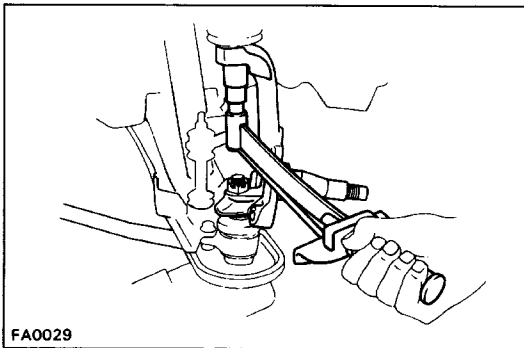

- (d) Torque the upper ball joint nut.  
**Torque: 108 N-m (1,100 kgf-cm, 80 ft-lbf)**
- (e) Torque the lower ball joint nut.  
**Torque: 142 N-m (1,450 kgf-cm, 105 ft-lbf)**
- (f) Install new cotter pins.

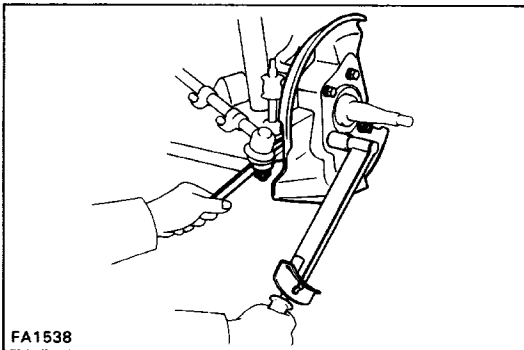

### 2. INSTALL KNUCKLE ARM AND DUST COVER

- (a) Install the knuckle arm and the dust cover.
- (b) Torque the bolts and nuts.  
**Torque: 108 N-m (1,100 kgf-cm, 80 ft-lbf)**
- (c) Secure the nuts with new cotter pins.

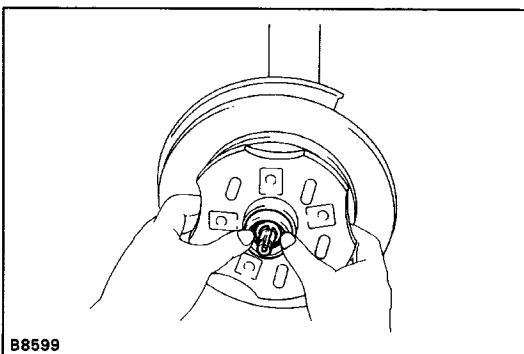

### 3. INSTALL FRONT AXLE HUB AND BRAKE CALIPER

(See page [SA-13](#))

### 4. CHECK FRONT WHEEL ALIGNMENT

(See page [SA-3](#))



# FRONT SUSPENSION COMPONENTS

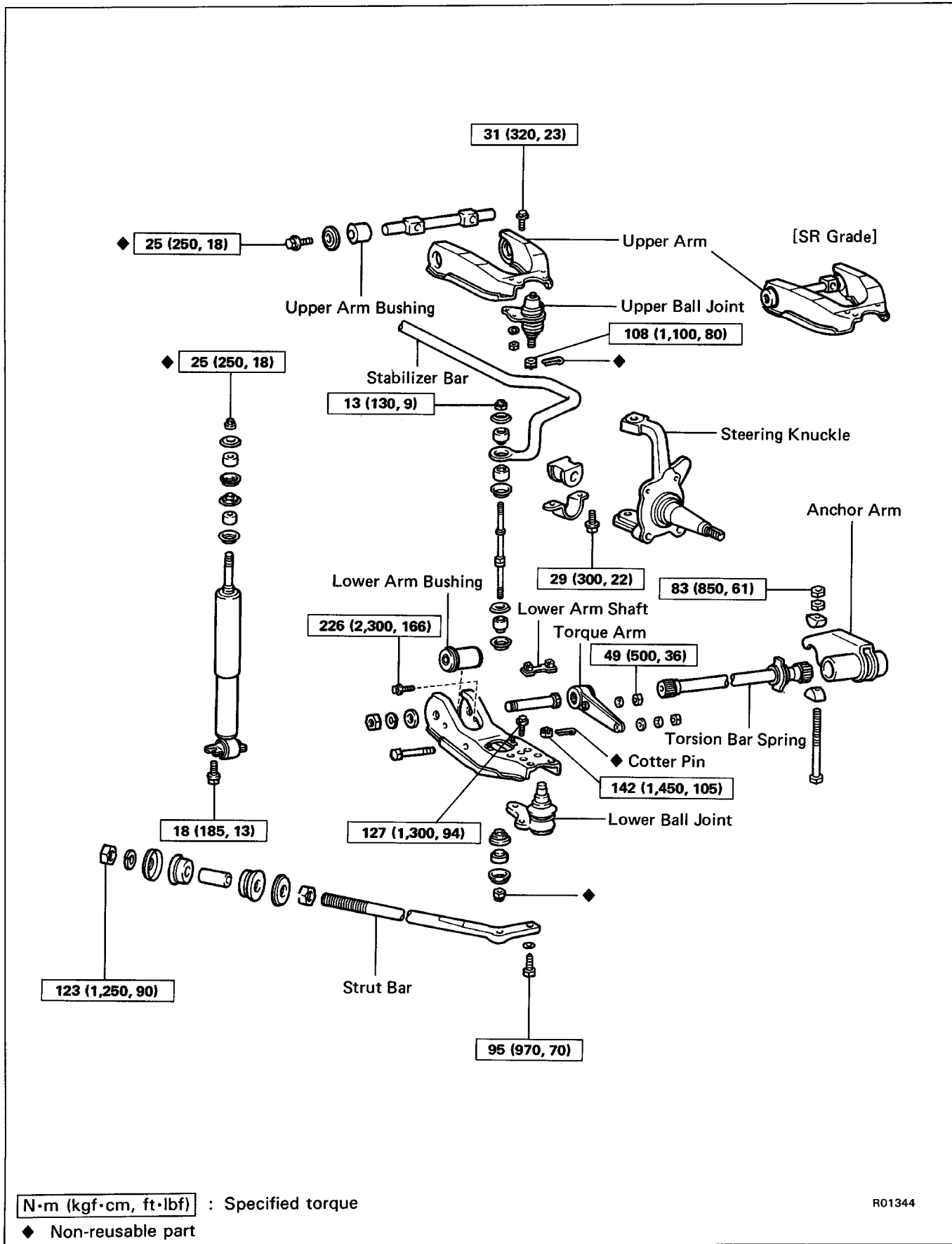

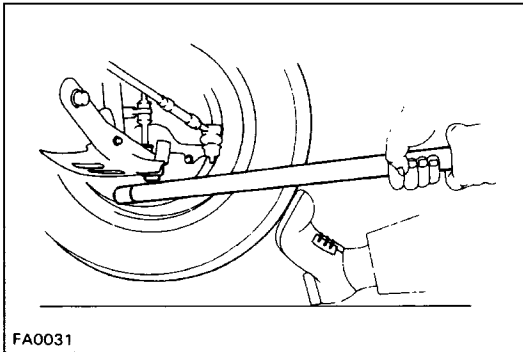

FA0031

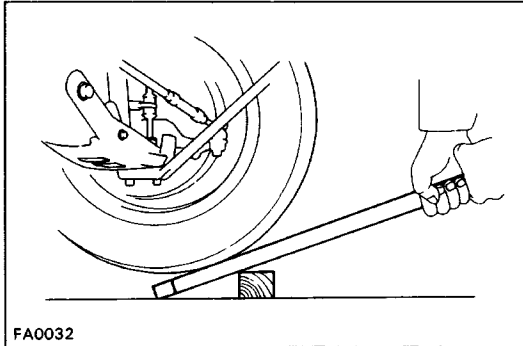

FA0032

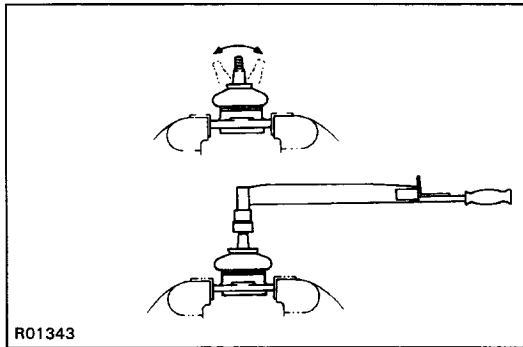

R01343

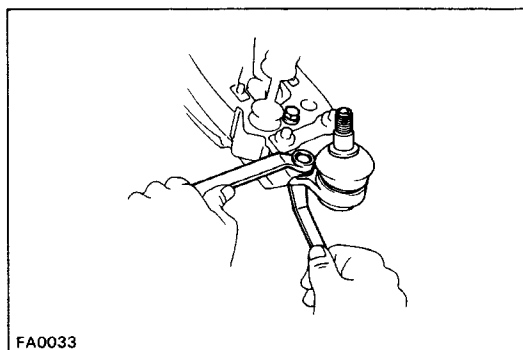

FA0033

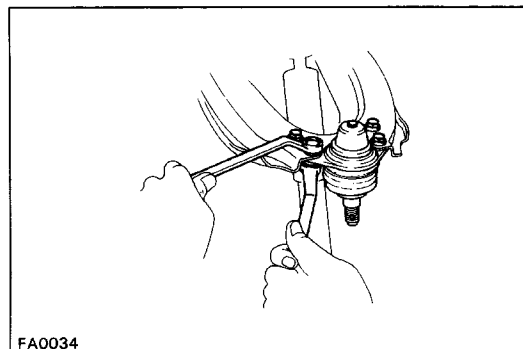

FA0034

## Ball Joint

(See page SA-17)

### INSPECTION OF BALL JOINTS

#### 1. INSPECT LOWER BALL JOINT FOR EXCESSIVE LOOSENESS

- Jack up the front of the vehicle and support it with stands.
- Make sure the front wheels are in a straight forward position, and depress the brake pedal.
- Move the lower arm up and down and check that the lower ball joint has no excessive play.

**Maximum vertical play: 0 mm (0 in.)**

#### 2. INSPECT UPPER BALL JOINT FOR EXCESSIVE LOOSENESS

Move the wheel up and down and check that the upper ball joint has no excessive play.

**Maximum vertical play: 2.3 mm (0.091 in.)**

#### 3. INSPECT BALL JOINT ROTATION CONDITION

- Remove the ball joint.
- As shown in the figure, flip the ball joint stud back and forth 5 times before installing the nut.
- Using a torque gauge, turn the nut continuously one turn every 2–4 seconds and take the torque reading on the 5th turn.

**Torque (turning):**

**Lower ball joint**    0.1 – 4.9 N-m  
(1– 50 kgf -cm, 1 – 43 in.-lbf)

**Upper ball joint** 2.0 – 3.9 N-m  
(20– 40 kgf -cm, 17 – 35 in.-lbf)

### REMOVAL OF BALL JOINTS

#### 1. REMOVE STEERING KNUCKLE

(See page SA-15 )

#### 2. REMOVE LOWER BALL JOINT FROM LOWER ARM

#### 3. REMOVE UPPER BALL JOINT FROM UPPER ARM

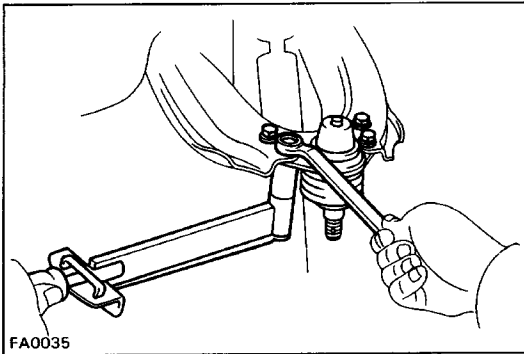
**INSTALLATION OF BALL JOINTS****1. INSTALL UPPER BALL JOINT TO UPPER ARM**

Torque: 31 N-m (320 kgf-cm, 23 ft-lbf)

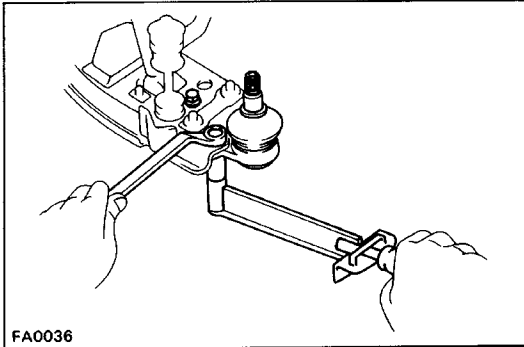
**2. INSTALL LOWER BALL JOINT TO LOWER ARM**

Torque: 127 N-m (1,300 kgf-cm, 94 ft-lbf)

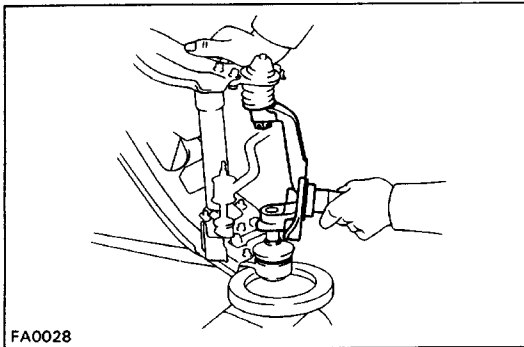
**3. INSTALL STEERING KNUCKLE**

(See page [SA-16](#))

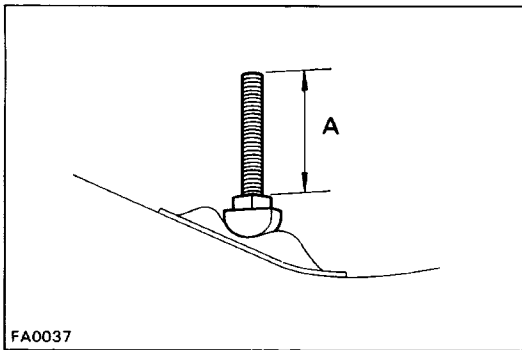

## Torsion Bar Spring

(See page SA-17)

### REMOVAL OF TORSION BAR SPRING

#### 1. JACK UP AND SUPPORT FRAME ON STANDS

#### 2. REMOVE LOCK NUT AND MEASURE PROTRUDING BOLT END "A", AS SHOWN

HINT: Use this measurement for reference when adjusting the chassis ground clearance.

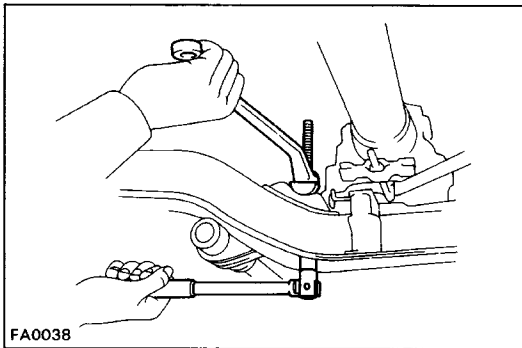

#### 3. REMOVE DUST COVER

#### 4. LOOSEN ADJUSTING NUT UNTIL NO TENSION ON TORSION BAR

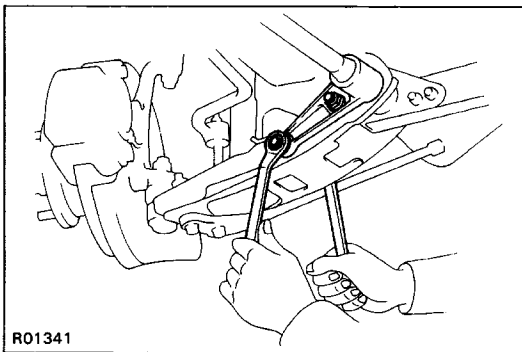

#### 5. REMOVE TORQUE ARM, TORSION BAR SPRING AND ANCHOR ARM

- Remove the torque arm mounting nuts.
- Remove the anchor arm from the adjusting bolt and then remove the torsion bar together with the torque arm and anchor arm.

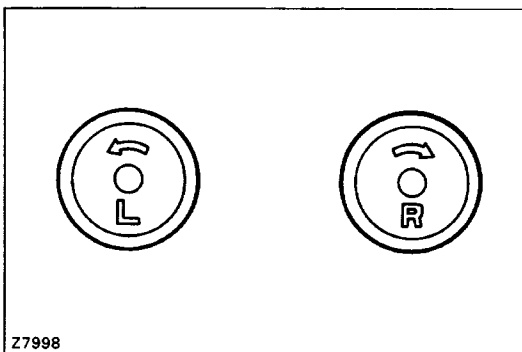

### INSTALLATION OF TORSION BAR SPRING

HINT: There are left and right identification marks on the rear end of the torsion bar springs.

Be careful not to interchange the torsion bar springs.

#### 1. INSTALL TORSION BAR SPRING AND ANCHOR ARM AND TORQUE ARM

- Apply a light coat of MP grease to the spline of the torsion bar spring.
- Align the toothless portion and install the anchor arm to the torsion bar spring.
- Align the toothless portion and install the torque arm to the torsion bar spring.

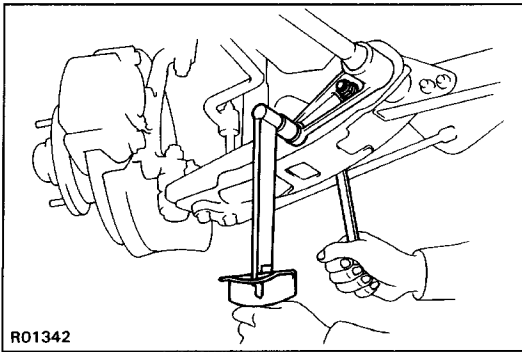

- (d) Install the torsion bar spring torque arm side and install the anchor arm to the adjusting bolt.  
 (e) Torque the torque arm nuts.  
**Torque: 49 N-m (500 kgf-cm, 36 ft-lbf)**

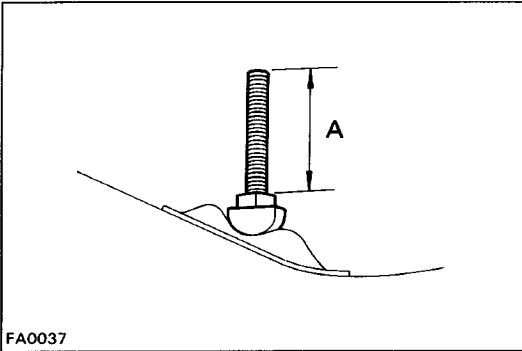

- (f) Tighten the adjusting nut so that the bolt protrusion is equal to that before removal.

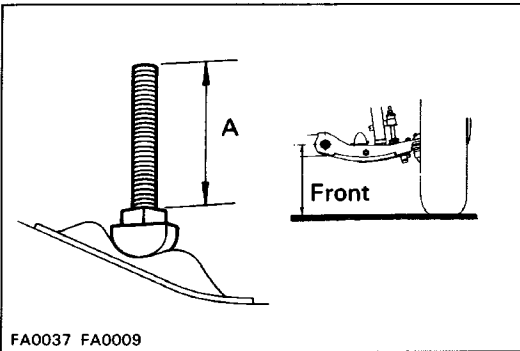

- (g) Install the wheel and remove the stands. Bounce the vehicle to settle the suspension.  
 (h) Adjust the chassis ground clearance by turning the adjusting nut.  
**Chassis ground clearance: See page A-23**

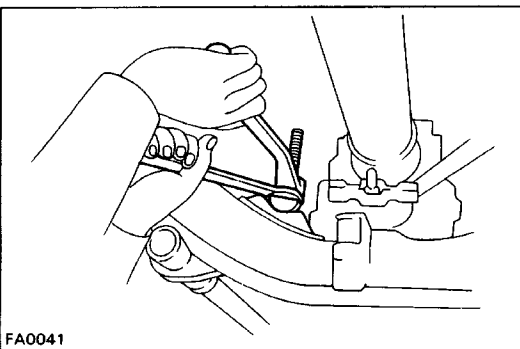

## 2. TORQUE LOCK NUT

**Torque: 83 N-m (850 kgf-cm, 61 ft-lbf)**

## 3. INSTALL DUST COVER

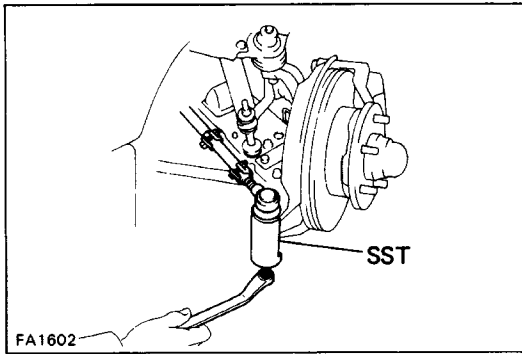

## Lower Suspension Arm and Shock Absorber

(See page SA-17)

### REMOVAL OF LOWER SUSPENSION ARM AND SHOCK ABSORBER

1. REMOVE TORSION BAR SPRING (See page SA-20)

2. DISCONNECT TIE ROD END

- (a) Remove the cotter pin and nut.
- (b) Using SST, disconnect the tie rod end.  
SST 09610-20012

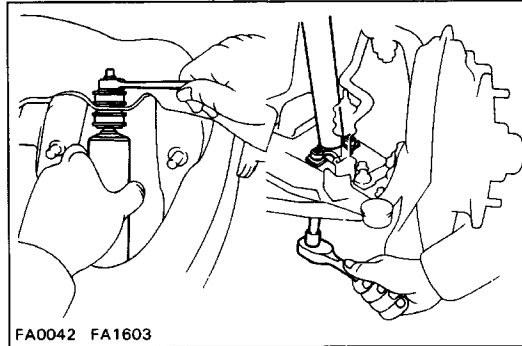

3. REMOVE SHOCK ABSORBER

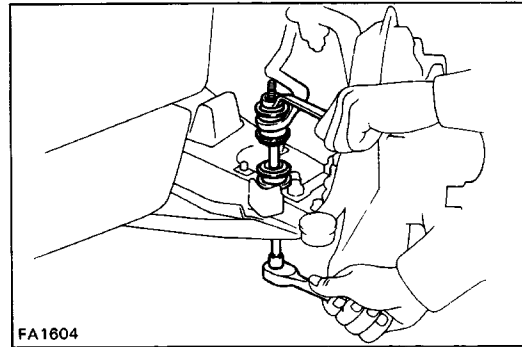

4. DISCONNECT STABILIZER BAR FROM LOWER ARM

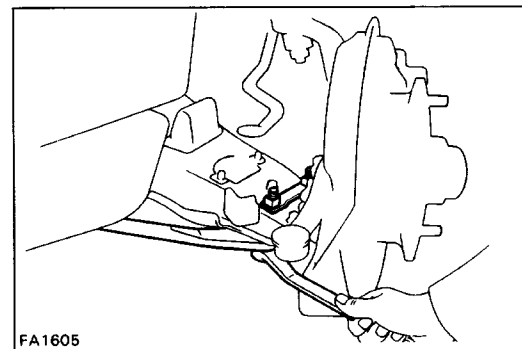

5. DISCONNECT STRUT BAR FROM LOWER ARM

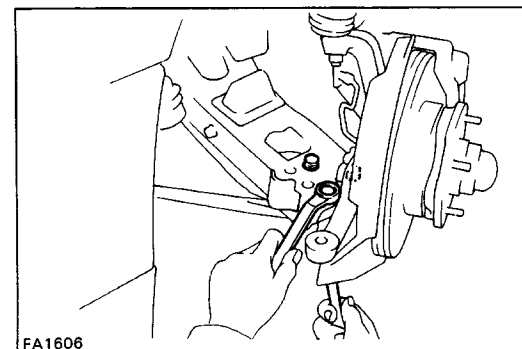

6. DISCONNECT LOWER BALL JOINT

Remove the three bolts and disconnect the lower ball joint.

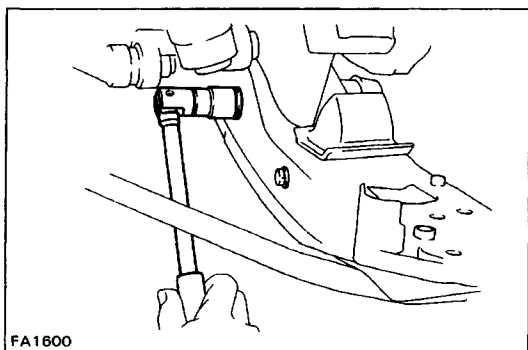

## 7. REMOVE LOWER SUSPENSION ARM

Remove the nut and lower suspension arm.

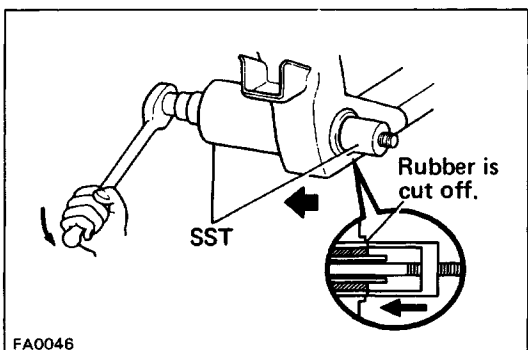

## REPLACEMENT OF LOWER ARM BUSHING

### 1. REMOVE BUSHING

(a) Cut off the bushing rubber as shown in the figure.

(b) Using SST, remove the bushing.

SST 09726-35010

### 2. INSTALL BUSHING

(a) Apply soapy water on the front rubber part of the bushing and fit SST on the new bushing.

SST 09726-35010

(b) Using SST, install the new bushing.

SST 09726-35010

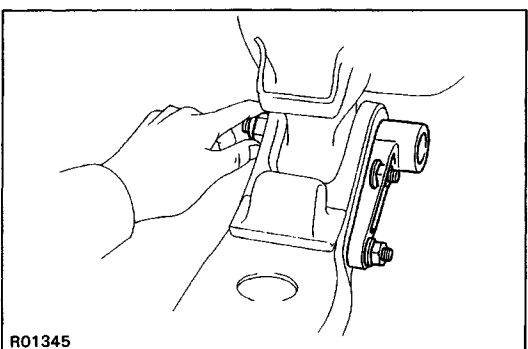
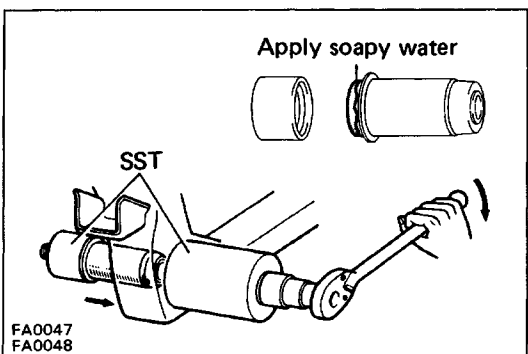

## INSTALLATION OF LOWER SUSPENSION ARM AND SHOCK ABSORBER

### 1. INSTALL LOWER SUSPENSION ARM

(a) Install the torque arm mounting bolts to the lower arm.

(b) Place the torque arm on the lower arm shaft.

Set the lower arm in installation position, and install the lower arm shaft and torque arm.

(c) Temporarily install the torque arm.

(d) Finger tighten the lower arm, and remove the torque arm.

HINT: Do not torque the nut.

### 2. CONNECT LOWER BALL JOINT

Connect the lower ball joint to the lower suspension arm with the three bolts.

Torque: 127 N-m (1,300 kgf-cm, 94 ft-lbf)

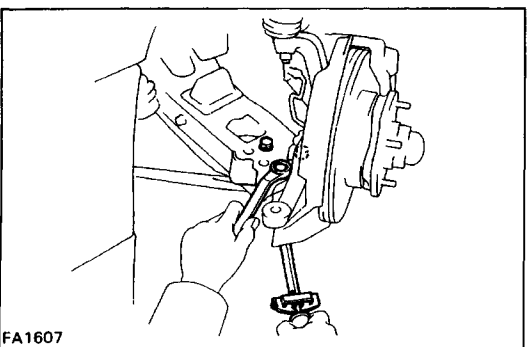

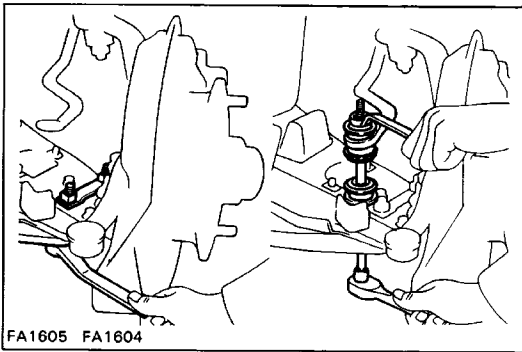
**3. CONNECT STRUT BAR TO LOWER ARM**

Torque: 95 N-m (970 kgf-cm, 70 ft-lbf)

**4. CONNECT STABILIZER BAR TO LOWER SUSPENSION ARM**

Torque: 13 N-m (130 kgf-cm, 9 ft-lbf)

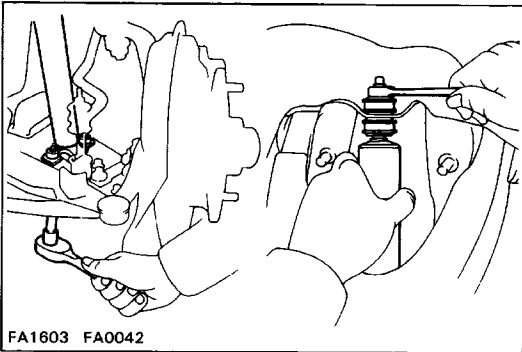
**5. INSTALL SHOCK ABSORBER**

- (a) Install the shock absorber to the lower suspension arm.

Torque: 18 N-m (185 kgf-cm, 13 ft-lbf)

- (b) Install the shock absorber to the upper bracket.

Torque: 25 N-m (250 kgf-cm, 18 ft-lbf)

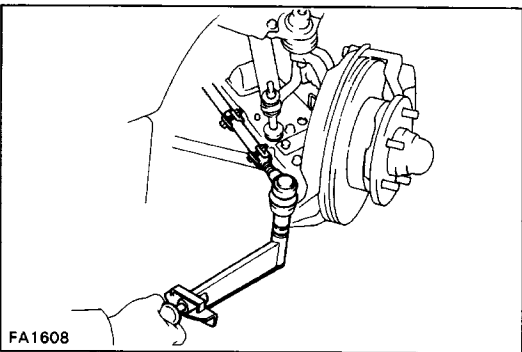
**6. CONNECT TIE ROD END**

- (a) Connect the tie rod end to the steering knuckle arm and install and torque the nut.

Torque: 90 N-m (920 kgf-cm, 67 ft-lbf)

- (b) Secure the nut with a new cotter pin.

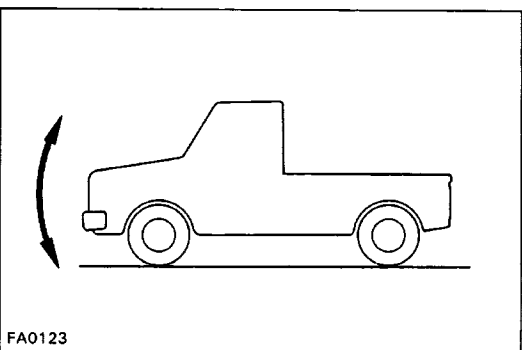
**7. INSTALL TORSION BAR SPRING**(See page [SA-20](#))**8. TORQUE LOWER SUSPENSION ARM SHAFT NUT**

- (a) Install the wheel.

- (b) Remove the stands and bounce the vehicle up and down to stabilize the suspension.

- (c) Torque the nut.

Torque: 226 N-m (2,300 kgf-cm, 166 ft-lbf)

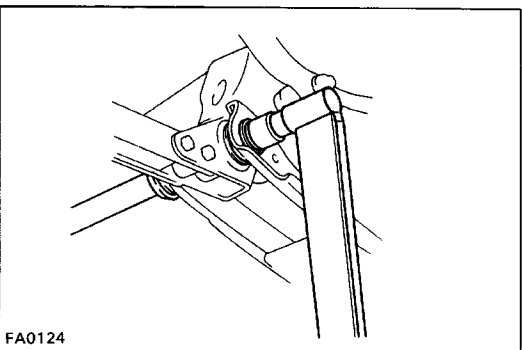
**9. CHECK FRONT WHEEL ALIGNMENT**(See page [SA-3](#))



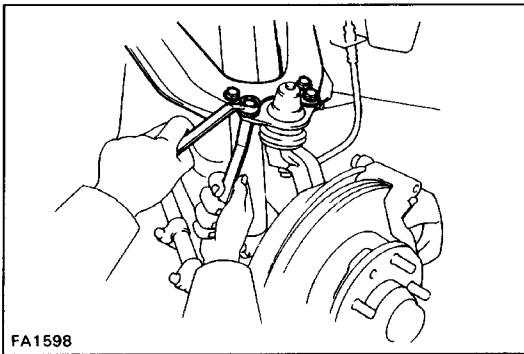

FA1598

## Upper Suspension Arm

(See page SA-17)

### REMOVAL OF UPPER SUSPENSION ARM

#### 1. DISCONNECT UPPER BALL JOINT FROM UPPER ARM

- (a) Support the lower arm with a jack.
- (b) Remove the four bolts and nuts, and disconnect the upper arm.

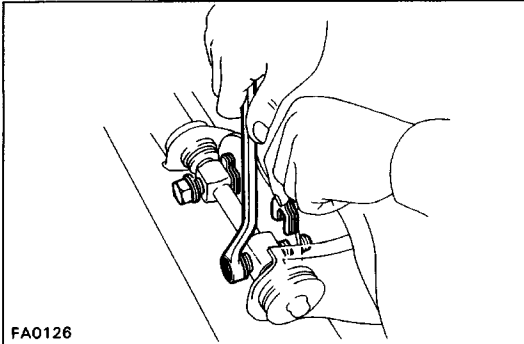

FA0126

#### 2. REMOVE UPPER SUSPENSION ARM

- (a) Remove the bolts and camber adjusting shims.
- (b) Remove the upper arm.
 

HINT: Do not loose the camber adjusting shims. Record the position, and the thickness of camber adjusting shims so that these can be reinstalled to their original location.

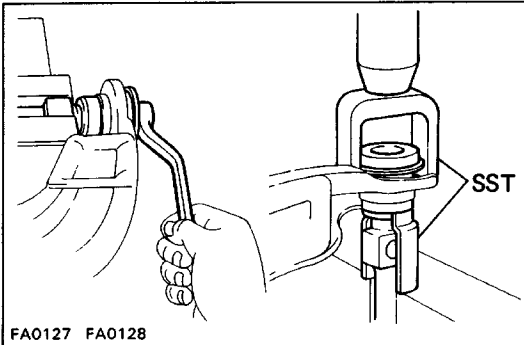

FA0127 FA0128

### REPLACEMENT OF UPPER ARM BUSHING

#### 1. REMOVE BUSHING

- (a) Remove the bolts and washers.
- (b) Using SST, push out the bushings.
 

SST 09710-30020 (09710-03030, 09710-03040)

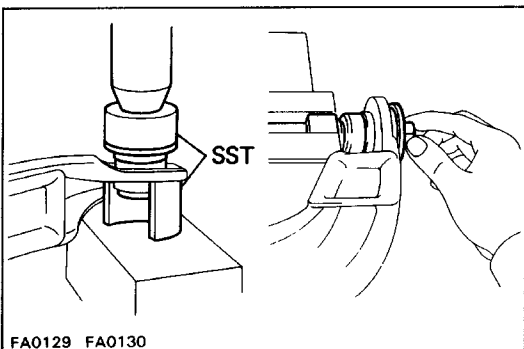

FA0129 FA0130

#### 2. INSTAL BUSHING

- (a) Using SST, push in the bushings.
 

SST 09710-30020 (09710-03060, 09710-03050)
- (b) Install the washers, and finger tighten the bolts.
 

HINT: Do not torque the bolts.

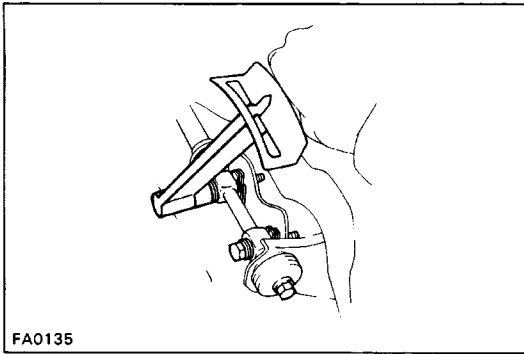

FA0135

## INSTALLATION OF UPPER SUSPENSION ARM

### 1. INSTALL UPPER ARM

- (a) Install the upper arm together with the camber adjusting shims.
- (b) Torque the bolts.

**Torque: 96 N-m (980 kgf-cm, 71 ft-lbf)**

**HINT:** Install an equal number and thickness of shims in their original position.

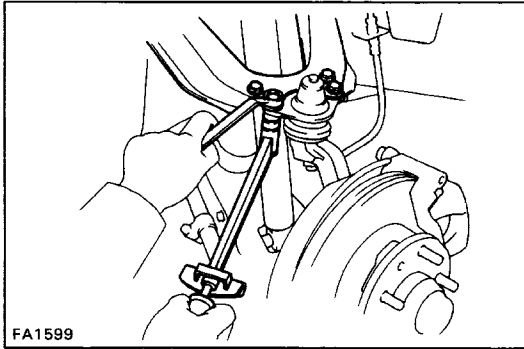

FA1599

### 2. CONNECT UPPER ARM

Connect the upper arm with the four bolts and nuts.

**Torque: 31 N-m (320 kgf-cm, 23 ft-lbf)**

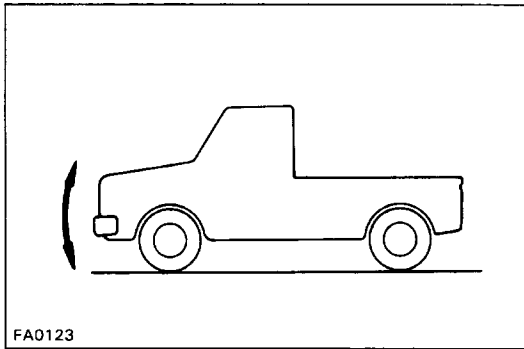

FA0123

### 3. TORQUE UPPER ARM SHAFT BOLTS

- (a) Install the wheel.
- (b) Remove the stands and bounce the vehicle up and down to stabilize the suspension.

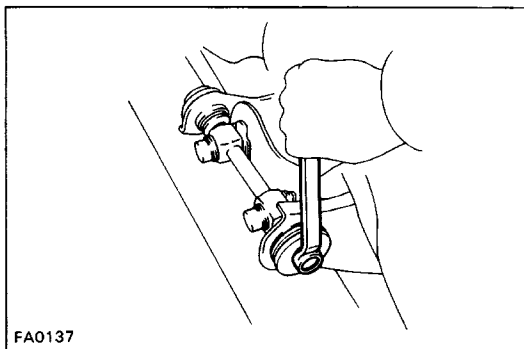

FA0137

- (c) Torque the upper arm shaft bolts.

**Torque: 126 N-m (1,280 kgf-cm, 93 ft-lbf)**

### 4. CHECK FRONT WHEEL ALIGNMENT

(See page [SA-3](#))

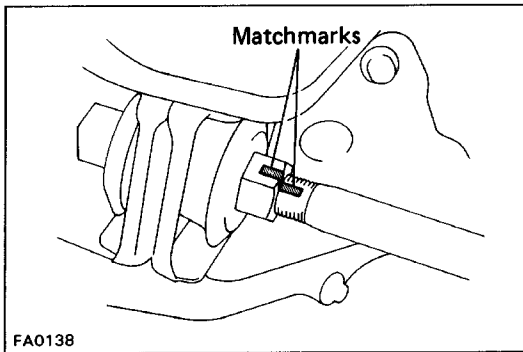

## Strut Bar

(See page SA-17)

### REMOVAL OF STRUT BAR

#### 1. PLACE MATCHMARKS ON STRUT BAR

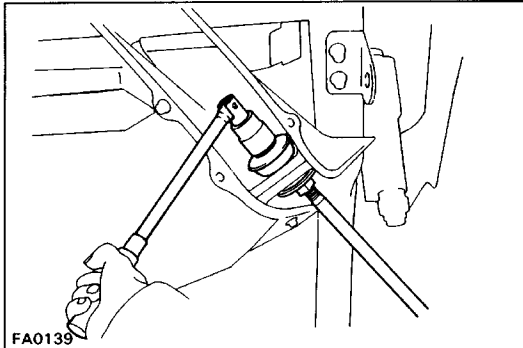

#### 2. REMOVE FRONT NUT FROM STRUT BAR

#### 3. REMOVE STRUT BAR FROM LOWER ARM

Remove the nuts holding the strut bar to the lower arm, and remove the strut bar.

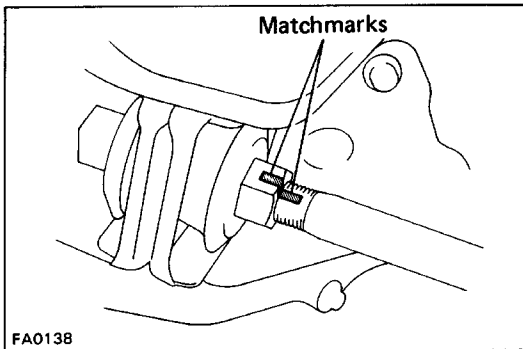

### INSTALLATION OF STRUT BAR

#### 1. INSTALL FRONT NUT

Install the front nut and align the matchmarks on the strut bar.

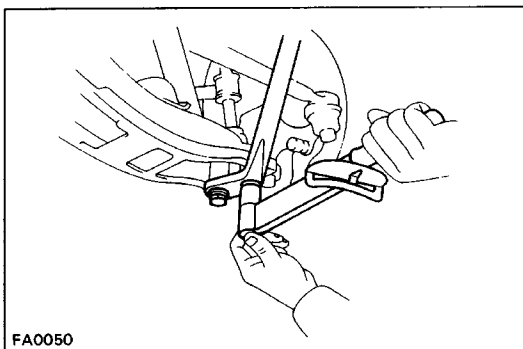

#### 2. INSTALL STRUT BAR TO BRACKET

(a) Install the washer and bushing to the strut bar and install it to the bracket.

(b) Install the collar, bushing and washer to the strut bar.

(c) Finger tighten the front nut.

#### 3. CONNECT STRUT BAR TO LOWER ARM

Torque: 95 N-m (970 kgf-cm, 70 ft-lbf)

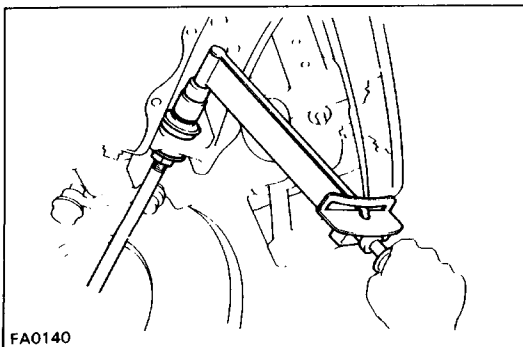

#### 4. TORQUE FRONT NUT

(a) Remove the stands and the vehicle to stabilize the suspension.

(b) Torque the front nut.

Torque: 123 N-m (1,250 kgf-cm, 90 ft-lbf)

#### 5. CHECK FRONT WHEEL ALIGNMENT

(See page SA-3)

## Stabilizer Bar

(See page [SA-17](#))

### REMOVAL OF STABILIZER BAR

#### 1. REMOVE ONE TORSION BAR SPRING

(See page [SA-20](#))

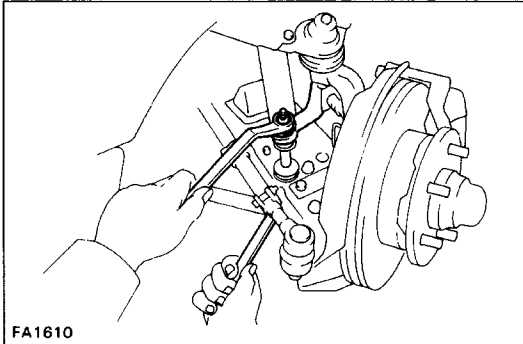

#### 2. REMOVE STABILIZER BAR FROM LOWER ARMS

(a) Remove the nuts and cushions holding both sides of the stabilizer bar from the lower arms, and disconnect the stabilizer bar.

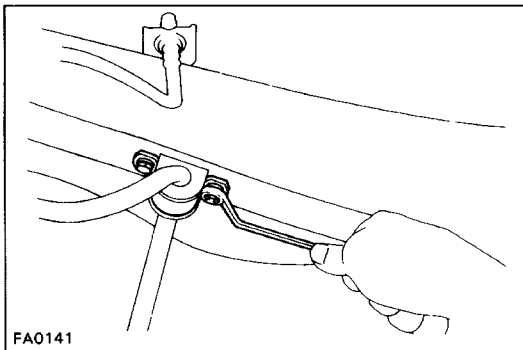

(b) Remove both stabilizer bar bushings and brackets, and remove the stabilizer bar.

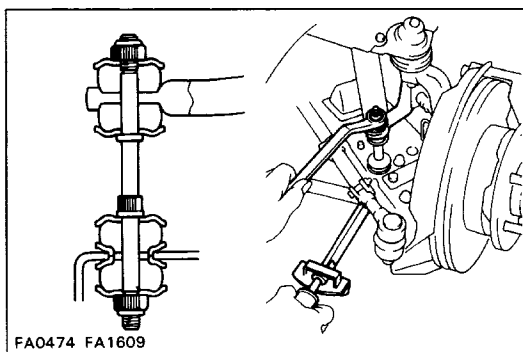

### INSTALLATION OF STABILIZER BAR

#### 1. PLACE STABILIZER BAR TO FRAME

Place the stabilizer bar in position and install both stabilizer bar bushings and brackets to the frame.

Finger tighten the bolts.

#### 2. CONNECT STABILIZER BAR TO LOWER ARMS

Connect the stabilizer bar on both sides to the lower arms with bolts, cushions and new nuts as shown. Torque the nuts.

Torque: 13 N-m (130 kgf-cm, 9 ft-lbf)

#### 3. TORQUE BRACKET SET BOLTS

Torque: 29 N-m (300 kgf-cm, 22 ft-lbf)

#### 4. INSTALL TORSION BAR SPRING

(See page [SA-20](#))

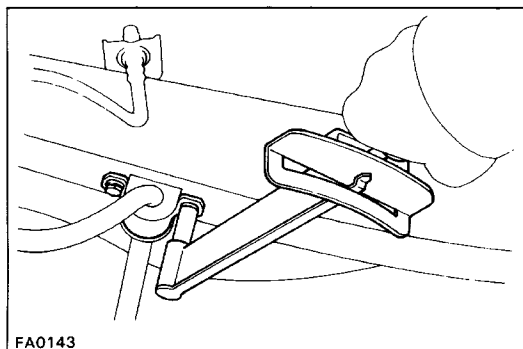

# FREE WHEELING HUB COMPONENTS

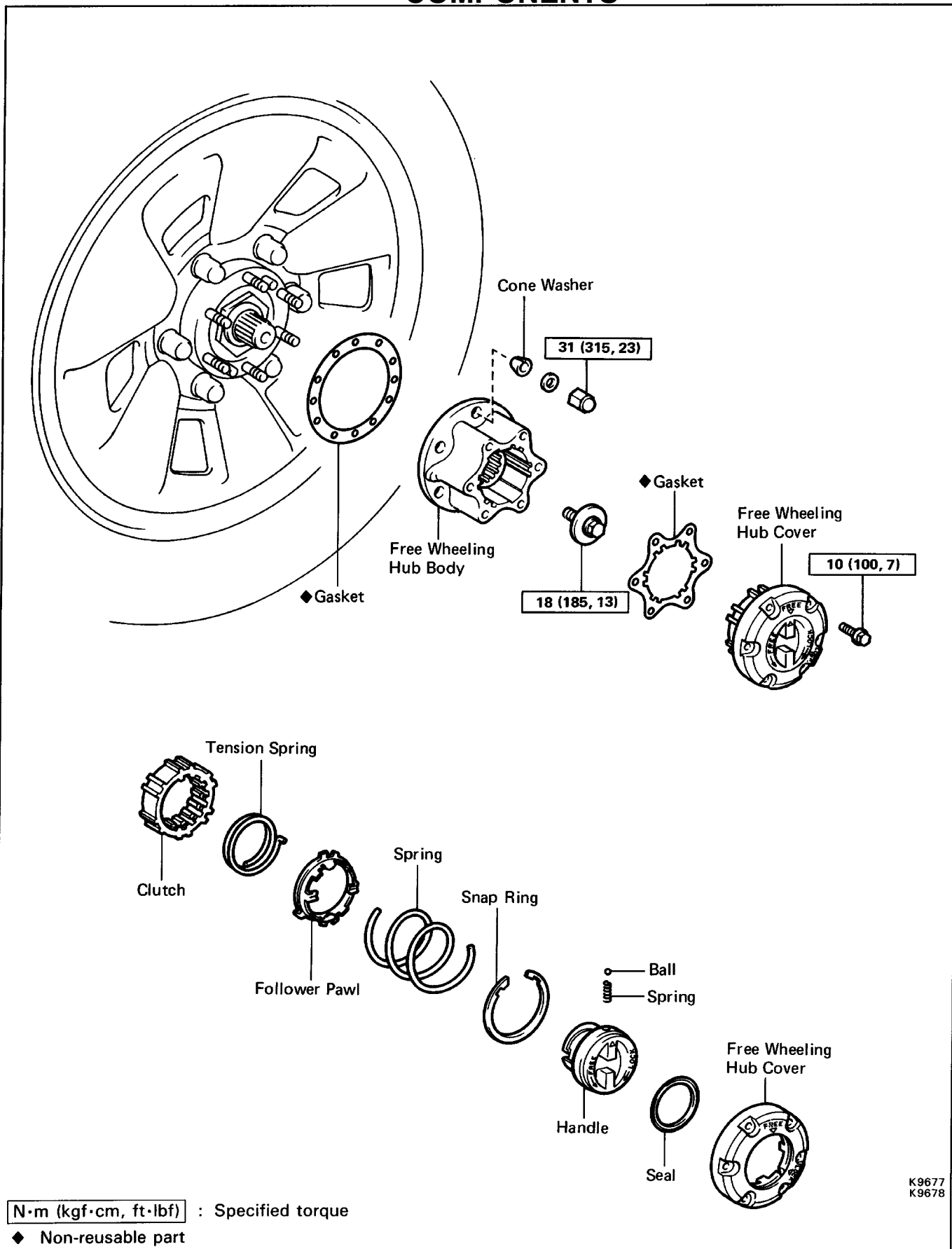

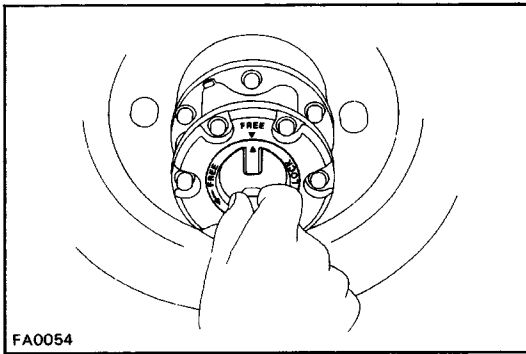

FA0054

## REMOVAL OF FREE WHEELING HUB

### 1. REMOVE FREE WHEELING HUB COVER

(a) Set the control handle to FREE.

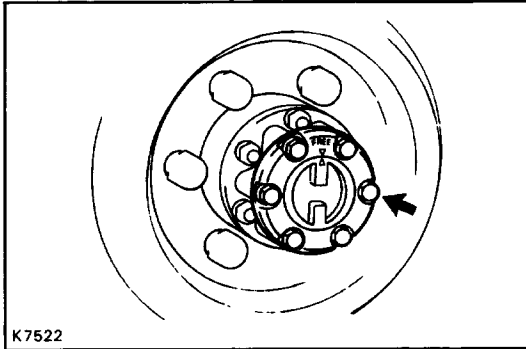

K7522

(b) Remove the cover mounting bolts and pull off the cover.

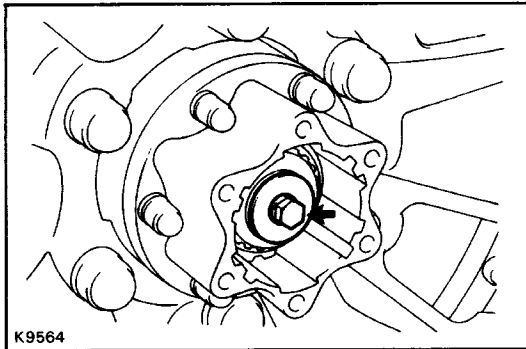

K9564

### 2. REMOVE BOLT WITH WASHER

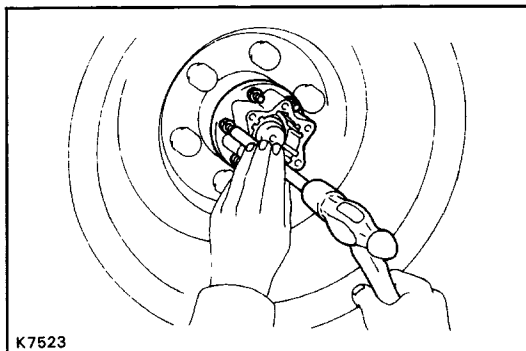

K7523

### 3. REMOVE FREE WHEELING HUB BODY

(a) Remove the mounting nuts and washers.

(b) Using a brass bar and hammer, tap on the bolts head and remove the cone washers.

(c) Pull off the free wheeling hub body.

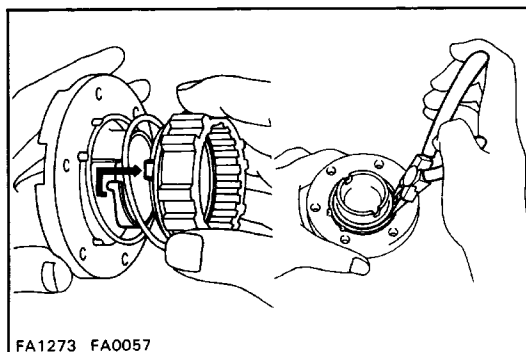

FA1273 FA0057

## DISASSEMBLY OF FREE WHEELING HUB

### 1. REMOVE CONTROL HANDLE FROM FREE WHEELING HUB COVER

(a) Compressing the spring, remove the pawl tab from the handle cam, and remove the clutch.

(b) Using snap ring pliers, remove the snap ring.

(c) Remove the control handle.

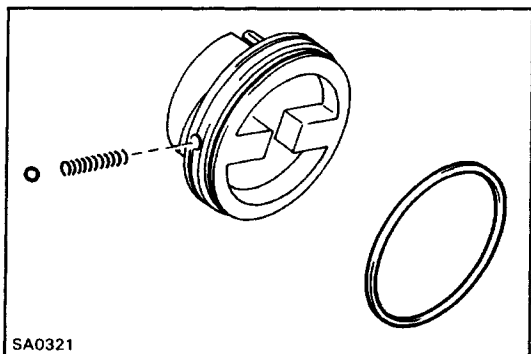

- (d) Remove the steel ball, spring and seal from the control handle.

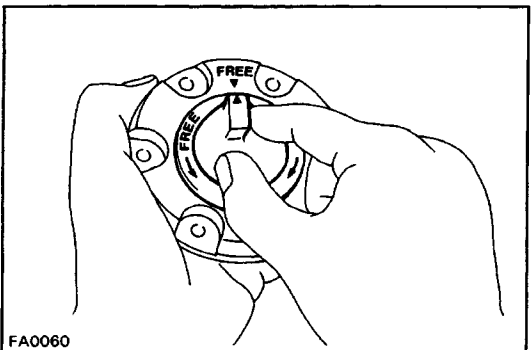

## INSPECTION OF FREE WHEELING HUB

### 1. INSPECT COVER, HANDLE AND SEAL

Temporarily install the handle in the cover and check that the handle moves smoothly and freely.

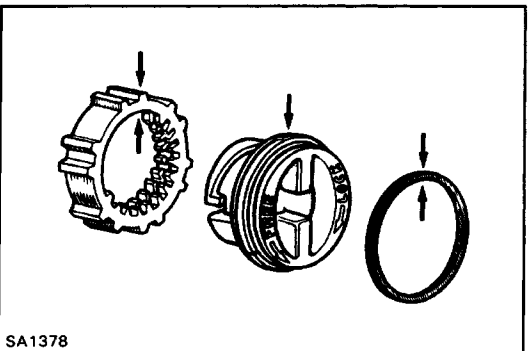

## ASSEMBLY OF FREE WHEELING HUB

### 1. APPLY MP GREASE TO SLIDING SURFACE OF PARTS

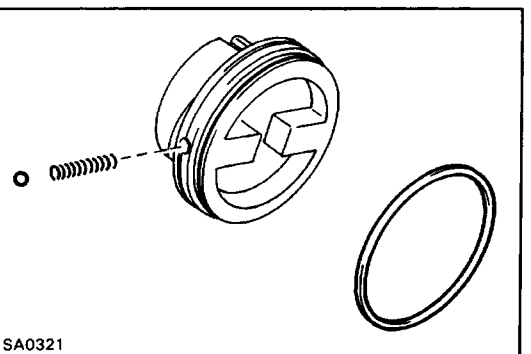

### 2. INSTALL CONTROL HANDLE TO COVER

- (a) Install the seal, spring and steel ball to the handle.

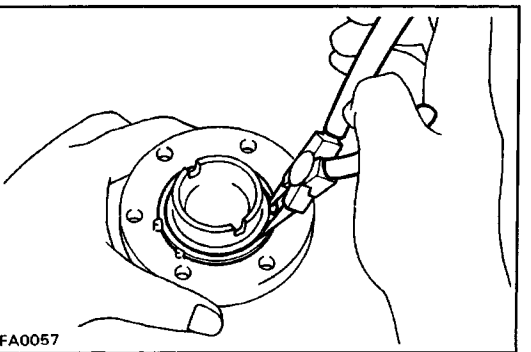

- (b) Install the handle in the cover and install the snap ring with snap ring pliers.

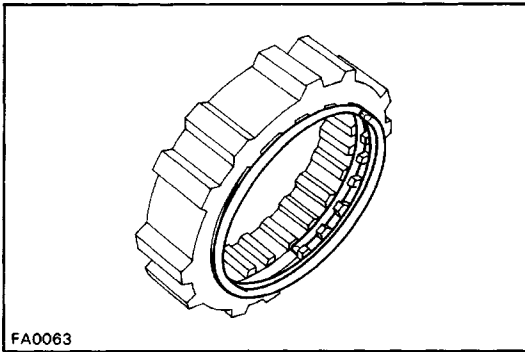

### 3. INSTALL TENSION SPRING IN CLUTCH

Install the tension spring in the clutch with the spring end aligned with the initial groove.

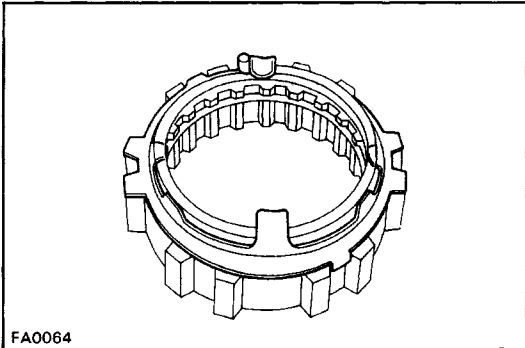

### 4. INSTALL FOLLOWER PAWL TO CLUTCH

- (a) Place the follower pawl on the tension spring with one of the large tabs against the bent spring end.
- (b) Place the top ring of the spring on the small tabs.

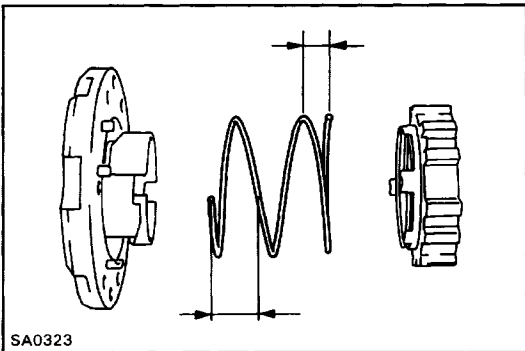

### 5. INSTALL CLUTCH AND SPRING INTO COVER

- (a) Place the spring between the cover and clutch with the large spring end toward the cover.

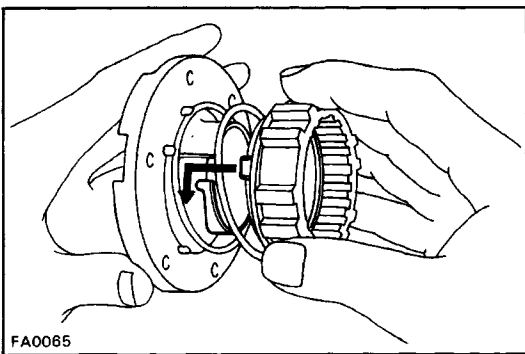

- (b) Compress the spring and install the clutch with the pawl tab fit to the handle cam.

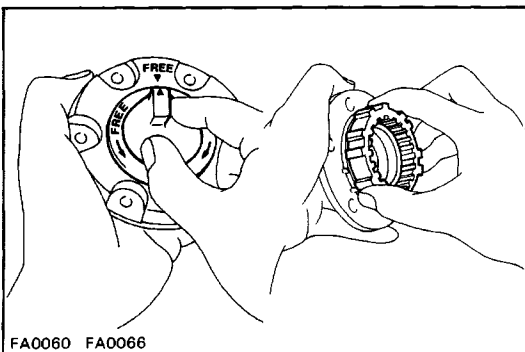

### 6. TEMPORARILY INSTALL COVER TO BODY AND CHECK FREE WHEELING HUB

- (a) Set the control handle and clutch to the FREE position.



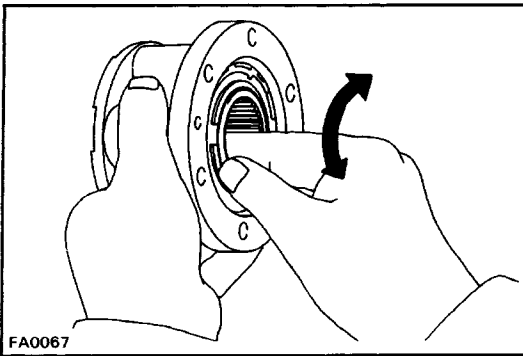

- (b) Insert the cover in the body and verify that the inner hub turns smoothly.
- (c) Remove the cover from the body.

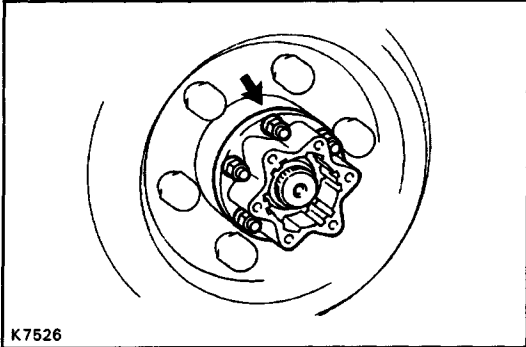

## INSTALLATION OF FREE WHEELING HUB

### 1. INSTALL FREE WHEELING HUB BODY

- (a) Place a new gasket in position on the front axle hub.
- (b) Install the free wheeling hub body with six cone washers and nuts. Tighten the nuts.  
Torque: 31 N-m (315 kgf-cm, 23 ft-lbf)

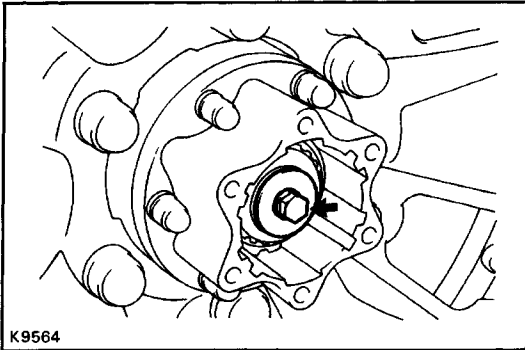

### 2. INSTALL BOLT WITH WASHER

Torque: 18 N-m (185 kgf-cm, 13 ft-lbf)

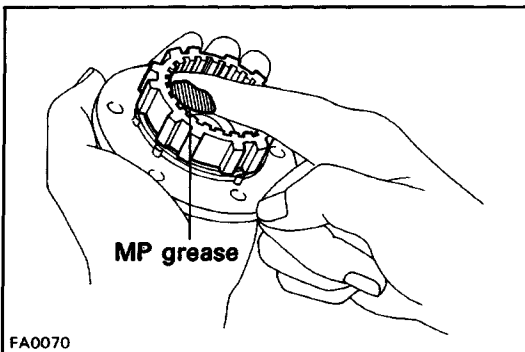

### 3. APPLY MP GREASE TO INNER HUB SPLINES

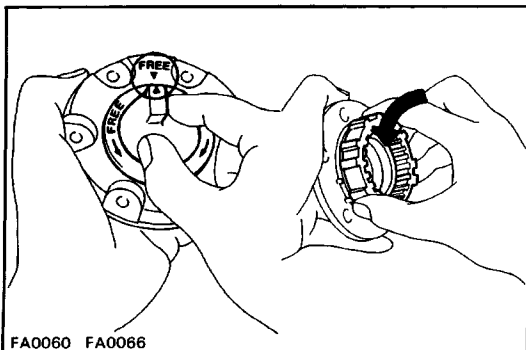

### 4. INSTALL FREE WHEELING HUB COVER WITH NEW GAS-KET

- (a) Set the control handle and clutch to the FREE position.
- (b) Place a new gasket in position on the cover.

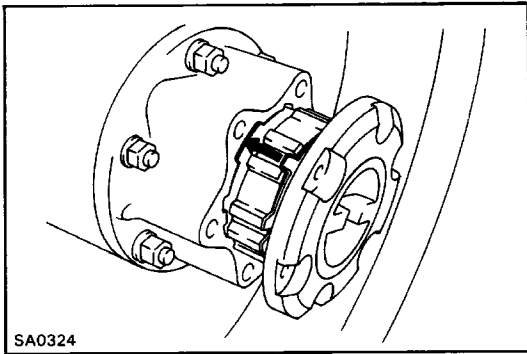

- (c) Install the cover to the body with the follower pawl tabs aligned with the non-toothed portions of the body.

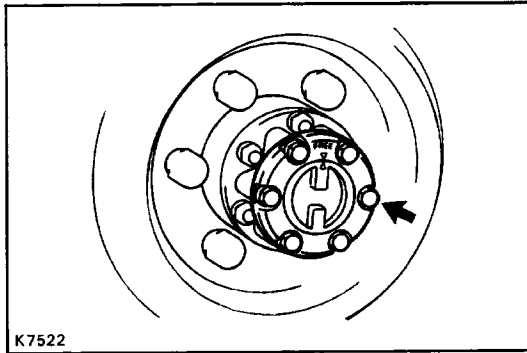

- (d) Tighten the cover mounting bolts.  
**Torque: 10 N-m (100 kgf-cm, 7 ft-lbf)**

# FRONT AXLE HUB AND STEERING KNUCKLE COMPONENTS

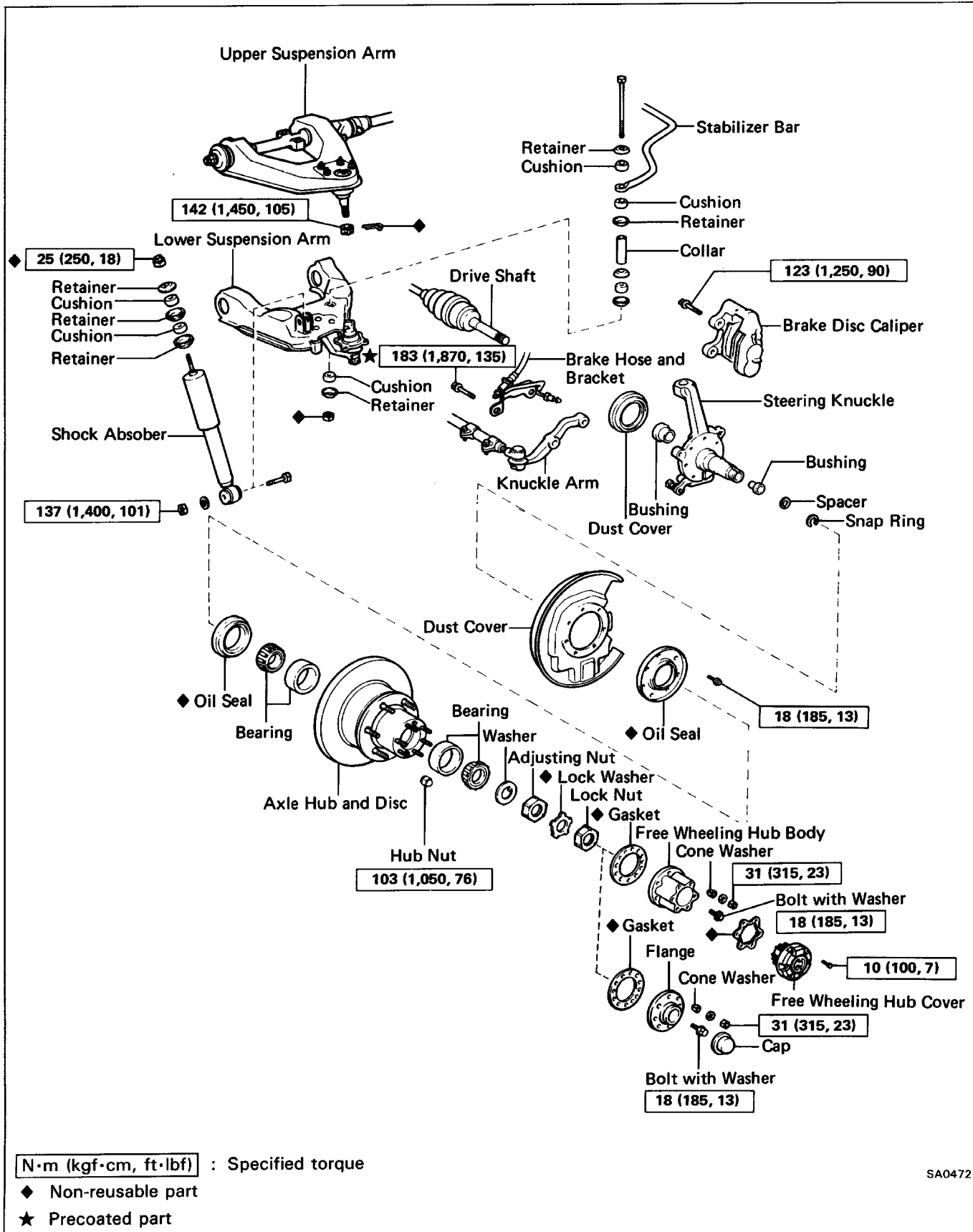

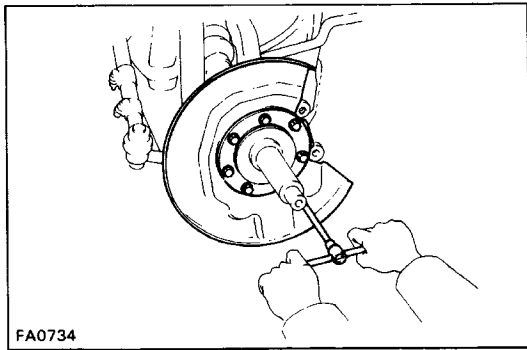

FA0734

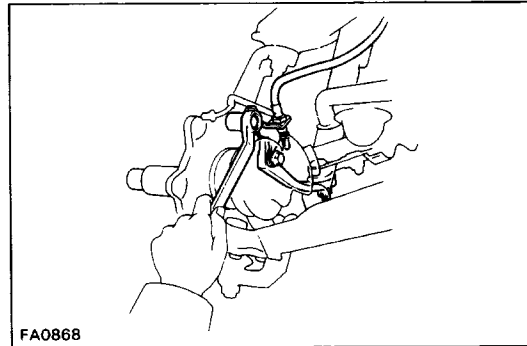

FA0868

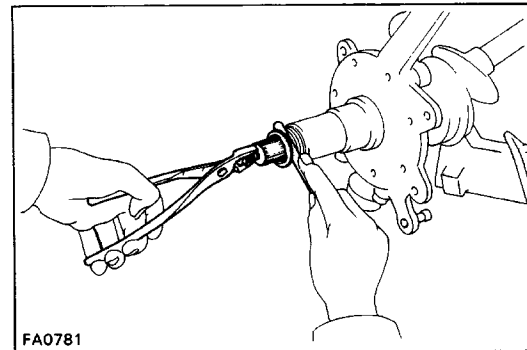

FA0781

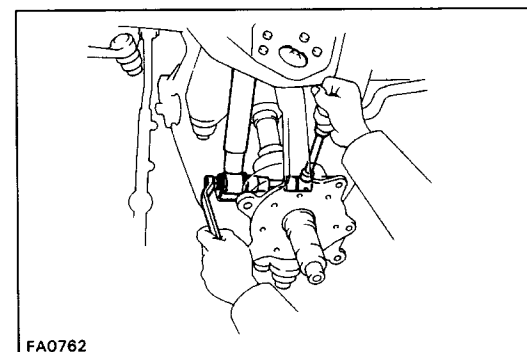

FA0762

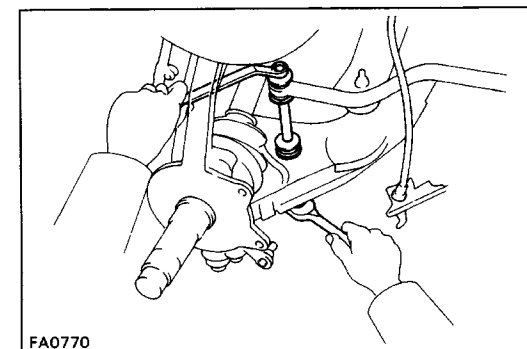

FA0770

## Steering Knuckle

(See page SA-35)

### REMOVAL OF STEERING KNUCKLE

#### 1. REMOVE DISC BRAKE CYLINDER AND FRONT AXLE HUB

(See page SA-36)

#### 2. REMOVE DUST COVER AND OIL SEAL

#### 3. DISCONNECT KNUCKLE ARM FROM STEERING KNUCKLE

#### 4. MEASURE STEERING KNUCKLE BUSHING THRUST CLEARANCE

- (a) Install a bolt in the drive shaft.
- (b) Using a feeler gauge, measure the front drive shaft thrust clearance between the steering knuckle outside bushing and spacer, by pulling the bolt and applying 98 N (10 kgf, 22.0 lbf) of pressure.

Front drive shaft thrust clearance:

Standard clearance      0.075 – 0.690 mm  
(0.0030 – 0.0272 in.)

Maximum clearance 1.0 mm (0.039 in.)

If the measurement more than maximum, replace the steering knuckle outside and inside bushings.

#### 5. DISCONNECT FRONT SHOCK ABSORBER FROM LOWER SUSPENSION ARM

#### 6. DISCONNECT STABILIZER BAR FROM LOWER SUSPENSION ARM

Remove the nut, bolt, retainers, cushions and collar, and disconnect the stabilizer bar from the lower suspension arm.

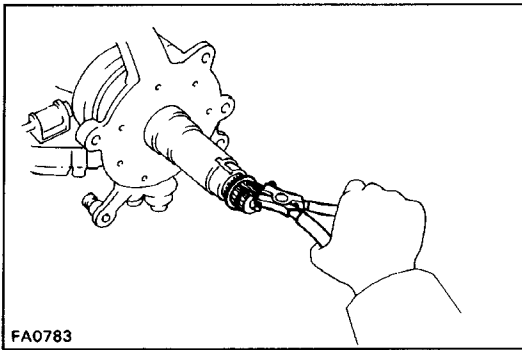

## 7. REMOVE SNAP RING AND SPACER

Using snap pliers, remove the snap ring and spacer.

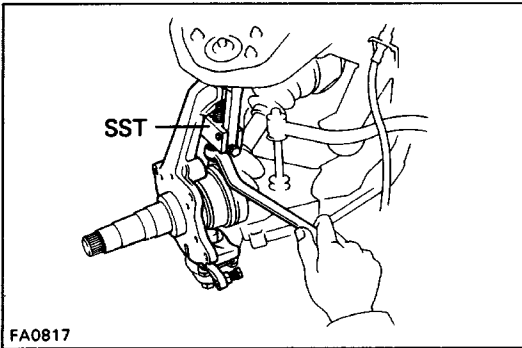

## 8. REMOVE STEERING KNUCKLE

- (a) Remove the cotter pin and nut from the upper ball joint.
- (b) Using SST, disconnect the steering knuckle from the upper ball joint.  
SST 09628-62011

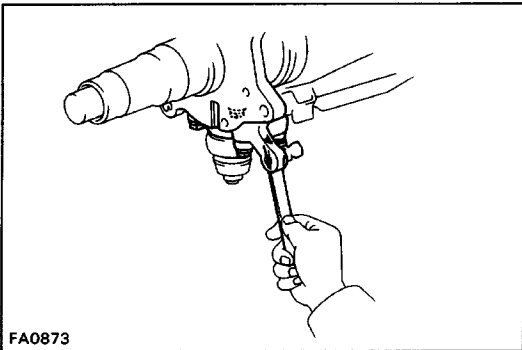

- (c) Remove the four bolts from the lower ball joint and disconnect the steering knuckle from the lower ball joint.

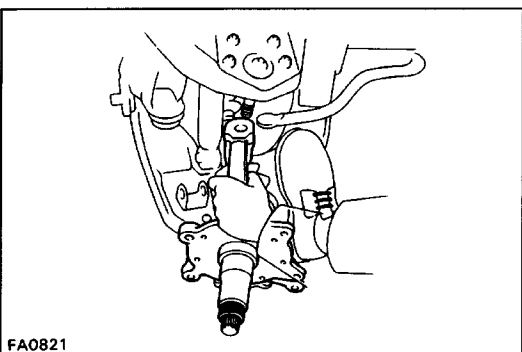

- (d) Push the lower suspension arm down and remove the steering knuckle.

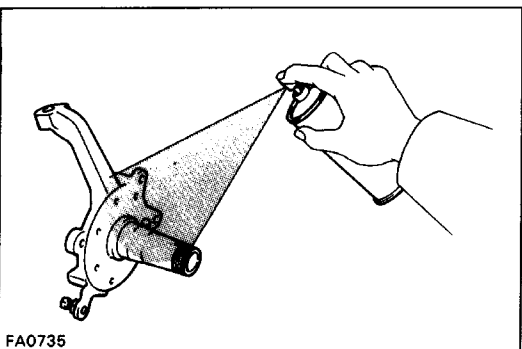

## INSPECTION AND REPLACEMENT OF STEERING KNUCKLE

### 1. INSPECT STEERING KNUCKLE

Using a dye penetrant, check the steering knuckle for cracks.

If crack is found, replace the steering knuckle.

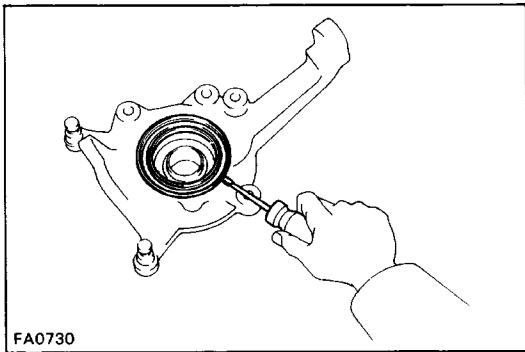

## 2. REMOVE DUST DEFLECTOR

Using a screwdriver, pry out the dust deflector from the steering knuckle.

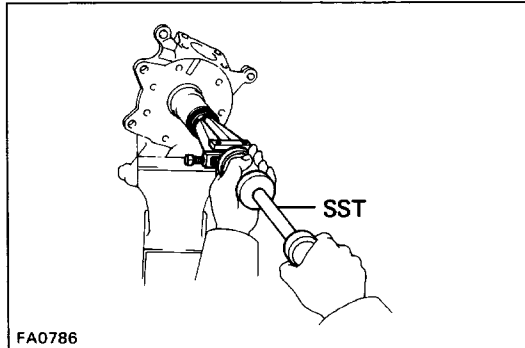

## 3. REMOVE STEERING KNUCKLE BUSHING

- (a) Using SST, pull out the steering knuckle outside bushing.  
SST 09308-00010

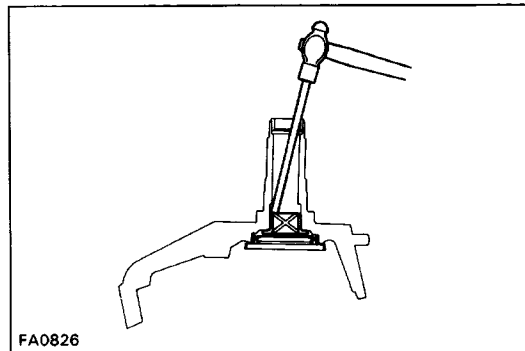

- (b) Using a brass bar and hammer, drive out the steering knuckle inside bushing.

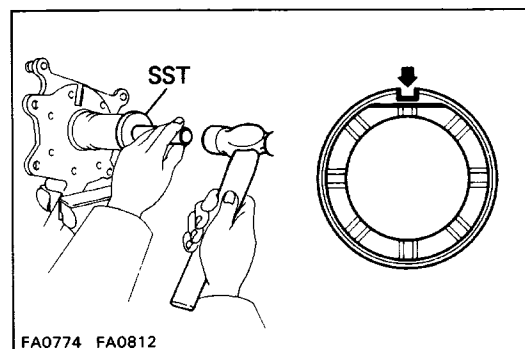

## 4. INSTALL STEERING KNUCKLE BUSHING

- (a) Using SST and a hammer, tap in a new steering knuckle outside bushing.  
SST 09550-10012 (09252-10010, 09555-10010)  
HINT: When installing the bushing to the spindle, make sure the flat portion of the bushing is aligned with the spindle groove as shown in the figure.

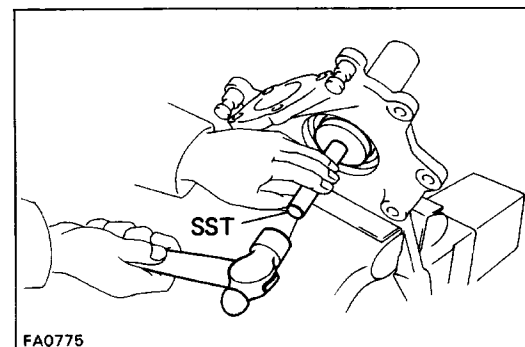

- (b) Using SST and a hammer, tap in a new steering knuckle inside bushing.  
SST 09550-10012 (09252-10010, 09555-10010)

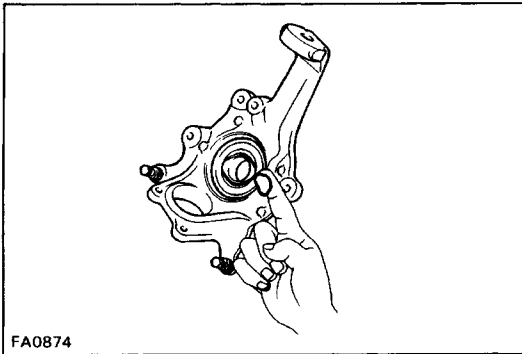

FA0874

- (c) Apply molybdenum disulphide lithium base grease to the steering knuckle bushings.

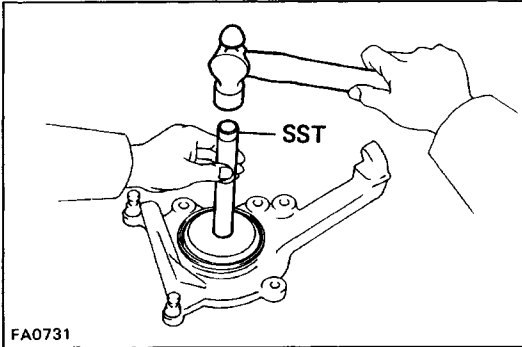

FA0731

## 5. INSTALL DUST DEFLECTOR TO STEERING KNUCKLE

Using SST and a hammer, tap in a new dust deflector.  
SST 09608-35014 (09608-06020, 09608-06180)

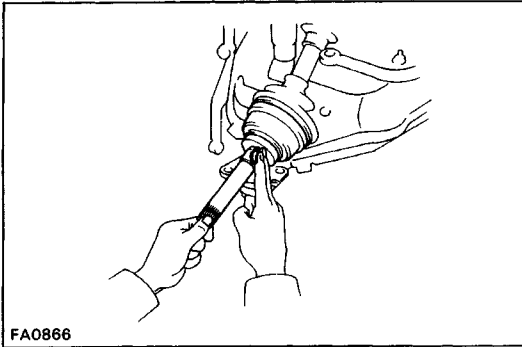

FA0866

## INSTALLATION OF STEERING KNUCKLE

(See page SA-35)

### 1. INSTALL STEERING KNUCKLE

- (a) Apply molybdenum disulphide lithium base grease to the drive shaft.

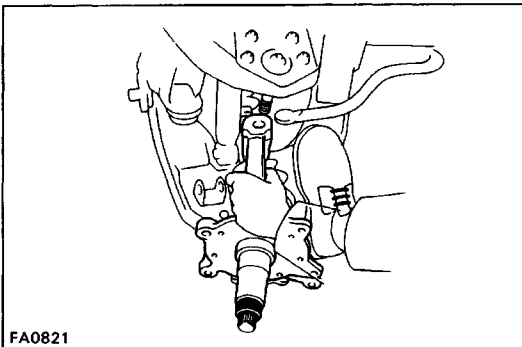

FA0821

- (b) Push the lower suspension arm down and install the steering knuckle.

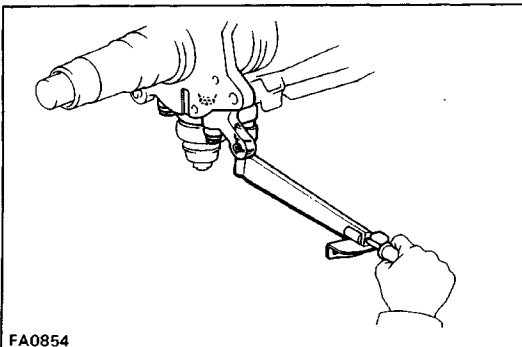

FA0854

- (c) Connect the lower ball joint to the steering knuckle and install and torque the four bolts.

**Torque: 58 N-m (590 kgf-cm, 43 ft-lbf)**

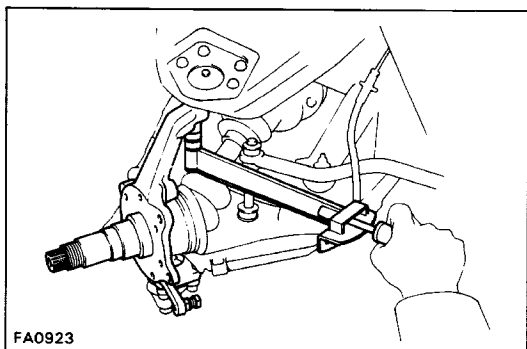

- (d) Connect the upper ball joint to the steering knuckle and install and torque the nut.  
**Torque: 142 N-m (1,450 kgf-cm, 105 ft-lbf)**
- (e) Install a new cotter pin.

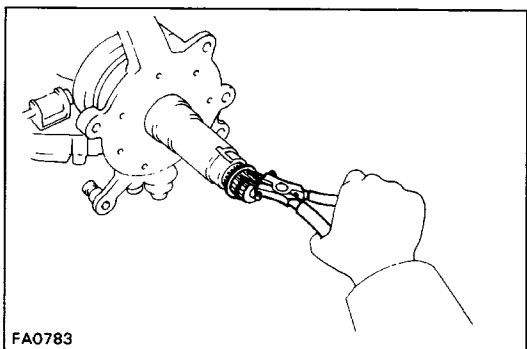

## 2. INSTALL SPACER AND SNAP RING

Install the spacer to the front drive shaft, and using snap ring pliers, install the snap ring.  
 If you replace the steering knuckle bushing, recheck the front drive shaft thrust clearance.

- (a) Install the bolt in the shaft.

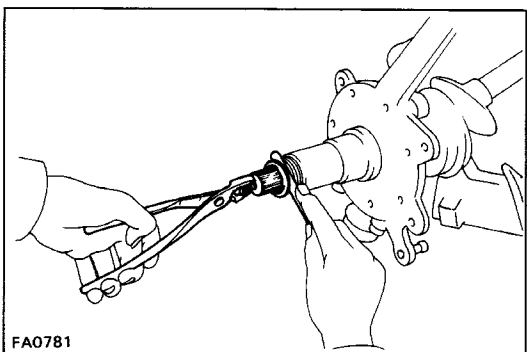

- (b) Using a feeler gauge, measure the front drive shaft thrust clearance between the steering knuckle outside bushing and spacer, by pulling the bolt and applying 98 IV (10 kgf, 22.0 lbf) of pressure.

**Front drive shaft thrust clearance:**

**Standard clearance    0.075 – 0.690 mm  
 (0.0030 – 0.0272 in.)**

If the clearance is not within specification, replace the spacer.    Spacer thickness

1.80 mm	(0.0709 in.)
2.25 mm	(0.0886 in.)

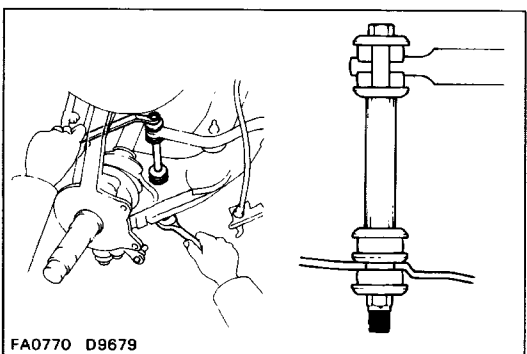

## 3. CONNECT STABILIZER BAR TO LOWER SUSPENSION ARM

Jack up the stabilizer bar and install the retainers, cushions and collar as shown in the figure, and torque the nut.  
**Torque: 25 N-m (260 kgf-cm, 19 ft-lbf)**

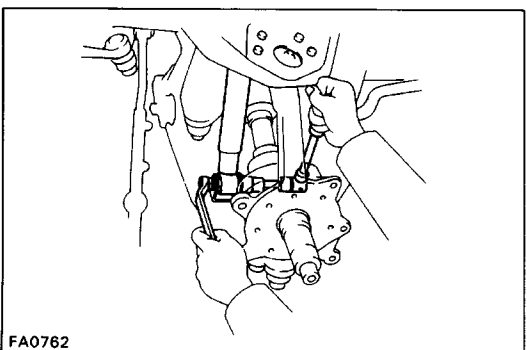

## 4. CONNECT FRONT SHOCK ABSORBER TO LOWER SUSPENSION ARM

**Torque: 137 N-m (1,400 kgf-cm, 101 ft-lbf)**



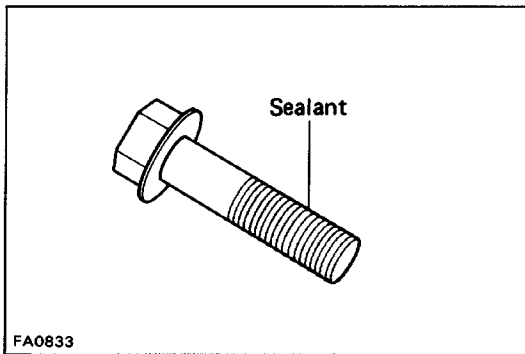

## 5. CONNECT KNUCKLE ARM TO STEERING KNUCKLE

(a) Clean the threads of the bolts and steering knuckle with toluene or trichloroethylene.

(b) Apply sealant to the bolt threads.

Sealant: Part No. 08833-00070, THREE BOND 1324 or equivalent.

(e) Connect the knuckle arm to the steering knuckle with brake hose bracket and torque bolts.

**Torque: 183 N-m (1,870 kgf-cm, 135 ft-lbf)**

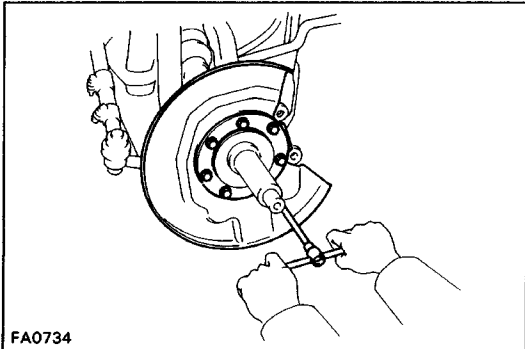

## 6. INSTALL DUST COVER AND NEW OIL SEAL

**Torque: 18 N-m (185 kgf-cm, 13 ft-lbf)**

## 7. INSTALL FRONT AXLE HUB AND DISC BRAKE CYLINDER

(See page [SA-37](#) )

## 8. BLEED BRAKE SYSTEM

# FRONT DRIVE SHAFT COMPONENTS

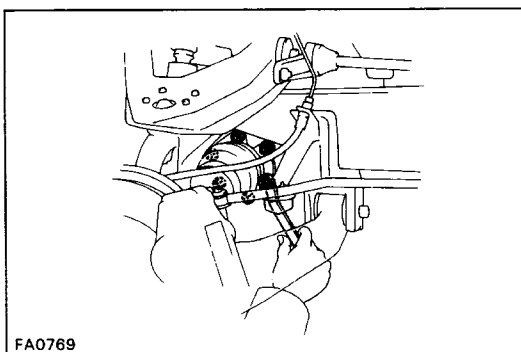
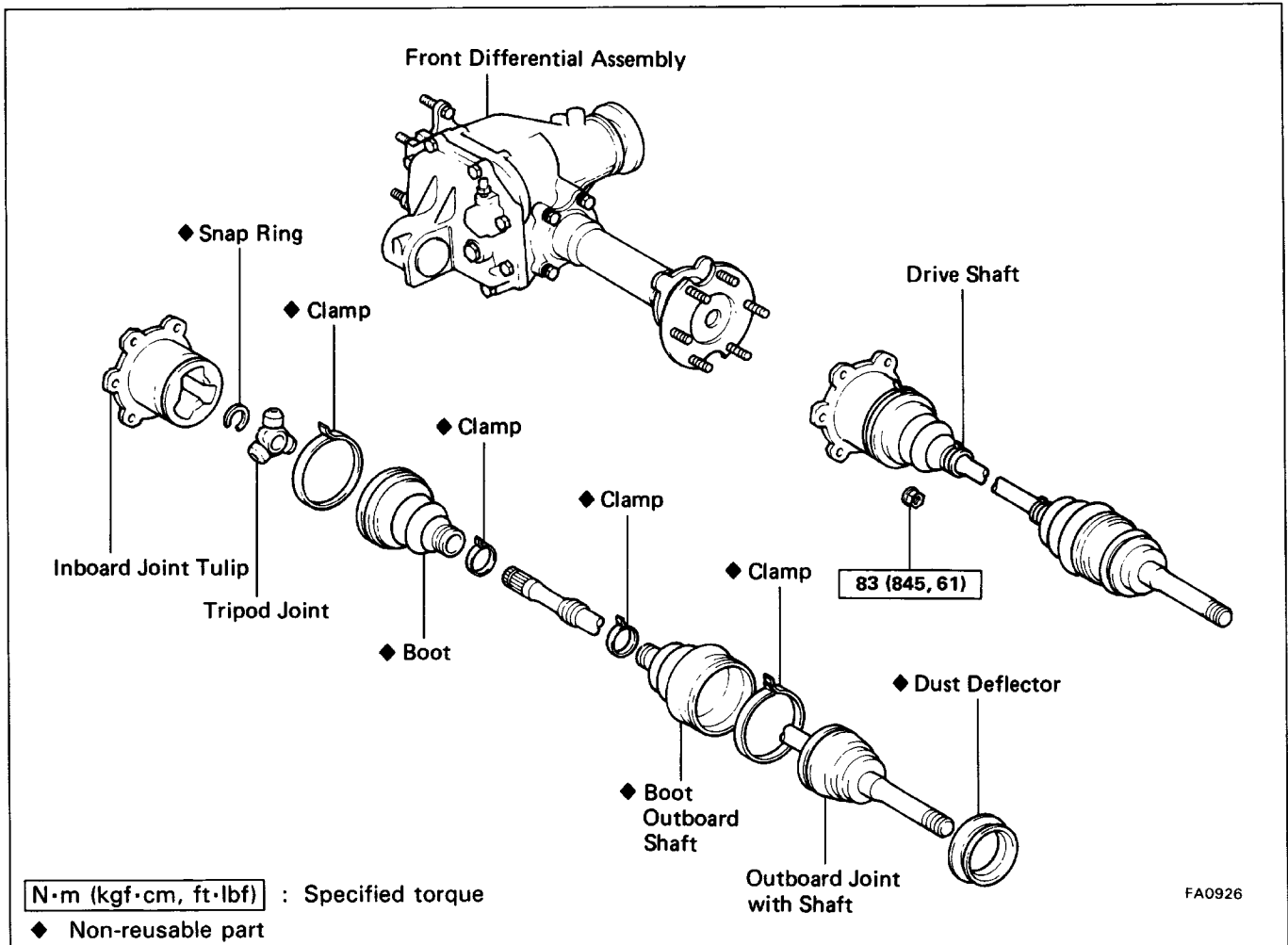

## REMOVAL OF FRONT DRIVE SHAFT

### 1. LOOSEN NUTS HOLDING FRONT DRIVE SHAFT

Loosen the six nuts, while depressing the brake pedal.

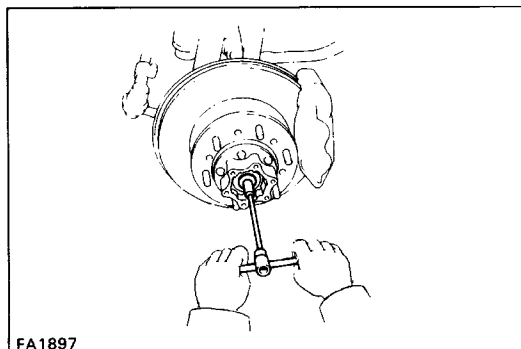

### 2. REMOVE FREE WHEELING HUB OR FLANGE

(Free wheeling hub See page SA-29)

(Flange See page SA-36)

### 3. REMOVE SNAP RING AND SPACER

Using a snap ring expander, remove the snap ring from the drive shaft.

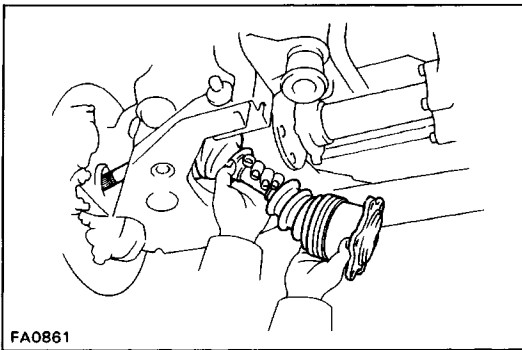

FA0861

#### 4. REMOVE FRONT DRIVE SHAFT

First pull the front drive shaft inboard joint tulip from the side gear shaft, and then pull it out from the steering knuckle.

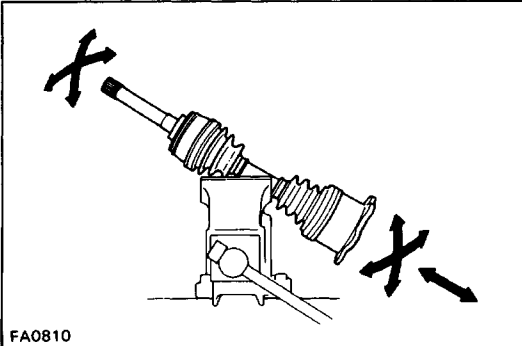

FA0810

#### DISASSEMBLY OF FRONT DRIVE SHAFT

##### 1. CHECK DRIVE SHAFT

- Check to see there is no play in the inboard and outboard joints.
- Check to see that the inboard joint slides smoothly in the thrust direction.
- Check to see that there is no noticeable play in the radial direction of the universal joints.
- Check for damage to the boots.

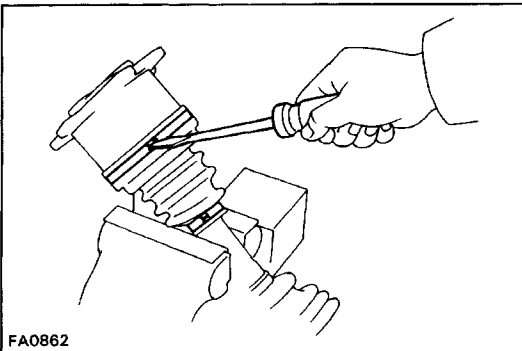

FA0862

##### 2. REMOVE INBOARD JOINT BOOT CLAMPS

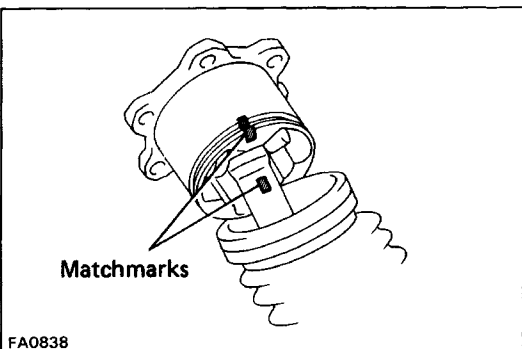

FA0838

##### 3. DISASSEMBLE INBOARD JOINT TULIP

- Place matchmarks on the inboard joint tulip and shaft.  
**NOTICE: Do not punch the marks.**
- Remove the inboard joint tulip from the drive shaft.

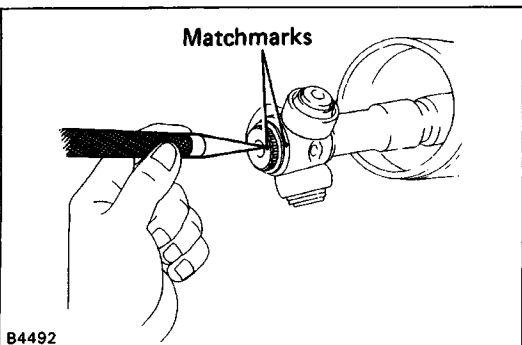

B4492

##### 4. DISASSEMBLE TRIPOD JOINT

- Using a snap ring expander, remove the snap ring.
- Using a punch and hammer, place matchmarks on the shaft and tripod.

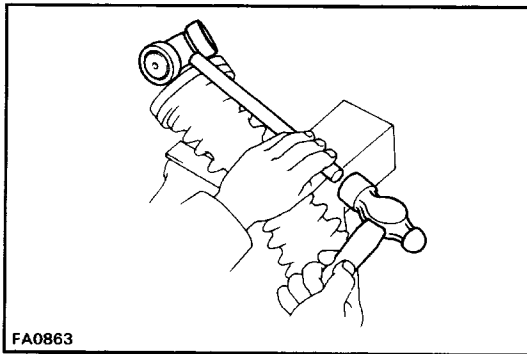

(c) Using a brass bar and hammer, remove the tripod joint from the drive shaft.

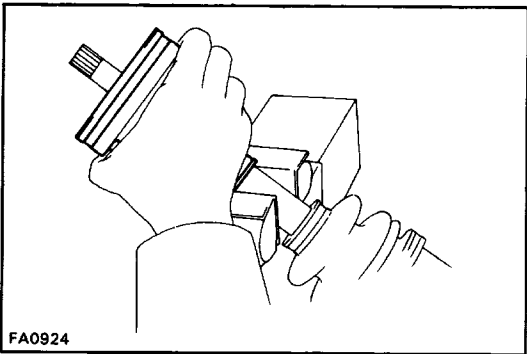

#### 5. REMOVE INBOARD JOINT BOOT

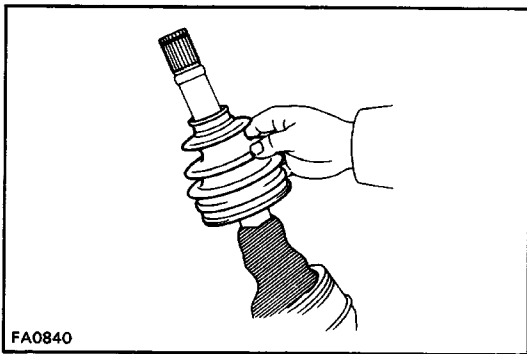

#### 6. REMOVE OUTBOARD JOINT BOOT CLAMPS AND BOOT

**NOTICE:** Do not disassemble the outboard joint.

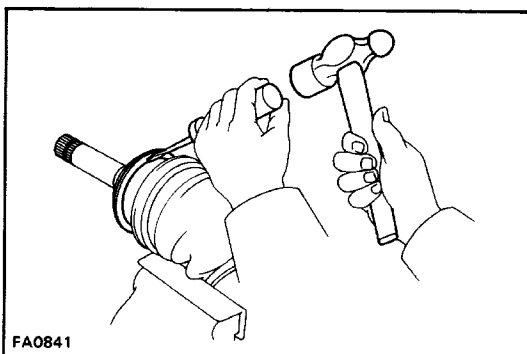

#### 7. REMOVE DUST DEFLECTOR

Using a screwdriver and hammer, remove the dust deflector.

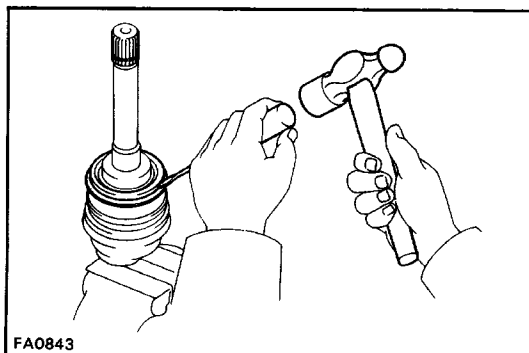

#### ASSEMBLY OF FRONT DRIVE SHAFT

(See page [SA-46](#))

#### 1. INSTALL DUST DEFLECTOR

Using a hammer and screwdriver, install a new dust deflector.

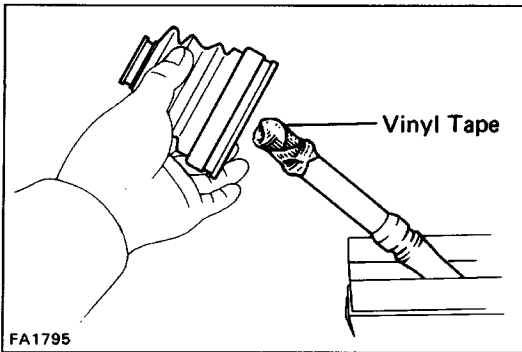

## 2. TEMPORARILY INSTALL BOOT AND NEW BOOT CLAMPS TO OUTBOARD JOINT

HINT: Before installing the boot, wrap vinyl tape around the spline of the shaft to prevent damaging the boot.

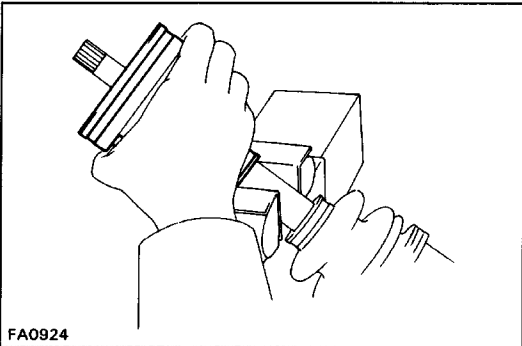

## 3. TEMPORARILY INSTALL BOOT AND NEW BOOT CLAMPS FOR INBOARD JOINT TO DRIVE SHAFT

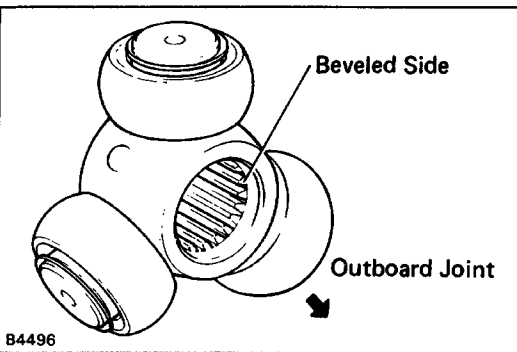

## 4. ASSEMBLE TRIPOD JOINT

(a) Place the beveled side of the tripod axial spline toward the outboard joint.

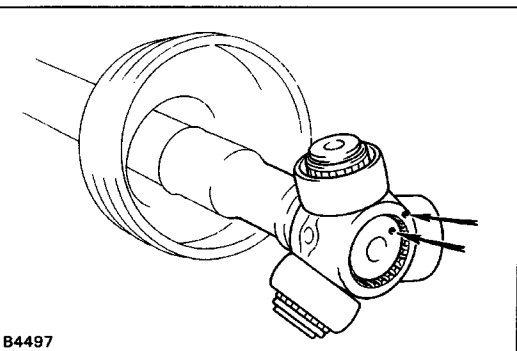

(b) Align the matchmarks placed before disassembly.

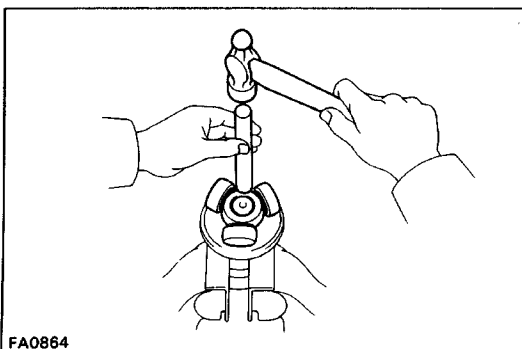

(e) Using a brass bar and hammer, tap in the tripod joint to the drive shaft.

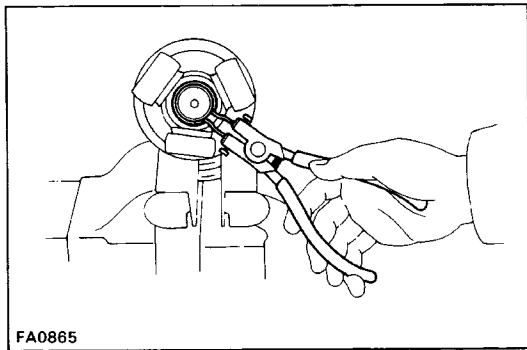

(d) Using a snap ring expander, install a new snap ring.

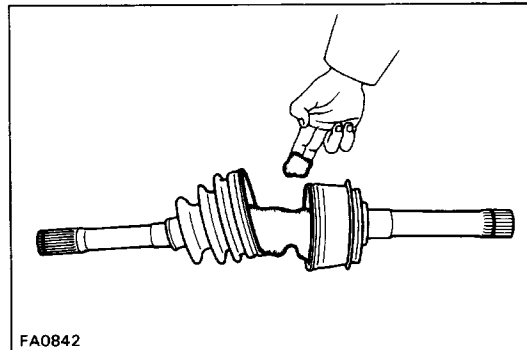

### 5. ASSEMBLE BOOT TO OUTBOARD JOINT

Before assembling the boot, pack in grease.

HINT: Use the grease (black) supplied in the boot kit.

**Grease capacity: 195 – 205 g (0.43 – 0.45 lb)**

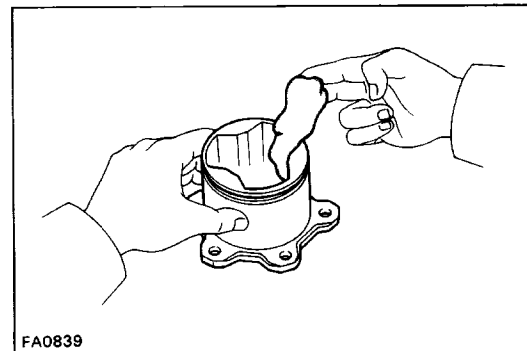

### 6. ASSEMBLE INBOARD JOINT TO INBOARD JOINT TULIP

(a) Pack in grease to the inboard tulip and boot.

HINT: Use the grease (brown) supplied in the boot kit.

**Grease capacity: 270 – 280 g (0.60 – 0.62 lb)**

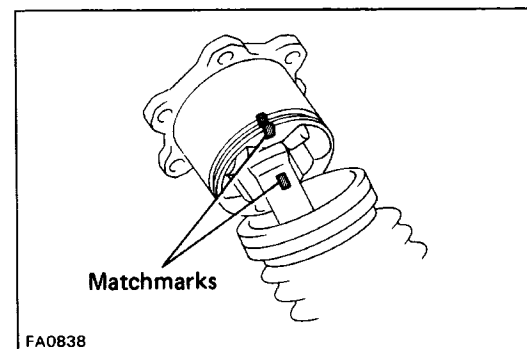

(b) Align the matchmarks placed before disassembly.

(c) Install the inboard tulip to the drive shaft.

(d) Temporarily install the boot to the inboard tulip.

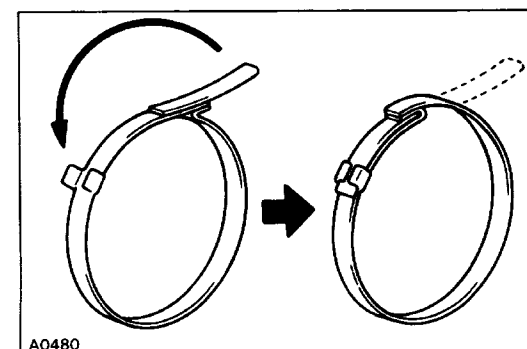

### 7. ASSEMBLE NEW BOOT CLAMPS TO BOTH BOOTS

(a) Be sure the boot is on the shaft groove.

(b) Bend the band and lock it as shown in the figure.

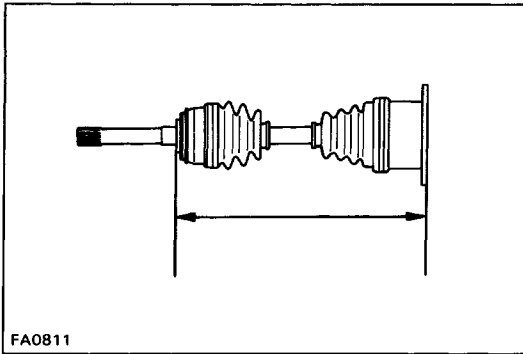

- (c) Insure that the boot is not stretched or contracted when the drive shaft is at standard length.

**Standard length:**

393.9 – 403.9 mm (15.508 – 15.902 in.)

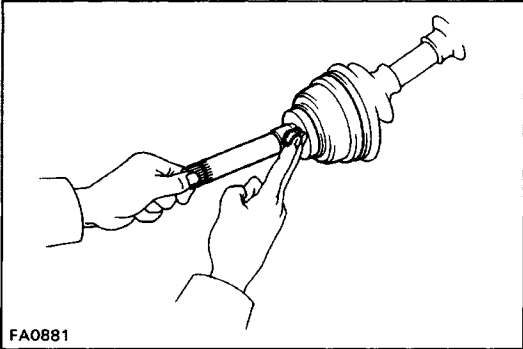

## INSTALLATION OF FRONT DRIVE SHAFT

(See page SA-46)

### 1. APPLY MOLYBDENUM DISULPHIDE LITHIUM BASE GREASE

Apply molibdenum disulphide lithium base grease to the outboard joint shaft.

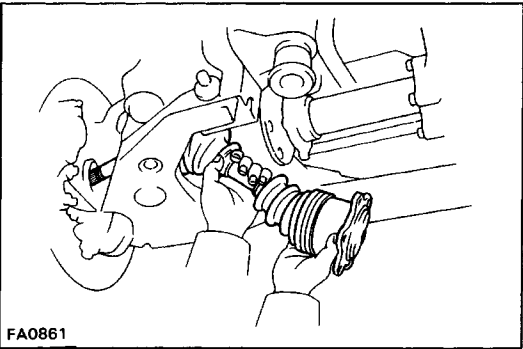

### 2. INSTALL FRONT DRIVE SHAFT

- (a) First insert the outboard joint shaft to the steering knuckle, and then install it to the side gear shaft.

HINT: Do not damage the boots.

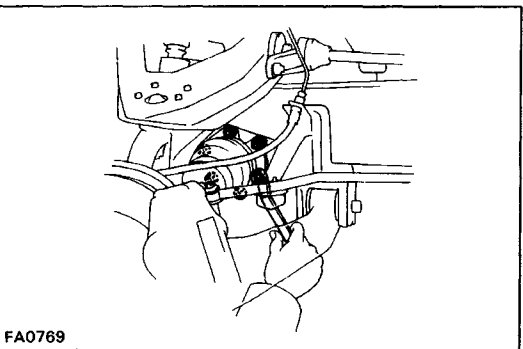

- (b) Temporarily install the six nuts.

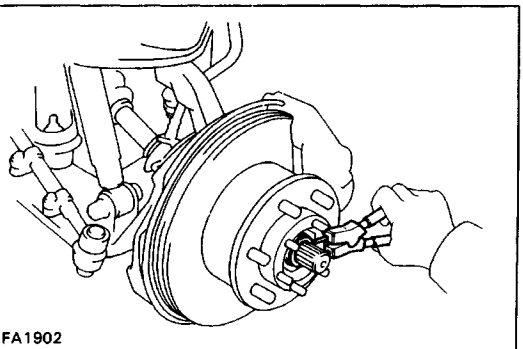

### 3. INSTALL SPACER AND SNAP RING

Install the spacer, and using a snap ring expander, install the snap ring to the outboard joint shaft.

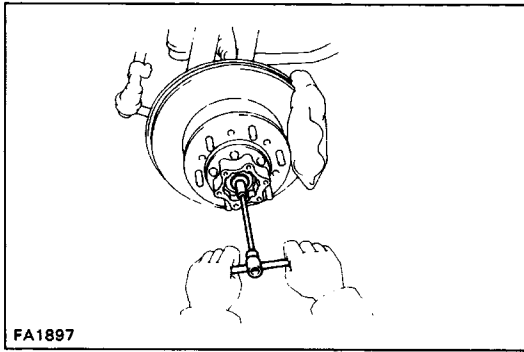

#### 4. INSTALL FREE WHEELING HUB OR FLANGE

(Free wheeling hub See page [SA-33](#))

(Flange See page [SA-39](#))

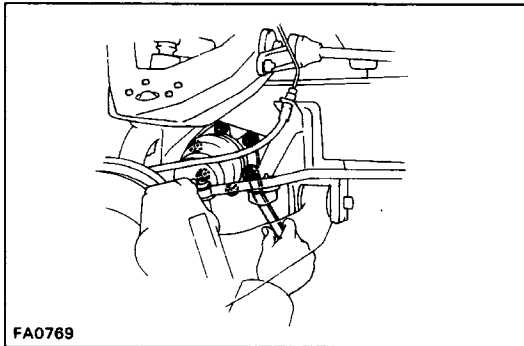

#### 5. TORQUE FRONT DRIVE SHAFT INSTALLATION NUTS

Torque the six nuts, while depressing the brake pedal.

**Torque: 83 N-m (845 kgf-cm, 61 ft-lbf )**



# FRONT DIFFERENTIAL

## On-Vehicle Replacement of Rear Oil Seal

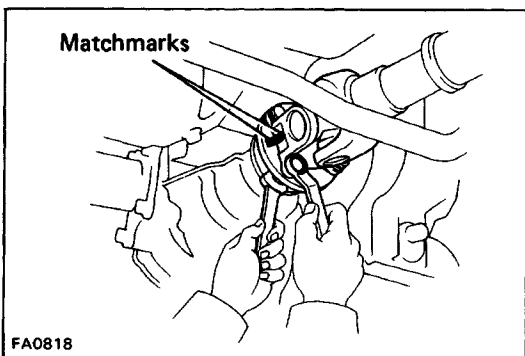
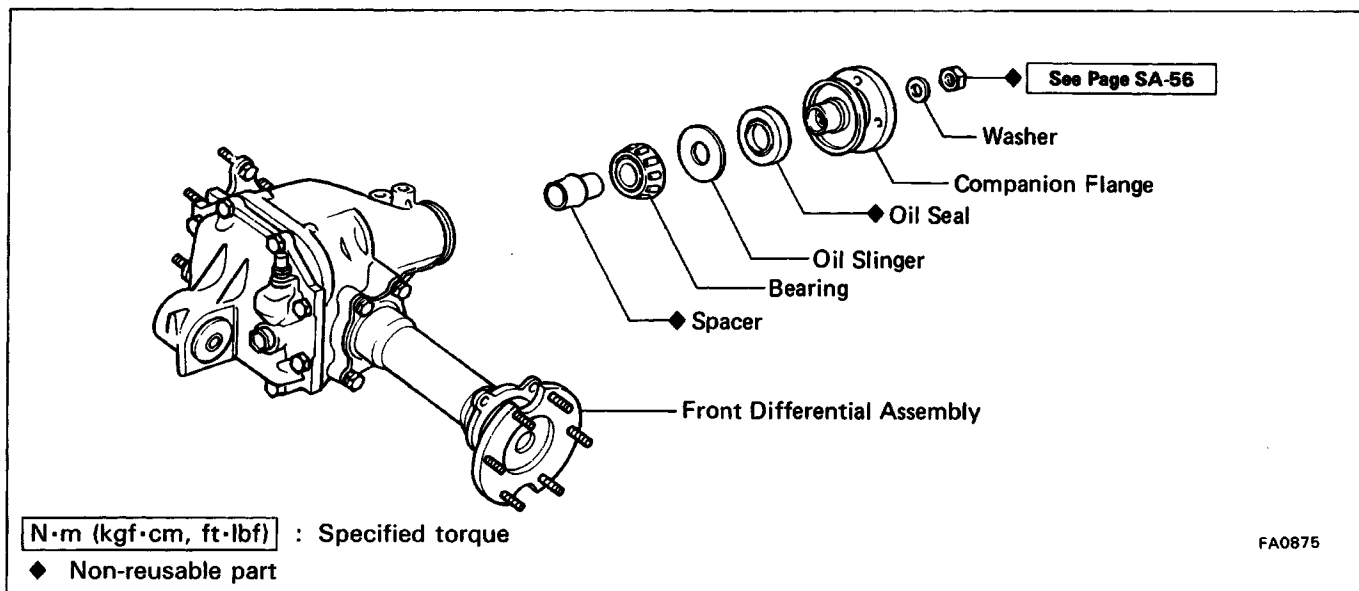

### 1. DRAIN DIFFERENTIAL OIL

### 2. DISCONNECT PROPELLER SHAFT

Before disconnecting the propeller shaft from the front differential, place matchmarks on them.

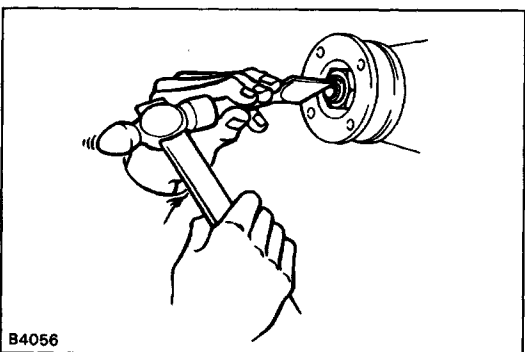

### 3. REMOVE COMPANION FLANGE

(a) Using a hammer and chisel, loosen the staked part of the nut.

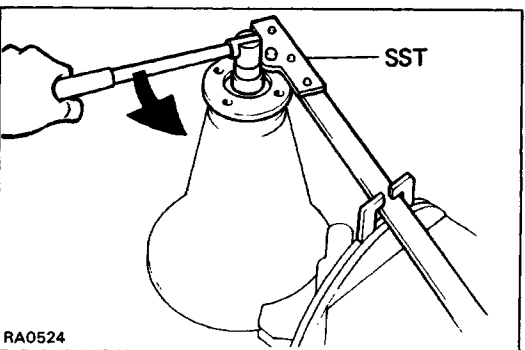

(b) Using SST to hold the flange, remove the nut and washer.  
SST 09330-00021

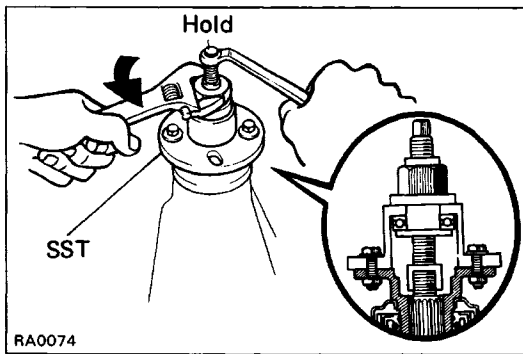

- (c) Using SST, remove the companion flange.  
SST 09557-22022 (09557-22030)

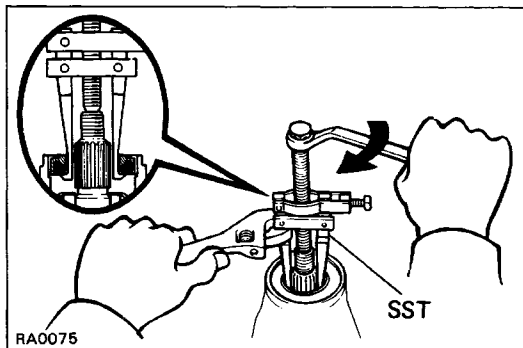

#### 4. REMOVE OIL SEAL AND OIL SLINGER

- (a) Using SST, remove the oil seal.  
SST 09308-10010
- (b) Remove the oil slinger.

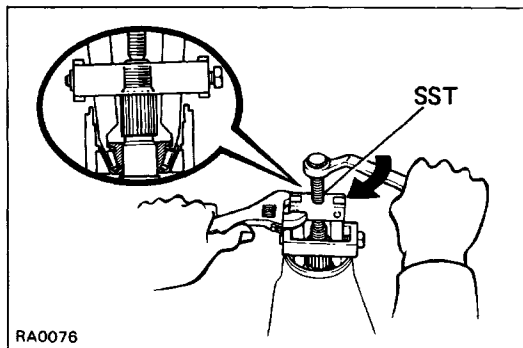

#### 5. REMOVE REAR BEARING AND BEARING SPACER

- (a) Using SST, remove the rear bearing from the drive pinion.  
SST 09556-30010
- (b) Remove the bearing spacer.

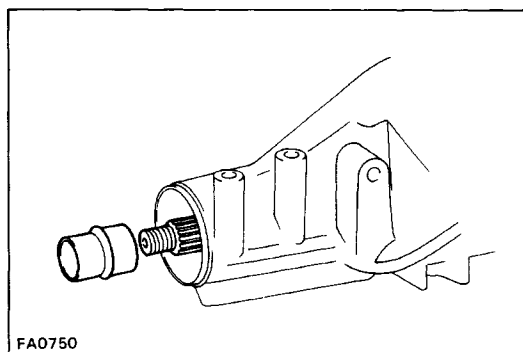

#### 6. INSTALL NEW BEARING SPACER AND REAR BEARING

- (a) Install a new bearing spacer on the drive pinion.
- (b) Install the rear bearing on the drive pinion.

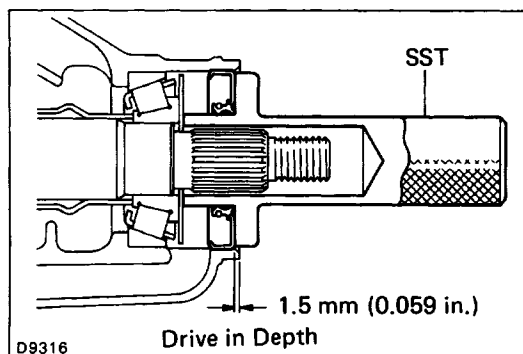

#### 7. INSTALL OIL SLINGER AND NEW OIL SEAL

- (a) Install the oil slinger.
- (b) Using SST, drive in a new oil seal.  
SST 09554-30011  
Oil seal drive in depth: 1.5 mm (0.059 in.)
- (c) Apply MP grease to the oil seal lip.

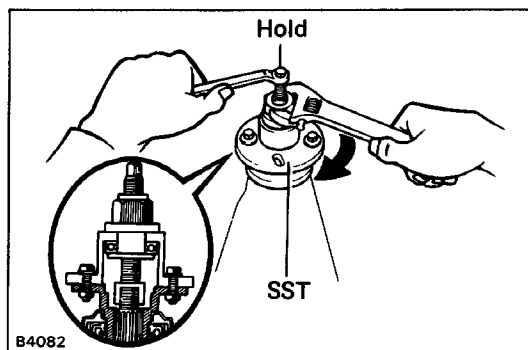

## 8. INSTALL COMPANION FLANGE

- (a) Using SST, install the companion flange on the drive pinion.

SST 09557-22022 (09557-22030)

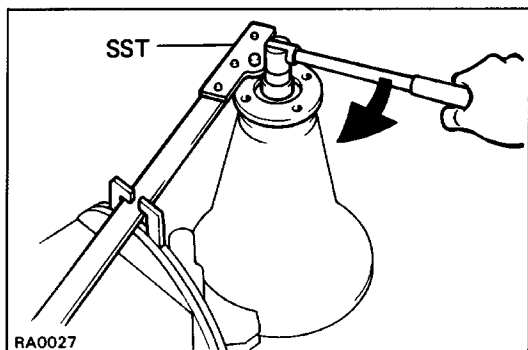

- (b) Coat the threads of the new nut with MP grease.

- (c) Using SST to hold the flange, torque the nut.

SST 09330-00021

**Torque: 120 N-m (1,225 kgf-cm, 89 ft-lbf)**

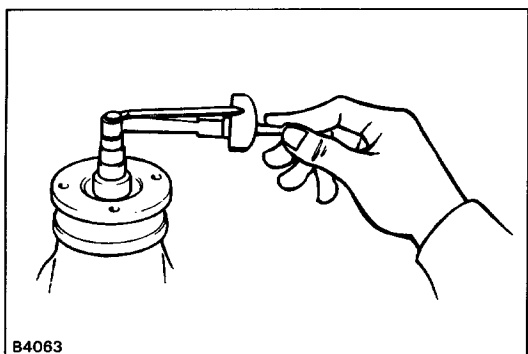

## 9. ADJUST DRIVE PINION BEARING PRELOAD

Using a torque meter, measure the preload of the back-lash between the drive pinion and ring gear.

**Preload (starting):**

**New bearing**

1.2 – 1.9 N-m

(12 – 19 kgf-cm, 10.4 – 16.5 in.-lbf)

**Reused bearing**

0.6 – 1.0 N-m

(6 – 10 kgf-cm, 5.2 – 8.7 in.-lbf)

- (a) If the preload is greater than specification, replace the bearing spacer.

- (b) If the preload is less than specification, retighten the nut 13 N-m (130 kgf-cm, 9 ft-lbf) a little at a time until the specified preload is reached.

**Maximum torque: 223 N-m (2,275 kgf-cm, 165 ft-lbf)**

If the maximum torque is exceeded while retightening the nut, replace the bearing spacer and repeat the preload procedure. Do not back off the pinion nut to reduce the preload.

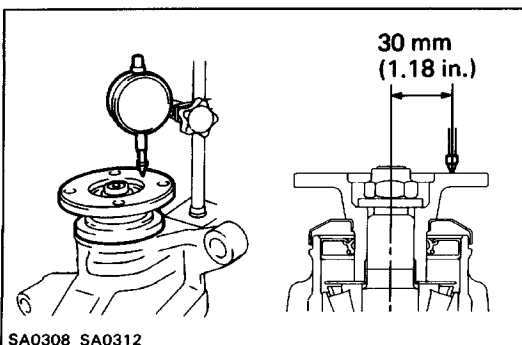

## 10. CHECK RUNOUT OF COMPANION FLANGE

Using a dial indicator, measure the vertical and lateral runout of the companion flange.

**Maximum vertical runout: 0.10 mm (0.0039 in.)**

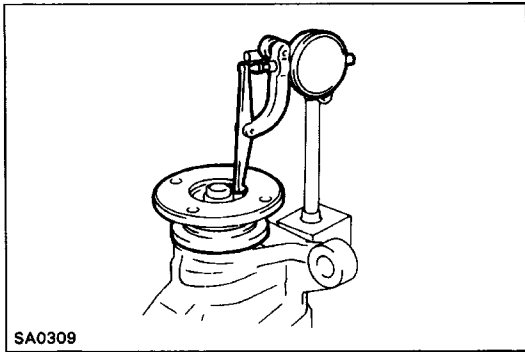

**Maximum lateral runout: 0.10 mm(0.0039 in.)**

If the runout is greater than maximum, inspect the bearings.

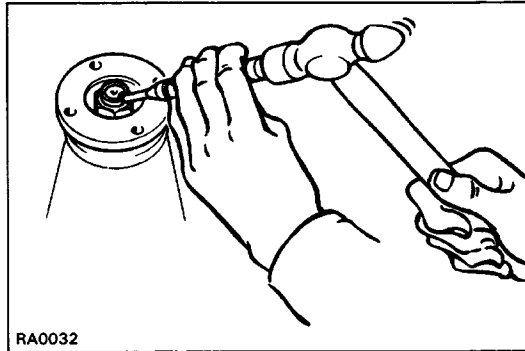

**11. STAKE DRIVE PINION NUT**

**12. INSTALL DRAIN PLUG AND FILL DIFFERENTIAL WITH GEAR OIL**

(w/ A.D.D.)

Oil type: Toyota "GEAR OIL SUPER" oil (Part No. 08885 – 02106) or hypoid gear oil API GL-5

Recommended oil viscosity: SAE 75W-90

Capacity: 1.86 liters (1.97 US qts, 1.64 Imp. qts)

(w/o A.D.D.)

Oil type: Hypoid gear oil API GL-5

Recommended oil viscosity:

Above – 18°C (0°F) SAE 90

Below – 18 °C (0 °F) SAE 80W or 80W-90

Capacity: 1.6 liters (1.7 US qts, 1.4 Imp. qts)

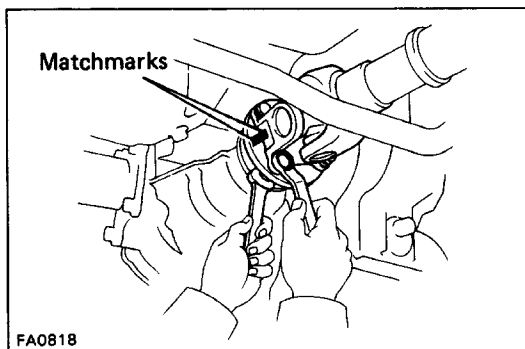

**13. CONNECT PROPELLER SHAFT TO COMPANION FLANGE**

(a) Align the matchmarks and connect the propeller shaft to the companion flange with four bolts and nuts.

(b) Torque the nuts.

**Torque: 74 N-m (750 kgf-cm, 54 ft-lbf)**

## Removal of Front Differential

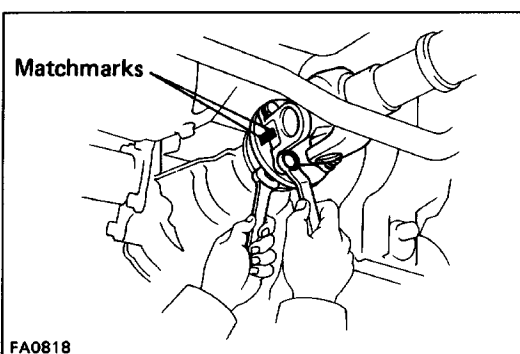
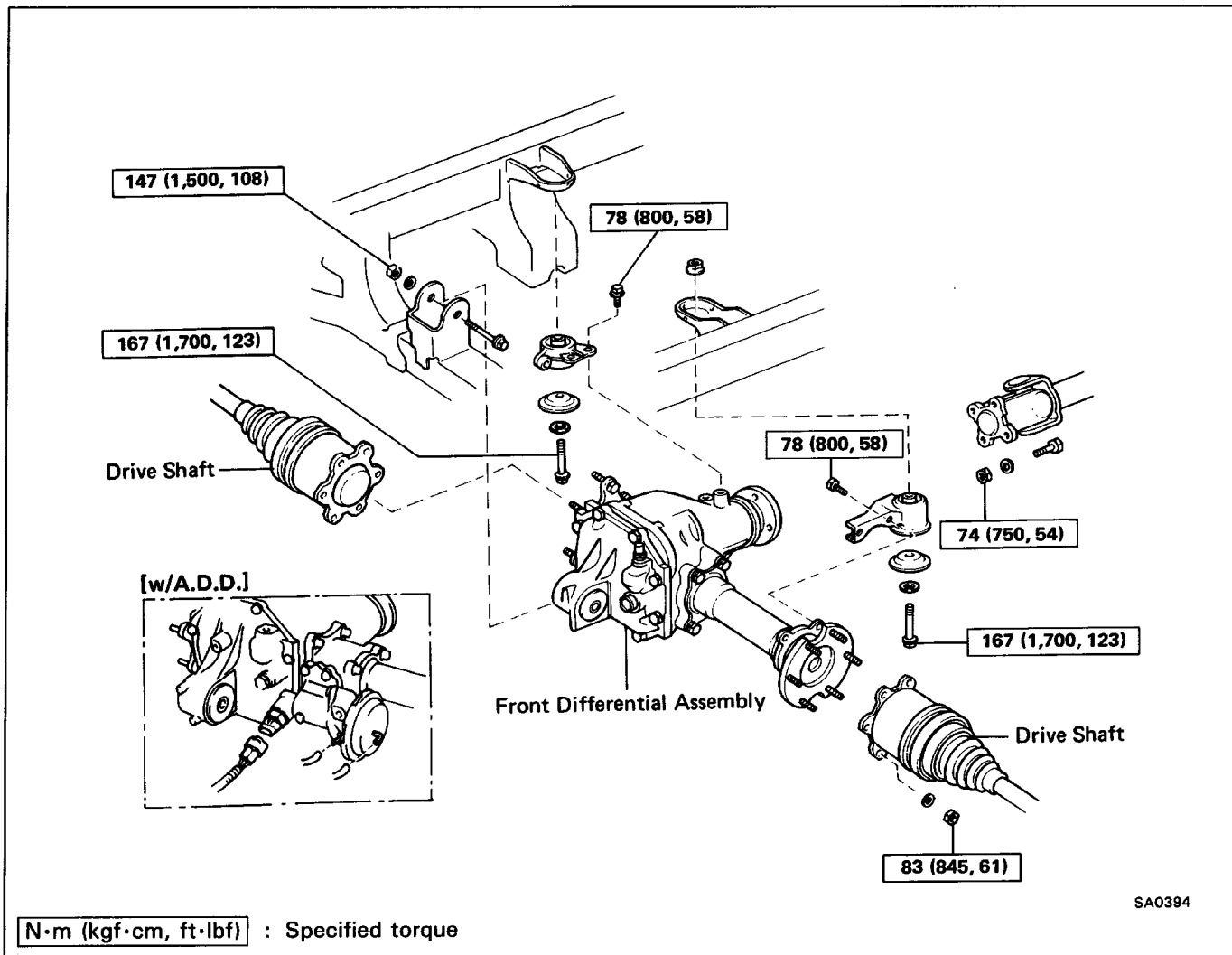

### 1. DRAIN DIFFERENTIAL OIL

### 2. DISCONNECT PROPELLER SHAFT

Before disconnecting the propeller shaft, place matchmarks.

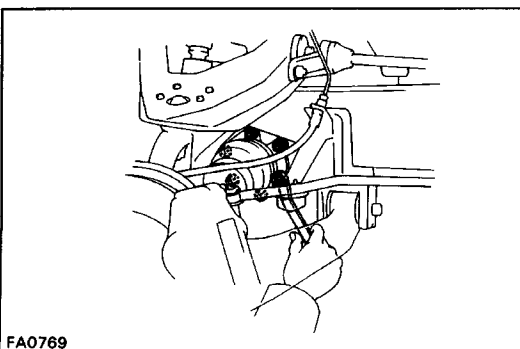

### 3. DISCONNECT DRIVE SHAFTS FROM SIDE GEAR SHAFT

Loosen the six nuts, while depressing the brake pedal, and disconnect the drive shafts from the side gear shaft.

### 4. (w/ A.D.D.)

**DISCONNECT VACUUM HOSES AND 4WD INDICATOR SWITCH CONNECTOR**

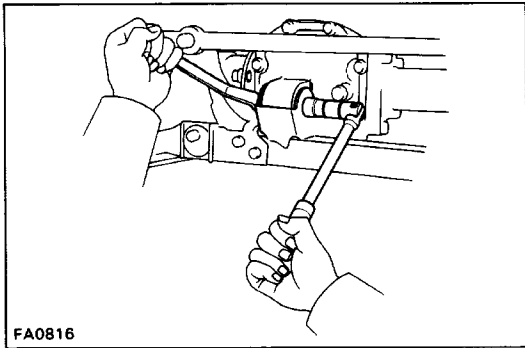

### 5. REMOVE FRONT DIFFERENTIAL FRONT MOUNTING BOLT AND NUT

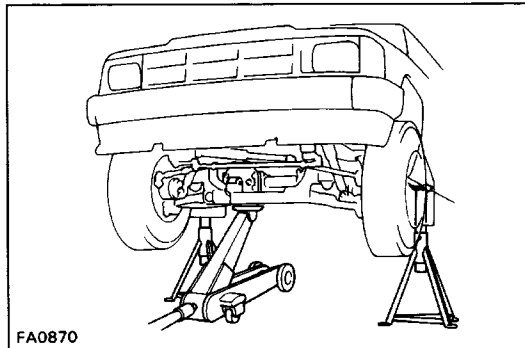

### 6. REMOVE FRONT DIFFERENTIAL

(a) Hold the front differential with a jack.

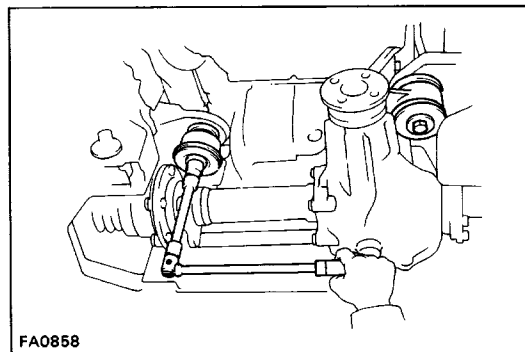

(b) Remove the left and right rear mounting bolts, and remove the front differential.

## Replacement of Side Oil Seal (without A.D.D.)

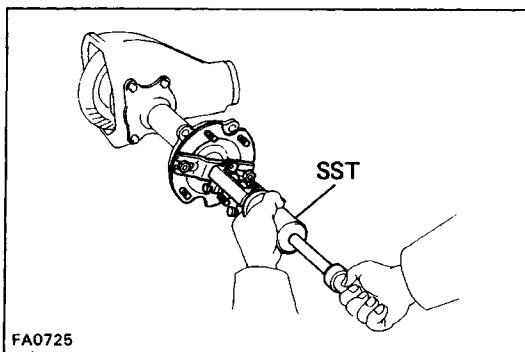
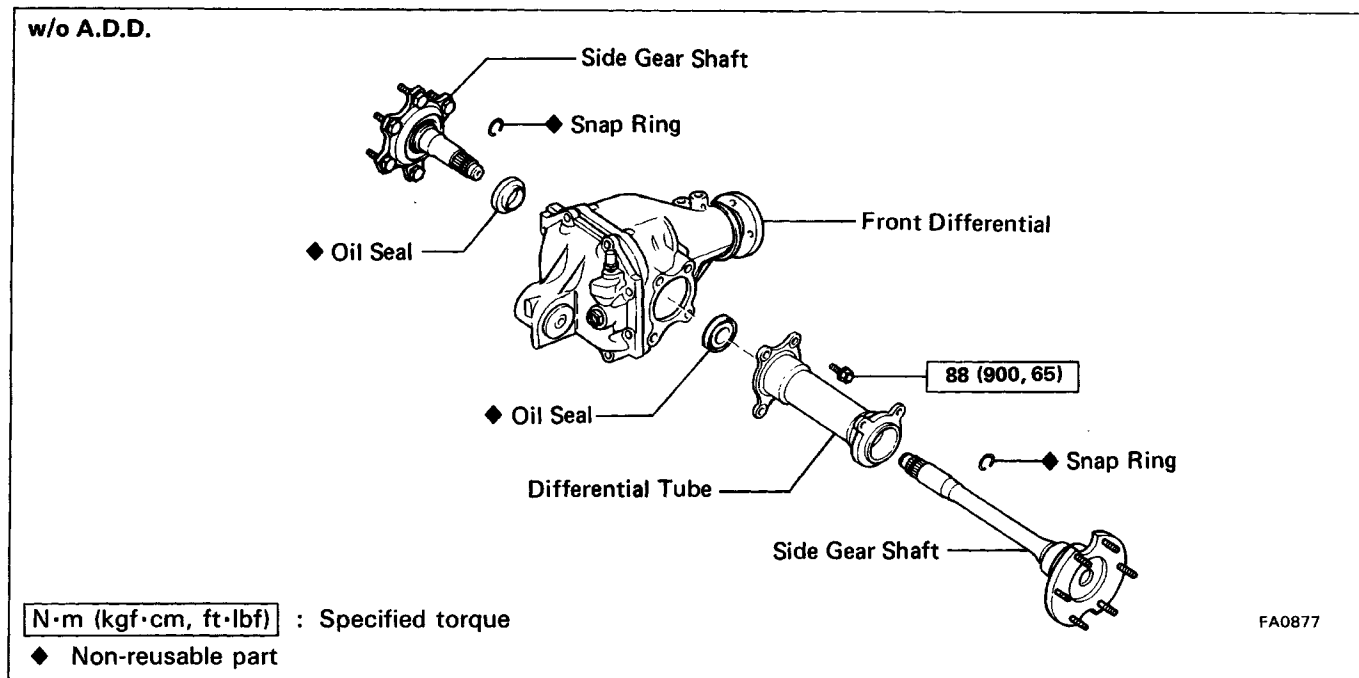

### 1. REMOVE SIDE GEAR SHAFT

Using SST, pull off the side gear shaft from the front differential.

SST 09910-00015

(09911-00011, 09912-00010, 09914-00011)

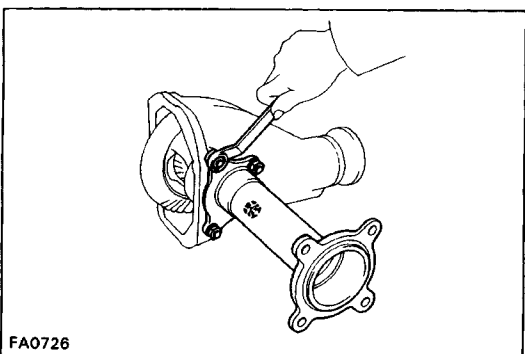

### 2. REMOVE FRONT DIFFERENTIAL TUBE

Remove the four bolts, and using a plastic-faced hammer, remove the differential tube.

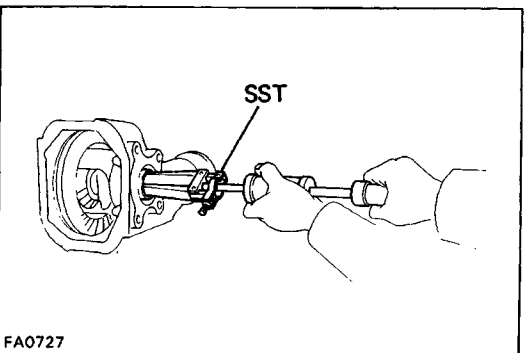

### 3. REMOVE SIDE GEAR SHAFT OIL SEAL

Using SST, remove the side gear shaft oil seal.

SST 09308-00010

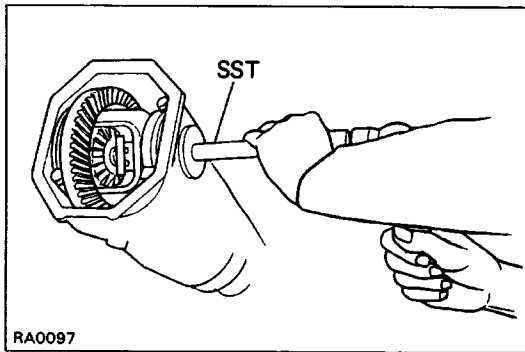

#### 4. INSTALL NEW SIDE GEAR SHAFT OIL SEAL

- (a) Using SST, drive in the oil seal until it is flush with the carrier end surface.

SST 09550-22011 (09550-00020, 09550-00031)

- (b) Coat the lip of oil seal with MP grease.

#### 5. INSTALL DIFFERENTIAL TUBE

Torque: 88 N-m (900 kgf-cm, 65 ft-lbf)

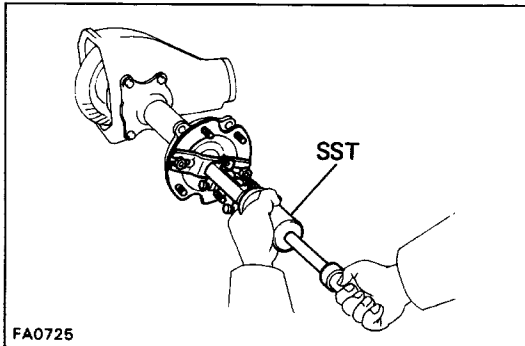

#### 6. INSTALL SIDE GEAR SHAFT

- (a) Install a new snap ring to the side gear shaft.

- (b) Using SST, install the side gear shaft until it contacts the pinion shaft.

SST 09910-00015

(09911-00011, 09912-00010, 09914-00011)

#### 7. CHECK INSTALLATION OF SIDE GEAR SHAFT

- (a) Check that there is 2 – 3 mm (0.08 – 0.12 in.) of play in axial direction.

- (b) Check that the side gear shaft will not come out by trying to pull it completely out by hand.



## Replacement of Side Oil Seal (with A.D.D.)

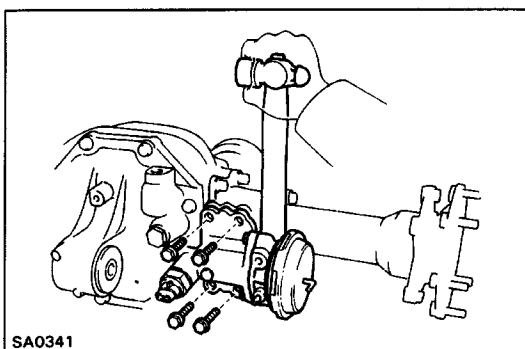
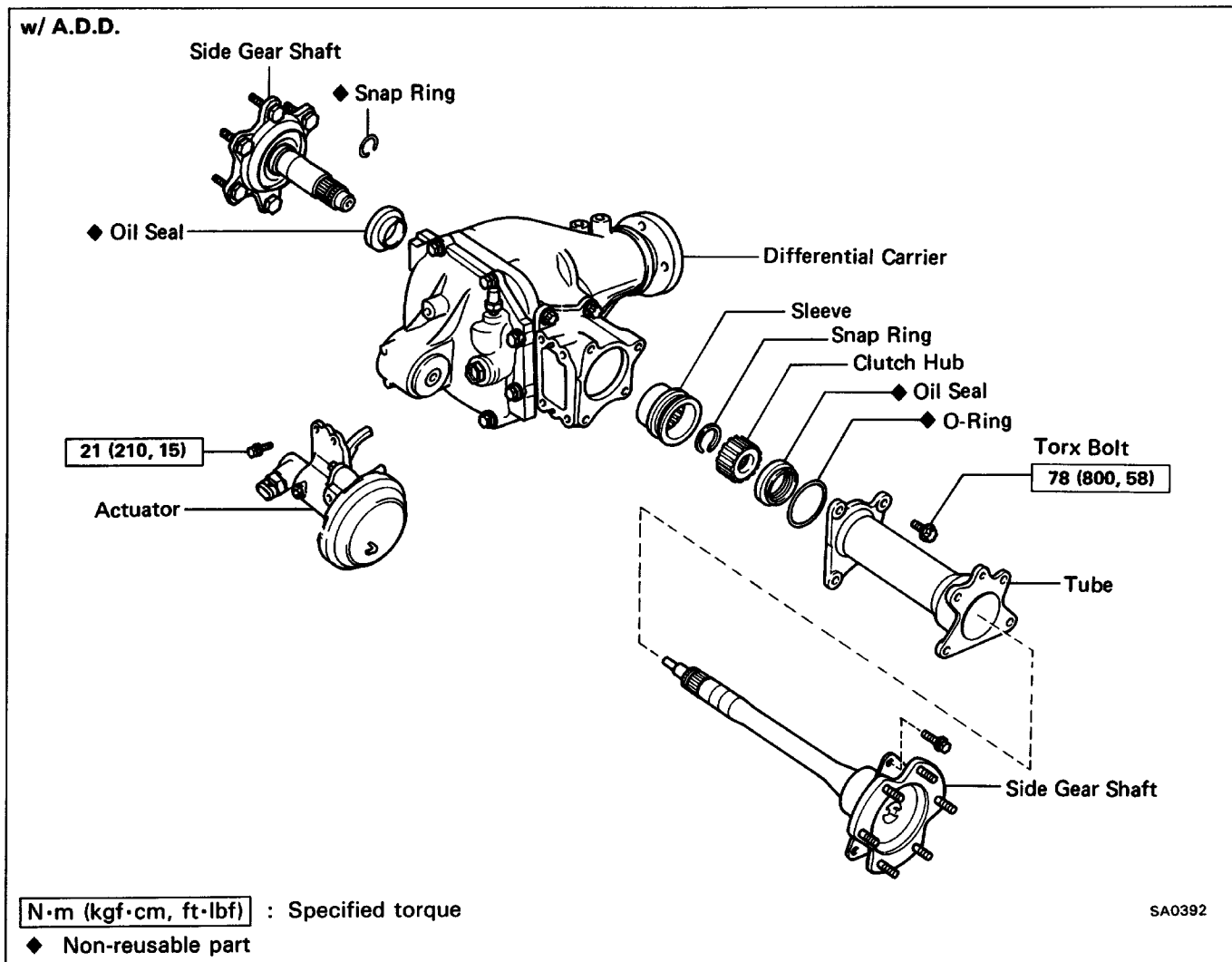

### REPLACEMENT OF LH SIDE OIL SEAL

#### 1. REMOVE ACTUATOR

- Remove the four bolts.
- Using a hammer, remove the actuator.

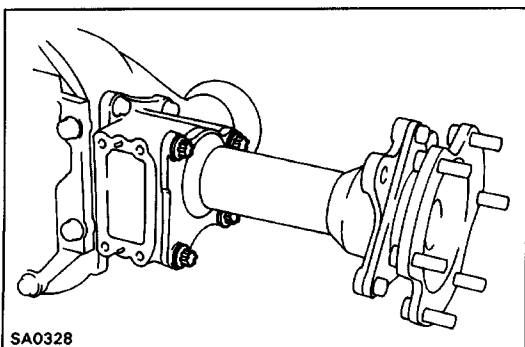

#### 2. REMOVE LH SIDE GEAR SHAFT WITH TUBE

- Remove the four torx bolts.  
Torx wrench: E 14 (part No. 09044-00010 or locally manufactured tool)

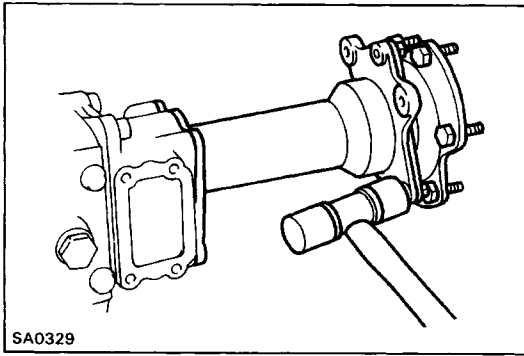

- (b) Using a plastic-faced hammer, tap on the tube to remove it.

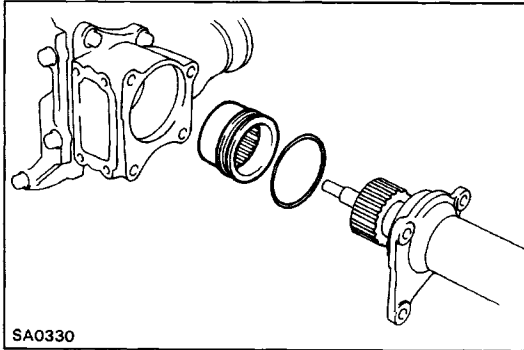

- (c) Remove the sleeve.  
 (d) Remove the O-ring from the tube.

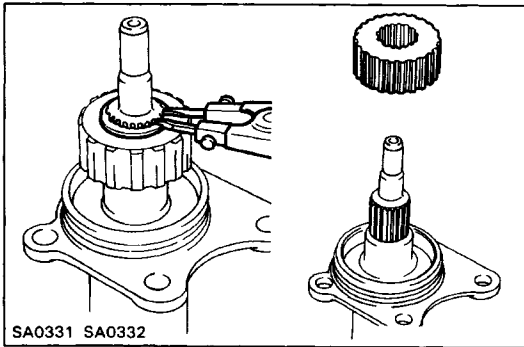

### 3. REMOVE CLUTCH HUB

- (a) Using a snap ring expander, remove the snap ring.  
 (b) Remove the clutch hub from the side gear shaft.

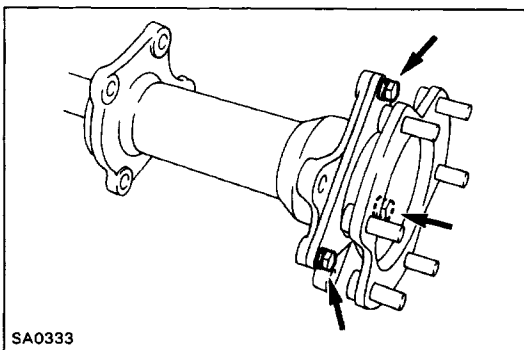

### 4. REMOVE SIDE GEAR SHAFT FROM TUBE

- (a) Remove the three bearing retainer bolts.  
 (b) Remove the side gear shaft from the tube.

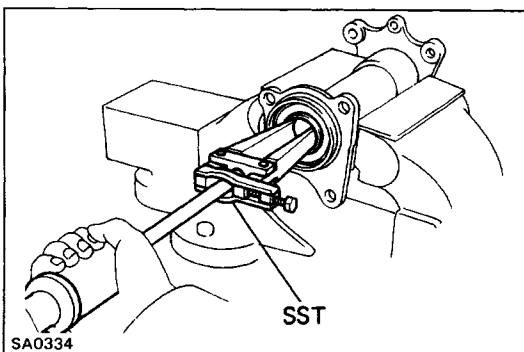

### 5. REPLACE SIDE OIL SEAL

- (a) Using SST, remove the side oil seal.  
 SST 09308-00010

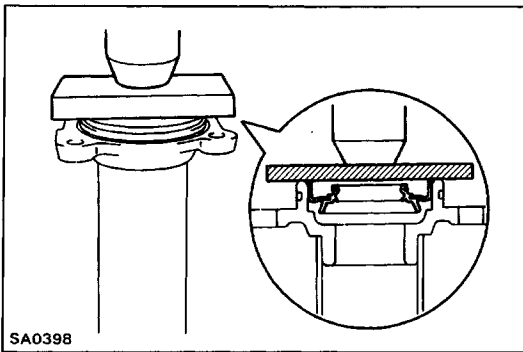

- (b) With the oil seal lip facing upward, use press and plate to press in a new side oil seal until its end is flush with the surface of the tube.

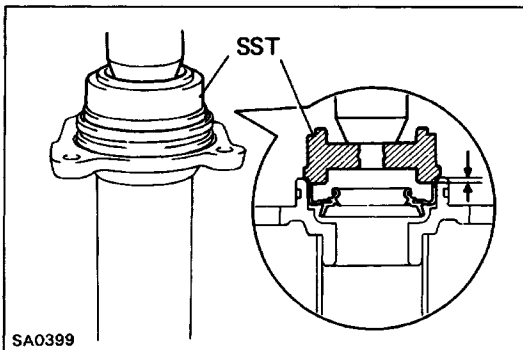

- (c) Using SST, press in the oil seal.  
SST 09554-14010  
Press in depth: 2.5 mm (0.098 in.)  
(d) Coat the lip of oil seal with IMP grease.

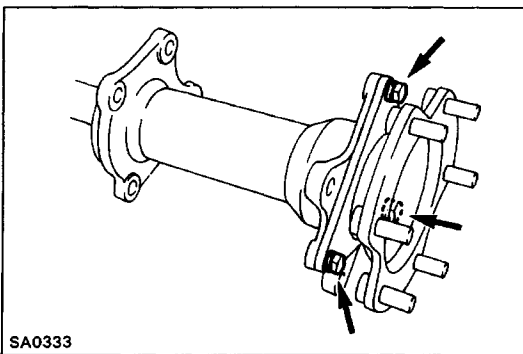

## 6. INSTALL SIDE GEAR SHAFT

- (a) Install the side gear shaft to the tube.  
(b) Tighten the three bearing retainer bolts.

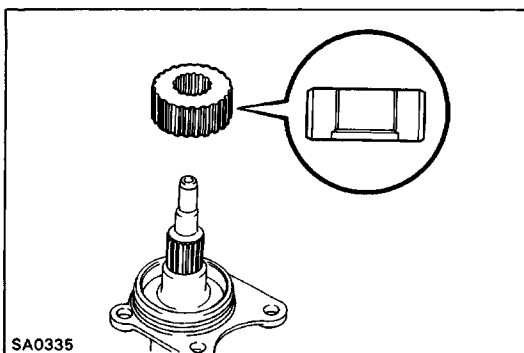

## 7. INSTALL CLUTCH HUB

- (a) Install the clutch hub to the shaft.

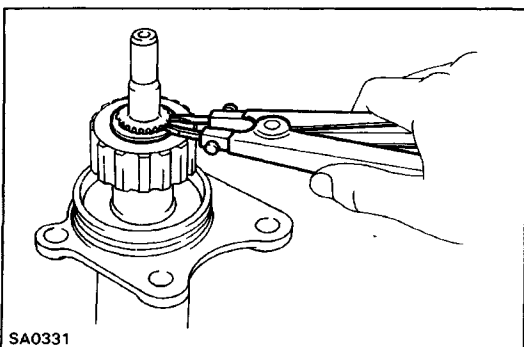

- (b) Using a snap ring expander, install the snap ring.

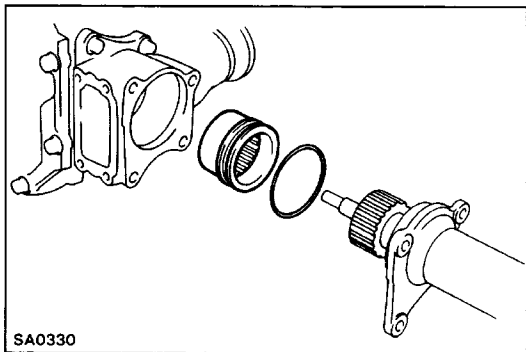

## 8. INSTALL SIDE GEAR SHAFT WITH TUBE TO DIFFERENTIAL CARRIER

- (a) Install a new 4-ring to the tube.
- (b) Install the sleeve onto the clutch hub.

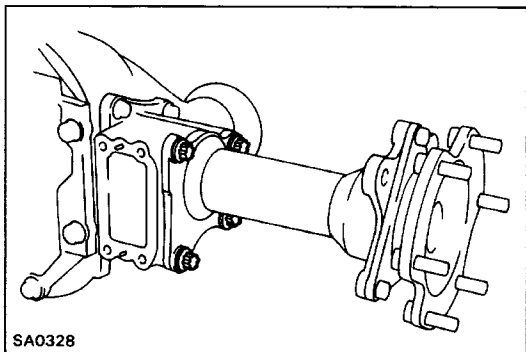

- (c) Install the side gear shaft with tube.
- (d) Tighten the four torx bolts.

**Torque: 78 N-m (800 kgf-cm, 58 ft-lbf)**

Torx wrench: E14 (Part No. 09044-00010 or locally manufactured tool)

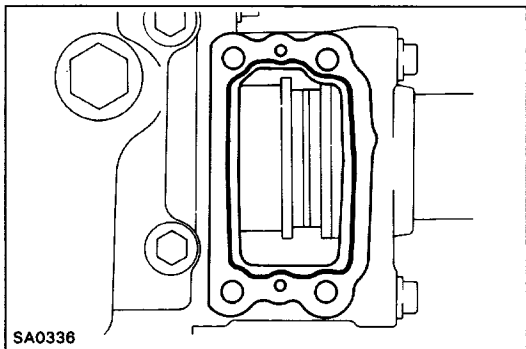

## 9. INSTALL ACTUATOR

- (a) Remove any packing material and be careful not to get oil on the contacting surfaces of the actuator and clutch case.
- (b) Apply seal packing to the clutch case as shown.

**Seal packing: Part No. 08826-00090, THREE BOND 1281 or equivalent**

HINT: Install the actuator within ten minutes after applying seal packing.

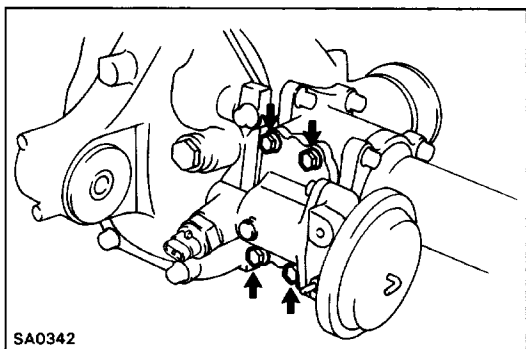

- (c) Tighten the four bolts.

**Torque: 21 N-m (210 kgf-cm, 15 ft-lbf)**

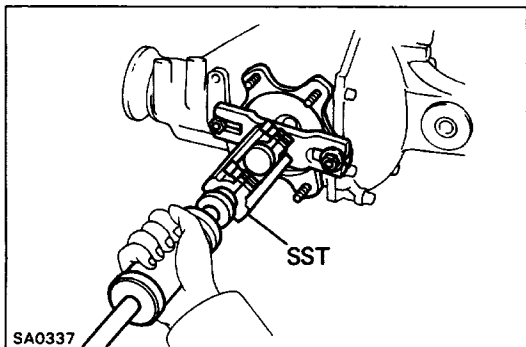

## REPLACEMENT OF RH SIDE OIL SEAL

### 1. REMOVE RH SIDE GEAR SHAFT

Using SST, pull off the RH side gear shaft from differential carrier.

SST 09910-00015

(09911-00011, 09912-00010, 09914-00011)

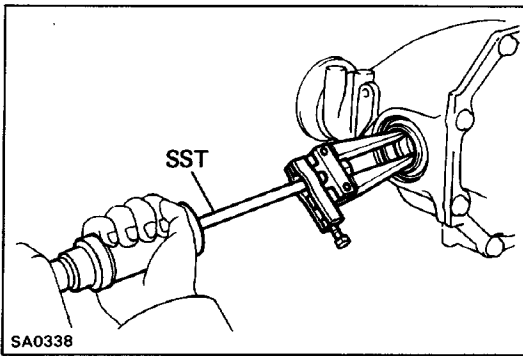

## 2. REPLACE SIDE OIL SEAL

- (a) Using SST, remove the oil seal.  
SST 09308-00010

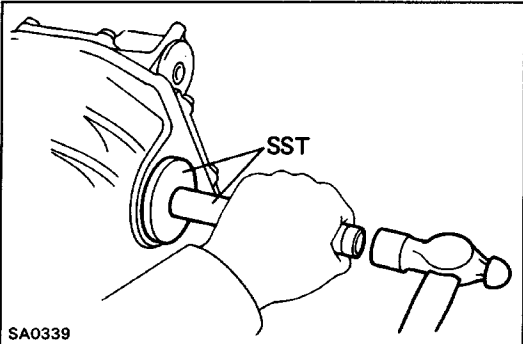

- (b) Using SST, install the new oil seal.  
SST 09550-22011 (09550-00020, 09550-0003)  
(c) Coat the lip of oil seal with MP grease.

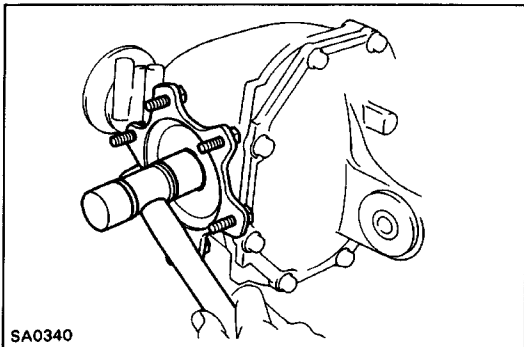

## 3. INSTALL RH SIDE GEAR SHAFT

- (a) Install a new snap ring to the side gear shaft.  
(b) Using a plastic-faced hammer, tap on the side gear shaft to install it.

## 4. CHECK INSTALLATION OF SIDE GEAR SHAFT

- (a) Check that there is 2 – 3 mm (0.08 – 0.12 in.) of play in axial direction.  
(b) Check that the side gear shaft will not come out by trying to pull it completely out by hand.

# Disassembly and Assembly of Differential (with out A.D.D.)

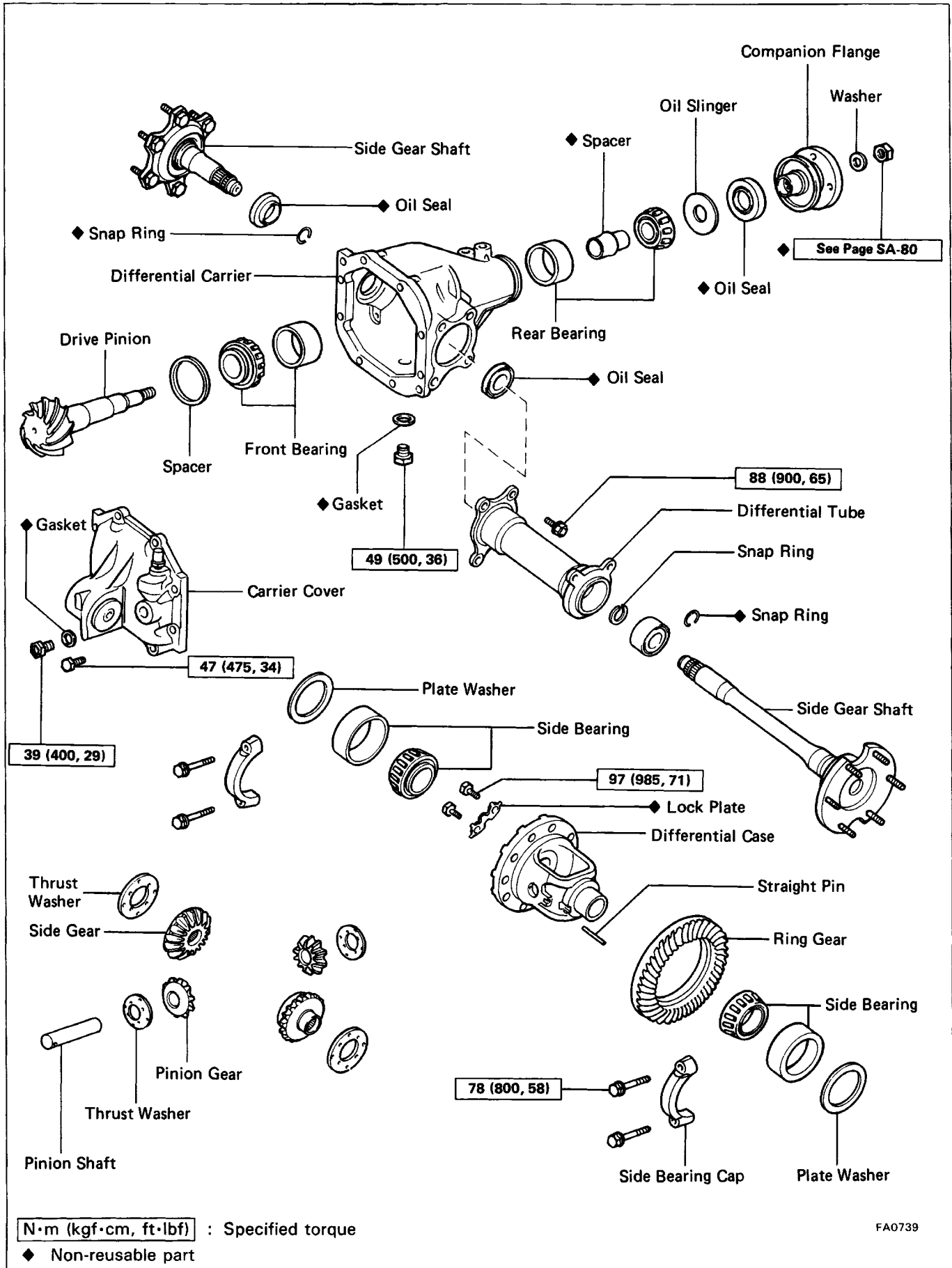

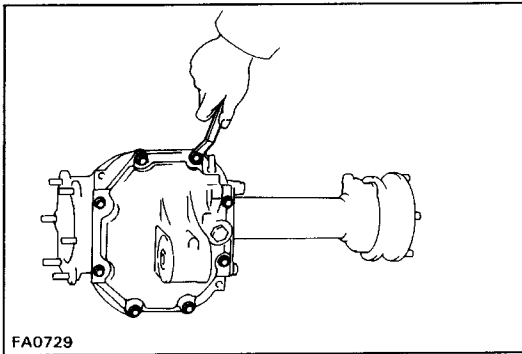

## DISASSEMBLY OF DIFFERENTIAL

### 1. REMOVE DIFFERENTIAL COVER

Remove the eight bolts and tap off the cover with a plastic-faced hammer.

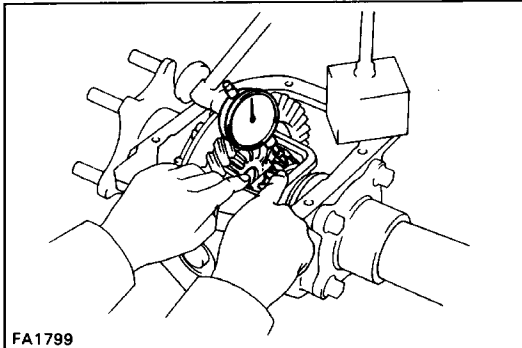

### 2. CHECK SIDE GEAR BACKLASH

Measure the side gear backlash while holding one pinion gear toward the case.

**Standard backlash: 0.05 – 0.20 mm**

**(0.0020 – 0.0079 in.)**

If the backlash is out of specification, install the correct thrust washers. (See page [SA-71](#) )

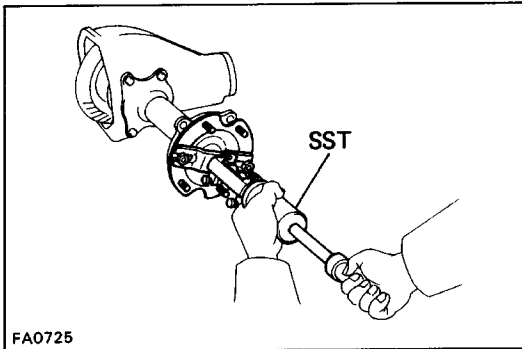

### 3. REMOVE SIDE GEAR SHAFTS

Using SST, remove the side gear shafts from the differential.

SST 09910-00015 .

(09911-00011, 09912-00010, 09914-00011)

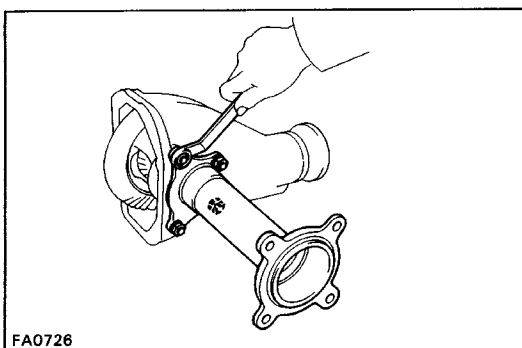

### 4. REMOVE DIFFERENTIAL TUBE

Remove the four bolts and tap off the cover with a plastic-faced hammer.

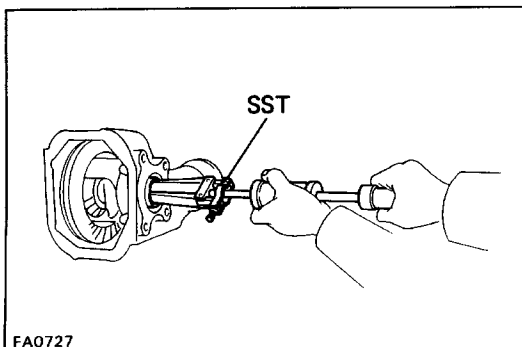

### 5. REMOVE SIDE GEAR SHAFT OIL SEALS

Using SST, remove the oil seals.

SST 09308-00010

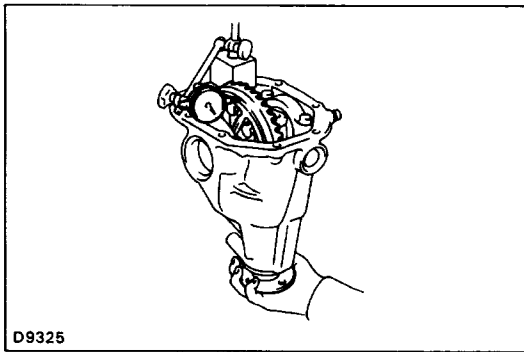

## 6. CHECK RING GEAR RUNOUT

Using a dial indicator, measure the ring gear runout.

**Maximum runout: 0.07 mm (0.0028 in.)**

If the runout is greater than maximum, replace the ring gear and drive pinion as a set.

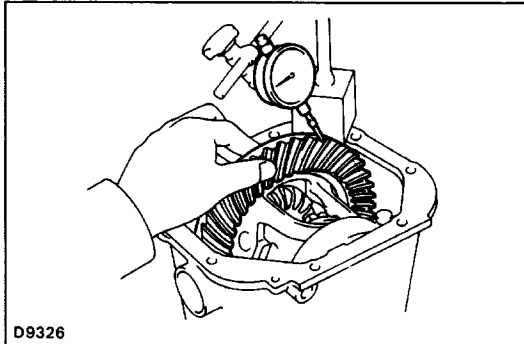

## 7. CHECK RING GEAR BACKLASH

(a) Fix the dial indicator on the tooth surface at a 90° angle.

(b) Holding the drive pinion flange, measure the ring gear backlash.

**Ring gear backlash: 0.13 – 0.18 mm**

**(0.0051 – 0.0071 in.)**

If the backlash is not within specification, adjust the ring gear backlash.

**HINT:** Measure from three or more places on the circumference of the ring gear.

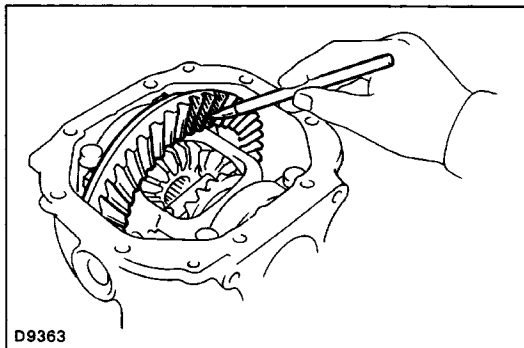

## 8. INSPECT TOOTH CONTACT BETWEEN RING GEAR AND DRIVE PINION (SEE STEP 7 ON PAGE SA-78)

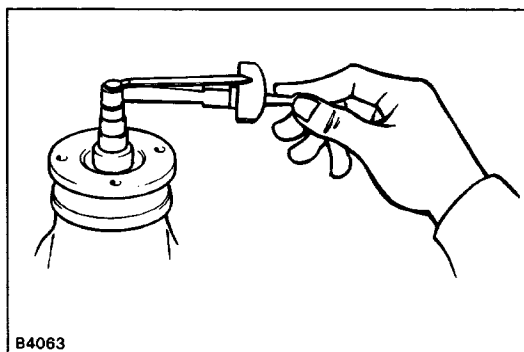

## 9. MEASURE DRIVE PINION PRELOAD

Using a torque gauge, measure the preload of the backlash between the drive pinion and ring gear.

**Preload (starting):**

**0.6 – 1.0 N-m (6 – 10 kgf-cm, 5.2 – 8.7 in.-lbf)**

## 10. CHECK TOTAL PRELOAD

Using a torque gauge, measure the total preload.

**Total preload (starting):**

**Add drive pinion preload**

**0.4 – 0.6 N-m**

**(4 – 6 kgf-cm, 3.5 – 5.2 in.-lbf)**

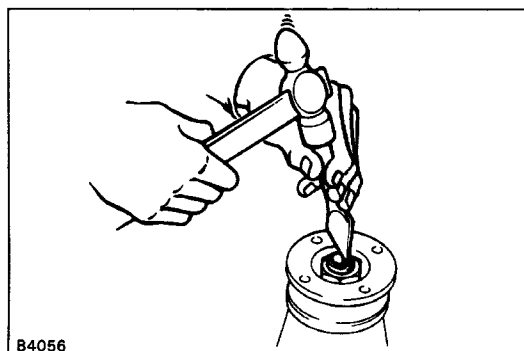

## 11. REMOVE COMPANION FLANGE

(a) Using a hammer and chisel, loosen the staked part of the nut.



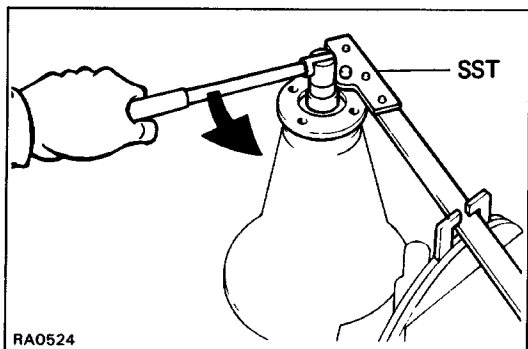

- (b) Using SST to hold the flange, remove the nut.  
SST 09330-00021

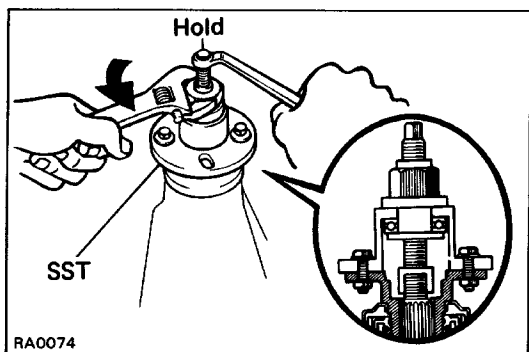

- (c) Using SST, remove the companion flange.  
SST 09557-22022 (09557-22030)

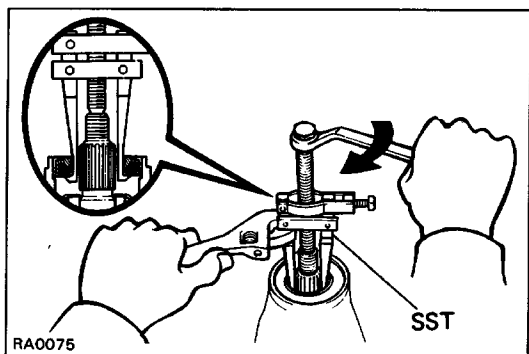

## 12. REMOVE OIL SEAL AND OIL SLINGER

- (a) Using SST, remove the oil seal from the housing.  
SST 09308-10010  
(b) Remove the oil slinger.

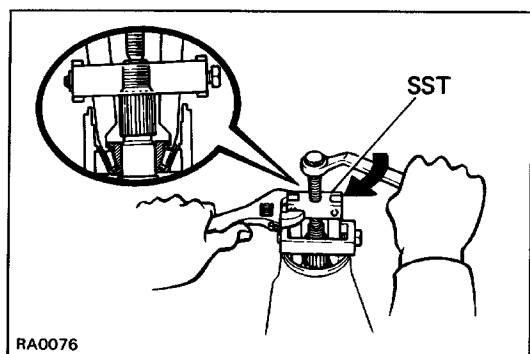

## 13. REMOVE REAR BEARING AND BEARING SPACER

- (a) Using SST, remove the rear bearing from drive pinion.  
SST 09556-30010  
(b) Remove the bearing spacer.  
If the rear bearing is damaged or worn, replace the bearing.

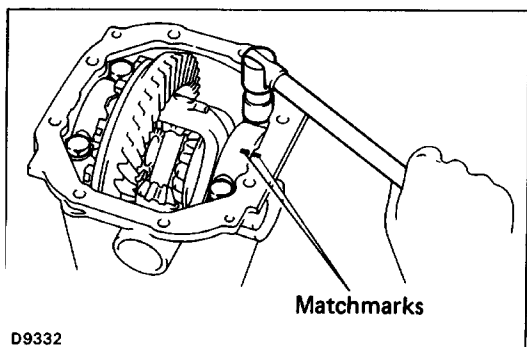

## 14. REMOVE DIFFERENTIAL CASE AND RING GEAR

- (a) Place matchmarks on the bearing cap and differential carrier.  
(b) Remove the two bearing caps.

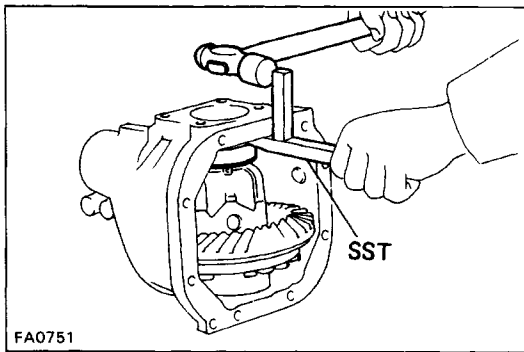

- (c) Using SST and a hammer, remove the two side bearing preload adjusting plate washers.  
SST 09504-22011

HINT: Measure the adjusting plate washer and note the thickness.

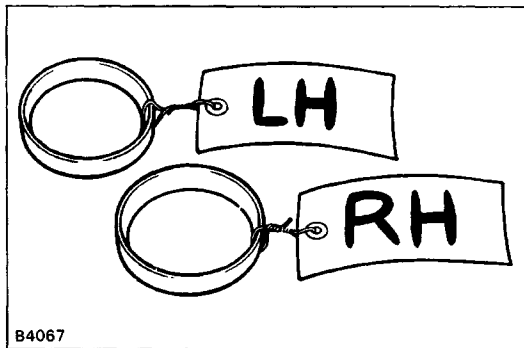

- (d) Remove the differential case with bearing outer race from the carrier.  
HINT: Tag the bearing outer races to show the location for reassembly.

## 15. REMOVE DRIVE PINION FROM DIFFERENTIAL CARRIER

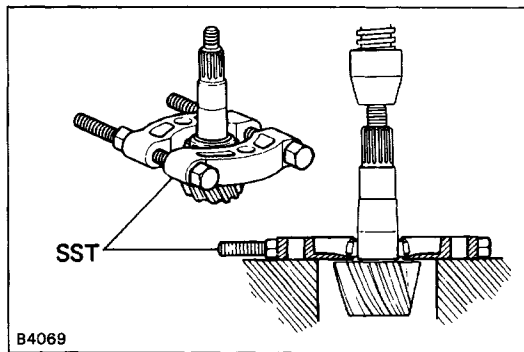

## INSPECTION AND REPLACEMENT OF DIFFERENTIAL

### 1. REPLACE DRIVE PINION FRONT BEARING

4ay Using SST, press out the front bearing from the drive pinion.

SST 09950-00020

HINT: If the drive pinion or ring gear are damaged, replace them as a set.

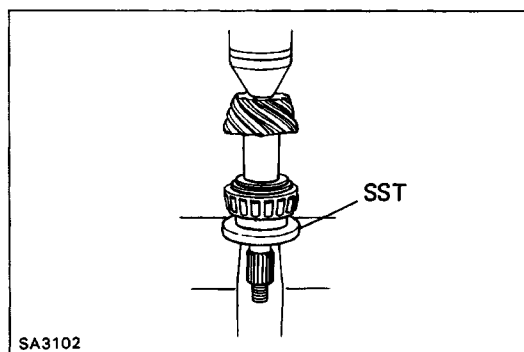

- (b) Install the washer on the drive pinion.  
(c) Using SST, press in the front bearing onto the drive pinion.  
SST 09506-30012

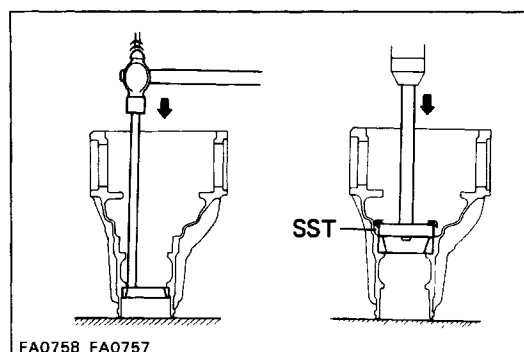

### 2. REPLACE DRIVE PINION FRONT AND REAR BEARING OUTER RACES

(a) Using a brass bar and hammer, drive out the outer race.

(b) Using SST, drive in a new outer race.

SST 09608-35014

Front outer race (09608-06020, 09608-06120)

Rear outer race (09608-06020, 09608-06110)

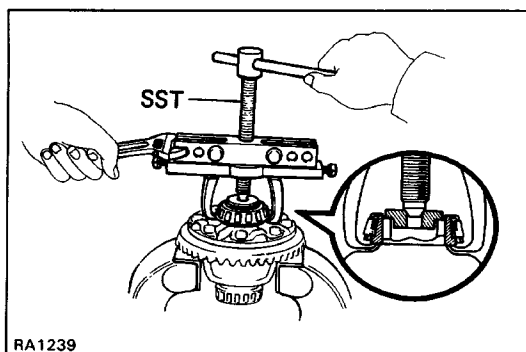

### 3. REMOVE SIDE BEARING FROM DIFFERENTIAL CASE

Using SST, remove the side bearing from the differential case.

SST 09950-20017

HINT: Fix the claws of SST to the notches in the differential case.

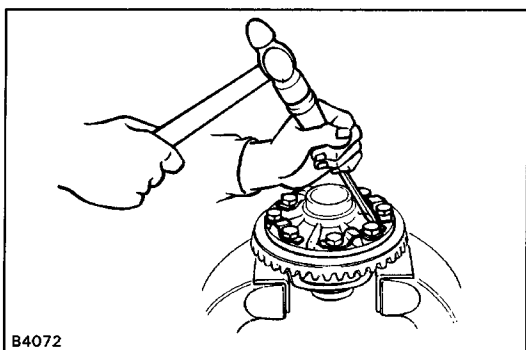

### 4. REMOVE RING GEAR

(a) Remove the ring gear set bolts and lock plates.

(b) Place matchmarks on the ring gear and differential case.

(c) Using a plastic-faced hammer, tap on the ring gear to separate it from the differential case.

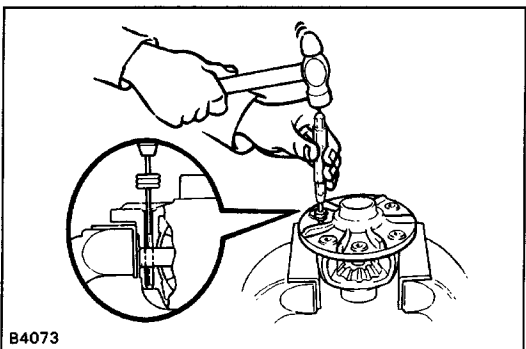

### 5. DISASSEMBLE DIFFERENTIAL CASE

Using a hammer and punch, drive out the straight pin.

Remove the pinion shaft, two pinion gears, two side gears and four thrust washers.

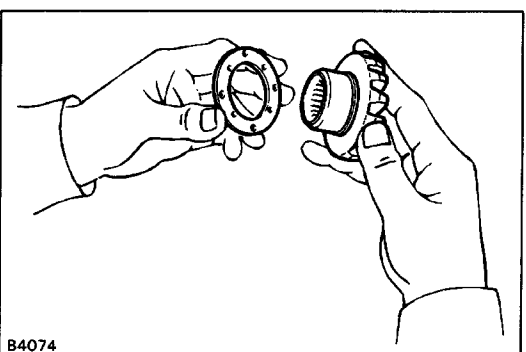

### 6. ASSEMBLE DIFFERENTIAL CASE

(a) Install the correct thrust washers and side gears.

From the table below select thrust washers that will ensure the backlash is within specification. Try to select washers of the same thickness for both sides.

**Standard backlash: 0.05 – 0.20 mm**

**(0.0020 – 0.0079 in.)**

Thrust washer thickness

Thickness mm (in.)	
0.96 – 1.04	(0.0378 – 0.0409)
1.06 – 1.14	(0.0417 – 0.0449)
1.16 – 1.24	(0.0457 – 0.0488)
1.26 – 1.34	(0.0496 – 0.0528)

Install the thrust washers and side gears in the differential case.

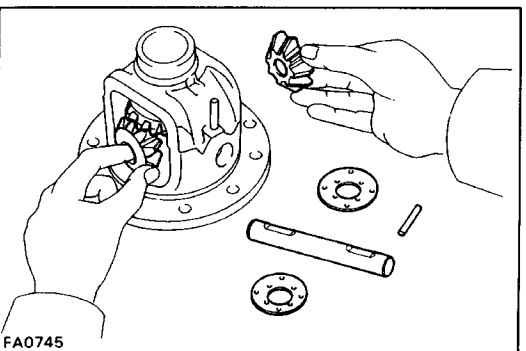

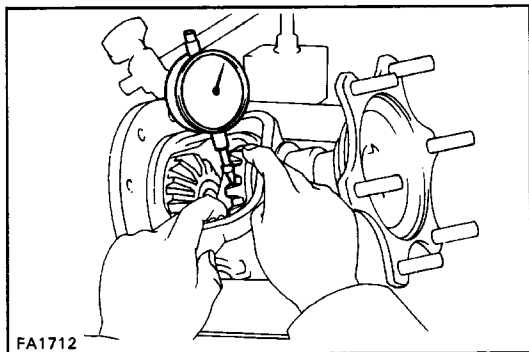

- (b) Check the side gear backlash.
- Temporarily install the side gear shaft.
  - Measure the side gear backlash while holding one pinion gear toward the case.

**Side gear backlash: 0.05 – 0.20 mm**

**(0.0020 – 0.0079 in.)**

If the backlash is not within specification, replace the thrust washers.

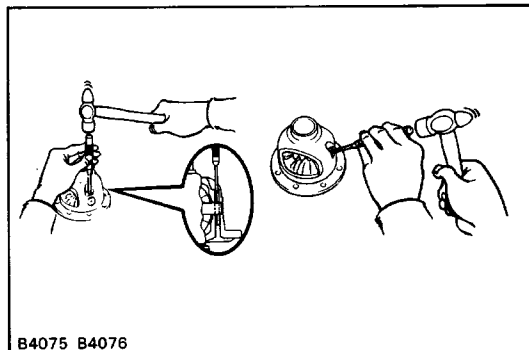

- (c) Install straight pin.

- Using a hammer and punch, drive the straight pin through the case and hole in the pinion shaft.
- Stake the pin and differential case.

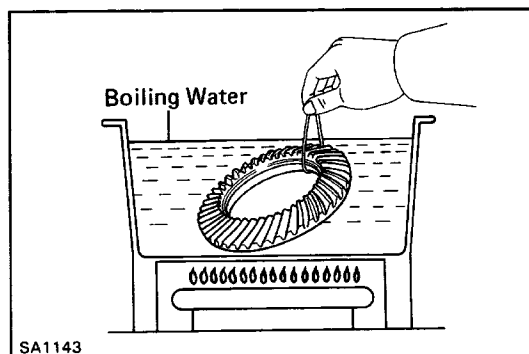

## 7. INSTALL RING GEAR ON DIFFERENTIAL CASE

- (a) Clean the contact surfaces of the differential case and ring gear.

- (b) Heat the ring gear in boiling water.

- (c) After the moisture on the ring gear has completely evaporated, quickly install the ring gear to the differential case.

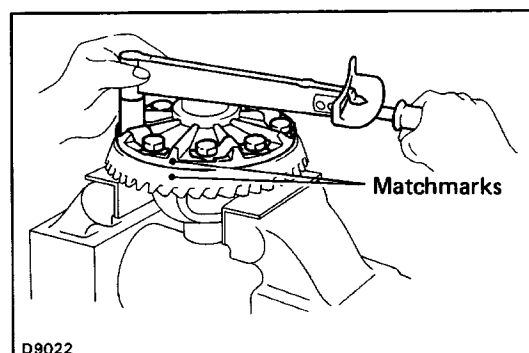

- (d) Align the matchmarks on the ring gear and differential case.

- (e) Coat the ring gear set bolts with gear oil.

- (f) Temporarily install the lock plates and set bolts.

- (g) After the ring gear cools down enough, tighten the set bolts uniformly and a little at a time.

**Torque: 97 N-m (985 kgf-cm, 71 ft-lbf)**

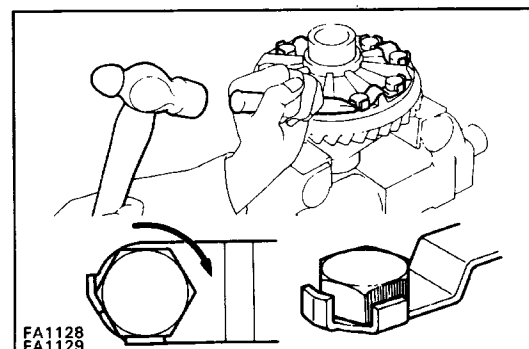

- (h) Using a hammer and drift punch, stake the lock plates.

**HINT:** Stake one claw flush with the flat surface of the nut. For the claw contacting the protruding portion of the nut, stake only the half on the tightening side.

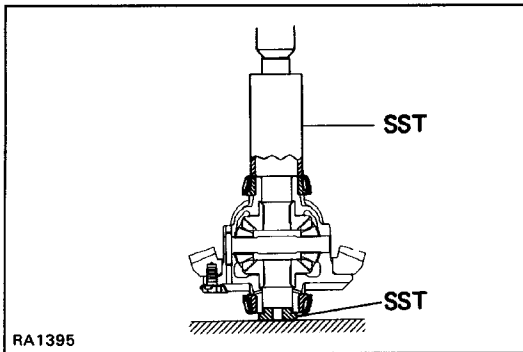

## 8. INSTALL SIDE BEARINGS

Using a press and SST, drive in the side bearings into the differential case.

SST 09226-10010, 09950-20017

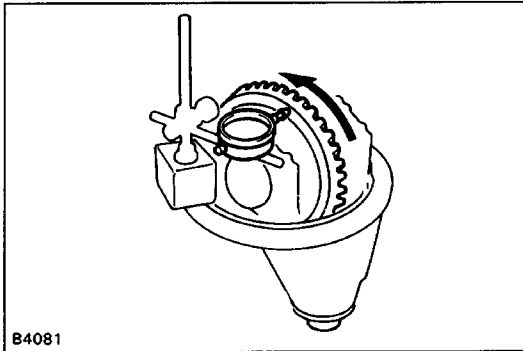

## 9. CHECK RING GEAR RUNOUT

(a) Install the differential case onto the carrier and install the plate washers to where there is no play in the bearing. (See page SA-75)

(b) Install bearing caps. (See page SA-77)

(e) Using a dial indicator, measure the runout of ring gear.

**Maximum runout: 0.07 mm (0.0028 in.)**

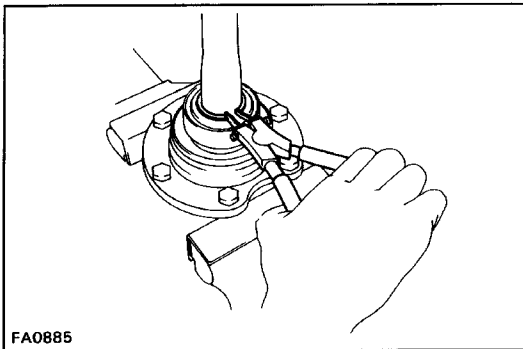

## 10. REPLACE LH SIDE GEAR SHAFT BEARING

(a) Using a snap ring expander, remove the snap ring.

(b) Using SST, remove the bearing from the LH side gear shaft.

SST 09950-20017

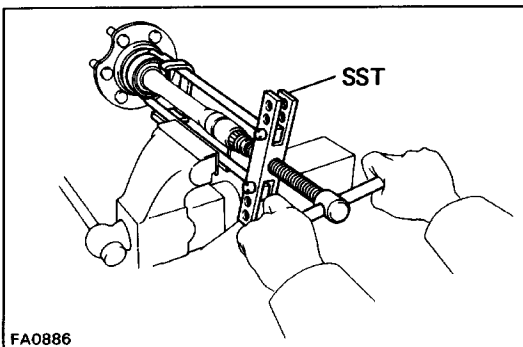

(c) Install a new bearing to the LH side gear shaft.

(d) Using a snap ring expander, install the snap ring.

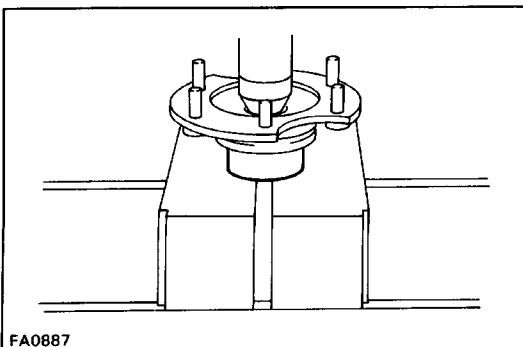

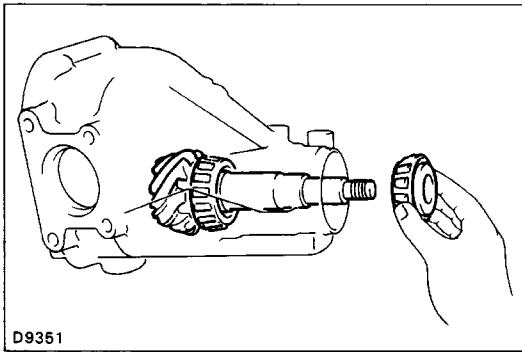

## ASSEMBLY OF DIFFERENTIAL

(See page SA-67)

### 1. TEMPORARILY ADJUST DRIVE PINION PRELOAD

(a) Install the following parts.

- Drive pinion
- Front bearing

HINT: Assemble the spacer and oil seal after adjusting the gear contact pattern.

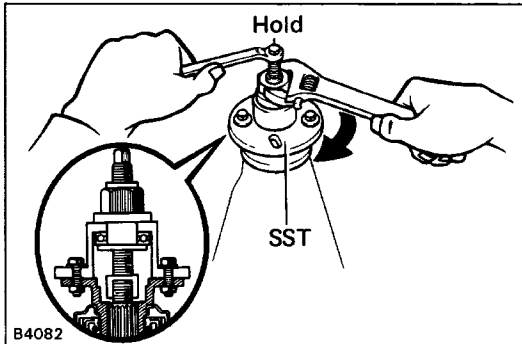

(b) Install the companion flange with SST.

Coat the threads of the nut with MP grease.

SST 09557-22022 (09557-22030)

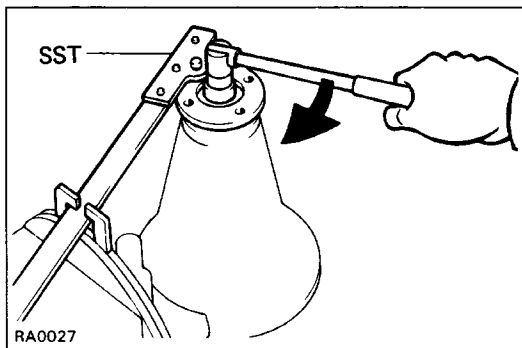

(e) Adjust the drive pinion preload by tightening the companion flange nut.

Using SST to hold the flange, tighten the nut.

SST 09330-00021

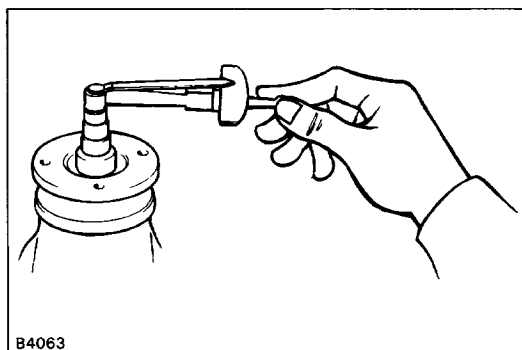

(d) Using a torque meter, measure the preload.

**Preload (starting):**

**New bearing**

1.2 – 1.9 N-m

(12 – 19 kgf-cm, 10.4 – 16.5 in.-lbf)

**Reused bearing**

0.6 – 1.0 N-m

(6 – 10 kgf-cm, 5.2 – 8.7 in.-lbf)

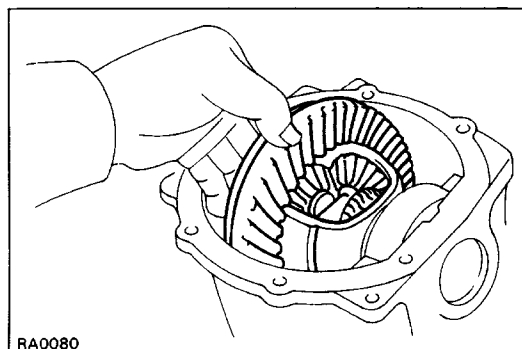

### 2. INSTALL DIFFERENTIAL CASE IN CARRIER

(a) Place the bearing outer races on their respective bearings. Make sure the left and right outer races are not interchanged.

(b) Install the differential case in the carrier.

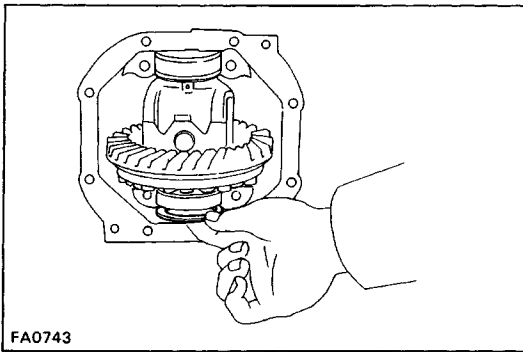

### 3. ADJUST RING GEAR BACKLASH

- (a) Install only the plate washer on the ring gear back side.

HINT: Insure that the ring gear has backlash.

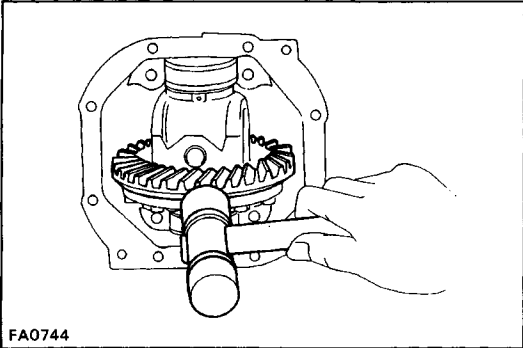

- (b) Snug down the washer and bearing by tapping on the ring gear with a plastic-faced hammer.

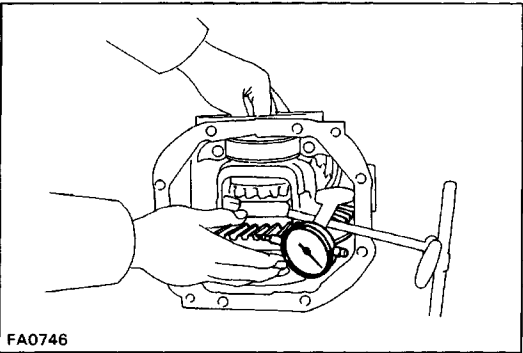

- (c) Hold the side bearing boss on the teeth surface of the ring gear and measure the backlash.

**Backlash (reference): 0.13 mm (0.0051 in.)**

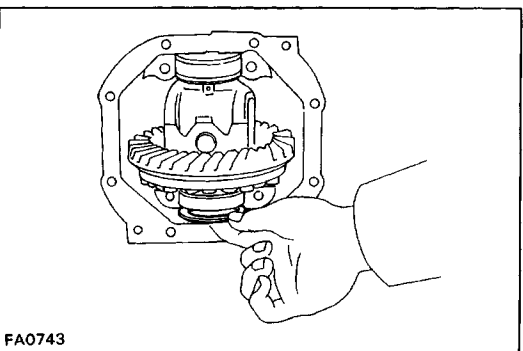

- (d) Select a ring gear back plate washer, using the backlash as reference. (See page [SA-77](#))

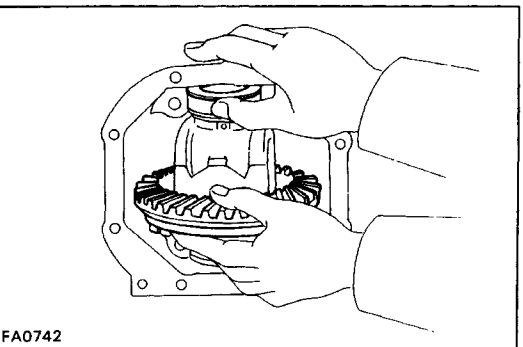

- (e) Select a ring gear teeth side washer with a thickness which eliminates any clearance between the outer race and case.

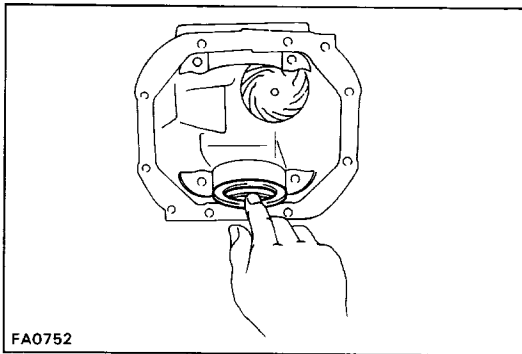

- (f) Remove the plate washers and differential case.
- (g) Install the plate washer into the lower part of the carrier.

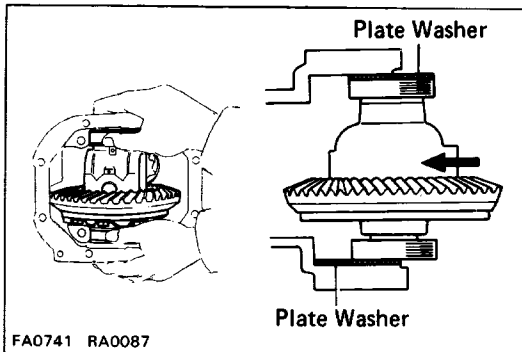

- (h) Place the other plate washer onto the differential case together with the outer race, and install the differential case with the outer race into the carrier.

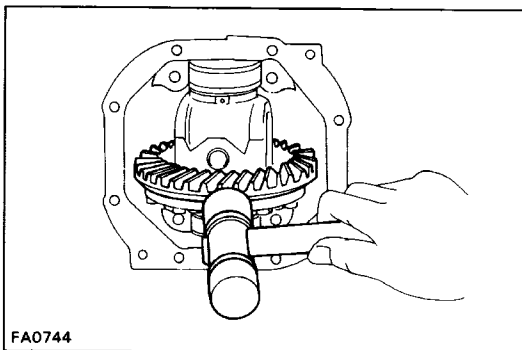

- (i) Using a plastic-faced hammer, snug down the washer and bearing by tapping the ring gear.

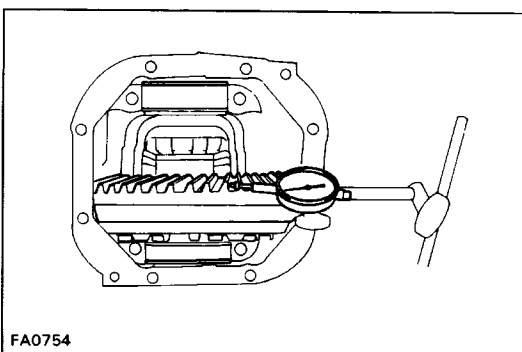

- (j) Using a dial indicator, measure the ring gear backlash.  
**Backlash: 0.13 – 0.18 mm (0.0051 – 0.0071 in.)**

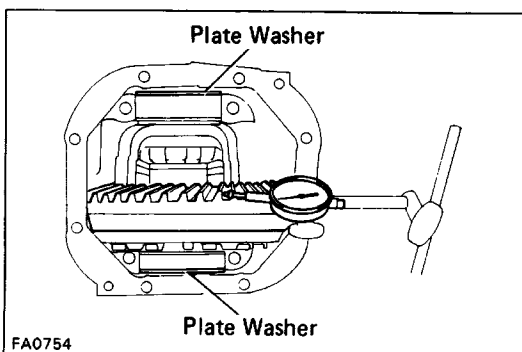

- (k) If not within specification, adjust by either increasing or decreasing the number of washers on both sides by an equal amount.  
HINT: There should be no clearance between the plate washer and case.  
Insure that there is ring gear backlash.



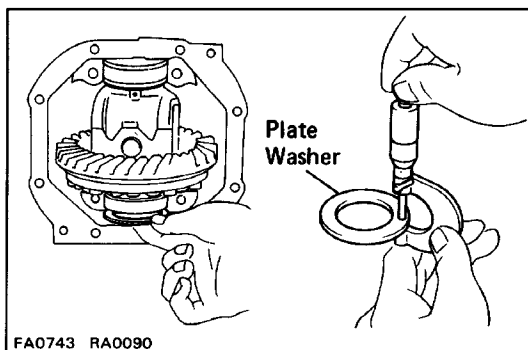

#### 4. ADJUST SIDE BEARING PRELOAD

- (a) Remove the ring gear teeth plate washer and measure the thickness.

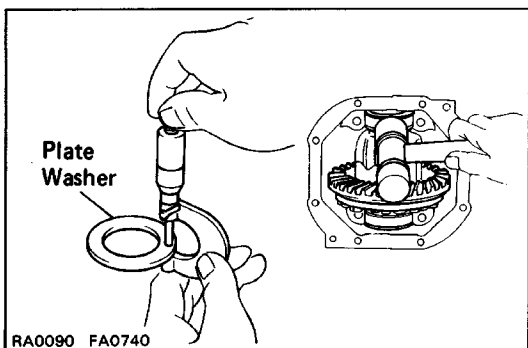

- (b) Using the backlash as a reference, install a new washer of 0.06 – 0.09 mm (0.0024 – 0.0035 in.) thicker than the washer removed.

HINT: Select a washer which can be pressed in 2/3 of the way with your finger.

- (c) Using a plastic-faced hammer, tap in the side washer.

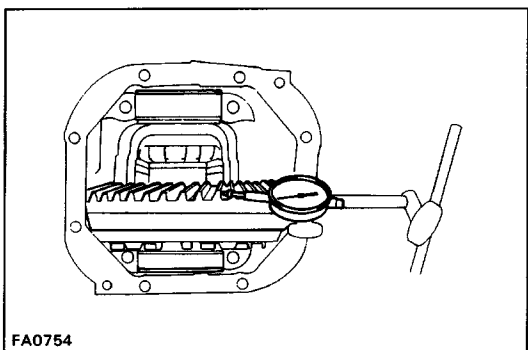

- (d) Recheck the ring gear backlash.

**Backlash: 0.13 – 0.18 mm (0.0051 – 0.0071 in.)**

- (e) If not within standard, adjust by either increasing or decreasing the washers on both sides by an equal amount.

HINT: The backlash will change about 0.02 mm (0.0008 in.) with 0.03 mm (0.0012 in.) alteration of the side washer.

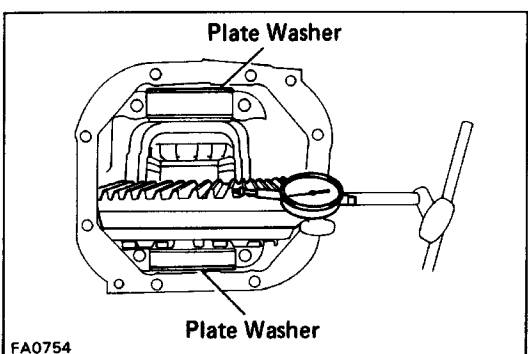

Washer thickness

Thickness mm (in.)	
2.57 – 2.59 (0.1012 – 0.1020)	2.93 – 2.95 (0.1154 – 0.1161)
2.60 – 2.62 (0.1024 – 0.1031)	2.96 – 2.98 (0.1165 – 0.1173)
2.63 – 2.65 (0.1035 – 0.1043)	2.99 – 3.01 (0.1177 – 0.1185)
2.66 – 2.68 (0.1047 – 0.1055)	3.02 – 3.04 (0.1189 – 0.1197)
2.69 – 2.71 (0.1059 – 0.1067)	3.05 – 3.07 (0.1201 – 0.1209)
2.72 – 2.74 (0.1071 – 0.1079)	3.08 – 3.10 (0.1213 – 0.1220)
2.75 – 2.77 (0.1083 – 0.1091)	3.11 – 3.13 (0.1224 – 0.1232)
2.78 – 2.80 (0.1094 – 0.1102)	3.14 – 3.16 (0.1236 – 0.1244)
2.81 – 2.83 (0.1106 – 0.1114)	3.17 – 3.19 (0.1248 – 0.1256)
2.84 – 2.86 (0.1118 – 0.1126)	3.20 – 3.22 (0.1260 – 0.1268)
2.87 – 2.89 (0.1130 – 0.1138)	3.23 – 3.25 (0.1272 – 0.1280)
2.90 – 2.92 (0.1142 – 0.1150)	

#### 5. INSTALL SIDE BEARING CAPS

Align the matchmarks on the cap and carrier.

Torque: 78 N-m (800 kgf-cm, 58 ft-lbf)

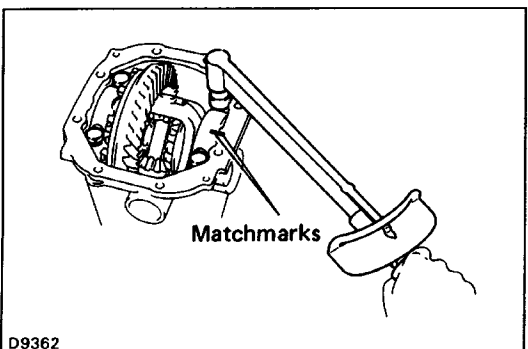

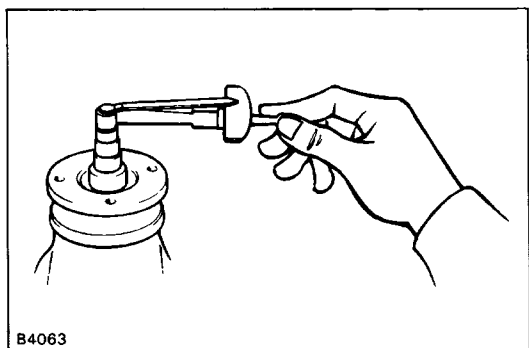

B4063

## 6. MEASURE TOTAL PRELOAD

Using a torque wrench, measure the total preload.

**Total preload (starting):**

**Add drive pinion preload**

**0.4 – 0.6 N-m**

**(4 – 6 kgf-cm, 3.5 – 5.2 in.-lbf)**

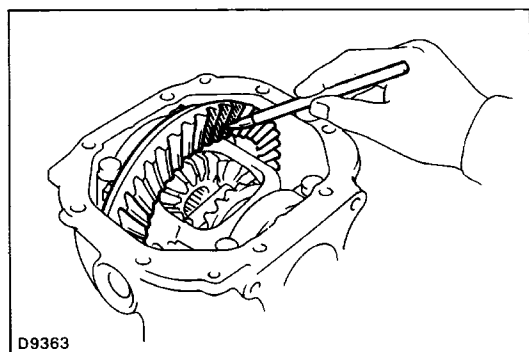

D9363

## 7. INSPECT TOOTH CONTACT BETWEEN RING GEAR AND DRIVE PINION

- Coat 3 or 4 teeth at three different positions on the ring gear with red lead .
- Hold the companion flange firmly and rotate the ring gear in both directions.
- Inspect the tooth pattern.

If the teeth are not contacting properly, use the following chart to select a proper washer for correction.

Washer thickness

Thickness mm (in.)	
2.24 (0.0882)	2.51 (0.0988)
2.27 (0.0894)	2.54 (0.1000)
2.30 (0.0906)	2.57 (0.1012)
2.33 (0.0917)	2.60 (0.1024)
2.36 (0.0929)	2.63 (0.1035)
2.39 (0.0941)	2.66 (0.1047)
2.42 (0.0953)	2.69 (0.1059)
2.45 (0.0965)	2.72 (0.1071)
2.48 (0.0976)	

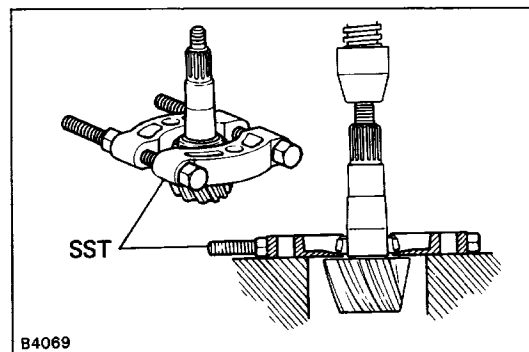

B4069

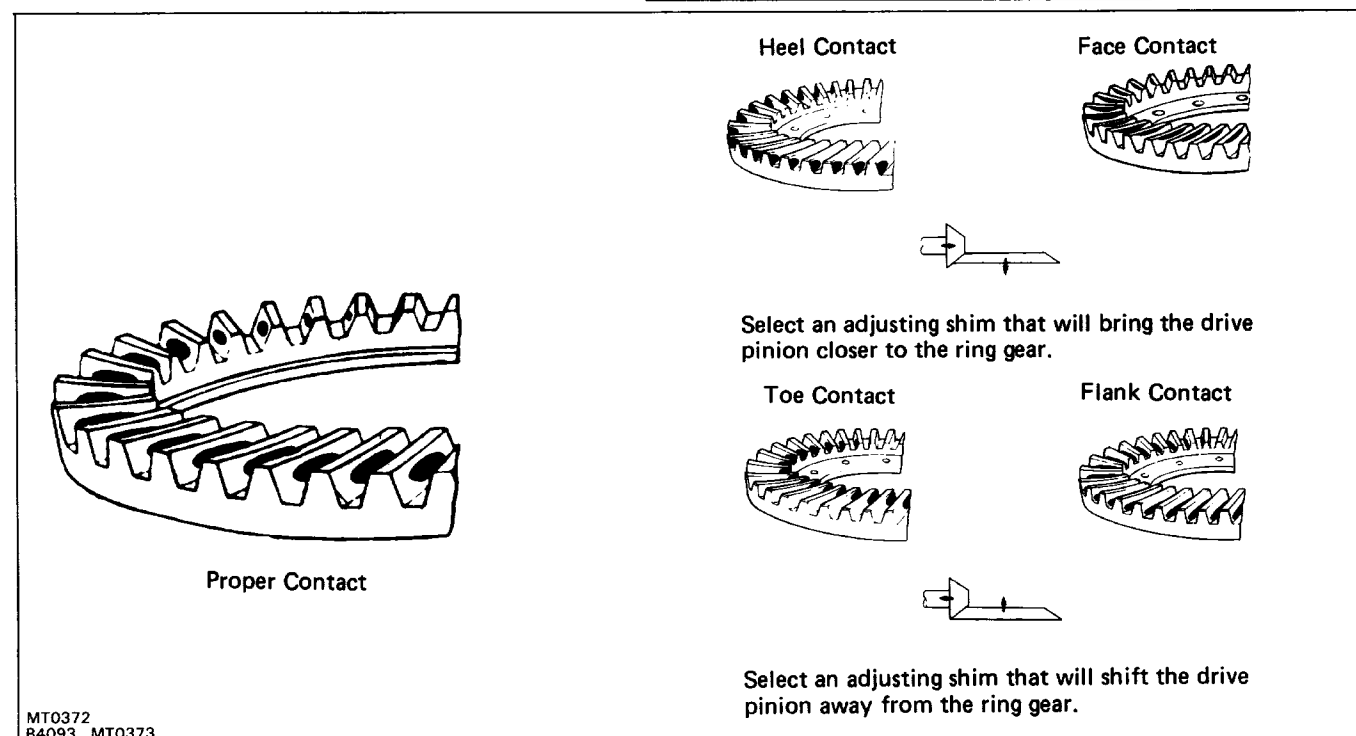

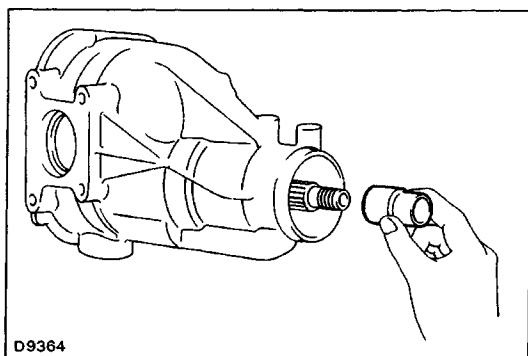
**8. REMOVE COMPANION FLANGE**

(See step 11 on page SA-68)

**9. REMOVE FRONT BEARING**

(See step 12 on page SA-69)

**10. INSTALL NEW BEARING SPACER AND FRONT BEARING**

- (a) Install a new bearing spacer on the drive pinion.
- (b) Install the front bearing on the drive pinion.

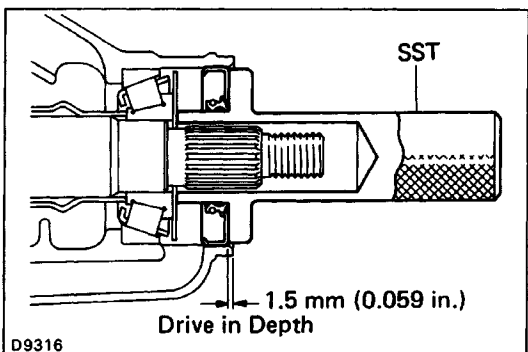
**11. INSTALL OIL SLINGER AND NEW OIL SEAL**

- (a) Install the oil slinger.
- (b) Using SST, drive in a new oil seal.

SST 09554-3001 1

**Oil seal drive in depth: 1.5 mm (0.059 in.)**

- (c) Apply MP grease to the oil seal lip.

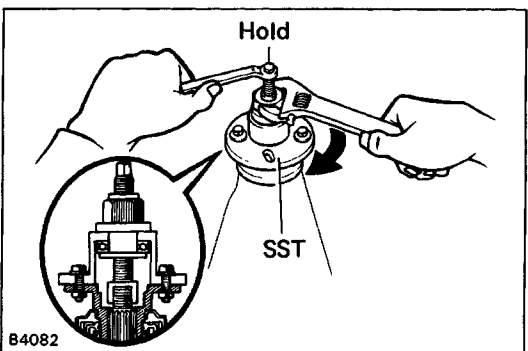
**12. INSTALL COMPANION FLANGE**

- (a) Using SST, install the companion flange on the shaft.

SST 09557-22022 (09557-22030)

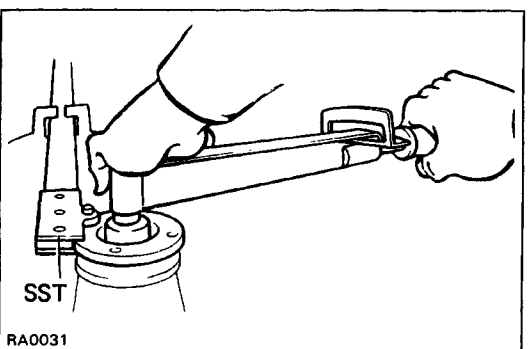

- (b) Coat the threads of a new nut with MP grease.
- (c) Using SST to hold the flange, tighten the nut.

Torque the nut.

SST 09330-00021

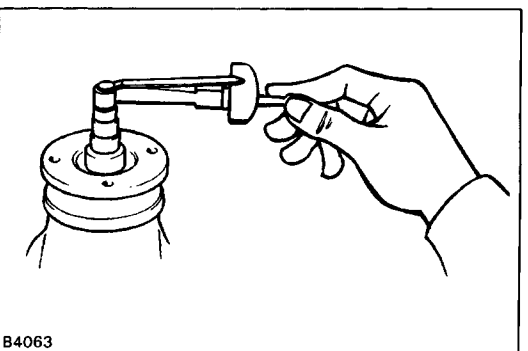
**Torque: 120 N-m (1,225 kgf-cm, 89 ft-lbf)****13. CHECK FRONT BEARING PRELOAD**

Using a torque meter, measure the preload of the back-lash between the drive pinion and ring gear.

**Preload (starting):****New bearing**

1.2 – 1.9 N-m

(12 – 19 kgf-cm, 10.4 – 16.5 in.-lbf)

**Reused bearing**

0.6 – 1.0 N-m

(6 – 10 kgf-cm, 5.2 – 8.7 in.-lbf)

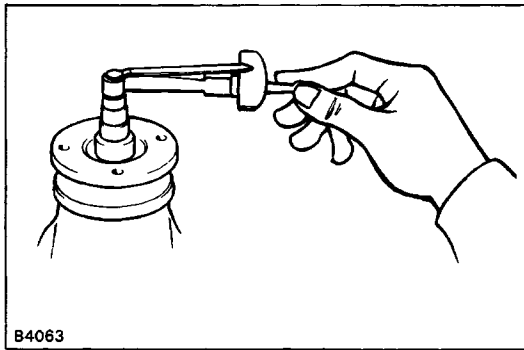

- (a) If the preload is greater than specification, replace the bearing spacer.
- (b) If the preload is less than specification, retighten the nut 13 N-m (130 kgf-cm, 9 ft-lbf) a little at a time until the specified preload is reached.

**Maximum torque: 223 N-m (2,275 kgf-cm, 165 ft-lbf)**

If the maximum torque is exceeded while retightening the nut, replace the bearing spacer and repeat the preload procedure. Do not back off the pinion nut to reduce the preload.

#### 14. CHECK RUNOUT OF COMPANION FLANGE

Using a dial indicator, measure the vertical and lateral runout of the companion flange.

**Maximum vertical runout: 0.10 mm (0.0039 in.)**

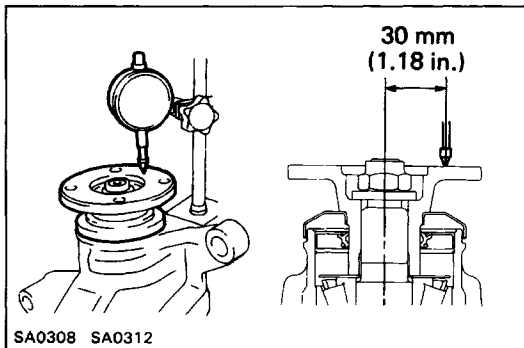

**Maximum lateral runout: 0.10 mm (0.0039 in.)**

If the runout is greater than maximum, inspect the bearings.

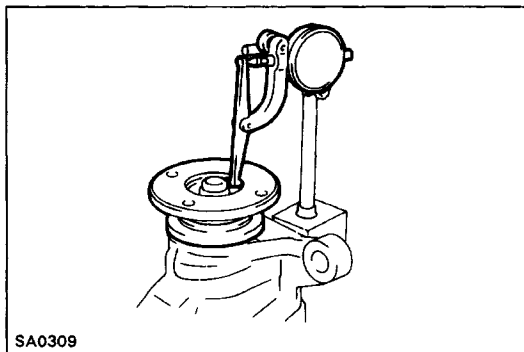

#### 15. STAKE DRIVE PINION NUT

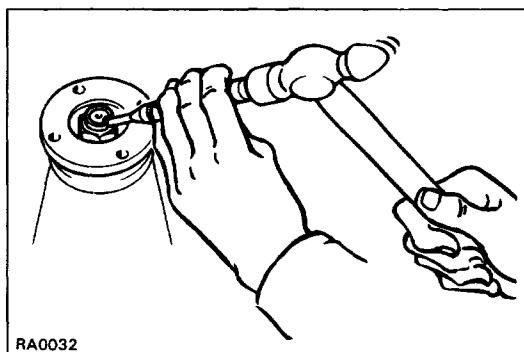

#### 16. INSTALL NEW SIDE GEAR SHAFT OIL SEAL

- (a) Coat the oil seal lip with MP grease.
- (b) Using SST, drive in the oil seal until it is flush with the carrier end surface.

SST 09550-22011 (09550-00020, 09550-00031)

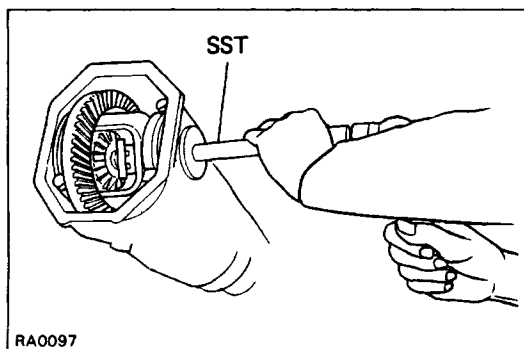

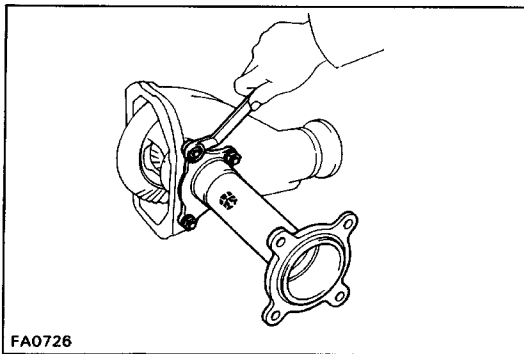

### 17. INSTALL DIFFERENTIAL TUBE

Install the differential tube to the differential carrier with the four bolts.

**Torque: 88 N-m (900 kgf-cm, 65 ft-lbf)**

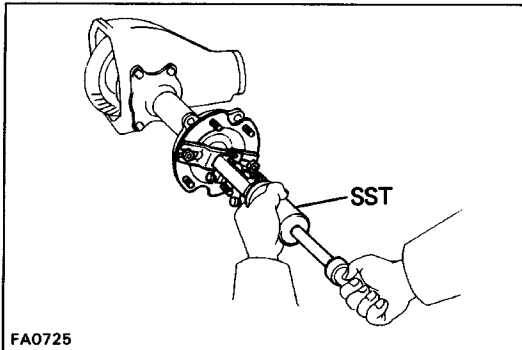

### 18. INSTALL SIDE GEAR SHAFTS

- Before installing the shafts, replace the snap ring.
- Using SST, install the side gear shafts to the differential carrier.

SST 09910-00015

(09911-00011, 09912-00010, 09914-00011)

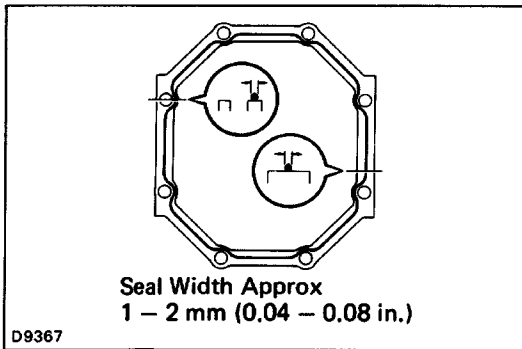

### 19. INSTALL DIFFERENTIAL CARRIER COVER

- Remove any packing material and be careful not to drop oil on the contacting surface of the differential carrier or carrier cover.
- Apply seal packing to the carrier cover.

**Seal packing: Part No. 08826-00090, THREE BOND 1281 or equivalent**

**HINT:** Install the carrier cover within ten minutes after applying seal packing.

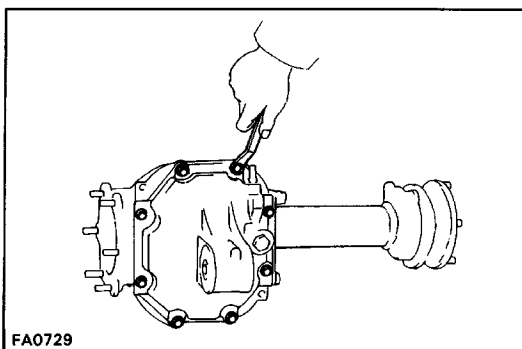

- Install and torque the bolts.

**Torque: 47 N-m (475 kgf-cm, 34 ft-lbf)**

# Disassembly and Assembly of Differential (with A.D.D.)

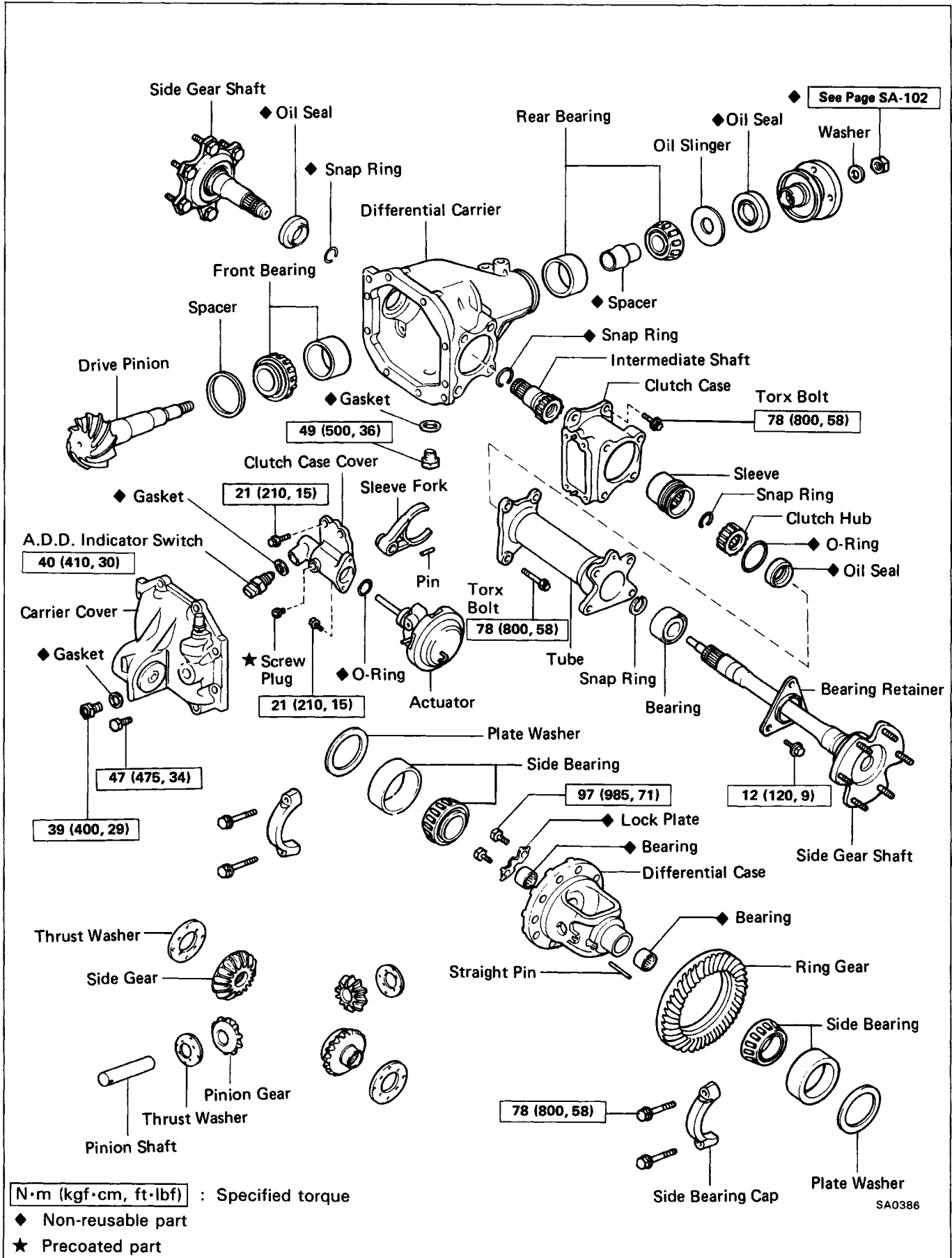

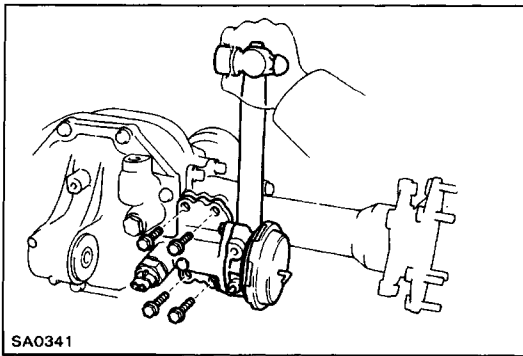

## DISASSEMBLY OF DIFFERENTIAL

### 1. REMOVE ACTUATOR

- (a) Remove the four bolts.
- (b) Using a hammer, remove the actuator.

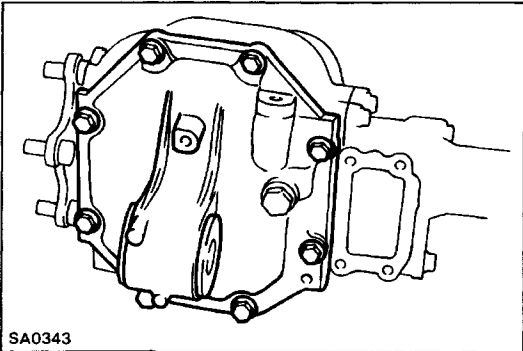

### 2. REMOVE DIFFERENTIAL CARRIER COVER

Remove the eight bolts and tap off the cover with a plastic-faced hammer.

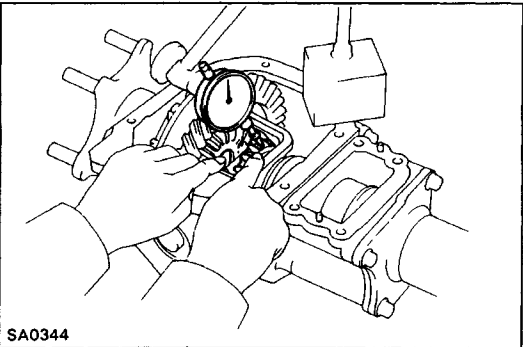

### 3. CHECK SIDE GEAR BACKLASH

Measure the side gear backlash while holding one pinion gear toward the case.

**Standard backlash: 0.05 – 0.20 mm**

**(0.0020 – 0.0079 in.)**

If the backlash is out of specification, install the correct thrust washers. (See page [SA-90](#))

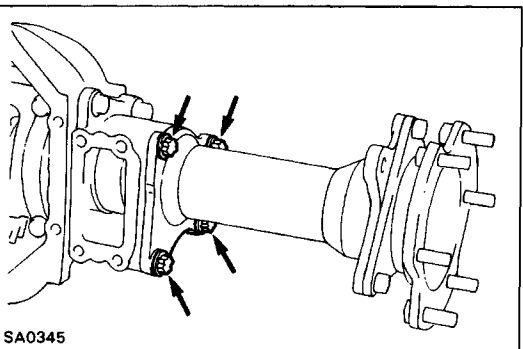

### 4. REMOVE LH SIDE GEAR SHAFT WITH TUBE

- (a) Remove the four torx bolts.  
Torx wrench: E14 (Part No. 09044-00010 or locally manufactured tool)

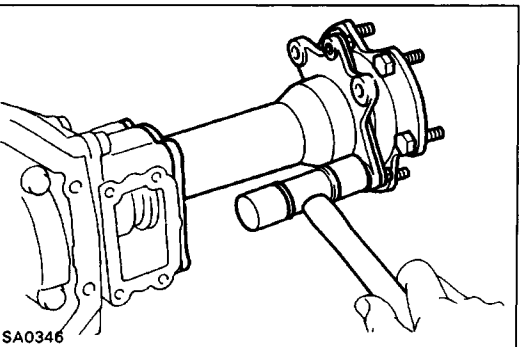

- (b) Using a plastic-faced hammer, tap on the tube to remove it.

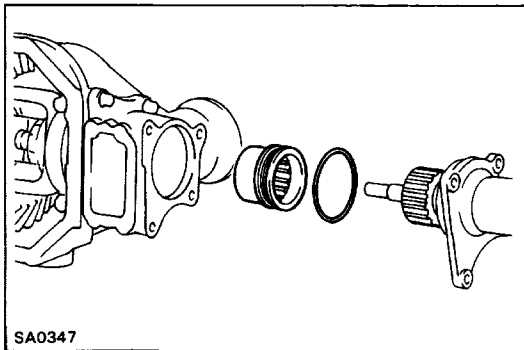

- (c) Remove the sleeve.  
 (d) Remove the O-ring from the tube.

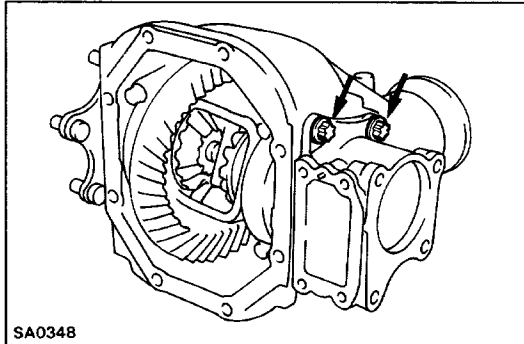

## 5. REMOVE CLUTCH CASE

- (a) Remove the two torx bolts.  
 Torx wrench: E14 (Part No. 09044-00010 or locally manufactured tool)

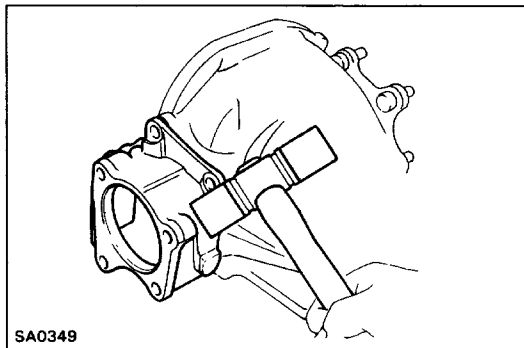

- (b) Using a plastic-faced hammer, tap on the clutch case to remove it.

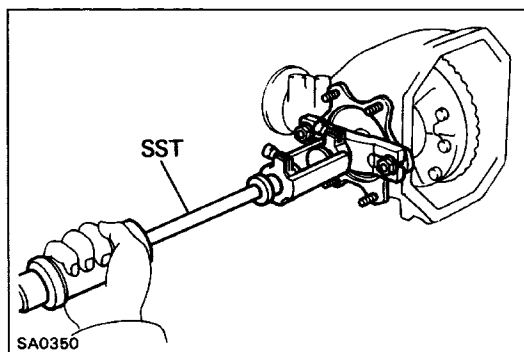

## 6. REMOVE RH SIDE GEAR SHAFT

- Using SST, pull off the RH side gear shaft.  
 SST 09910-00015  
 (09911-00011, 09912-00010, 09914-00011)

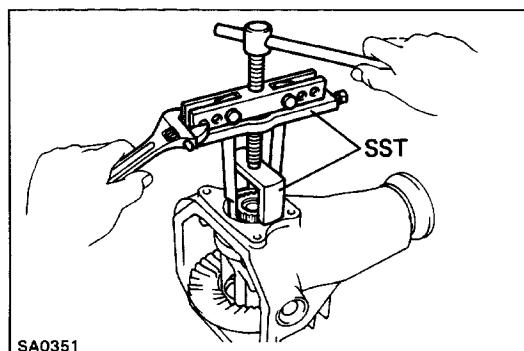

## 7. REMOVE INTERMEDIATE SHAFT

- Using SST, pull off the intermediate shaft.  
 SST 09350-20015 (09369-20040), 09950-20017



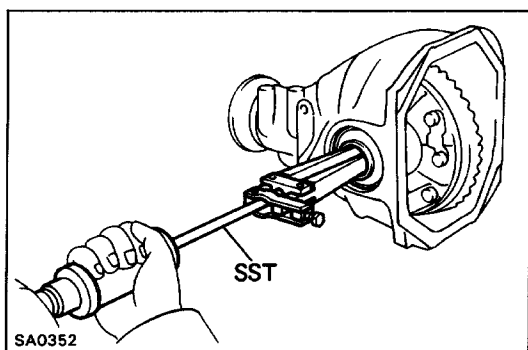

## 8. REMOVE RH SIDE OIL SEAL

Using SST, remove the oil seal.  
SST 09308-00010

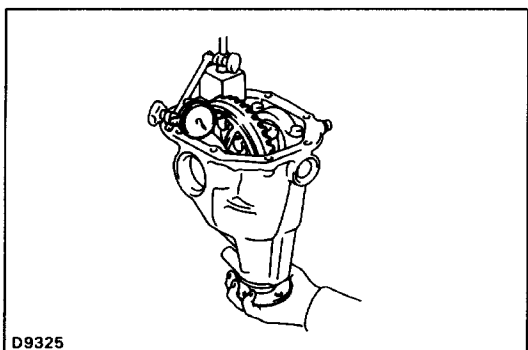

## 9. CHECK RING GEAR RUNOUT

Using a dial indicator, measure the ring gear runout.  
**Maximum runout: 0.07 mm (0.0028 in.)**

If the runout is greater than maximum, replace the ring gear and drive pinion as a set.

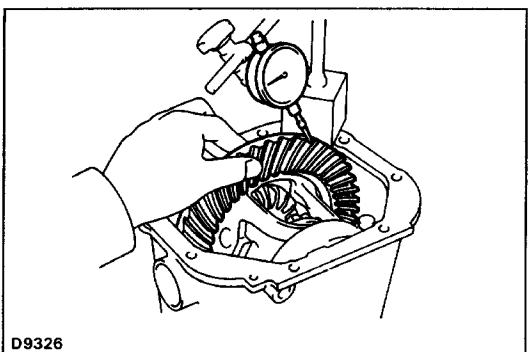

## 10. CHECK RING GEAR BACKLASH

(a) Fix the dial indicator on the tooth surface at a 90° angle.

(b) Holding the drive pinion flange, measure the ring gear backlash.

**Ring gear backlash: 0.13 – 0.18 mm  
(0.0051 – 0.0071 in.)**

If the backlash is not within specification, adjust the ring gear backlash.

HINT: Measure from three or more places on the circumference of the ring gear.

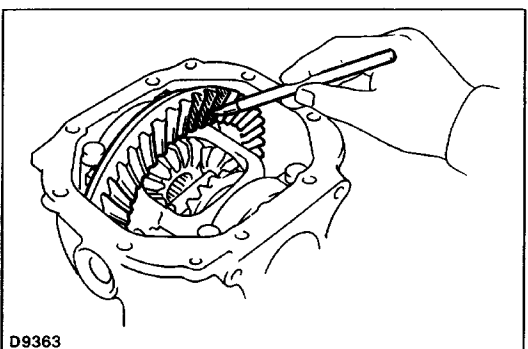

## 11. INSPECT TOOTH CONTACT BETWEEN RING GEAR AND DRIVE PINION (SEE STEP 7 ON PAGE SA-100)

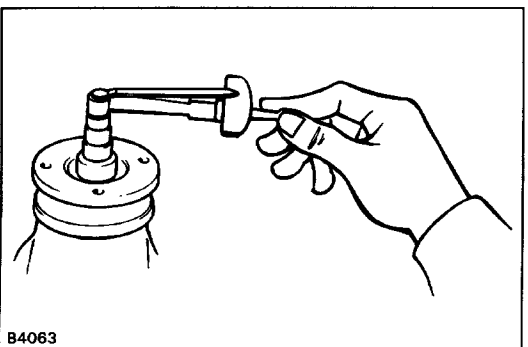

## 12. MEASURE DRIVE PINION PRELOAD

Using a torque gauge, measure the preload of the backlash between the drive pinion and ring gear.

**Preload (starting):  
0.6 – 1.0 N-m (6 – 10 kgf-cm, 5.2 – 8.7 in.-lbf)**

## 13. CHECK TOTAL PRELOAD

Using a torque gauge, measure the total preload.

**Total preload (starting):  
Add drive pinion preload  
0.4 – 0.6 N-m  
(4 – 6 kgf-cm, 3.5 – 5.2 in.-lbf)**

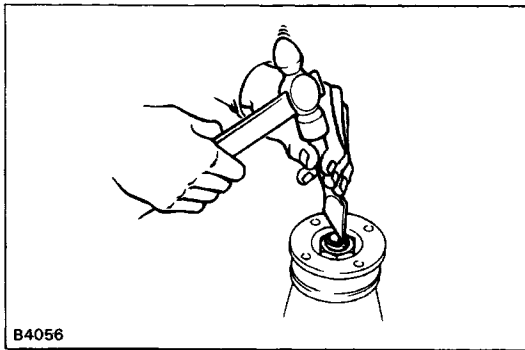
**14. REMOVE COMPANION FLANGE**

- (a) Using a hammer and chisel, loosen the staked part of the nut.

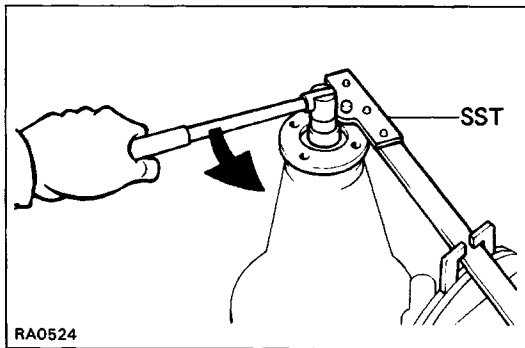

- (b) Using SST to hold the flange, remove the nut.  
SST 09330-00021

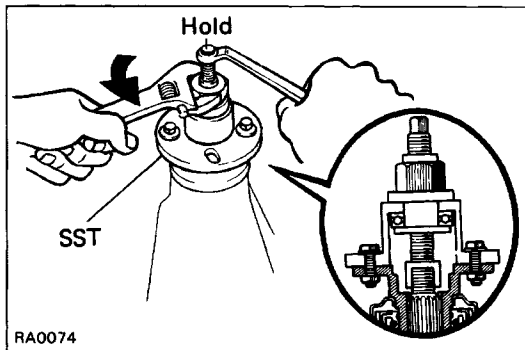

- (c) Using SST, remove the companion flange.  
SST 09557-22022 (09557-22030)

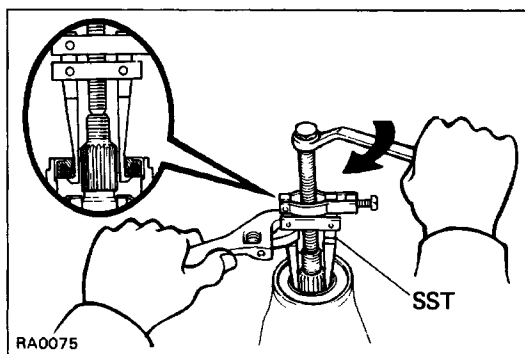
**15. REMOVE OIL SEAL AND OIL SLINGER**

- (a) Using SST, remove the oil seal from the housing.  
SST 09308-10010  
(b) Remove the oil slinger.

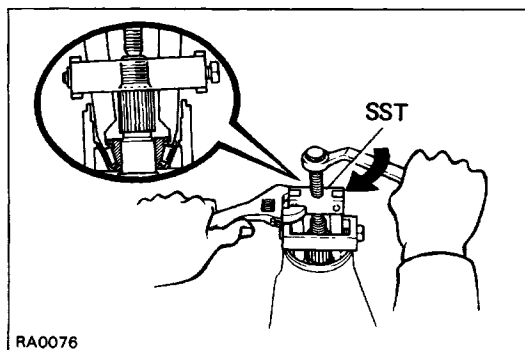
**16. REMOVE REAR BEARING AND BEARING SPACER**

- (a) Using SST, remove the rear bearing from drive pinion.  
SST 09556-30010  
(b) Remove the bearing spacer.  
If the rear bearing is damaged or worn, replace the bearing.

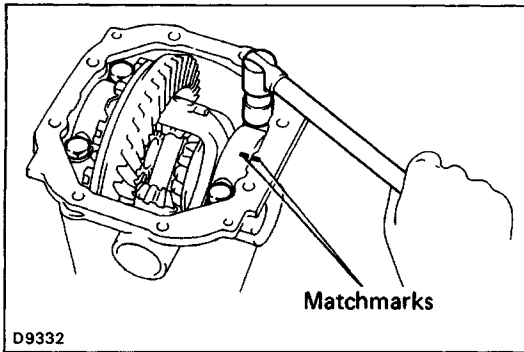
**17. REMOVE DIFFERENTIAL CASE AND RING GEAR**

- (a) Place matchmarks on the bearing cap and differential carrier.
- (b) Remove the two bearing caps.

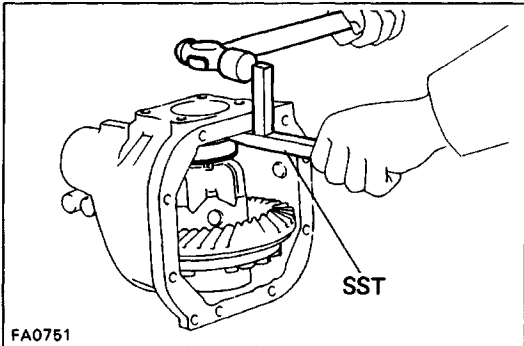

- (c) Using SST and a hammer, remove the two side bearing preload adjusting plate washers.  
SST 09504-22011  
HINT: Measure the adjusting plate washer and note the thickness.

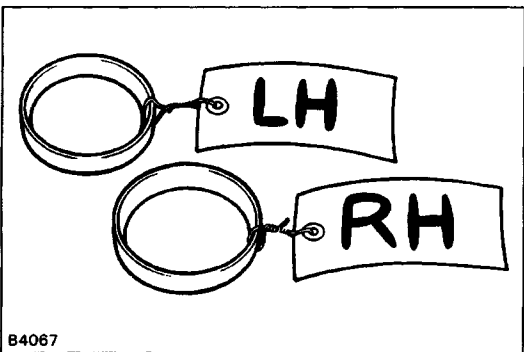

- (d) Remove the differential case with bearing outer race from the carrier.  
HINT: Tag the bearing outer races to show the location for reassembly.

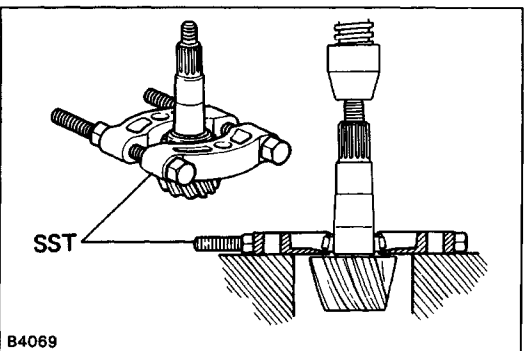
**18. REMOVE DRIVE PINION FROM DIFFERENTIAL CARRIER****INSPECTION AND REPLACEMENT OF DIFFERENTIAL****1. REPLACE DRIVE PINION FRONT BEARING**

- (a) Using SST, press out the front bearing from the drive pinion.  
SST 09950-00020  
HINT: If the drive pinion or ring gear are damaged, replace them as a set.

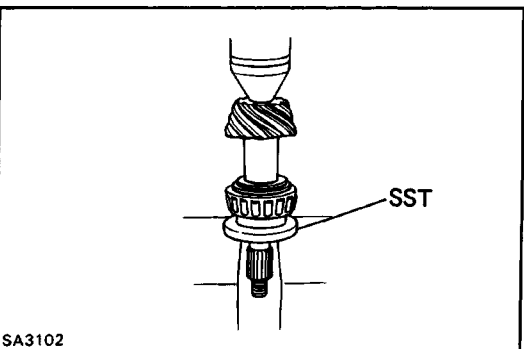

- (b) Install the washer on the drive pinion.
- (c) Using SST, press in the front bearing onto the drive pinion.  
SST 09506-30012

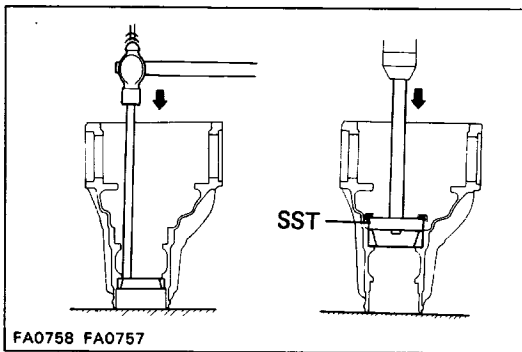

## 2. REPLACE DRIVE PINION FRONT AND REAR BEARING OUTER RACES

- (a) Using a brass bar and hammer, drive out the outer race.
- (b) Using SST, drive in a new outer race.  
SST 09608-35014  
Front outer race (09608-06020, 09608-06120)  
Rear outer race (09608-06020, 09608-06110)

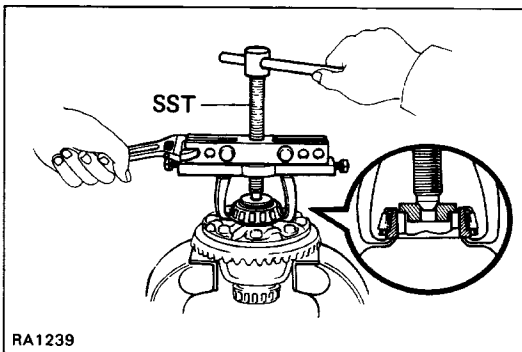

## 3. REMOVE SIDE BEARING FROM DIFFERENTIAL CASE

- Using SST, remove the side bearing from the differential case.  
SST 09950-20017  
HINT: Fix the claws of SST to the notches in the differential case.

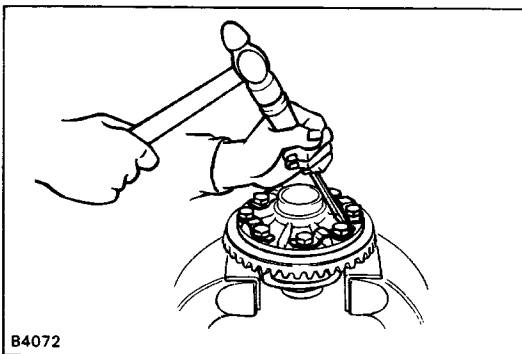

## 4. REMOVE RING GEAR

- (a) Remove the ring gear set bolts and lock plates.
- (b) Place matchmarks on the ring gear and differential case.
- (c) Using a plastic-faced hammer, tap on the ring gear to separate it from the differential case.

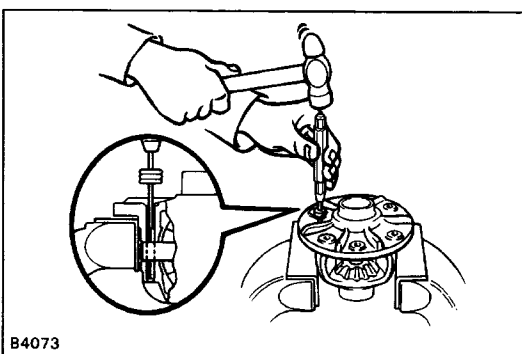

## 5. DISASSEMBLE DIFFERENTIAL CASE

- (a) Using a hammer and punch, drive out the straight pin. Remove the pinion shaft, two pinion gears, two side gears and four thrust washers.

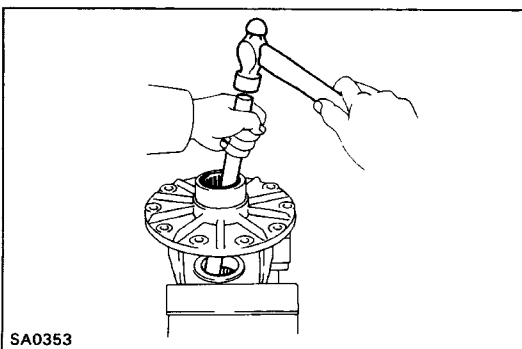

- (b) Using a hammer and brass bar, drive out the needle bearings.

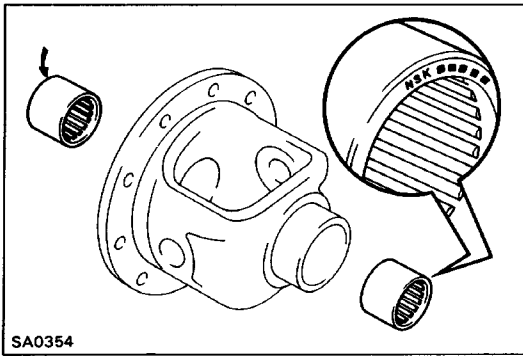

## 6. ASSEMBLE DIFFERENTIAL CASE

- (a) Using SST, press the new needle bearing into the differential case.

**NOTICE:** Press in the bearings, with the engraved side of each bearing facing outward from the differential case.

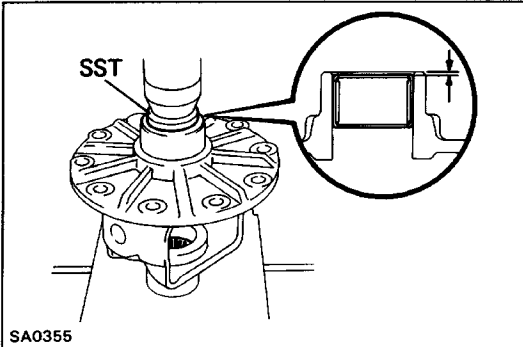

**Bearing press in depth: 2.0 mm 10.079 in.)**

SST 09950-20017

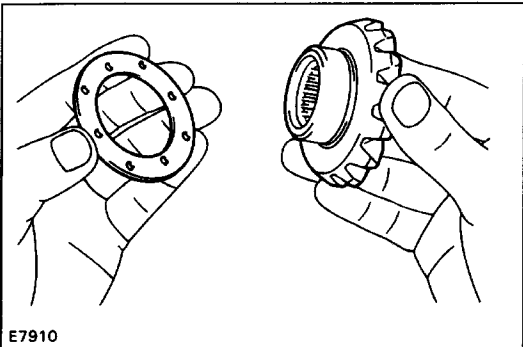

- (b) Install the thrust washers to the side gears.  
 (c) Install the side gears with thrust washers and pinion gears with thrust washers.  
 (d) Install the pinion shaft.  
 (e) Check the side gear backlash.

Measure the side gear backlash while holding one pinion gear toward the case.

**Backlash: 0.05 – 0.20 mm (0.0020 – 0.0079 in.)**

If the backlash is not within specification, install the side gear thrust washers of different thickness.

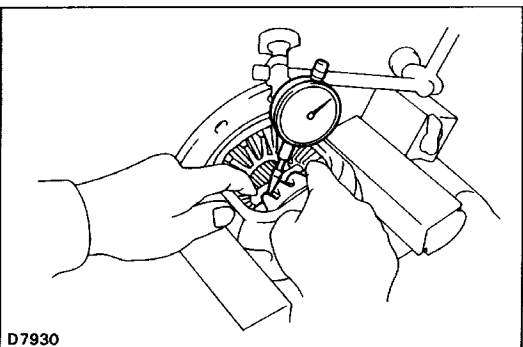

Thickness	mm (in.)
0.96 – 1.04	(0.0378 – 0.0409)
1.06 – 1.14	(0.0417 – 0.0449)
1.16 – 1.24	(0.0457 – 0.0488)
1.26 – 1.34	(0.0496 – 0.0528)

**HINT:** Use washers of same thickness on both the right and left sides.

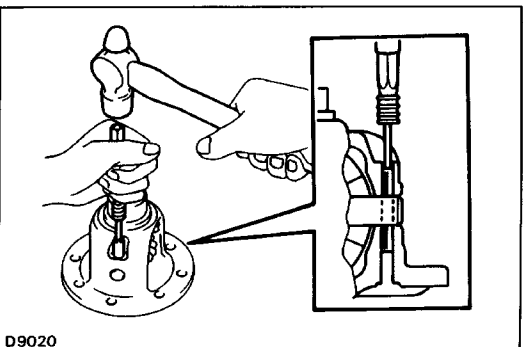

- (f) Using a hammer and punch, drive in the straight pin through the case and hole in the pinion shaft.

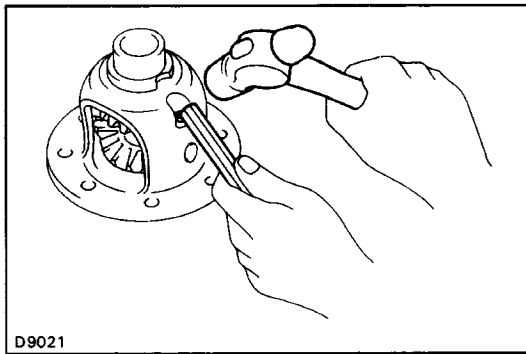

(g) Stake the case.

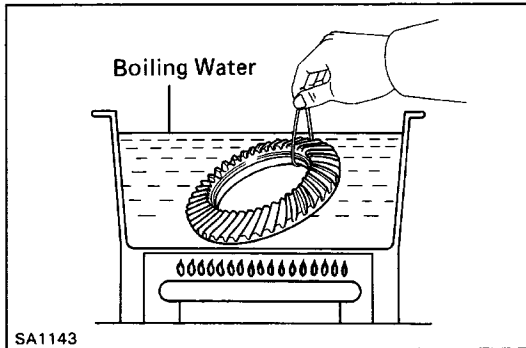

## 7. INSTALL RING GEAR ON DIFFERENTIAL CASE

(a) Clean the contact surfaces of the differential case and ring gear.

(b) Heat the ring gear in boiling water.

(c) After the moisture on the ring gear has completely evaporated, quickly install the ring gear to the differential case.

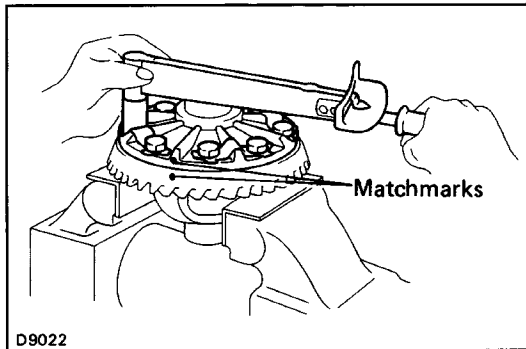

(d) Align the matchmarks on the ring gear and differential case.

(e) Coat the ring gear set bolts with gear oil.

(f) Temporarily install the lock plates and set bolts.

(g) After the ring gear cools down enough, tighten the set bolts uniformly and a little at a time.

**Torque: 97 N-m(985 kgf-cm, 71 ft-lbf)**

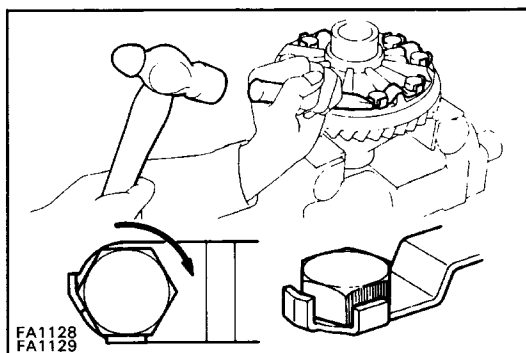

(h) Using a hammer and drift punch, stake the lock plates.

**HINT:** Stake one claw flush with the flat surface of the nut. For the claw contacting the protruding portion of the nut, stake only the half on the tightening side.

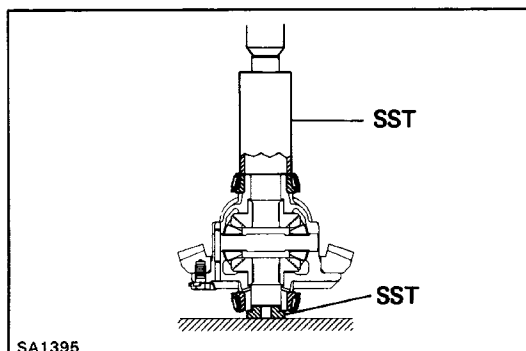

## 8. INSTALL SIDE BEARINGS

Using a press and SST, install the side bearings to the differential case.

SST 09226-10010, 09950-20017

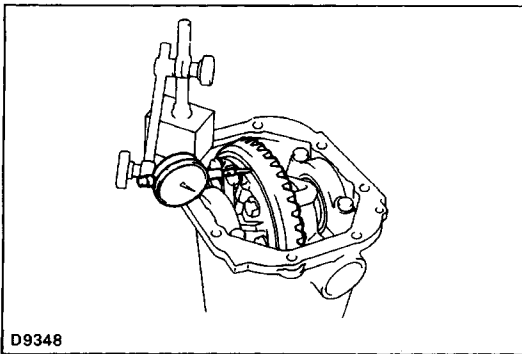

## 9. CHECK RING GEAR RUNOUT

- Install the differential case onto the carrier and install the plate washers to where there is no play in the bearing. (See page SA-97)
- Install bearing caps. (See page SA-99)
- Using a dial indicator, measure the runout of ring gear.

**Maximum runout: 0.07 mm (0.0028 in.)**

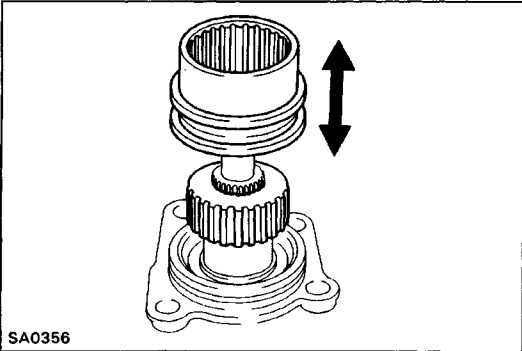

## INSPECTION AND REPLACEMENT OF LH SIDE GEAR SHAFT

### 1. INSPECT CLUTCH HUB AND CLUTCH SLEEVE

- Check the wear and damage of the clutch hub and clutch sleeve.  
If necessary, replace them.
- Check that the clutch sleeve slides smoothly on the clutch hub.

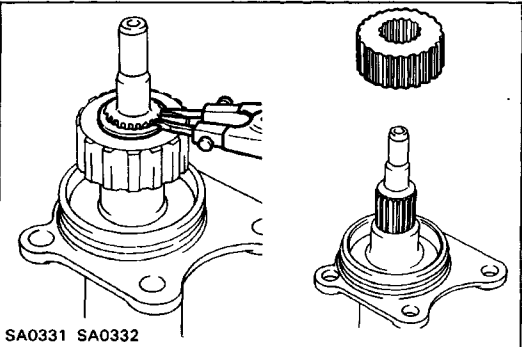

### 2. REMOVE CLUTCH HUB

- Using a snap ring expander, remove the snap ring.
- Remove the clutch hub from the side gear shaft.

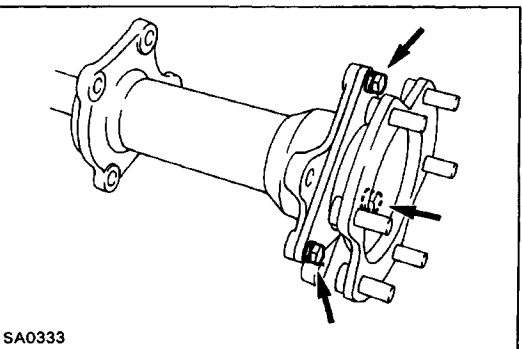

### 3. REMOVE SIDE GEAR SHAFT FROM TUBE

- Remove the three bearing retainer bolts.
- Remove the side gear shaft from the tube.

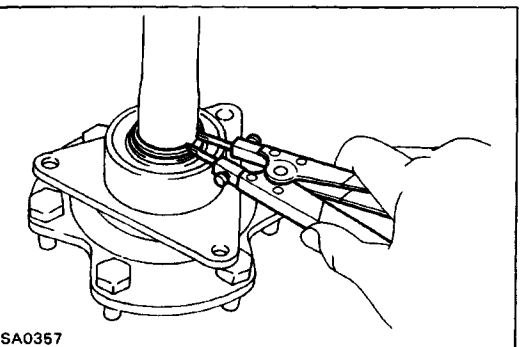

### 4. REPLACE LH SIDE GEAR SHAFT BEARING

- Using a snap ring expander, remove the snap ring.

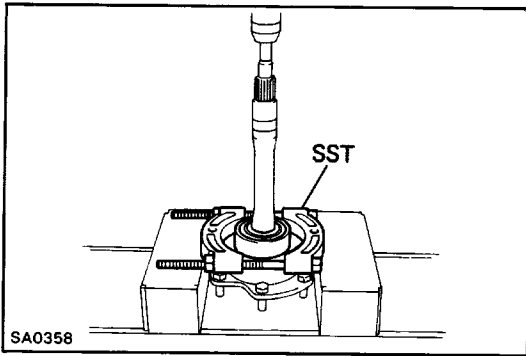

- (b) Using a press and SST, remove the bearing.  
SST 09950-00020

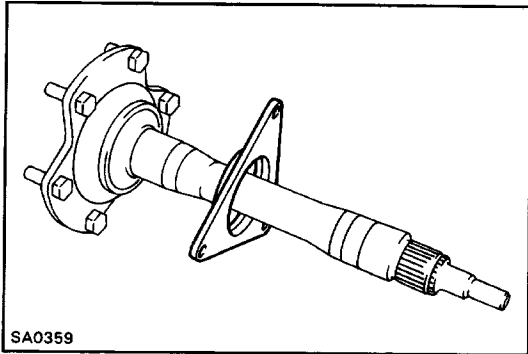

- (c) Remove the bearing retainer.  
(d) Install the bearing retainer.

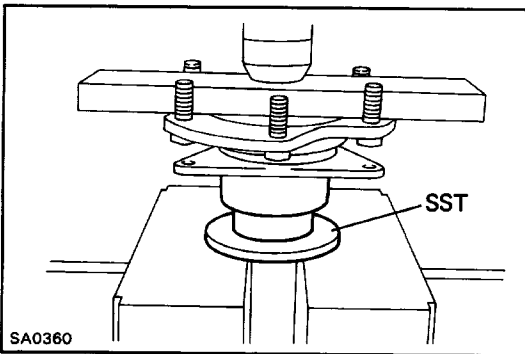

- (e) Using a press and SST, install the new bearing.  
SST 09316-60010 (09316-00040)  
**NOTICE: Be careful not to damage the bearing retainer.**

## 5. REPLACE SIDE OIL SEAL (See page SA-62)

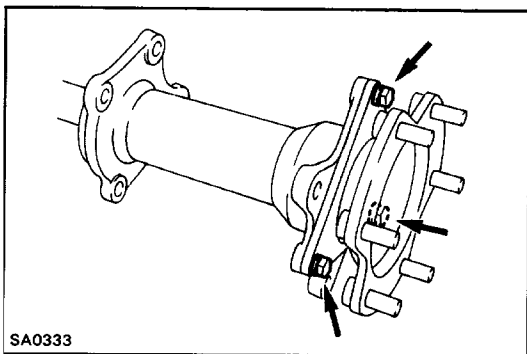

## 6. INSTALL SIDE GEAR SHAFT

- (a) Install the side gear shaft into the tube.  
(b) Tighten the three bearing retainer bolts.

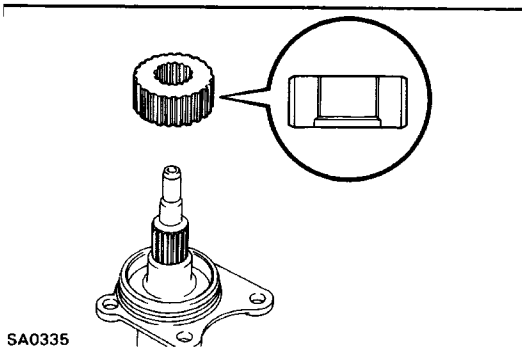

## 7. INSTALL CLUTCH HUB

- (a) Install the clutch hub to the shaft.



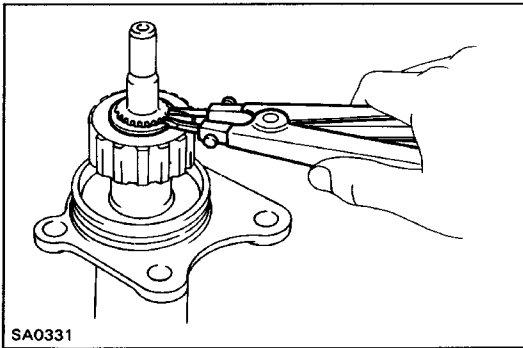

(b) Using a snap ring expander, install the snap ring.

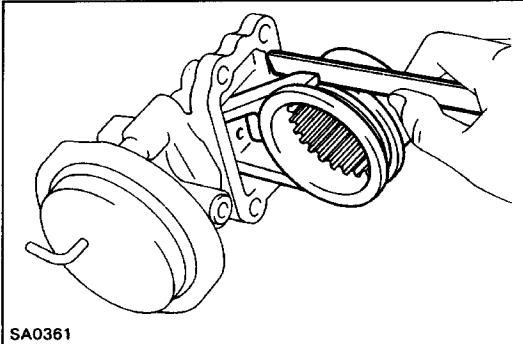

## INSPECTION AND REPLACEMENT OF ACTUATOR

### 1. MEASURE CLEARANCE OF SLEEVE FORK AND CLUTCH SLEEVE

Using a feeler gauge, measure the clearance between the sleeve fork and clutch sleeve.

**Maximum clearance: 0.35 mm (0.0138 in.)**

If the clearance exceeds the limit, replace the fork or sleeve.

### 2. INSPECT A.D.D. ACTUATOR

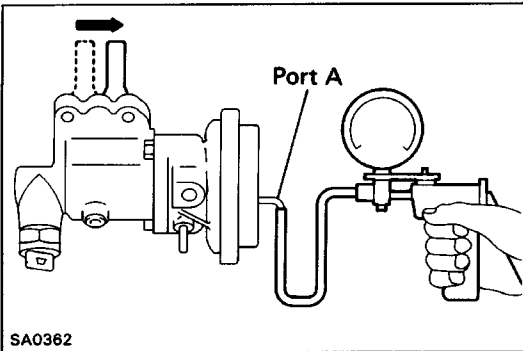

(a) Check that the sleeve fork moves to the actuator side when a vacuum of 500 mmHg (19.69 in.Hg, 66.7 kPa) is applied to port A. Also check that the vacuum does not leak.

If not, replace the actuator.

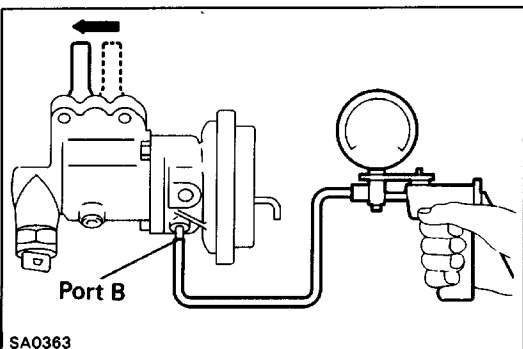

(b) Check that the sleeve fork moves away from the actuator when a vacuum of 500 mmHg (19.69 in.Hg, 66.7 kPa) is applied to port B. Also check that the vacuum does not leak.

If not, replace the actuator.

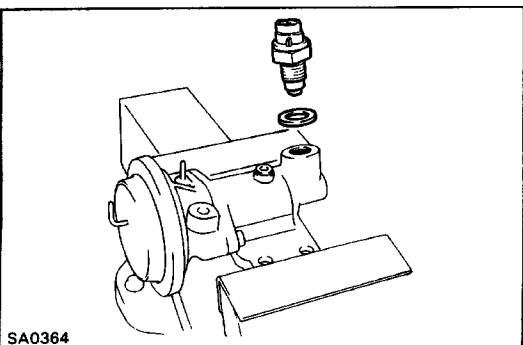

### 3. REMOVE A.D.D. INDICATOR SWITCH

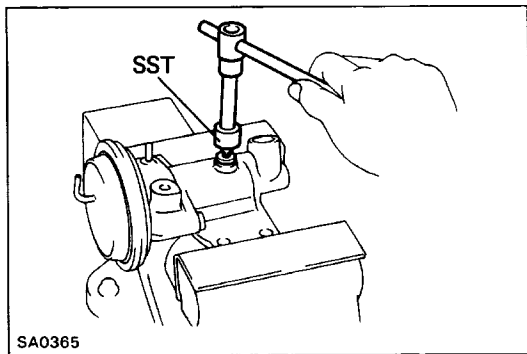

#### 4. REMOVE SLEEVE FORK PIN

- (a) Using SST, remove the screw plug.  
SST 09313-30021

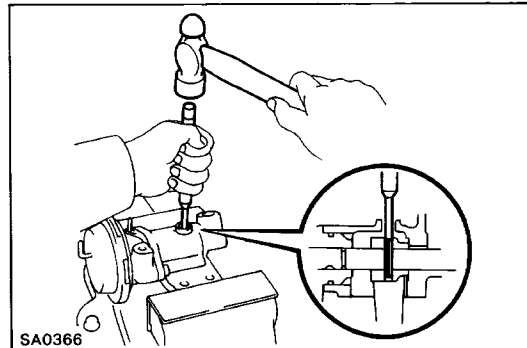

- (b) Using a hammer and punch, drive out the pin through the hole of clutch case cover.

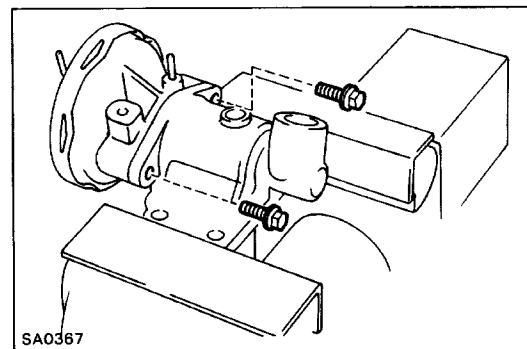

#### 5. SEPARATE ACTUATOR FROM CLUTCH CASE COVER AND REMOVE SLEEVE FORK

- (a) Remove the two bolts.

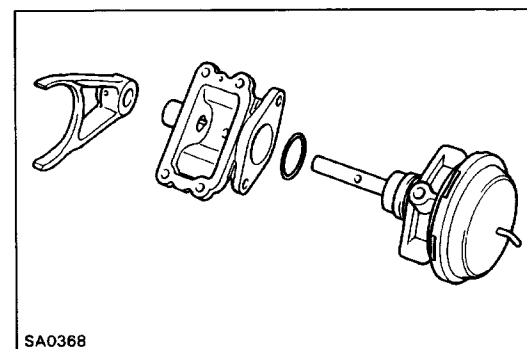

- (b) Separate the actuator from clutch case cover and remove the sleeve fork.  
(c) Remove the O-ring from actuator.

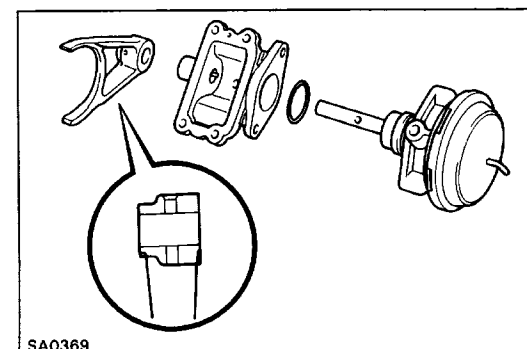

#### 6. INSTALL SLEEVE FORK AND ACTUATOR INTO CLUTCH CASE COVER

- (a) Install a new O-ring to the actuator.  
(b) Coat the O-ring with MP grease.  
(c) Place the sleeve fork and install the actuator to the clutch case cover.

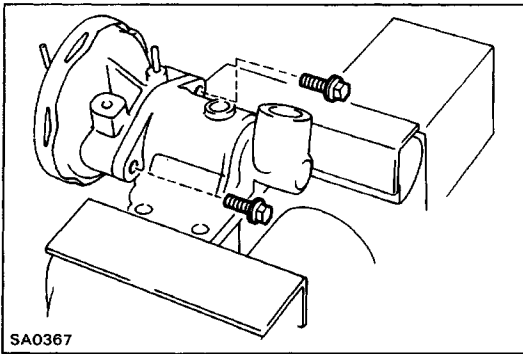

- (d) Tighten the two bolts.  
**Torque: 21 N-m (210 kgf-cm, 15 ft-lbf)**

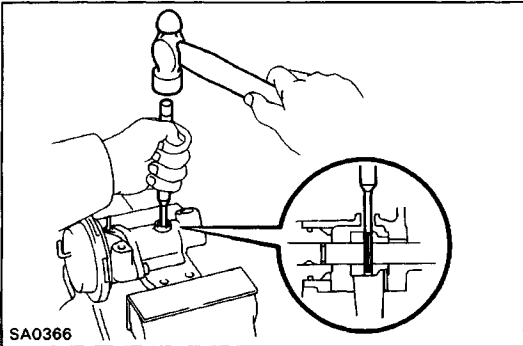

## 7. INSTALL SLEEVE FORK PIN

- (a) Using a hammer and punch, drive in the pin through the hole of clutch case cover.

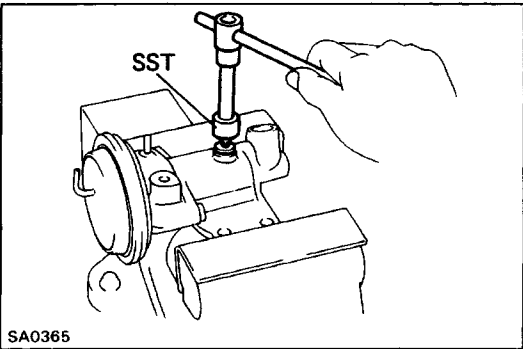

- (b) Coat the threads of screw plug with sealer.  
**Sealer: Part No. 08826-00090, THREE BOND 1281 or equivalent**
- (c) Using SST, install the screw plug.  
**Torque: 20 N-m (200 kgf-cm, 14 ft-lbf)**  
**SST 09313-30021**

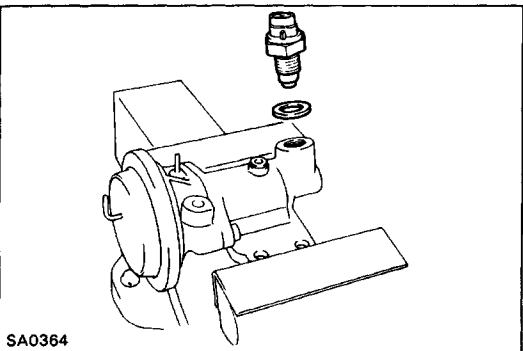

## 8. INSTALL A.D. D. INDICATOR SWITCH

- Install a new gasket and indicator switch.  
**Torque: 40 N-m (410 kgf-cm, 30 ft-lbf)**

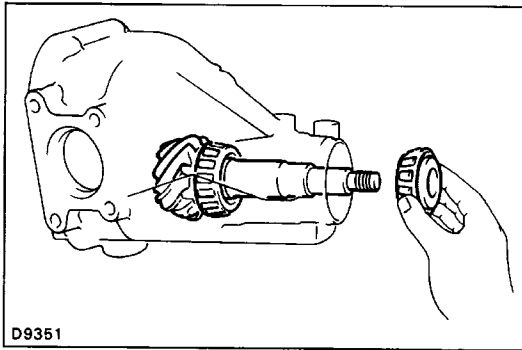

## ASSEMBLY OF DIFFERENTIAL

(See page SA-83)

### 1. TEMPORARILY ADJUST DRIVE PINION PRELOAD

(a) Install the following parts.

- Drive pinion
- Front bearing

HINT: Assemble the spacer and oil seal after adjusting the gear contact pattern.

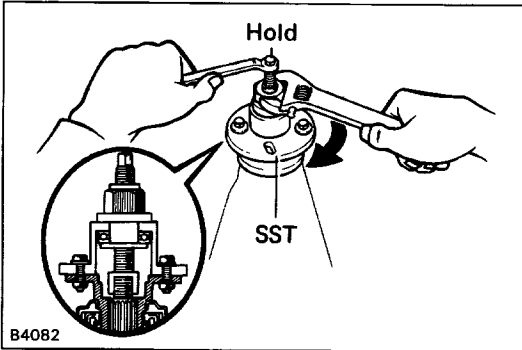

(b) Install the companion flange with SST.

Coat the threads of the nut with MP grease.

SST 09557-22022 (09557-22030)

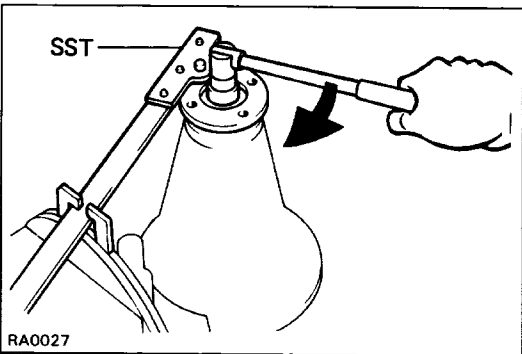

(c) Adjust the drive pinion preload by tightening the companion flange nut.

Using SST to hold the flange, tighten the nut.

SST 09330-00021

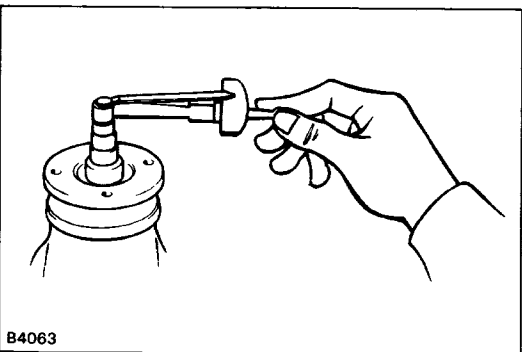

(d) Using a torque meter, measure the preload.

**Preload (starting):**

**New bearing**

1.2 – 1.9 N·m

(12 – 19 kgf·cm, 10.4 – 16.5 in.-lbf)

**Reused bearing**

0.6 – 1.0 N·m

(6 – 10 kgf·cm, 5.2 – 8.7 in.-lbf)

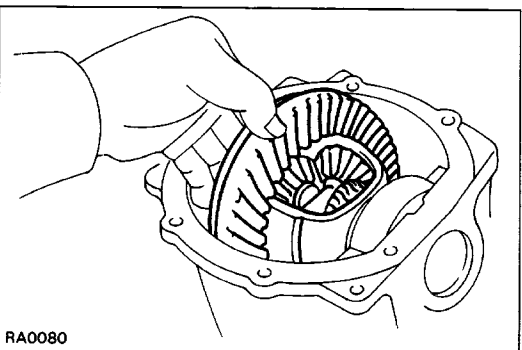

### 2. INSTALL DIFFERENTIAL CASE IN CARRIER

(a) Place the bearing outer races on their respective bearings. Make sure the left and right outer races are not interchanged.

(b) Install the differential case in the carrier.

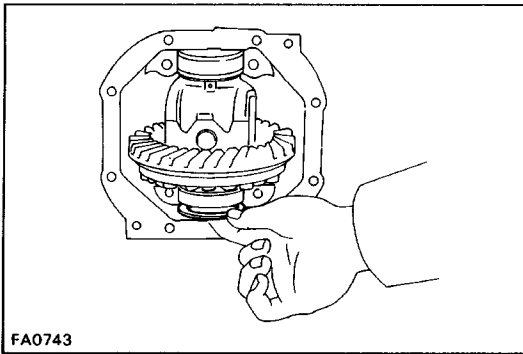

### 3. ADJUST RING GEAR BACKLASH

- (a) Install only the plate washer on the ring gear back side.

HINT: Insure that the ring gear has backlash.

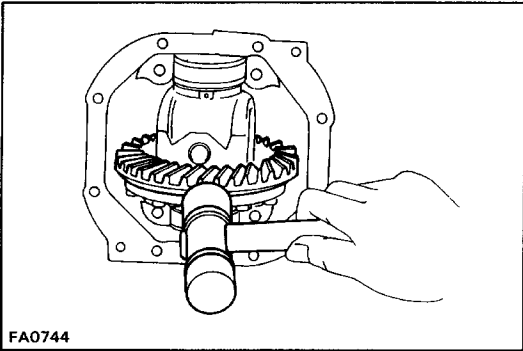

- (b) Snug down the washer and bearing by tapping on the ring gear with a plastic-faced hammer.

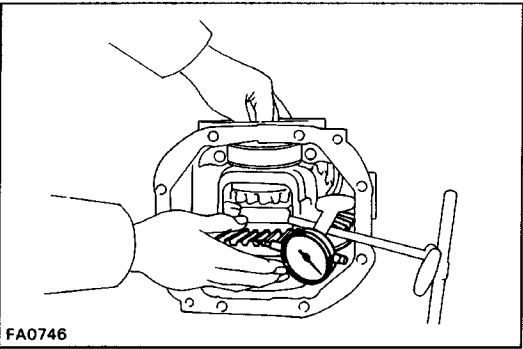

- (c) Hold the side bearing boss on the teeth surface of the ring gear and measure the backlash.

**Backlash (reference): 0.13 mm (0.0051 in.)**

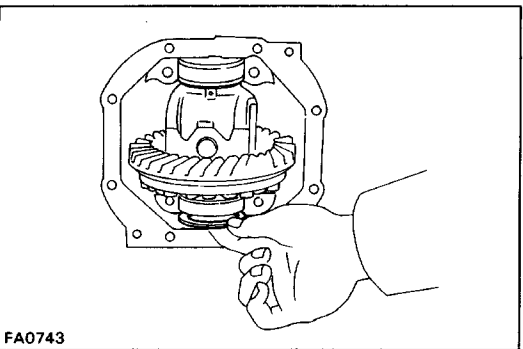

- (d) Select a ring gear back plate washer, using the backlash as reference. (See page [SA-99](#))

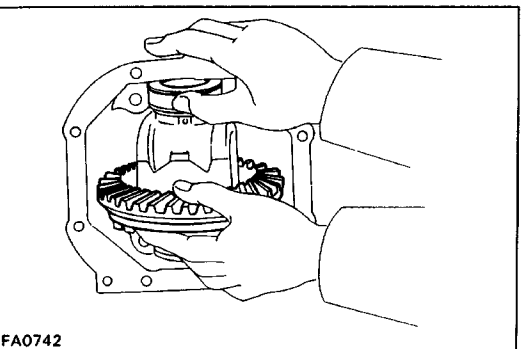

- (e) Select a ring gear teeth side washer with a thickness which eliminates any clearance between the outer race and case.

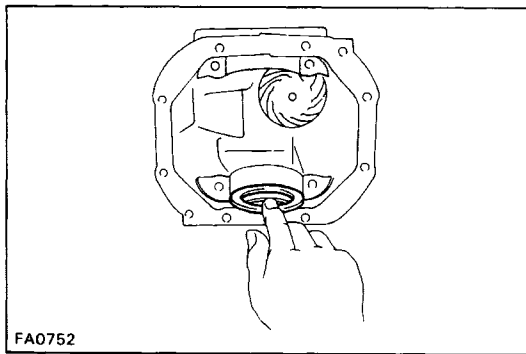

- (f) Remove the plate washers and differential case.  
 (g) Install the plate washer into the lower part of the carrier.

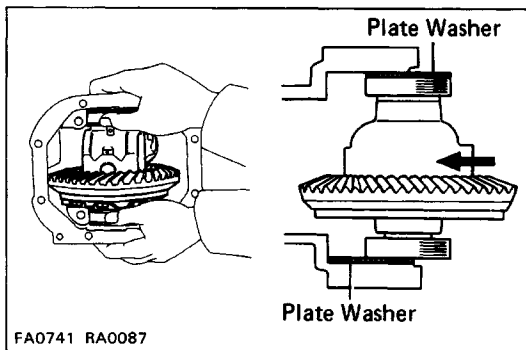

- (h) Place the other plate washer onto the differential case together with the outer race, and install the differential case with the outer race into the carrier.

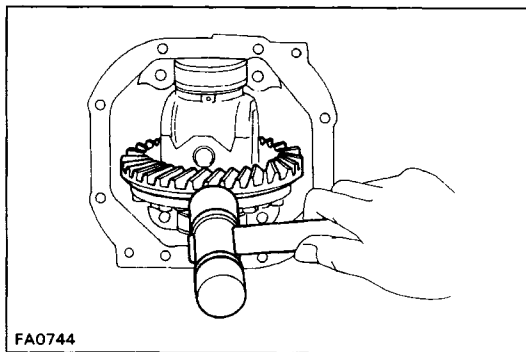

- (i) Using a plastic-faced hammer, snug down the washer and bearing by tapping the ring gear.

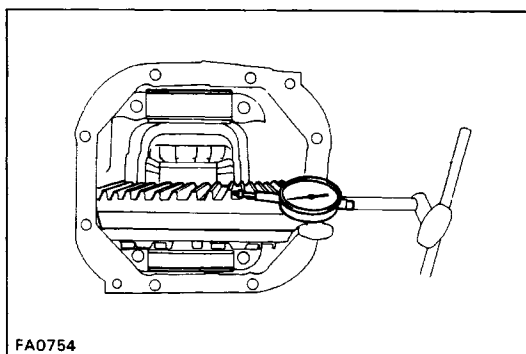

- (j) Using a dial indicator, measure the ring gear backlash.

**Backlash: 0.13 – 0.18 mm (0.0051 – 0.0071 in.)**

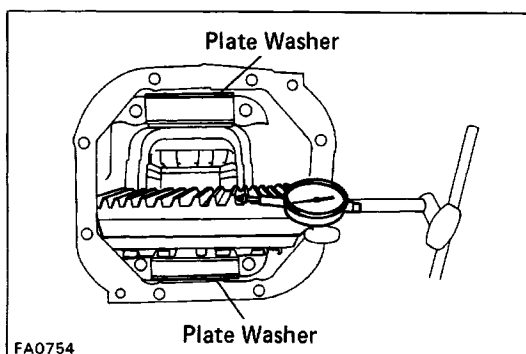

- (k) If not within specification, adjust by either increasing or decreasing the number of washers on both sides by an equal amount.

**HINT:** There should be no clearance between the plate washer and case.

Insure that there is ring gear backlash.

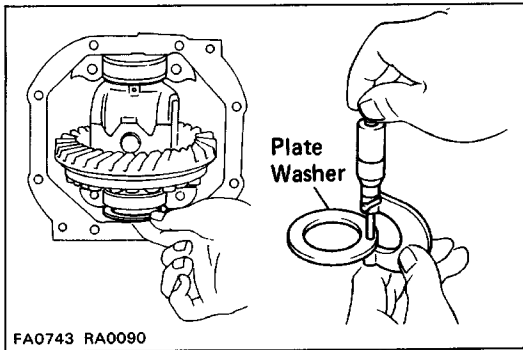

#### 4. ADJUST SIDE BEARING PRELOAD

- (a) Remove the ring gear teeth plate washer and measure the thickness.

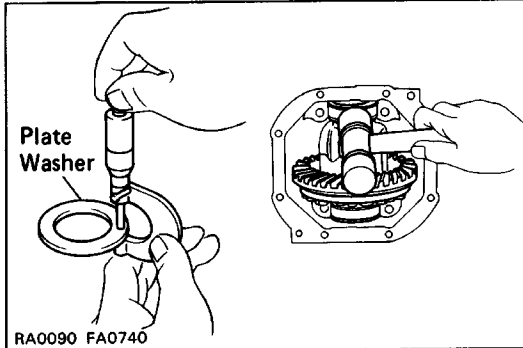

- (b) Using the backlash as a reference, install a new washer of 0.06 – 0.09 mm (0.0024 – 0.0035 in.) thicker than the washer removed.  
HINT: Select a washer which can be pressed in 2/3 of the way with your finger.

- (c) Using a plastic-faced hammer, tap in the side washer.

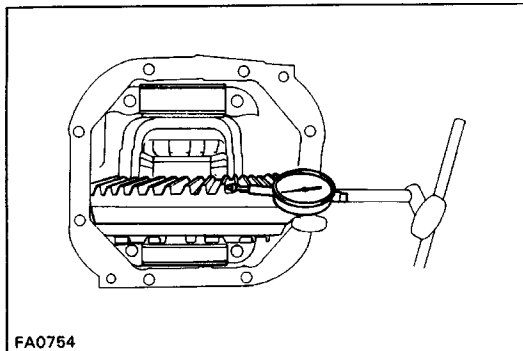

- (d) Recheck the ring gear backlash.

**Backlash: 0.13 – 0.18 mm (0.0051 – 0.0071 in.)**

- (e) If not within standard, adjust by either increasing or decreasing the washers on both sides by an equal amount.

HINT: The backlash will change about 0.02 mm (0.0008 in.) with 0.03 mm (0.0012 in.) alteration of the side washer.

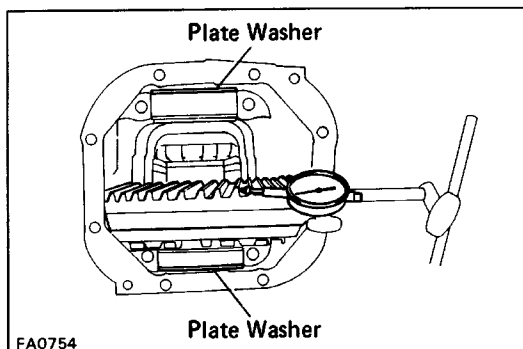

#### Washer thickness

Thickness mm (in.)	
2.57 – 2.59 (0.1012 – 0.1020)	2.93 – 2.95 (0.1154 – 0.1161)
2.60 – 2.62 (0.1024 – 0.1031)	2.96 – 2.98 (0.1165 – 0.1173)
2.63 – 2.65 (0.1035 – 0.1043)	2.99 – 3.01 (0.1177 – 0.1185)
2.66 – 2.68 (0.1047 – 0.1055)	3.02 – 3.04 (0.1189 – 0.1197)
2.69 – 2.71 (0.1059 – 0.1067)	3.05 – 3.07 (0.1201 – 0.1209)
2.72 – 2.74 (0.1071 – 0.1079)	3.08 – 3.10 (0.1213 – 0.1220)
2.75 – 2.77 (0.1083 – 0.1091)	3.11 – 3.13 (0.1224 – 0.1232)
2.78 – 2.80 (0.1094 – 0.1102)	3.14 – 3.16 (0.1236 – 0.1244)
2.81 – 2.83 (0.1106 – 0.1114)	3.17 – 3.19 (0.1248 – 0.1256)
2.84 – 2.86 (0.1118 – 0.1126)	3.20 – 3.22 (0.1260 – 0.1268)
2.87 – 2.89 (0.1130 – 0.1138)	3.23 – 3.25 (0.1272 – 0.1280)
2.90 – 2.92 (0.1142 – 0.1150)	

#### 5. INSTALL SIDE BEARING CAPS

Align the matchmarks on the cap and carrier.

**Torque: 78 N-m (800 kgf-cm, 58 ft-lbf)**

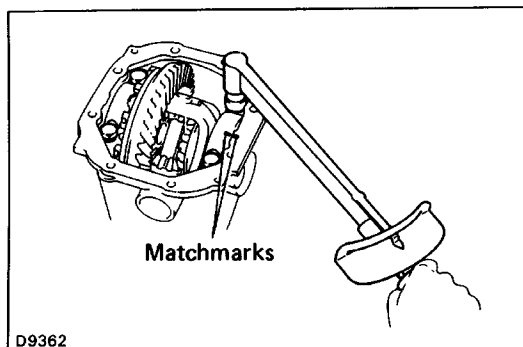

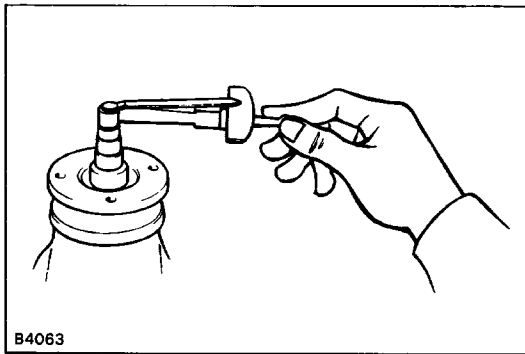

B4063

## 6. MEASURE TOTAL PRELOAD

Using a torque wrench, measure the total preload.

**Total preload (starting):**

**Add drive pinion preload**

**0.4 – 0.6 N-m (4 – 6 kgf-cm, 3.5 – 5.2 in.-lbf)**

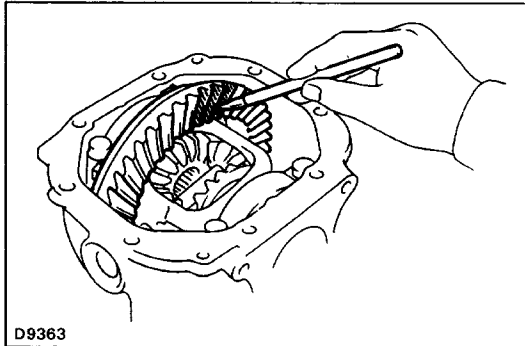

D9363

## 7. INSPECT TOOTH CONTACT BETWEEN RING GEAR AND DRIVE PINION

- Coat 3 or 4 teeth at three different positions on the ring gear with red lead.
- Hold the companion flange firmly and rotate the ring gear in both directions.
- Inspect the tooth pattern.

If the teeth are not contacting properly, use the following chart to select a proper washer for correction.

### Washer thickness

Thickness mm (in.)	
2.24 (0.0882)	2.51 (0.0988)
2.27 (0.0894)	2.54 (0.1000)
2.30 (0.0906)	2.57 (0.1012)
2.33 (0.0917)	2.60 (0.1024)
2.36 (0.0929)	2.63 (0.1035)
2.39 (0.0941)	2.66 (0.1047)
2.42 (0.0953)	2.69 (0.1059)
2.45 (0.0965)	2.72 (0.1071)
2.48 (0.0976)	

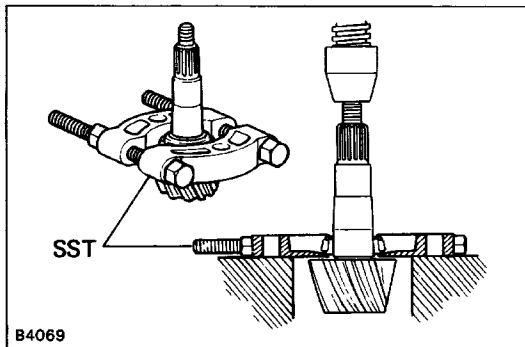

B4069

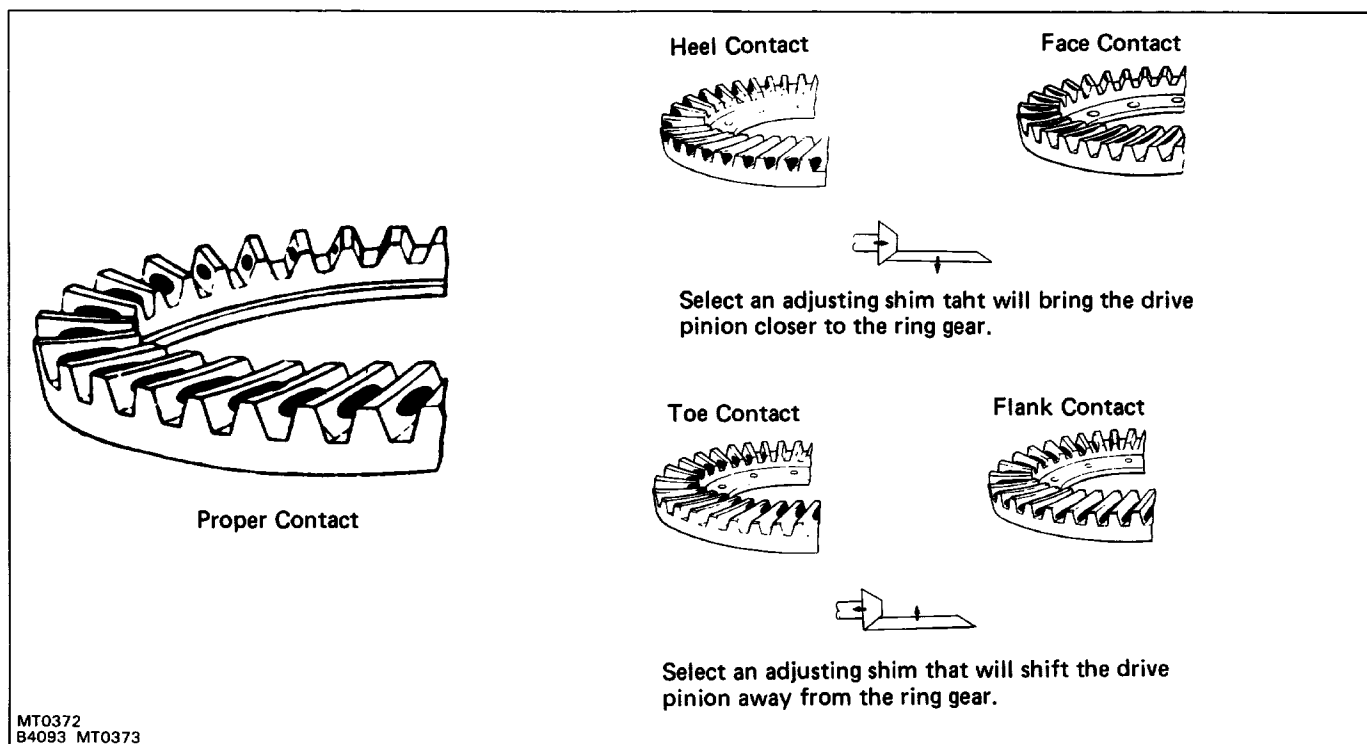

MT0372  
B4093 MT0373

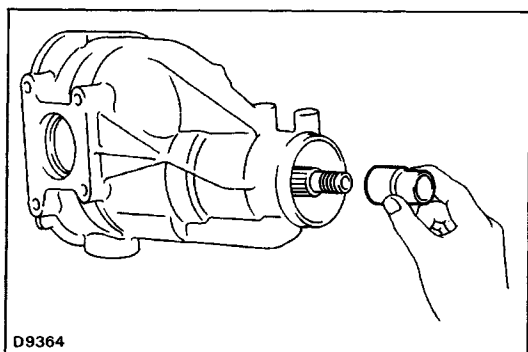

**8. REMOVE COMPANION FLANGE**

(See step 14 on page SA-86)

**9. REMOVE FRONT BEARING**

(See step 16 on page SA-86)

**10. INSTALL NEW BEARING SPACER AND FRONT BEARING**

- Install a new bearing spacer on the drive pinion.
- Install the front bearing on the drive pinion.

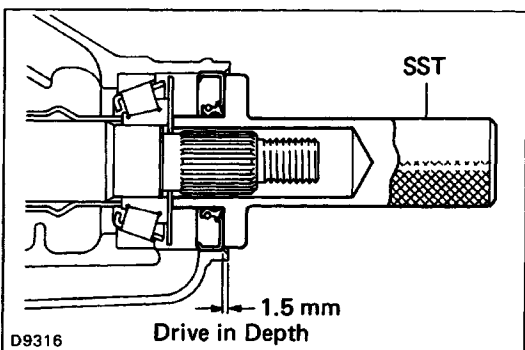
**11. INSTALL OIL SLINGER AND NEW OIL SEAL**

- Install the oil slinger.
- Using SST, drive in a new oil seal.  
SST 09554-30011

**Oil seal drive in depth: 1.5 mm (0.059 in.)**

- Apply MP grease to the oil seal lip.

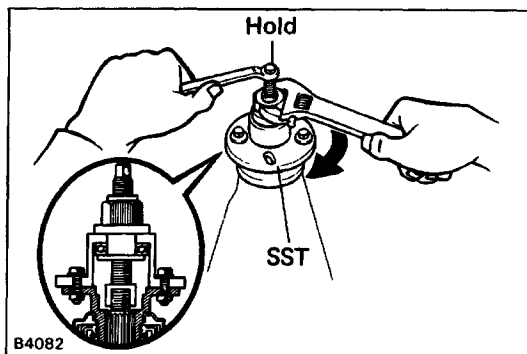
**12. INSTALL COMPANION FLANGE**

- Using SST, install the companion flange on the shaft.  
SST 09557-22022 (09557-22030)

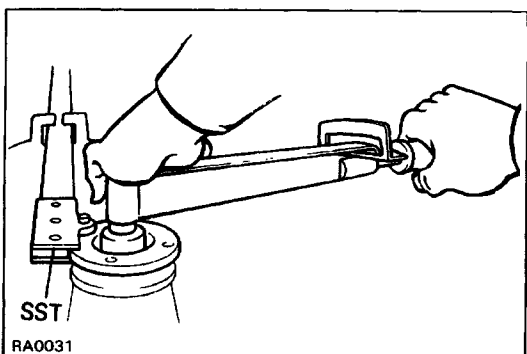

- Coat the threads of a new nut with MP grease.
- Using SST to hold the flange, tighten the nut.

Torque the nut.

SST 09330-00021

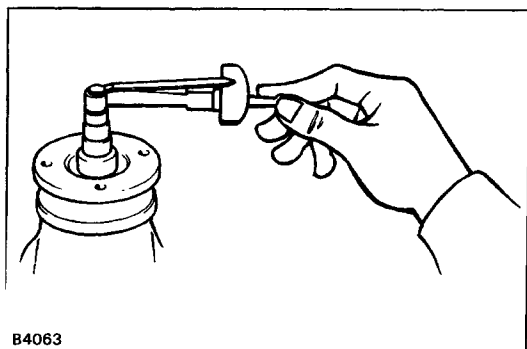
**Torque: 120 N-m (1,225 kgf-cm, 89 ft-lbf)****13. CHECK FRONT BEARING PRELOAD**

Using a torque meter, measure the preload of the backlash between the drive pinion and ring gear.

**Preload (starting):****New bearing**

1.2 – 1.9 N-m

(12 – 19 kgf-cm, 10.4 – 16.5 ft-lbf)

**Reused bearing**

0.6 – 1.0 N-m

(6 – 10 kgf-cm, 5.2 – 8.7 ft-lbf)

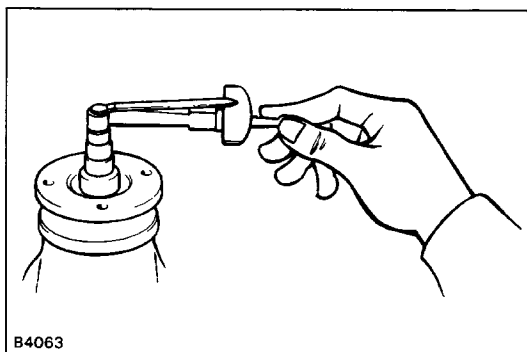

B4063

- (a) If the preload is greater than specification, replace the bearing spacer.
- (b) If the preload is less than specification, retighten the nut 13 N-m (130 kgf-cm, 9 ft-lbf) a little at a time until the specified preload is reached.

**Maximum torque: 223 N-m (2,275 kgf-cm, 165 ft-lbf)**

If the maximum torque is exceeded while retightening the nut, replace the bearing spacer and repeat the preload procedure. Do not back off the pinion nut to reduce the preload.

#### 14. CHECK RUNOUT OF COMPANION FLANGE

Using a dial indicator, measure the vertical and lateral runout of the companion flange.

Maximum vertical runout: 0.10 mm (0.0039 in.)

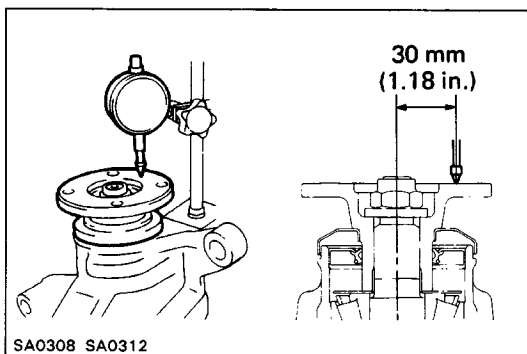

SA0308 SA0312

Maximum lateral runout: 0.10 mm (0.0039 in.)

If the runout is greater than maximum, inspect the bearings.

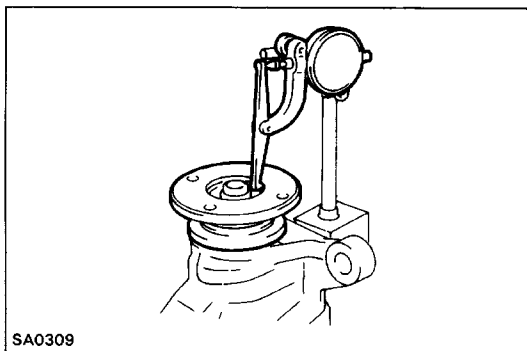

SA0309

#### 15. STAKE DRIVE PINION NUT

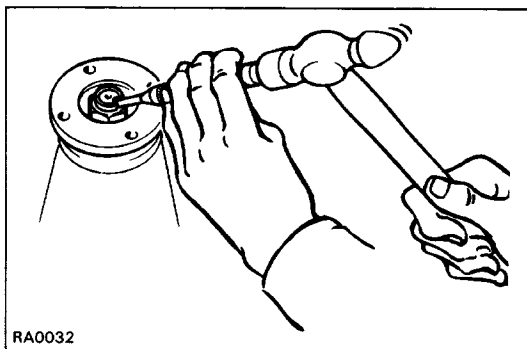

RA0032

#### 16. INSTALL NEW RH SIDE GEAR SHAFT OIL SEAL

- (a) Coat the oil seal lip with MP grease.

- (b) Using SST, drive in the oil seal until it is flush with the carrier end surface.

SST 09550-22011 (09550-00020, 09550-00031)

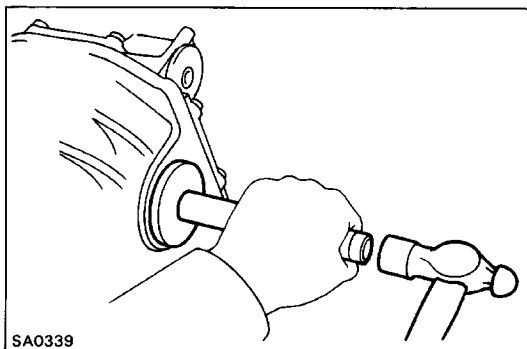

SA0339

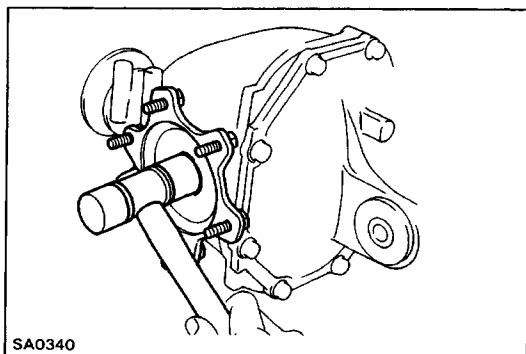
**17. INSTALL RH SIDE GEAR SHAFT**

- (a) Install a new snap ring to the side gear shaft.
- (b) Using a plastic-faced hammer, tap on the side gear shaft to install it.

**18. CHECK INSTALLATION OF SIDE GEAR SHAFT**

- (a) Check that there is 2 – 3 mm (0.08 – 0.12 in.) of play in axial direction.
- (b) Check that the side gear shaft will not come out by trying to pull it completely out by hand.

**19. INSTALL INTERMEDIATE SHAFT**

- (a) Install a new snap ring to the shaft.
- (b) Using a plastic-faced hammer, tap on the shaft to install it.

**20. CHECK INSTALLATION OF INTERMEDIATE SHAFT**

- (a) Check that there is 2 – 3 mm (0.08 – 0.12 in.) of play in axial direction.
- (b) Check that the shaft will not come out by trying to pull it completely out by hand.

**21. INSTALL CLUTCH CASE TO SIDE GEAR SHAFT TUBE**

- (a) Install a new O-ring to the tube.
- (b) Coat the O-ring with MP grease.

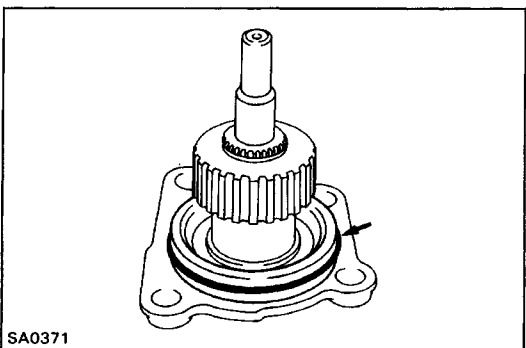
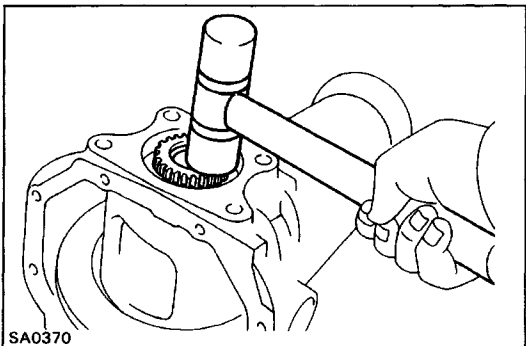

- (c) Install the clutch case to the tube.
- (d) Tighten the two torx bolts.

**Torque: 78 N<sub>z</sub> m 1800 kgf-cm, 58 ft<sub>z</sub> lbf j**

**Torx wrench: E14 (Part No. 09044-00010 or locally manufactured tool)**

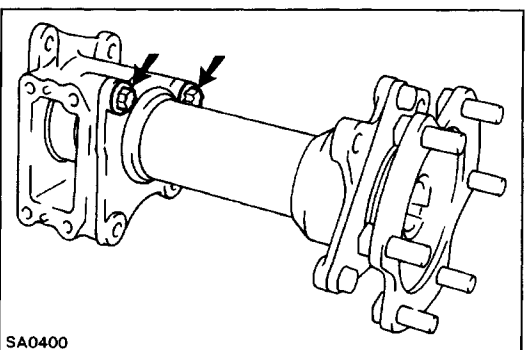
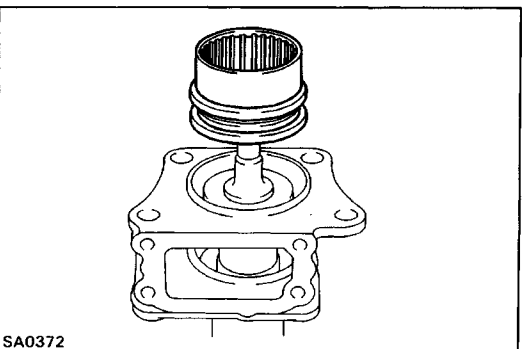
**22. INSTALL CLUTCH SLEEVE**

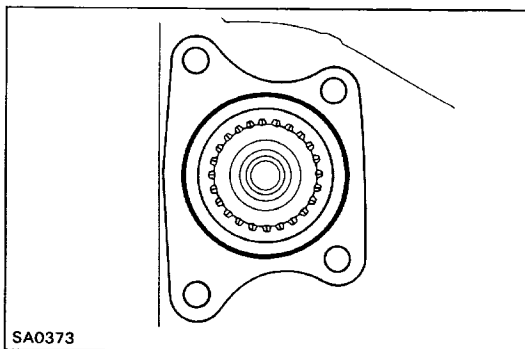

### 23. INSTALL LH SIDE GEAR SHAFT TO DIFFERENTIAL CARRIER

- (a) Remove any packing material and be careful not to get oil on the contacting surfaces of the differential carrier and clutch case.

- (b) Apply seal packing to the differential carrier as shown.

**Seal packing: Part No. 08826-00090, THREE BOND 1281 or equivalent**

**HINT:** Install the side gear shaft within ten minutes after applying seal packing.

- (c) Install LH side gear shaft to the differential carrier. W Tighten the four torx bolts.

**Torque: 78 N-m (800 kgf-cm, 58 ft-lbf)**

**Torx wrench: E14 (Part No. 09044-00010 or locally manufactured tool)**

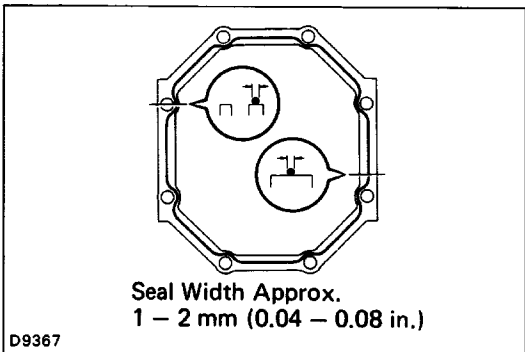
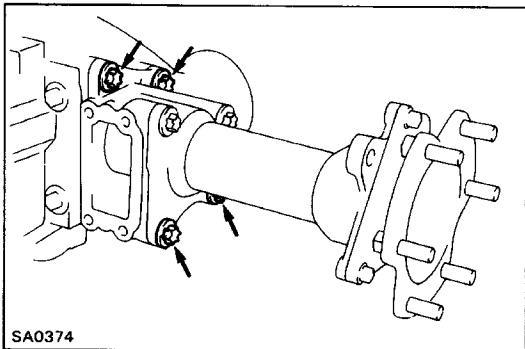

### 24. INSTALL DIFFERENTIAL CARRIER COVER

- (a) Remove any packing material and be careful not to drop oil on the contacting surface of the differential carrier or carrier cover.

- (b) Apply seal packing to the carrier cover.

**Seal packing: Part No. 08826-00090, THREE BOND 1281 or equivalent**

**HINT:** Install the carrier cover within ten minutes after applying seal packing.

- (c) Install and torque the bolts.

**Torque: 47 N-m (475 kgf-cm, 34 ft-lbf)**

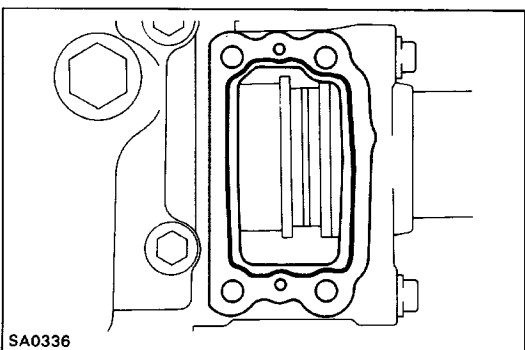
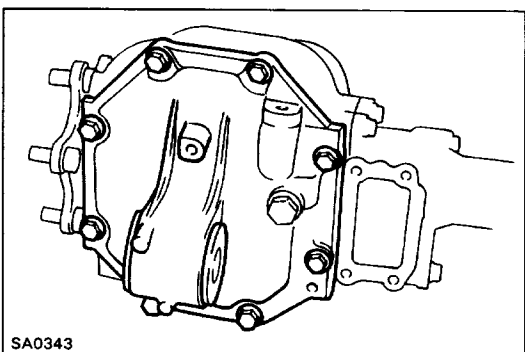

### 25. INSTALL ACTUATOR

- (a) Remove any packing material and be careful not to get oil on the contacting surfaces of the actuator and clutch case.

- (b) Apply seal packing to the clutch case as shown.

**Seal packing: Part No. 08826-00090, THREE BOND 1281 or equivalent**

**HINT:** Install the actuator within ten minutes after applying seal packing.

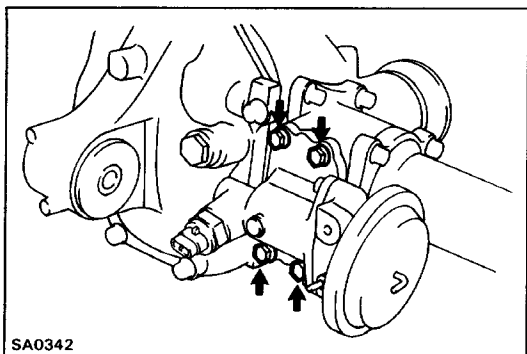

(c) Tighten the four bolts.

**Torque: 21 N-m (210 kgf-cm, 15 ft-lbf)**

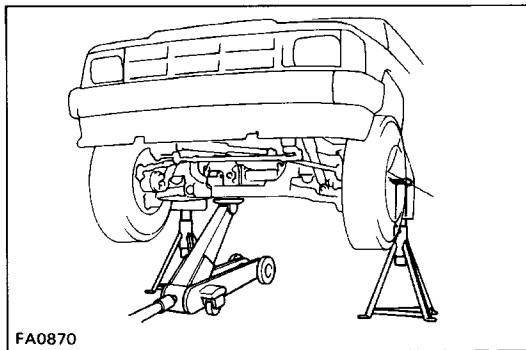

FA0870

## Installation of Front Differential

### 1. INSTALL FRONT DIFFERENTIAL

- (a) Install the front differential to the frame, and support it with a jack.

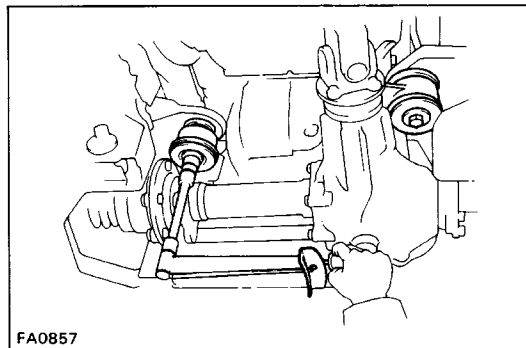

FA0857

- (b) Install and torque the left and right rear mounting bolts.

**Torque: 167 N-m (1,700 kgf-cm, 123 ft-lbf)**

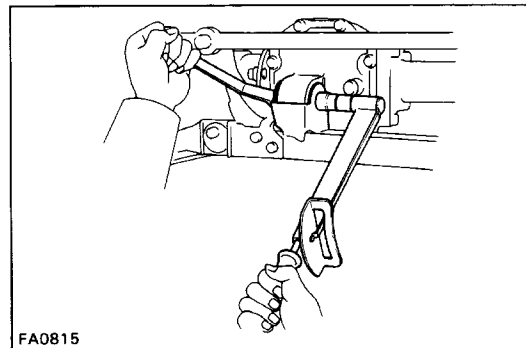

FA0815

### 3. (w/ A.D.D.)

**CONNECT VACUUM HOSES AND 4WD INDICATOR SWITCH CONNECTOR**

### 4. CONNECT DRIVE SHAFTS TO SIDE GEAR SHAFT

Connect the drive shafts to the side gear shaft, and install and torque the nuts while depressing the brake pedal.

**Torque: 83 N-m (845 kgf-cm, 61 ft-lbf)**

### 5. CONNECT PROPELLER SHAFT TO COMPANION FLANGE

- (a) Align the matchmarks on the flanges and connect the flanges with four bolts and nuts.

- (b) Torque the nuts.

**Torque: 74 N-m (750 kgf-cm, 54 ft-lbf)**

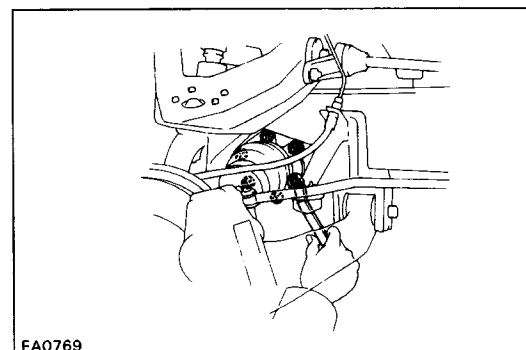

FA0769

### 6. INSTALL DRAIN PLUG AND FILL DIFFERENTIAL WITH GEAR OIL

(w/ A.D.D.)

Oil type: Toyota "GEAR OIL SUPER" oil (Part No.

08885 – 02106) or hypoid gear oil API GL-5

Recommended oil viscosity: SAE 75W-90

Capacity: 1.86 liters (1.97 US qts, 1.64 Imp. qts)

(w/o A.D.D.)

Oil type: Hypoid gear oil API GL-5

Recommended oil viscosity:

Above – 18°C (0°F) SAE 90

Below – 18°C (0°F) SAE 80W or 80W-90

Capacity: 1.6 liters (1.7 US qts, 1.4 Imp. qts)

# A.D.D. Control System COMPONENTS

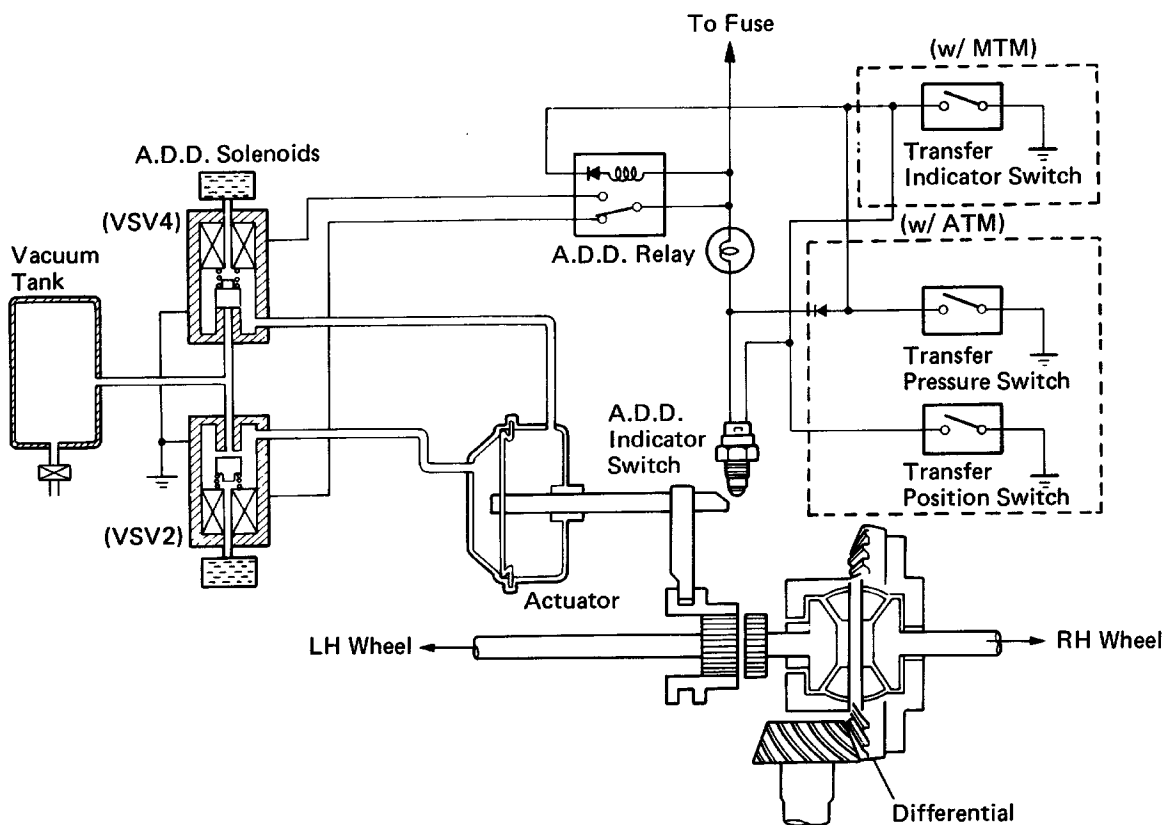
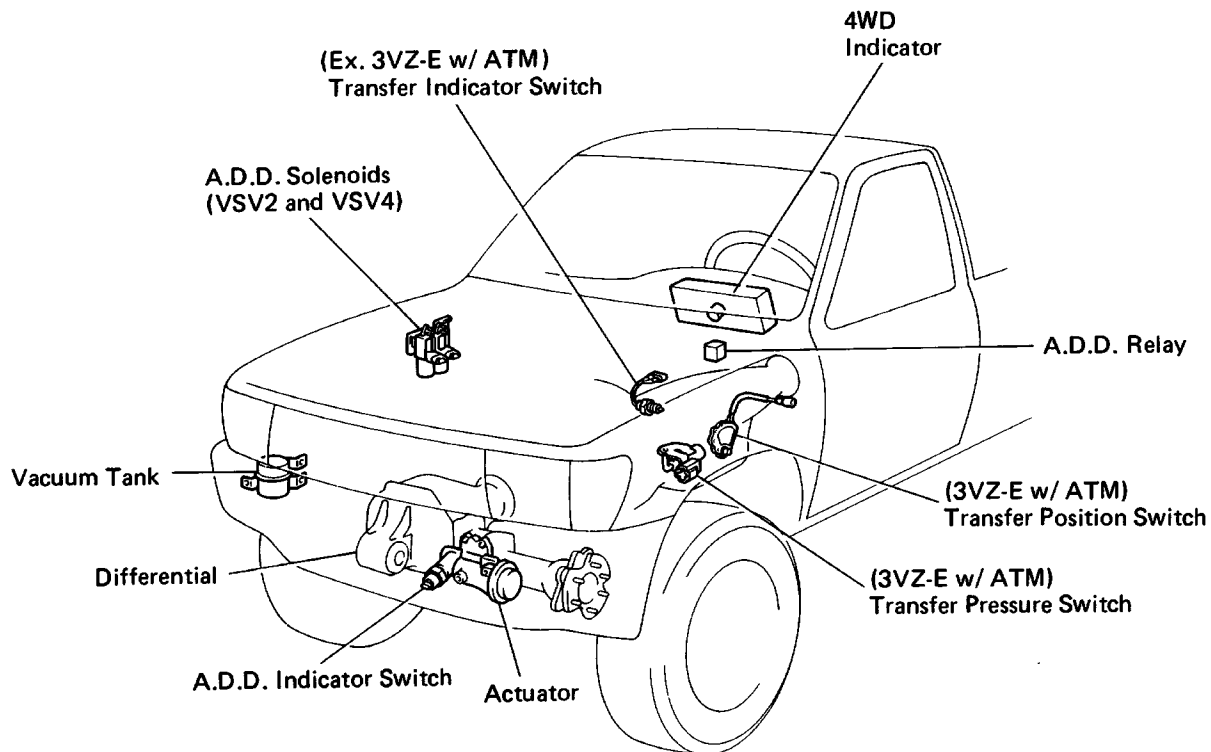

# ELECTRICAL CIRCUIT

[Ex. 3VZ-E w/ ATM]

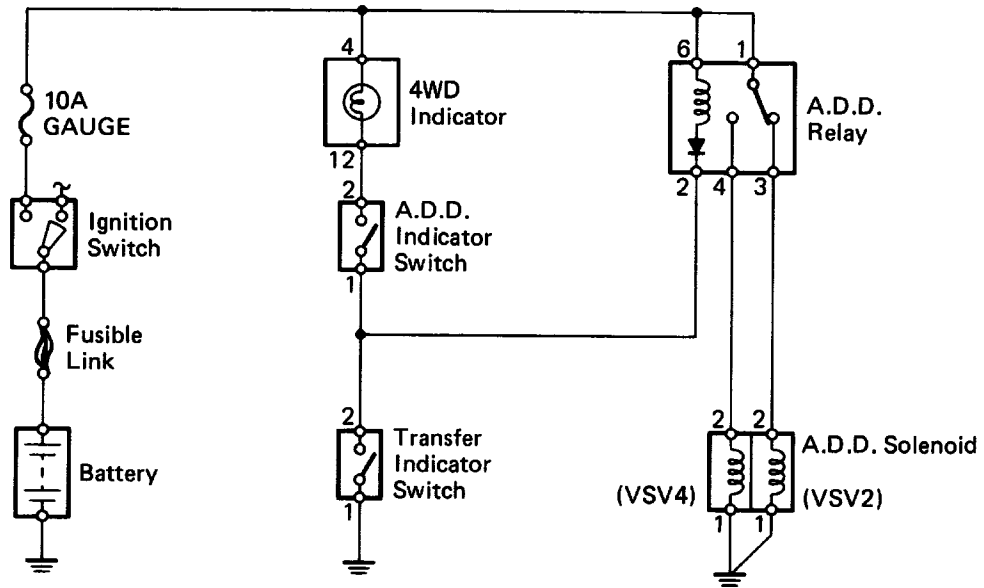

[3VZ-E w/ ATM]

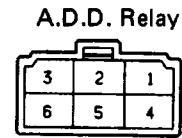
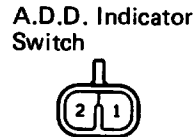
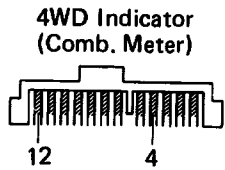
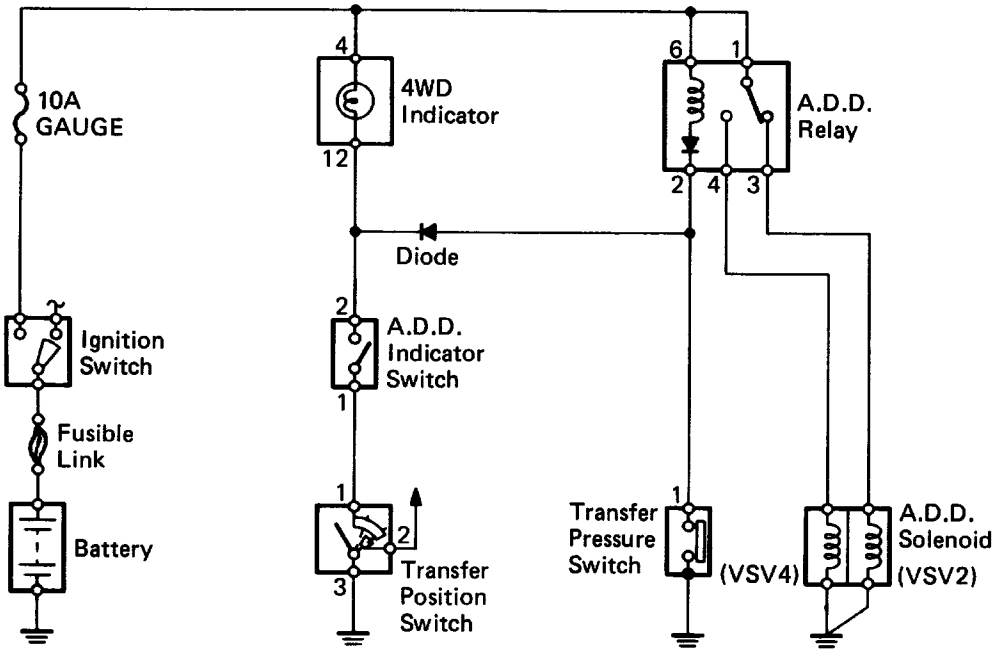

A.D.D. Solenoids

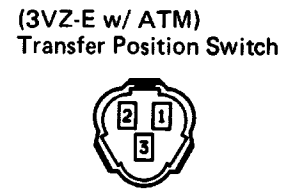
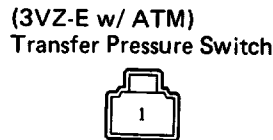

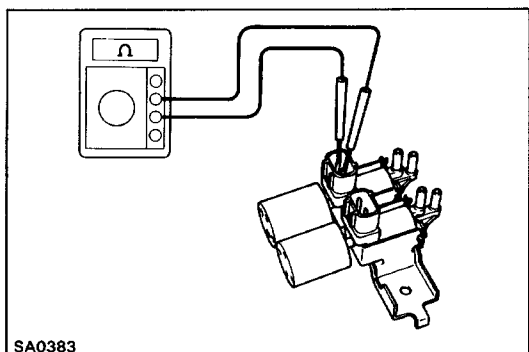

**INSPECTION OF COMPONENTS****1. INSPECT A.D.****D. SOLENOIDS**

(a) Measure the resistance of the solenoids.

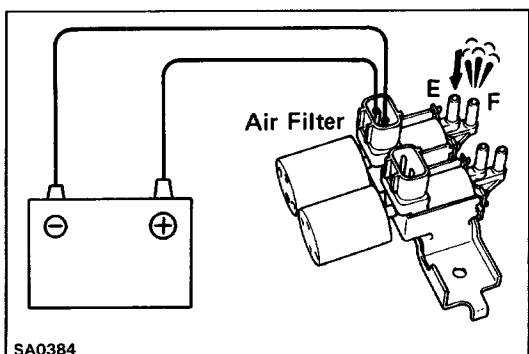
**Resistance: 37 – 44/**

(b) Apply the battery voltage to the solenoid.

Check that air flows from port E to port F.

Check that air does not flow from port E to the air filter.

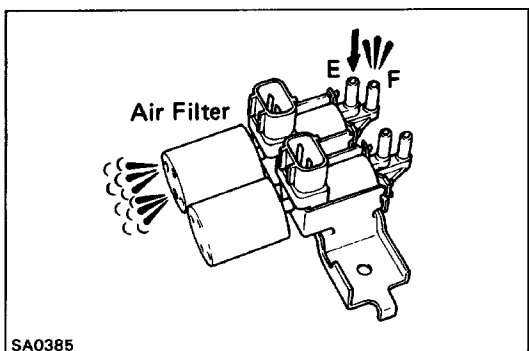

(c) Disconnect the battery voltage from the solenoid.

Check that air flows from port E to the air filter.

Check that air does not flow from port E to port F.

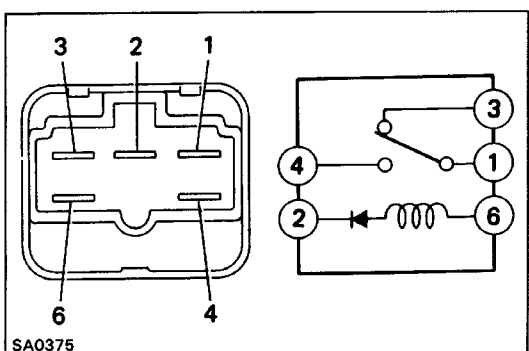
**2. INSPECT A.D.D. RELAY****(Continuity)**

Terminal	1	2	3	4	6
Condition					
Constant		○	←	○	○
Apply battery voltage to terminals 6 and 2.	○	○		○	

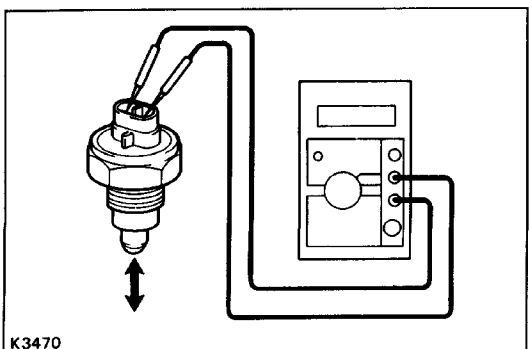
**3. INSPECT A.D.****D. INDICATOR SWITCH**

(a) Check that there is continuity between terminals when the switch is pushed (differential connected position).

(b) Check that there is no continuity when the switch is free (differential disconnected position).

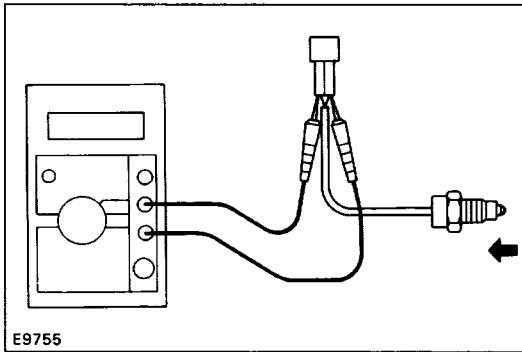

#### 4. (Ex. 3VZ-E w/ATM )

##### INSPECT TRANSFER INDICATOR SWITCH

- Check that there is continuity between terminals when the switch is pushed (transfer 4WD position).
- Check that there is no continuity between terminals when the switch is free position (transfer H 2 position).

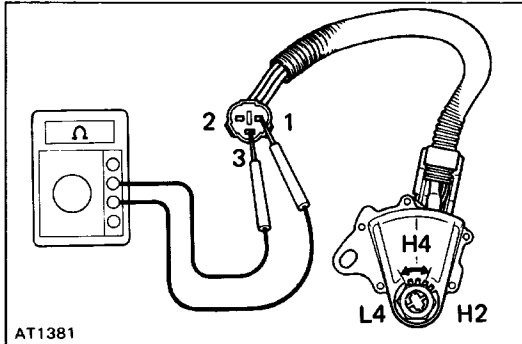

#### 5. (3VZ-E w/ATM)

##### INSPECT TRANSFER POSITION SWITCH

Check that there is continuity between each terminal.

Terminal	1	2	3
Transfer position			
H4	○	○	○
L4	○	○	○
H2			

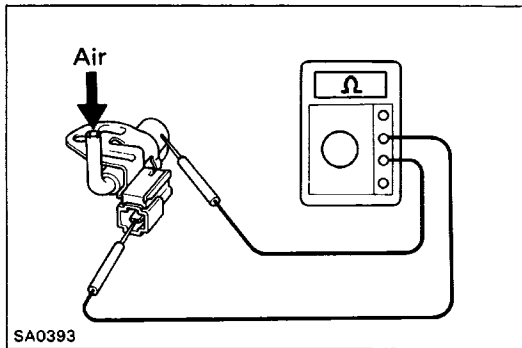

#### 6. (3VZ-E w/ATM)

##### INSPECT TRANSFER PRESSURE SWITCH

While blowing compressed air (3.0 kg/cm<sup>2</sup>, 43 psi or 294 kPa) into the switch, check the continuity between the terminal and switch body.

**Resistance: 0 Ω**

# FRONT SUSPENSION COMPONENTS

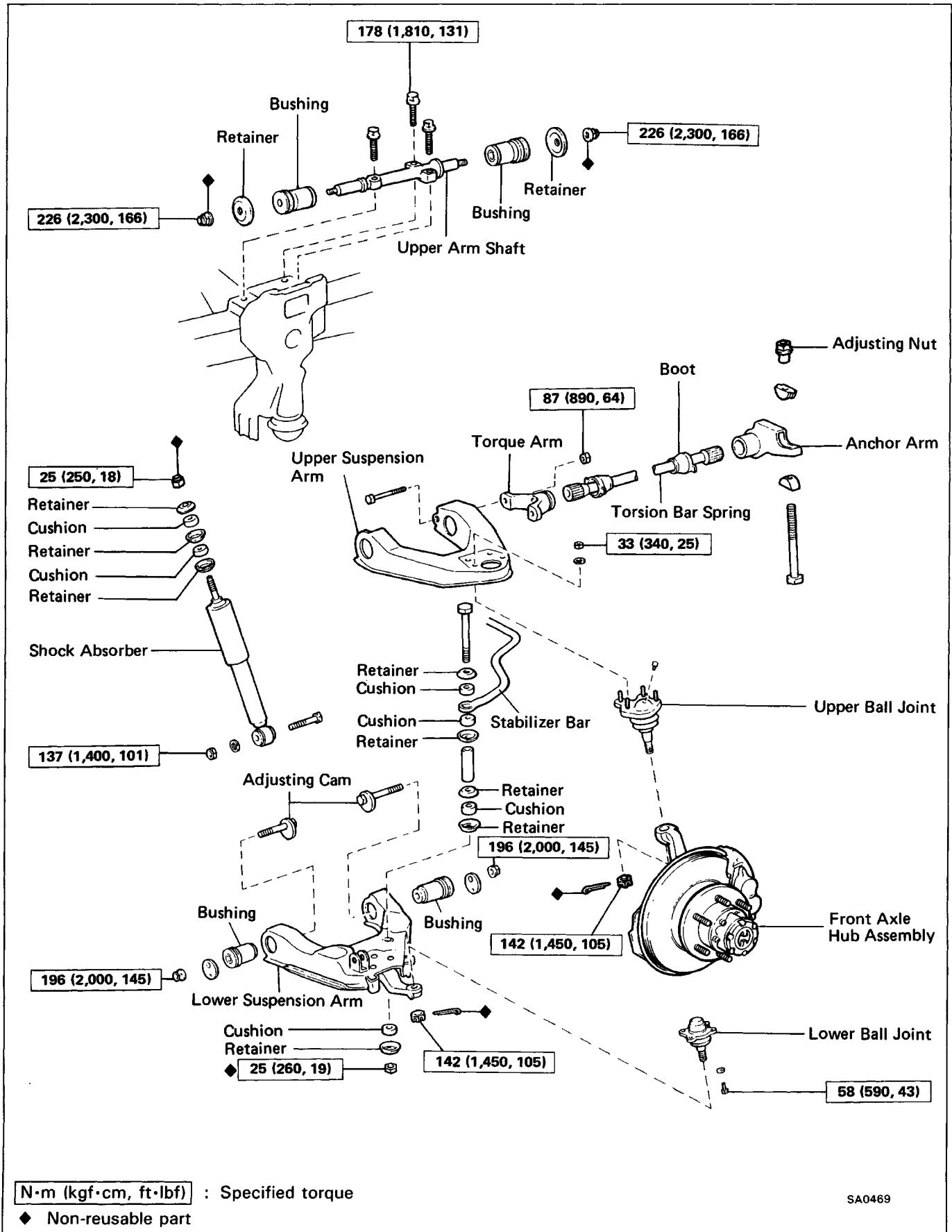

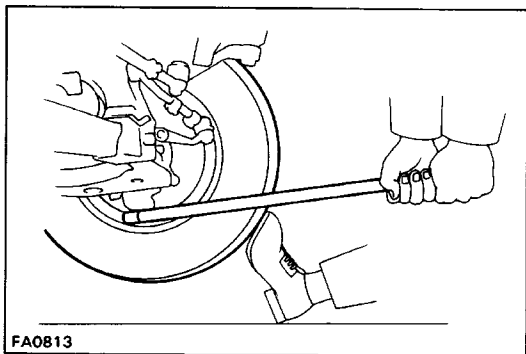

FA0813

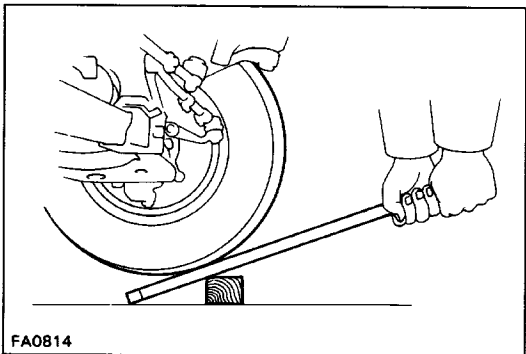

FA0814

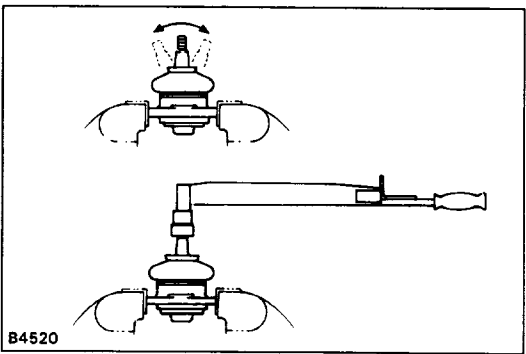

B4520

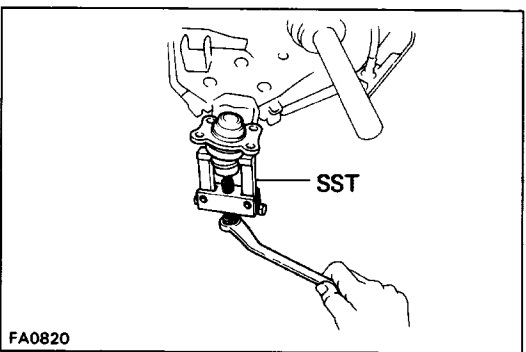

FA0820

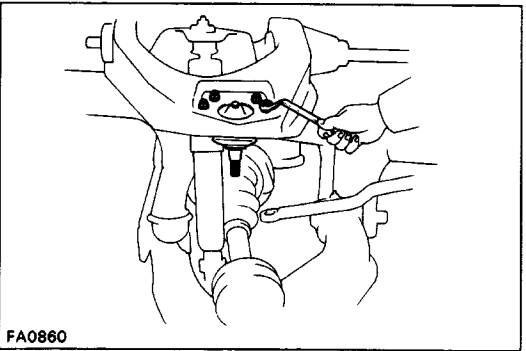

FA0860

## Ball Joint

(See page [SA-111](#))

### INSPECTION OF BALL JOINTS

#### 1. INSPECT LOWER BALL JOINT FOR EXCESSIVE LOOSENESS

- Jack up the front of the vehicle and support it with stands.
- Make sure the front wheels are in a straight forward position, and depress the brake pedal.
- Move the lower suspension arm up and down and check that the lower ball joint has no excessive play.

**Maximum vertical play: 2.3 mm (0.091 in.)**

#### 2. INSPECT UPPER BALL JOINT FOR EXCESSIVE LOOSENESS

Move the vehicle up and down and check that the upper ball joint has no excessive play.

**Maximum vertical play: 0 mm (0 in.)**

#### 3. INSPECT BALL JOINT FOR ROTATION CONDITION

- Remove the ball joints.
- As shown in the figure, flip the ball joint stud back and forth 5 times before installing the nut.
- Using a torque gauge, turn the nut continuously one turn every 2 – 4 seconds and take the torque reading on the 5th turn.

**Torque (turning):**

**Lower ball joint**

**3.0 – 5.9 N·m**

**(30 – 60 kgf·cm, 26 – 52 in.-lbf)**

### REMOVAL OF BALL JOINTS

#### 1. REMOVE STEERING KNUCKLE

(See page [SA-41](#))

#### 2. REMOVE LOWER BALL JOINT FROM LOWER SUSPENSION ARM

- Remove the cotter pin and nut.
- Using SST, remove the lower ball joint from the lower suspension arm.

SST 09628-62011

#### 3. REMOVE UPPER BALL JOINT FROM UPPER SUSPENSION ARM

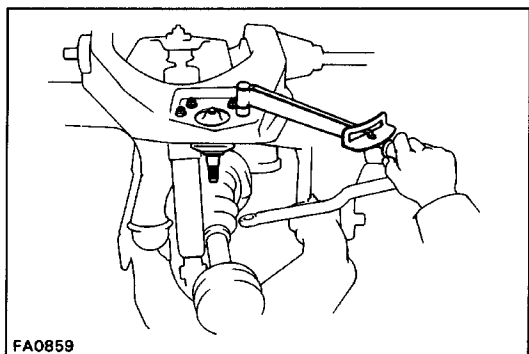

## INSTALLATION OF BALL JOINTS

### 1. INSTALL UPPER BALL JOINT TO UPPER SUSPENSION ARM

Torque: 33 N-m (340 kgf-cm, 25 ft-lbf)

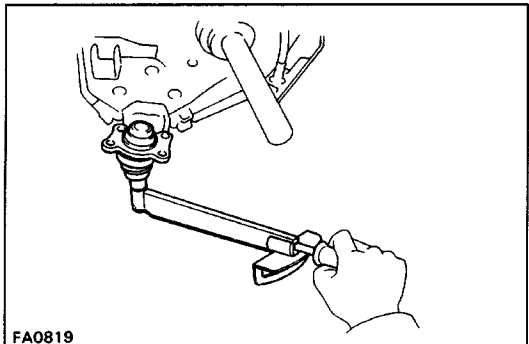

### 2. INSTALL LOWER BALL JOINT TO LOWER SUSPENSION ARM

(a) Install the lower ball joint to the lower suspension arm.

(b) Torque the nut and install a new cotter pin.  
Torque: 142 N-m (1,450 kgf-cm, 105 ft-lbf )

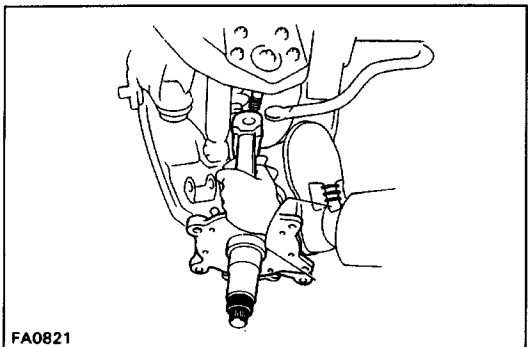

### 3. INSTALL STEERING KNUCKLE

(See page [SA-43](#))

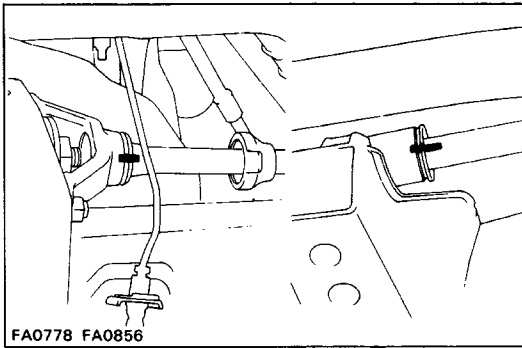

## Torsion Bar Spring

(See page SA-111)

### REMOVAL OF TORSION BAR SPRING

#### 1. PLACE MATCHMARKS ON TORSION BAR SPRING, ANCHOR ARM AND TORQUE ARM

Remove the boots and place matchmarks on the torsion bar spring, anchor arm and torque arm.

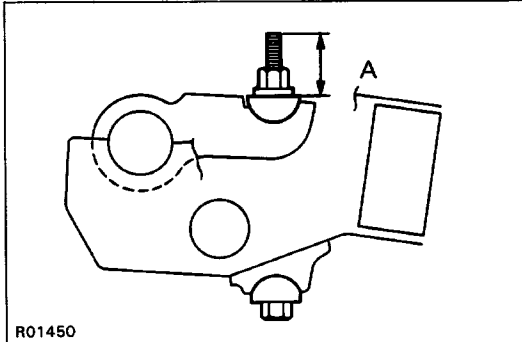

#### 2. MEASURE PROTRUDING BOLT END "A", AS SHOWN

HINT: Use this measurement for reference when adjusting the chassis ground clearance.

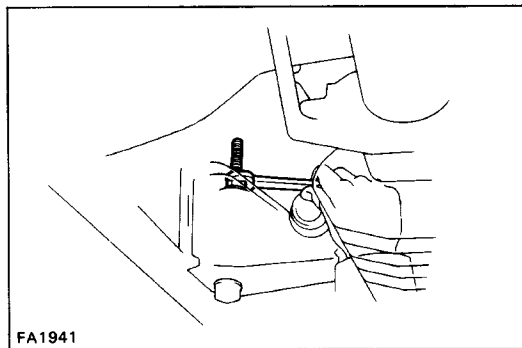

#### 3. LOOSEN ADJUSTING NUT AND REMOVE ANCHOR ARM AND TORSION BAR SPRING

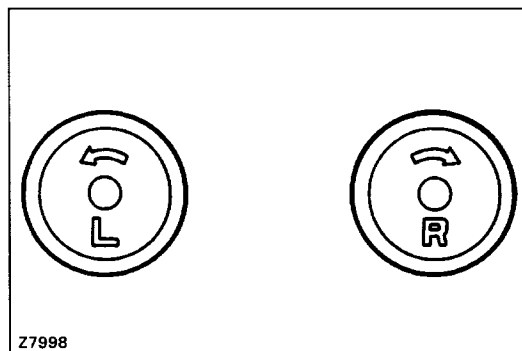

### INSTALLATION OF TORSION BAR SPRING

HINT: There are left and right indication marks on the rear end of the torsion bar spring. Be careful not to interchange them.

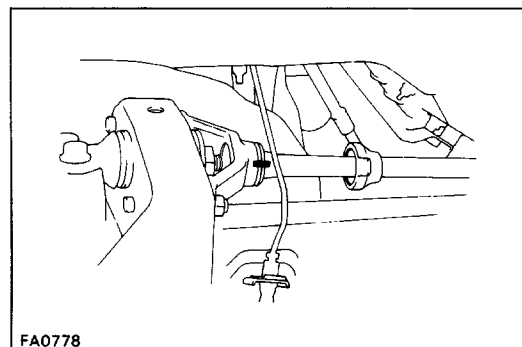

#### 1. INSTALL TORSION BAR SPRING AND ANCHOR ARM If Reusing Torsion Bar Spring

- Apply a light coat of molybdenum disulphide lithium base grease to the spline of the torsion bar spring.
- Align the matchmarks and install the torsion bar spring to the torque arm.
- Align the matchmarks and install the anchor arm to the torsion bar spring.

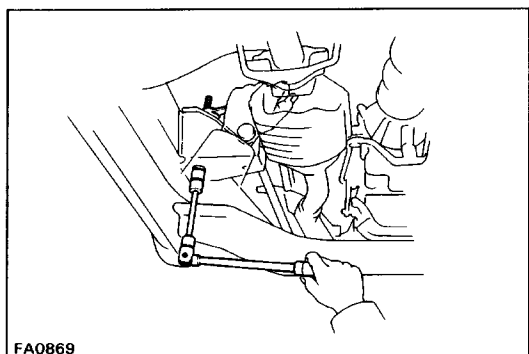

- (d) Tighten the adjusting nut so that the bolt protrusion is equal to that before removal.

### If Using a New Torsion Bar Spring

- Remove the wheel.
- Install the two boots to the torsion bar spring.
- Apply a light coat of the molybdenum disulphide lithium base grease to the spline of the torsion bar spring.
- Temporarily install the anchor arm to the small end of the torsion bar spring and place the matchmarks on the torsion bar spring and anchor arm.

#### HINT:

- There is one spline on the torsion bar spring that is larger than the others. Install the torsion bar spring into the anchor arm by slowly turning the anchor arm until you feel the large spline enter the matching point in the anchor arm.
- Place matchmarks on the torsion bar spring and anchor arm on the bottom of each.

- Remove the anchor arm from the torsion bar spring.
- Install the torsion bar spring into the torque arm.

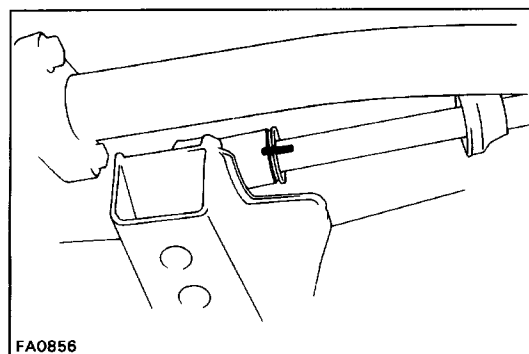

HINT: There is one spline on the torsion bar spring that is larger than the others. Install the torsion bar spring into the torque arm by slowly turning the torsion bar spring until you feel the large spline enter the matching point in the torque arm.

- Align the matchmarks and install the anchor arm to the torsion bar spring.
- Torque the adjusting nut.

**Nut tightening limit: A = 70 mm (2.76 in.)**

- Temporarily install the lock nut.
- Install the wheel and remove the stands, bounce the vehicle to settle the suspension.
  - Adjust the chassis ground clearance by turning the adjusting nut.

**Chassis ground clearance: See pages A-25, 26**

## 2. ASSEMBLE BOOTS

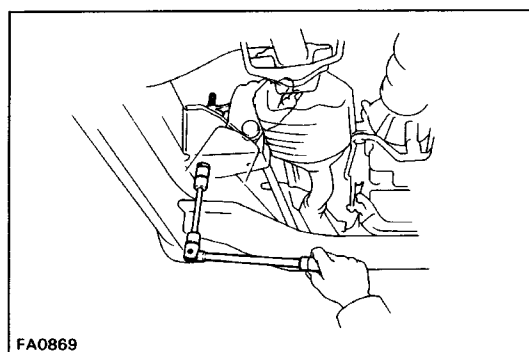

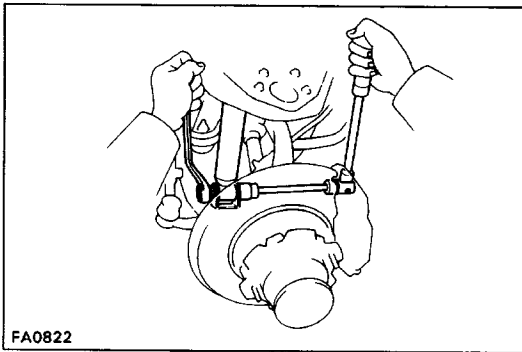

FA0822

## Lower Suspension Arm and Shock Absorber

(See page SA-111)

### REMOVAL OF LOWER SUSPENSION ARM AND SHOCK ABSORBER

#### 1. REMOVE SHOCK ABSORBER

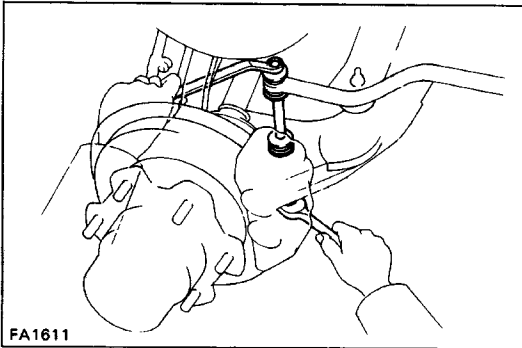

FA1611

#### 2. DISCONNECT STABILIZER BAR FROM LOWER SUSPENSION ARM

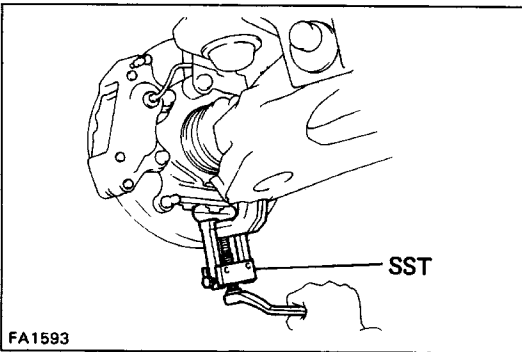

FA1593

#### 3. DISCONNECT LOWER SUSPENSION ARM FROM LOWER BALL JOINT

- (a) Remove the cotter pin and loosen the nut.
- (b) Using SST, disconnect the lower suspension arm from the lower ball joint.  
SST 09628-62011

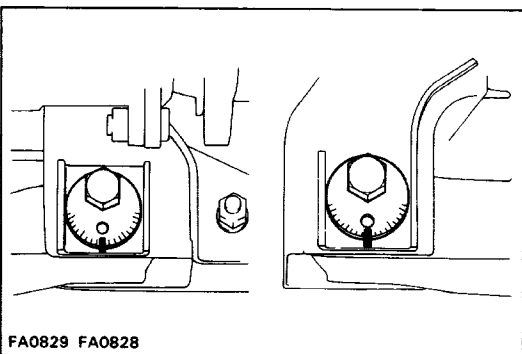

FA0829 FA0828

#### 4. REMOVE LOWER SUSPENSION ARM

- (a) Place matchmarks on the front and rear adjusting cams.

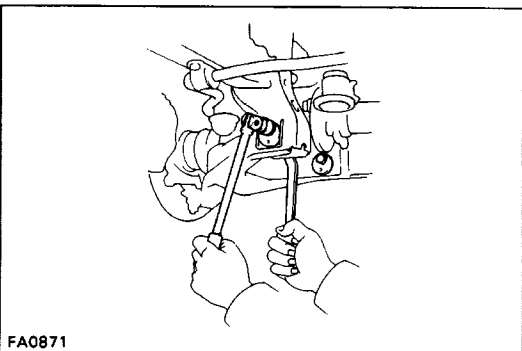

FA0871

- (b) Remove the nuts and adjusting cams, and remove the lower suspension arm.



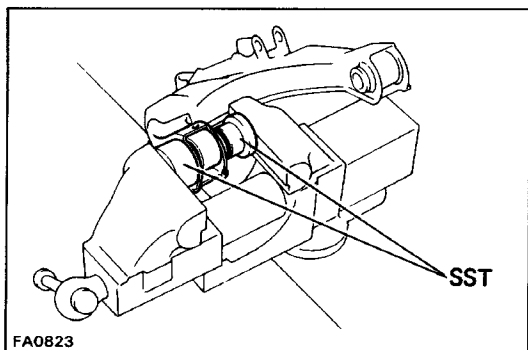

## PLACEMENT OF LOWER SUSPENSION ARM BUSHING

### 1. REMOVE FRONT AND REAR BUSHINGS

Using SST, press out the bushings from the lower suspension arm.

SST 09726-27011 (09726-02050, 09726-02060)

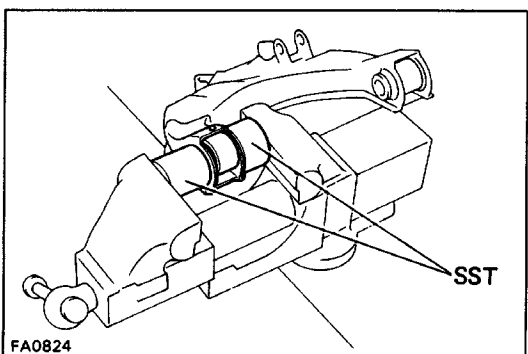

### 2. INSTALL FRONT AND REAR BUSHINGS

Using SST, press in new bushings to the lower suspension arm.

SST 09726-27011 (09726-02040, 09726-02060)

HINT: Do not apply grease or oil to the bushing.

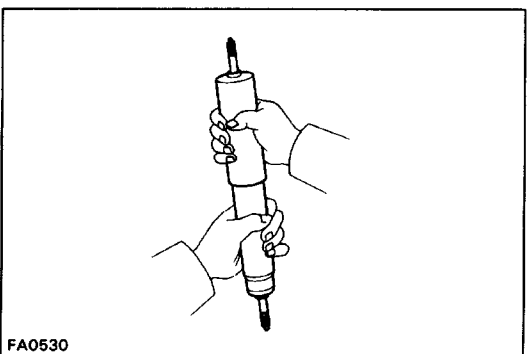

## INSPECTION OF SHOCK ABSORBER

### INSPECT OPERATION OF SHOCK ABSORBER

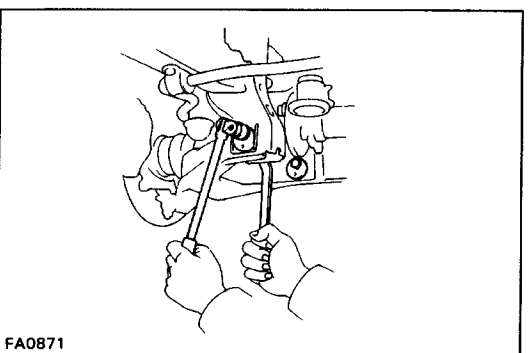

## INSTALLATION OF LOWER SUSPENSION ARM AND SHOCK ABSORBER

### 1. INSTALL LOWER SUSPENSION ARM

- Install the lower suspension arm to the frame with adjusting cams.
- Temporarily install the two nuts to the front and rear adjusting cams.

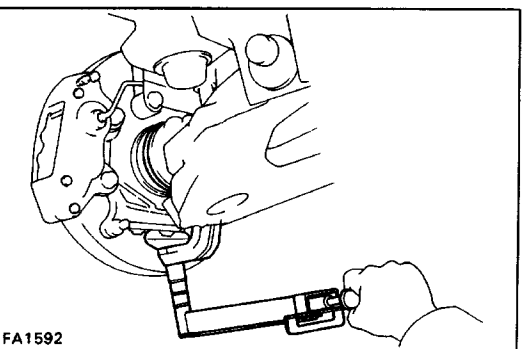

### 2. CONNECT LOWER SUSPENSION ARM TO LOWER BALL JOINT

- Connect the lower suspension arm to the lower ball joint and torque the nut.

**Torque: 142 N-m (1,450 kgf -cm, 105 ft-lbf)**

- Install a new cotter pin.

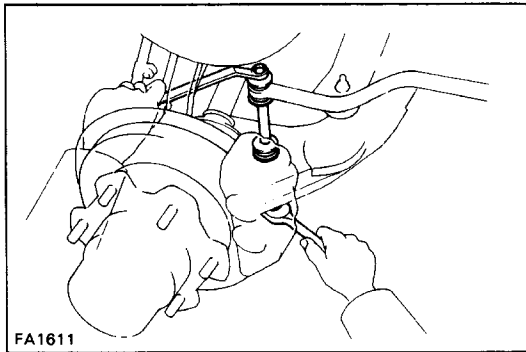

FA1611

### 3. CONNECT STABILIZER BAR TO LOWER SUSPENSION ARM

Jack up the stabilizer bar and install the cushions, retainers, collar and bolt, and install and torque the nut.

**Torque: 25 N-m (250 kgf-cm, 19 ft-lbf)**

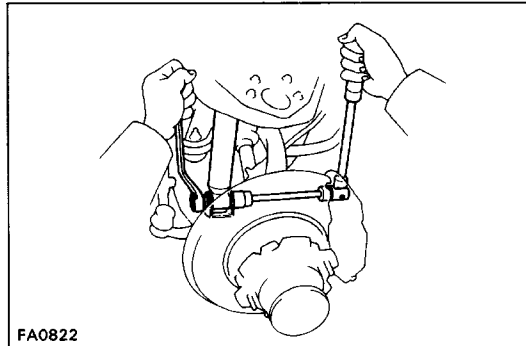

FA0822

### 4. INSTALL SHOCK ABSORBER TO LOWER SUSPENSION ARM

Install the shock absorber to lower suspension arm bracket.

**Torque: 137 N-m (1,400 kgf-cm, 101 ft-lbf)**

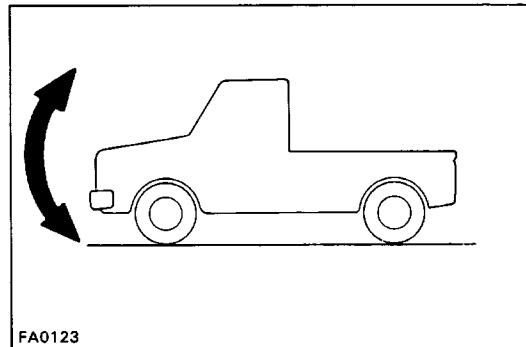

FA0123

### 5. TORQUE ADJUSTING CAM NUTS

- (a) Install the wheel, and remove the stands and bounce the vehicle up and down to stabilize the suspension.

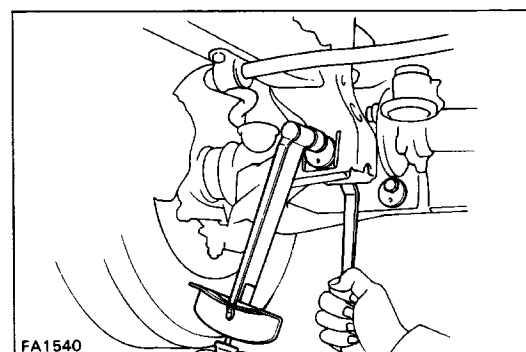

FA1540

- (b) Align the matchmarks and torque the nuts.

**Torque: 196 N-m (2,000 kgf-cm, 145 ft-lbf)**

### 6. CHECK FRONT WHEEL ALIGNMENT

(See page [SA-6](#))

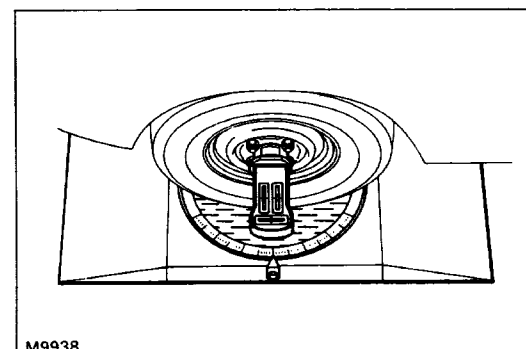

M9938

## Upper Suspension Arm

(See page SA-111)

### REMOVAL OF UPPER SUSPENSION ARM

#### 1. REMOVE TORSION BAR SPRING

(See page SA-114)

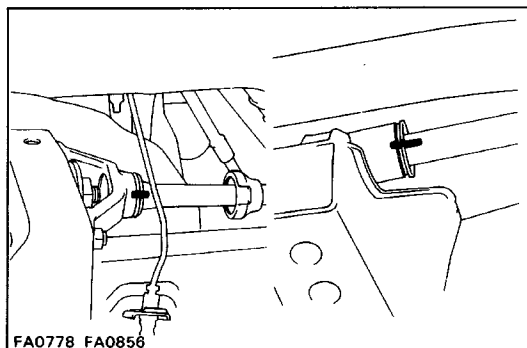

#### 2. DISCONNECT UPPER SUSPENSION ARM FROM UPPER BALL JOINT

Remove the cotter pin and nut, and using SST disconnect the upper ball joint from the steering knuckle.

SST 09628-62011

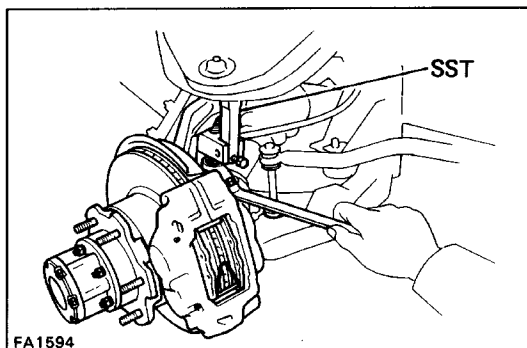

#### 3. DISCONNECT SHOCK ABSORBER FROM FRAME

Remove the nut, cushion and retainer, and disconnect the shock absorber from the frame.

HINT: Do not disconnect the shock absorber from the lower suspension arm.

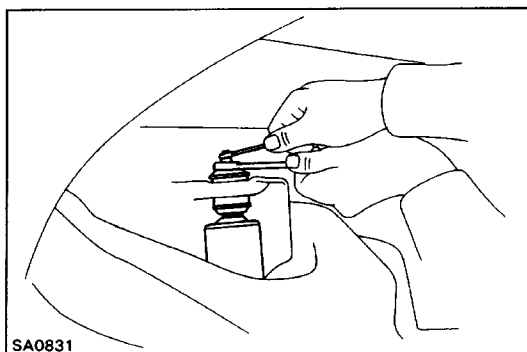

#### 4. REMOVE UPPER SUSPENSION ARM

(a) Disconnect the intermediate shaft from the steering gear housing.

(b) Remove the three bolts, and remove the upper suspension arm from the frame.

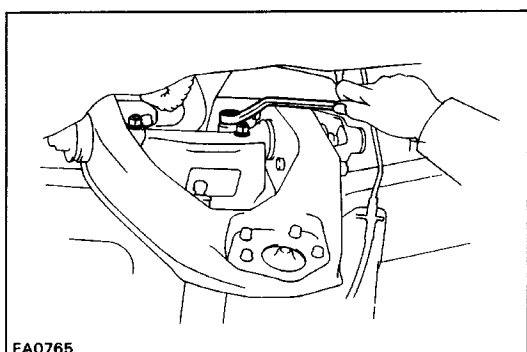

### REPLACEMENT OF UPPER ARM BUSHING

#### 1. REMOVE TORQUE ARM

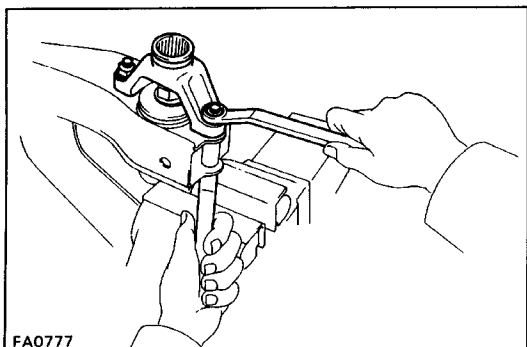

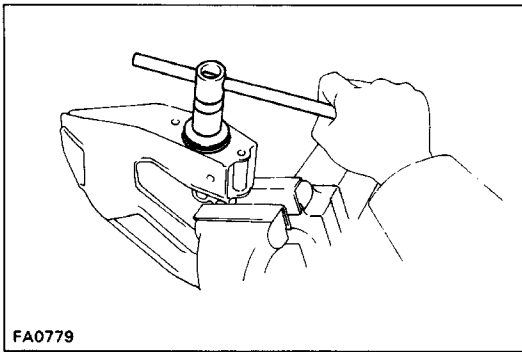

## 2. REMOVE FRONT BUSHING

- (a) Using a chisel and hammer, loosen the staked part of the nut.
- (b) Remove the nut.

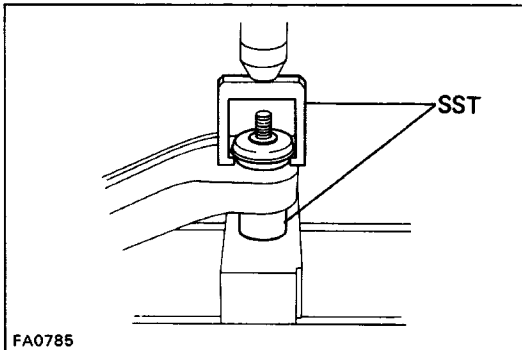

- (c) Using SST, push out the front bushing.  
SST 09710-26010 (09710-05040, 09710-05050)

## 3. REMOVE UPPER ARM SHAFT

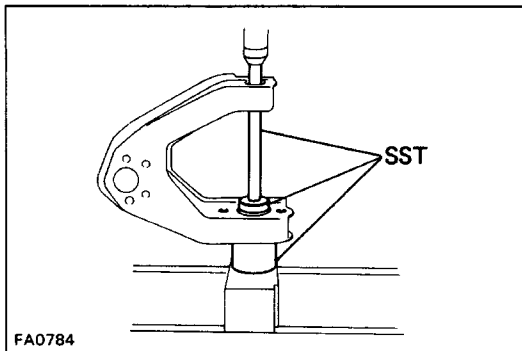

## 4. REMOVE REAR BUSHING

Using SST, push out the rear bushing.

SST 09710-26010

(09710-05020, 09710-05030, 09710-05080)

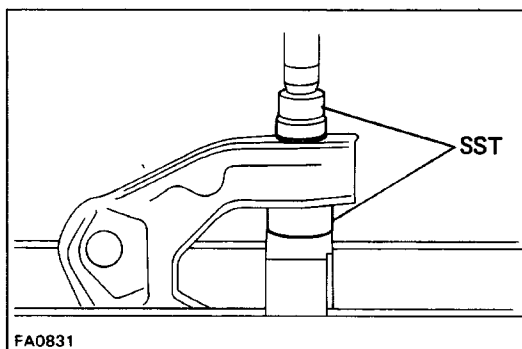

## 5. INSTALL REAR BUSHING

- (a) Using SST, push in a new bushing.  
SST 09710-26010 (09710-05060, 09710-05080)  
HINT: Do not apply grease or oil to the bushing.
- (b) Install the upper arm shaft.

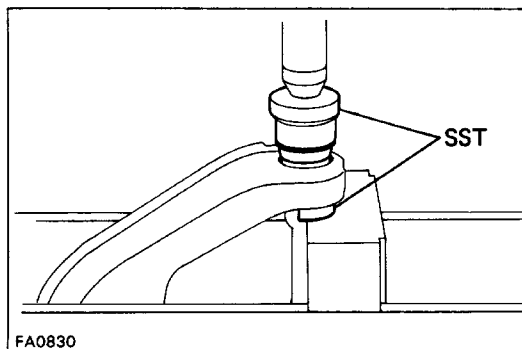

## 6. INSTALL FRONT BUSHING

Using SST, push in a new front bushing.

SST 09710-26010 (09710-05060, 09710-05080)

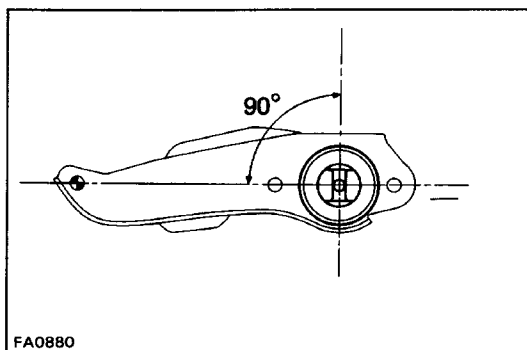

## 7. TORQUE UPPER ARM SHAFT

- (a) Install the retainers and new nuts.

HINT: Position the upper arm shaft so that the frame installation surface is level with the arm.

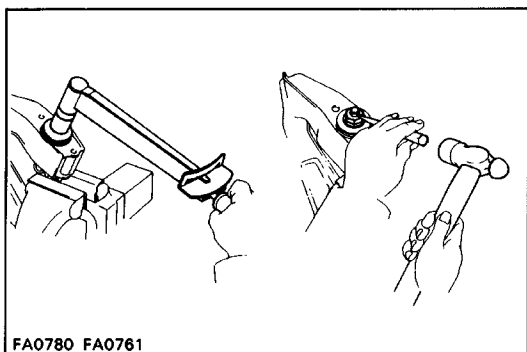

- (b) Torque the shaft nuts.

**Torque: 226 N-m (2,300 kgf-cm, 166 ft-lbf)**

- (c) Stake the nuts with a hammer and chisel.

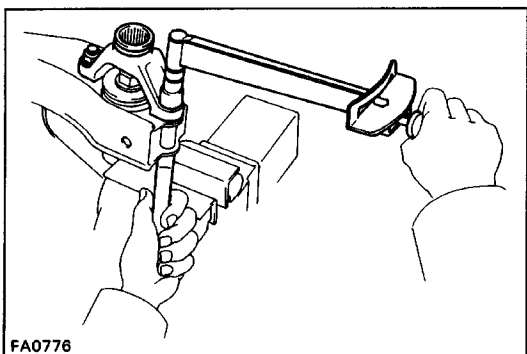

## 8. INSTALL TORQUE ARM TO UPPER ARM

**Torque: 87 N-m (890 kgf-cm, 64 ft-lbf)**

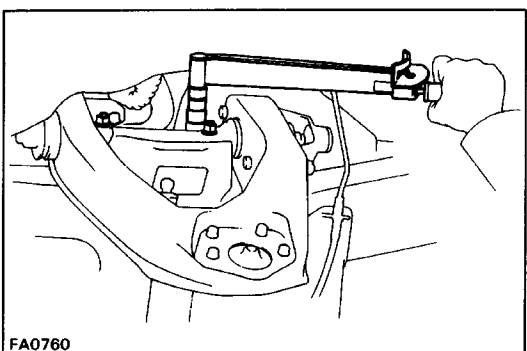

## INSTALLATION OF UPPER SUSPENSION ARM

### 1. INSTALL UPPER SUSPENSION ARM TO FRAME

- (a) Install the lower suspension arm to the frame and torque the mounting bolts.

**Torque: 178 N-m (1,810 kgf-cm, 131 ft-lbf)**

- (b) Connect the intermediate shaft to the steering gear housing.

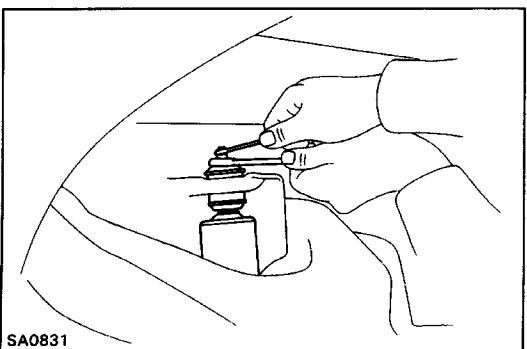

### 2. CONNECT SHOCK ABSORBER TO FRAME

Connect the shock absorber to frame with cushion and retainer and install and torque a new nut as shown in the figure.

**Torque: 25 N-m (250 kgf-cm, 18 ft-lbf)**

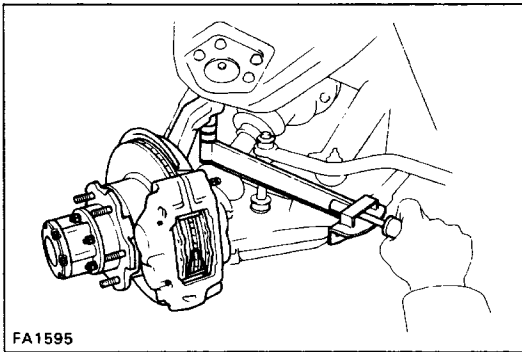

### 3. CONNECT UPPER SUSPENSION ARM TO UPPER BALL JOINT

- (a) Connect the upper ball joint to the steering knuckle and install and torque the nut.

**Torque: 142 N-m (1,450 kgf-cm, 105 ft-lbf)**

- (b) Install a new cotter pin.

### 4. INSTALL TORSION BAR SPRING

(See page SA-114)

### 5. CHECK FRONT WHEEL ALIGNMENT

(See page SA-6)

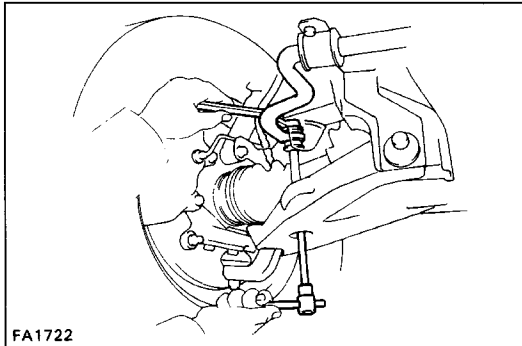

## Stabilizer Bar

(See page SA-111)

### REMOVAL OF STABILIZER BAR

#### REMOVE STABILIZER BAR

- (a) Remove the nut, cushions and retainers holding both sides of the stabilizer bar from the lower suspension arms, and disconnect the stabilizer bar.
- (b) Remove both stabilizer bar brackets and cushions, and remove the stabilizer bar.

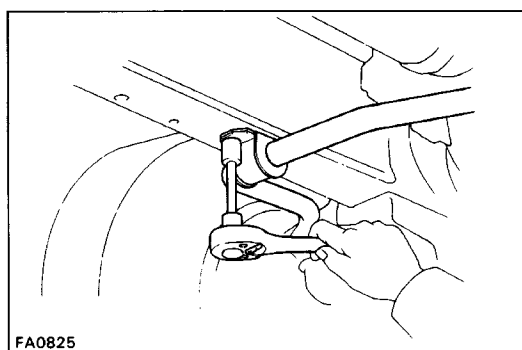
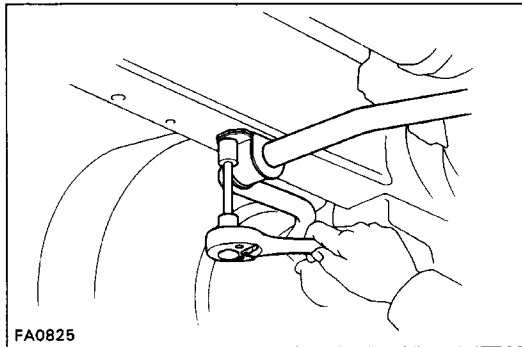

### INSTALLATION OF STABILIZER BAR

#### 1. PLACE STABILIZER BAR TO FRAME

Place the stabilizer bar in position and install the both stabilizer bar cushion and brackets to the frame. Temporarily install the bolts.

#### 2. CONNECT STABILIZER BAR TO LOWER SUSPENSION ARMS

Connect the stabilizer bar on both sides to the lower arms with bolts, cushion, retainers and a new nut as shown.

Torque the nut.

**Torque: 25 N-m (260 kgf-cm, 19 ft-lbf)**

#### 3. TORQUE BRACKET SET BOLTS TO FRAME

**Torque: 29 N-m (300 kgf-cm, 22 ft-lbf)**

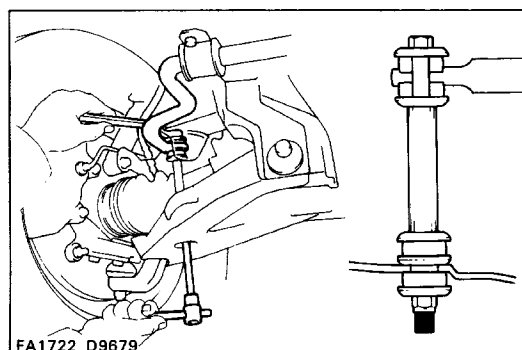

# REAR AXLE SHAFT (Single Tire) COMPONENTS

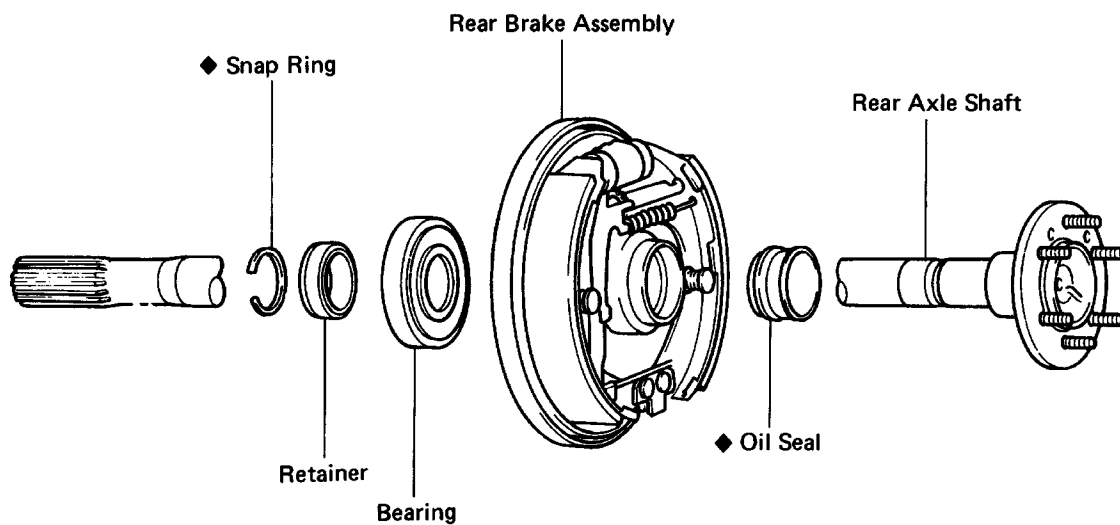
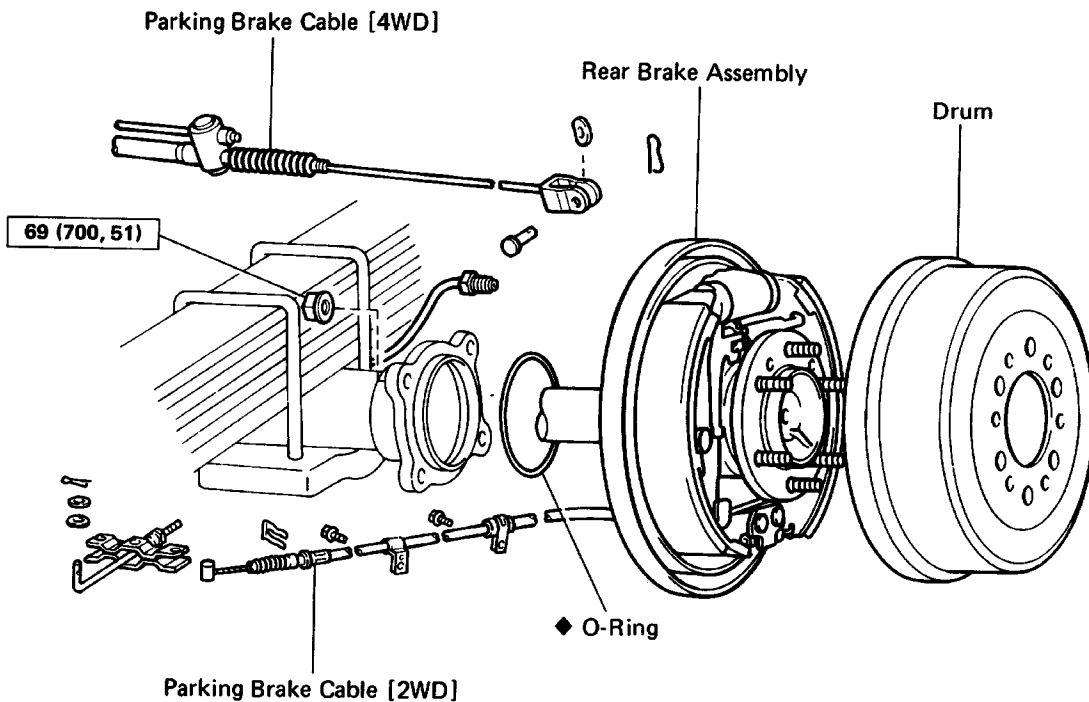

N·m (kgf·cm, ft·lbf) : Specified torque

◆ Non-reusable part

SA0387  
SA0388

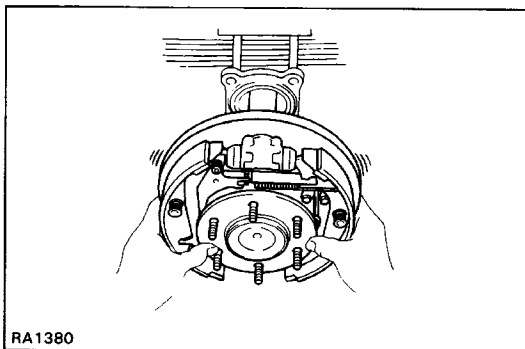

## REMOVAL OF REAR AXLE SHAFT

1. REMOVE WHEEL AND BRAKE DRUM
2. DISCONNECT BRAKE TUBE AND PARKING BRAKE CABLE
3. REMOVE FOUR BACKING PLATE MOUNTING NUTS
4. REMOVE REAR AXLE SHAFT FROM REAR AXLE HOUSING
5. REMOVE SNAP RING
6. REMOVE REAR AXLE SHAFT FROM BACKING PLATE

(a) Attach SST to the backing plate.

SST 09521-25011

(b) Press out the rear axle shaft from the backing plate.

**NOTICE:** When pulling out the rear axle, be careful not to damage the oil seal.

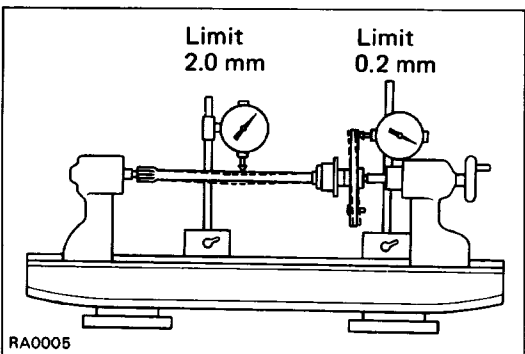
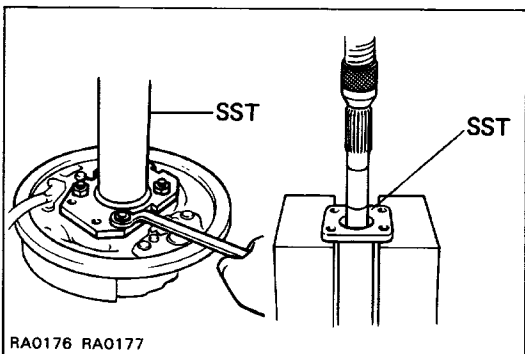

## INSPECTION AND REPAIR OF REAR AXLE SHAFT COMPONENTS

1. INSPECT REAR AXLE SHAFT AND FLANGE FOR WEAR, DAMAGE OR RUNOUT

Maximum shaft runout: 2.0 mm (0.079 in.)

Maximum flange runout: 0.2 mm (0.008 in.)

If the rear axle shaft or flange is damaged or worn, or if runout is greater than maximum, replace the rear axle shaft.

2. INSPECT OUTER OIL SEAL

(a) Check for damage.

(b) Check the oil seal lip for wear or damage.

If necessary, replace the oil seal.

3. REMOVE OUTER OIL SEAL

Using SST, remove the oil seal.

SST 09308-00010

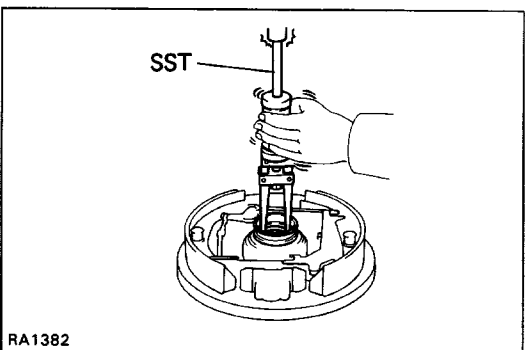

4. INSPECT REAR AXLE BEARING

Check for wear or damage.

5. IF NECESSARY, REPLACE REAR AXLE BEARING

(a) Using SST, press out the bearing.

SST 09223-56010 and 09608-35014 (09608-06100)

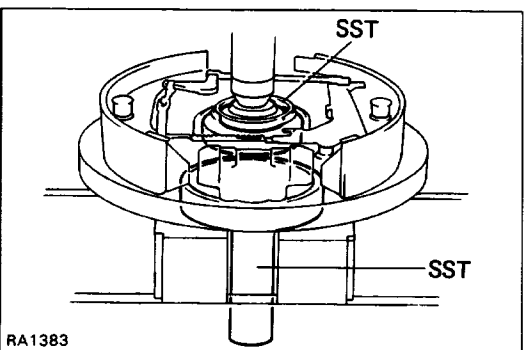



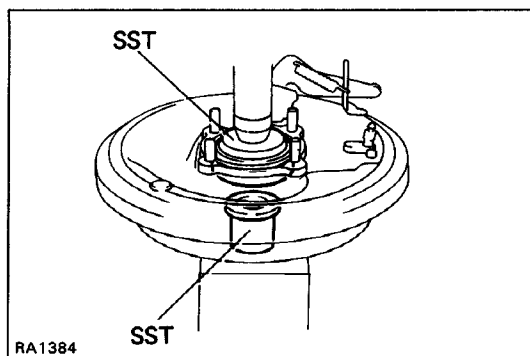

- (b) Using SST, press in a new bearing.  
SST 09515-30010 and 09608-35014 (09608-06180)

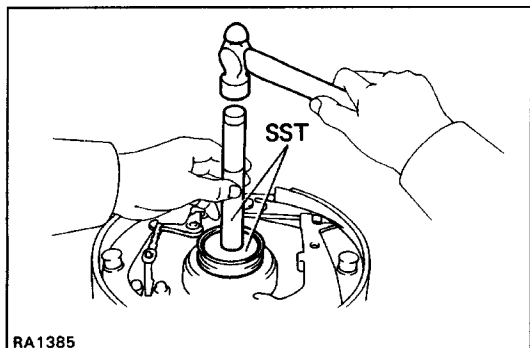

#### 6. INSTALL NEW OUTER OIL SEAL

- Using SST, tap in a new oil seal.  
SST 09608-30012 (09608-04020, 09608-04070)

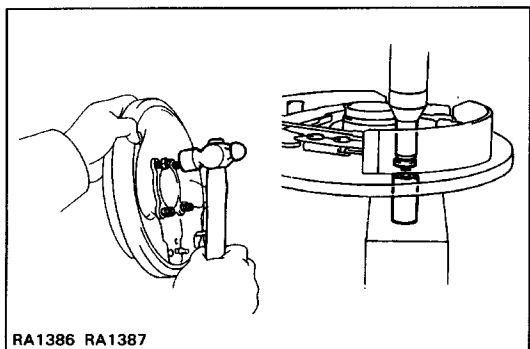

#### 7. INSPECT BEARING CASE

Check for wear or damage.

#### 8. IF NECESSARY, REPLACE BEARING CASE

- Remove the oil seal and bearing.
- Install nuts to the serration bolts.
- Using a hammer, tap out the serration bolts and remove the bearing case.
- Position the backing plate on the new bearing case and, using two socket wrenches, press in the serration bolts.
- Install a new bearing and oil seal.

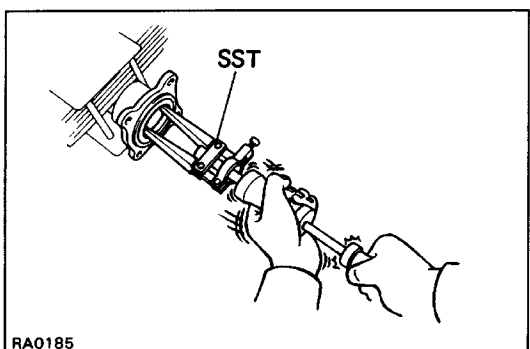

#### 9. INSPECT OIL SEAL FOR WEAR OR DAMAGE

#### 10. IF NECESSARY, REPLACE OIL SEAL

- Using SST, remove the oil seal.  
SST 09308-00010
- Apply MP grease to the oil seal.
- Using SST, drive in a new oil seal.  
SST 09608-30012 (09608-04020, 09608-04100)

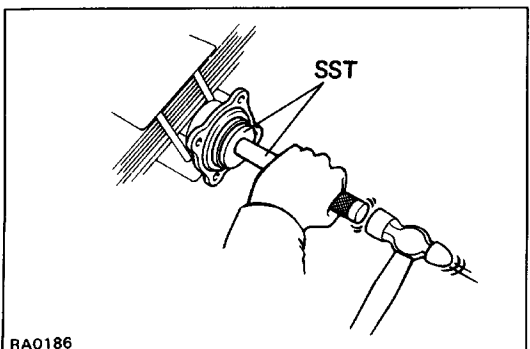

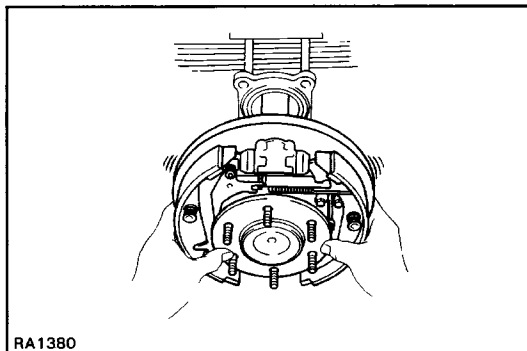
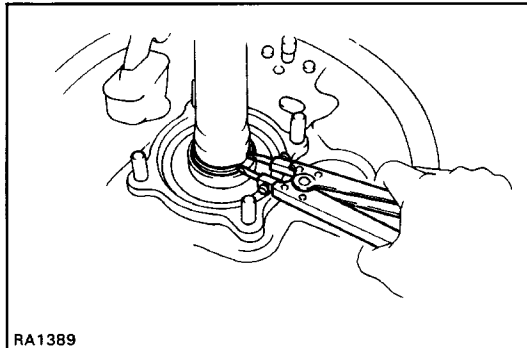
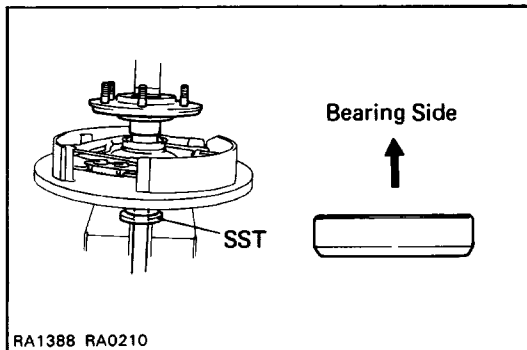

## INSTALLATION OF REAR AXLE SHAFT

(See page SA-123)

### 1. INSTALL REAR AXLE SHAFT IN BACKING PLATE

- (a) Apply MP grease to the oil seal lip.
- (b) Install the backing plate and bearing retainer on the rear axle shaft.
- (c) Using SST, press the rear axle shaft into the backing plate.  
SST 09515-30010
- (d) Using snap ring pliers, install a new snap ring.

### 2. INSTALL REAR AXLE SHAFT INTO HOUSING

Install the rear axle with four nuts.

**Torque: 59 N·m (700 kgf·cm, 51 ft·lbf)**

HINT:

- Be careful not to damage the oil seal.
- When inserting the axle shaft, be careful not to hit or deform the oil deflector inside the axle housing.

### 3. CONNECT BRAKE TUBE AND PARKING BRAKE CABLE

### 4. INSTALL BRAKE DRUM AND WHEEL

### 5. BLEED BRAKE SYSTEM

# REAR AXLE SHAFT AND AXLE HUB (Double Tire)

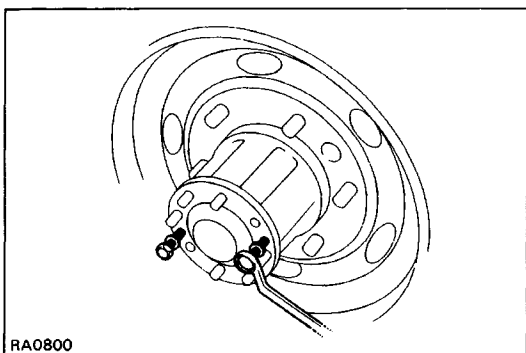
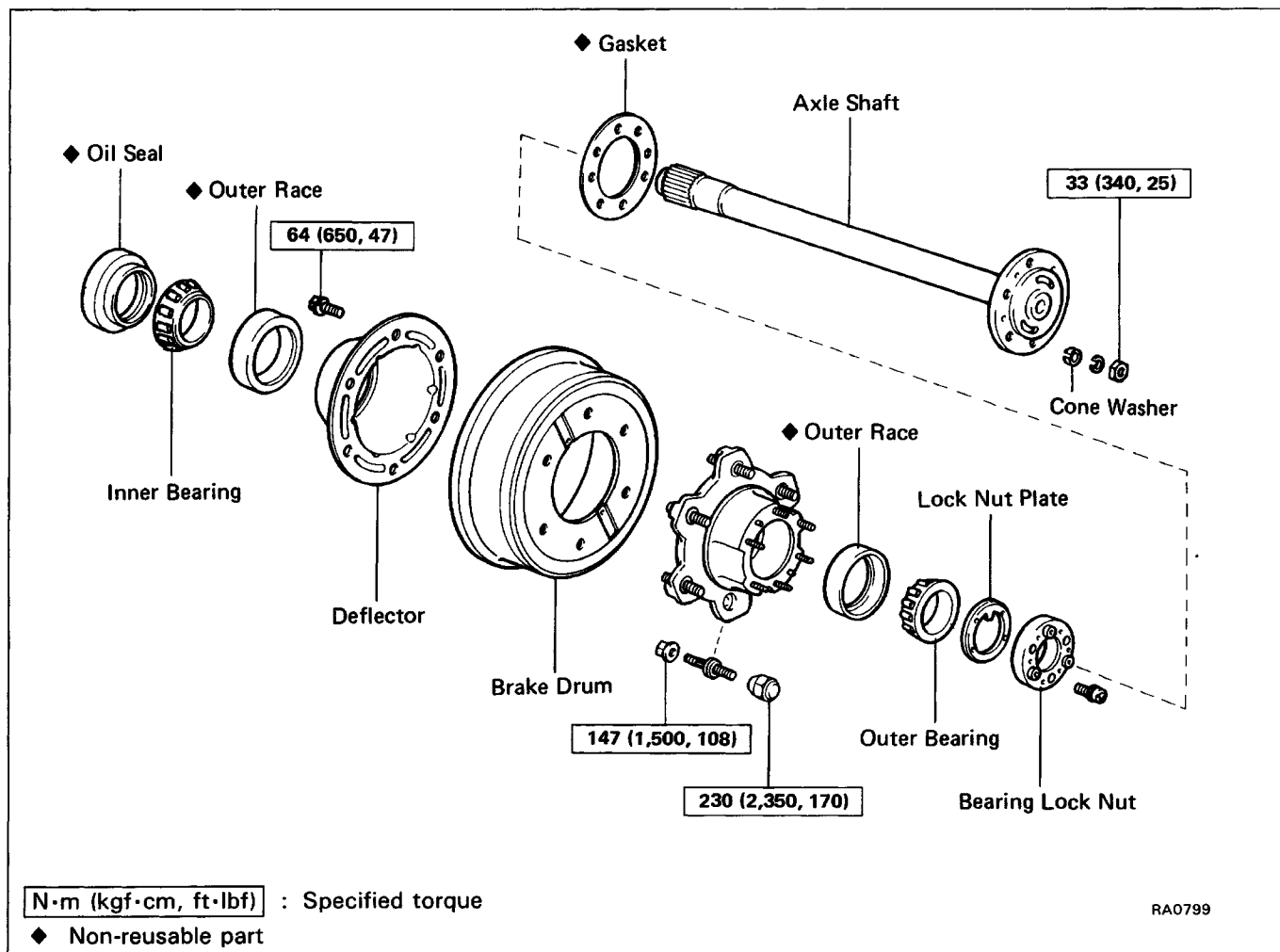

## REMOVAL OF REAR AXLE SHAFT

### 1. REMOVE CONE WASHERS

- Remove the six nuts and washers.
- Install two service bolts and one turn.
- Tap on the shaft and remove the six cone washers.

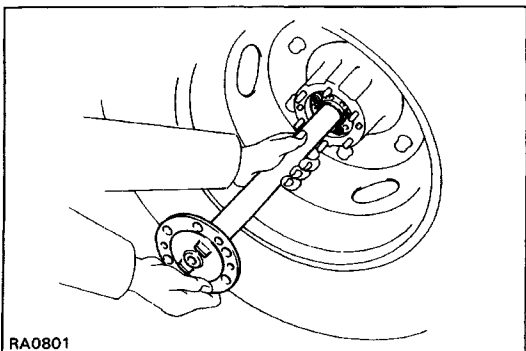

### 2. REMOVE REAR AXLE SHAFT

- Tighten the two service bolts and separate the axle shaft.
  - Remove the axle shaft with the gasket.
  - Remove the two service bolts.
- HINT: Be careful not to damage the oil seal with the splines.

## INSPECTION OF REAR AXLE SHAFT COMPONENTS

### 1. INSPECT REAR AXLE SHAFT

Check for wear, damage or runout.

**Maximum runout: 2.0 mm (0.079 in.)**

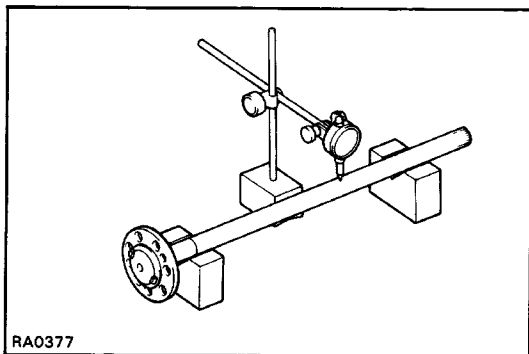

RA0377

### 2. INSPECT OIL SEAL FOR WEAR OR DAMAGE

If the oil seal is damaged or worn, replace it.

### 3. REPLACE OIL SEAL

(a) Using SST, remove the oil seal.

SST 09308-00010

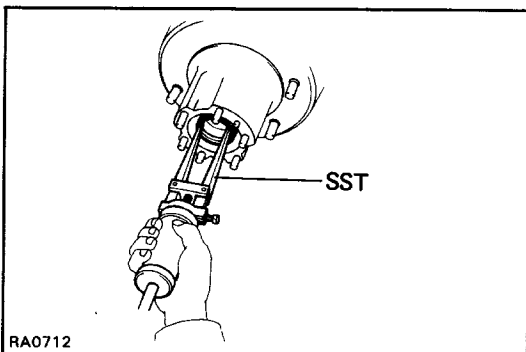

RA0712

(b) Using SST, drive in the oil seal.

SST 09517-12010

(c) Apply MP grease to the oil seal lip.

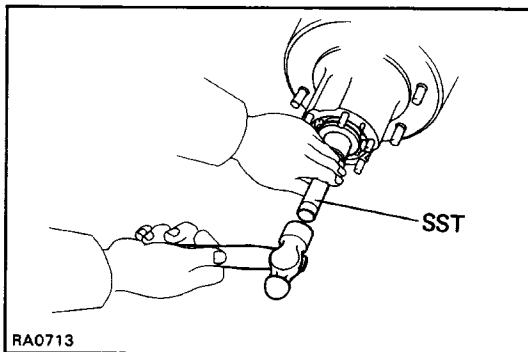

RA0713

## INSTALLATION OF REAR AXLE SHAFT

(See page SA-127)

### 1. APPLY MP GREASE TO OIL SEAL LIP

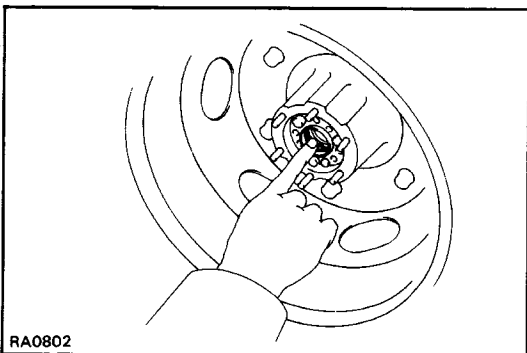

RA0802

### 2. INSTALL REAR AXLE SHAFT

Install the rear axle shaft, six cone washers and spring washers with nuts.

**Torque: 33 N-m (340 kgf-cm, 25 ft-lbf)**

**HINT:** Be careful not to damage the oil seal with the splines.

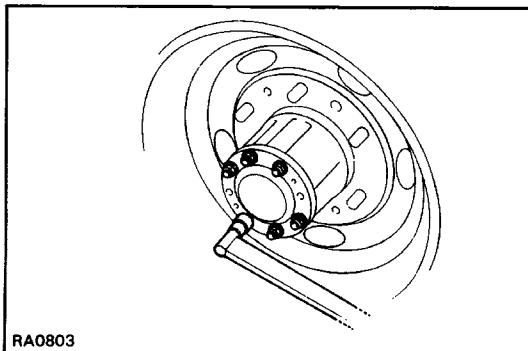

RA0803

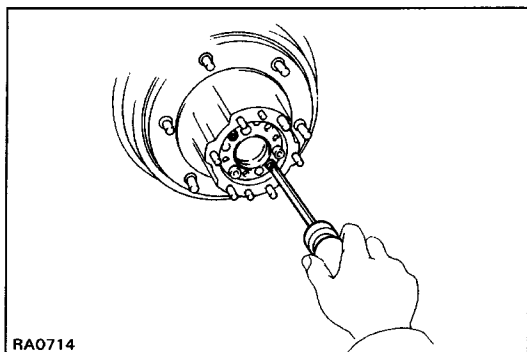

## DISASSEMBLY OF REAR AXLE HUB

### 1. REMOVE REAR WHEEL AND REAR AXLE SHAFT

(See page SA-127 )

### 2. REMOVE BEARING LOCK NUT

(a) Remove the two bolts from the bearing lock nut.

(b) Using SST, remove the bearing lock nut.

SST 09509-25011

(c) Remove the bearing lock plate.

### 3. REMOVE AXLE HUB FROM AXLE

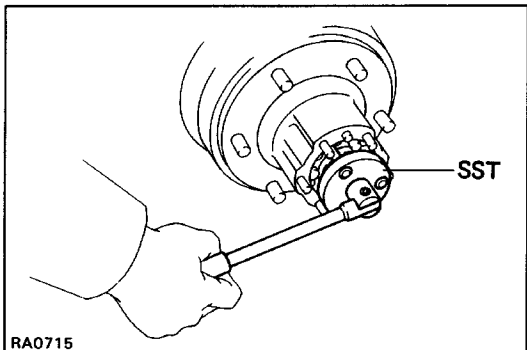

### 4. REMOVE OIL SEAL AND INNER BEARING

(a) Using SST, remove the oil seal from the axle hub.

SST 09308-00010

(b) Remove the inner bearing from the axle hub.

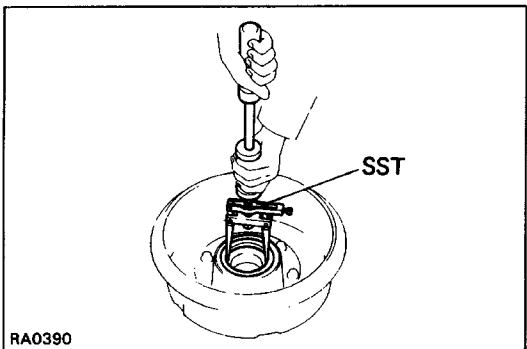

## INSPECTION AND REPAIR OF REAR AXLE HUB

### 1. INSPECT AXLE HOUSING

Using a magnetic flaw detector or flaw detecting penetrant, check for damage or cracks.

### 2. REPLACE BEARING OUTER RACE

(a) Using a hammer and brass bar, drive out the outer race.

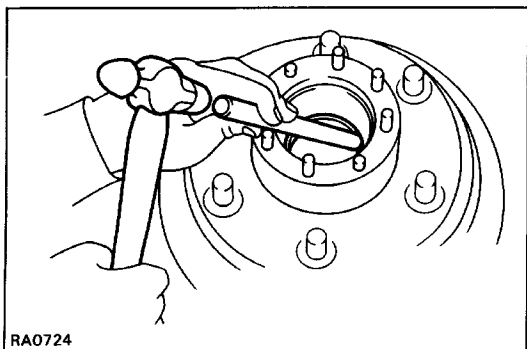

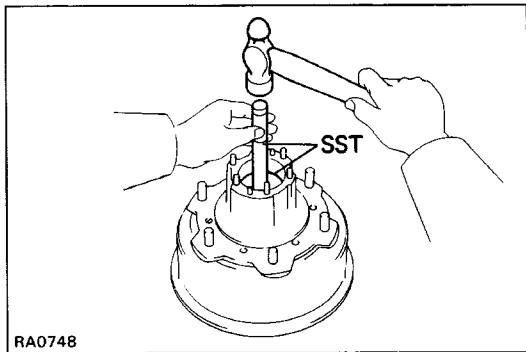

- (b) Using SST, carefully tap in a new bearing outer race.  
 SST Inner side 09608-35014  
 (09608-06020, 09608-06210)  
 Outer side 09608-35014  
 (09608-06020, 09608-06200)

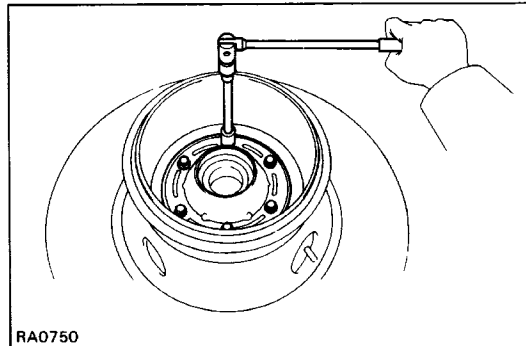

### 3. REPLACE HUB BOLT

- (a) Remove the six bolts and deflector.

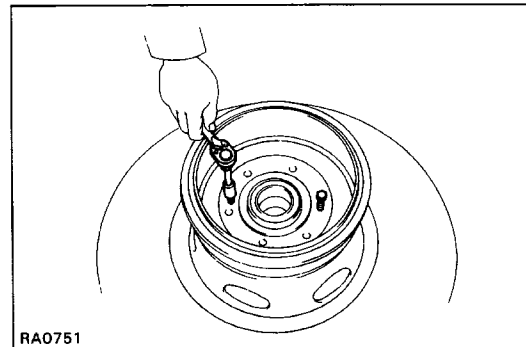

- (b) Using the two service bolts, separate the hub and brake drum.

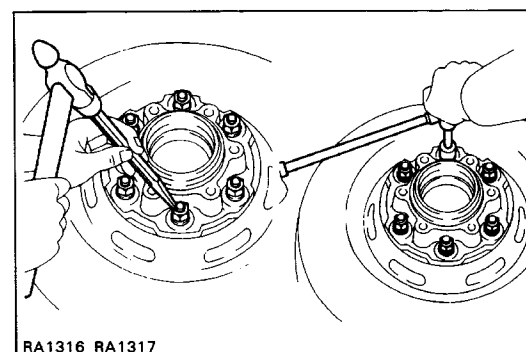

- (c) Unstake the bolt and remove the nut.

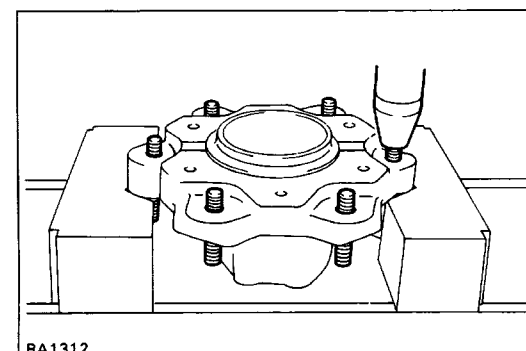

- (d) Using a press, press out the hub bolt.

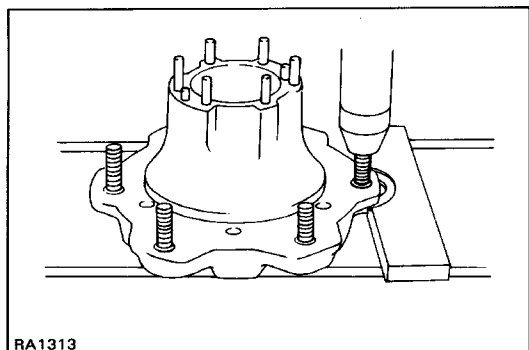

(e) Using a press, press in a new hub bolt.

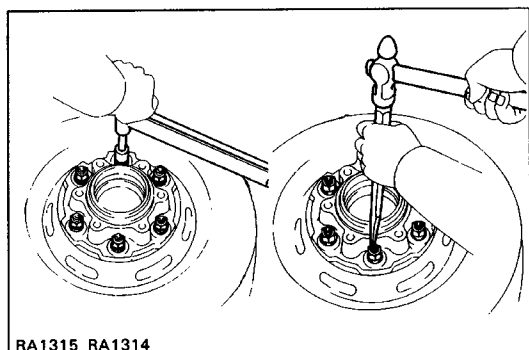

(f) Install and tighten the nut and stake the bolt.  
**Torque: 147 N-m (1,500 kgf-cm, 108 ft-lbf)**

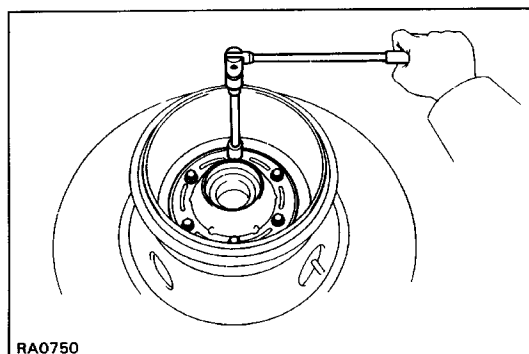

(g) Install the deflector and torque the six bolts.  
**Torque: 64 N-m (650 kgf-cm, 47 ft-lbf)**

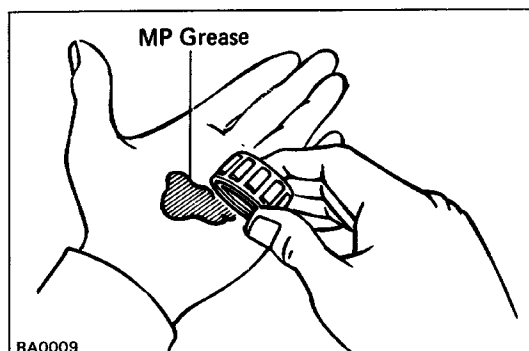

## ASSEMBLY OF REAR AXLE HUB

(See page [SA-127](#))

### 1. PACK BEARING WITH MP GREASE

- Place MP grease in the palm of your hand.
- Pack grease into the bearing, and continuing until the grease oozes out from the other side.
- Do the same around the bearing circumference.

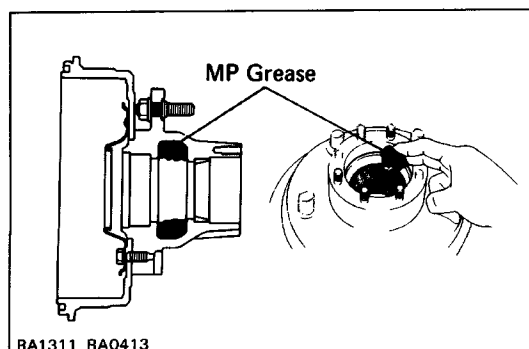

### 2. COAT SIDE HUB WITH MP GREASE

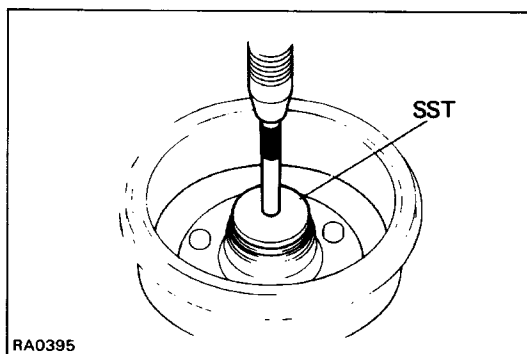

### 3. INSTALL INNER BEARING AND OIL SEAL

- (a) Place inner bearing into the hub.
- (b) Using SST, press in a new oil seal to the hub.  
SST 09608-35014 (09608-06020 and 09608-06180)

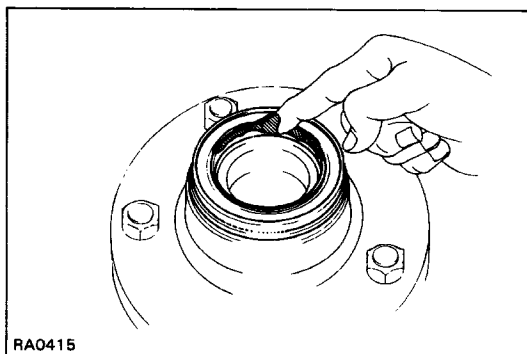

- (c) Apply MP grease to the oil seal lip.

### 4. INSTALL AXLE HUB ON AXLE HOUSING

- (a) Place the axle hub on the axle housing.
- (b) Install the outer bearing into the axle hub.

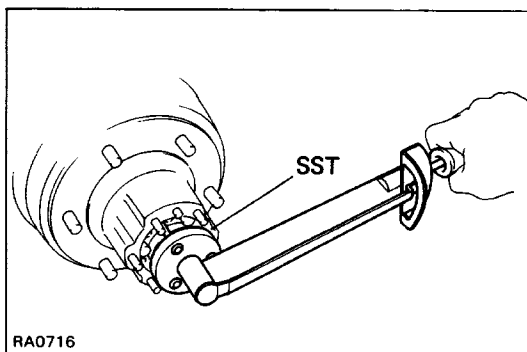

### 5. ADJUST PRELOAD

- (a) Install the lock plate.
- (b) Using SST, torque the bearing lock nut.  
SST 09509-25011  
Torque: 59 N-m (600 kgf-cm, 43 ft-lbf)

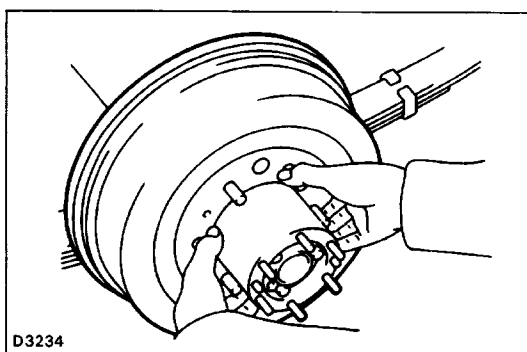

- (c) Snug down the bearing by turning the hub several times.

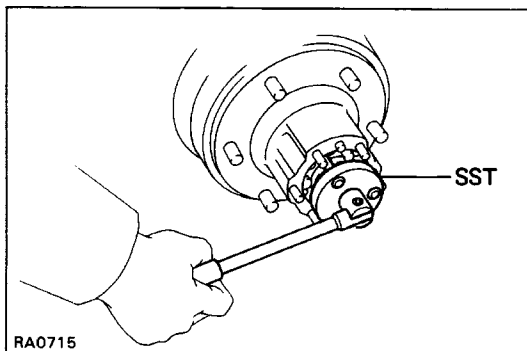

- (d) Using SST, retighten the bearing lock nut.  
SST 09509-25011  
Torque: 59 N-m (600 kgf-cm, 43 ft-lbf)
- (e) Using SST, loosen the bearing lock nut until you can rotate it by hand.  
SST 09509-25011



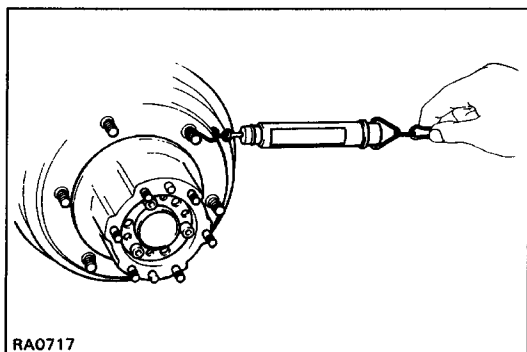

- (f) Using a spring tension gauge, measure and note friction force of the oil seal. (starting)  
 (g) Using SST, tighten the bearing lock nut until the preload is within the specification below.  
 SST 09 509-2 5011

**Preload (starting):**

**Add oil seal frictional force**

**1.0 –14.7 N (0.1 –1.5 kgf, 0.2 –3.3 lbf )**

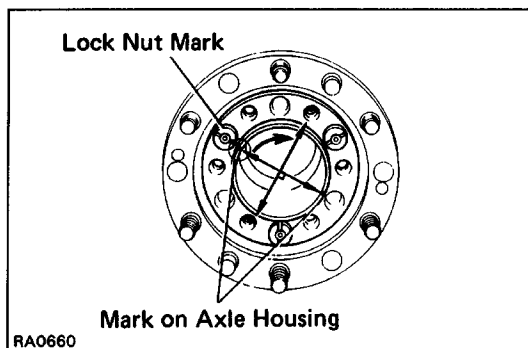

- (h) Align the lock nut mark with one of the marks on the axle housing, and place lock bolts in the holes at right angles to the lock nut.

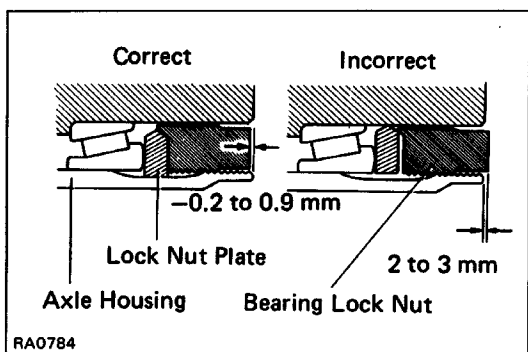

- (i) Measure the distance between the top surface of axle housing and the lock nut.  
 Standard distance: - 0.2 to 0.9 mm  
 (- 0.008 to 0.035 in.)  
 If not within specification, reinstall the axle hub.

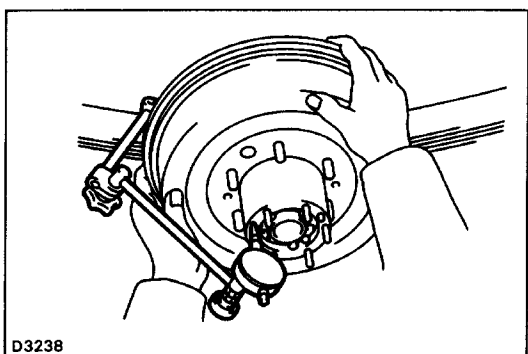

- (j) Check the movement of the drum.  
 (k) Check that has no axle play.

## 6. INSTALL REAR AXLE SHAFT

(See page [SA-128](#))

## 7. INSTALL WHEEL AND LOWER VEHICLE

# DIFFERENTIAL COMPONENTS

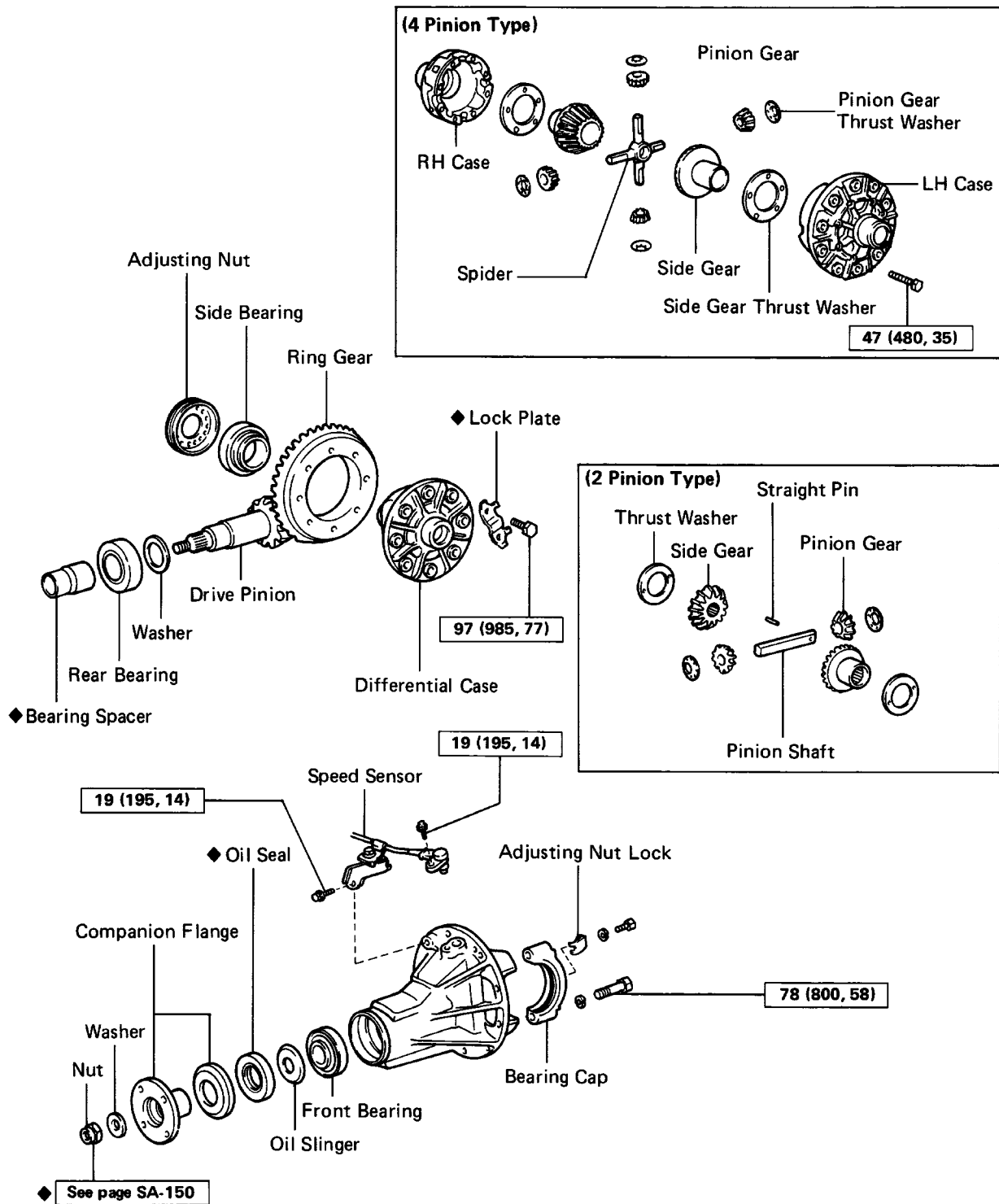

N·m (kgf·cm, ft·lbf) : Specified torque

◆ Non-reusable part

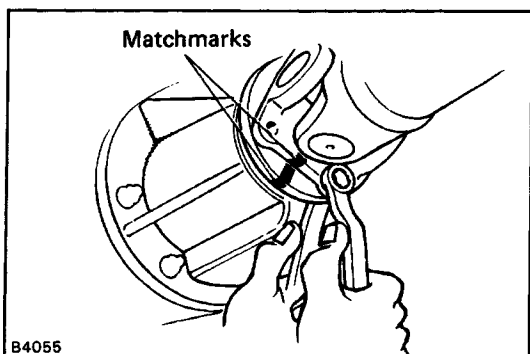

## ON-VEHICLE REPLACEMENT OF OIL SEAL

### 1. DISCONNECT PROPELLER SHAFT FROM DIFFERENTIAL

- Place matchmarks on the flanges.
- Remove the four bolts and nuts.

### 2. REMOVE COMPANION FLANGE

(See step 7 on page SA-138)

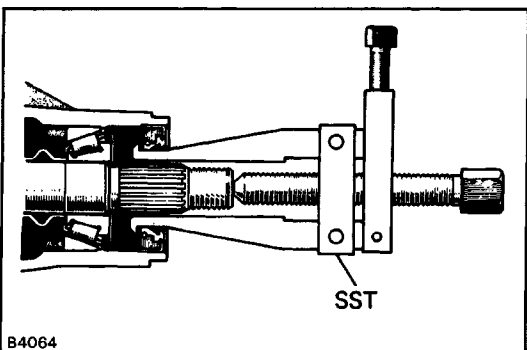

### 3. REMOVE OIL SEAL AND OIL SLINGER

- Using SST, remove the oil seal from the housing.  
SST 09308-10010
- Remove the oil slinger.

### 4. REMOVE FRONT BEARING AND BEARING SPACER

(See step 9 on page SA-138)

### 5. INSTALL NEW BEARING SPACER AND FRONT BEARING

(See step 12 on page SA-149)

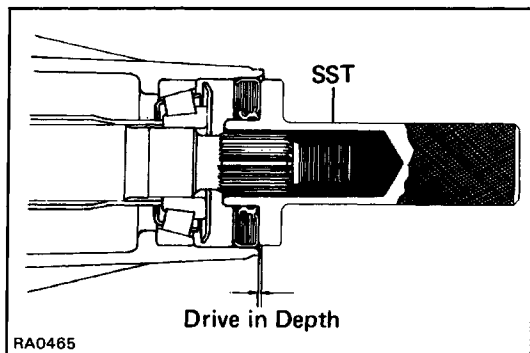

### 6. INSTALL OIL SLINGER AND NEW OIL SEAL

- Install the oil slinger facing as shown.
- Using SST, drive in a new oil seal as shown.  
SST 09554-30011  
Oil seal drive in depth:  
7.5 in. 1.5 mm (0.059 in.)  
8 in. 1.0 mm (0.039 in.)
- Apply MP grease to the oil seal lip.

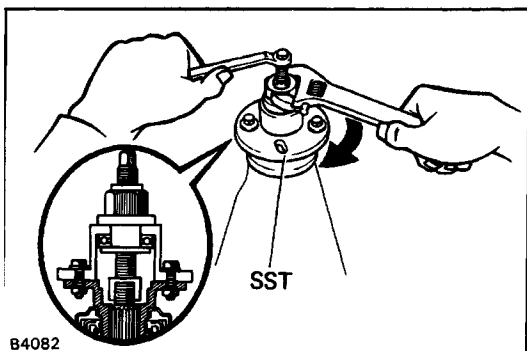

### 7. INSTALL COMPANION FLANGE

(See step 14 on page SA-149)

### 8. ADJUST DRIVE PINION BEARING PRELOAD

(See step 15 on page SA-150)

### 9. STAKE DRIVE PINION NUT

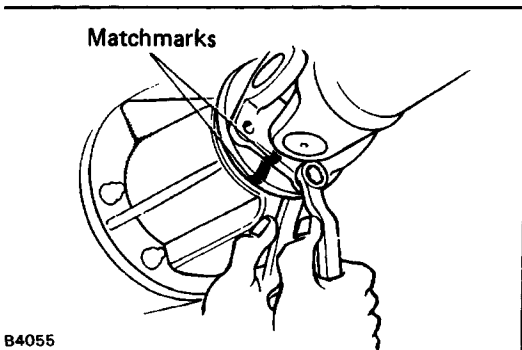

### 10. CONNECT PROPELLER SHAFT FLANGE TO COMPANION FLANGE

- Align the matchmarks on the flanges and connect the flanges with four bolts and nuts.
- Torque the four bolts and nuts.

Torque: 4WD 3VZ-E [MT]

76 N-m (780 kgf-cm, 56 ft-lbf)

Ex. 4WD 3VZ-E [MT]

74 N-m (750 kgf-cm, 54 ft-lbf)

**11. CHECK DIFFERENTIAL OIL LEVEL**

Fill with hypoid gear oil if necessary.

**Oil type:** API GL-5 hypoid gear oil

**Viscosity:** Above - 180C (0°F) SAE 90

Below - 180C (0°F)

SAE 80V1r or 80w-90

**Capacity:**

liters (US qts, Imp. qts)

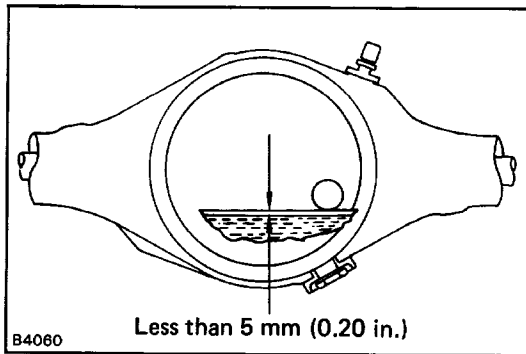

2W D	7.5 in.	2 pinion	1.35 (1.43, 1.19)
	8 in.	2 pinion	1.8 (1.9, 1.6)
4WD		8 in.	4 pinion
	2 pinion		2.2 (2.3, 1.9)
	4 pinion	2.2 (2.3, 1.9)	

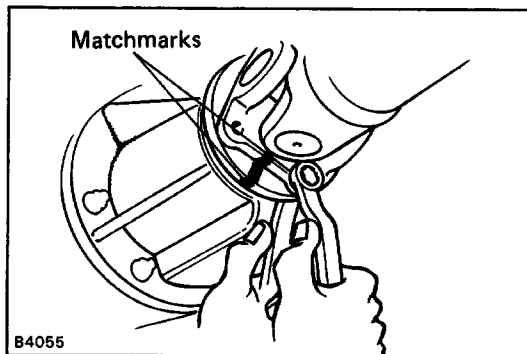
**REMOVAL OF DIFFERENTIAL**

1. REMOVE DRAIN PLUG AND DRAIN DIFFERENTIAL OIL
2. REMOVE REAR AXLE SHAFTS  
(See page [SA-124](#) or [SA-127](#))
3. DISCONNECT PROPELLER SHAFT FROM DIFFERENTIAL  
(See page [SA-135](#))

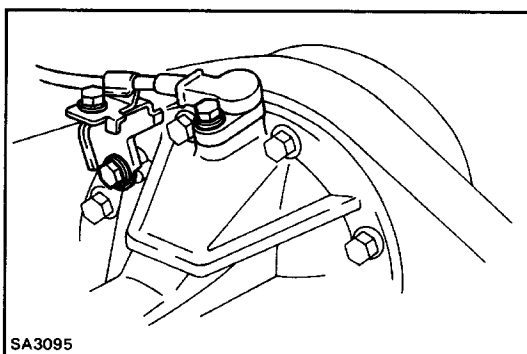

4. (w/ REAR-WHEEL ANTI-LOCK BRAKE SYSTEM)  
DISCONNECT SPEED SENSOR  
Remove the two bolts and the speed sensor.
5. REMOVE DIFFERENTIAL CARRIER ASSEMBLY

**DISASSEMBLY OF DIFFERENTIAL****(See page SA-134)**

HINT: If the differential is noisy, perform the following preinspection before disassembly to determine the cause.

If the differential has severe problems, disassemble and repair it as necessary.

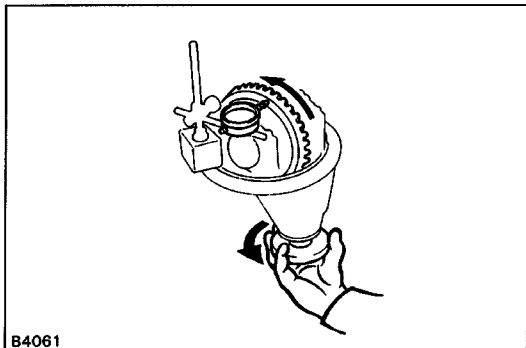

B4061

**1. CHECK RING GEAR RUNOUT**

If the runout is greater than maximum, install a new ring gear.

**Maximum runout:**

7.5 in. 0.07 mm (0.0028 in.)

8 in. 0.10 mm (0.0039 in.)

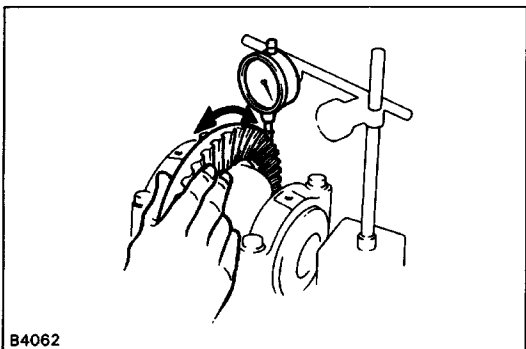

B4062

**2. CHECK RING GEAR BACKLASH**

If the backlash is not within specifications, adjust the side bearing preload or repair as necessary. (See step 8 on page SA-147)

**Backlash:** 0.13 – 0.18 mm (0.0051 – 0.0071 in.)

**3. INSPECT TOOTH CONTACT BETWEEN RING GEAR AND DRIVE PINION (See step 9 on page SA-149)**

Note the tooth contact position.

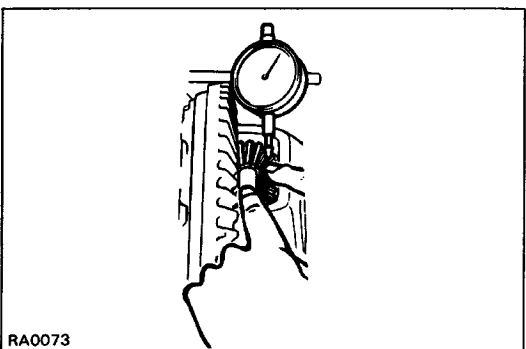

RA0073

**4. (2 PINION TYPE)****CHECK SIDE GEAR BACKLASH**

Measure the side gear backlash while holding one pinion gear toward the case.

**Standard backlash:**

0.05 – 0.20 mm (0.0020 – 0.0079 in.)

If the backlash is not within specification, install the proper thrust washers.

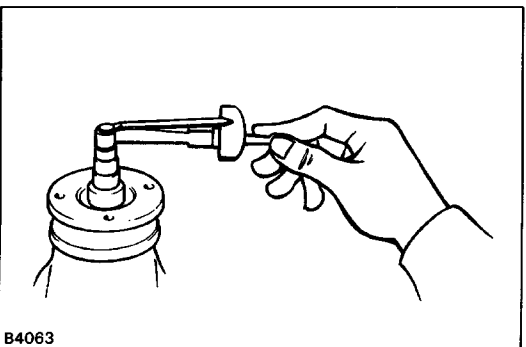

B4063

**5. MEASURE DRIVE PINION PRELOAD**

Using a torque meter, measure the preload of backlash between the drive pinion and ring gear.

**Preload (starting):**

7.5 in.

0.6 – 1.0 N-m (6 – 10 kgf-cm, 5.2 – 8.7 in.-lbf)

8 in.

(2 pinion type)

0.9 – 1.3 N-m (9 – 13 kgf-cm, 7.8 – 11.3 in.-lbf)

(4 pinion type)

0.5 – 0.8 N-m (5 – 8 kgf-cm, 4.3 – 6.9 in.-lbf)

**6. CHECK TOTAL PRELOAD**

Using a torque meter, measure the total preload.

**Total preload (starting):**

**Add drive pinion preload**

**0.4 – 0.6 N-m (4 – 6 kgf-cm, 3.5 – 5.2 in.-lbf)**

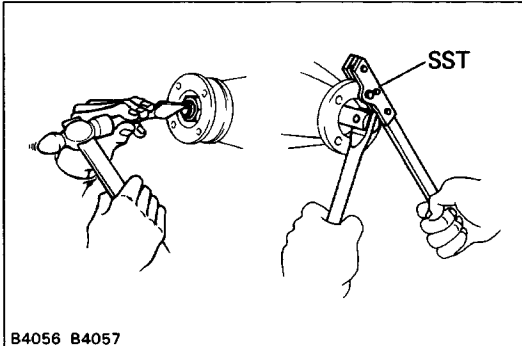

B4056 B4057

**7. REMOVE COMPANION FLANGE**

(a) Using a hammer and chisel, loosen the staked part of the nut.

(b) Using SST to hold the flange, remove the nut.  
SST 09330-0002 1

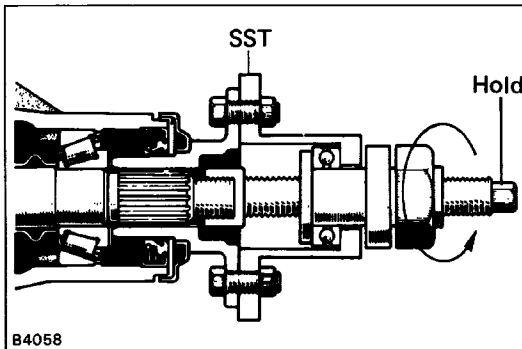

B4058

(c) Using SST, remove the companion flange.

SST 09557-22022

( 7.5 in. 09557-22030)

(8 in. 09557-22050)

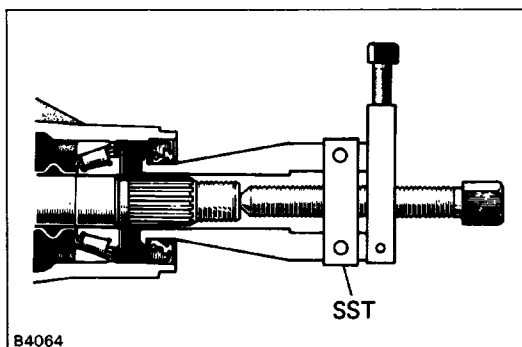

B4064

**8. REMOVE OIL SEAL AND OIL SLINGER**

(a) Using SST, remove the oil seal from the housing.

SST 09308-10010

(b) Remove the oil slinger.

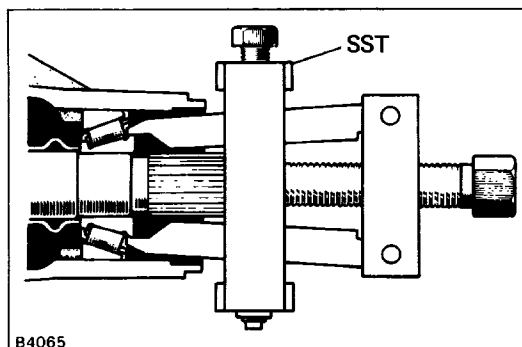

B4065

**9. REMOVE FRONT BEARING AND BEARING SPACER**

(a) Using SST, remove the front bearing from the drive pinion.

SST 09556-30010

(b) Remove the bearing spacer.

If the front bearing is damaged or worn, replace the bearing.

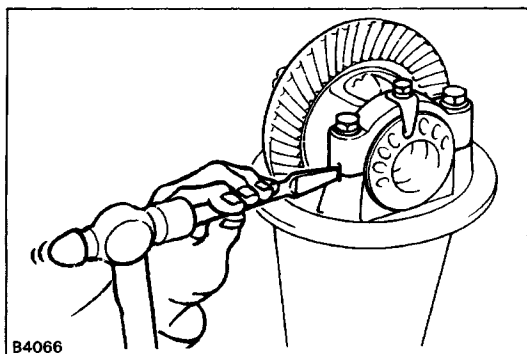

## 10. REMOVE DIFFERENTIAL CASE AND RING GEAR

- (a) Place matchmarks on the bearing cap and differential carrier.
- (b) Remove the two adjusting nut locks.
- (c) Remove the two bearing caps and two adjusting nuts.
- (d) Remove the bearing outer races.
- (e) Remove the differential case from the carrier.

B4066

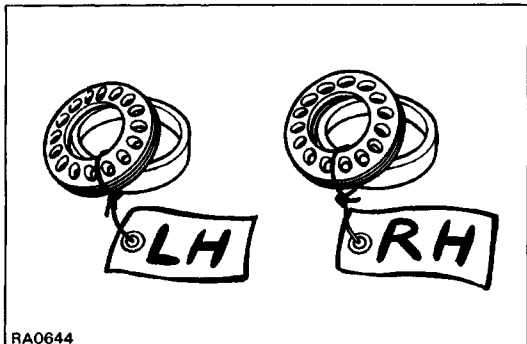

RA0644

HINT: Tag the disassembled parts to show the location for reassembly.

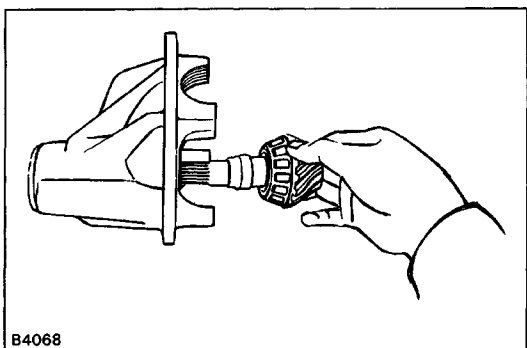

B4068

## 11. REMOVE DRIVE PINION FROM DIFFERENTIAL CARRIER

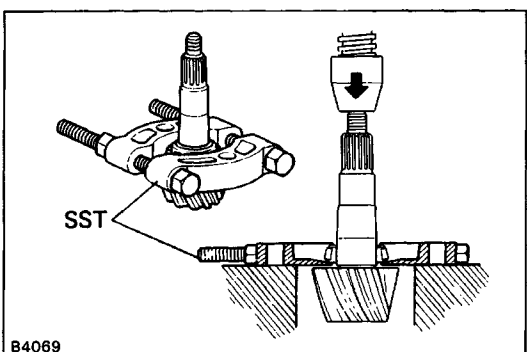

B4069

## 12. REPLACE DRIVE PINION REAR BEARING

- (a) Using a press and SST, pull out the rear bearing from the drive pinion.  
SST 09950-00020

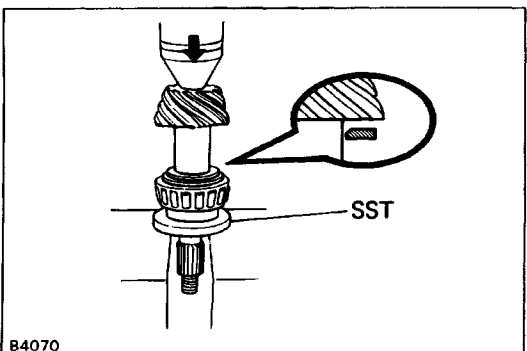

B4070

- (b) Install the washer on the drive pinion with the chamfered end facing the pinion gear.
- (c) Using a press and SST, press the reused washer and new rear bearing on the drive pinion.  
SST 09506-30012

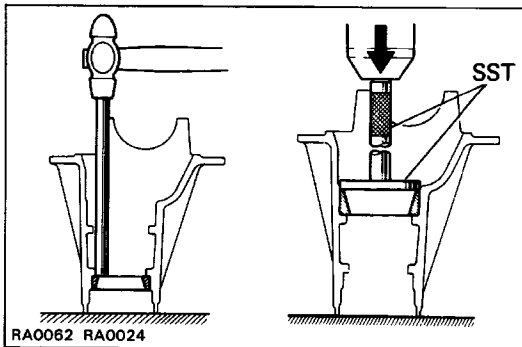

### 13. REPLACE DRIVE PINION FRONT AND REAR BEARING OUTER RACES

(a) Using a hammer and brass bar, drive out the outer race.

(b) Using a press and SST, drive in a new outer race.

SST

Front side 09608-35014 (09608-06020, 09608-06110)

Rear side

8 in. 4 pinion type

09608-35014 (09608-06020, 09608-06180)

Others 09608-35014 (09608-06020, 09608-06120)

### 14. REMOVE SIDE BEARINGS FROM DIFFERENTIAL CASE

Using SST, pull the side bearing from the differential case.

SST 09950-20017

HINT: Fix the claws of SST to the notches in the differential case.

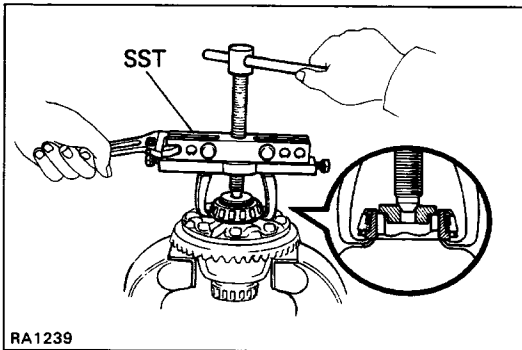

### 15. REMOVE RING GEAR

(a) Remove the ring gear set bolts and lock plates.

(b) Place alignment marks on the ring gear and differential case.

(c) Using plastic or copper hammer, tap on the ring gear to separate it from the differential case.

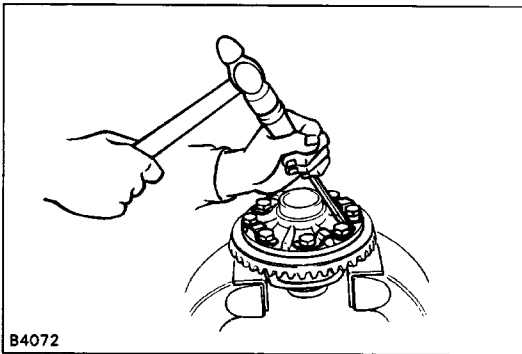



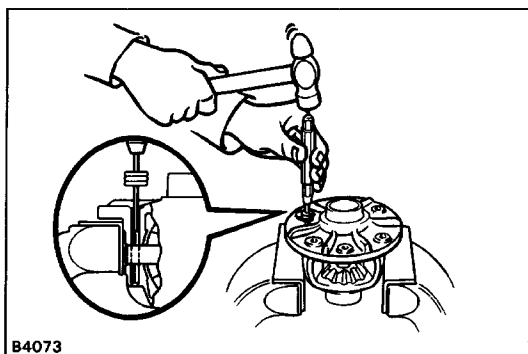

B4073

## REPLACEMENT OF DIFFERENTIAL CASE COMPONENT PARTS

### (2 Pinion Type)

#### 1. DISASSEMBLE DIFFERENTIAL CASE

Using a hammer and punch, drive out the straight pin. Remove the pinion shaft, two pinion gears, two side gears and two thrust washers.

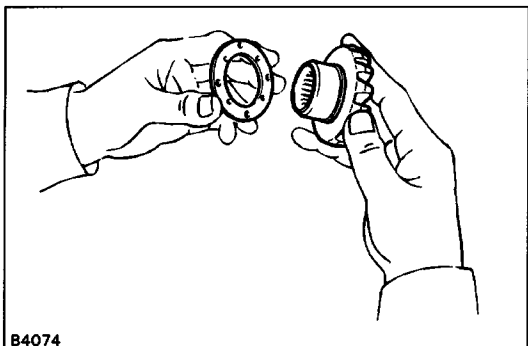

B4074

#### 2. ASSEMBLE DIFFERENTIAL CASE

(a) Install the proper thrust washers and side gears.

Using the table below, select thrust washers which will ensure that the backlash is within specification.

Try to select washers of the same size for both sides.

**Standard backlash: 0.05 – 0.20 mm**

**(0.0020 – 0.0079 in.)**

Thrust washer thickness

7.5 in.		8 in.	
Thickness	mm (in.)	Thickness	mm (in.)
1.0	(0.039)	1.6	(0.063)
1.1	(0.043)	1.7	(0.067)
1.2	(0.047)	1.8	(0.071)
1.3	(0.051)		

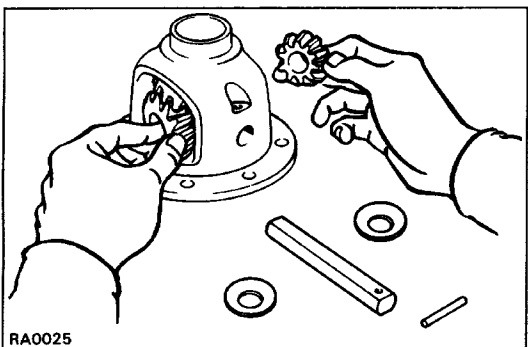

RA0025

Install thrust washers and side gears in the differential case.

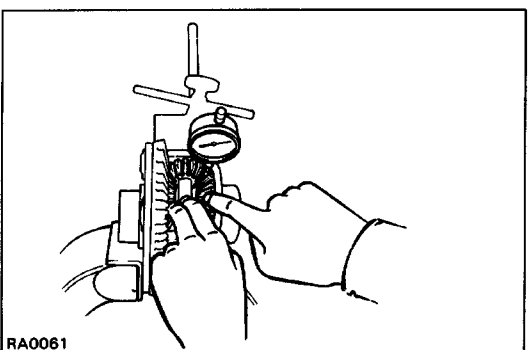

RA0061

(b) Check the side gear backlash.

Measure the side gear backlash while holding one pinion gear toward the case.

**Standard backlash: 0.05 – 0.20 mm**

**(0.0020 – 0.0079 in.)**

If the backlash is not within specification, install a thrust washer of different thickness.

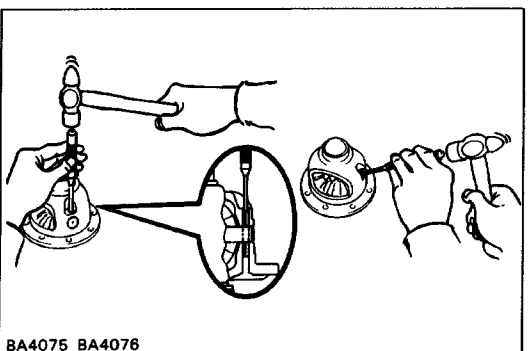

BA4075 BA4076

(c) Install the straight pin.

- Using the hammer and punch, drive the straight pin through the case and hole in the pinion shaft.
- Stake the pin and differential case.

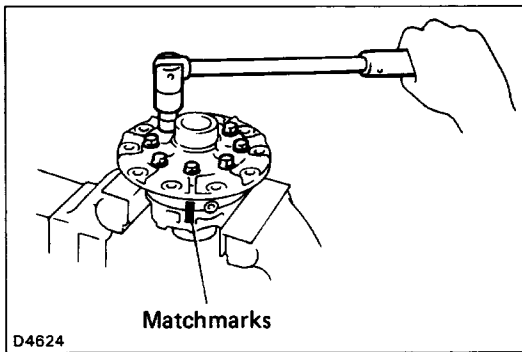
**(4 Pinion Type)****1. DISASSEMBLE DIFFERENTIAL CASE**

- (a) Place the matchmarks on the LH and RH cases.
- (b) Remove the eight bolts.

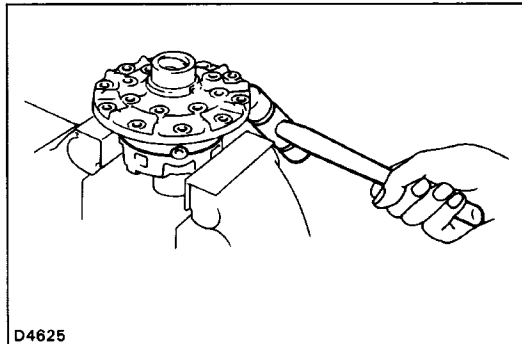

- (c) Using a plastic hammer, separate the LH and RH cases.

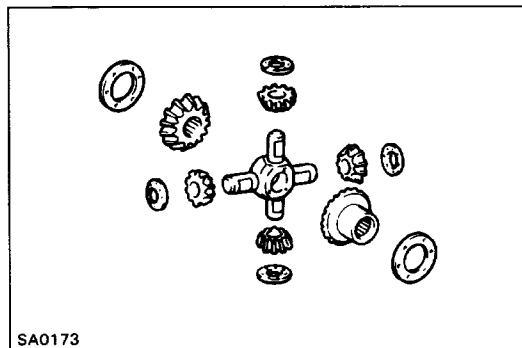
**2. REMOVE FOLLOWING PARTS FROM CASE:**

- Two side gears
- Two side gears thrust washers
- Spider
- Four pinion gears
- Four pinion gear thrust washers

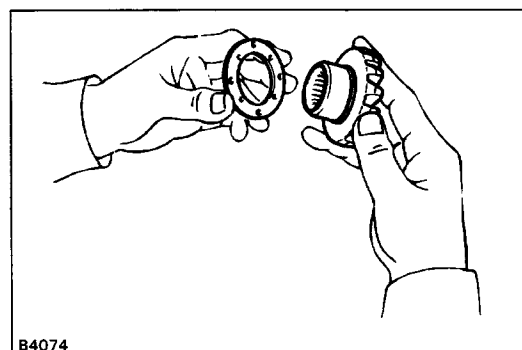
**3. MEASURE SIDE GEAR BACKLASH**

- (a) Install the thrust washer to the side gear.
- (b) Install the side gear to the RH case.

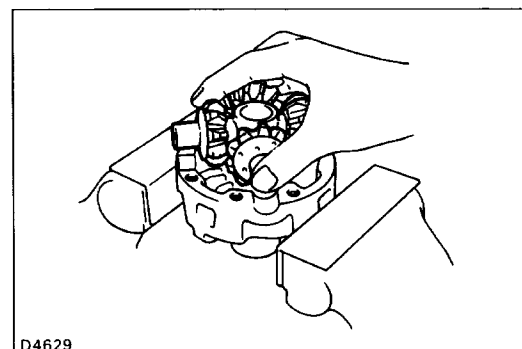

- (c) Install the four pinion gears and thrust washers to the spider.
- (d) Install the pinion gear and spider to the RH case.

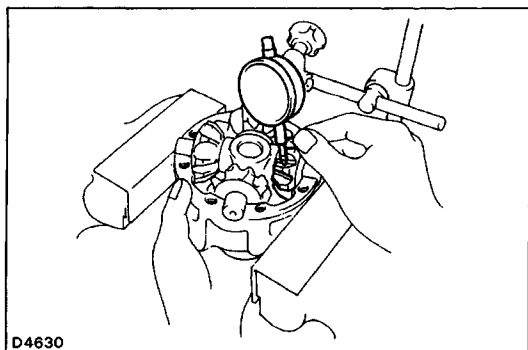

(e) Hold the side gear, measure the side gear backlash.

**Backlash: 0.05 – 0.20 mm (0.0020 – 0.0079 in.)**

HINT: Measure the backlash at the RH case at the LH case.

(f) If the backlash is not within specification, install a thrust washer of a different thickness.

HINT: Use washer of the same thickness on both the right and left sides.

Thickness		mm (in.)	
0.9	(0.035)	1.2	(0.047)
1.0	(0.039)	1.3	(0.051)
1.1	(0.043)		

#### 4. ASSEMBLE DIFFERENTIAL CASE

(a) Install the side gear and thrust washer to the RH case.

(b) Install the pinion gears and spider to the RH case.

(c) Install the side gear and thrust washer to the LH case.

(d) Apply gear oil to the each parts.

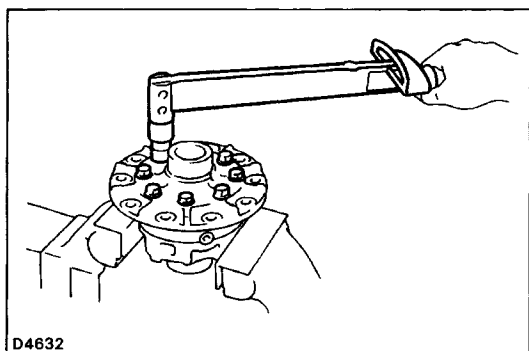

(e) Align the matchmarks on the LH and RH case.

(f) Torque the eight bolts.

**Torque: 47 N-m (480 kgf-cm, 35 ft-lbf)**

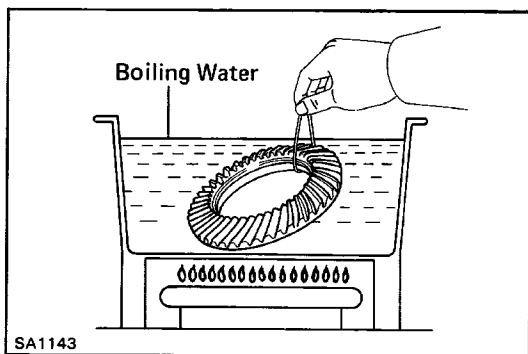

## ASSEMBLY OF DIFFERENTIAL

### 1. INSTALL RING GEAR ON DIFFERENTIAL CASE

- (a) Clean the contact surfaces of the differential case and ring gear.
- (b) Heat the ring gear in boiling water.
- (c) After the moisture on the ring gear has completely evaporated, quickly install the ring gear to the differential case.

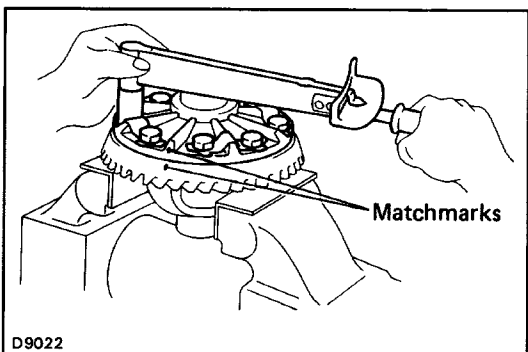

- (d) Align the matchmarks on the ring gear and differential case.
- (e) Coat the ring gear set bolts with gear oil.
- (f) Temporarily install the lock plates and set bolts.
- (g) After the ring gear cools down enough, tighten the set bolts uniformly and a little at a time.

**Torque: 97 N-m (985 kgf-cm, 71 ft-lbf)**

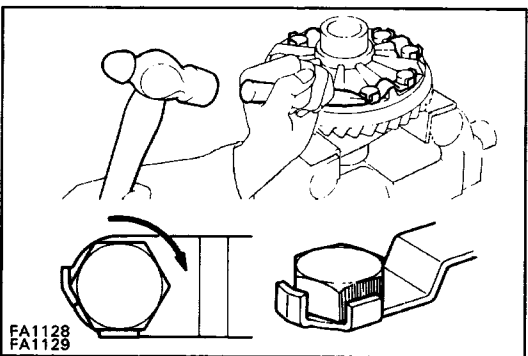

- (h) Using a hammer and drift punch, stake the lock plates.  
HINT: Stake one claw flush with the flat surface of the bolt. For the claw contacting the protruding portion of the bolt, stake only the half on the tightening side.

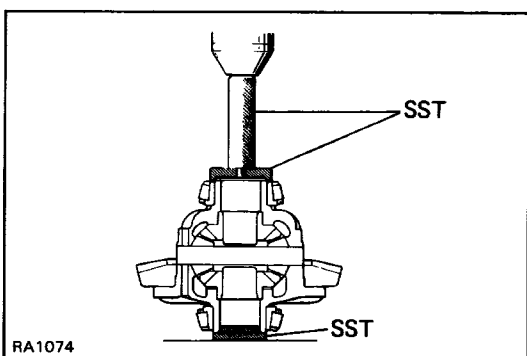

### 2. INSTALL SIDE BEARINGS

Using a press and SST, press the side bearings on the differential case.

SST 09550-10012

(09252-10010, 09557-10010, 09558-10010)

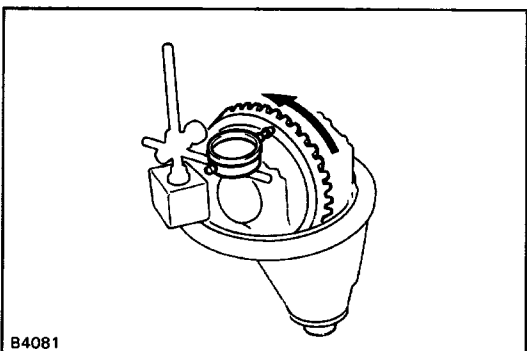

### 3. CHECK RING GEAR RUNOUT

- (a) Install the differential case onto the carrier and tighten the adjusting nut just to where there is no play in the bearings.
- (b) Check the ring gear runout.

**Maximum runout:**

7.5 in. 0.07 mm (0.0028 in.)

8 in. 0.10 mm (0.0039 in.)

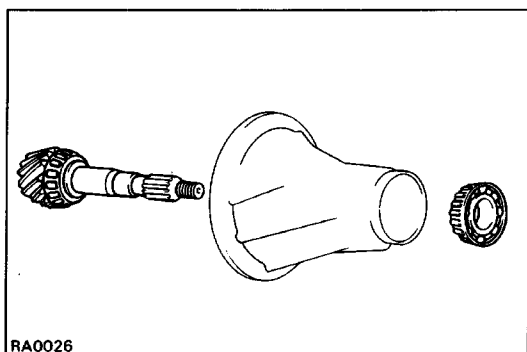

RA0026

#### 4. TEMPORARILY ADJUST DRIVE PINION PRELOAD

(a) Install the following parts.

- Drive pinion
- Front bearing

HINT: Assemble the spacer, oil slinger and oil seal after adjusting the gear contact pattern.

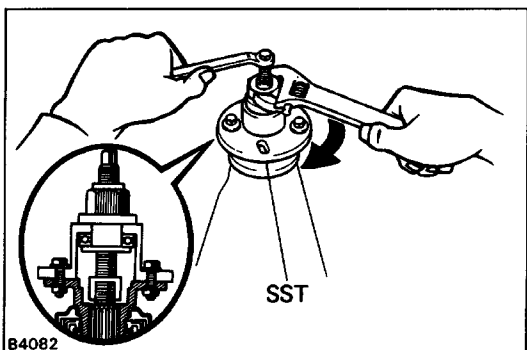

B4082

(b) Install the companion flange with SST.

SST 09557-22022

(7.5 in. 09557-22030)

(8 in. 09557-22050)

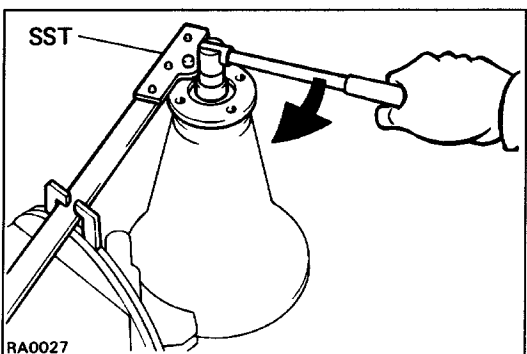

RA0027

(c) Adjust the drive pinion preload by tightening the companion flange nut.

Using SST to hold the flange, tighten the nut.

SST 09330-00021

**NOTICE:** As there is no spacer, tighten a little at a time, being careful not to overtighten.

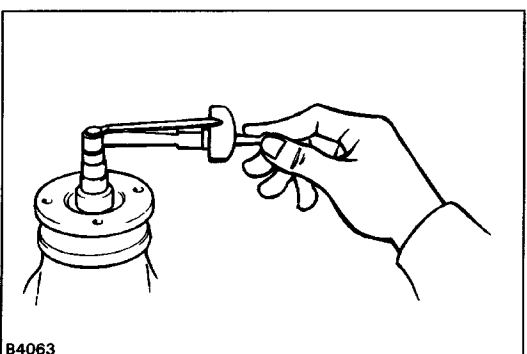

B4063

(d) Using a torque meter, measure the preload.

**Preload (starting):**

**New bearing**

7.5 in.

1.2 – 1.9 N-m

(12 – 19 kgf-cm, 10.4 – 16.5 in.-lbf)

8 in.

(2 pinion type)

1.9 – 2.5 N-m

(19 – 25 kgf-cm, 16.5 – 22.6 in.-lbf)

(4 pinion type)

1.0 – 1.6 W

(10 – 16 kgf-cm, 8.7 – 13.9 in.-lbf)

**Reused bearing**

7.5 in.

0.6 – 1.0 N-m

(6 – 10 kgf-cm, 5.2 – 8.7 in.-lbf)

8 in.

(2 pinion type)

0.9 – 1.3 N-m

(9 – 13 kgf-cm, 7.8 – 11.3 in.-lbf)

(4 pinion type)

0.5 – 0.8 N-

(5 – 8 kgf-cm, 4.3 – 6.9 in.-lbf)

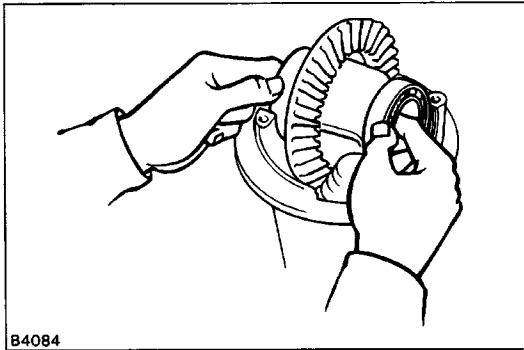

B4084

### 5. INSTALL DIFFERENTIAL CASE IN CARRIER

- (a) Place the bearing outer races on their respective bearings. Make sure the left and right outer races are not interchanged.
- (b) Install the case in the carrier.

HINT: Make sure that there is backlash between the ring gear and drive pinion.

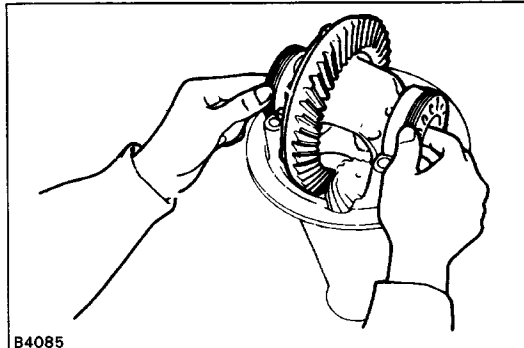

B4085

### 6. INSTALL ADJUSTING NUTS

Install the adjusting nuts on the carrier, making sure the nuts are threaded properly.

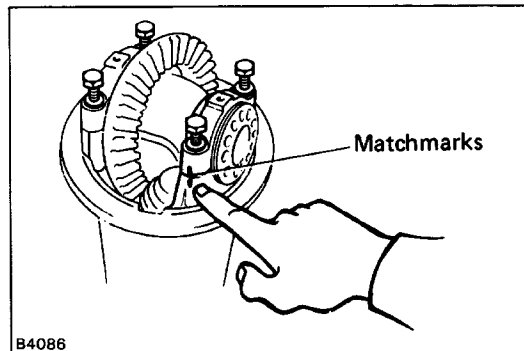

B4086

### 7. INSTALL BEARING CAPS

Align the matchmarks on the cap and carrier. Screw in the two bearing cap bolts two or three turns and press down the bearing cap by hand.

HINT: If the bearing cap does not fit tightly on the carrier, the adjusting nuts are not threaded properly. Reinstall the adjusting nuts if necessary.

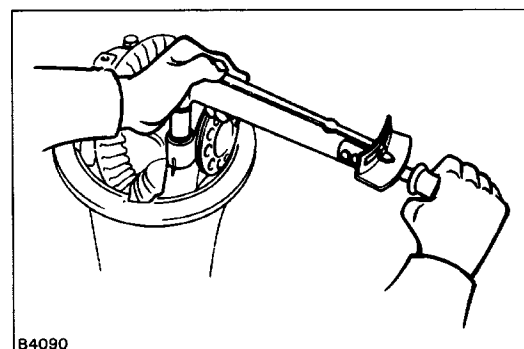

B4090

### 8. ADJUST SIDE BEARING PRELOAD

- (a) Tighten the four bearing cap bolts to the specified torque, then loosen them to the point where they can be turned by hand.

**Torque: 78 N-m (800 kgf-cm, 58 ft-lbf)**

- (b) Fully tighten the four bearing cap bolts by hand.

- (c) Using SST, tighten the adjusting nut on the ring gear side until the ring gear has a backlash of about 0.2 mm (0.008 in.)

SST 09 504-00011

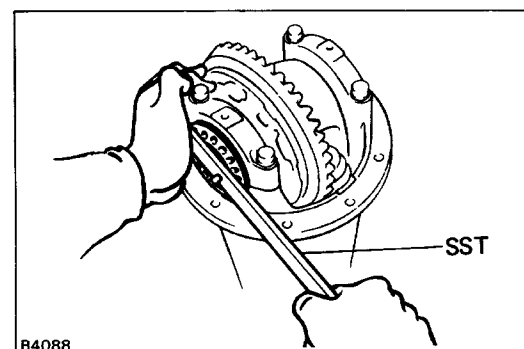

B4088

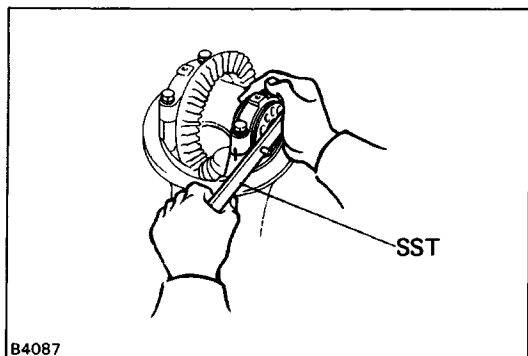

- (d) While turning the ring gear, use SST to fully tighten the adjusting nut on the drive pinion side. After the bearings are settled, loosen the adjusting nut on the drive pinion side.  
SST 09504-00011

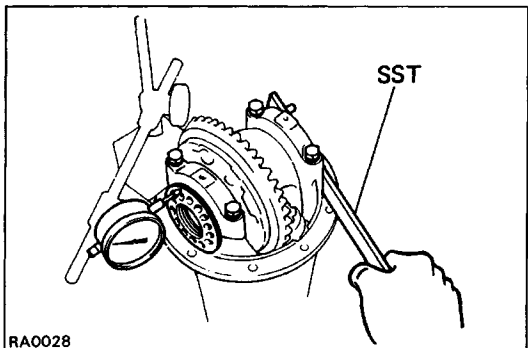

- (e) Place a dial indicator on the top of the adjusting nut on the ring gear side.  
(f) Adjust the side bearing for zero preload by tightening the other adjusting nut until the pointer on the indicator begins to move.

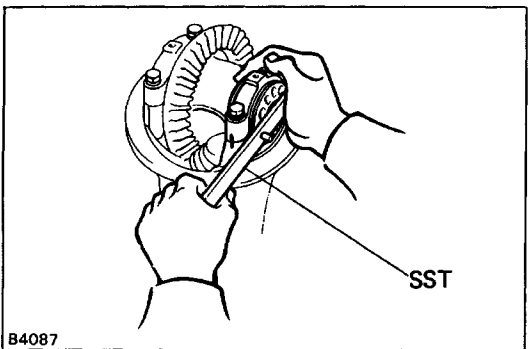

- (g) Tighten the adjusting nut 1 - 1/2 notches from the zero preload position.

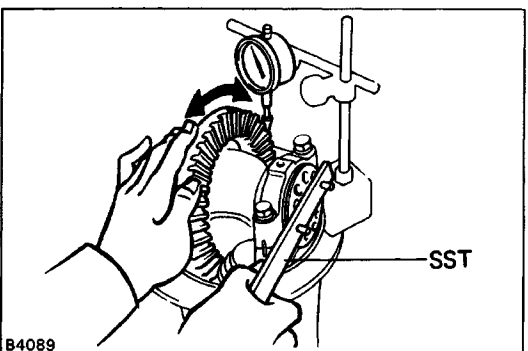

- (h) Using a dial indicator, adjust the ring gear backlash until it is within specification.  
**Backlash: 0.13 - 0.18 mm (0.0051 - 0.0071 in.)**  
HINT: The backlash is adjusted by turning the left and right adjusting nuts equal amounts. For example, loosen the nut on the left side one notch and tighten the nut on the right side one notch.

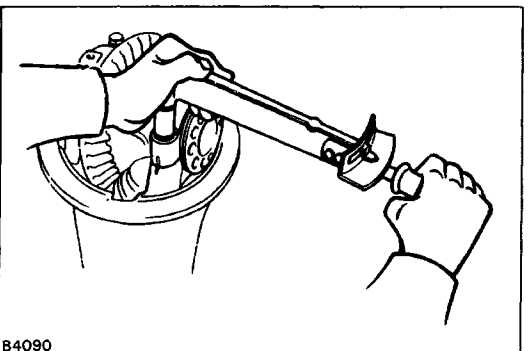

- (i) Torque the bearing cap bolts.  
**Torque: 78 N-m (800 kgf-cm, 58 ft-lbf)**  
(j) Recheck the ring gear backlash.  
**Backlash: 0.13 - 0.18 mm (0.0051 - 0.0071 in.)**

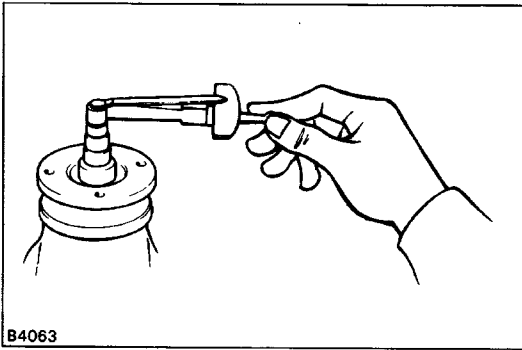

(k) Using a torque meter, measure the total preload.

**Total preload (starting):**

**Add drive pinion preload**

0.4 – 0.6 N-m

(4 – 6 kgf -cm, 3.5 – 5.2 in.-lbf)

**Backlash: 0.13 – 0.18 mm (0.0051 – 0.0071 in.)**

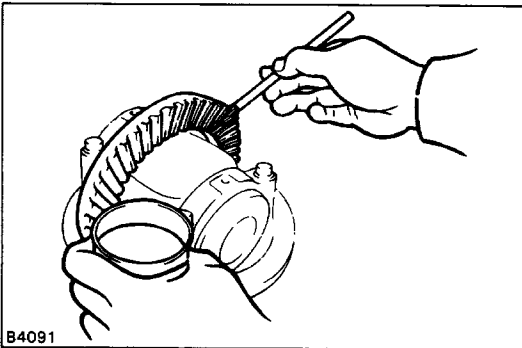

## 9. INSPECT TOOTH CONTACT BETWEEN RING GEAR AND DRIVE PINION

- Coat 3 or 4 teeth at three different positions on the ring gear with red lead.
- Hold the companion flange firmly and rotate the ring gear in both directions.
- Inspect the tooth pattern.

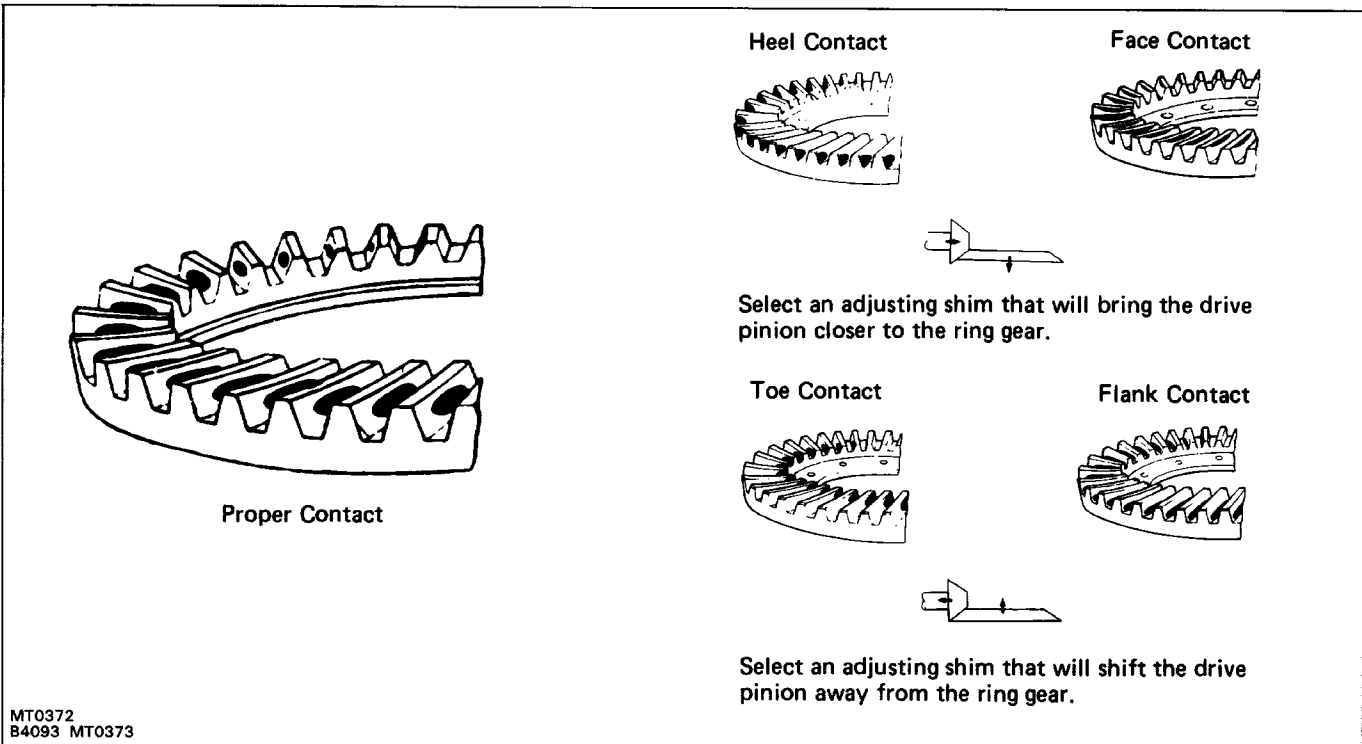



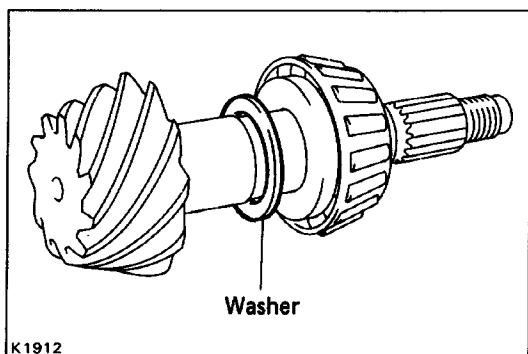

If the teeth are not contacting properly, use the following chart to select a proper washer for correction.

Washer thickness

7.5 in.		8 in.	
Thickness	mm (in.)	Thickness	mm (in.)
2.24	(0.0882)	1.70	(0.0669)
2.27	(0.0894)	1.73	(0.0681)
2.30	(0.0906)	1.76	(0.0693)
2.33	(0.0917)	1.79	(0.0705)
2.36	(0.0929)	1.82	(0.0717)
2.39	(0.0941)	1.85	(0.0728)
2.42	(0.0953)	1.88	(0.0740)
2.45	(0.0965)	1.91	(0.0752)
2.48	(0.0976)	1.94	(0.0764)
2.51	(0.0988)	1.97	(0.0776)
2.54	(0.1000)	2.00	(0.0787)
2.57	(0.1012)	2.03	(0.0799)
2.60	(0.1024)	2.06	(0.0811)
2.63	(0.1035)	2.09	(0.0823)
2.66	(0.1047)	2.12	(0.0835)
2.69	(0.1059)	2.15	(0.0846)
2.72	(0.1071)	2.18	(0.0858)
		2.21	(0.0870)
		2.24	(0.0882)
		2.27	(0.0894)
		2.30	(0.0906)
		2.33	(0.0917)

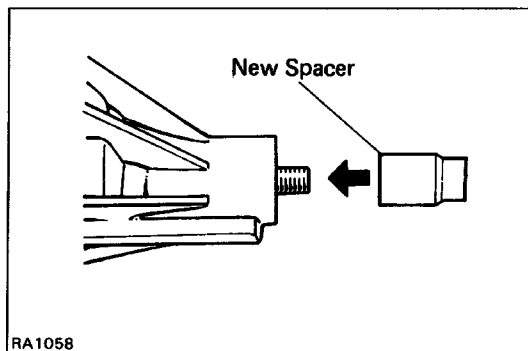

#### 10. REMOVE COMPANION FLANGE

(See step 7 on page SA-138)

#### 11 REMOVE FRONT BEARING

(See step 9 on page SA-138)

#### 12. INSTALL NEW BEARING SPACER AND FRONT BEARING

- Install a new bearing spacer on the shaft.
- Install the front bearing on the shaft.

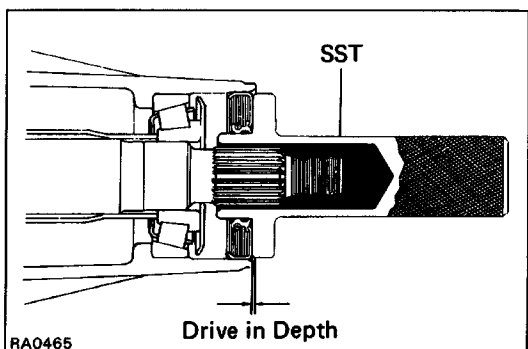

#### 13. INSTALL OIL SLINGER AND NEW OIL SEAL

- Install the oil slinger facing as shown.
- Using SST, drive in a new oil seal as shown.

SST 09554-30011

Oil seal drive in depth:

7.5 in. 1.5 mm (0.059 in.)

8 in. 1.0 mm (0.039 in.)

- Apply MP grease to the oil seal lip.

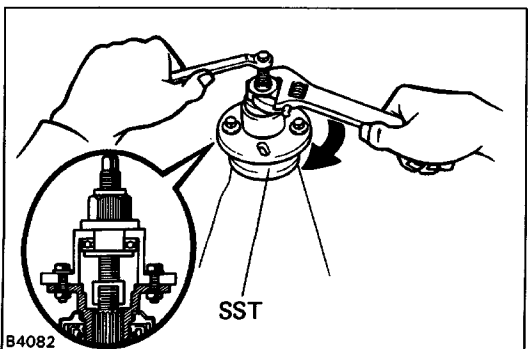

#### 14. INSTALL COMPANION FLANGE

- Install the companion flange with SST.

SST 09557-22022

(7.5 in. 09557-22030)

(8 in. 09557-22050)

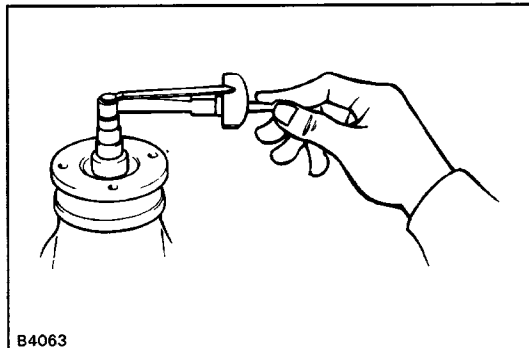
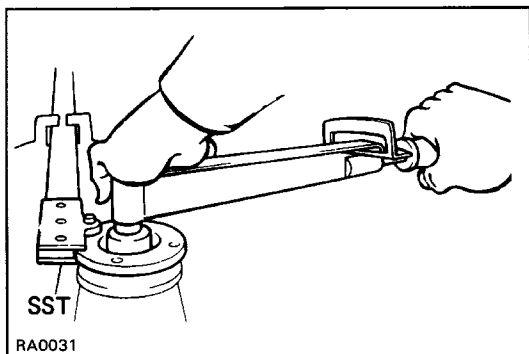

- (b) Coat the threads of a new nut with MP grease.  
 (c) Using SST to hold the flange, tighten the nut.  
 SST 09330-00021

**Torque:**

7.5 in.

108 N-m (1,100 kgf-cm, 80 ft-lbf)

8 in.

196 N-m (2,000 kgf-cm, 145 ft-lbf)

**15. ADJUST DRIVE PINION PRELOAD**

Using a torque meter, measure the preload of the backlash between the drive pinion and ring gear.

**Preload (starting):****New bearing**

7.5 in.

1.2 – 1.9 N-m

(12 – 19 kgf-cm, 10.4 – 16.5 in.-lbf)

8 in.

(2 pinion type)

1.9 – 2.5 N-m

(19 – 26 kgf-cm, 16.5 – 22.6-lbf)

(4 pinion type)

1.0 – 1.6 N-m

(10 – 16 kgf-cm, 8.7 – 13.9 in.-lbf)

**Reused bearing**

7.5 in.

0.6 – 1.0 N-m

(6 – 10 kgf-cm, 5.2 – 8.7 in.-lbf)

8 in.

(2 pinion type)

0.9 – 1.3 N-m

(9 – 13 kgf-cm, 7.8 – 11.3 in.-lbf)

(4 pinion type)

0.5 – 0.8 N-m

(5 – 8 kgf-cm, 4.3 – 6.9 in.-lbf)

- (a) If preload is greater than specification, replace the bearing spacer.  
 (b) If preload is less than specification, retighten the nut 13 N-m (130 kgf-cm, 9 ft-lbf) a little at a time until the specified preload is reached.

**Maximum torque:**

7.5 in.

235 N-m (2,400 kgf-cm, 174 ft-lbf)

8 in.

343 N-m (3,500 kgf-cm, 253 ft-lbf)

If the maximum torque is exceeded while retightening the nut, replace the bearing spacer and repeat the preload procedure. Do not back off the pinion nut to reduce the preload.

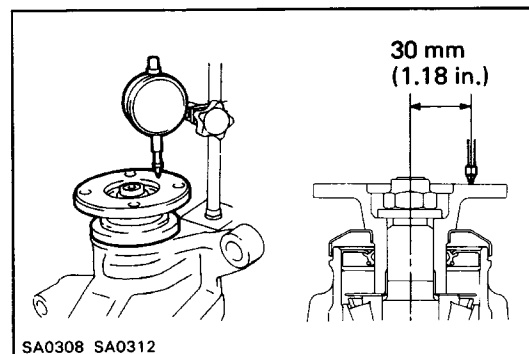
**16. CHECK RUNOUT OF COMPANION FLANGE**

**Maximum vertical runout: 0.10 mm (0.0039 in.)**

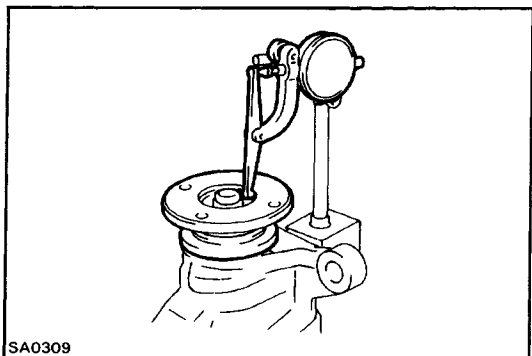

SA0309

Maximum lateral runout: 0.10 mm (0.0039 in.)

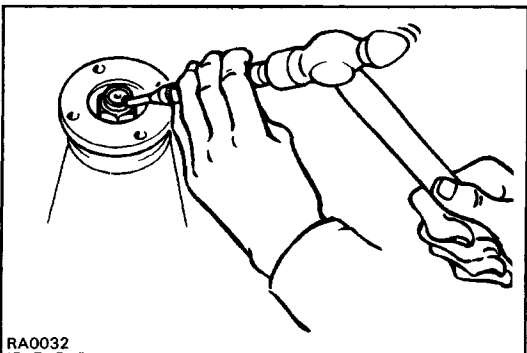

RA0032

### 17. STAKE DRIVE PINION NUT

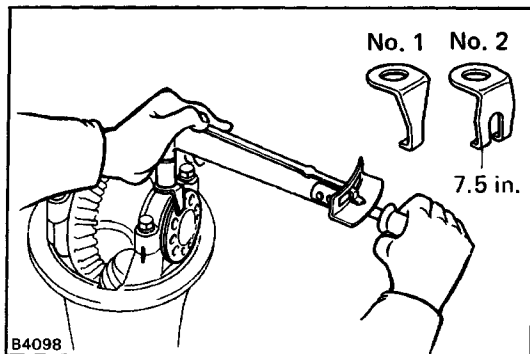

B4098

### 18. INSTALL ADJUSTING NUT LOCKS

(a) (7.5 in.)

Select either a lock No. 1 or No. 2, whichever will fit the adjusting nuts.

(b) Install the lock on the bearing caps.

**Torque: 13 N-m (130 kgf-cm, 9 ft-lbf)**

## INSTALLATION OF DIFFERENTIAL

(See page [SA-134](#))

### 1. INSTALL A NEW GASKET

### 2. INSTALL DIFFERENTIAL CARRIER ASSEMBLY

Install the differential carrier assembly in the axle and install the 10 nuts. Torque the nuts.

**Torque: Single tire 25 N-m (250 kgf-cm, 18 ft-lbf)**

**Double tire 31 N-m (315 kgf-cm, 23 ft-lbf)**

### 3. (w/ REAR-WHEEL ANTI-LOCK BRAKE SYSTEM)

#### CONNECT SPEED SENSOR

Connect the speed sensor with the two bolts.

**Torque: 19 N-m (195 kgf-cm, 14 ft-lbf)**

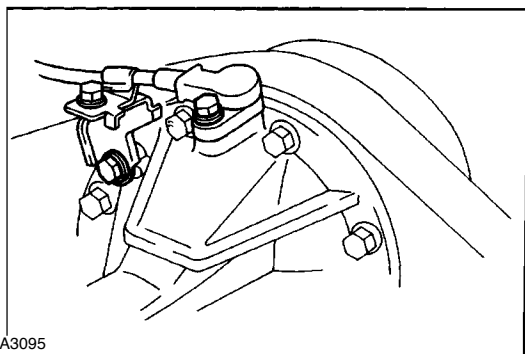

A3095

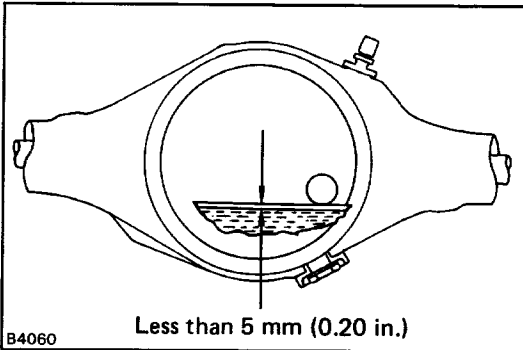
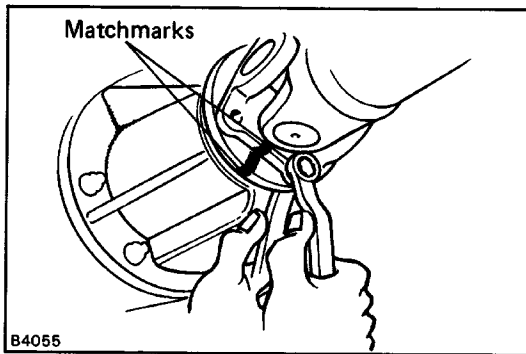

#### 4. CONNECT PROPELLER SHAFT FLANGE TO COMPANION FLANGE

- Align the matchmarks on the flanges and connect the flanges with four bolts and nuts.
- Torque the bolts and nuts.

**Torque: 4WD 3VZ-E [MT]**

76 N-m (780 kgf-cm, 56 ft-lbf)

**Ex. 4WD 3VZ-E [MT]**

74 N-m (750 kgf-cm, 54 ft-lbf)

#### 5. INSTALL DRAIN PLUG AND FILL DIFFERENTIAL WITH GEAR OIL

**Oil type: APL GL-5 hypoid gear oil**

**Viscosity: Above - 180C (0°F) SAE 90**

**Below - 180C (0°F)**

**SAE 80w or 80W-90**

**Capacity:**

liters (US qts, Imp. qts)

2W D	7.5 in.	2 pinion	1.35 (1.43, 1.19)
	8 in.	2 pinion	1.8 (1.9, 1.6)
		4 pinion	2.2 (2.3, 1.9)
4WD	8 in.	2 pinion	2.2 (2.3, 1.9)
		4 pinion	2.2 (2.3, 1.9)

Torque the filler plug.

**Torque: 49 N-m (500 kgf-cm, 36 ft-lbf)**

# REAR SUSPENSION

## Shock Absorber

### COMPONENTS

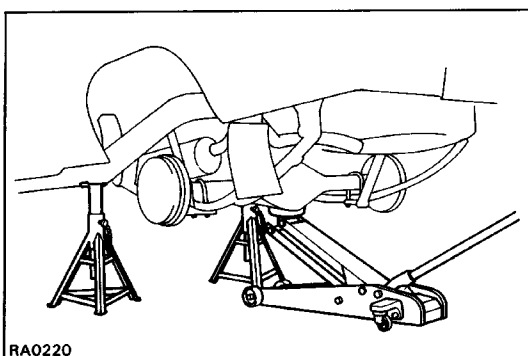
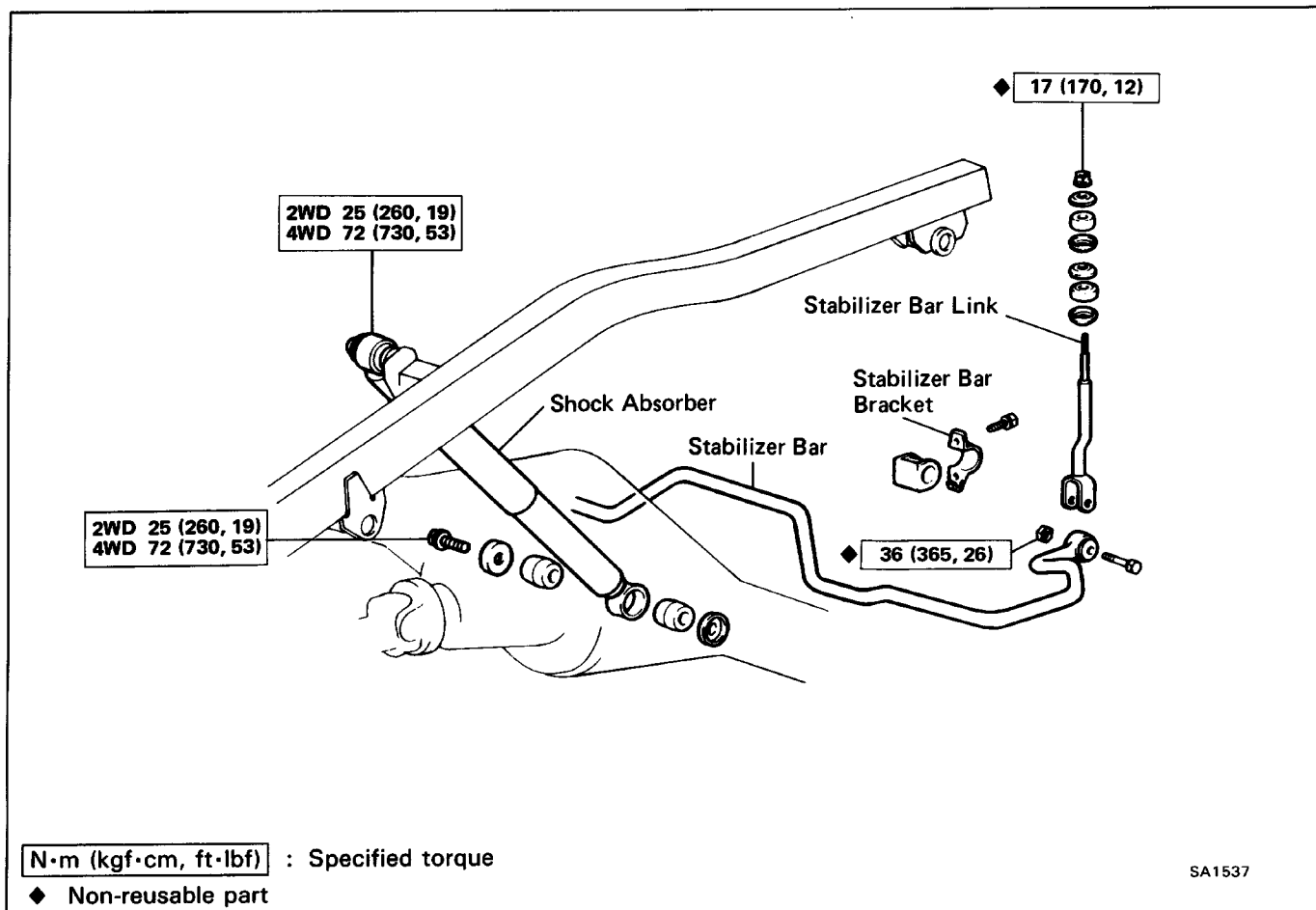

## REMOVAL OF SHOCK ABSORBER

### 1. JACK UP AND SUPPORT BODY

- Jack up and support the body on stands.
- Lower the axle housing until the leaf spring tension is free, and keep it at this position.

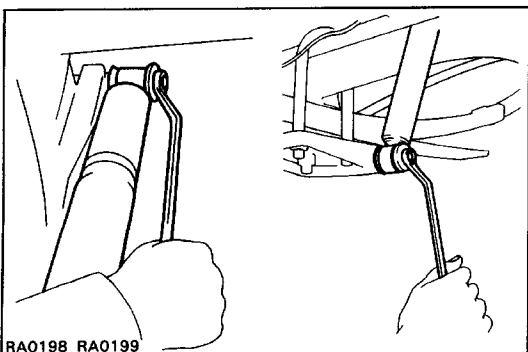

### 2. REMOVE SHOCK ABSORBER

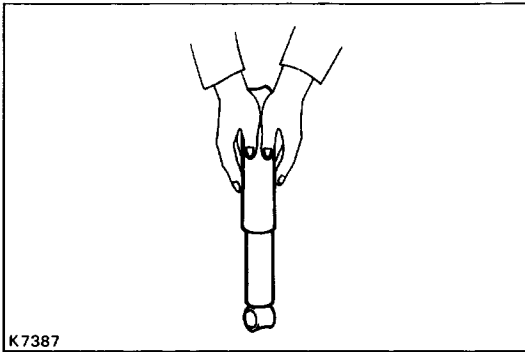

## INSPECTION OF SHOCK ABSORBER

### 1. INSPECT SHOCK ABSORBER

Compress and extend the shock absorber and check that there is no abnormal resistance or unusual operation sounds.

If there is any abnormality, replace the shock absorber with new one.

**NOTICE:** When discarding the shock absorber, use the following procedure.

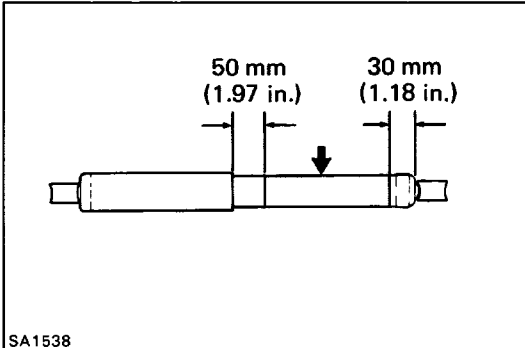

## DISPOSAL OF SHOCK ABSORBER

### 1. FULLY EXTEND SHOCK ABSORBER

### 2. DRILL HOLE TO REMOVE GAS FROM CYLINDER

Using a drill, make a hole in the cylinder as shown to remove the gas inside.

**CAUTION:** The gas coming out is harmless, but be careful of chips which may fly up when drilling.

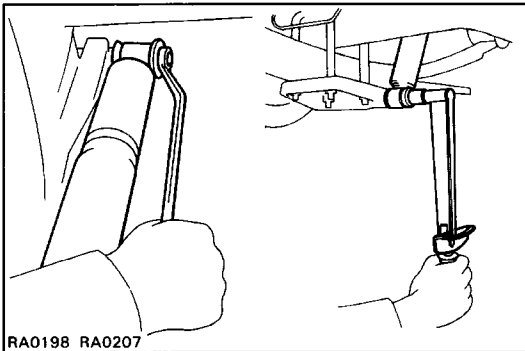

## INSTALLATION OF SHOCK ABSORBER

### INSTALL REAR SHOCK ABSORBER

(a) Connect the shock absorber to the frame with the bolt. Tighten the bolt.

**Torque:** 2WD 25 N-m (260 kgf-cm, 19 ft-lbf)

4WD 72 N-m (730 kgf-cm, 53 ft-lbf)

(b) Connect the shock absorber to the spring seat with the bolt. Tighten the bolt.

**Torque:** 2WD 25 N-m (260 kgf-cm, 19 ft-lbf)

4WD 72 N-m (730 kgf-cm, 53 ft-lbf)

# Leaf Spring COMPONENTS

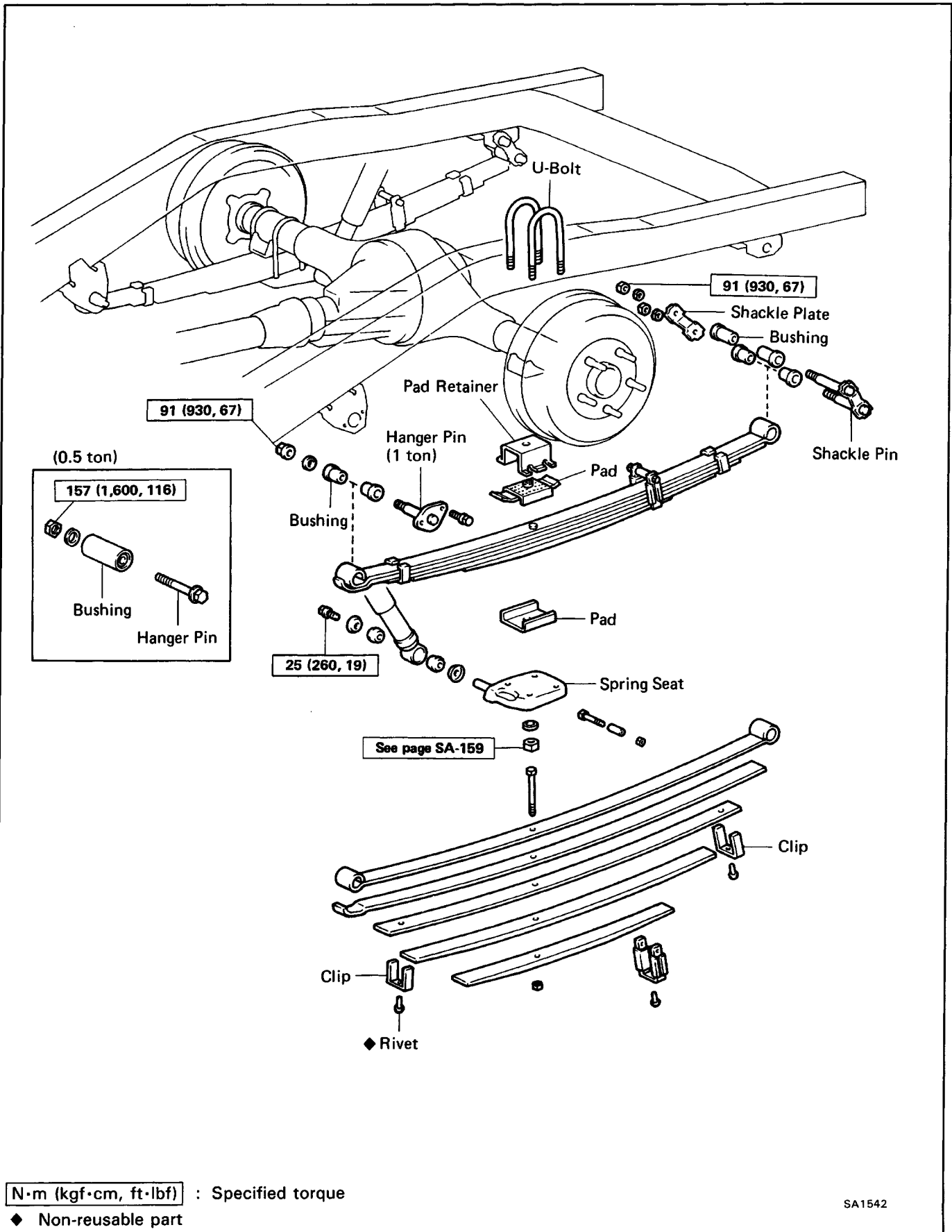

# COMPONENTS

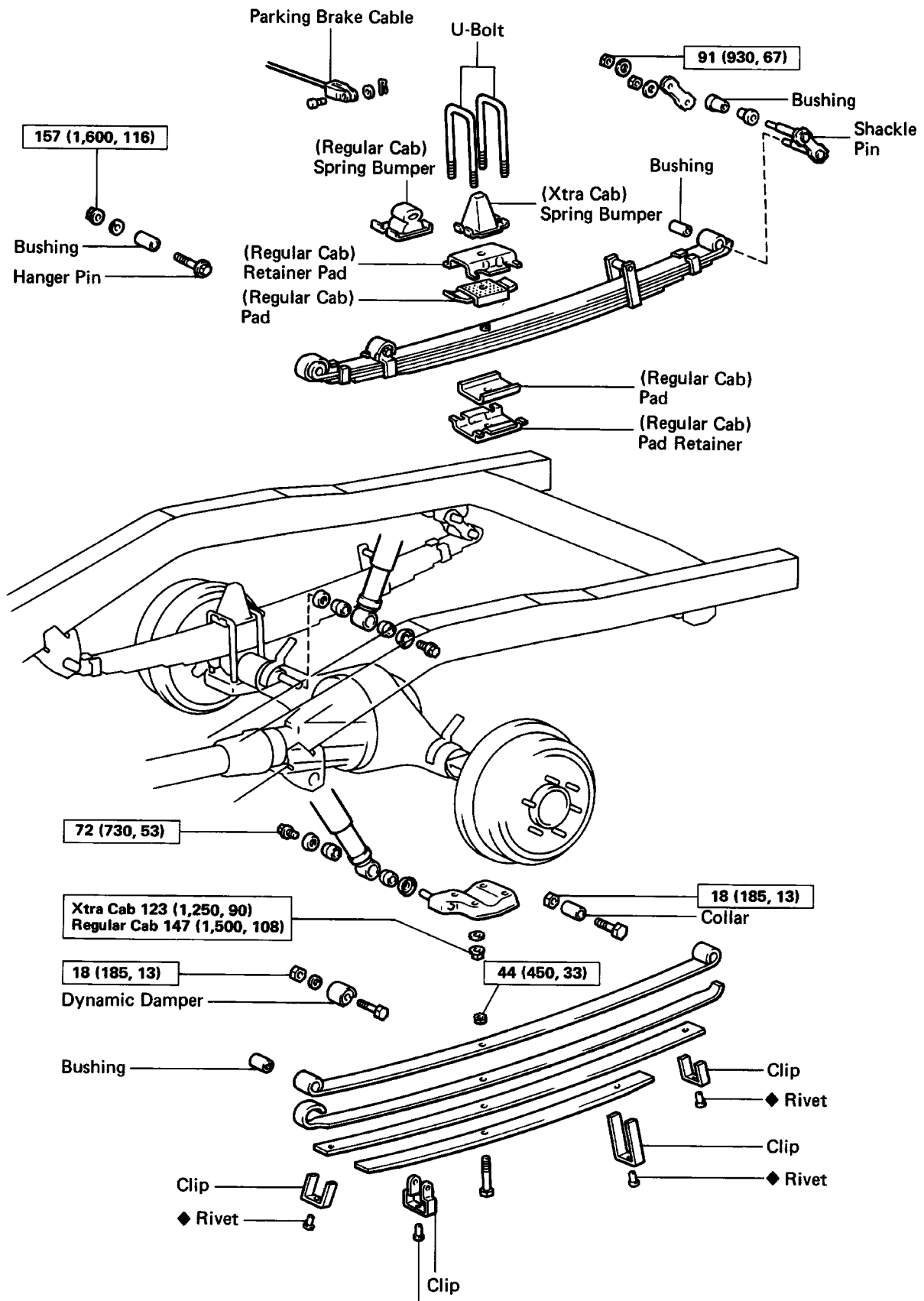

**N·m (kgf·cm, ft·lbf)** : Specified torque

◆ Non-reusable part



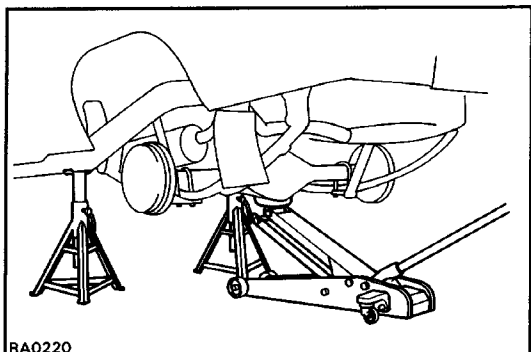

RA0220

## REMOVAL OF LEAF SPRING

### 1. JACK UP AND SUPPORT BODY

- (a) Jack up and support the body on the stands.
- (b) Lower the axle housing until the leaf spring tension is free, and keep it at this position.

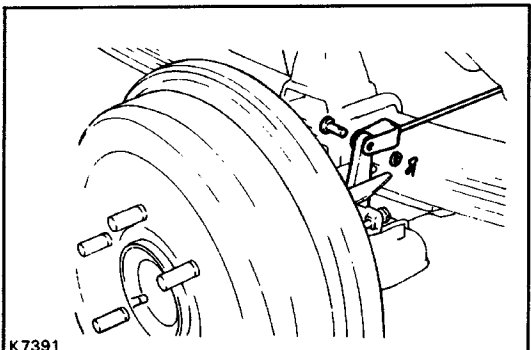

K7391

### 2. (4WD)

#### DISCONNECT PARKING CABLE

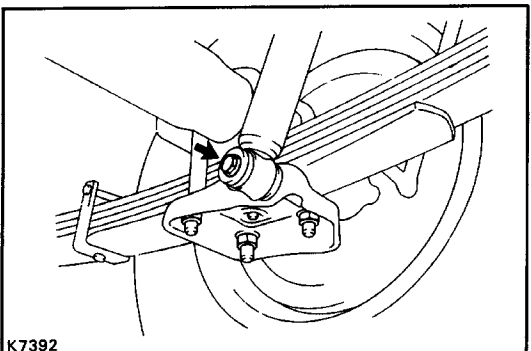

K7392

### 3. DISCONNECT SHOCK ABSORBER FROM SPRING SEAT

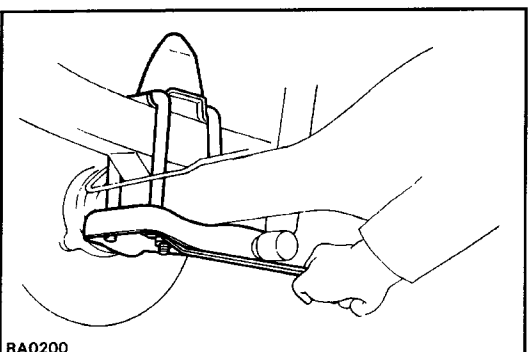

RA0200

### 4. REMOVE U-BOLTS

- (a) Remove the U-bolt mounting nuts.
- (b) Remove the spring seat, pads and pad retainer.
- (c) Remove the U-bolts.
- (d) (4WD)  
Remove the spring bumper.

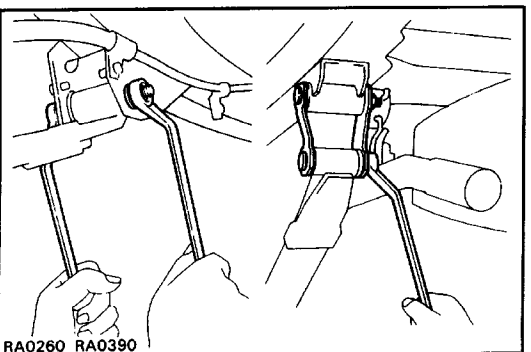

RA0260 RA0390

### 5. REMOVE LEAF SPRING

- (a) Remove the hanger pin bolt.
- (b) (1 ton and C&C )  
Remove the hanger pin lock bolt.
- (c) Disconnect the leaf from the bracket.
- (d) Remove the shackle pin mounting nuts.
- (e) Remove the shackle pin and plate and remove the leaf spring.

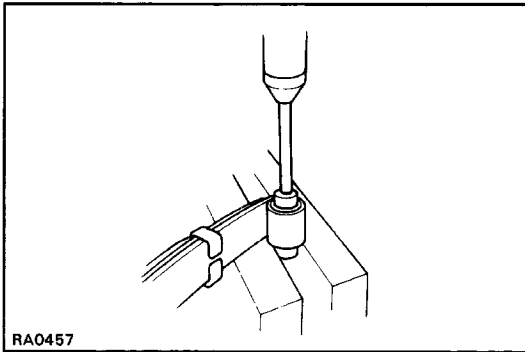

RA0457

## REPLACEMENT OF BUSHING

### REPLACE BUSHINGS WITH PRESS

Using a press and socket wrench, replace the eye bushings.

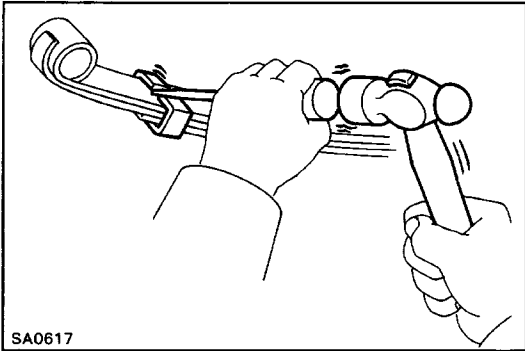

SA0617

## REPLACEMENT OF LEAF SPRING

### 1. BEND OPEN SPRING CLIP

Using a chisel, pry up the spring clip.

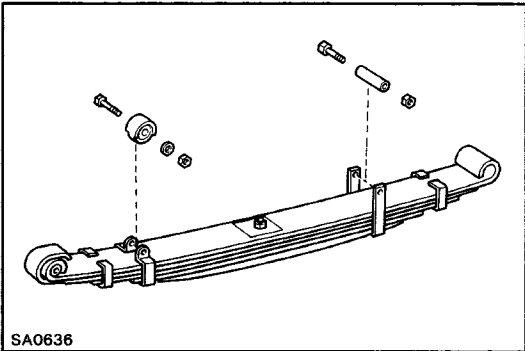

SA0636

### 2. REMOVE CLIP BOLT

Remove the clip bolt, collar and nut from the clip.

### 3. REMOVE DYNAMIC DAMPER

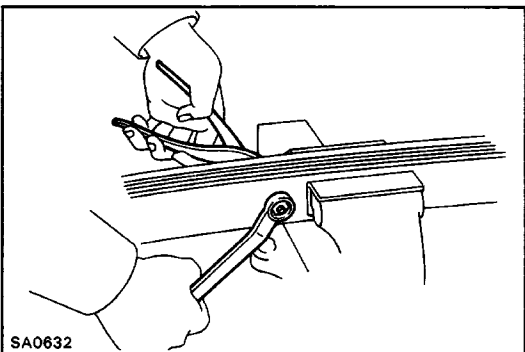

SA0632

### 4. REMOVE CENTER BOLT

Hold the spring near the center bolt in a vise and remove the center bolt.

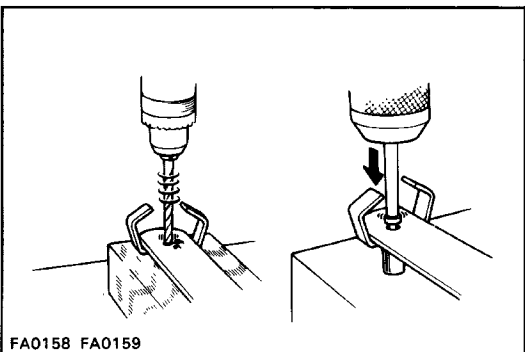

FA0158 FA0159

### 5. IF NECESSARY, REPLACE SPRING CLIP

(a) Drill off the head of the rivet, and drive it out.

(b) Install a new rivet into the holes of the spring leaf and clip. Then rivet with a press.

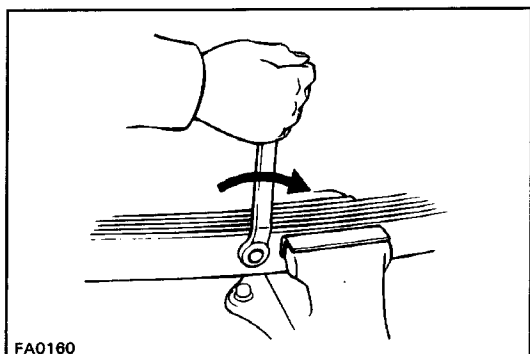

FA0160

## 6. INSTALL SPRING CENTER BOLT

- (a) Align the leaf holes and secure the leaves with a vise.
- (b) Install and tighten the spring center bolt.  
Torque: 44 N-m (450 kgf-cm, 33 ft-lbf)

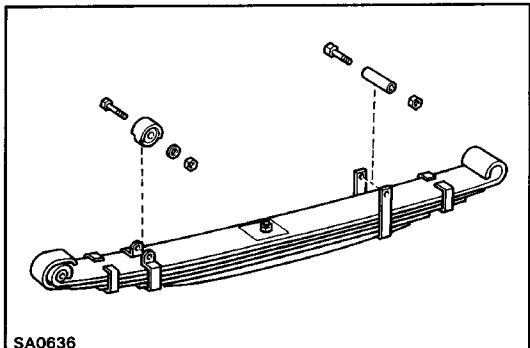

SA0636

## 7. INSTALL CLIP BOLT

- Position the collar and install the clip bolt and nut.  
Torque: 18 N-m (185 kgf-cm, 13 ft-lbf)

## 8. INSTALL DYNAMIC DAMPER

- Position the dynamic damper and install the bolt and nut.  
Torque: 18 N-m (185 kgf-cm, 13 ft-lbf)

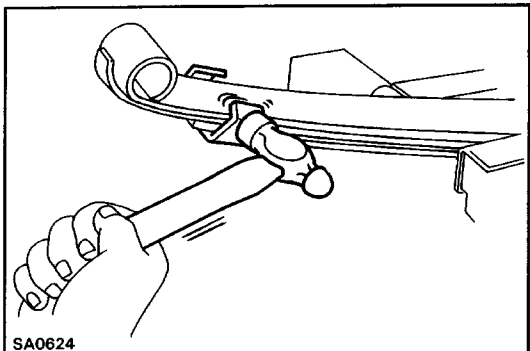

SA0624

## 9. BEND SPRING CLIP

- Using a hammer, bend the spring clip into position.

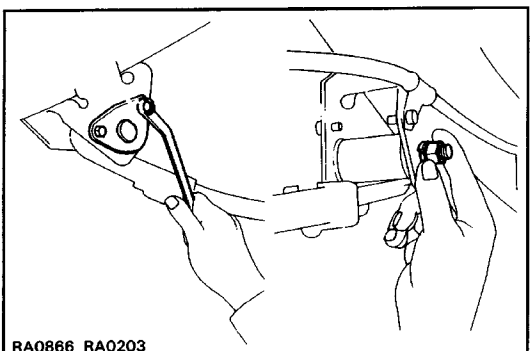

RA0866 RA0203

## INSTALLATION OF LEAF SPRING

### 1. INSTALL LEAF SPRING

- (a) Place the front end of leaf spring in the front bracket and install the hanger pin bolt.
- (b) (1 ton and C&C)  
Install and tighten the hanger pin lock bolt.  
Torque: 13 N-m (130 kgf-cm, 9 ft-lbf)
- (c) Finger tighten the hanger pin nut.
- (d) Place the rear end of leaf spring in the rear bracket, and install the shackle pin.
- (e) Install the plate and finger tighten the nuts.

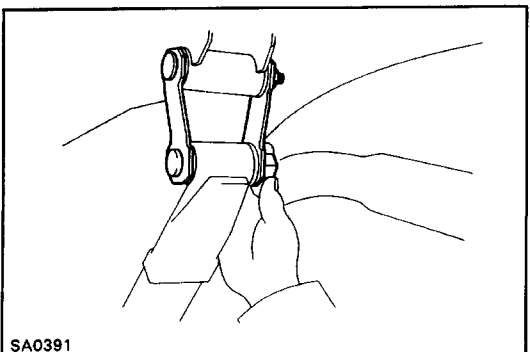

SA0391

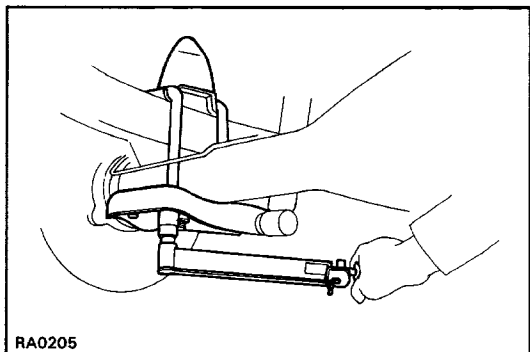

## 2. INSTALL U-BOLTS

(a) Install the pads and pad retainer on the leaf spring.

(b) (4WD)

Install the spring bumper.

M Install the spring seat, U-bolts, washers and nuts.

(d) Tighten the U-bolt mounting nuts.

**Torque:**

2W D 0.5 ton	147 N-m
	(1,500 kgf-cm, 108 ft-lbf)
1 ton, C&C	123 N-m
	(1,250 kgf-cm, 90 ft-lbf)

4WD Xtra cab 123 N-m

(1,250 kgf-cm, 90 ft-lbf )

Regular Cab 147 N-m

(1,500 kgf-cm, 108 ft-lbf)

**HINT:** Tighten the U-bolts so that the length of all the U-bolts under the spring seat are the same.

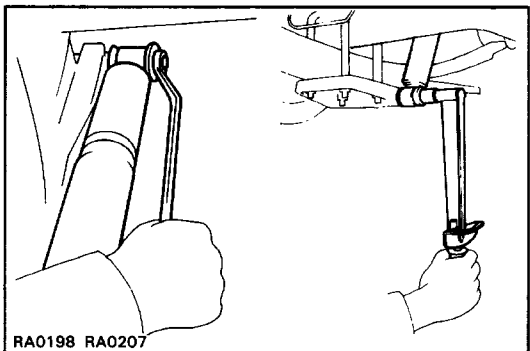
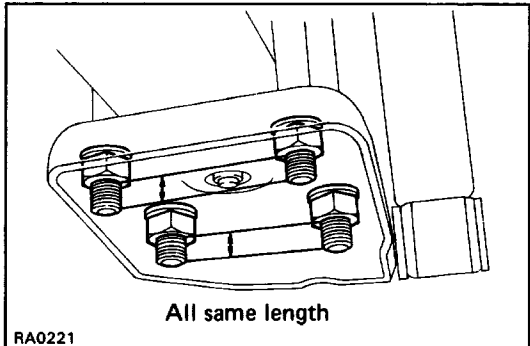

## 3. INSTALL REAR SHOCK ABSORBER

(a) Connect the shock absorber to the frame with the bolt. Tighten the bolt.

**Torque:** 2WD 25 N-m (260 kgf-cm, 19 ft-lbf)

4WD 72 N-m (730 kgf-cm, 53 ft-lbf)

(b) Connect the shock absorber to the spring seat with the bolt. Tighten the bolt.

**Torque:** 2WD 25 N-m (260 kgf-cm, 19 ft-lbf)

4WD 72 N-m (730 kgf-cm, 53 ft-lbf)

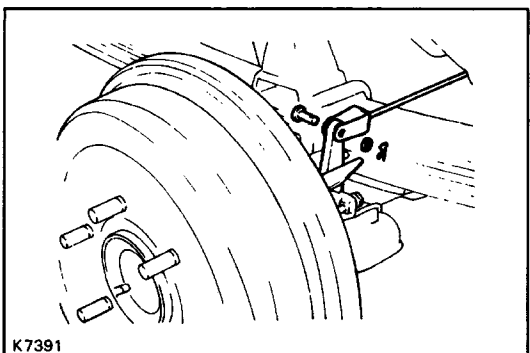

## 4. (4WD)

### CONNECT PARKING BRAKE CABLE

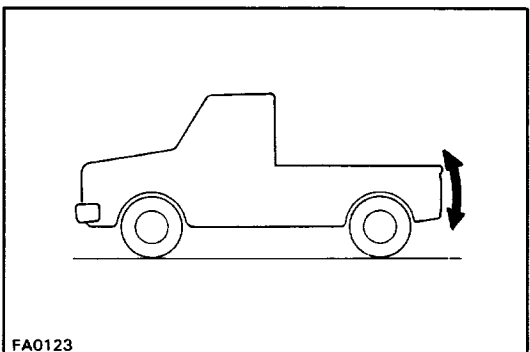

## 5. STABILIZE SUSPENSION

(a) Install the wheel.

(b) Remove the stands and bounce the vehicle up and down to stabilize the suspension.

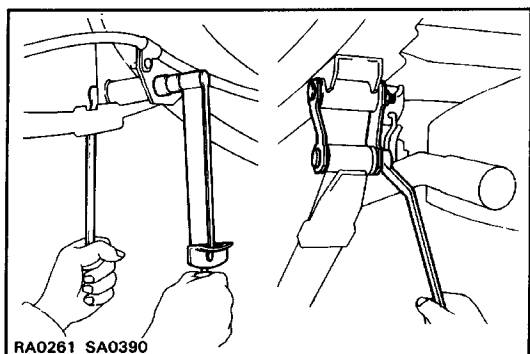

## 6. TIGHTEN HANGER PIN AND SHACKLE PIN

Tighten the hanger pin nut.

**Torque: 0.5 ton**

**157 N-m (1,600 kgf-cm, 116 ft-lbf )**

**1 ton and C&C**

**91 N-m (930 kgf -cm, 67 ft-lbf)**

Tighten the shackle nuts.

**Torque: 91 N-m (930 kgf-cm, 67 ft-lbf )**

## Stabilizer Bar

(See page [SA-153](#))

### REMOVAL OF STABILIZER BAR

#### 1. JACK UP AND SUPPORT VEHICLE

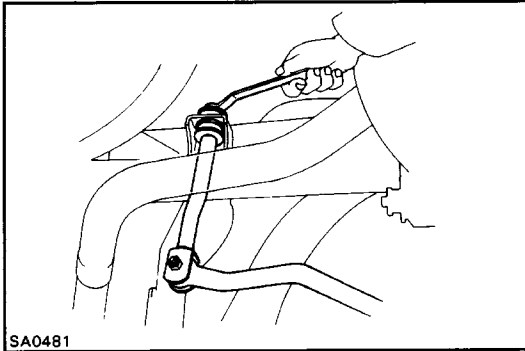

#### 2. DISCONNECT STABILIZER BAR LINK FROM BODY

- (a) Disconnect the stabilizer bar link from the body.
- (b) Remove the retainers and cushion from the link.

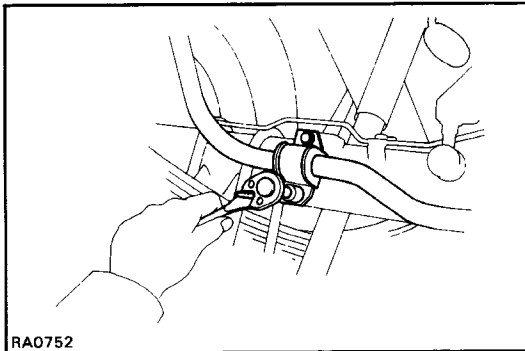

#### 3. REMOVE STABILIZER BAR

- (a) Remove the stabilizer bar bracket with cushion from the rear axle housing.
- (b) Remove the stabilizer bar.

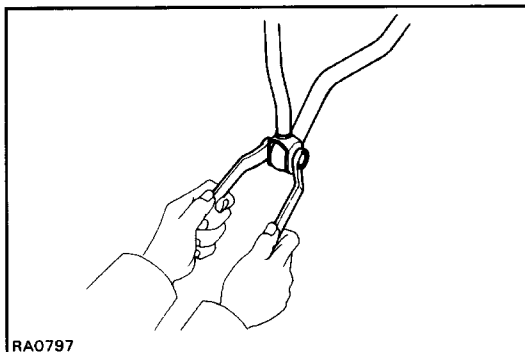

#### 4. REMOVE STABILIZER BAR LINK

- (a) Remove the retainers and cushion from the link.
- (b) Remove the bolt and nut.
- (c) Remove the stabilizer bar link from the stabilizer bar.

### INSTALLATION OF STABILIZER BAR

(See page [SA-153](#))

#### 1. INSTALL STABILIZER BAR LINK

- (a) Install the retainers and cushion to the link.
- (b) Connect the link to the stabilizer bar and torque the bolt and nut.

**Torque: 36 N-m (365 kgf-cm, 26 ft-lbf)**

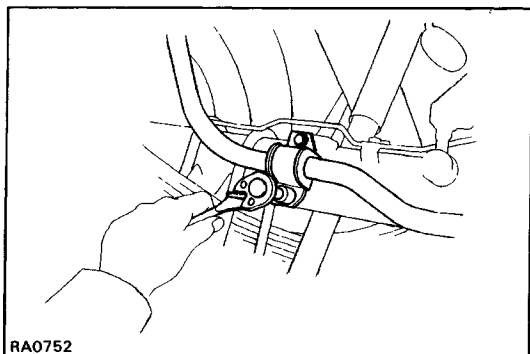

## 2. INSTALL STABILIZER BAR

- (a) Place the stabilizer bar to the rear axle housing.
- (b) Install the cushion and bracket.

**Torque: 13 N-m (130 kgf-cm, 9 ft-lbf)**

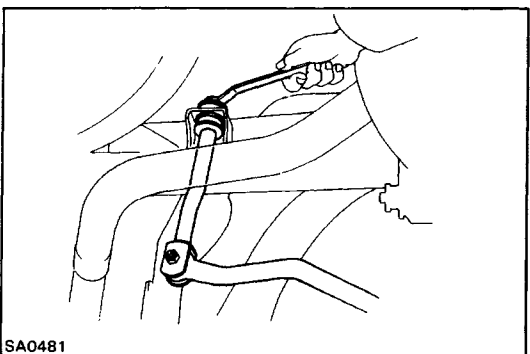

## 3. CONNECT STABILIZER BAR LINK

- (a) Position the link to the body.
- (b) Install the retainers and cushion to the link.
- (e) Install a new nut.

**Torque: 17 N-m (170 kgf-cm, 12 ft-lbf)**

## 4. LOWER VEHICLE

# BRAKE SYSTEM



## PRECAUTIONS

1. Care must be taken to replace each part properly as it could affect the performance of the brake system and result in a driving hazard. Replace the parts with parts of the same part number or equivalent.
2. It is very important to keep parts and the area clean when repairing the brake system.

## TROUBLESHOOTING

Problem	Possible cause	Remedy	Page
Low or spongy pedal	Linings worn Brake pads worn Leak in brake system Master cylinder faulty Air in brake system Wheel cylinder faulty Brake cylinder faulty Piston seals worn or damaged Rear brake automatic adjuster faulty	Replace brake shoes Replace pads Repair leak Repair or replace master cylinder Bleed brake system Repair wheel cylinder Repair cylinder Repair brake cylinder Repair or replace adjuster	<a href="#">BR-40</a> , 47 55 <a href="#">BR-18</a> , 26 33 <a href="#">BR-10</a> <a href="#">BR-8</a> <a href="#">BR-40</a> , 47 55 <a href="#">BR-18</a> , 26 33 <a href="#">BR-18</a> , 26 33 <a href="#">BR-40</a> , 47 55
Brakes drag	Parking brake out of adjustment Binding parking brake wire Booster push rod out of adjustment Tension or return spring faulty Brake line restricted Lining cracked or distorted Pad cracked or distorted Wheel cylinder or caliper piston sticking Adjuster broken Master cylinder faulty	Adjust parking brake Repair as necessary Adjust push rod Replace spring Repair as necessary Replace shoe Replace pad Repair as necessary Replace adjuster Repair or replace master cylinder	<a href="#">BR-9</a> <a href="#">BR-17</a> <a href="#">BR-40</a> , 47 55 <a href="#">BR-40</a> , 47 55 <a href="#">BR-18</a> , 26 33 <a href="#">BR-18</a> , 26 33 <a href="#">BR-10</a>
Brakes pull	Tires improperly inflated Oil or grease on shoes or pads Brake shoes distorted, linings worn or glazed Brake pads distorted, worn or glazed Drum or disc out of round  Tension or return spring faulty Wheel cylinder faulty Brake cylinder faulty Piston frozen in brake cylinder Brake pad sticking	Inflate tires to proper pressure Check for cause. Replace shoes or pads Replace brake shoes Replace pads Replace drum or disc  Replace spring Repair wheel cylinder Repair cylinder Repair cylinder Replace pads	  <a href="#">BR-40</a> , 47 55 <a href="#">BR-18</a> , 26 33 <a href="#">BR-18</a> , 26 33,40 47, 55 <a href="#">BR-40</a> , 47 55 <a href="#">BR-18</a> , 26 33 <a href="#">BR-18</a> , 26 33 <a href="#">BR-18</a> , 26 33

## TROUBLESHOOTING (Cont'd)

Problem	Possible cause	Remedy	Page
Hard pedal but brakes inefficient	Oil or grease on shoes or pads  Brake shoes distorted, linings worn or glazed, drums worn Brake pads distorted, worn or glazed  Piston frozen in brake cylinder  Brake booster faulty Vacuum leaks Brake line restricted	Check for cause. Replace shoes or pads Replace brake shoes Replace pads  Repair cylinder  Repair booster Repair as necessary Repair as necessary	BR-40, 47 55 BR-18, 26 33 BR-18, 26 33 BR-16
Snapping or clicking noise when brakes are applied	(Drum brake) Brake shoes binding at backing plate ledges Backing plate ledges worn  Loose or missing shoe hold-down spring  Loose set bolt at backing plate  (Disc brake) Loose or missing pad support plate  Loose installation bolt	Lubricate  Replace and lubricate ledges  Replace shoe hold-down spring  Tighten  Replace pad support plate  Tighten	BR-40, 47 55 BR-40, 47 55 BR-40, 47 55 BR-40, 47 55  BR-18, 26 33 BR-18, 26 33
Scraping or grinding noise when brakes are applied	Worn brake linings or pads  Caliper to wheel or rotor interference  Dust cover to rotor or backing plate to drum interference  Other brake system components faulty Tires rubbing against chassis and/or body	Replace or refinish drums or rotors if heavily scored  Replace as required  Correct or replace  Repair or replace as necessary Repair as necessary	BR-18, 26 33,40 47, 55 BR-18, 26 33 BR-18, 26 33,40 47, 55

## TROUBLESHOOTING (Cont'd)

Problem	Possible cause	Remedy	Page
<p>Squeaking, squealing, groaning or chattering noise when brakes are applied</p> <p>HINT: Brake friction materials inherently generate noise and heat in order to dissipate energy. As a result, occasional squeal is normal and is aggravated by severe environmental conditions such as cold, heat, wetness, snow, salt, mud, etc. This occasional squeal is not a functional problem and does not indicate any loss of brake effectiveness</p>	<p>Brake drums and linings, rotors and pads worn or scored</p> <p>Dirty, greased, contaminated or glazed linings or pads</p> <p>Improper linings or pads using</p> <p>Maladjustment of brake pedal or booster push rod</p> <p>(Disc brake)</p> <p>Missing or damaged brake pad anti-squeal shim</p> <p>Pad wear and pad wear indicator making contact with the rotor</p> <p>Burred or rusted calipers</p> <p>(Drum brake)</p> <p>Weak damaged or incorrect shoe hold-down springs, loose or damaged shoe hold-down spring pins and springs and grooved backing plate ledges</p>	<p>Inspect, repair or replace</p> <p>Clean or replace</p> <p>Inspect for correct usage or replace</p> <p>Inspect and adjust</p> <p>Replace</p> <p>Replace</p> <p>Clean or deburr</p> <p>Inspect, repair or replace</p>	<p>BR-18, 26 33,40 47, 55 BR-18, 26 33,40 47, 55</p> <p>BR-6, 17</p> <p>BR-1 8, 26 33 BR-18, 26 33 BR-18, 26</p> <p>33 BR-40, 47 55</p>
<p>Squealing and squeaking noise when brakes are not applied</p>	<p>Mal-adjustment of brake pedal or booster push rod</p> <p>Poor return of brake booster or master cylinder or brake cylinder</p> <p>(Disc brake)</p> <p>Rusted or stuck piston</p> <p>Improper positioning of pad in caliper</p> <p>Rotor rubbing against caliper housing</p> <p>Improper installation of disc brake pad support plate</p> <p>Pad wear and pad wear indicator making contact with the rotor</p> <p>(Drum brake)</p> <p>Weak, damaged or incorrect shoe hold-down springs</p> <p>Grooved backing plate ledges</p> <p>Bent or warped backing plate causing interference with drum</p> <p>Improper machining of drum causing interference with backing plate or shoe</p> <p>Other brake system components:</p> <p>Loose or extra parts in brakes</p> <p>Rear drum adjustment too tight causing lining to glaze</p> <p>Worn, damaged or insufficiently lubricated wheel bearings</p>	<p>Inspect and adjust</p> <p>Inspect, repair or replace</p> <p>Inspect and lubricate as necessary</p> <p>Reinstall correctly</p> <p>Inspect and replace</p> <p>Reinstall correctly</p> <p>Replace</p> <p>Replace</p> <p>Repair or replace</p> <p>Repair or replace</p> <p>Replace drum</p> <p>Inspect, repair or replace as necessary</p>	<p>BR-6, 17 BR-10, 16 18,26 33,40 47, 55</p> <p>BR-18, 26 33</p> <p>BR-18, 2 33 BR-18, 26 33</p> <p>BR-40, 47 55 BR-40, 47 55 BR-40, 47 55</p> <p>BR-40, 47 55</p> <p>BR-40, 47 55</p>

## TROUBLESHOOTING (Cont'd)

Problem	Possible cause	Remedy	Page
Groaning, clicking or rattling noise when brakes are not applied	Stones or foreign material trapped inside wheel covers Loose wheel nuts	Remove foreign material  Tighten to correct torque Replace if stud holes are elongated Inspect and adjust	
	Mal-adjustment of brake pedal or booster push rod		BR-6, 17
	Worn, damaged or dry wheel bearings (Disc brake)	Inspect and lubricate or replace	
	Loose or missing anti-rattle spring or pad support plate or crimping on outer pad	Inspect, repair or replace	BR-18, 26
	Failure of shim	Inspect, replace if necessary	33
			BR-18, 26
			33
			BR-18, 26
	Wear on slide bushing	Inspect, replace if necessary	33
	Loose installation bolt	Inspect, tighten if necessary	BR-18, 26 33
Poor return of piston	Inspect, repair or replace	BR-18, 26 33	
(Drum brake)			
Loose or extra parts	Inspect and repair	BR-40, 47 55	

## CHECKS AND ADJUSTMENTS

### CHECK AND ADJUSTMENT OF BRAKE PEDAL

#### 1. CHECK THAT PEDAL HEIGHT IS CORRECT, AS SHOWN PEDAL HEIGHT FROM ASPHALT SHEET:

2WD 148 MM (5.83 IN.)

4WD 145 MM (5.71 IN.)

#### 2. IF NECESSARY, ADJUST PEDAL HEIGHT

- (a) Disconnect the connector from the stop light switch.
- (b) Loosen the stop light switch lock nut and remove the stop light switch.
- (c) Loosen the push rod lock nut.
- (d) Adjust the pedal height by turning the pedal push rod.

- (e) Tighten the push rod lock nut.

**Torque: 25 N-m (260 kgf-cm, 19 ft-lbf)**

- (f) Install the stop light switch and turn it until it lightly contacts the pedal stopper.

- (g) Return the stop light switch one turn.

- (f) Check the clearance

- (A) between stop light switch and pedal.

**Clearance: 0.5 – 2.4mm (0.02 – 0.09 in.)**

- (i) Tighten the stop light switch lock nut.

- (j) Check that the stop light come on when the brake pedal is depressed, and go off when the brake pedal is released.

- (k) After adjusting the pedal height, check the pedal free play.

HINT: If clearance

- (A) between the stop light switch and the pedal stopper has been adjusted correctly, the pedal freeplay will meet the specifications.

#### 3. CHECK THAT PEDAL FREEPLAY IS CORRECT, AS SHOWN

- (a) Stop the engine and depress the brake pedal several times until there is no more vacuum left in the booster.

- (b) (Single booster)

Push in the pedal until the beginning of resistance is felt. Measure the distance, as shown.

(Tandem booster)

Push in the pedal by hand until the beginning of the second resistance is felt, measure the distance, as shown.

**Pedal freeplay: 3 – 6mm (0.12 – 0.24 in.)**

(Tandem booster)

HINT: The freeplay to the first resistance is due to the play between the clevis and pin. And it is 1 – 3mm (0.04 – 0.12 in.) on the pedal.

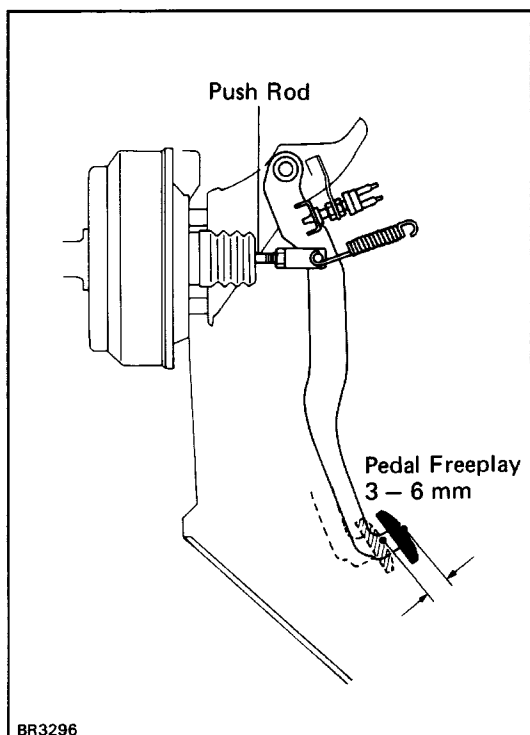
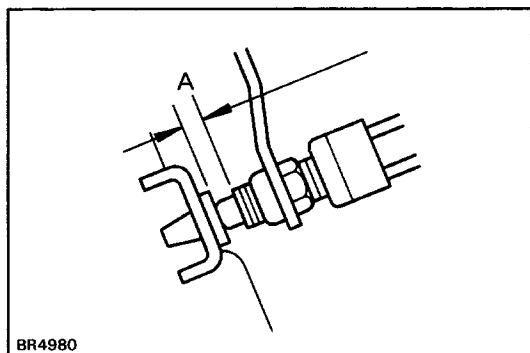
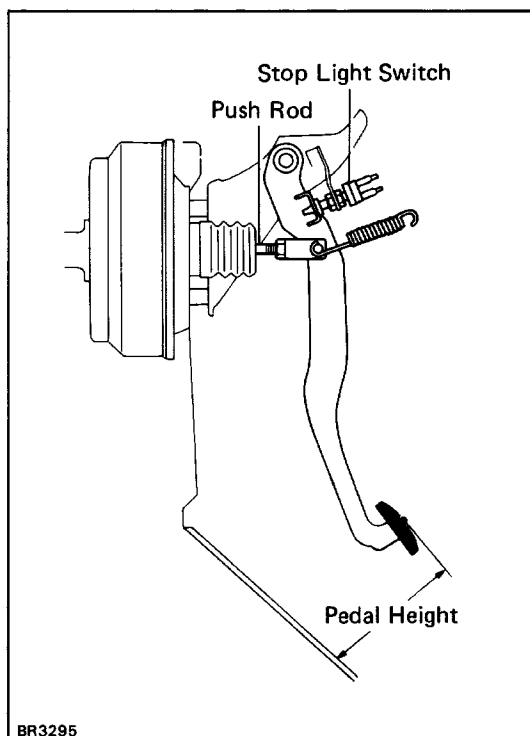

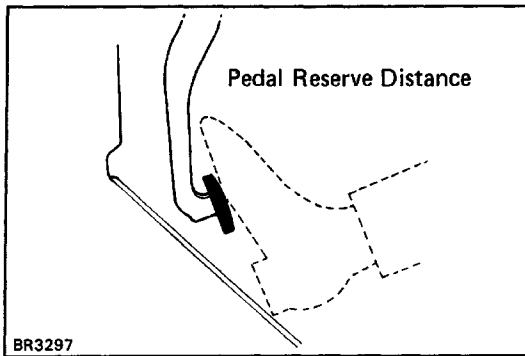

#### 4. CHECK THAT PEDAL RESERVE DISTANCE IS CORRECT, AS SHOWN

Release the parking brake.

With engine running, depress the pedal and measure the pedal reserve distance, as shown.

**Pedal reserve distance from asphalt sheet at 490 N (50 kgf, 110.2 lbf):**

**(2WD)**

**22R-E Engine                      More than 70 mm (2.76 in.)**

**3VZ-E Engine**

**1 ton                                      More than 75 mm (2.95 in.)**

**1/2 ton                                    More than 65 mm (2.56 in.)**

**C&C**

**SRW                                      More than 75 mm (2.95 in.)**

**DRW                                      More than 55 mm (2.17 in.)**

**(4WD)**

**More than 65 mm (2.56 in.)**

If incorrect, troubleshoot the brake system.

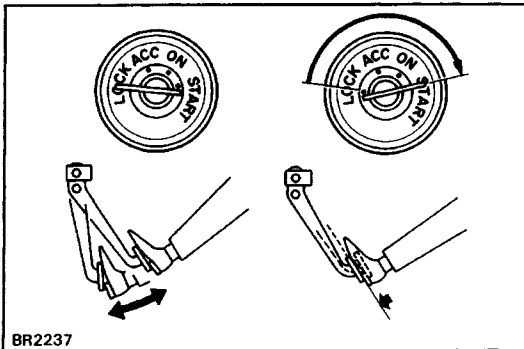

#### OPERATIONAL TEST OF BRAKE BOOSTER

**HINT:** If available, use a brake booster tester to check the booster operating condition.

##### 1. OPERATING CHECK

- (a) Depress the brake pedal several times with the engine off, and check that there is no change in the pedal reserve distance.
- (b) Depress the brake pedal and start engine. If the pedal goes down slightly, operation is normal.

##### 2. AIR TIGHTNESS CHECK

- (a) Start the engine and stop it after one or two minutes. Depress the brake pedal several times slowly. If the pedal goes down deepest the first time, but gradually rises after the second or third time, the booster is air tight.
- (b) Depress the brake pedal while the engine is running, and stop it with the pedal depressed. If there is no change in pedal reserve travel after holding the pedal for thirty seconds, the booster is air tight.

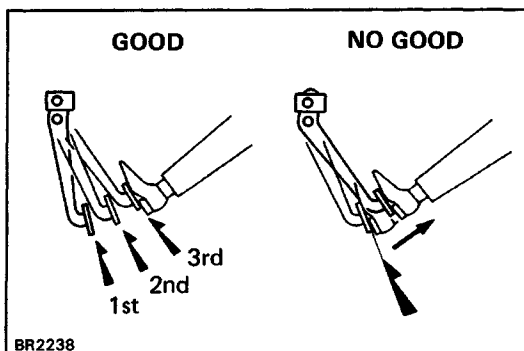

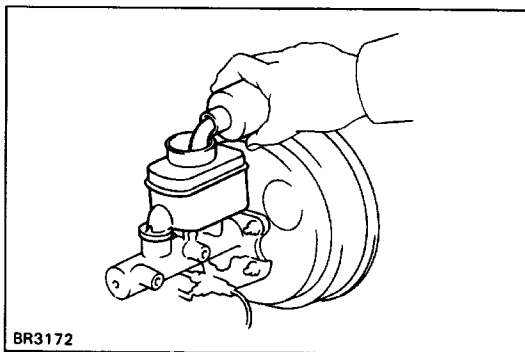

BR3172

## BLEEDING OF BRAKE SYSTEM

**HINT:** If any work is done on the brake system or if air is suspected in the brake lines, bleed the system of air.

**NOTICE:** Do not let brake fluid remain on a painted surface. Wash it off immediately.

### 1. FILL BRAKE RESERVOIR WITH BRAKE FLUID

Check the fluid level in the reservoir after bleeding each wheel. Add fluid, if necessary.

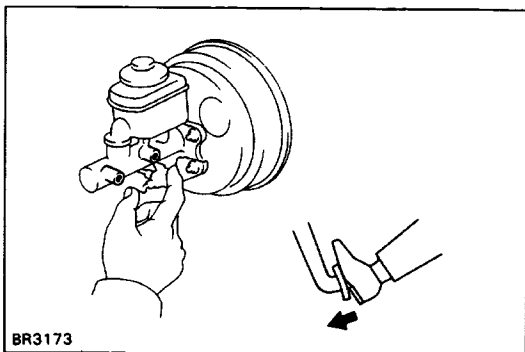

BR3173

### 2. BLEED MASTER CYLINDER

**HINT:** If the master cylinder was disassembled or if the reservoir tank becomes empty, bleed the air from the master cylinder.

(a) Disconnect the brake tubes from the master cylinder.

(b) Slowly depress the brake pedal and hold it.

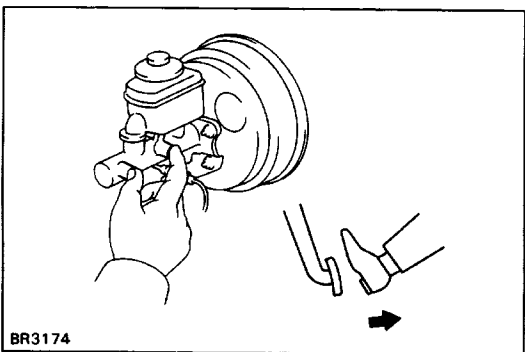

BR3174

(c) Block off the outlet plug with your finger, and release the brake pedal.

(d) Repeat

(b) and

(c) three or four times.

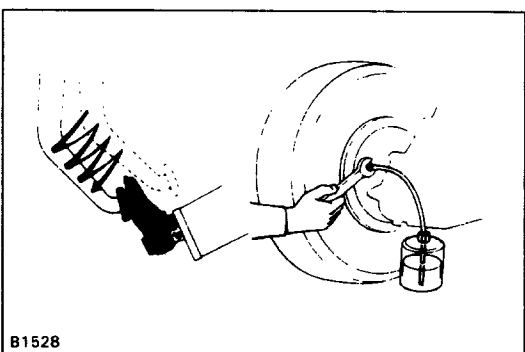

B1528

### 3. CONNECT VINYL TUBE TO WHEEL CYLINDER BLEEDER PLUG

Insert other end of the tube in a half-full container of brake fluid.

**HINT:** Begin air bleeding from the wheel cylinder with the longest hydraulic line.

### 4. BLEED BRAKE LINE

(a) Slowly depress the brake pedal several times.

(b) While an assistant depresses the pedal, loosen the bleeder plug until fluid starts to run out. Then close the bleeder plug.

(c) Repeat this procedure until there are no more air bubbles in the fluid.

**Bleeder plug tightening torque:**

11 N-m (110 kgf-cm, 8 ft-lbf)

### 5. REPEAT PROCEDURE FOR EACH WHEEL

### 6. BLEED LSP & BV

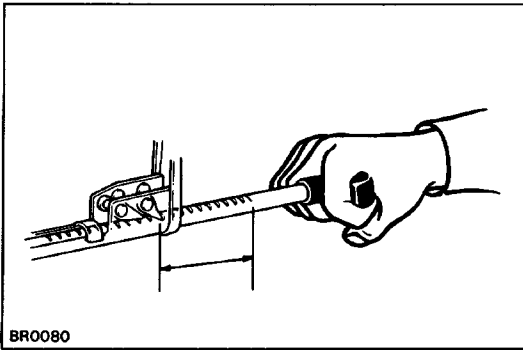

## CHECK AND ADJUSTMENT OF PARKING BRAKE

### 1. CHECK THAT PARKING BRAKE LEVER TRAVEL IS CORRECT

Pull the parking brake lever all the way up, and count the number of clicks.

**Parking brake lever travel at 196 N (20 kgf, 44.1 lbf)**

**2WD 1/2 ton 12 – 18 clicks**

**1 ton 11 – 17 clicks**

**4WD 11 – 17 clicks**

### 2. IF NECESSARY, ADJUST PARKING BRAKE

**HINT:** Before adjusting the parking brake, make sure that the rear brake shoe clearance has been adjusted.

(2WD)

- (a) Tighten the adjusting nut until the travel is correct. Then tighten the lock nut.
- (b) After adjusting the parking brake, confirm that the rear brakes are not dragging.

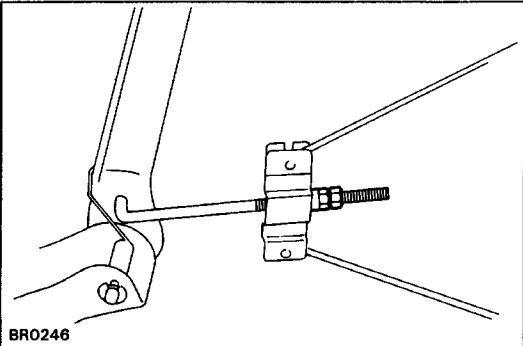

(4WD)

- (a) Tighten one of the adjusting nuts of the intermediate lever while loosening the other one until the travel is correct. Tighten the two adjusting nuts.
- (b) After adjusting the parking brake, confirm that the bellcrank stopper screw comes in contact with the backing plate.

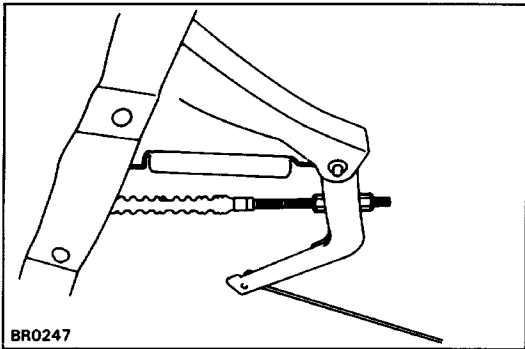



# MASTER CYLINDER

## REMOVAL OF MASTER CYLINDER

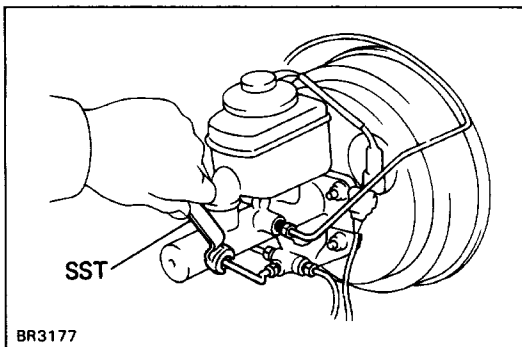
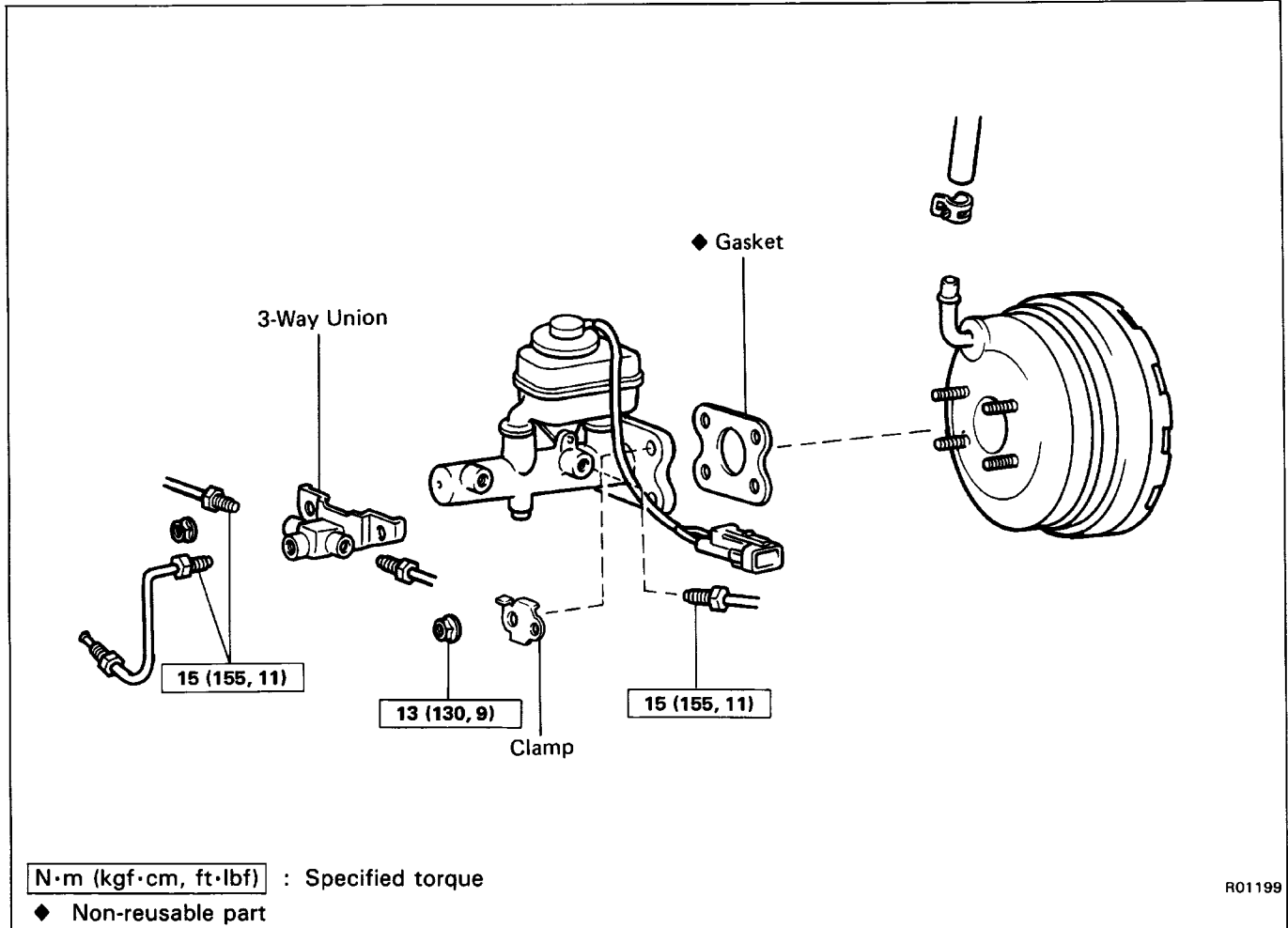

1. DISCONNECT LEVEL WARNING SWITCH CONNECTOR
2. DRAW OUT FLUID WITH SYRINGE

NOTICE: Do not let brake fluid remain on a painted surface. Wash it off immediately.

3. DISCONNECT BRAKE TUBES

Using SST, disconnect the brake tubes from the master cylinder.

SST 09751-36011

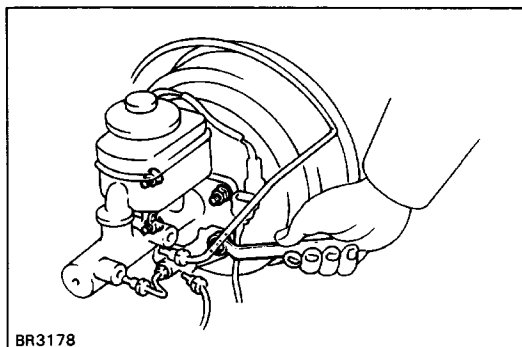

4. REMOVE MASTER CYLINDER

- (a) Remove the four nuts and 3-way union.
- (b) Remove the clamp.
- (c) Remove the master cylinder and gasket from the brake booster.

## COMPONENTS

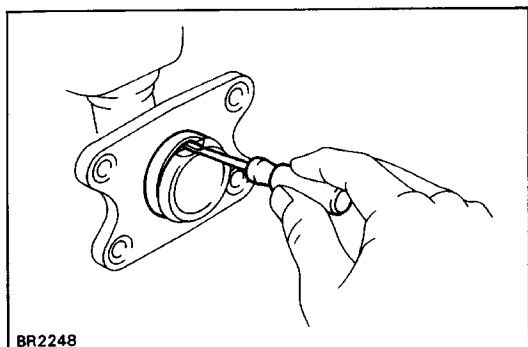
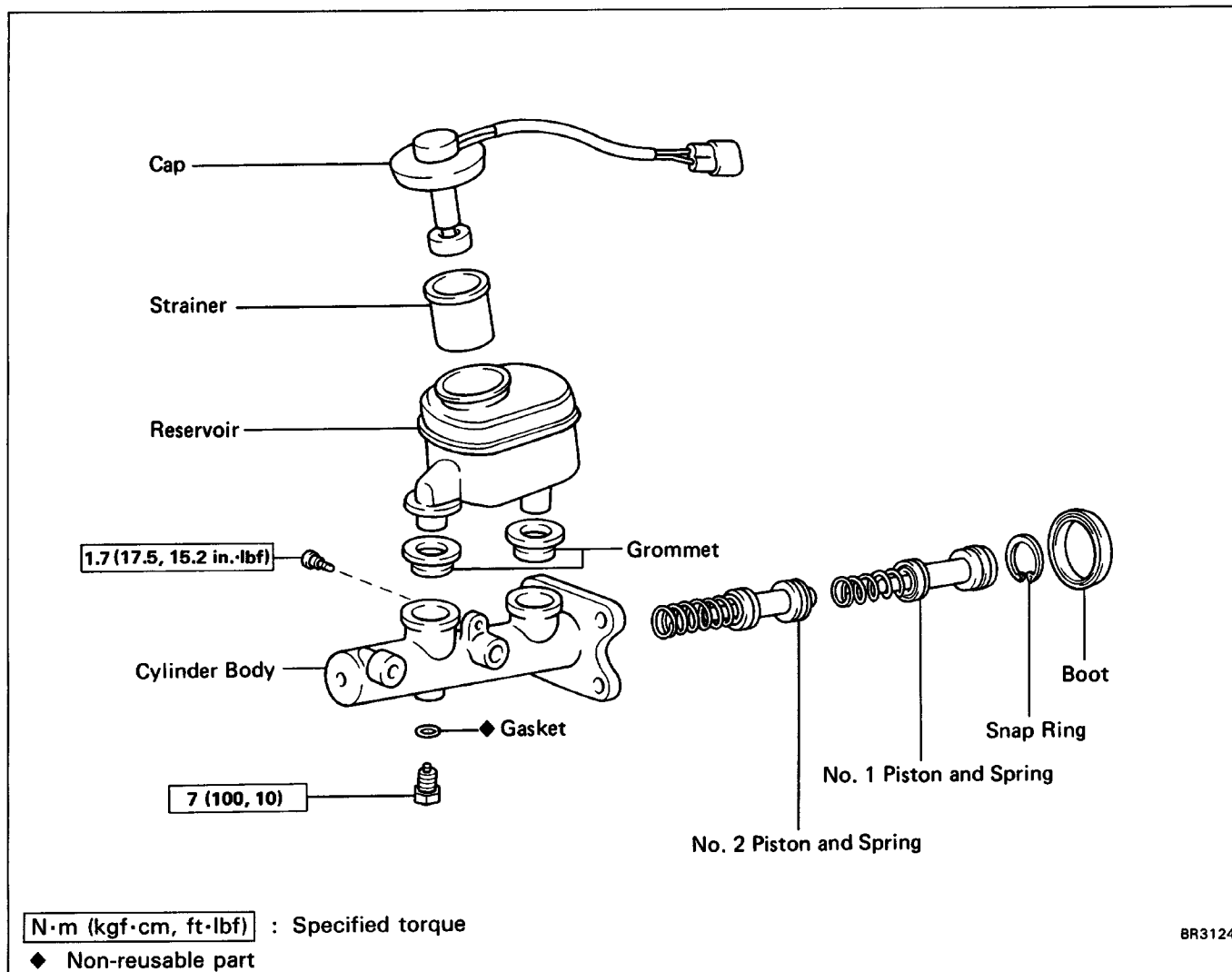

### DISASSEMBLY OF MASTER CYLINDER

#### 1. REMOVE MASTER CYLINDER BOOT

Using a screwdriver, remove the master cylinder boot.

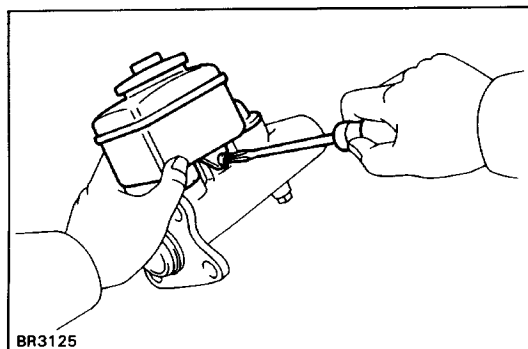

#### 2. REMOVE RESERVOIR

- Remove the set screw and pull out the reservoir.
- Remove the cap and strainer from the reservoir.

#### 3. REMOVE TWO GROMMETS

#### 4. PLACE CYLINDER IN VISE

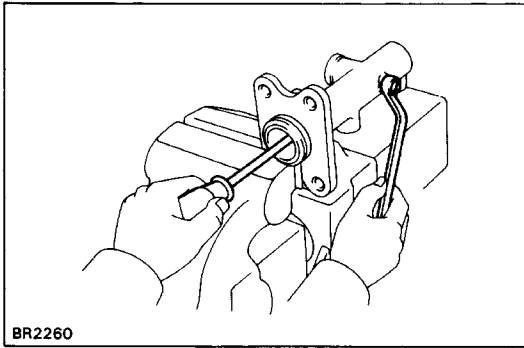

### 5. REMOVE PISTON STOPPER BOLT

Using a screwdriver, push the pistons in all the way and remove the piston stopper bolt and gasket.  
**HINT:** Tape the screwdriver tip before use.

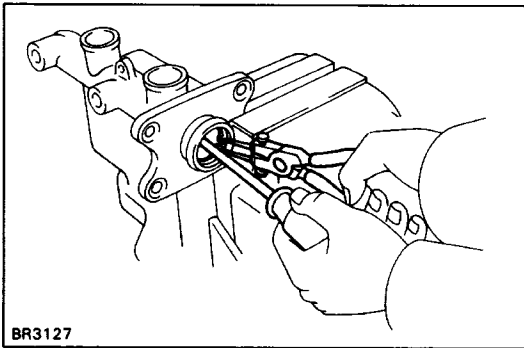

### 6. REMOVE TWO PISTONS AND SPRINGS

- (a) Push in the piston with a screwdriver and remove the snap ring with snap ring pliers.
- (b) Remove the No. 1 piston and spring by hand, pulling straight out, not at an angle.

**NOTICE:** If pulled out at an angle, there is possibility of damaging the cylinder bore.

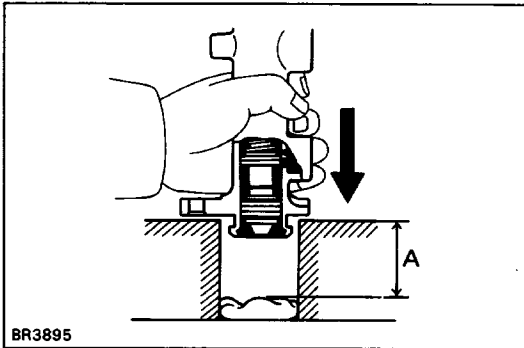

- (c) Place a rag and two wooden blocks on the work table, and lightly tap the cylinder flange against the block edges until the No.2 piston drops out of cylinder.

**HINT:** Make sure the distance

- (A) from the rag to the top of the blocks is at least 100 mm (3.94 in.).

## INSPECTION OF MASTER CYLINDER COMPONENTS

**HINT:** Clean the disassembled parts with compressed air.

### 1. INSPECT CYLINDER BORE FOR RUST OR SCORING

### 2. INSPECT CYLINDER FOR WEAR OR DAMAGE

If necessary, clean or replace the cylinder.

**ASSEMBLY OF MASTER CYLINDER**

(See page BR-11)

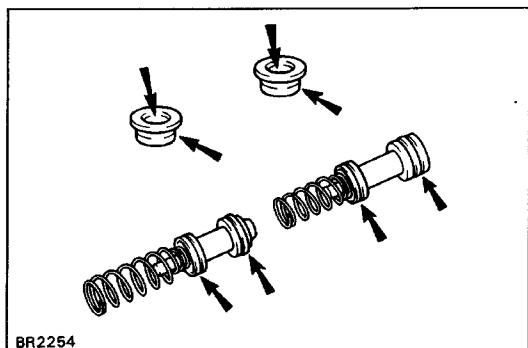
**1. APPLY LITHIUM SOAP BASE GLYCOL GREASE TO RUBBER PARTS INDICATED BY ARROWS**

BR2254

**2. INSTALL TWO SPRINGS AND PISTONS****NOTICE:** Be careful not to damage the rubber lips on the pistons.

- (a) Insert the two springs and pistons straight in, not at an angle.

**NOTICE:** If inserted at an angle, there is a possibility of damaging the cylinder bore.

- (b) Push in the piston with a screwdriver and install the snap ring with snap ring pliers.

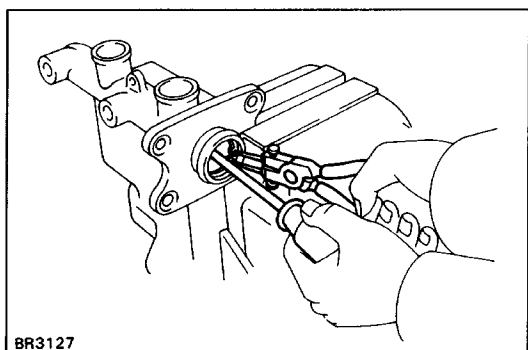
**HINT:** Tape the screwdriver tip before use.

BR3127

**3. INSTALL PISTON STOPPER BOLT**

Using a screwdriver, push the piston in all the way and install the piston stopper bolt over the gasket. Torque the bolt.

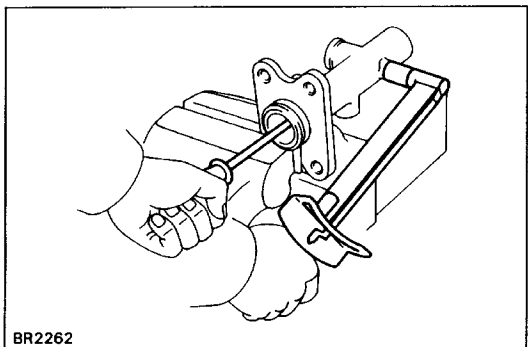
**Torque:** 10 N-m (100 kgf-cm, 7 ft-lbf)

BR2262

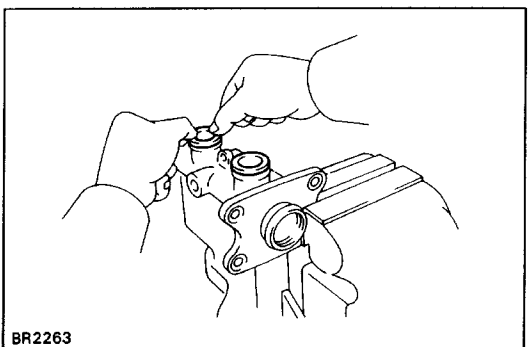
**4. INSTALL TWO GROMMETS**

BR2263

**5. INSTALL RESERVOIR**

- (a) Install the cap and strainer to the reservoir.  
 (b) Push the reservoir onto the cylinder.  
 (c) Install the set screw while pushing on the reservoir.

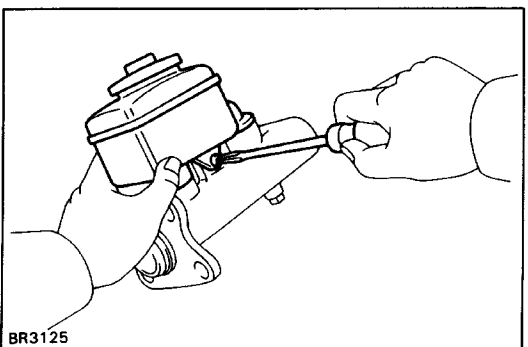
**Torque:** 1.7 N-m (17.5 kgf-cm, 15.2 in. -lbf)

BR3125

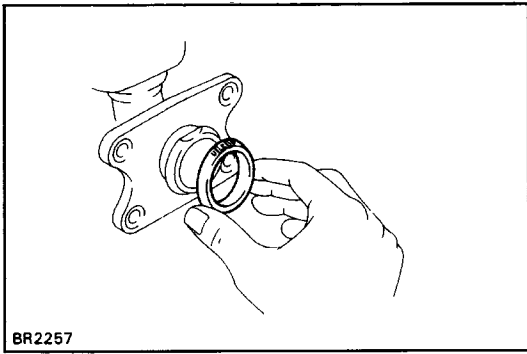

## 6. INSTALL MASTER CYLINDER BOOT

Facing the up mark on the master cylinder boot upwards, install the cylinder boot to the master cylinder.

## INSTALLATION OF MASTER CYLINDER

(See page [BR-10](#))

### 1. ADJUST LENGTH OF BRAKE BOOSTER PUSH ROD BEFORE INSTALLING MASTER CYLINDER

(See page [BR-17](#))

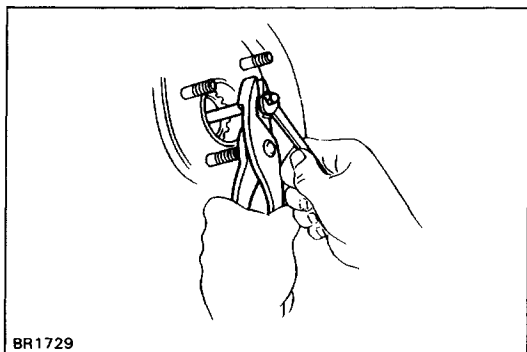

BR1729

### 2. INSTALL MASTER CYLINDER

Install the master cylinder and gasket on the brake booster with four nuts.

Torque: 13 N-m (130 kgf-cm, 9 ft-lbf)

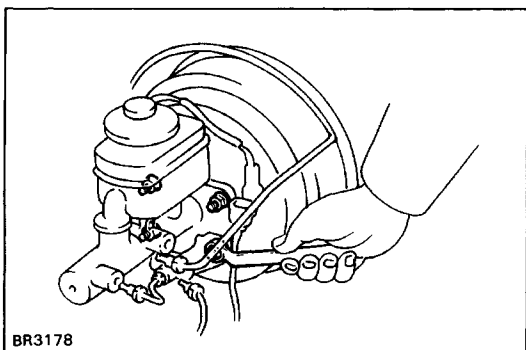

BR3178

### 3. CONNECT TWO BRAKE TUBES

Using SST, connect the brake tubes to the master cylinder. Torque the union nuts.

SST 09751-36011

Torque: 15 N-m (155 kgf-cm, 11 ft-lbf)

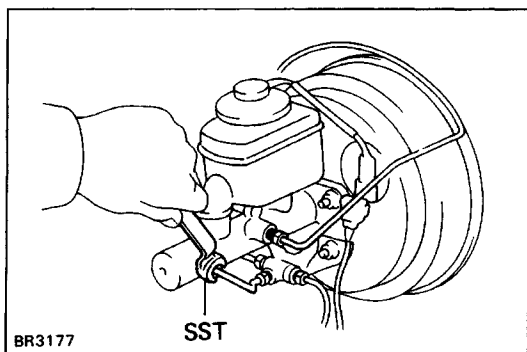

BR3177

### 4. CONNECT LEVEL WARNING SWITCH CONNECTOR

### 5. FILL BRAKE RESERVOIR WITH BRAKE FLUID AND BLEED BRAKE SYSTEM

(See page [BR-8](#))

### 6. CHECK FOR FLUID LEAKAGE

### 7. CHECK AND ADJUST BRAKE PEDAL

(See page [BR-6](#))

# BRAKE BOOSTER

## REMOVAL OF BRAKE BOOSTER

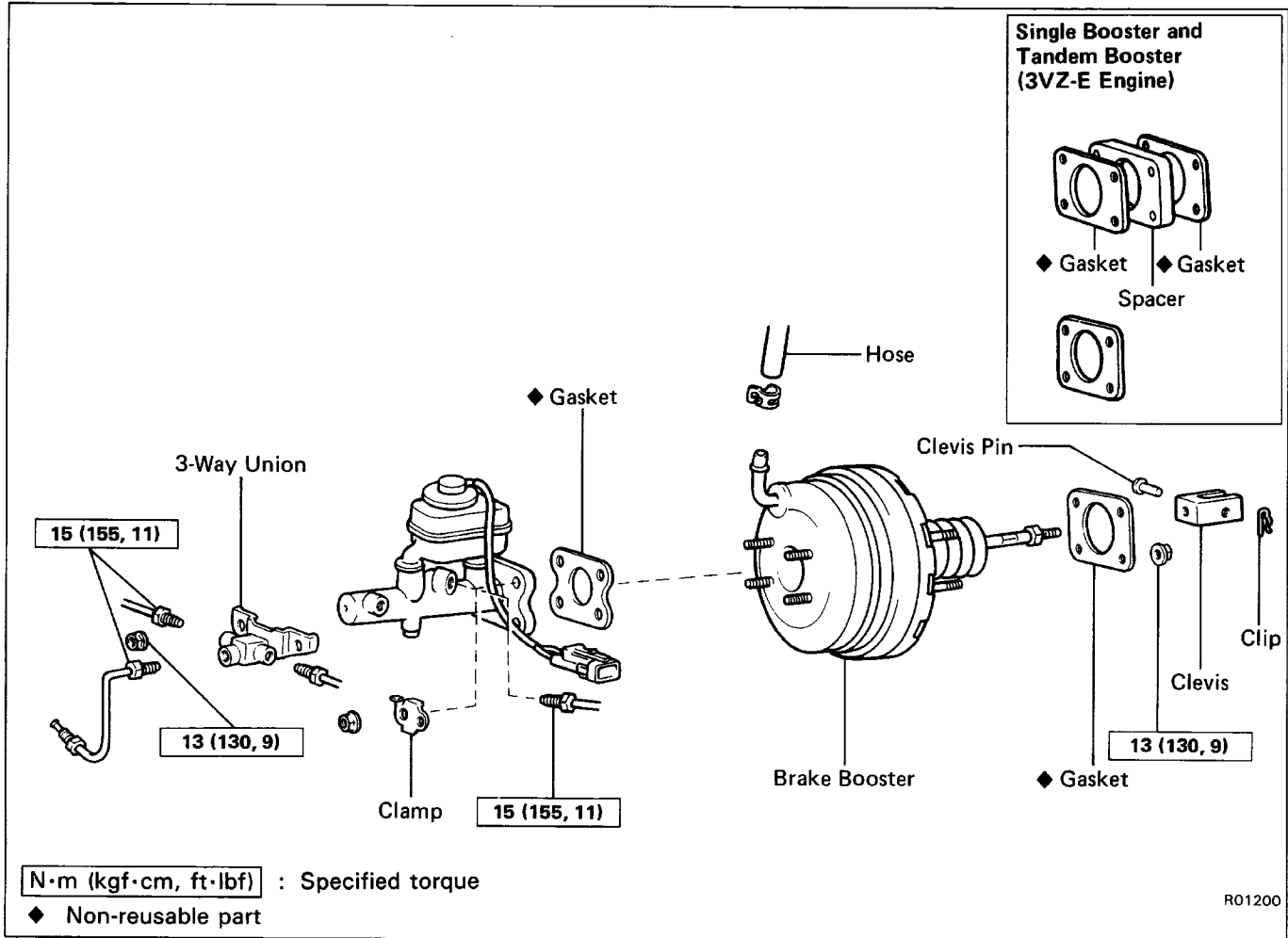

1. REMOVE MASTER CYLINDER  
(See page BR-10)
2. DISCONNECT VACUUM HOSE FROM BRAKE BOOSTER
3. REMOVE PEDAL RETURN SPRING
4. REMOVE CLIP AND CLEVIS PIN
5. REMOVE BRAKE BOOSTER, GASKET AND CLEVIS

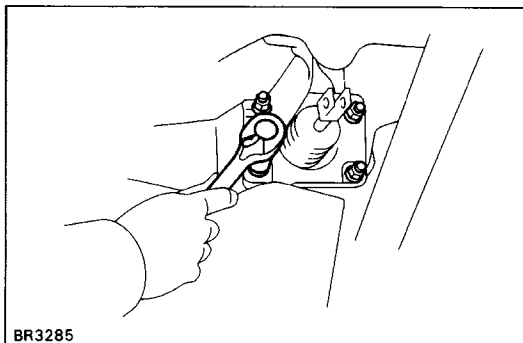

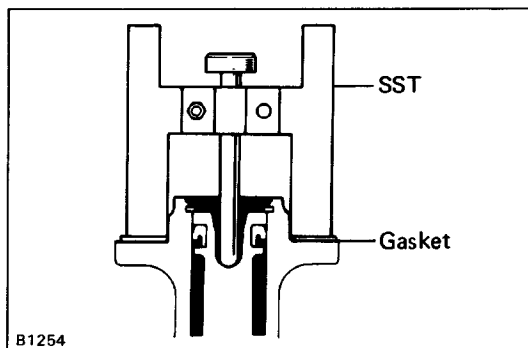

## INSTALLATION OF BRAKE BOOSTER

(See page [BR-16](#))

### 1. ADJUST LENGTH OF BOOSTER PUSH ROD

- (a) Install the gasket on the master cylinder.
- (b) Set the SST on the gasket, and lower the pin until its tip slightly touches the piston.  
SST 09737-00010

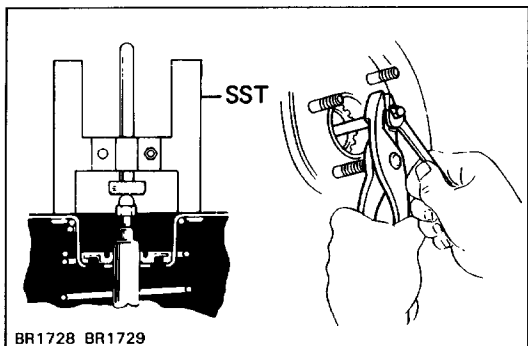

- (c) Turn the SST upside down, and set it on the booster.  
SST 09737-00010
- (d) Measure the clearance between the booster push rod and pin head (SST).  
**Clearance: 0 mm (0 in.)**
- (e) Adjust the booster push rod length until the push rod lightly touches the pin head.

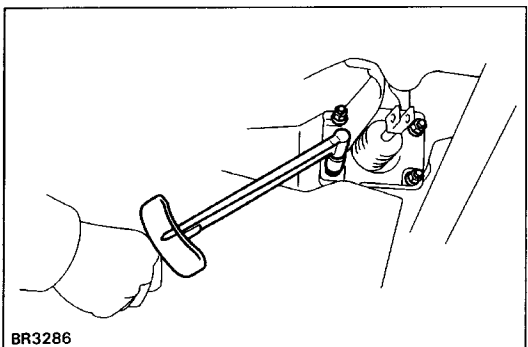

### 2. INSTALL BRAKE BOOSTER, GASKET AND CLEVIS

- (a) Install the booster and gasket.
- (b) Install the clevis.
- (c) Install and torque the booster mounting nuts.  
**Torque: 13 N-m (130 kgf-cm, 9 ft-lbf )**

### 3. CONNECT CLEVIS TO BRAKE PEDAL

Insert the clevis pin into the clevis and brake pedal and install the clip to the clevis pin.

### 4. INSTALL PEDAL RETURN SPRING

### 5. INSTALL MASTER CYLINDER

(See page [BR-15](#))

### 6. CONNECT HOSE TO BRAKE BOOSTER

### 7. FILL BRAKE RESERVOIR WITH BRAKE FLUID AND BLEED BRAKE SYSTEM

(See page [BR-8](#))

### 8. CHECK FOR FLUID LEAKAGE

### 9. CHECK AND ADJUST BRAKE PEDAL

(See page [BR-6](#))

### 10. PERFORM OPERATIONAL CHECK

(See page [BR-7](#))



# FRONT BRAKE 4WD (S12 + 12 Type Disc) COMPONENTS

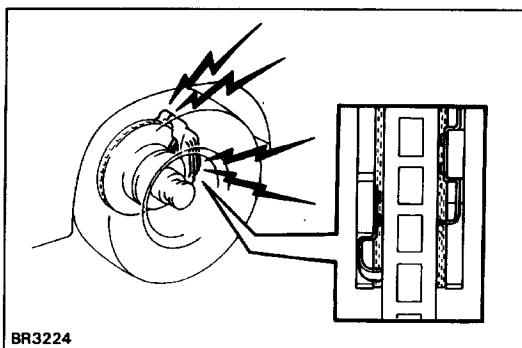
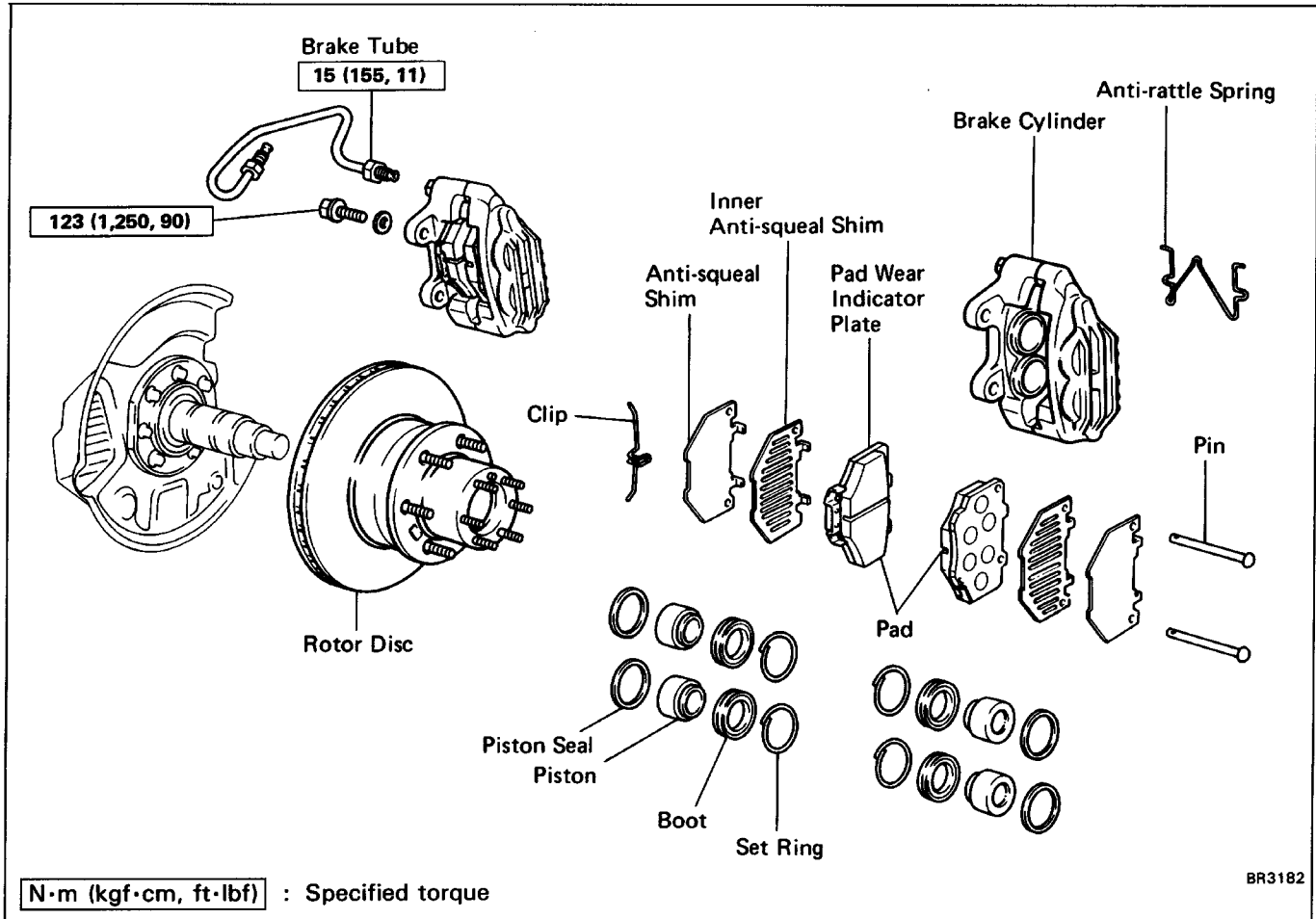

## REPLACEMENT OF BRAKE PADS

HINT: If a squealing noise occurs from the brakes while driving, check the pad wear indicator plate. If the pad wear indicator plate contacts the rotor disc, the brake pads should be replaced.

### 1. REMOVE FRONT WHEEL

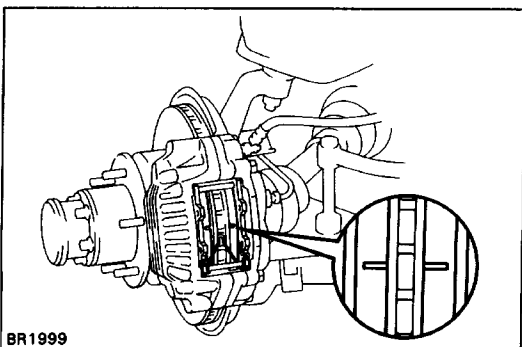

### 2. INSPECT PAD LINING THICKNESS

Check the pad thickness and replace pads if not within specification.

**Minimum thickness: 1.0 mm (0.039 in.)**

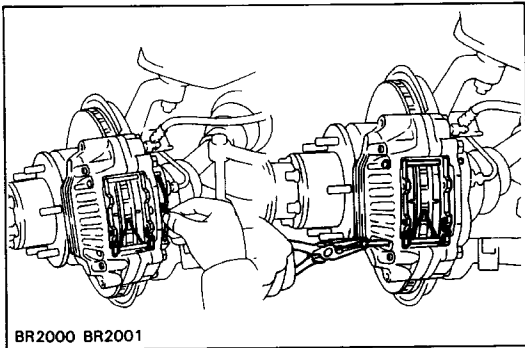

### 3. REMOVE FOLLOWING PARTS

- (a) Clip
- (b) Two pins
- (c) Anti-rattle spring
- (d) Two pads
- (e) Four anti-squeal shims

### 4. CHECK ROTOR DISC THICKNESS

(See step 2 on page BR-37)

### 5. CHECK ROTOR DISC RUNOUT

(See step 3 on page BR-37)

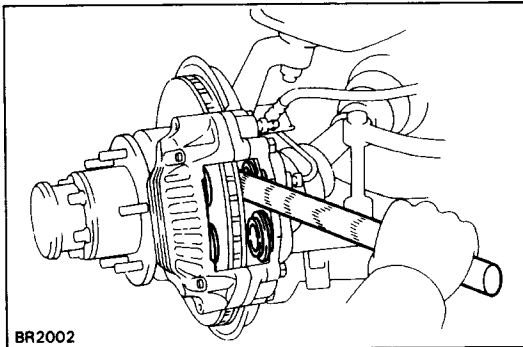

### 6. INSTALL NEW PADS

- (a) Draw out a small amount of brake fluid from the reservoir.
- (b) Press in the pistons with a hammer handle or an equivalent.  
HINT: Always change the pads on one wheel at a time as there is possibility of the opposite piston flying out.

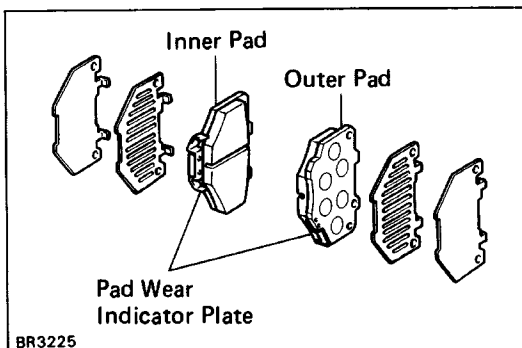

- (c) Install the four anti-squeal shims to new pads as shown.  
HINT: Apply disc brake grease to both sides of the inner anti-squeal shims.
- (d) Install the two pads as shown in the illustration.  
**NOTICE: Do not allow oil or grease to get on the rubbing face.**

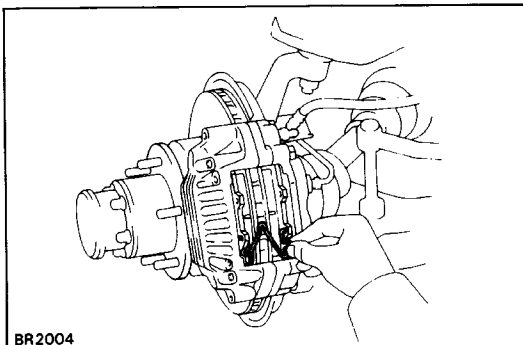

### 7. INSTALL ANTI-RATTLE SPRING

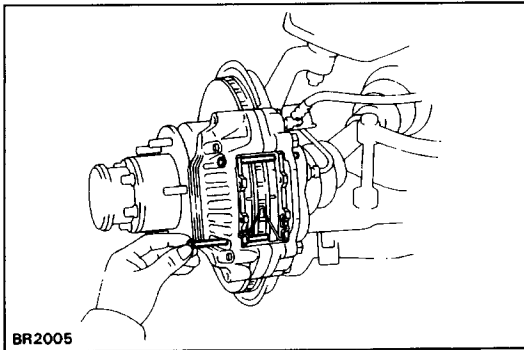

## 8. INSTALL TWO PINS

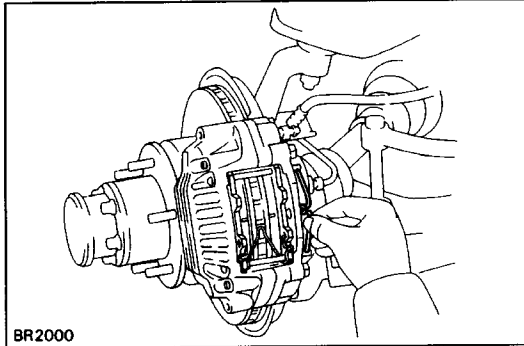

## 9. INSTALL CLIP

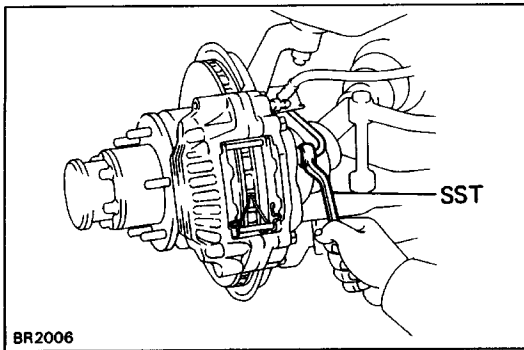

## REMOVAL OF CYLINDER

(See page [BR-33](#))

### 1. REMOVE FRONT WHEEL

### 2. DISCONNECT BRAKE TUBE

Using SST, disconnect the brake tube.  
Use a container to catch the brake fluid.  
SST 09751-36011

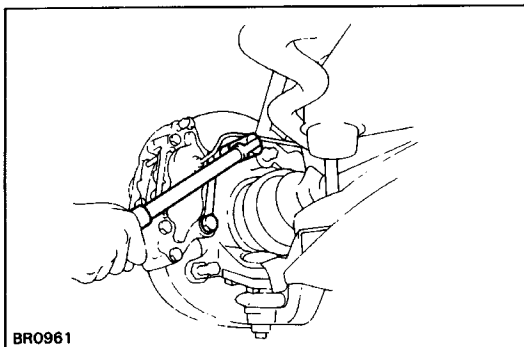

### 3. REMOVE CYLINDER

Remove the two mounting bolts and remove the cylinder.

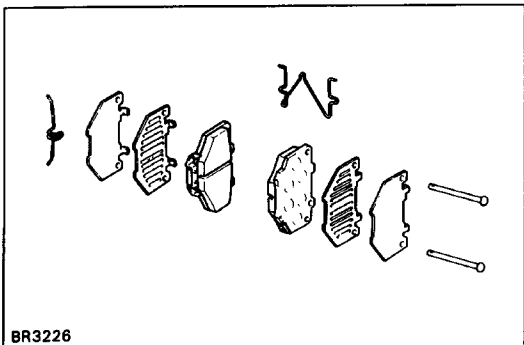

### 4. REMOVE FOLLOWING PARTS:

- Clip
- Two pins
- Anti-rattle spring
- Two pads
- Four anti-squeal shims

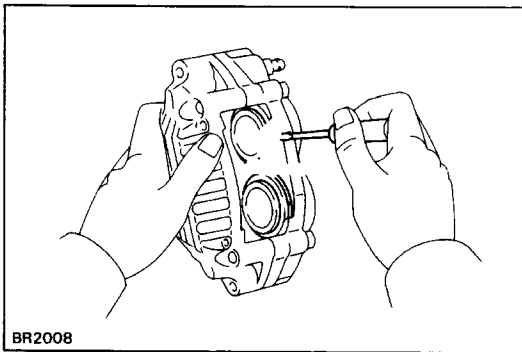

BR2008

## DISASSEMBLY OF CYLINDER

(See page BR-33)

### 1. REMOVE CYLINDER BOOT SET RINGS AND BOOTS

Using a screwdriver, remove the four cylinder boot set rings and four boots.

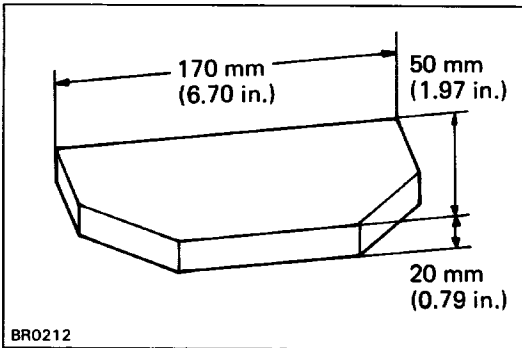

BR0212

### 2. REMOVE PISTONS FROM CYLINDER

(a) Prepare the wooden plate as shown in the illustration to hold the pistons.

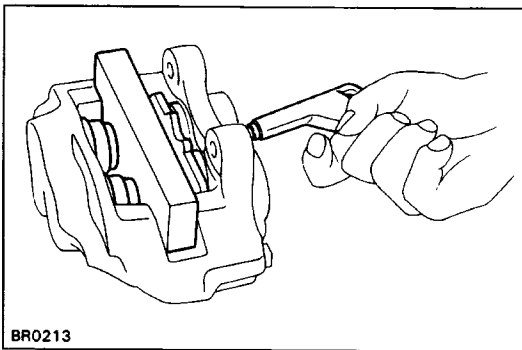

BR0213

(b) Place the plate between the pistons and insert a pad at one side.

(c) Use compressed air to remove the pistons alternately from the cylinder.

**NOTICE:** Do not place your fingers in front of the pistons when using compressed air.

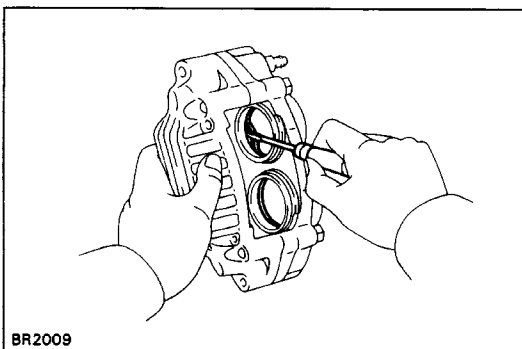

BR2009

### 3. REMOVE PISTON SEALS

Using a screwdriver, remove the four seals from the cylinder.

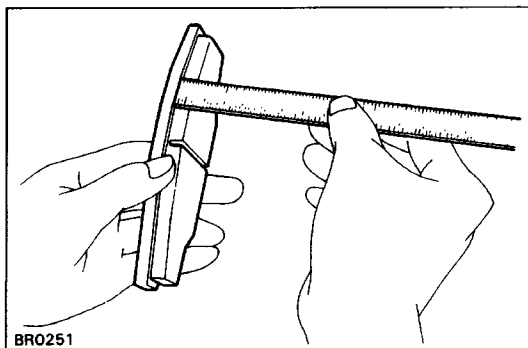

BR0251

## INSPECTION AND REPAIR OF FRONT BRAKE COMPONENTS

### 1. MEASURE PAD LINING THICKNESS

**Standard thickness: 9.5 mm (0.374 in.)**

**Minimum thickness: 1.5 mm (0.059 in.)**

Replace the pads if the thickness is less than the minimum (the 1.5 mm slit is no longer visible) or if it shows sign of uneven wear.

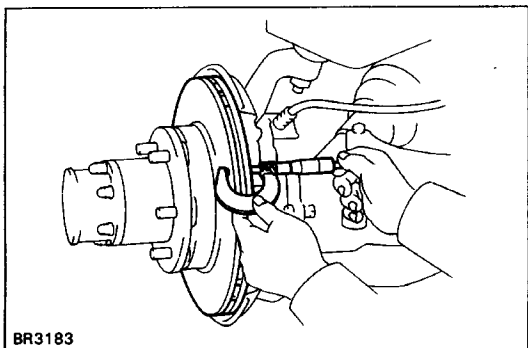

BR3183

### 2. MEASURE ROTOR DISC THICKNESS

**Standard thickness: 20.0 mm (0.787 in.)**

**Minimum thickness: 18.0 mm (0.709 in.)**

If the disc is scored or worn, or if thickness is less than minimum, repair or replace the disc.

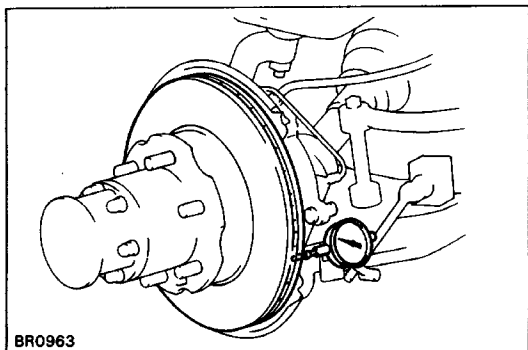

BR0963

### 3. MEASURE ROTOR DISC RUNOUT

Measure the rotor disc runout at 10 mm (0.39 in.) from the outer edge of the rotor disc.

**Maximum disc runout: 0.09 mm (0.0035 in.)**

If the runout is greater than maximum, replace the rotor disc.

**HINT:** Before measuring the runout, confirm that the front bearing play is within specification.

### 4. IF NECESSARY, REPLACE ROTOR DISC

- (a) Remove the front axle hub.
- (b) Remove the disc from the axle hub.

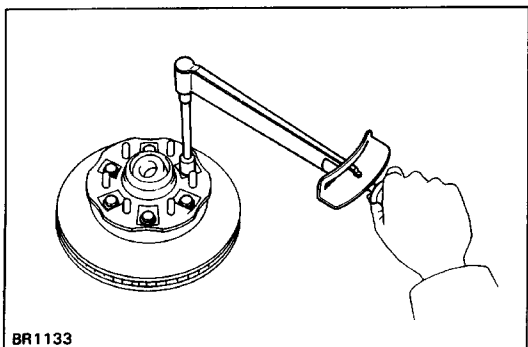

BR1133

- (c) Install a new rotor disc and torque the bolts.  
**Torque: 64 N-m (650 kgf-cm, 47 ft-lbf)**
- (d) Install the axle hub and adjust the front bearing pre-load.

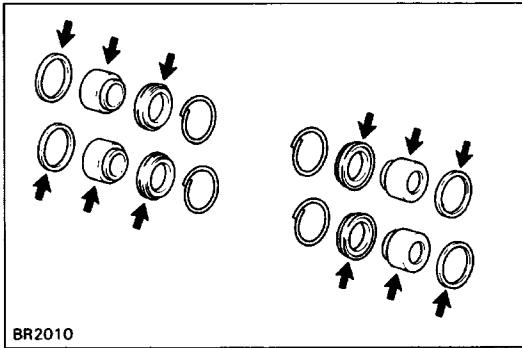
**ASSEMBLY OF CYLINDER**

(See page [BR-33](#))

1. APPLY LITHIUM SOAP BASE GLYCOL GREASE TO PARTS INDICATED BY ARROWS

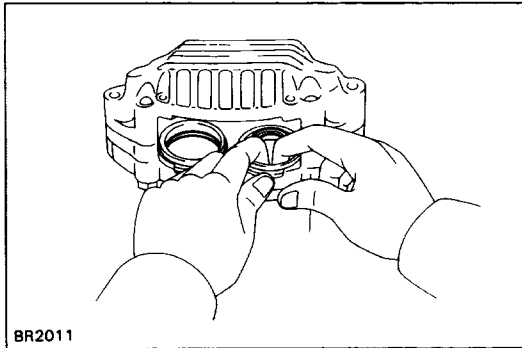

2. INSTALL PISTON SEALS INTO CYLINDER

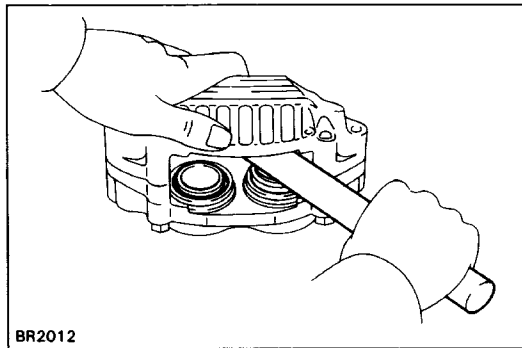

3. INSTALL PISTONS INTO CYLINDER

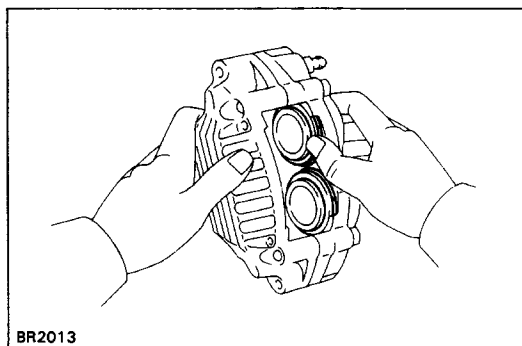

4. INSTALL CYLINDER BOOTS AND SET RINGS INTO CYLINDER

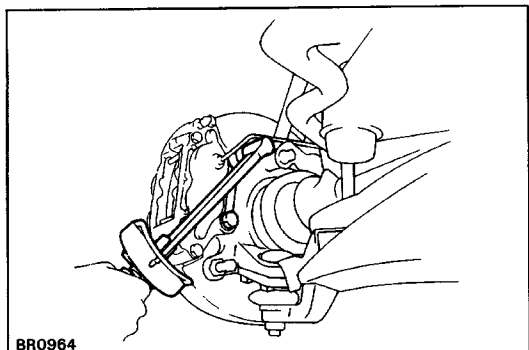

## INSTALLATION OF CYLINDER

(See page [BR-33](#))

### 1. INSTALL CYLINDER

Install the brake cylinder, and torque the two mounting bolts.

Torque: 123 N-m (1,250 kgf-cm, 90 ft-lbf)

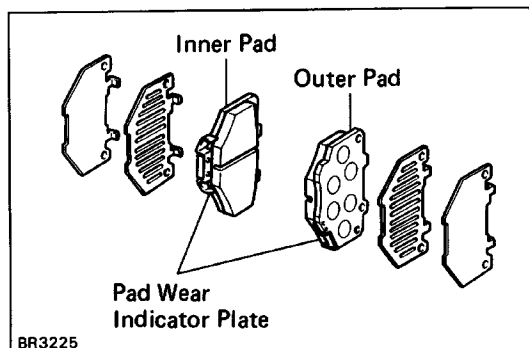

### 2. INSTALL PADS

(See steps 6 to 9 on pages [BR-34](#) and 35)

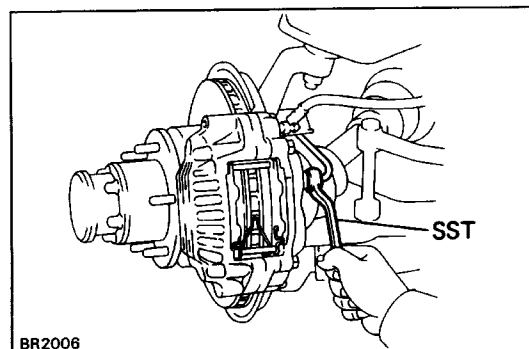

### 3. CONNECT BRAKE TUBE

Using SST, connect the brake tube.

SST 09751-36011

Torque: 15 N-m (155 kgf-cm, 11 ft-lbf)

### 4. FILL BRAKE RESERVOIR WITH BRAKE FLUID AND BLEED BRAKE SYSTEM

(See page [BR-8](#))

### 5. CHECK FOR FLUID LEAKAGE

### 6. INSTALL FRONT WHEEL

# REAR BRAKE 4WD COMPONENTS

Bellcrank No. 1: For Right Wheel  
Bellcrank No. 2: For Left Wheel

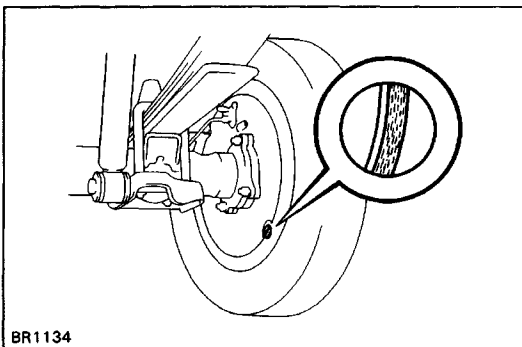
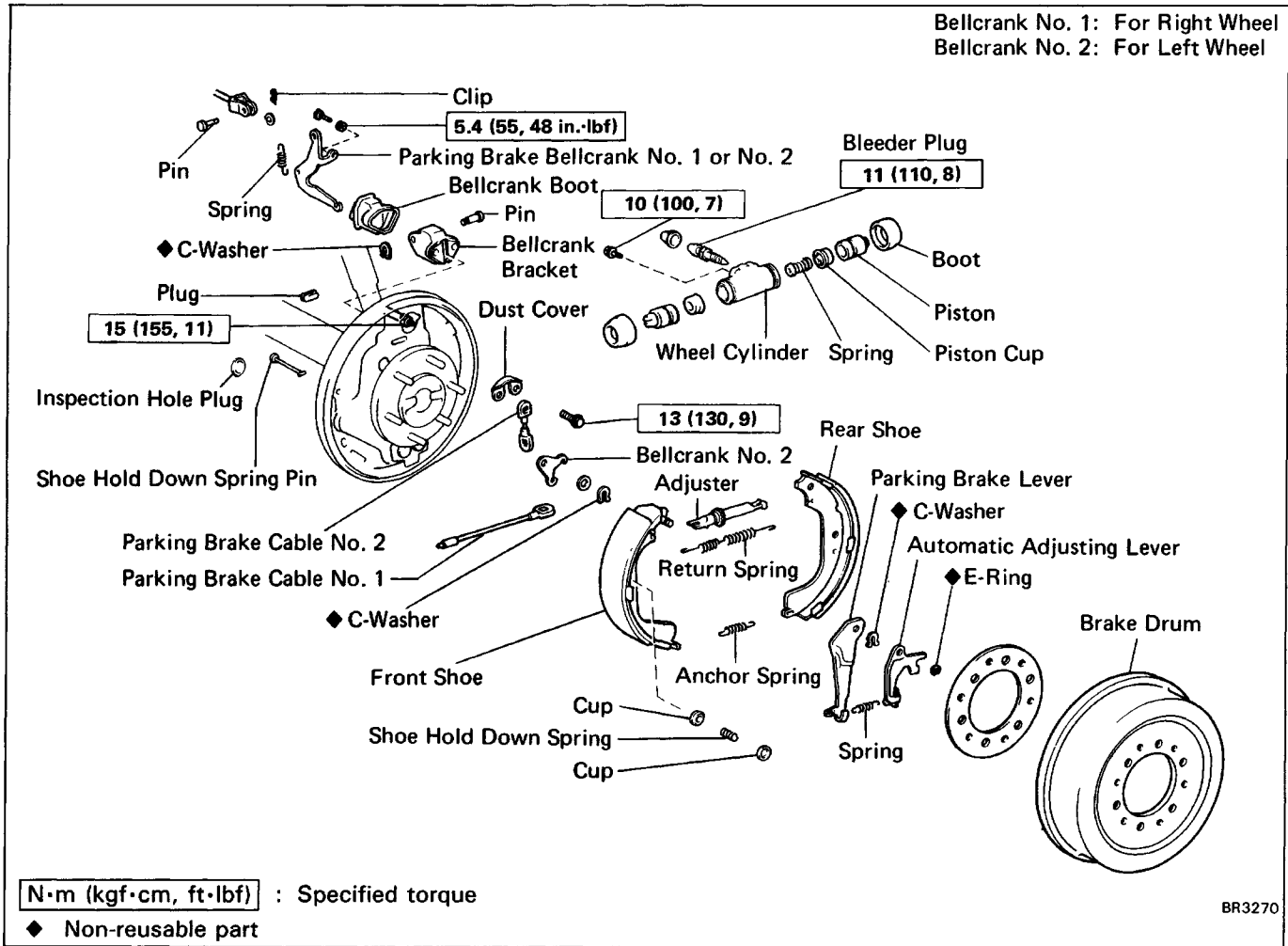

## REMOVAL OF REAR DRUM BRAKE

### 1. INSPECT SHOE LINING THICKNESS

Remove the inspection hole plug, and check the shoe lining thickness through the hole.

If less than minimum, replace the shoes.

**Minimum thickness: 1.0 mm (0.039 in.)**

### 2. REMOVE REAR WHEEL

### 3. REMOVE BRAKE DRUM

**HINT:** If the brake drum cannot be removed easily, perform the following.

- Insert a screwdriver through the hole in the backing plate, and hold the automatic adjusting lever away from the adjusting bolt.
- Using another screwdriver, reduce the brake shoe adjustment by turning the adjusting bolt clockwise.

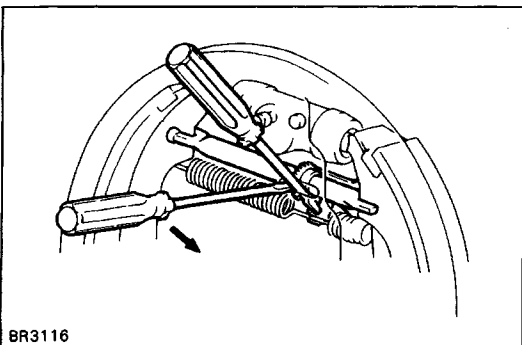



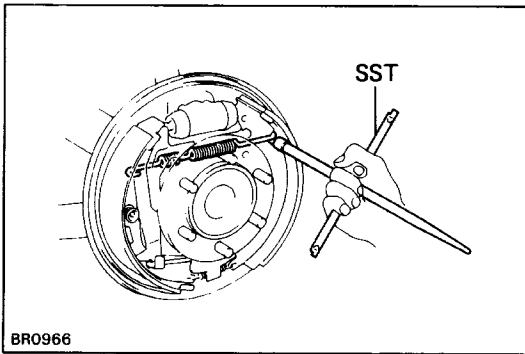

#### 4. REMOVE REAR SHOE

- (a) Using SST, disconnect the return spring.  
SST 09703-30010

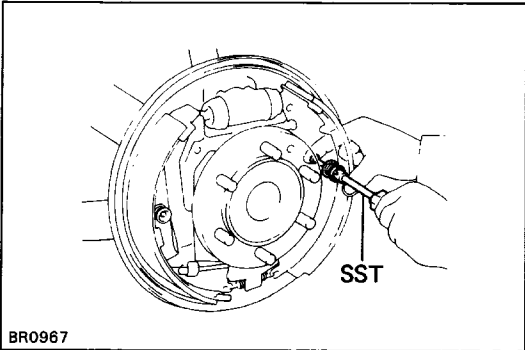

- (b) Using SST, remove the shoe hold-down spring, cups and pin.  
SST 09718-00010
- (c) Disconnect the anchor spring from the rear shoe and remove the rear shoe.
- (d) Remove the anchor spring from the front shoe.

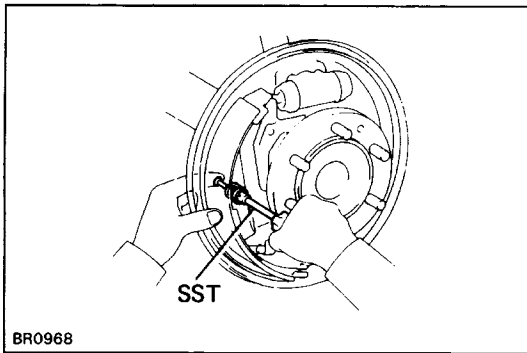

#### 5. REMOVE FRONT SHOE

- (a) Using SST, remove the shoe hold-down spring, cups and pin.  
SST 09718-00010
- (b) Remove the return spring from the front shoe.

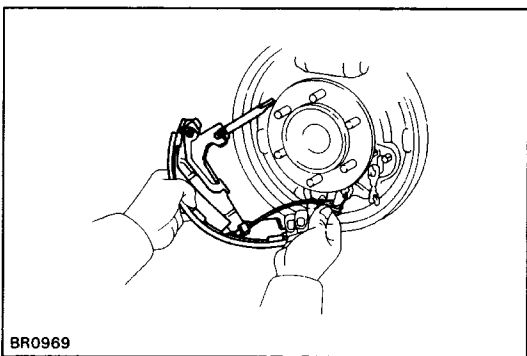

- (c) Disconnect the parking brake cable No. 1 from the parking brake bellcrank No. 3.
- (d) Remove the front shoe with adjuster.
- (e) Disconnect the parking brake cable from the front shoe.

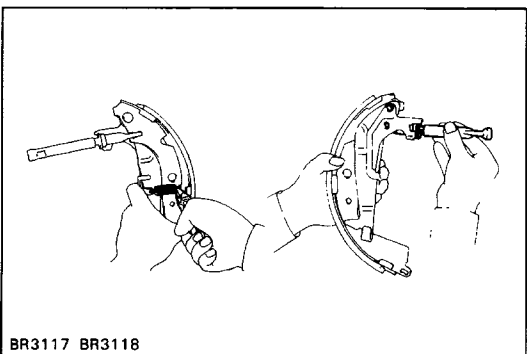

#### 6. REMOVE ADJUSTER FROM FRONT SHOE

- (a) Remove the adjusting lever spring.
- (b) Remove the adjuster.

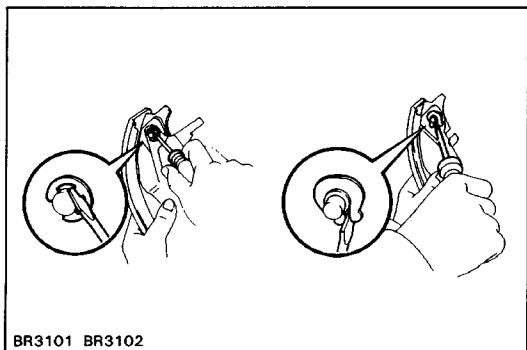

## 7. REMOVE AUTOMATIC ADJUSTING LEVER AND PARKING BRAKE LEVER

- (a) Remove the E-ring.
- (b) Remove the automatic adjusting lever.
- (c) Remove the C-washer.
- (d) Remove the parking brake lever.

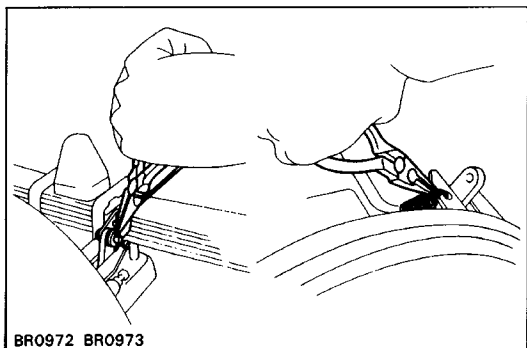

## 8. REMOVE AND DISASSEMBLE PARKING BRAKE BELLCRANK

- (a) Remove the clip and disconnect the parking brake cable.
- (b) Remove the tension spring.

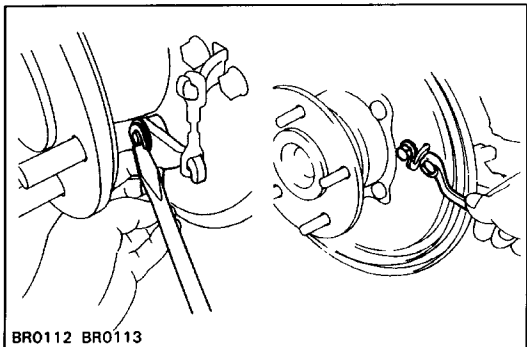

- (c) Using a screwdriver, remove the bellcrank No.3 from the backing plate with parking brake cable No. 2.
- (d) Remove the parking brake bellcrank No. 1 or No. 2 and dust cover with the two bolts.
- (e) Remove the bellcrank boot from the bellcrank bracket.

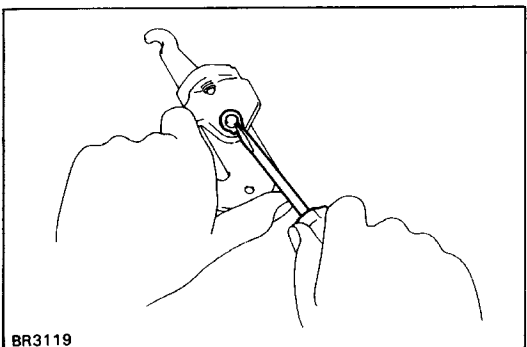

- (f) Remove the C-washer and pin.
- (g) Remove the parking brake bellcrank from the bellcrank bracket.

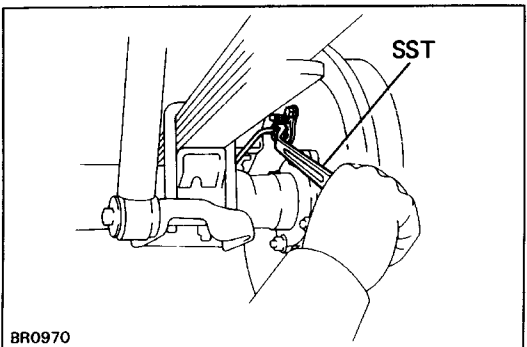

## 9. REMOVE WHEEL CYLINDER

- (a) Using SST, disconnect the brake tube. Use a container to catch the brake fluid.  
SST 09751-36011
- (b) Remove the two bolts and the wheel cylinder.

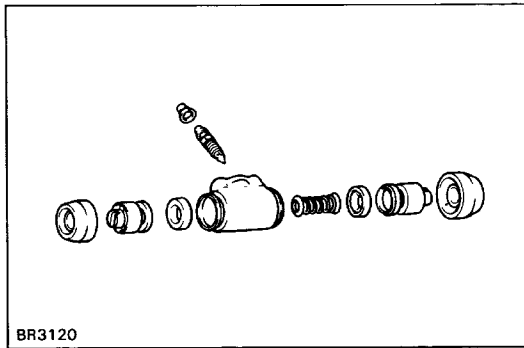

## 10. DISASSEMBLE WHEEL CYLINDER

Remove the following parts from the wheel cylinder:

- Two boots
- Two pistons
- Two piston cups
- Spring

## INSPECTION AND REPAIR OF REAR BRAKE COMPONENTS

### 1. INSPECT DISASSEMBLED PARTS

Inspect the disassembled parts for wear, rust or damage.

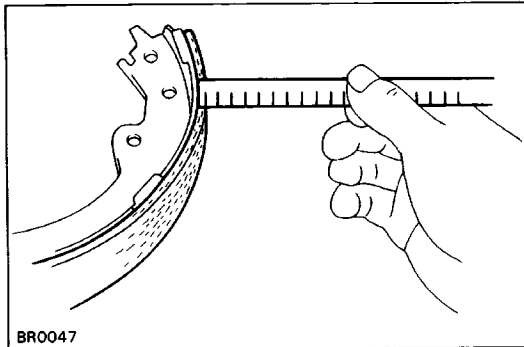

### 2. MEASURE BRAKE SHOE LINING THICKNESS

**Standard thickness: 6.0 mm (0.236 in.)**

**Minimum thickness: 1.0 mm (0.039 in.)**

If the shoe lining is less than minimum or shows signs of uneven wear, replace the brake shoes.

**HINT:** If any of the brake shoes have to be replaced, replace all of the rear shoes in order to maintain even braking.

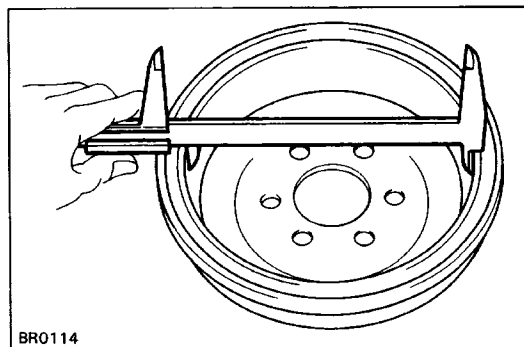

### 3. MEASURE BRAKE DRUM INSIDE DIAMETER

**Standard inside diameter: 295.0 mm (11.61 in.)**

**Maximum inside diameter: 297.0 mm (11.69 in.)**

If the drum is scored or worn, the brake drum may be lathed to the maximum inside diameter.

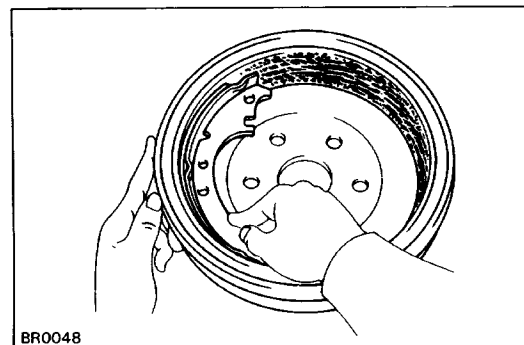

### 4. INSPECT REAR BRAKE LINING AND DRUM FOR PROPER CONTACT

If the contact between the brake lining and drum is improper, repair the lining with a brake shoe grinder, or replace the brake shoe assembly.

**ASSEMBLY OF REAR BRAKES**

(See page BR-55)

HINT: Assemble the parts in the correct direction as shown.

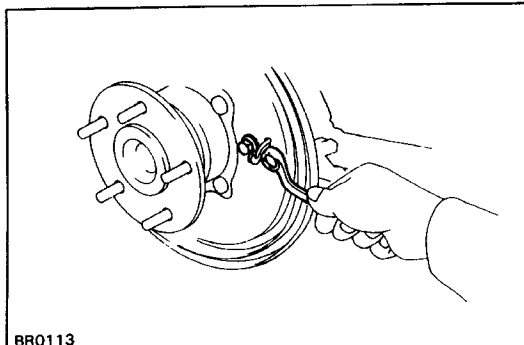
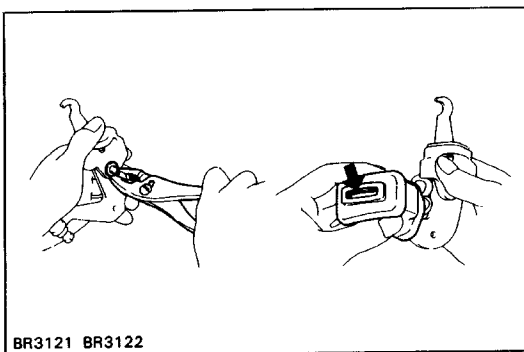
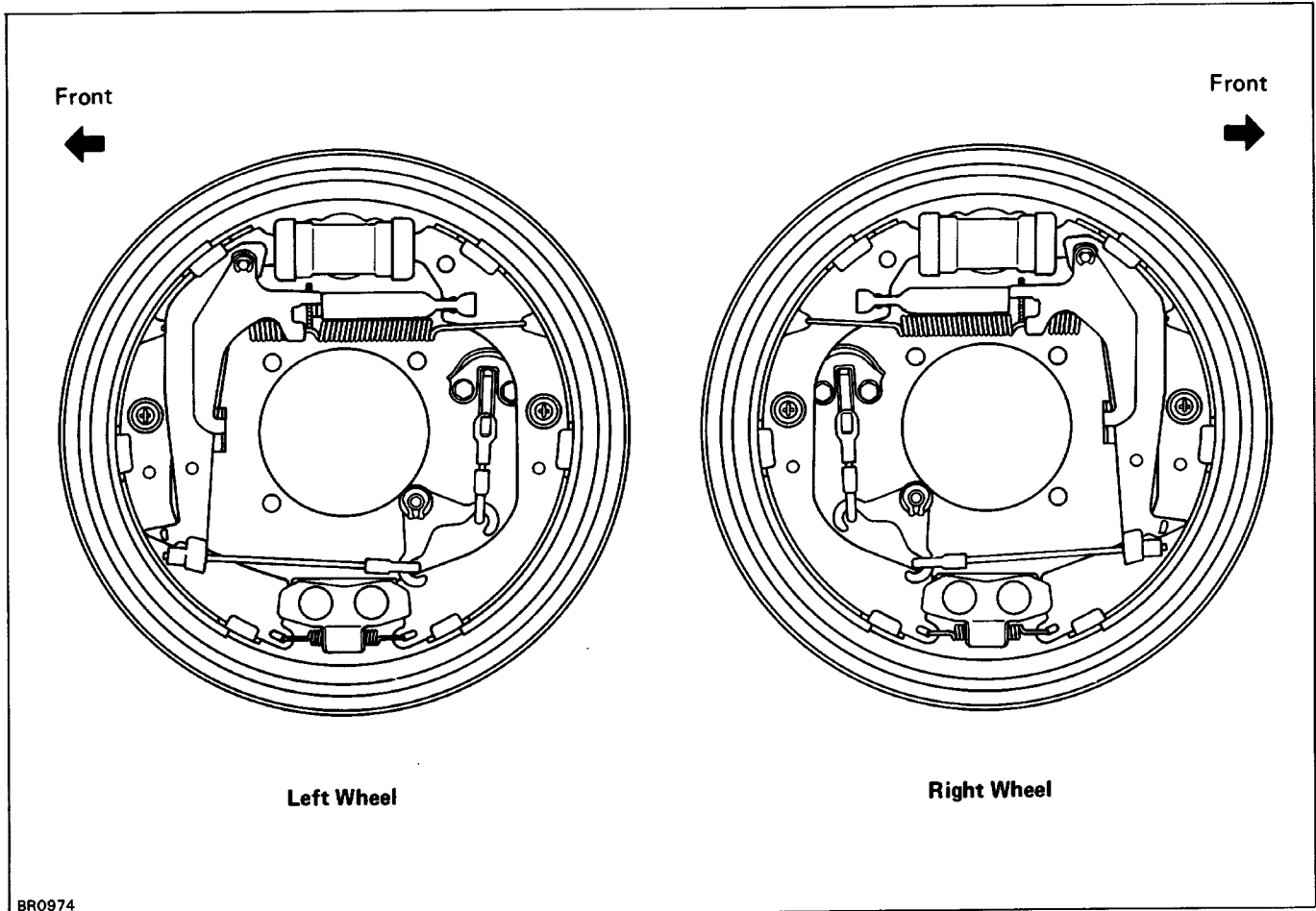
**1. ASSEMBLE AND INSTALL PARKING BRAKE BELL-CRANK**

- (a) Apply high temperature grease to the rotating parts of the bellcrank.
- (b) Apply lithium soap base glycol grease to the bellcrank boot and insert it to the parking brake bellcrank.
- (c) Install the parking brake bellcrank to the bellcrank bracket.
- (d) Install the pin with a new C-washer.
- (e) Install the bellcrank boot to the parking brake bellcrank bracket.
- (f) Install the parking brake bellcrank and dust cover on the backing plate.

**Torque: 13 N-m (130 kgf-cm, 9 ft-lbf)**

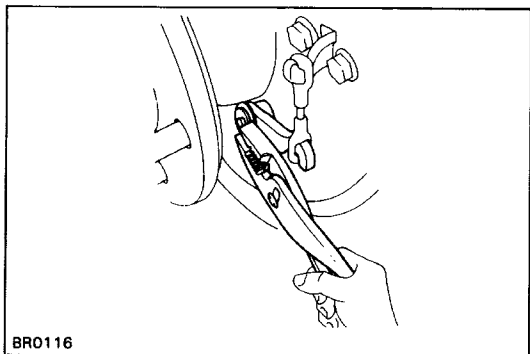

BR0116

- (g) Install the parking brake cable No.2 to the parking brake bellcrank No. 1 or No. 2.
- (h) Hook the bellcrank No. 3 to the cable No. 2, and then install the bellcrank No.3 with a new C-washer.

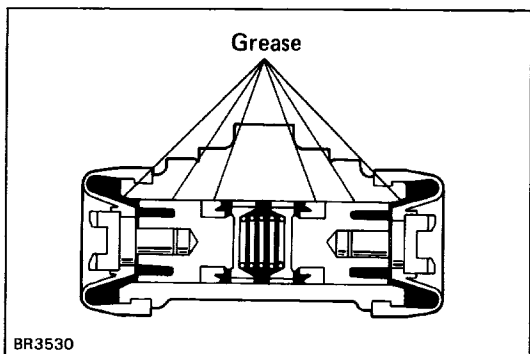

BR3530

## 2. APPLY LITHIUM SOAP BASE GLYCOL GREASE TO FOLLOWING PARTS:

- (a) Two piston cups
- (b) Two pistons

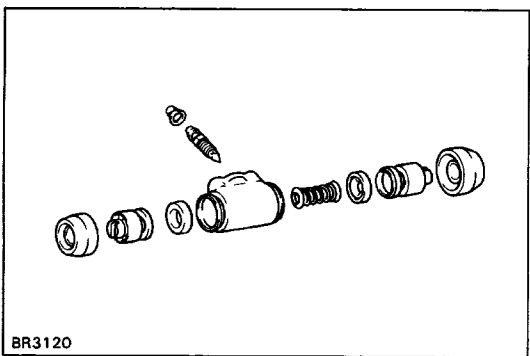

BR3120

## 3. ASSEMBLE WHEEL CYLINDER

- (a) Install the cup to the each piston.
- (b) Install the spring and two pistons into the wheel cylinder. Make sure flanges of the cups are pointed inward.
- (c) Install the two boots.

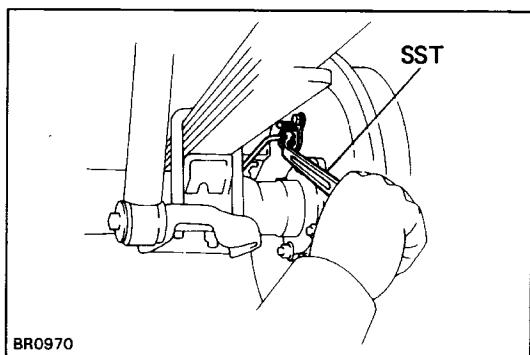

BR0970

## 4. INSTALL WHEEL CYLINDER

- (a) Install the wheel cylinder on the backing plate with two bolts.  
**Torque: 10 N-m (100 kgf-cm, 7 ft-lbf)**
- (b) Using SST, connect the brake tube.  
SST 09751-36011  
**Torque: 15 N-m (155 kgf-cm, 11 ft-lbf)**

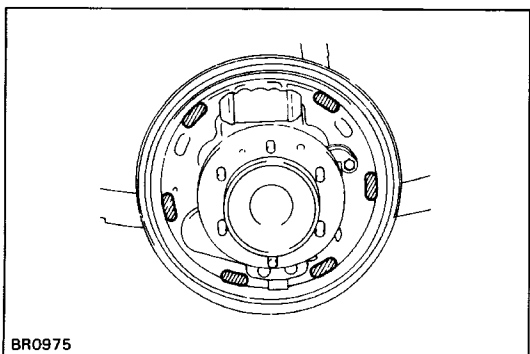

BR0975

## 5. APPLY HIGH TEMPERATURE GREASE TO BACKING PLATE AND ADJUSTER

- (a) Apply high temperature grease to the brake shoe contact surfaces as shown.

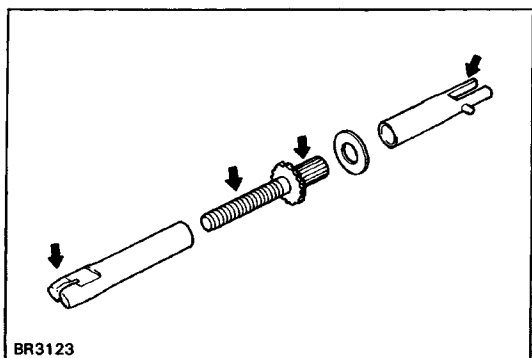

- (b) Apply high temperature grease to the adjuster bolt threads and ends.

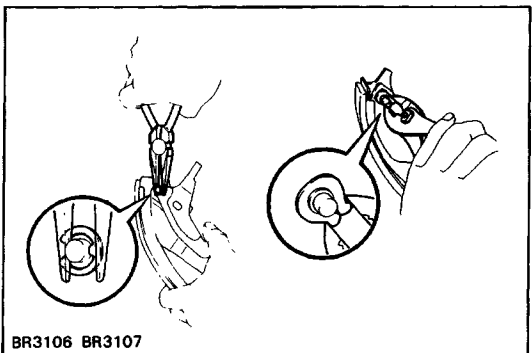

## 6. INSTALL PARKING BRAKE LEVER AND AUTOMATIC ADJUSTING LEVER

- (a) Install the parking brake lever with a new C-washer.  
 (b) Install the automatic adjusting lever with the E-ring.

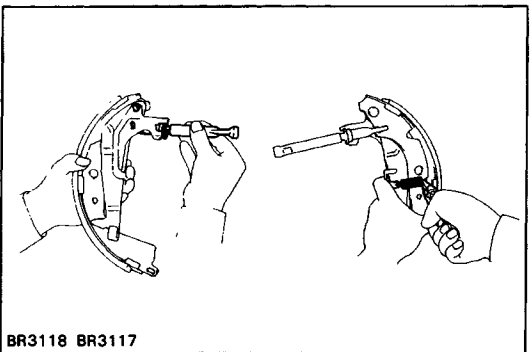

## 7. INSTALL ADJUSTER TO FRONT SHOE

- (a) Install the adjuster to the adjust lever.  
 (b) Install the adjust lever spring.

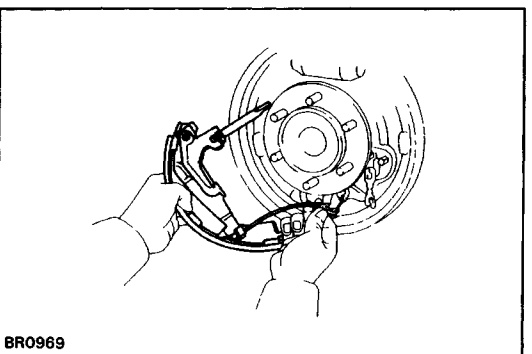

## 8. INSTALL FRONT SHOE

- (a) Install the parking brake cable No. 1 to the parking brake shoe lever.  
 (b) Hook the another side of the cable No. 1 to the bellcrank No.3.  
 (c) Install the return spring to the front shoe.

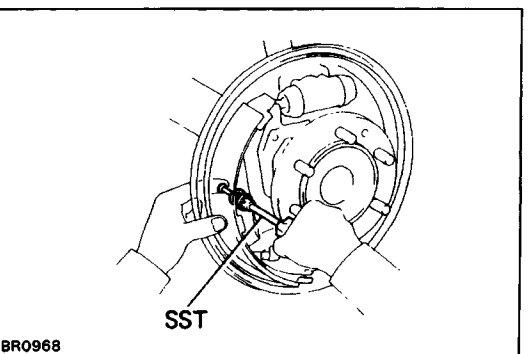

- (d) Set the front shoe in place with the end of the shoe inserted in the piston.  
 (e) Using SST, install the shoe hold-down spring, cups and pin.

SST 09718-00010

**NOTICE:** Do not allow oil or grease to get on the rubbing face.

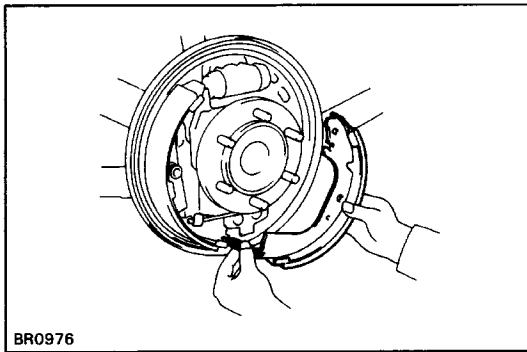

## 9. INSTALL REAR SHOE

- (a) Install the anchor spring between the front and rear shoes.
- (b) Set the rear shoe in place with the end of the shoe inserted in the wheel cylinder and the adjuster in place.

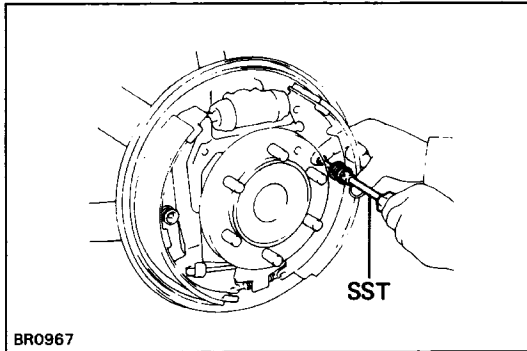

- (c) Using SST, install the shoe hold down spring, cups and pin.  
SST 09718-00010  
**NOTICE: Do not allow oil or grease to get on the rubbing face.**

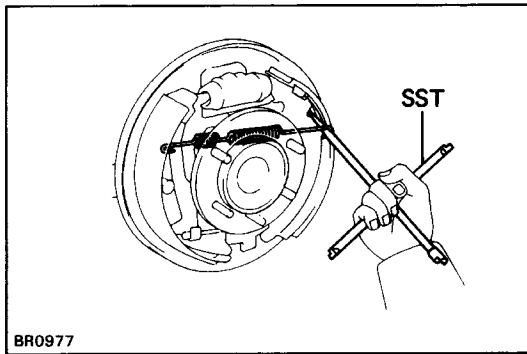

- (d) Using SST, connect the return spring.  
SST 09718-00010

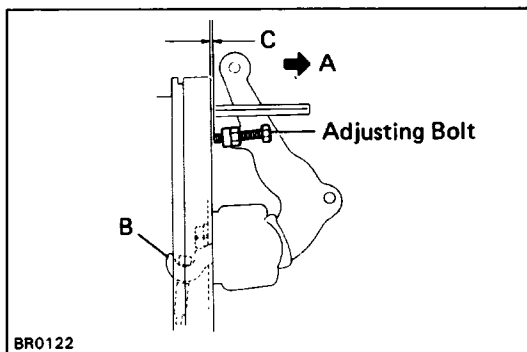

## 10. ADJUST BELLCRANK

- (a) Lightly pull the bellcrank in direction A until there is no slack at part B.
- (b) In this condition, turn the adjusting bolt so that dimension C will be 0.4 – 0.8 mm (0.016 – 0.031 in.).
- (c) Lock the adjust bolt with the lock nut.

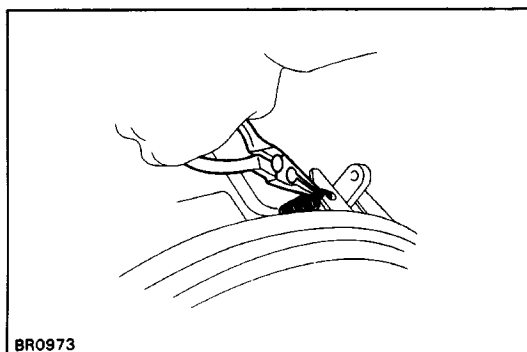

- (d) Connect the parking brake cable to the parking brake bellcrank and install the clip.
- (e) Install the tension spring.

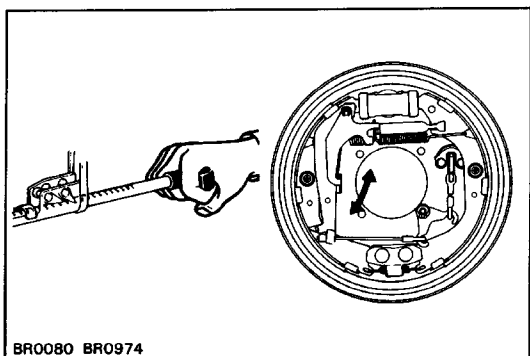

## 11. CHECK OPERATION OF AUTOMATIC ADJUSTING MECHANISM

- (a) Move the parking brake lever of the front shoe back and forth, as shown. Check that the adjuster turns.  
If the adjuster does not turn, check for incorrect installation of the rear brakes.
- (b) Adjust the adjuster length to the shortest possible amount.
- (c) Install the brake drum.
- (d) Pull the parking brake lever all the way up until a clicking sound can no longer be heard.

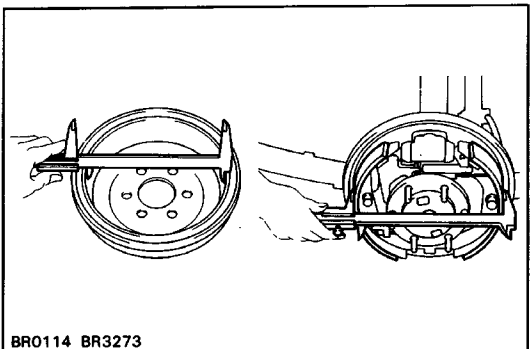
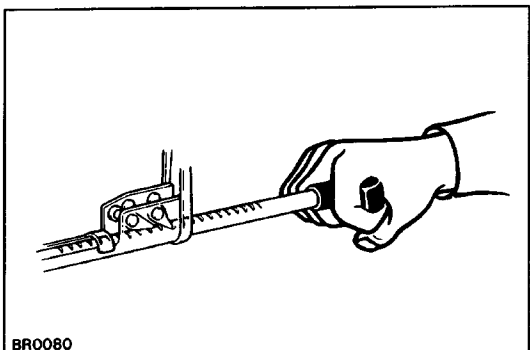

## 12. CHECK CLEARANCE BETWEEN BRAKE SHOES AND DRUM

- (a) Remove the brake drum.
- (b) Measure the brake drum inside diameter and diameter of the brake shoes. Check that the difference between the diameters is the correct shoe clearance.

**Shoe clearance: 0.6 mm (0.024 in.)**

If incorrect, check the parking brake system.

## 13. INSTALL BRAKE DRUM

## 14. INSTALL REAR WHEEL

## 15. FILL BRAKE RESERVOIR WITH BRAKE FLUID AND BLEED BRAKE SYSTEM (See page [BR-8](#))

## 16. CHECK FOR FLUID LEAKAGE



# LOAD SENSING PROPORTIONING AND BY-PASS VALVE (LSP & BV) COMPONENTS

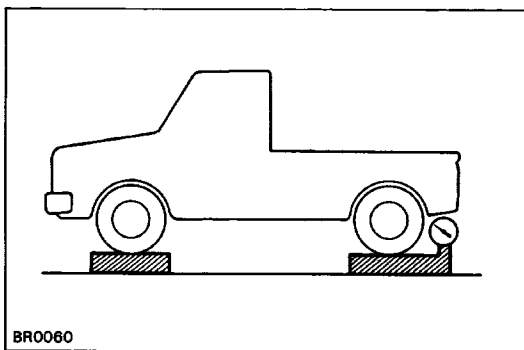
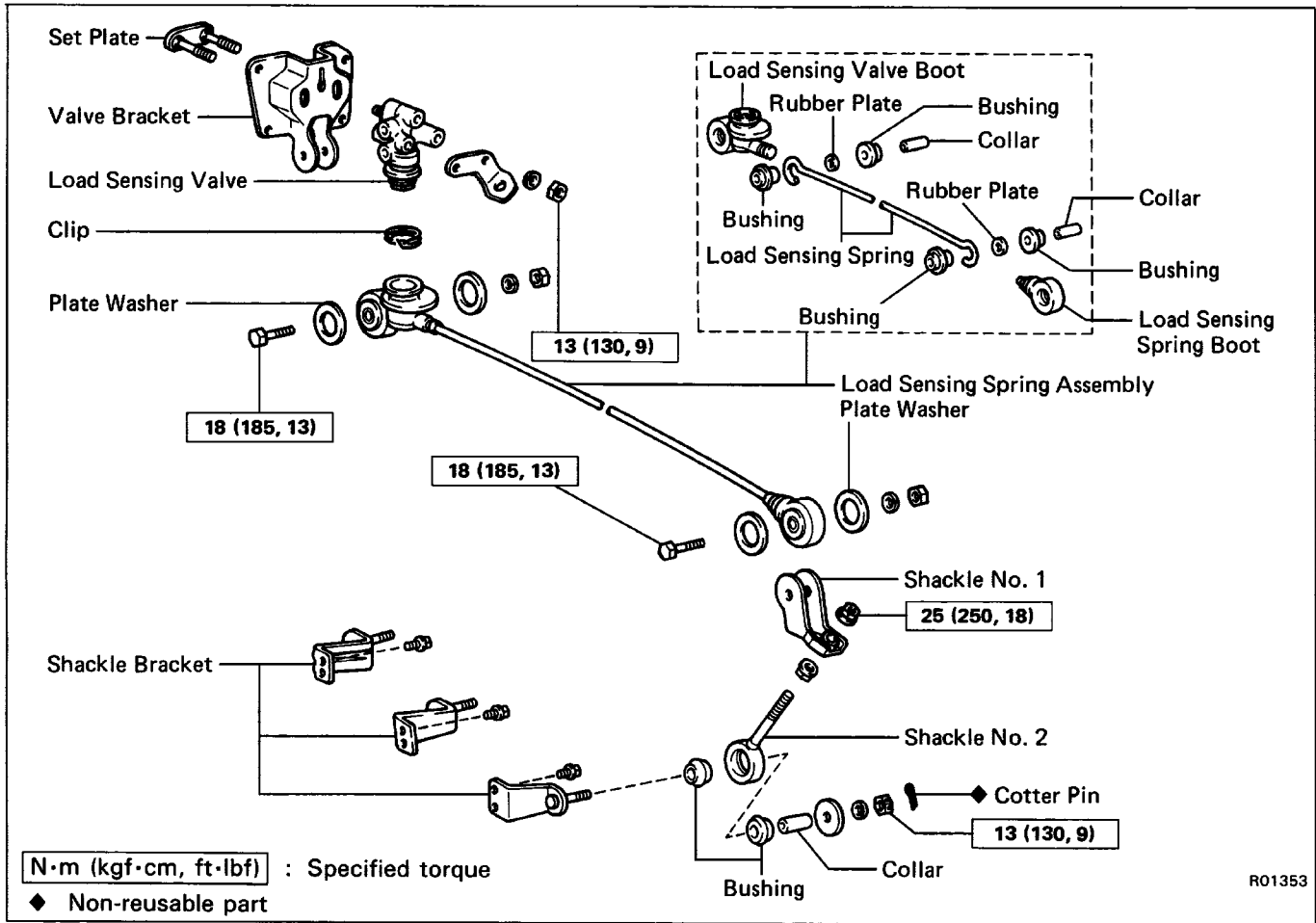

## CHECK AND ADJUSTMENT OF FLUID PRESSURE

### 1. SET REAR AXLE LOAD

Rear axle load (includes vehicle weight):

2WD 1 ton, C & C (SRW)	900 kg (1,984 lb)
1/2 ton	700 kg (1,543 lb)
C & C (DRW)	1,150 kg (2,535 lb)
4WD	800 kg (1,764 lb)

HINT: (For C & C)

If the vehicle unladen weight exceeds the specification above, set the rear axle load to the specification shown below. (See step 4 on page BR-65)

Rear axle load (includes vehicle weight):

SRW	1,678 kg (3,699 lb)
DRW	1,996 kg (4,400 lb)

### 2. INSTALL LSPV GAUGE (SST) AND BLEED AIR

SST 09709-29017

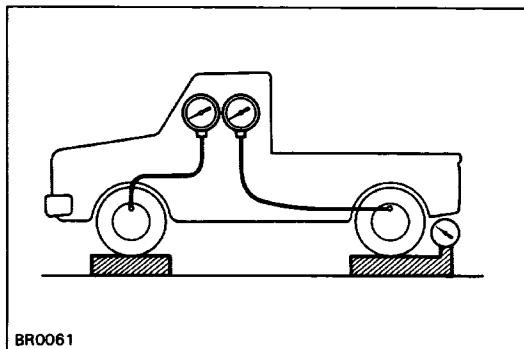

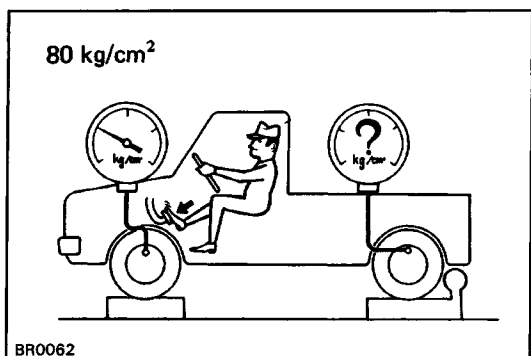

**3. RAISE FRONT BRAKE PRESSURE TO 7,845 kPa (80 kgf/cm<sup>2</sup>, 1,138 psi) AND CHECK REAR BRAKE PRESSURE**

Rear brake pressure:

- 2WD 1 ton, C & C (SRW) 4,413±490 kPa  
(45±5kgf/cm<sup>2</sup>, 640±71 psi)
- 1/2 ton 4,315 ± 490 kPa  
(44±5 kgf/cm<sup>2</sup>, 626 ± 71 psi)
- C & C (DRS) 4,707 ± 490 kPa  
(48±5 kgf/cm<sup>2</sup>, 683 ± 71 psi )
- 4WD Regular cab 3,923±490 kPa  
(40±5 kgf/cm<sup>2</sup>, 569±71 psi )
- Extra cab 4,315±490 kPa  
(43±5 kgf/cm<sup>2</sup>, 626±71 psi)

HINT: The brake pedal should not be depressed twice and/or returned while setting to the specified pressure. Read the value of rear brake pressure two seconds after adjusting the specified fluid pressure. If the brake pressure is incorrect, adjust the fluid pressure.

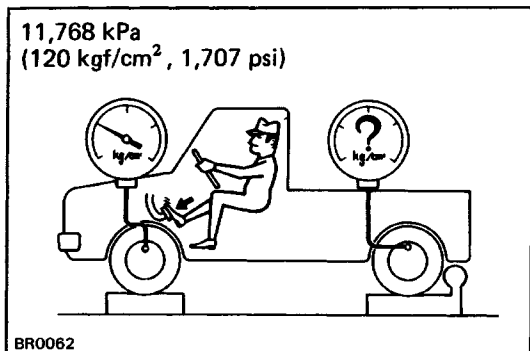

**4. (C&C)**

**RAISE FRONT BRAKE PRESSURE TO 11,768 kPa (120 kgf/cm<sup>2</sup>, 1,707 psi) AND CHECK REAR BRAKE PRESSURE**

Rear brake pressure:

- SRW 9,709 ± 588 kPa  
(99 ± 6 kgf/cm<sup>2</sup>, 1,408 ± 85 psi)
- DRW 8,336 ± 588 kPa  
(85 ± 6 kgf/cm<sup>2</sup>, 1,209 ± 85 psi)

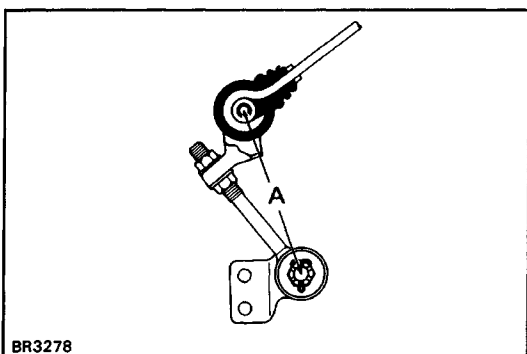

**5. IF NECESSARY, ADJUST FLUID PRESSURE**

(a) Adjust the length of the No.2 shackle.

Low pressure Lengthen A

High pressure Shorten A

Initial set:

- 2WD 78 mm (3.07 in.)
- 4WD 120 mm (4.72 in.)

Adjusting range:

- 2WD 72 – 84 mm (2.83 – 3.31 in.)
- 4WD 114 – 126 mm (4.49 – 4.96 in.)

HINT: One turn of the nut changes the fluid pressure as shown in the table below.

		Rear brake pressure
2WD	1/2 ton, C & C (SRW )	74 kPa (0.75 kgf/cm <sup>2</sup> , 11 psi)
	1 ton, C & C (DRW)	98 kPa (1.0 kgf/cm <sup>2</sup> , 14 psi)
4WD		59 kPa (0.6 kgf/cm <sup>2</sup> , 8.5 psi)

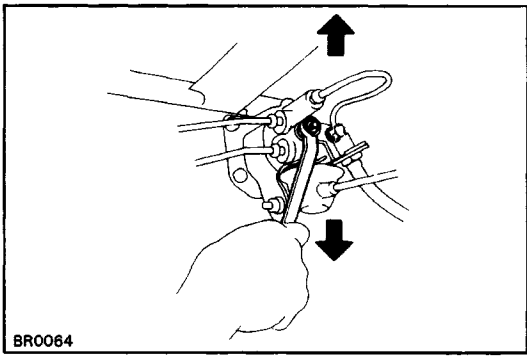

- (b) In event the pressure cannot be adjusted by the No. 1 shackle, raise or lower the valve body.  
 Low pressure – Lower  
 High pressure – Raise
- (c) Torque the nuts.  
**Torque: 13 N-m (130 kgf-cm, 9 ft-lbf)**
- (d) Adjust the length of the No. 1 shackle again.  
 If it cannot be adjusted, inspect the valve housing.

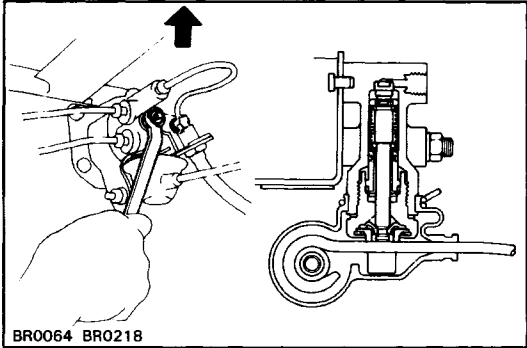

**6. IF NECESSARY, CHECK VALVE BODY**

- (a) Assemble the valve body in the uppermost position.  
 HINT: When the brakes are applied, the piston will move down about 1 mm (0.04 in.). Even at this time, the piston should not make contact with or move the load sensing spring.

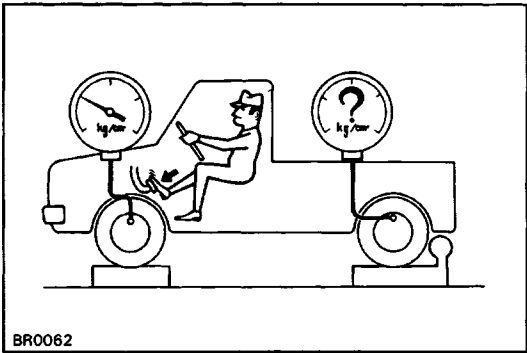

- (b) In this position, check the rear brake pressure.

2WD (SRW)

kPa (kgf/cm<sup>2</sup>, psi)

Front brake pressure	Rear brake pressure
490 (5, 71)	490 (5, 71)
2,452 (25, 356)	883 – 1,275 (9 – 13, 128 – 185)
5,884 (60, 853)	1,765 – 2,452 (18 – 25, 256 – 356)

4WD (DRW)

kPa (kgf/cm<sup>2</sup>, psi)

Front brake pressure	Rear brake pressure
490 (5, 71)	490 (5, 71)
2,452 (25, 356)	1,020 – 1,412 (10.4 – 14.4, 148 – 205)
5,884 (60, 853)	2,148 – 2,834 (21.9 – 28.9, 311 – 411)

4WD (Regular cab)

kPa (kgf/cm<sup>2</sup>, psi)

Front brake pressure	Rear brake pressure
981 (10, 142)	981 (10, 142)
2,452 (25, 356)	1,079 – 1,471 (11 – 15, 156 – 213)
5,884 (60, 853)	1,618 – 2,305 (16.5 – 23.5, 235 – 334)

4WD (Extra cab)

kPa (kgf/cm<sup>2</sup>, psi)

Front brake pressure	Rear brake pressure
981 (10, 142)	981 (10, 142)
2,452 (25, 356)	1,157 – 1,549 (11.8 – 15.8, 168 – 225)
5,884 (60, 853)	1,863 – 2,550 (19 – 26, 270 – 370)

If the measured value is not within standard, replace the valve body.

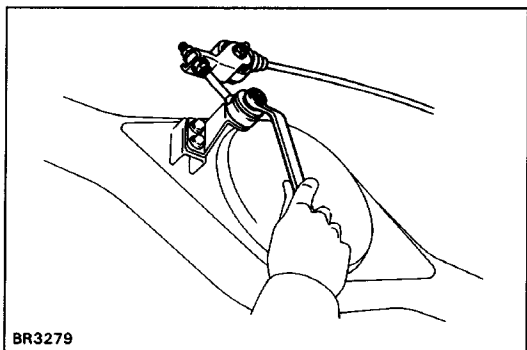

## REMOVAL OF LSP & BV OR LSPV

(See page BR-64)

### 1. DISCONNECT SHACKLE NO.2 FROM BRACKET

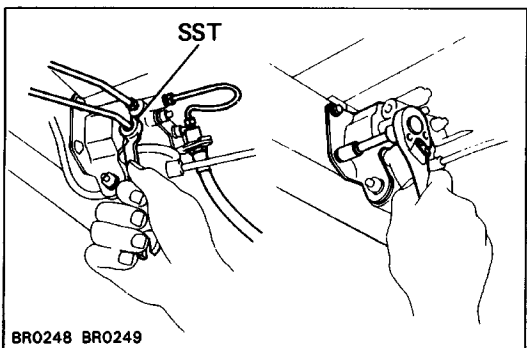

### 2. REMOVE LSP & BV (LSPV) ASSEMBLY

(a) Using SST, disconnect the brake tube from the valve body.

SST 09751-36011

(b) Remove the valve bracket mounting bolts and remove the LSP & BV (LSPV) assembly.

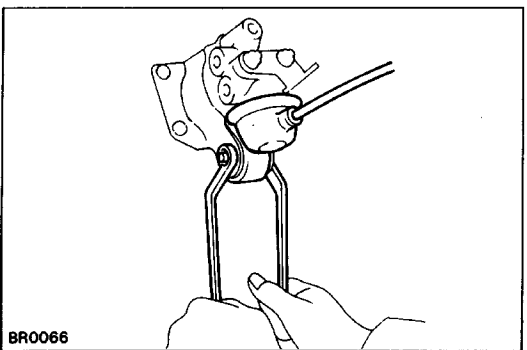

## DISASSEMBLY OF LSP & BV OR LSPV ASSEMBLY

### 1. REMOVE VALVE BRACKET

(a) Remove the nut and bolt as shown.

(b) Remove the two nuts, and remove the bracket and set plate from the valve body.

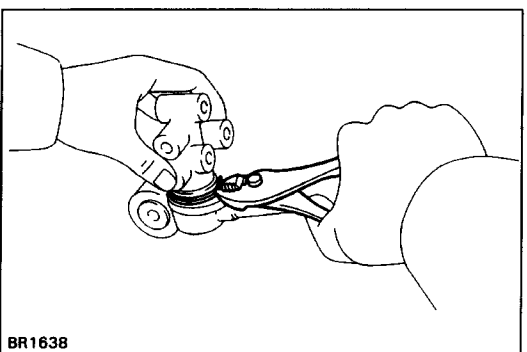

### 2. DISCONNECT SPRING FROM VALVE

Using pliers, remove the clip, and remove the spring from the valve.

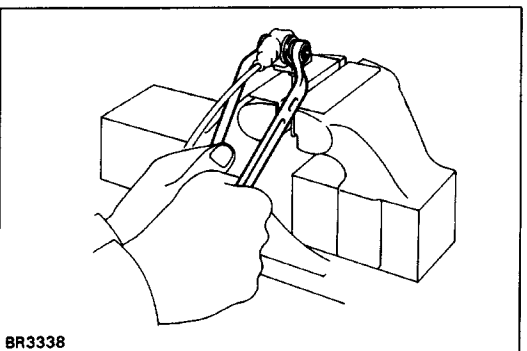

### 3. REMOVE SHACKLE NO. 1 AND NO.2

Remove the nut and bolt, and then remove the shackle No.1 and No.2, and two plate washers from the load sensing spring assembly.

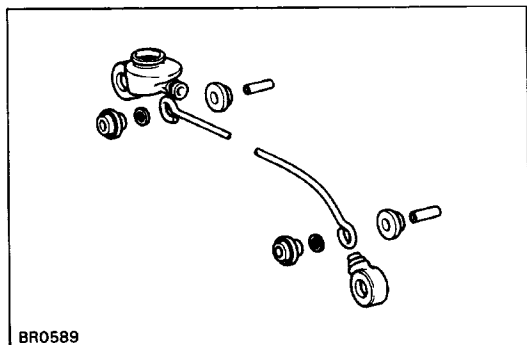

#### 4. DISASSEMBLE LOAD SENSING SPRING

Disassemble the following parts.

- (a) Bushings
- (b) Collars
- (c) Rubber plates
- (d) Load sensing valve boot
- (e) Load sensing spring boot

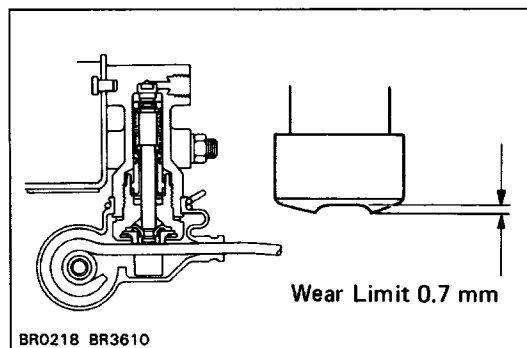

#### INSPECTION OF LSP & BV OR LSPV

INSPECT VALVE PISTON PIN AND LOAD SENSING CONTACT SURFACE FOR WEAR

Wear limit: 0.7 mm (0.028 in.)

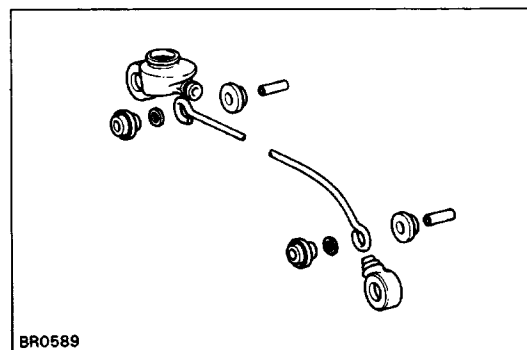

#### ASSEMBLY OF LSP & BV OR LSPV

(See page [BR-64](#))

##### 1. ASSEMBLE FOLLOWING PARTS TO LOAD SENSING SPRING:

- (a) Load sensing valve boot
- (b) Load sensing spring boot
- (c) Bushings
- (d) Rubber plates
- (e) Collars

HINT: Apply lithium soap glycol grease to all rubbing areas.

Do not mistake the valve side for the shackle side of the load sensing spring.

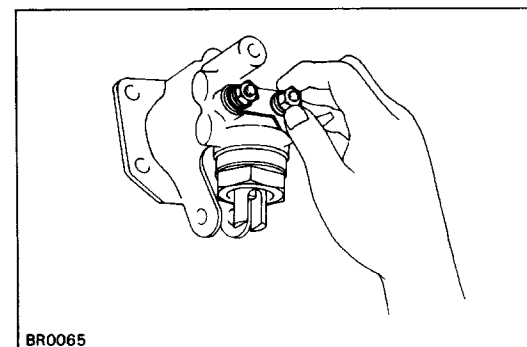
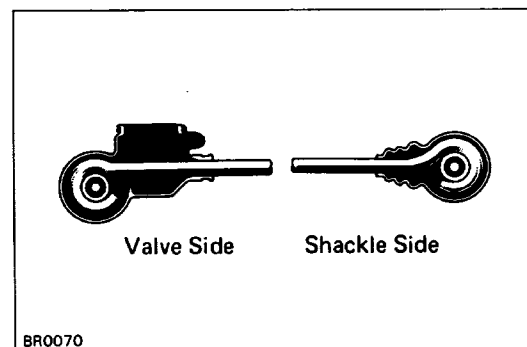

##### 2. ASSEMBLE VALVE BODY TO BRACKET

Assemble the valve body to the valve body bracket.

HINT: Finger tighten the valve body mounting nuts.

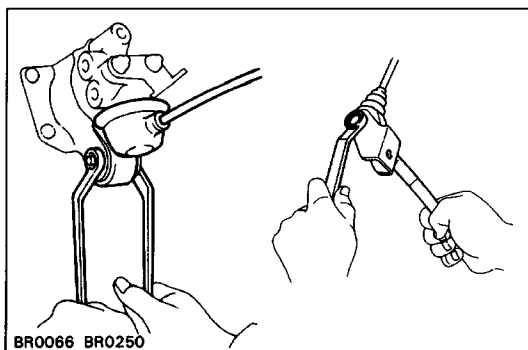

### 3. CONNECT VALVE BODY AND NO. 1 SHACKLE TO LOAD SENSING SPRING

**CAUTION:** When connecting the shackle to the load sensing spring with a bolt and nut, insert the bolt from the front side of vehicle.

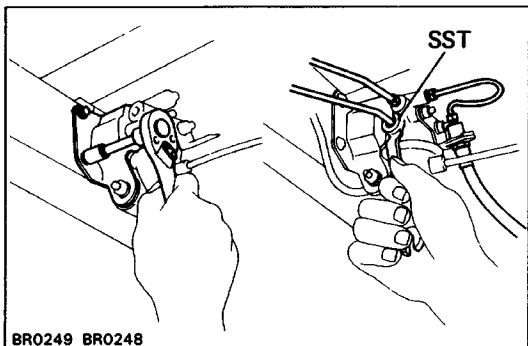

### INSTALLATION OF LSPV & BV OR LSPV

#### 1. INSTALL LSP & BV (LSPV) ASSEMBLY TO FRAME

Torque: 19 N-m (195 kgf-cm, 14 ft-lbf)

#### 2. CONNECT BRAKE TUBE

Using SST, connect the brake tubes.

Torque: 15 N-m (155 kgf-cm, 11 ft-lbf)

SST 09751-36011

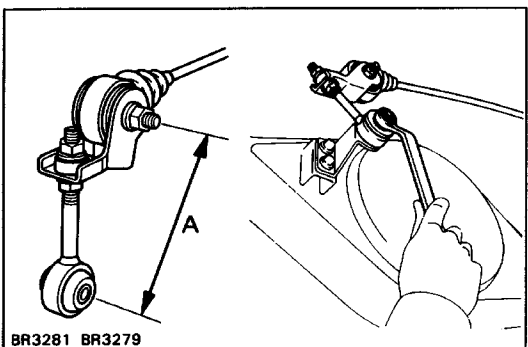

#### 3. CONNECT SHACKLE NO.2 BRACKET

(a) Install the shackle No.2 to the load sensing spring.

(b) Set dimension A.

Initial set: 2WD 78 mm (3.07 in.)

4WD 120 mm (4.72 in.)

(c) Connect the shackle No.2 to the shackle bracket.

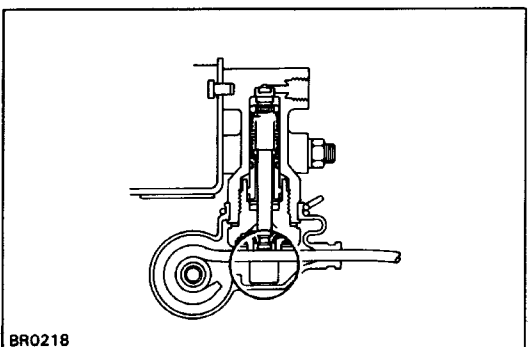

#### 4. SET REAR AXLE LOAD (See page BR-64)

#### 5. SET VALVE BODY

(a) When pulling down the load sensing spring, confirm that the valve piston moves down smoothly.

(b) Position the valve body so that the valve piston lightly contacts load sensing spring.

(c) Tighten the valve body mounting nuts.

#### 6. BLEED BRAKE LINE (See page BR-8)

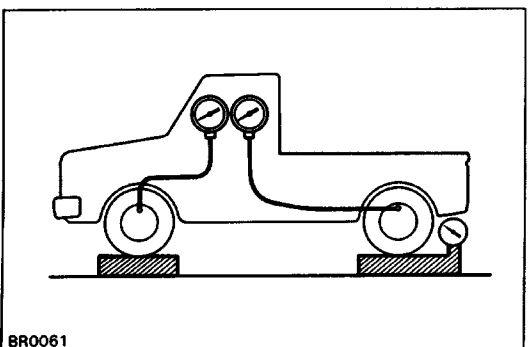

#### 7. CHECK AND ADJUST LSP & BV OR (LSPV) FLUID PRESSURE

(See page BR-64)

#### 8. APPLY SEALANT TO SHACKLE NO.2

Apply sealant to the top portion of the shackle No.2 bolt threads not to lose the upper lock nut.

Sealant: Part No. 08833-00070, THREE BOND 1324 or equivalent

# REAR-WHEEL ANTI-LOCK BRAKE SYSTEM

## General Description

- The Rear-Wheel Anti-Lock Brake System is a brake system which controls the wheel cylinder hydraulic pressure of the rear wheels during sudden braking and braking on slippery road surfaces, preventing the rear wheels from locking.
- In case a malfunction occurs, a diagnosis function and fail-safe system have been adopted for the Rear-Wheel Anti-Lock Brake System to increase serviceability.

## LOCATION OF SYSTEM COMPONENTS

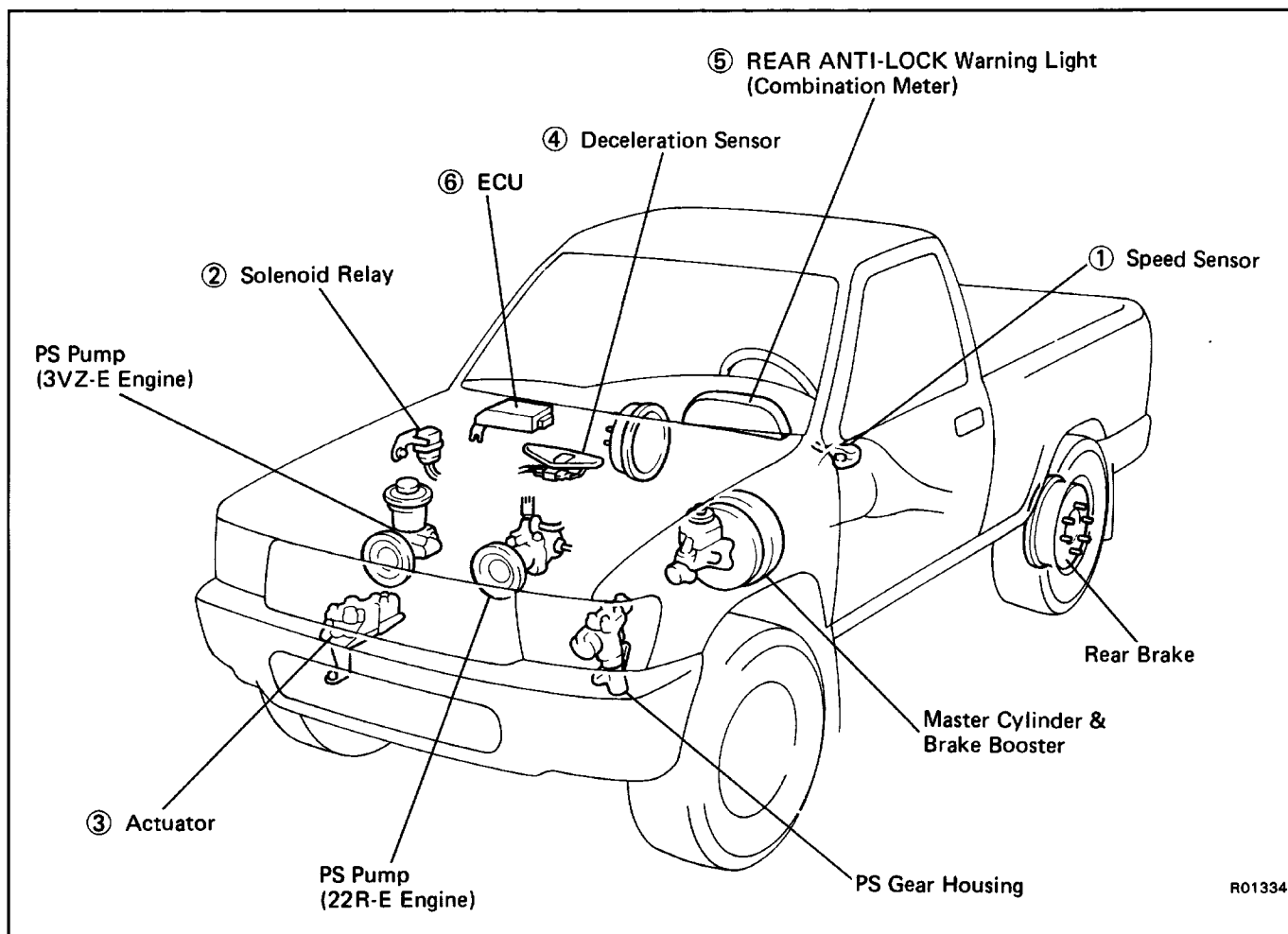

## FUNCTION OF COMPONENTS

No.	Components	Function
1	Speed Sensor	Detects the wheel speed from the rotation of the rear differential ring gear.
2	Solenoid Relay	Supplies electric current to the solenoid valve of the actuator.
3	Actuator	Controls the brake fluid pressure to rear brake wheel cylinders through signals from the ECU.
4	Deceleration Sensor	Detects the vehicle deceleration rate from the deceleration of the body.
5	REAR ANTI-LOCK Warning Light	Lights up to alert the driver when trouble has occurred in the Rear-wheel Anti-Lock Brake System.
6	ECU	According the wheel speed signals from the speed sensor and vehicle deceleration signals from the deceleration sensor, it calculates acceleration, deceleration and slip values and sends signals to the actuator to control brake fluid pressure.

# WIRING DIAGRAM

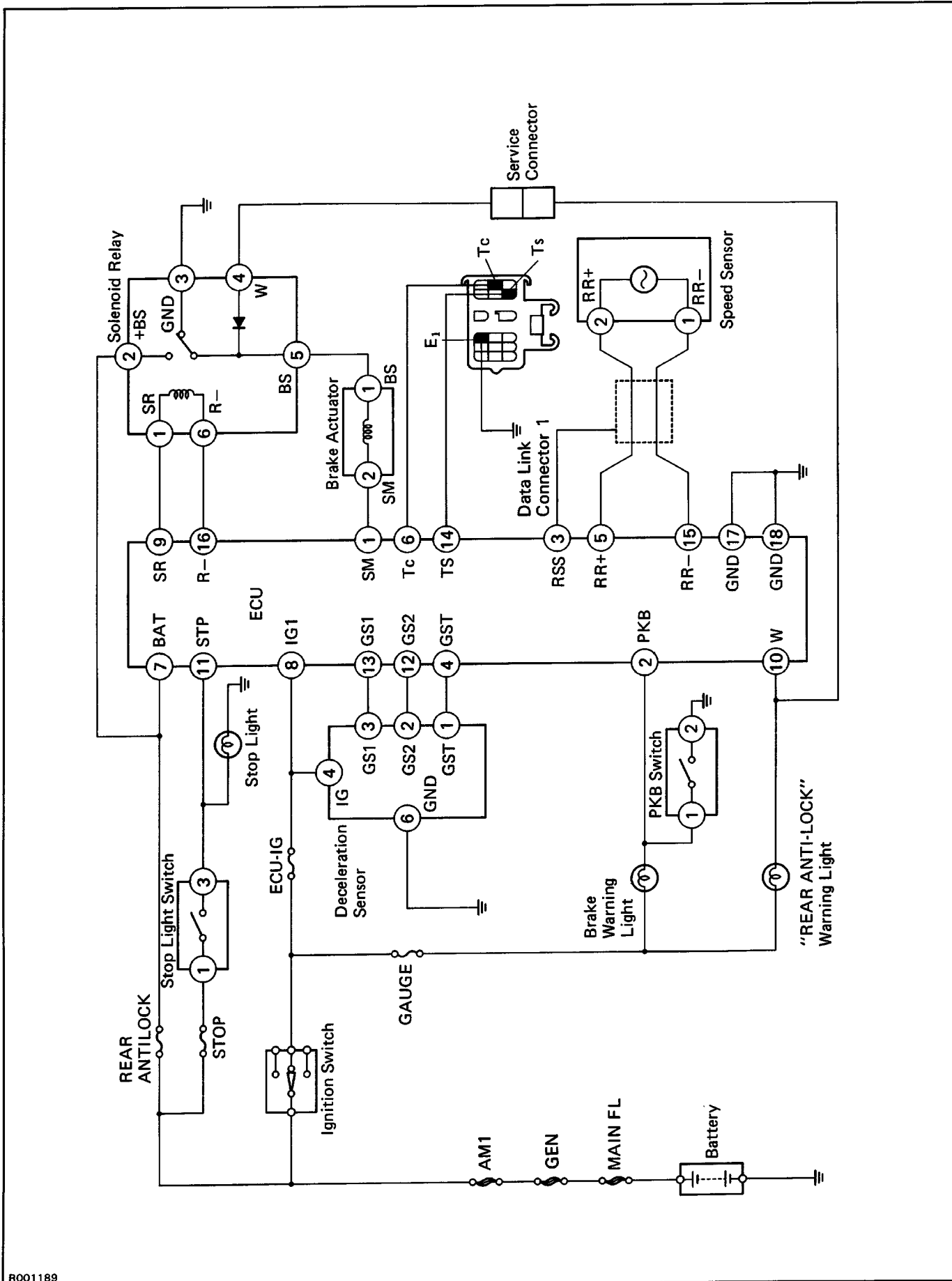



# CONNECTORS

Stop Light Switch

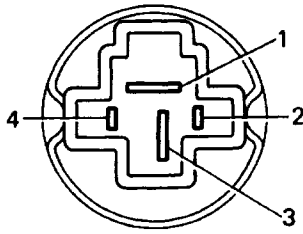

Solenoid Relay

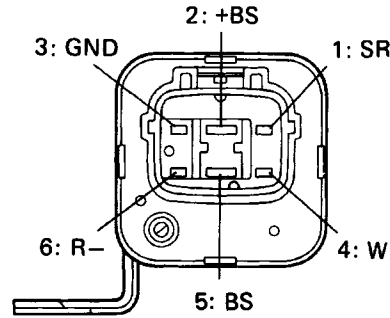

Brake Actuator

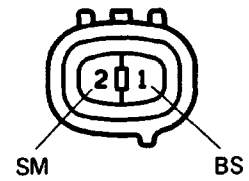

Deceleration Sensor

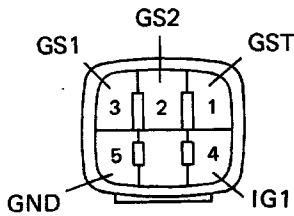

Parking Brake Switch

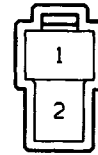

Data Link Connector 1

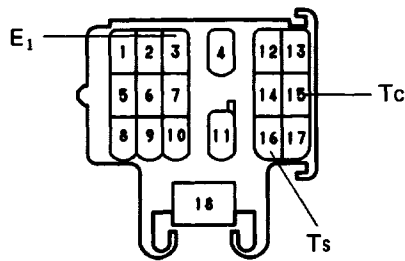

Service Connector



(Solenoid Relay Side)

Speed Sensor

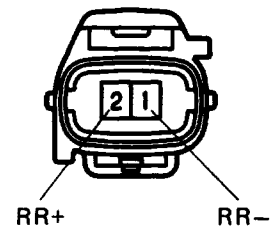

Rear-Wheel Anti-Lock Brake System ECU

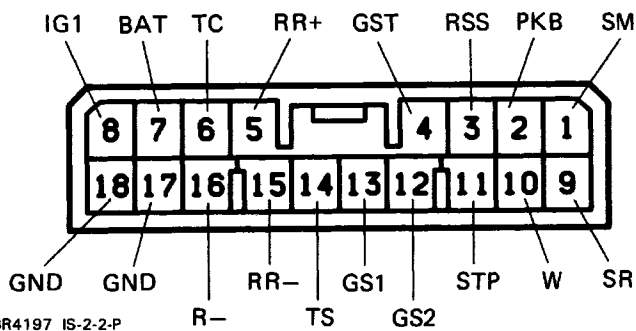

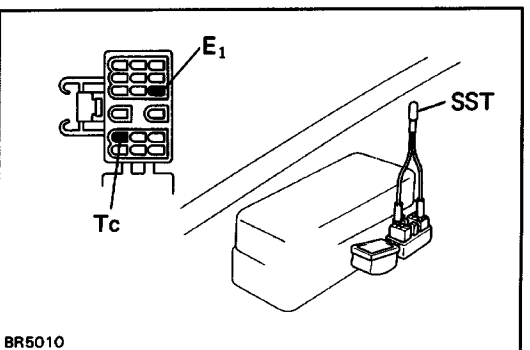
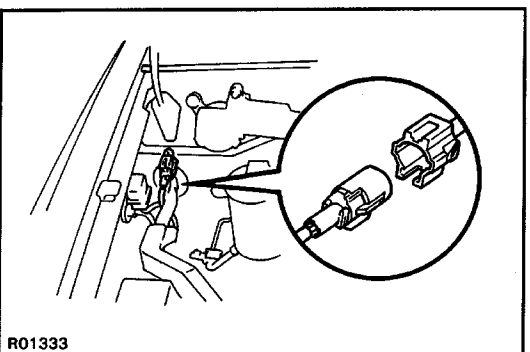
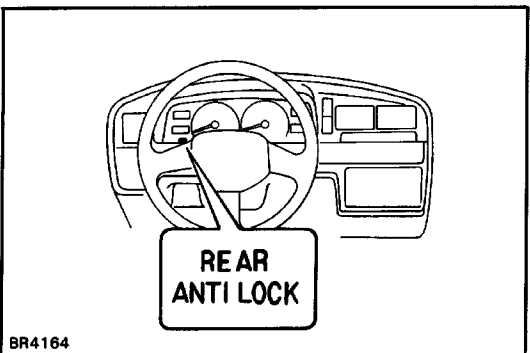
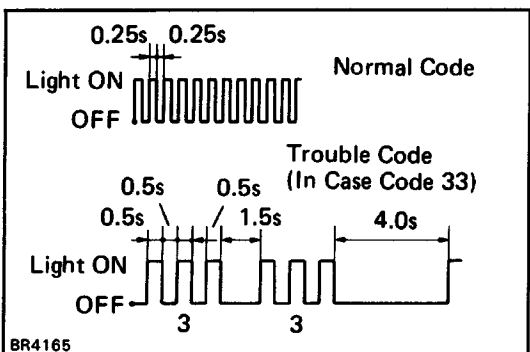
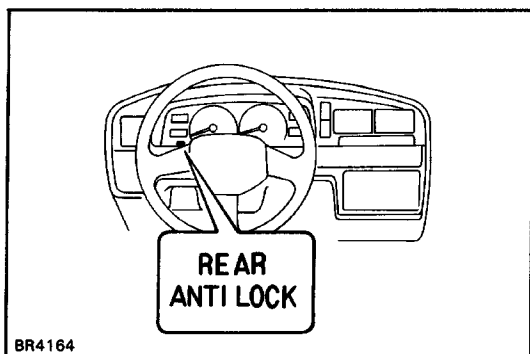

## Diagnosis System

### DESCRIPTION

If a functional malfunction occurs, diagnosis system will identify the problem and ECU stores the codes for the trouble items.

At the same time, the system informs the driver of a malfunction via the "REAR ANTILOCK" warning light in the combination meter.

By turning on the ignition switch and disconnecting the service connector, the trouble can be identified by the number of blinks (diagnosis code) of the warning light. In event of two codes, that having the smallest number (code) will be identified first.

HINT: The warning light do not show the diagnostic trouble codes while the vehicle is running.

### INSPECTION OF DIAGNOSIS SYSTEM

#### 1. INSPECT BATTERY POSITIVE VOLTAGE

Inspect that the battery positive voltage is about 12 V.

#### 2. CHECK THAT WARNING LIGHT TURNS ON

- Turn the ignition switch to ON.
- Check that the "REAR ANTILOCK" warning light turns on for about 3 seconds.  
If not, inspect and repair or replace the fuse, bulb and wire harness.

#### 3. READ DIAGNOSTIC TROUBLE CODE

- Turn the ignition switch to ON.
- Disconnect the service connector.  
SST 09843-18020
- Using SST, connect the terminal Tc to E<sub>1</sub> of the data link connector 1.

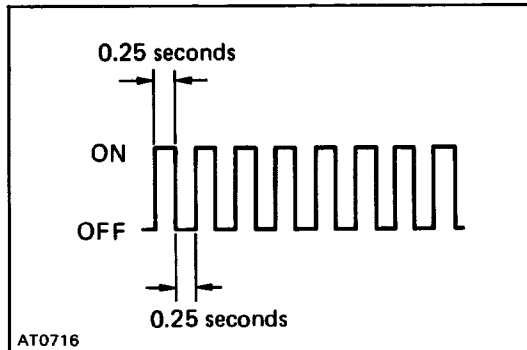
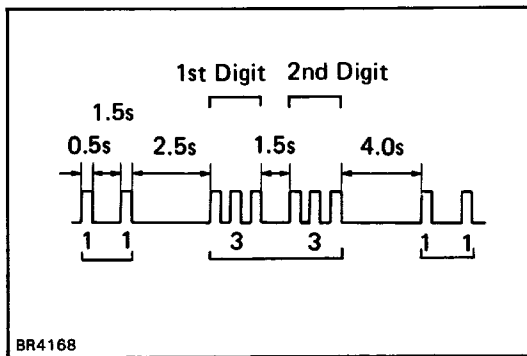







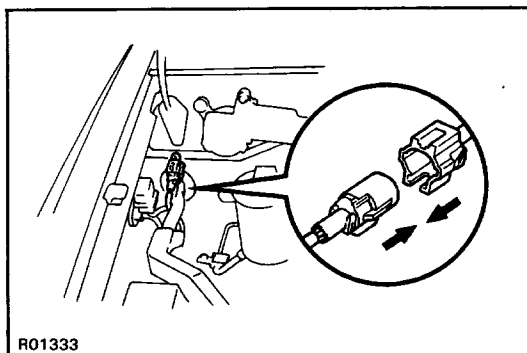

- (d) In event of a malfunction, 4 seconds later the warning light will begin to blink. Read the number of blinks.  
(See DIAGNOSTIC TROUBLE CODE on page [BR-75](#))  
HINT: The first number of blinks will equal the first digit of a two digit diagnostic trouble code. After a 1.5 seconds pause, the 2nd number of blinks will equal the 2nd number of a two digit code. If there are two or more codes, there will be a 2.5 seconds pause between each, and indication will begin after 4.0 seconds pause from the smaller value and continue in order to larger.
- (e) If the system is operating normally (no malfunction), the warning light will blink 2 times per second.

- (f) Repair the malfunctioning parts.
- (g) After the malfunctioning parts has been repaired, clear the diagnostic trouble codes stored in the ECU .  
(See page [BR-76](#))  
HINT: If you disconnect the battery cable while repairing, all diagnostic trouble codes in the ECU will be erased.
- (h) Disconnect the terminal Tc from E1 of the data link connector 1.

- (i) Connect the service connector.  
Turn the ignition switch to ON, and check that the "REAR ANTILOCK" warning light goes off after the warning light goes on for about 2 seconds.



## DIAGNOSTIC TROUBLE CODE

Code No.	Light Pattern	Diagnosis	Trouble Part
11	ON OFF 	Open circuit in solenoid relay circuit or solenoid circuit	<ul style="list-style-type: none"> <li>• Solenoid</li> <li>• Solenoid relay</li> <li>• Wire harness and connector of solenoid and/or solenoid relay circuit</li> </ul>
12		Short circuit in solenoid relay circuit	
25		Short circuit in solenoid circuit	
33		Open or short circuit in speed sensor circuit	<ul style="list-style-type: none"> <li>• Speed sensor</li> <li>• Wire harness and connector of speed sensor circuit</li> </ul>
41		Low battery positive voltage (9.5 V or lower)	<ul style="list-style-type: none"> <li>• Battery</li> </ul>
42		Abnormally high battery positive voltage (17 V or higher)	
43		Mechanical malfunction in deceleration sensor	<ul style="list-style-type: none"> <li>• Deceleration sensor</li> <li>• Wire harness and connector of deceleration sensor circuit</li> </ul>
44		Electrical malfunction in deceleration sensor circuit	
Always ON		Malfunction in ECU	<ul style="list-style-type: none"> <li>• ECU</li> </ul>

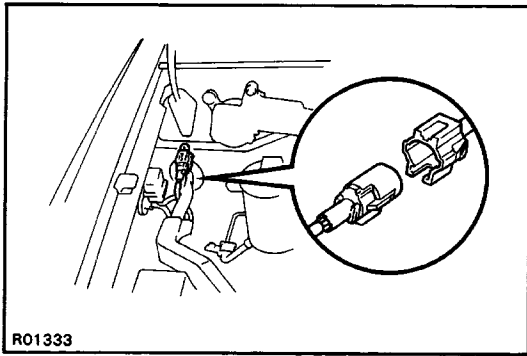

R01333

## CLEARING OF DIAGNOSTIC TROUBLE CODES

### CLEAR DIAGNOSTIC TROUBLE CODES

- (a) Turn the ignition switch to ON.  
 (b) Disconnect the service connector.  
 HINT: Keep the vehicle stopped (vehicle speed 0 km/h (0 mph)).

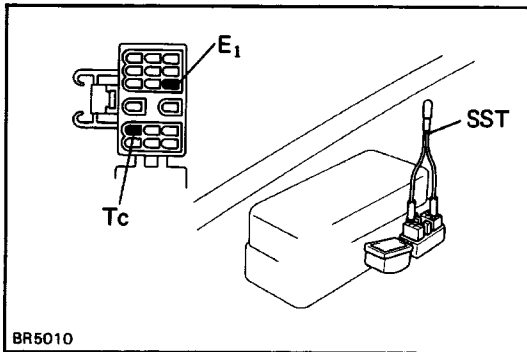

BR5010

- (c) Using SST, connect the terminal Tc to E<sub>1</sub> of the data link connector 1.

SST 09843-18020

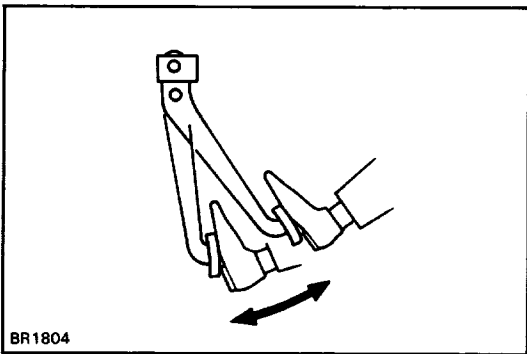

BR1804

- (d) Clear the diagnostic trouble codes stored in ECU by depressing the brake pedal 8 or more times within 3 seconds.

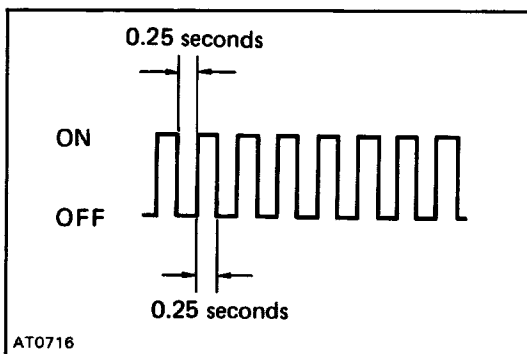

AT0716

- (e) Check that the warning light shows the -normal code.  
 If the warning light still shows the diagnostic trouble codes, check for cause and repair or replace the trouble parts, then clear the diagnostic trouble codes again.

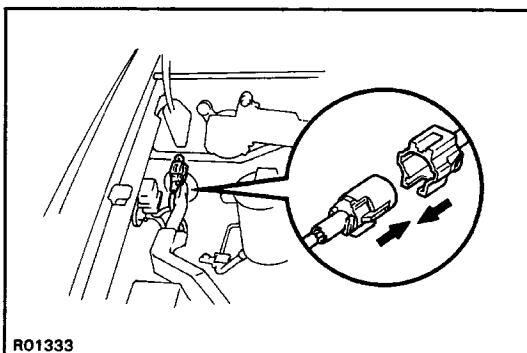

R01333

- (f) Connect the service connector.  
 (g) Disconnect the terminal Tc from E<sub>1</sub> of the data link connector 1.

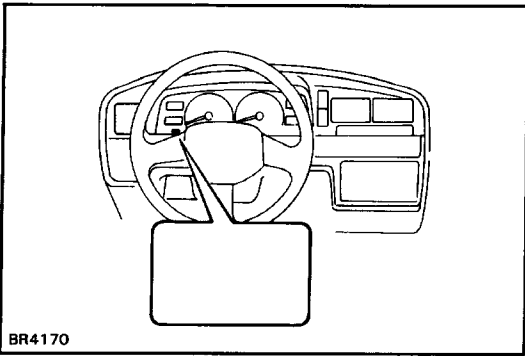

BR4170

(h) Check that the warning light goes off.

## Troubleshooting

Problem		No.
"REAR ANTILOCK" warning light	Always comes on after ignition switch is turned to ON.	1
	Does not come on for about 3 seconds after ignition switch on.	2
	Comes on and off.	3
	Comes on while running.	1
Brake working	Brakes pull.	4
	Braking inefficient.	4
	Rear-Wheel Anti-Lock Brake System operates at ordinary braking.	4
	Rear-Wheel Anti-Lock Brake System operates just before stopping at ordinary braking.	4
	Brake pedal pulsates abnormally while Rear-Wheel Anti-Lock Brake System is operating.	4
	Skidding noise occurs while Rear-Wheel Anti-Lock Brake System working. (Rear-Wheel Anti-Lock Brake System works inefficiently)	5

### 1 "REAR ANTILOCK" warning light comes on.

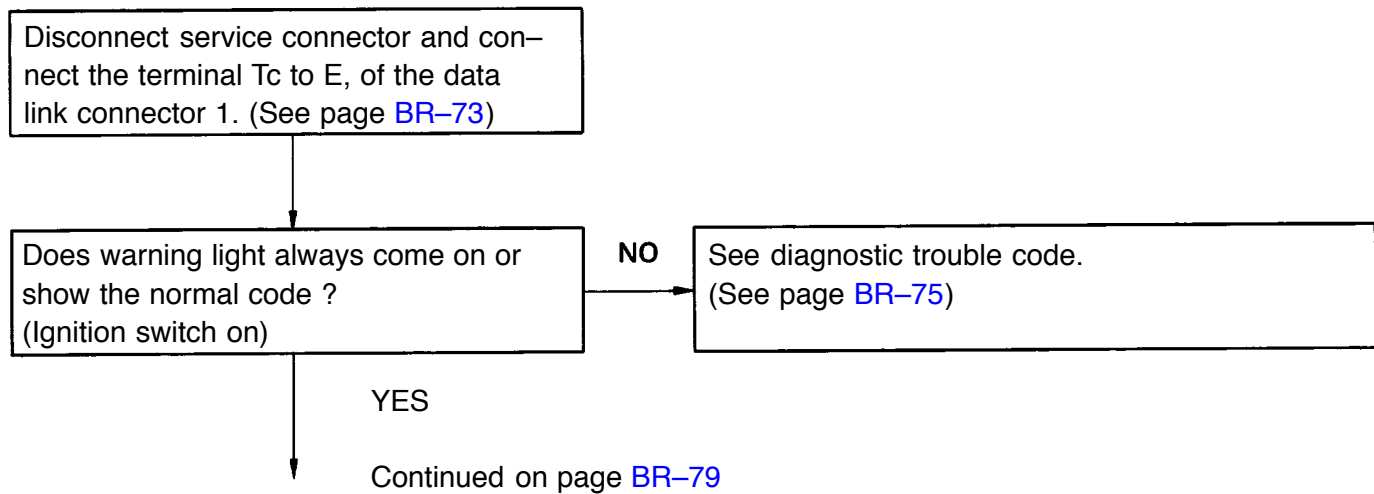

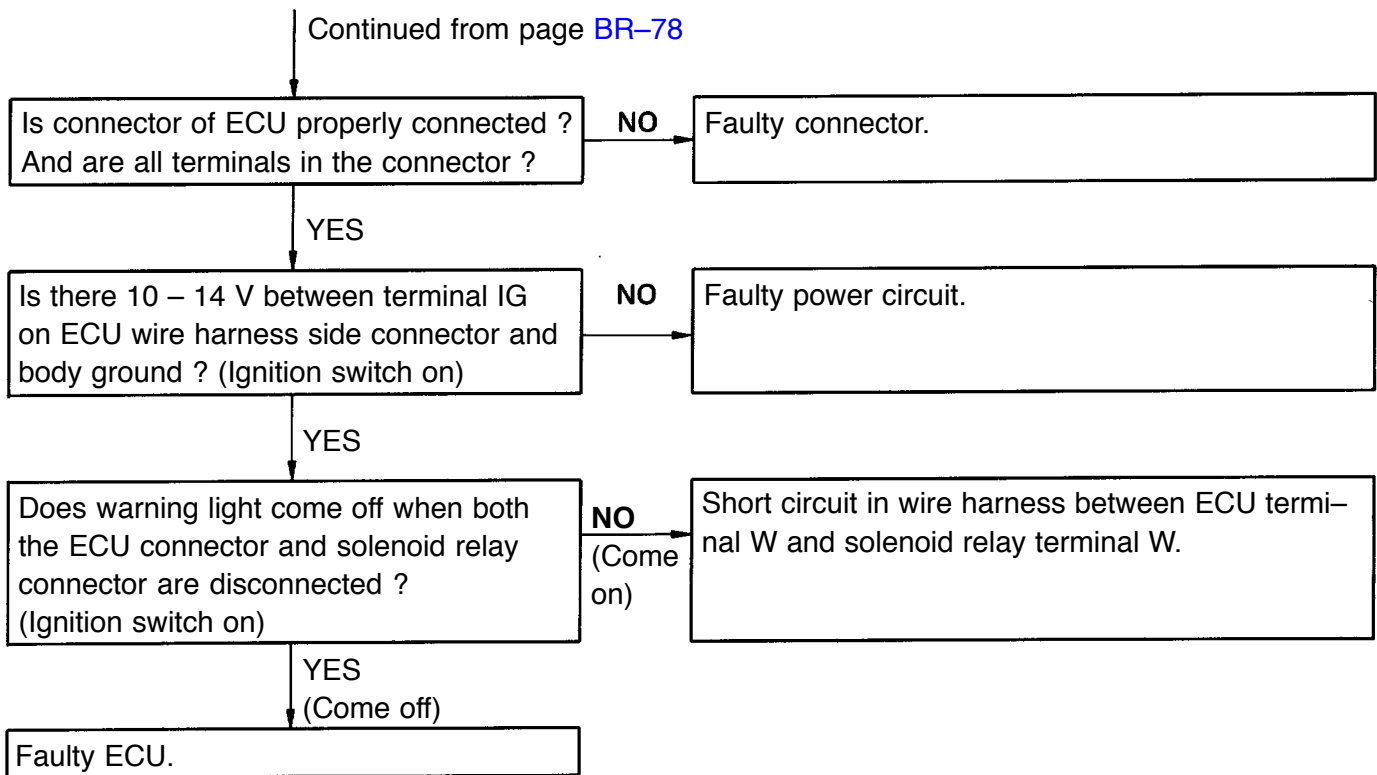



2

**"REAR ANTILOCK" warning light does not come on for about 2 seconds after ignition switch on.**

Disconnect service connector and ground the terminal W of the wire harness side connector. (Ignition switch on)

Does warning light come on ?

NO

Bulb burned out or open circuit in wire harness between warning light and service connector terminal W.

YES

Disconnect connector from ECU and solenoid relay, and ground terminal W of ECU wire harness side connector. (ignition switch on)

Does warning light come on ?

NO

Open circuit in wire harness between ECU terminal W and warning light.

YES

With ignition switch off, disconnect solenoid relay connector, and check continuity between terminal W and BS on solenoid relay side.

Reverse tester leads and check again. Is there one way continuity between terminals ?

NO

Short circuit in solenoid relay inside diode.

YES

Faulty ECU.

HINT: If the diode is short-circuited, a malfunction at ECU terminal W will occur.

When inspecting the terminal, connect the ECU connector and disconnect solenoid relay connector. Then turn the ignition switch on, and check that the warning light goes on. If it does, the ECU terminal is OK.

### 3 "REAR ANTILOCK" warning light comes on and off .

- Short circuit in wire harness between ECU terminal TS and data link connector 1 terminal Ts.
- Short circuit in wire harness between ECU terminal TC and data link connector 1 terminal Tc.

4

- **Braking inefficient.**
- **Rear-Wheel Anti-Lock Brake System operates at ordinary braking.**
- **Rear-Wheel Anti-Lock Brake System operates just before stopping at ordinary braking.**
- **Brake pedal pulsates abnormally while Rear-Wheel Anti-Lock Brake System working.**

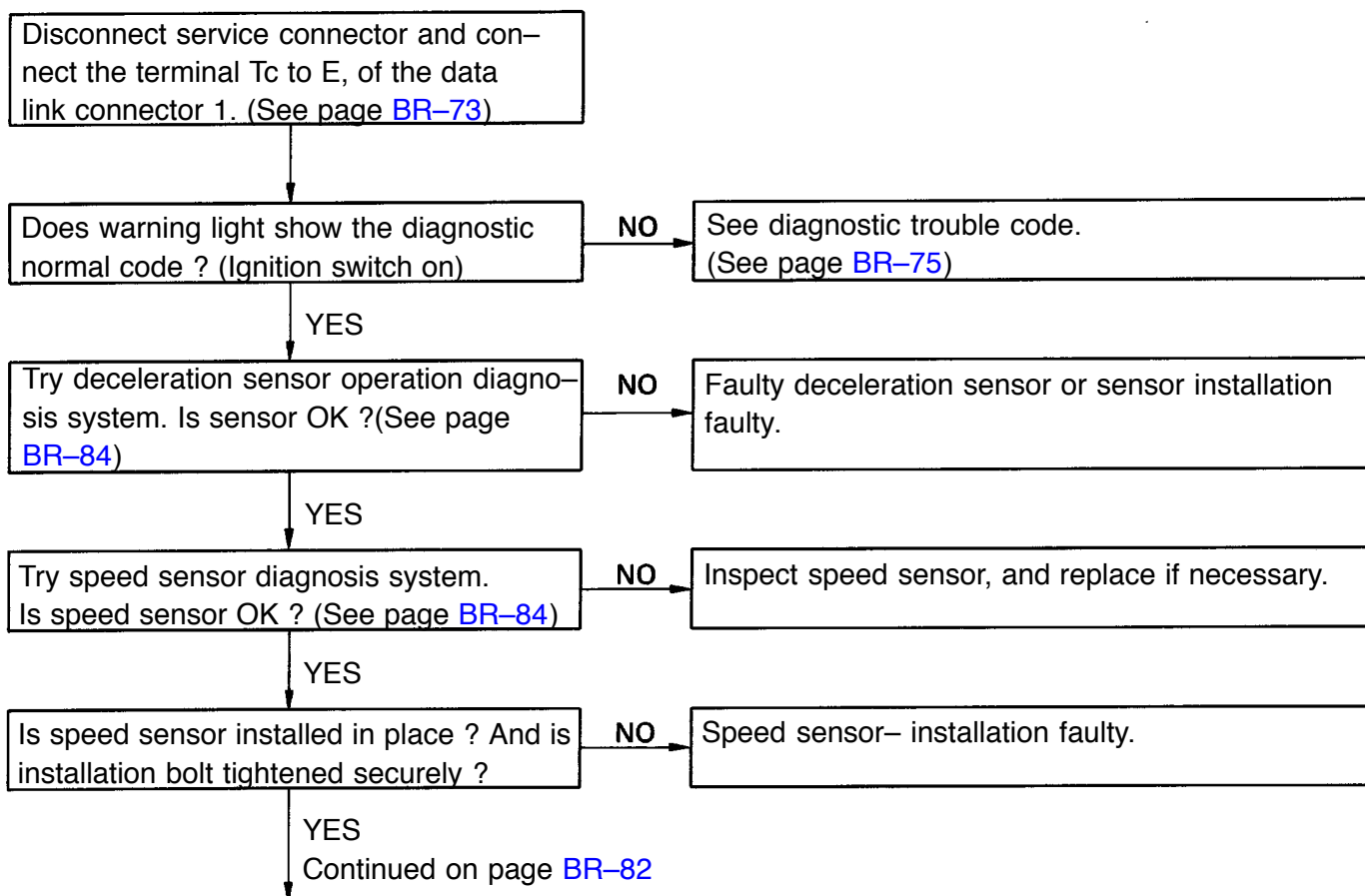

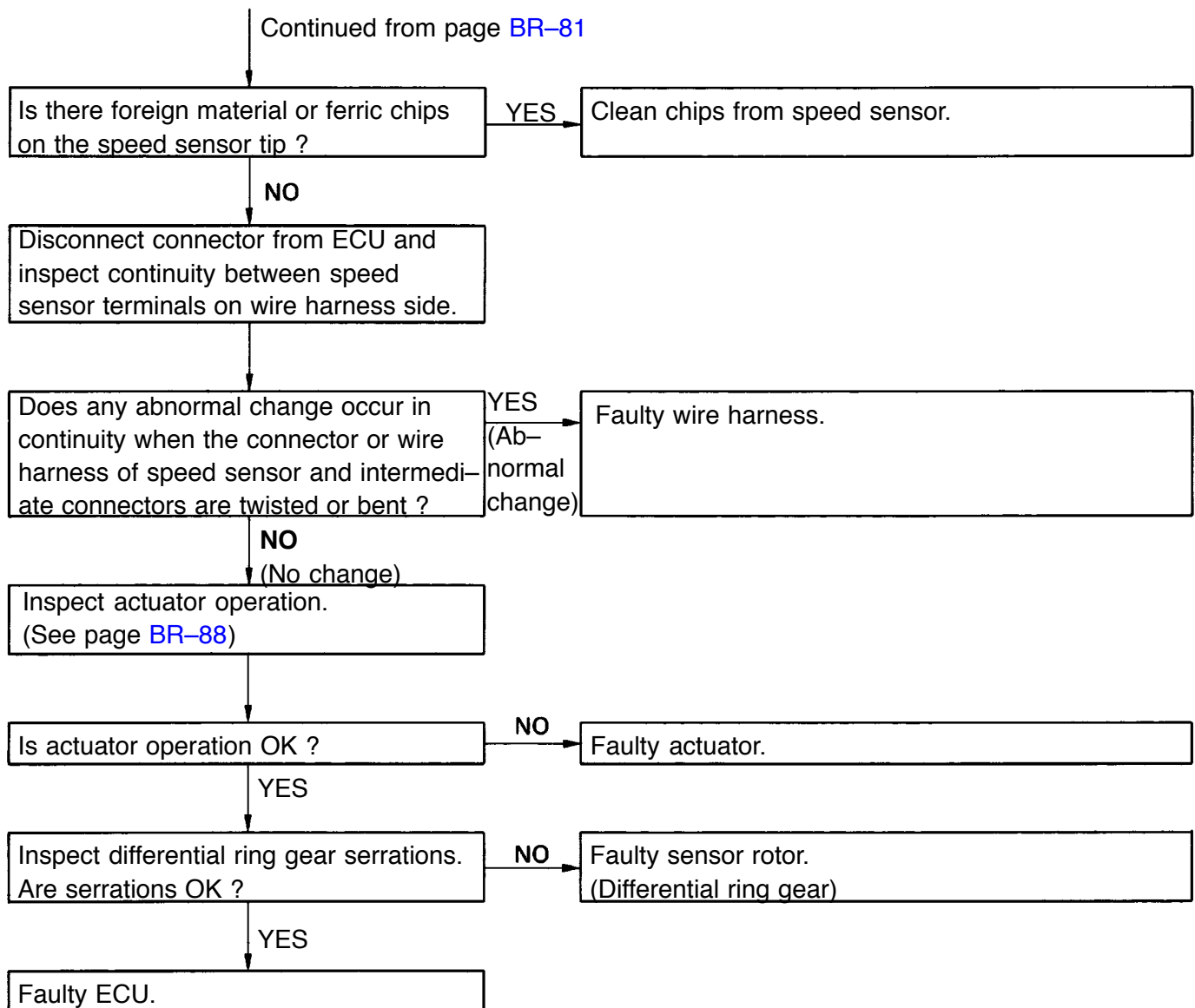

**5 Rear-Wheel Anti-Lock Brake System works inefficiently.**

Disconnect service connector and connect the terminal Tc to E , of the data link connector

1. (See page [BR-73](#))

Does warning light show the diagnostic normal code ?  
(Ignition switch on)

NO

See diagnostic trouble code.  
(See page [BR-75](#))

YES

Is there battery positive voltage between ECU terminal STP and body ground when depressing brake pedal ?

NO

Open circuit in stop light switch and/or wire harness.

YES

Inspect actuator.  
(See page [BR-87](#))

## Deceleration Sensor and Speed Sensor Diagnosis System

### PRECAUTION

- While checking the deceleration sensor and speed sensor diagnosis system, the Rear-Wheel Anti-Lock Brake System does not work and brake system works as normal brake system.

### INSPECTION OF DIAGNOSIS SYSTEM

#### 1. INSPECT BATTERY POSITIVE VOLTAGE

Inspect that the battery positive voltage is about 12 V.

#### 2. CHECK THAT WARNING LIGHT TURNS ON

- Turn the ignition switch to ON.
- Check that the "REAR ANTI-LOCK" warning light turns on for about 3 seconds.  
If not, inspect and repair or replace the fuse, bulb and wire harness.
- Check that the "REAR ANTI-LOCK" warning light turns off.
- Turn the ignition switch to OFF.

#### 3. PERFORM FOLLOWING STEPS

- Using SST, connect the terminal Ts to E1 of the data link connector 1.  
SST 09843-18020
- Start the engine.

- (2 WD model)

Check that the warning light blinks about 4 times every 1 second after blinking 1 time in 1.5 seconds as shown.

- (4 WD model)

Check that the warning light blinks about 4 times every 1 second after blinking 2 times in 2.0 seconds as shown.

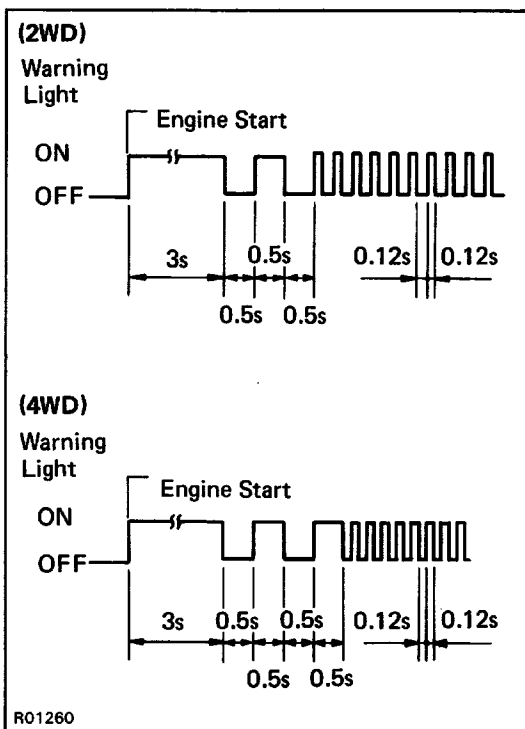
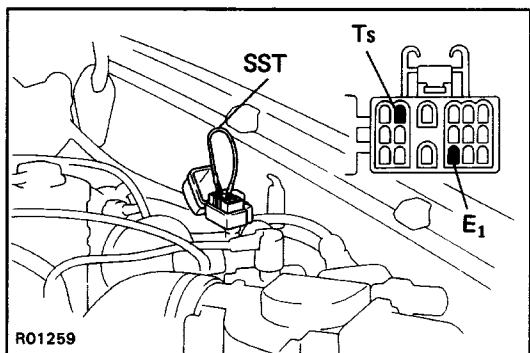
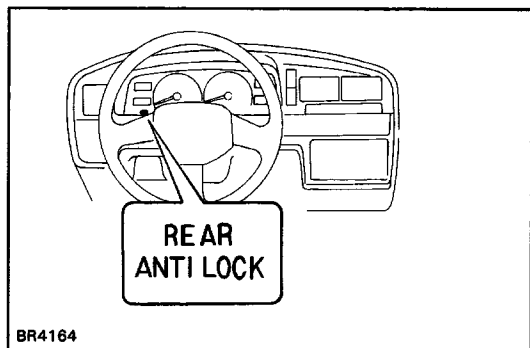

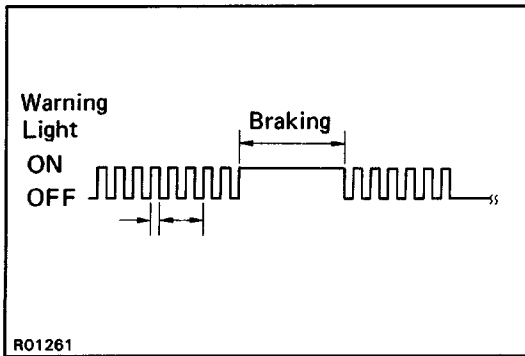

- (e) Drive the vehicle straight ahead at about 20 km/h (12.4 mph) or more, depress the brake pedal strongly.
- (f) Check that the warning light turns on while braking.

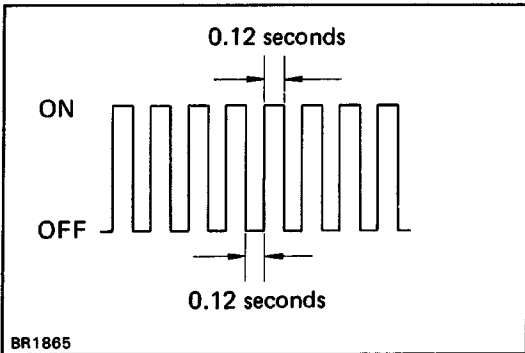

- (g) Drive the vehicle straight ahead at about 50 km/h (31 mph) or more, and stop the vehicle.
- (h) Check that the warning light blinks about 4 times every 1 second as shown.

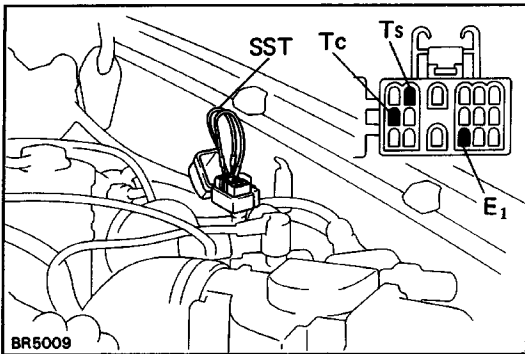

- (i) Using SST, connect terminals Tc and E 1 of the data link connector 1.  
SST 09843-18020

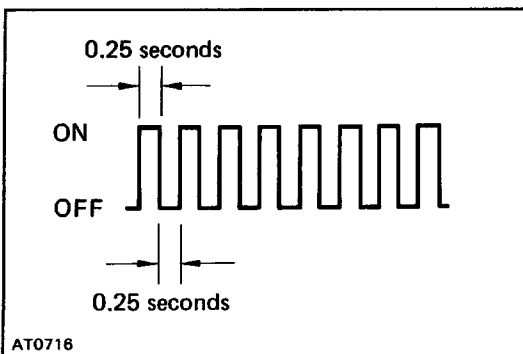

- (j) Check that the warning light shows the normal code.

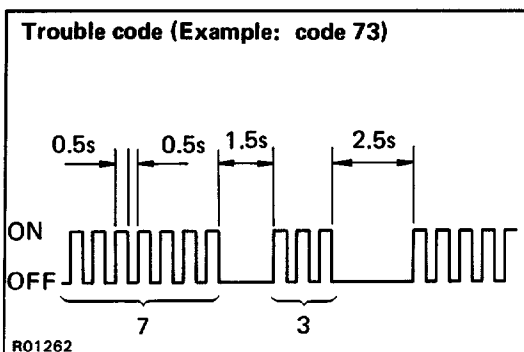

- (k) In event of a malfunction, 2.5 seconds later the warning light will begin to blink. Read the number of blinks.  
(See DIAGNOSTIC TROUBLE CODE on page BR-86)  
HINT: The first number of blinks will equal the first digit of a two digit diagnostic trouble code. After a 1.5 seconds pause, the 2nd number of blinks will equal the 2nd number of a two digit code. If there are two or more codes, there will be a 2.5 seconds pause between each, and indication will begin after 2.5 seconds pause from the smaller value and continue in order to larger.

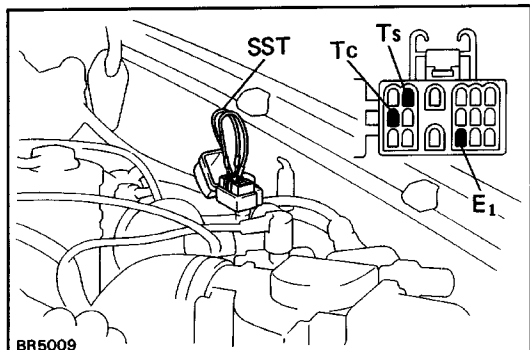
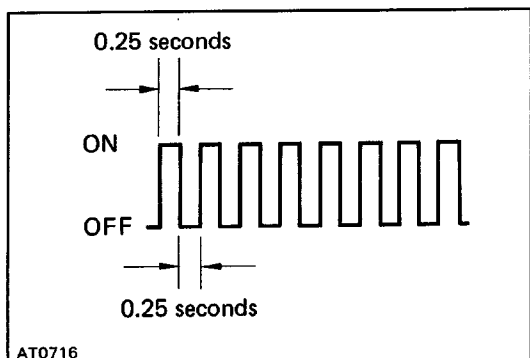

- (l) If the system is operating normally (no malfunction), the warning light will blink once every 0.5 seconds.
- (m) Repair the system.
- (n) After the malfunctioning components have been repaired, clear the diagnostic trouble codes stored in the ECU.  
(See page BR-76)  
HINT: If you disconnect the battery cable while repairing, all diagnostic trouble codes in the ECU will be erased.
- (o) Remove the SST from terminals Ts, Tc and E 1 of the data link connector 1.  
SST 09843-18020

## DIAGNOSTIC TROUBLE CODE

Code No.	Light Pattern	Diagnosis	Malfunctioning Part
	ON OFF	Speed sensor and sensor rotor are normal	
73		Low output voltage of speed sensor signal	Speed sensor Sensor rotor Differential ring gear
77		Abnormal change of output voltage of speed sensor signal	Sensor rotor Differential ring gear
79		Sticking of deceleration sensor pendulum	Deceleration sensor

## Brake Actuator COMPONENTS

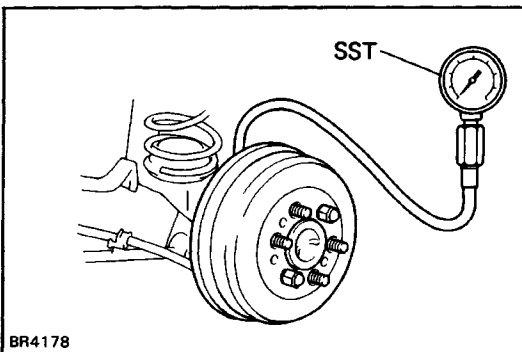
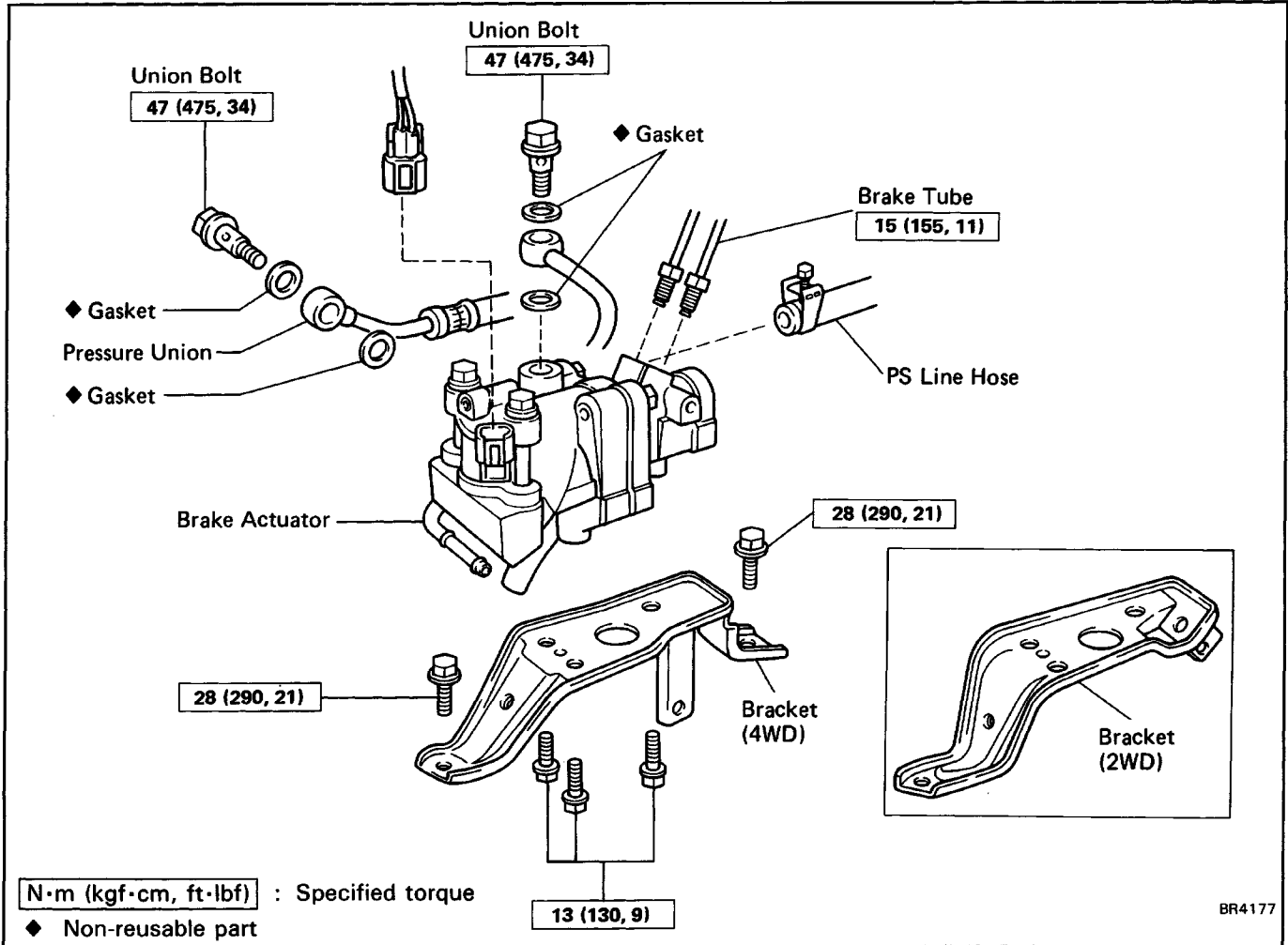

### INSPECTION OF BRAKE ACTUATOR

#### 1. CHECK BRAKE FLUID PRESSURE

(a) Remove the bleeder plug from the rear wheel cylinder and connect SST.

SST 09709-29017

(b) Bleed the air from SST.

1,961 kPa  
(20 kgf/cm<sup>2</sup>, 284 psi)

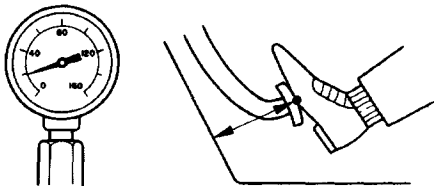

(c) With the engine off, hold the brake pedal depressed for about 10 seconds with the pressure at 1,961 kPa (20 kgf/cm<sup>2</sup>, 284 psi), and check that there is no change in the pedal reserve distance.

If there is a change in the brake pedal reserve distance, check the brake line, master cylinder and wheel cylinder for fluid leakage.



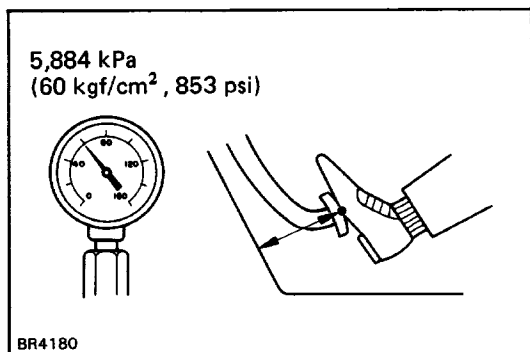

- (d) With the engine running, hold the brake pedal depressed for about 10 seconds with the pressure at 5,844 kPa (60 kgf/cm<sup>2</sup>, 853 psi), and check that there is no change in the pedal reserve distance. If there is a change in the brake pedal reserve distance, inspect the brake actuator.

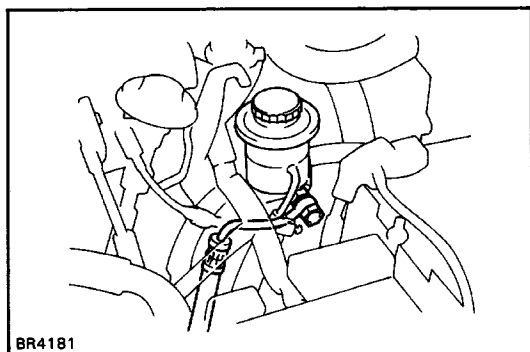

## 2. CHECK POWER STEERING FLUID PRESSURE

- (a) (4WD w/ 22R-E Engine)

Using SST, disconnect the power steering pressure line from the power steering pump.

SST 0963 1-22020

- (b) (Except 4WD w/ 22R-E Engine)

Remove the union bolt and disconnect the power steering pressure line from the power steering pump.

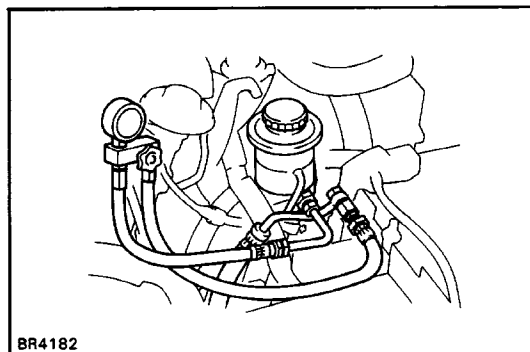

- (c) Connect the power steering pressure gauge between the power steering pump and hose with the gauge valve on the actuator side.
- (d) Bleed the system and check that the fluid level is correct.  
(See page [BR-94](#))

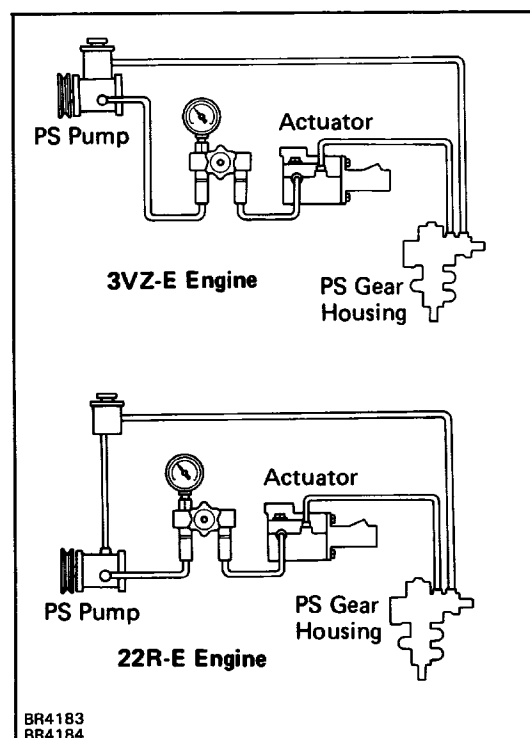

- (e) Start the engine and run it at idle.

- (f) Close the pressure gauge valve and observe the reading on the gauge.

**Minimum pressure: 7,355 kPa (75 kgf/cm<sup>2</sup>, 1,067 psi)**

HINT:

- Do not keep the valve closed for more than 10 seconds.
- Check with the fluid temperature at least 80°C (176°F).

If pressure is low, repair or replace the power steering pump.

## 3. CHECK RELATION BETWEEN BRAKE FLUID AND POWER STEERING FLUID PRESSURE

HINT:

- Be sure the tires in the straight-ahead position.
- Be sure the power steering pressure gauge valve is fully open.
- Check with the power steering fluid temperature at least 80°C (176°F).

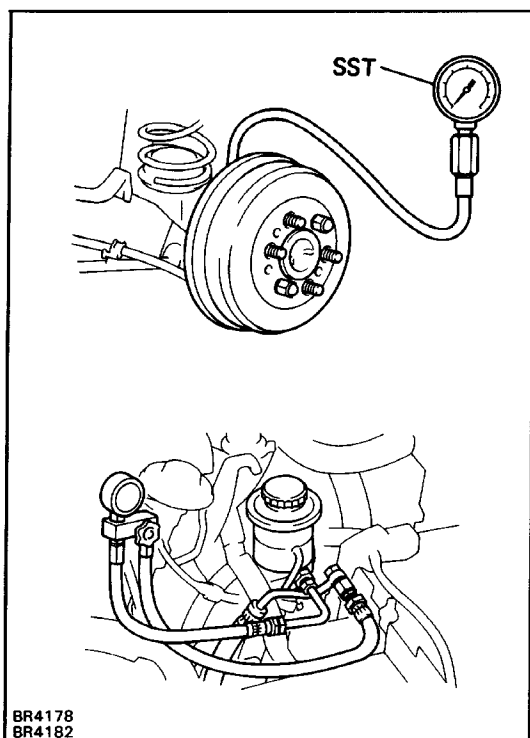

With the engine running, the brake and power steering fluid pressure should conform to the following table.

kPa (kgf/cm<sup>2</sup>, psi)

Brake Fluid Pressure	2,941 (30, 427)	9,807 (100, 1,422)
PS Fluid Pressure	1,569 - 2,550 (16 - 26, 228 - 370)	3,236 - 4,609 (33 - 47, 469 - 668)

If not within specification, check the actuator.

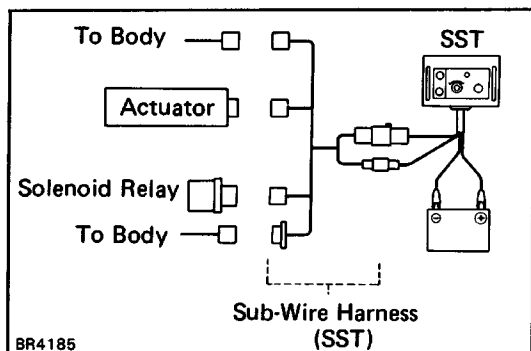

#### 4. CHECK ACTUATOR OPERATION

- Disconnect the connector from the actuator.
- Disconnect the connector from the solenoid relay.
- Connect the actuator checker (SST) to the actuator, solenoid relay and body side wire harness through the sub-wire harness (SST) as shown.  
SST 09990-00150 and 09990-00205
- Connect the red cable of the checker to the battery positive (+) terminal and black to the negative (-) terminal.
- Start the engine, and run it at idle.
- Turn the selector switch of actuator checker to "REAR" position.
- Strongly depress the brake pedal and hold it.
- Push the ON/OFF switch, and check that the brake pedal sinks a little and that it returns to the original position when the switch is released.

#### NOTICE:

- To avoid damaging the master cylinder piston cup, do not push on SST switch before depressing the brake pedal and do not release your foot from the brake pedal while SST switch is pushing on.
- Do not keep the ON/OFF switch pushing more than 10 seconds.

If operation is not as specified, replace the actuator.

- Release the switch, then release the brake pedal.

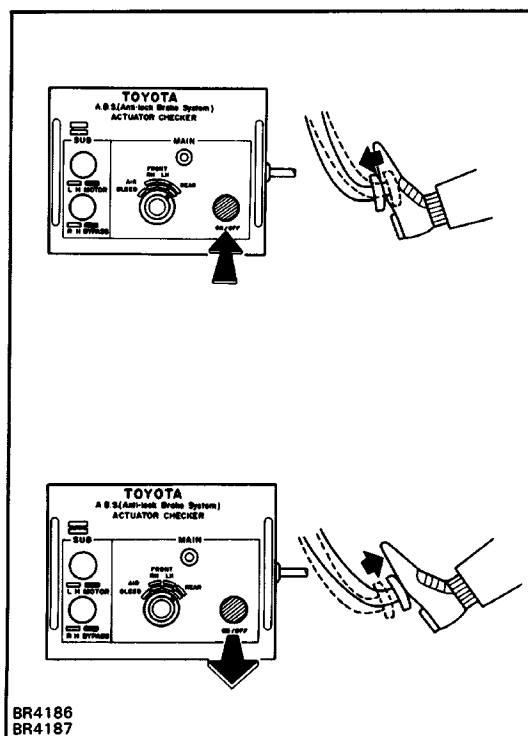

**5. REMOVE ACTUATOR CHECKER (SST)**

Remove SST, then connect the connectors of the actuator and solenoid relay.

SST 09990-00150 and 09990-00205

**6. REMOVE SST FROM WHEEL CYLINDER**

**SST 09709-29017**

**7. REMOVE PRESSURE GAUGE FROM PS PUMP**

Remove the pressure gauge from the PS line, then bleed the power steering system.

**8. BLEED SYSTEM**

(a) Fill brake reservoir with brake fluid.

(b) Fill PS reservoir with fluid.

**Fluid type: ATF DEXRON® II**

(c) Bleed the system.

(See page [BR-94](#))

**REMOVAL OF BRAKE ACTUATOR****1. REMOVE BATTERY**

Disconnect the wire harnesses from the terminals and remove the battery and tray.

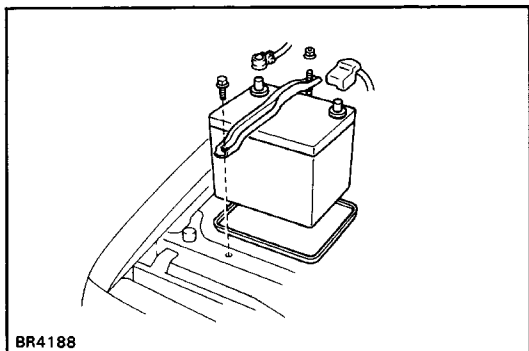

BR4188

**2. DISCONNECT CONNECTOR**

Disconnect the connector from the actuator.

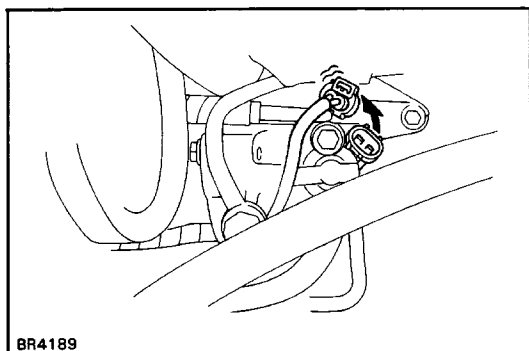

BR4189

**3. DISCONNECT TWO BRAKE TUBES**

Using SST, disconnect the two brake tubes.

SST 09751-36011

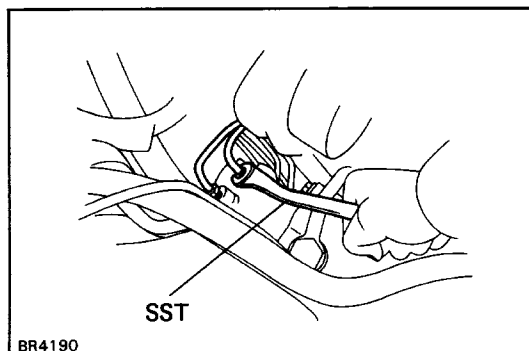

BR4190

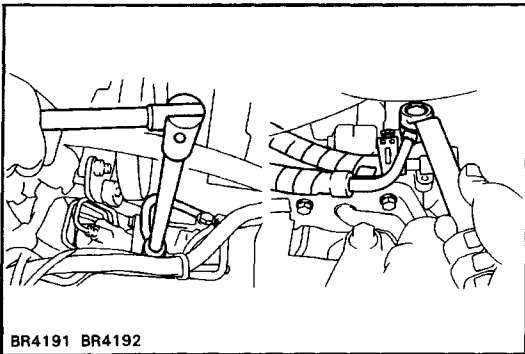

#### 4. DISCONNECT POWER STEERING LINES FROM ACTUATOR

HINT: Turn the steering wheel clockwise until it locks before disconnecting the PS lines. And if you cannot work from the upper side, work from the wheel house.

- (a) Remove the two union bolts and disconnect the two power steering pressure tubes.
- (b) (22R-E Engine)  
Disconnect the power steering line hose.
- (c) (3VZ-E Engine)  
Disconnect the two power steering line hoses.

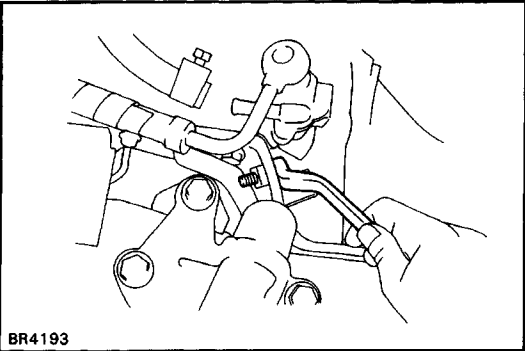

#### 5. REMOVE PS TUBE CLAMP INSTALLATION BOLT

Remove the installation bolt of the power steering tube clamp.

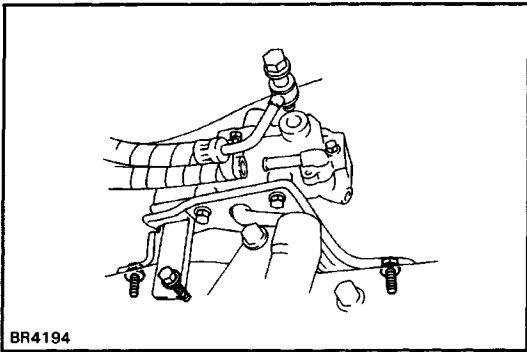

#### 6. REMOVE ACTUATOR

Remove the three bolts and remove the actuator from the wheel house.

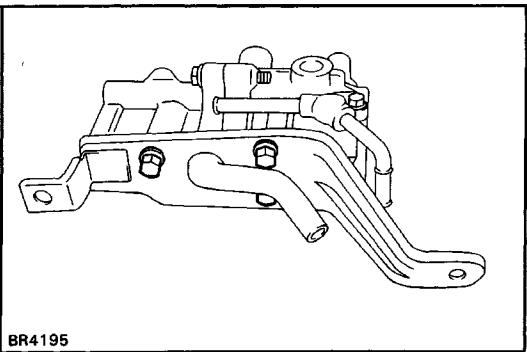

#### 7. REMOVE BRACKET FROM ACTUATOR

Remove the three bolts and separate the actuator and bracket.

## INSTALLATION OF BRAKE ACTUATOR

### 1. INSTALL BRACKET TO ACTUATOR

Install the bracket to the actuator with the three bolts.

**Torque: 13 N-m (130 kgf-cm, 9 ft-lbf)**

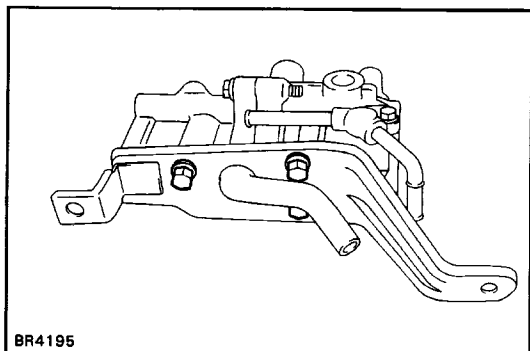

BR4195

### 2. INSTALL ACTUATOR

Install the actuator in place and tighten the three bolts.

**Torque: 28 N-m (290 kgf-cm, 21 ft-lbf)**

HINT: Install the bolts in following order.

- (1) Front side bolt
- (2) Wheel house side bolt of rear bolts
- (3) Upper side bolt on frame of rear bolts

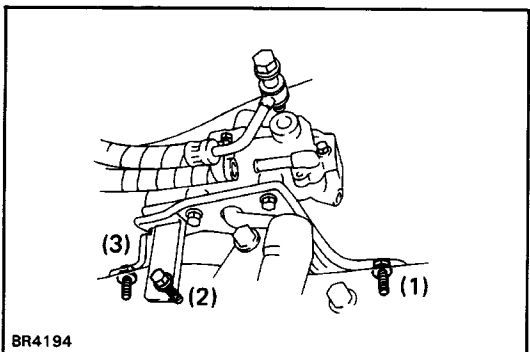

BR4194

### 3. CONNECT POWER STEERING LINES

- (a) Set the pressure union and new gaskets in place, then install the union bolt.

**Torque: 47 N-m (475 kgf-cm, 34 ft-lbf)**

- (b) Similarly connect the other pressure tube.
- (c) Connect the PS line hose to the actuator, then fix it with the hose clamp.
- (d) (3VZ-E Engine)  
Similarly connect the other PS line hose.

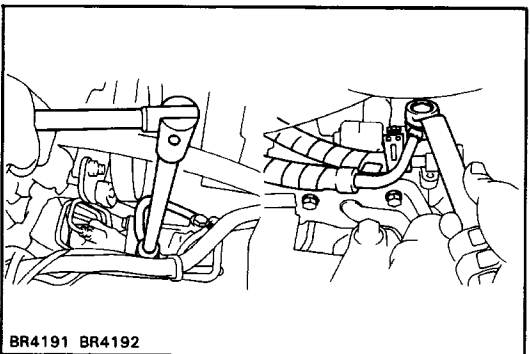

BR4191 BR4192

### 4. INSTALL PS TUBE CLAMP

Install the PS pressure tube clamp in place and tighten the bolt.

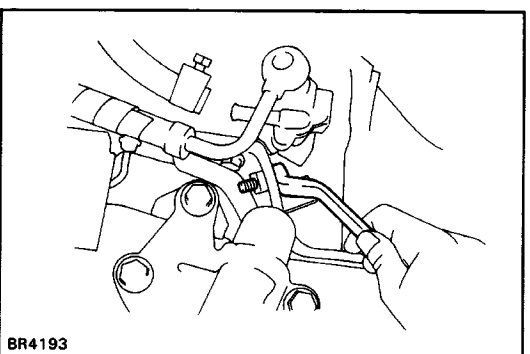

BR4193

### 5. CONNECT TWO BRAKE TUBES

Using SST, connect the two brake tubes to the actuator.  
SST 09751-36011

**Torque: 15 N-m (155 kgf-cm, 11 ft-lbf)**

HINT: First connect the painted brake tube to the painted hole of the actuator, then the other.

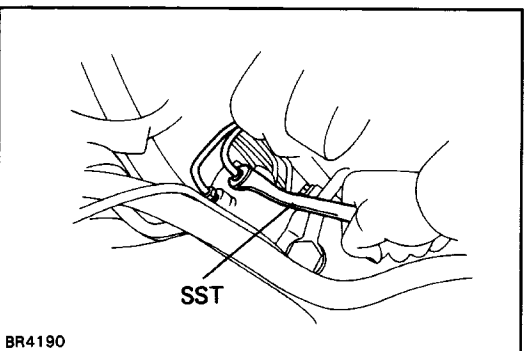

BR4190

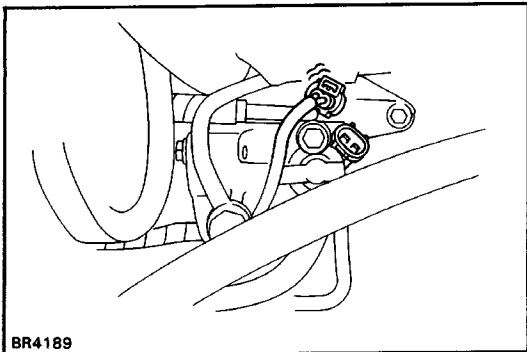

## 6. CONNECT CONNECTOR

Connect the connector to the actuator.

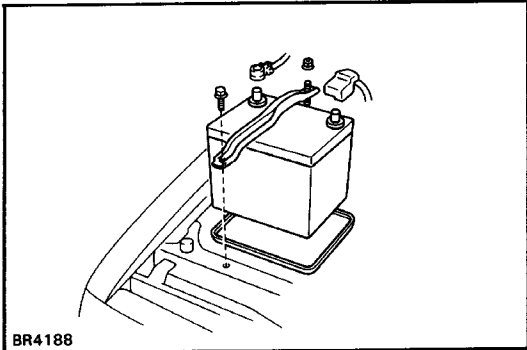

## 7. INSTALL BATTERY

Install the tray and battery in place, then connect the wire harnesses to the terminals.

## 8. BLEED SYSTEM

- (a) Fill brake reservoir with brake fluid.
- (b) Fill PS reservoir with fluid.

**Fluid type: ATF DEXRON<sup>®</sup>II**

- (c) Bleed the system.

(See page [BR-94](#))

## BLEEDING OF REAR-WHEEL ANTI-LOCK BRAKE SYSTEM

HINT: Whenever PS hoses or PS pressure tube are disconnected or actuator is removed from the vehicle, the Rear-Wheel Anti-Lock Brake System should be bled in the following procedure.

At the other times, use the conventional procedure.

### 1. BLEED POWER STEERING SYSTEM

Use the conventional procedure.

### 2. BLEED BRAKE SYSTEM

- (a) Bleed the system with the engine running.
- (b) Bleed the system with the engine off.

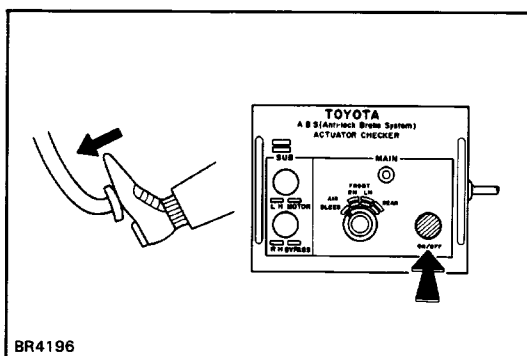
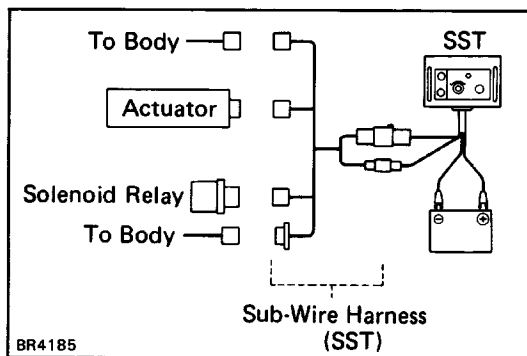

### 3. BLEED POWER STEERING SYSTEM AGAIN

- (a) Disconnect the connector from the actuator.
- (b) Disconnect the connector from the solenoid relay.
- (c) Connect the actuator checker (SST) to the actuator, solenoid relay and body side wire harness through the sub-wire harness (SST) as shown.  
SST 09990-00150 and 09990-00205
- (d) Connect the red cable of the checker to the battery positive (+) terminal and black to the negative (-) terminal.
- (e) Start the engine, and run it at idle.
- (f) Turn the selector switch of actuator checker to "AIR BLEED" position.
- (g) Strongly depress the brake pedal and hold it.
- (h) Push on and release the ON/OFF switch three seconds each for five times.

#### NOTICE:

- To avoid damaging the master cylinder piston cup, do not push on SST switch before depressing the brake pedal and do not release your foot from the brake pedal while SST switch is pushing on.
  - Do not keep the ON/OFF switch pushing more than 10 seconds.
- (i) Release the switch, then release the brake pedal.
  - (j) Check the PS and brake fluid level, and add the fluid if necessary.
  - (k) Remove SST, then connect the connectors of the actuator and solenoid relay.  
SST 09990-00150 and 09990-00205

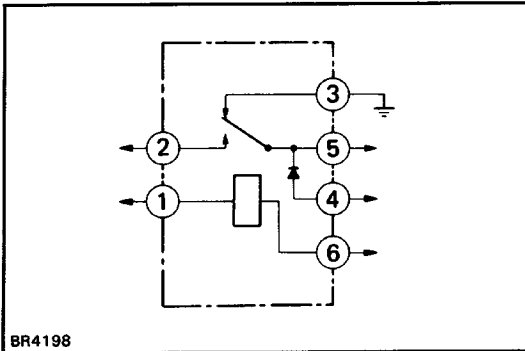
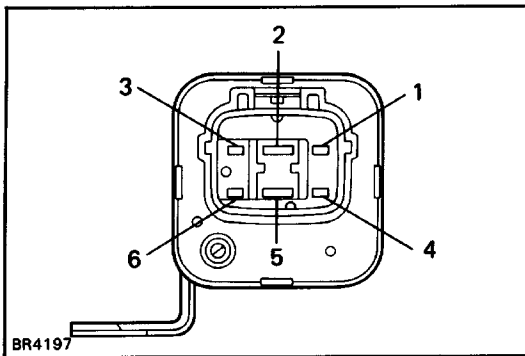

## Control Relay

### INSPECTION OF SOLENOID RELAY

#### INSPECT SOLENOID RELAY OPERATION

Inspect the relay continuity between terminals.

Terminal	6	1	2	3	5	4
Condition						
Constant	○—○			○—○	○—○	○—○
Apply battery positive voltage between terminals 1 and '6			○—○		○—○	○—○

If relay operation is not as specified, replace the solenoid relay.



## Speed Sensor

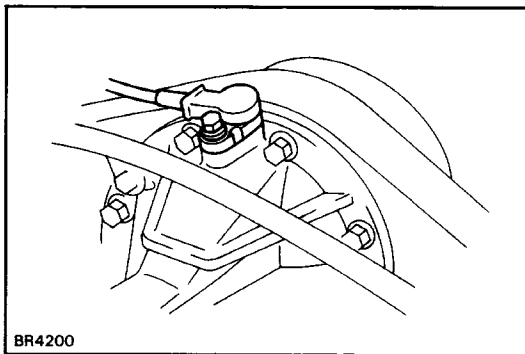
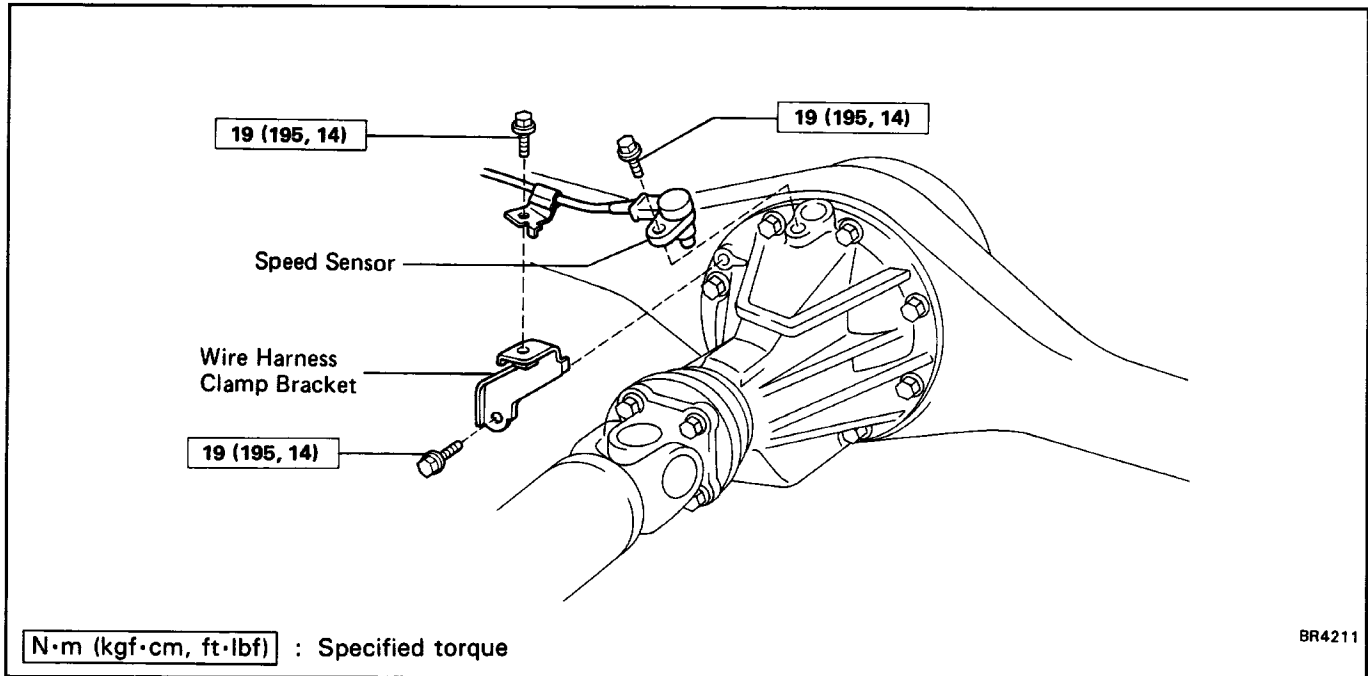

## INSPECTION OF SPEED SENSOR

### 1. INSPECT SENSOR INSTALLATION

Check that the sensor installation bolt is tightened properly.

If not, tighten the bolt.

**Torque: 19 N·m (195 kgf·cm, 14 ft·lbf)**

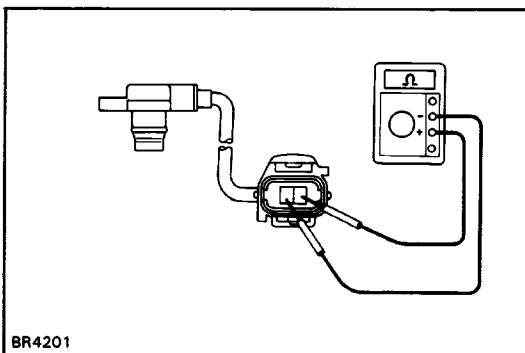

### 2. INSPECT SPEED SENSOR

(a) Disconnect the speed sensor connector.

(b) Measure the resistance between terminals.

**Resistance: 580 - 700**

If resistance value is not as specified, replace the sensor.

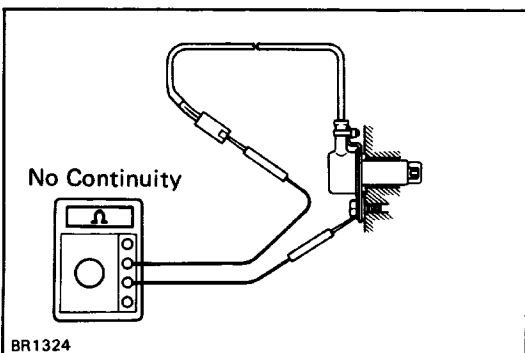

(c) Check that there is no continuity between each terminal and sensor body.

If there is continuity, replace the sensor.

(d) Connect the speed sensor connector.

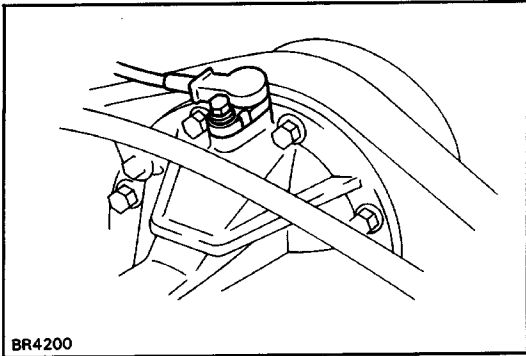

BR4200

### 3. VISUALLY INSPECT SENSOR ROTOR SERRATIONS

- (a) Disconnect the speed sensor wire harness clamp bolt.
- (b) Remove the speed sensor installation bolt and pull out the speed sensor.

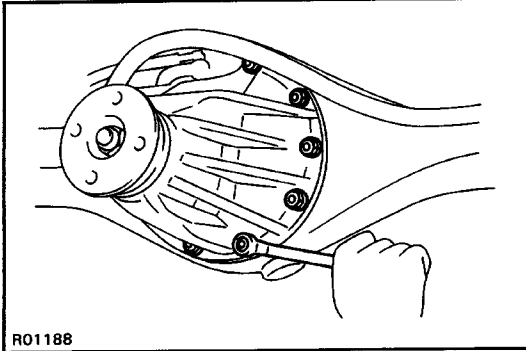

R01188

- (c) Remove the differential carrier assembly.  
(See page [SA-136](#))  
**NOTICE:** To prevent damage to the ring gear serrations, do not strike the ring gear.

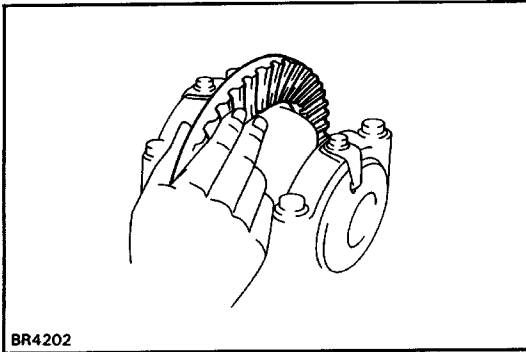

BR4202

- (d) Inspect the ring gear (sensor rotor) serrations for scratches, cracks, warping or missing teeth.  
If necessary, replace the ring gear.

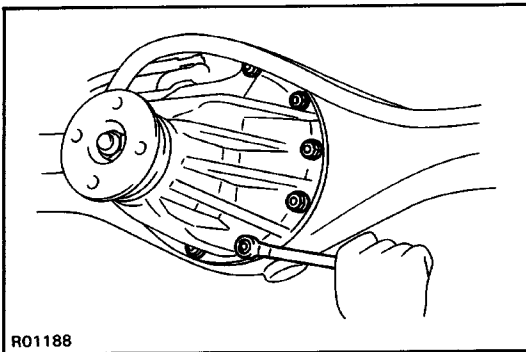

R01188

- (e) Install the differential carrier assembly.  
(See page [SA-151](#) )

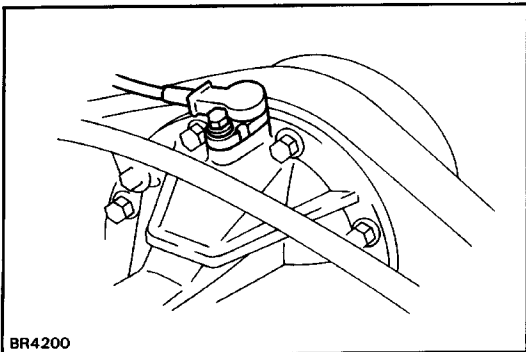

BR4200

- (f) Install the speed sensor and tighten the installation bolt.  
**Torque: 19 N-m (195 kgf-cm, 14 ft-lbf)**
- (g) Set the speed sensor wire harness clamp in place and tighten the clamp bolt.  
**Torque: 19 N-m (195 kgf-cm, 14 ft-lbf)**

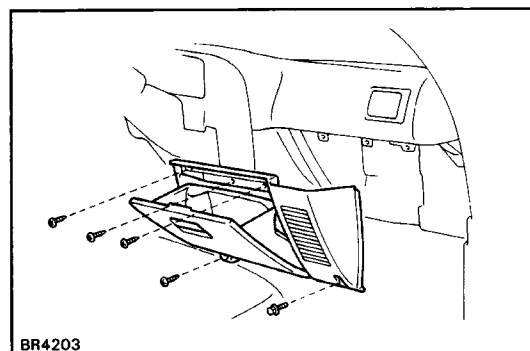
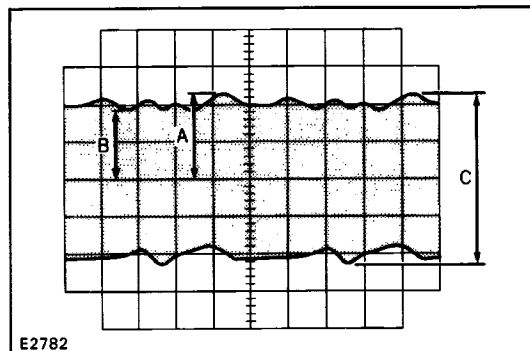
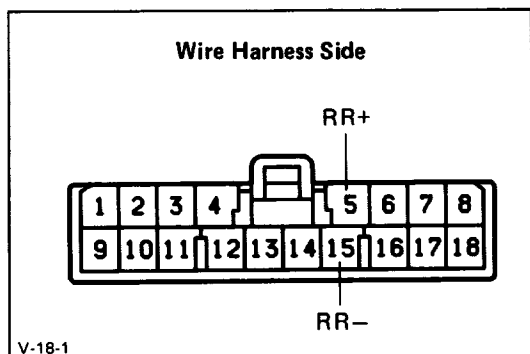
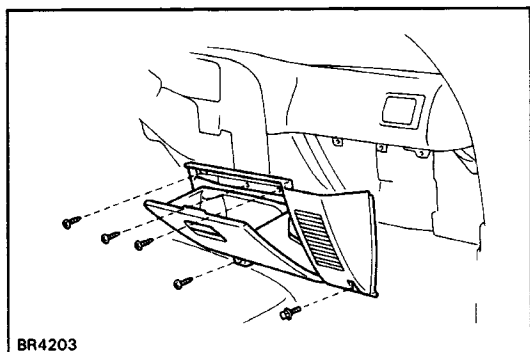

## INSPECTION OF SPEED SENSOR AND SENSOR ROTOR SERRATIONS (REFERENCE)

### INSPECT SPEED SENSOR AND SENSOR ROTOR SERRATIONS BY USING AN OSCILLOSCOPE

- (a) Remove the glove box assembly and disconnect the radio speaker connector.
- (b) Disconnect the connector from the rear-wheel anti-lock brake system ECU.
- (c) Connect an oscilloscope to the terminals RR + and RR - on the wire harness side connector.
- (d) Run the vehicle at 20 km/h (0 2.4 mph), and inspect speed sensor output wave.
- (e) Check that C is 0.4 V or more.  
If it is not as specified, replace the speed sensor.
- (f) Check that B is 70% or more of A.  
If it is not as specified, replace the sensor rotor.
- (g) Remove the oscilloscope and connect the connector to the ECU.
- (h) Connect the radio speaker connector and install the glove box assembly.

## Deceleration Sensor

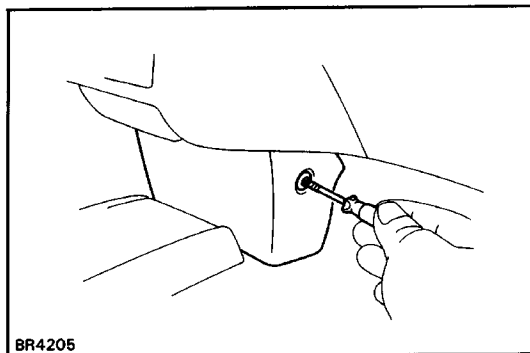
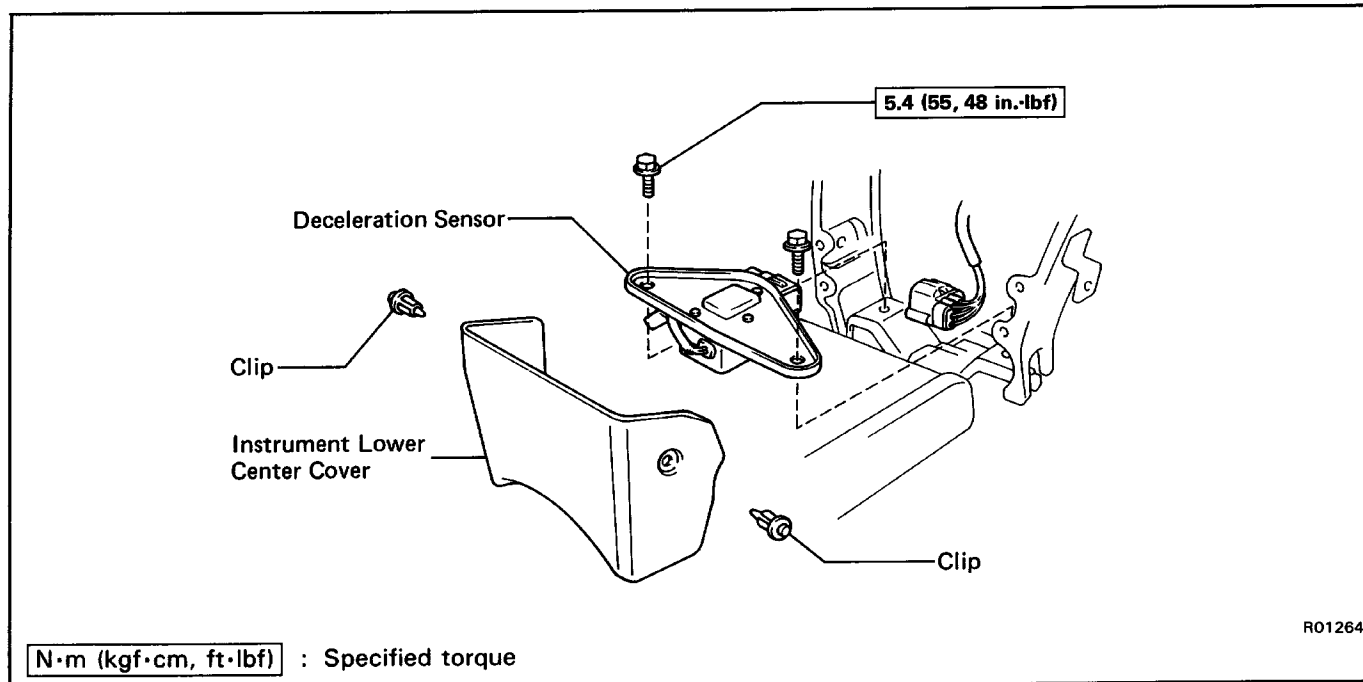

## INSPECTION OF DECELERATION SENSOR

### INSPECT SENSOR INSTALLATION

(a) Remove the two clips, then remove the instrument lower center cover.

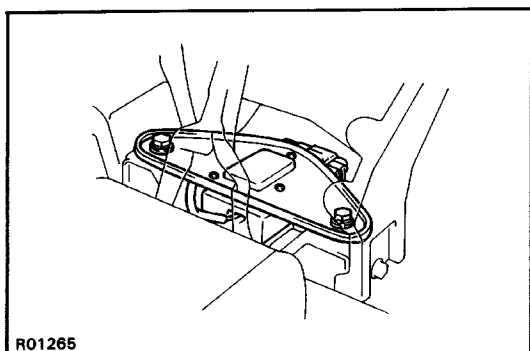

(b) Inspect that the sensor direction is correct.

(c) Check that the sensor installation bolts are tightened properly.

If not, tighten the bolts.

**Torque: 5.4 N·m (55 kgf·cm, 48 in.-lbf)**

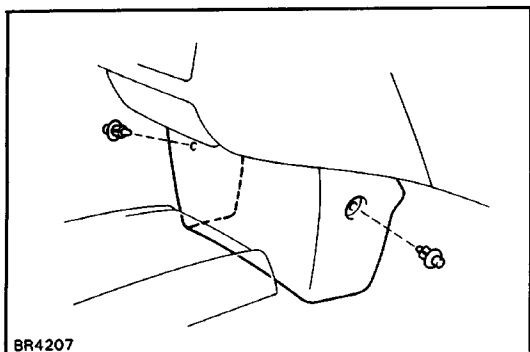

(d) Install the instrument lower center cover and two clips.

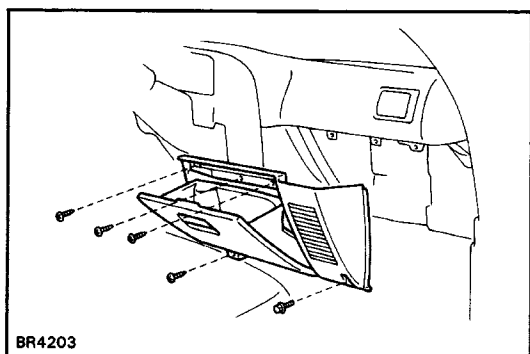

BR4203

## Rear-Wheel Anti-Lock Brake System Circuit

### REMOVAL OF REAR-WHEEL ANTI-LOCK BRAKE SYSTEM ECU

#### 1. REMOVE GLOVE BOX ASSEMBLY

Remove the four screws and a bolt, then remove the glove box assembly and disconnect the radio speaker connector.

#### 2. REMOVE ECU

- (a) Remove the two screws and a nut.
- (b) Pull out the ECU.

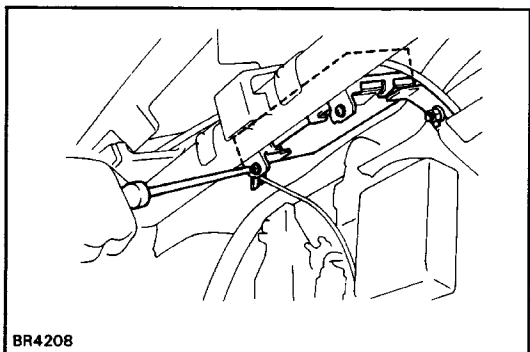

BR4208

## INSPECTION OF SYSTEM CIRCUIT

### 1. INSPECT SYSTEM CIRCUIT WITH CONNECTOR CONNECTED

Using a voltmeter with high impedance (10 k/ N minimum), measure the voltage at each terminal and body ground.

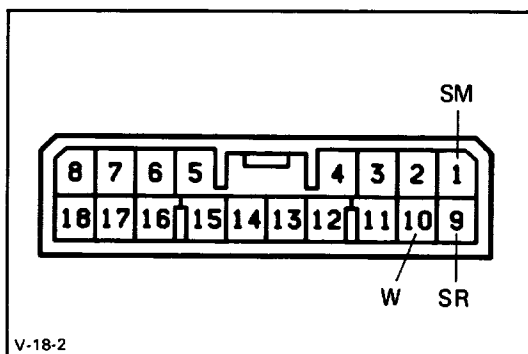

V-18-2

Tester Connection	Condition	Voltage	Trouble Part
SM - Body ground	Ignition switch ON	Battery positive voltage	Solenoid relay, Actuator
	Ignition switch ON and "REAR ANTILOCK" warning light goes on	About 0 V	
SR - Body ground	Ignition switch ON	Battery positive voltage	
	Ignition switch ON and "REAR ANTILOCK" warning light goes on	About 0 V	
W - Body ground	Ignition switch ON	Battery positive voltage	Warning light bulb
	Ignition switch ON and "REAR ANTILOCK" warning light goes on	About 0 V	

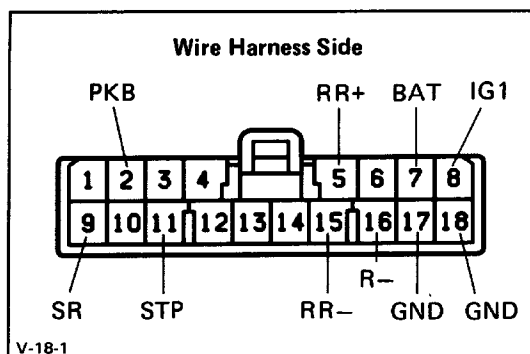

## 2. INSPECT SYSTEM CIRCUIT WITH CONNECTOR DISCONNECTED

- (a) Disconnect the connector from the ECU and inspect at the wire harness side connector.

Tester Connection	Check Item	Condition	Voltage or Resistance Value	Trouble Part
PKB - Body ground	Voltage	Ignition SW on and PKB lever pulled	About 0 V	PKB switch, level warning switch
		Ignition SW on and PKB lever returned	Battery positive voltage	
RR+ - RR-	Resistance	-	580 - 700 Ω	Speed sensor
BAT - Body ground	Voltage	-	Battery positive voltage	Wire harness
IG1 - Body ground	Voltage	Ignition SW on	Battery positive voltage	ECU-IG fuse, wire harness
		Ignition SW off	About 0 V	
SR - R-	Resistance	-	80 Ω	Solenoid relay
STP - Body ground	Voltage	Ignition SW off and brake pedal depressed	Battery positive voltage	Stop light switch, stop light
	Continuity	Ignition SW off and brake pedal returned	Continuity	
GND - Body ground	Continuity	-	Continuity	Wire harness

If the circuit is not as specified, check and repair or replace the trouble part shown in the table above.

- (b) Connect the connector.

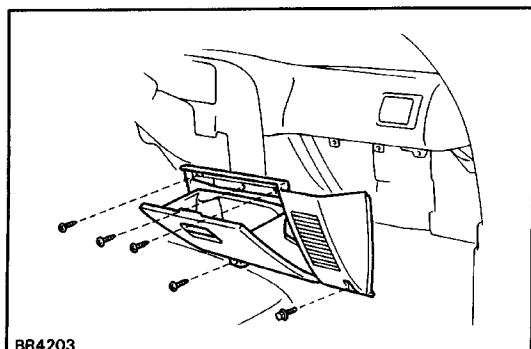

## INSTALLATION OF ECU

### 1. INSTALL ECU

Install the ECU in place with a nut and two screws.

### 2. INSTALL GLOVE BOX ASSEMBLY

Connect the radio speaker connector and install the glove box assembly in place and install the four screws and a bolt.

# STEERING

## PRECAUTION

Care must be taken to replace parts properly because they may affect the performance of the steering system and result in a driving hazard.

## TROUBLESHOOTING

Problem	Possible cause	Remedy	Page
Hard steering	Tires improperly inflated Insufficient lubricant Excessive caster Steering system joints worn Lower arm ball joints worn Steering column binding Steering gear out of adjustment or broken  Power steering belt loose Fluid level in reservoir low Power steering unit faulty  Solenoid valve faulty Electronic control faulty	Inflate tires to proper pressure Lubricate suspension Check front wheel alignment Replace steering system joints Replace lower arm ball joints Inspect steering column Adjust or repair steering gear Adjust belt Check reservoir Check power steering unit  Inspect solenoid valve Inspect electronic control	<a href="#">SA-3</a> , 6  <a href="#">SA-3</a> , 6 <a href="#">SR-93</a> , 97 <a href="#">SA-17</a> , 112 <a href="#">SR-4</a> <a href="#">SR-19</a> , 26 65,75 <a href="#">SR-40</a> <a href="#">SR-40</a> <a href="#">SR-45</a> , 65 75 <a href="#">SR-91</a> <a href="#">SR-87</a>
Poor return	Tires improperly inflated Insufficient lubricant Wheel alignment incorrect Steering column binding Steering gear out of adjustment or broken	Inflate tires to proper pressure Lubricate suspension Check front wheel alignment Inspect steering column Adjust or repair steering gear	<a href="#">SA-3</a> , 6  <a href="#">SA-3</a> , 6 <a href="#">SR-4</a> <a href="#">SR-19</a> , 26 65, 75
Excessive play	Front wheel bearing worn Main shaft yoke or intermediate shaft yoke worn Lower arm ball joints worn Steering system joints worn Steering gear out of adjustment or broken	Replace front wheel bearing Replace main shaft or intermediate shaft Replace lower arm ball joints Replace steering system joints Adjust or repair steering gear	<a href="#">SA-11</a> , 36 <a href="#">SR-4</a>  <a href="#">SA-17</a> , 112 <a href="#">SR-93</a> , 97 <a href="#">SR-19</a> , 26 65, 75
Abnormal noise	Steering linkage loose Steering system joints worn Steering gear out of adjustment or broken	Tighten steering linkage Replace steering system joints Adjust or repair steering gear	<a href="#">SR-93</a> , 97 <a href="#">SR-93</a> , 97 <a href="#">SR-19</a> , 26 65, 75



## ON-VEHICLE INSPECTION

### STEERING WHEEL FREEPLAY

#### 1. CHECK THAT STEERING WHEEL FREEPLAY IS CORRECT

With the vehicle stopped and pointed straight ahead, rock the steering wheel gently back and forth with light finger pressure. Freeplay should not exceed the maximum limit.

**Maximum play: 30 mm (1.18 in.)**

If incorrect, adjust or repair as required.

#### 2. POINT WHEELS STRAIGHT AHEAD

#### 3. ADJUST STEERING GEAR HOUSING

(a) Loosen the lock nut.

(b) Turn the adjusting screw clockwise to decrease

wheel freeplay and counterclockwise to increase it.

**HINT:** Turn the adjusting screw in small increments and check the wheel freeplay between each adjustment.

#### 4. CHECK THAT STEERING DOES NOT BIND

Turn the steering wheel half way around in both directions.

Check that the freeplay is correct and steering is smooth and without rough spots.

#### 5. HOLD ADJUSTING SCREW AND TIGHTEN LOCK NUT

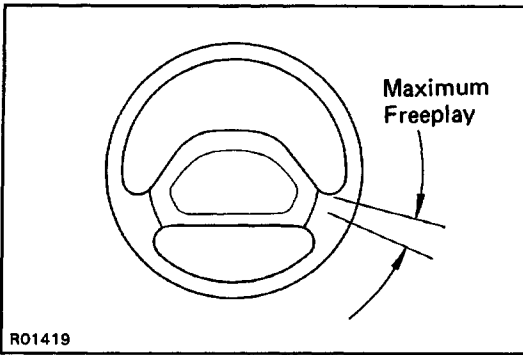

R01419

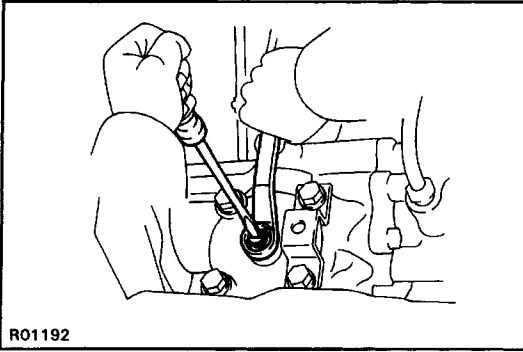

R01192

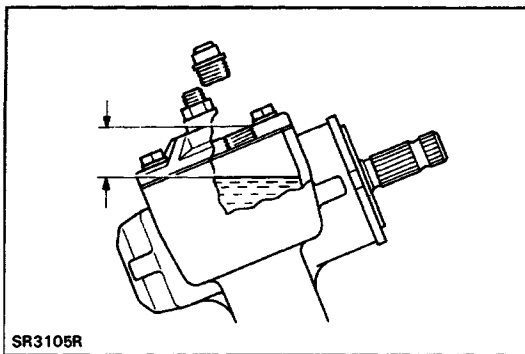

SR3105R

## OIL LEVEL

### CHECK STEERING GEAR HOUSING OIL LEVEL

Oil level:

2WD 18 – 28 mm (0.71 – 1.10 in.)

4WD 14 – 17 mm (0.55 – 0.67 in.)

If low, fill with gear oil and check for leaks.

# STEERING COLUMN REMOVAL AND INSTALLATION OF STEERING COLUMN

Remove and install the parts as shown.

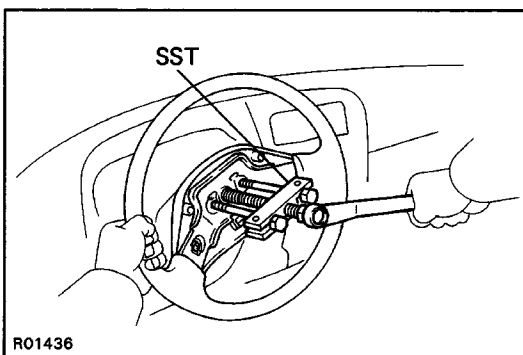
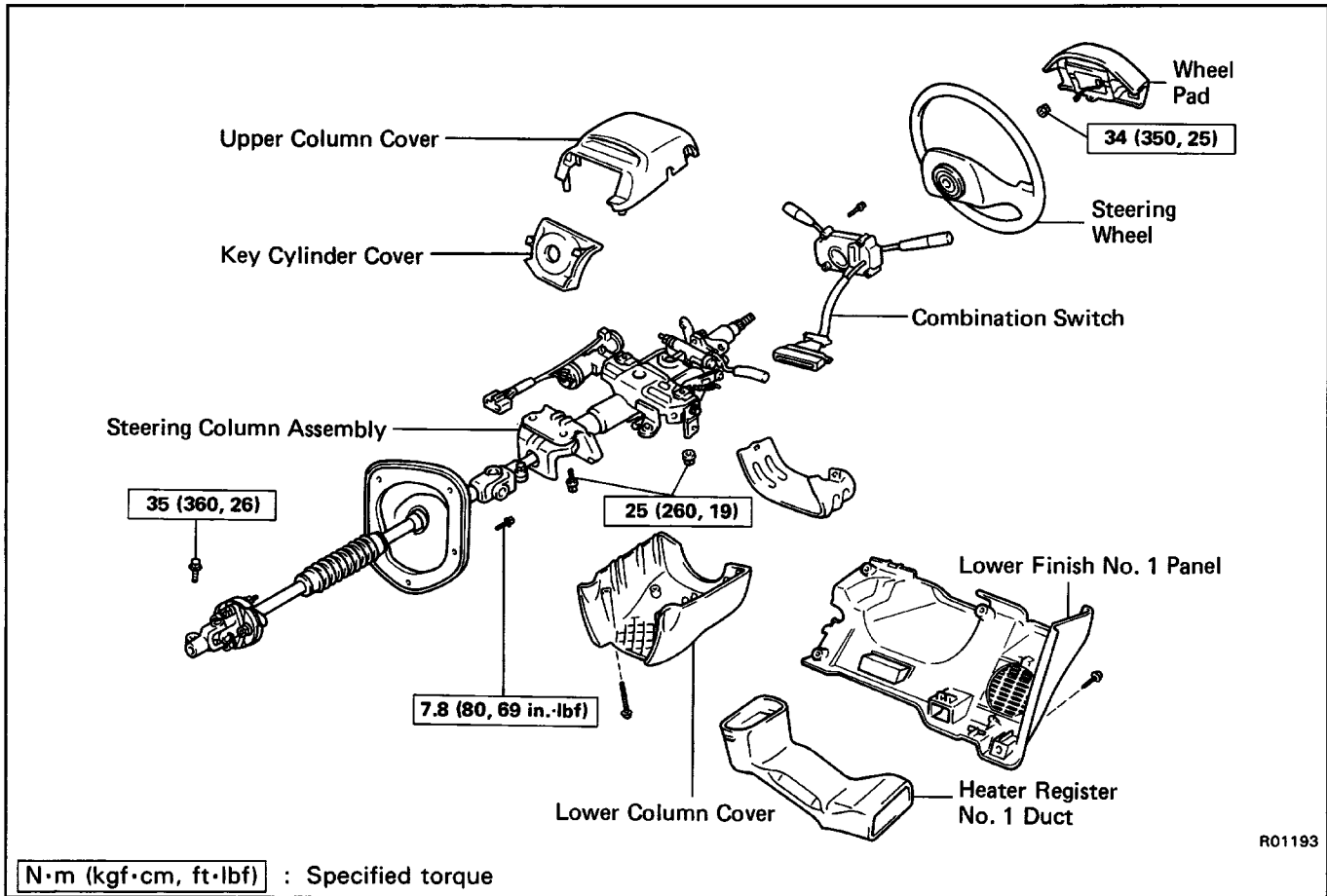

## (MAIN POINTS OF REMOVAL)

### 1. REMOVE STEERING WHEEL

Using SST, remove the steering wheel.  
SST 09609-20011

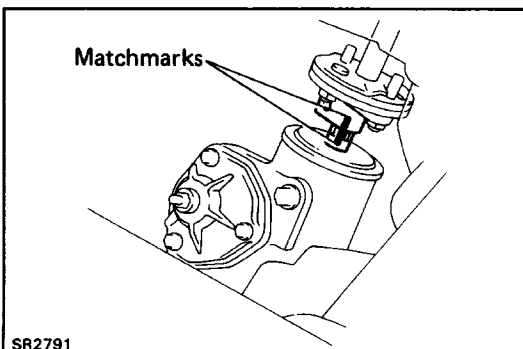

### 2. DISCONNECT MAIN SHAFT

- Place matchmarks on the worm shaft and main shaft.
- Disconnect the main shaft from the worm shaft.

# Non-Tilt Steering Column COMPONENTS

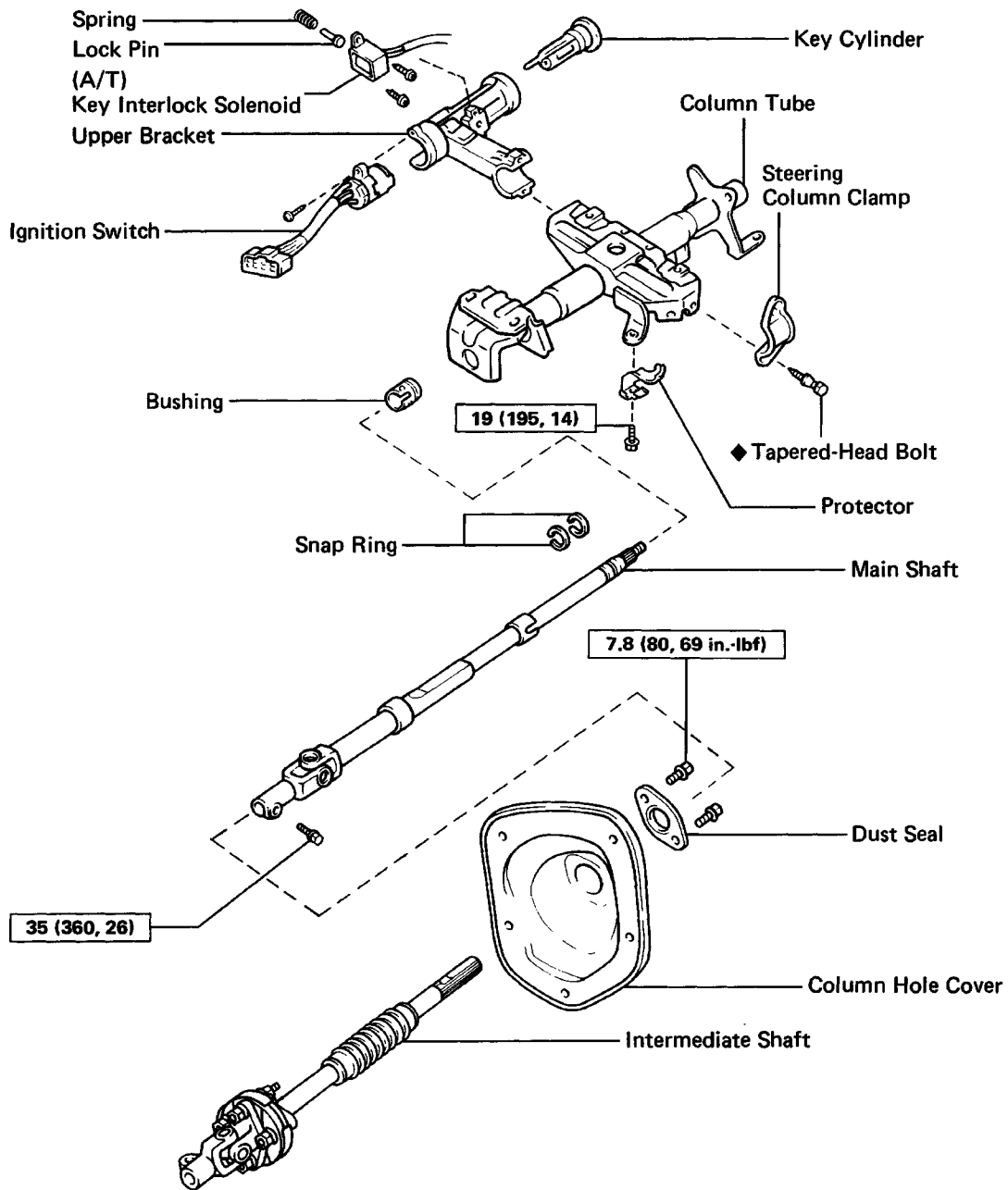

**N·m (kgf·cm, ft·lbf) : Specified torque**

◆ Non-reusable part

## DISASSEMBLY OF STEERING COLUMN

### 1. REMOVE COLUMN HOLE COVER

- (a) Disconnect the intermediate shaft from the main shaft.
- (b) Remove two bolts and the dust seal.
- (c) Remove the column hole cover.

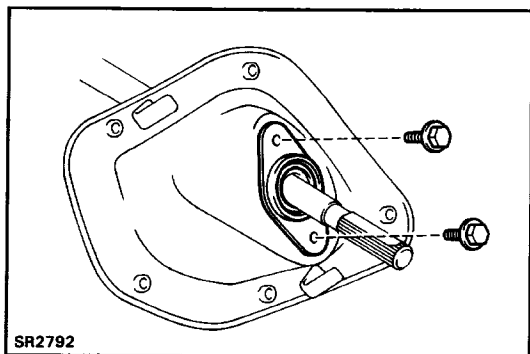

### 2. PULL OUT MAIN SHAFT

- (a) Using snap ring pliers, remove the snap ring.
- (b) Pull out the main shaft from the upper tube.
 

HINT: Do not place the ignition key at the LOCK position.

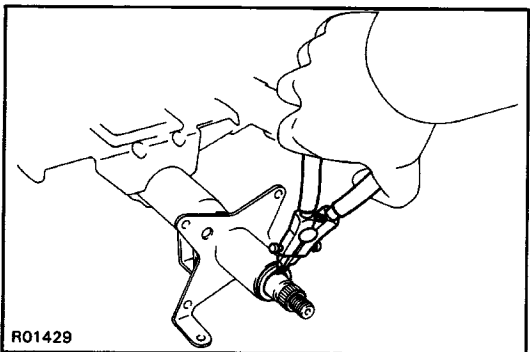

- (c) Using snap ring pliers, remove the snap ring.

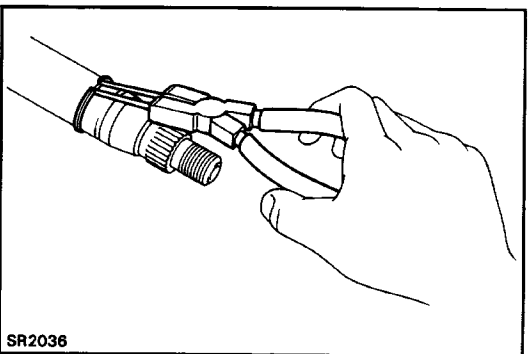

### 3. REMOVE UPPER BRACKET

- (a) Using a centering punch, mark the center of the tapered-head bolts.
- (b) Using a 3 - 4 mm (0.12 - 0.16 in.) drill, drill into the tapered-head bolts.

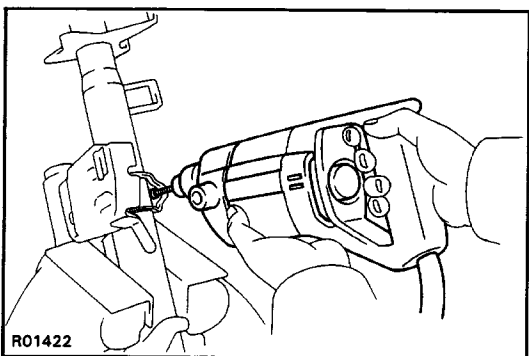

- (c) Using a screw extractor, remove the tapered-head bolts.
- (d) Remove the two bolts and separate the upper bracket and column tube.

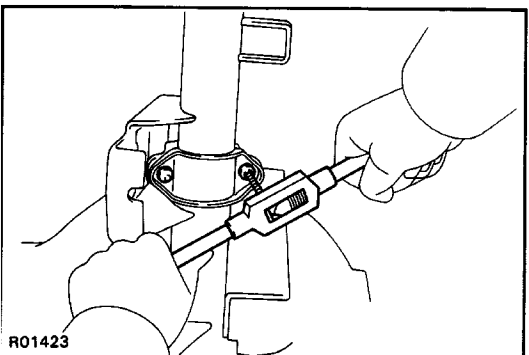

## INSPECTION AND REPLACEMENT OF NON-TILT STEERING COLUMN

### 1. INSPECT UPPER BRACKET

Check that the steering lock mechanism operates properly.

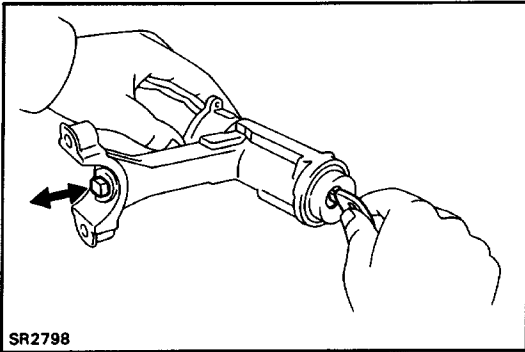

### 2. IF NECESSARY, REPLACE IGNITION KEY CYLINDER

- Place the ignition key at the ACC position.
- Push down the stop key with a thin rod, and pull out the key cylinder.
- Turn the ignition key plate to the ACC position, and install a new key cylinder into the upper bracket.

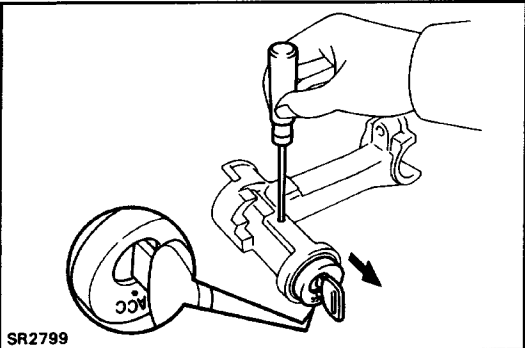

### 3. INSPECT UPPER BEARING

Check the upper bearing rotation condition and check for abnormal noise.

If the bearing is worn or damaged, replace the column tube assembly.

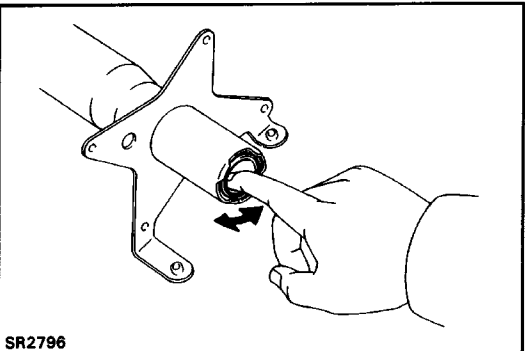

### 4. IF NECESSARY, REPLACE BUSHING

- Using a screwdriver, remove the bushing.

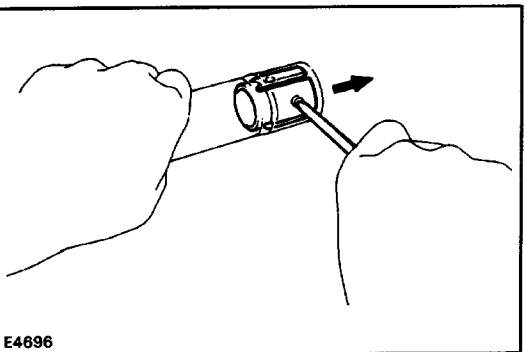

- Align the holes of the tube and the projections of a new bushing, and insert the bushing to the column tube.

### 5. INSPECT KEY INTERLOCK SOLENOID

(See page [AT-213](#))

### 6. IF NECESSARY, REPLACE KEY INTERLOCK SOLENOID

(See page [SR-13](#))

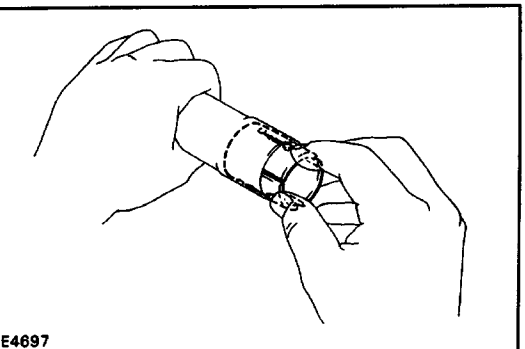

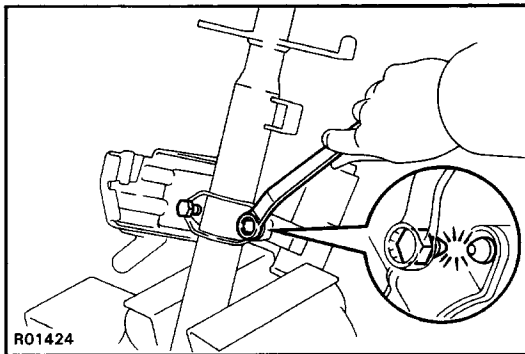

## ASSEMBLY OF NON-TILT STEERING COLUMN

(See page [SR-5](#))

### 1. INSTALL UPPER BRACKET TO COLUMN TUBE

- (a) Install the upper bracket with two new tapered-head bolts.
- (b) Tighten the tapered-head bolts until the bolt heads break off.

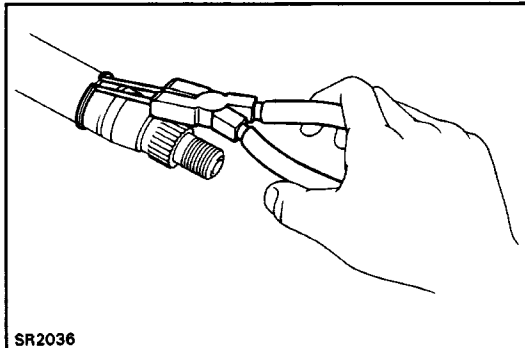

### 2. INSTALL MAIN SHAFT TO COLUMN TUBE

- (a) Using snap ring pliers, install the snap ring in the lower groove of the main shaft.
- (b) Install the main shaft in the column tube.  
HINT: Do not place the ignition key at LOCK position.

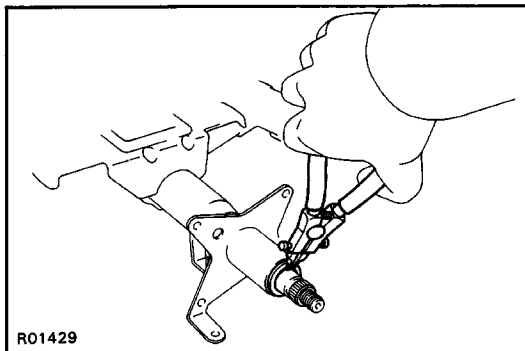

- (c) Using snap ring pliers, install the upper snap ring.

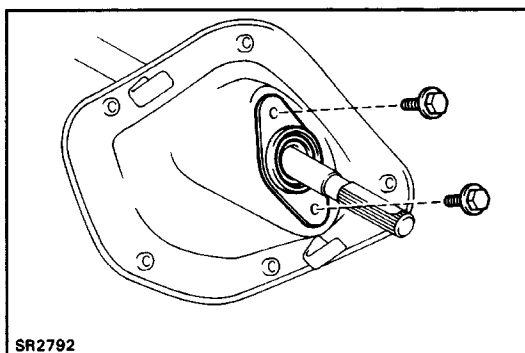

### 3. INSTALL COLUMN HOLE COVER

- (a) Install the intermediate shaft to the column hole cover.
- (b) Temporarily install the two bolts and dust seal.

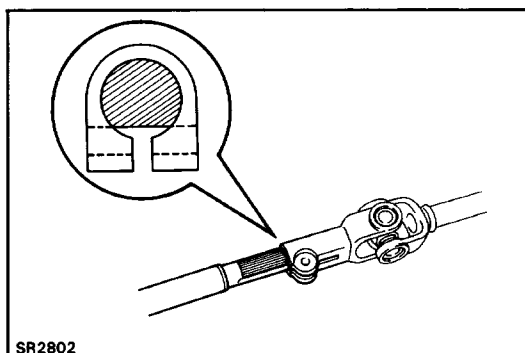

### 4. CONNECT INTERMEDIATE SHAFT WITH MAIN SHAFT

- (a) Place the intermediate shaft in the universal joint as shown.
- (b) Temporarily install the bolt.  
HINT: After install the column to the body, tighten the universal joint set bolt and dust seal bolts.

# Tilt Steering Column COMPONENTS

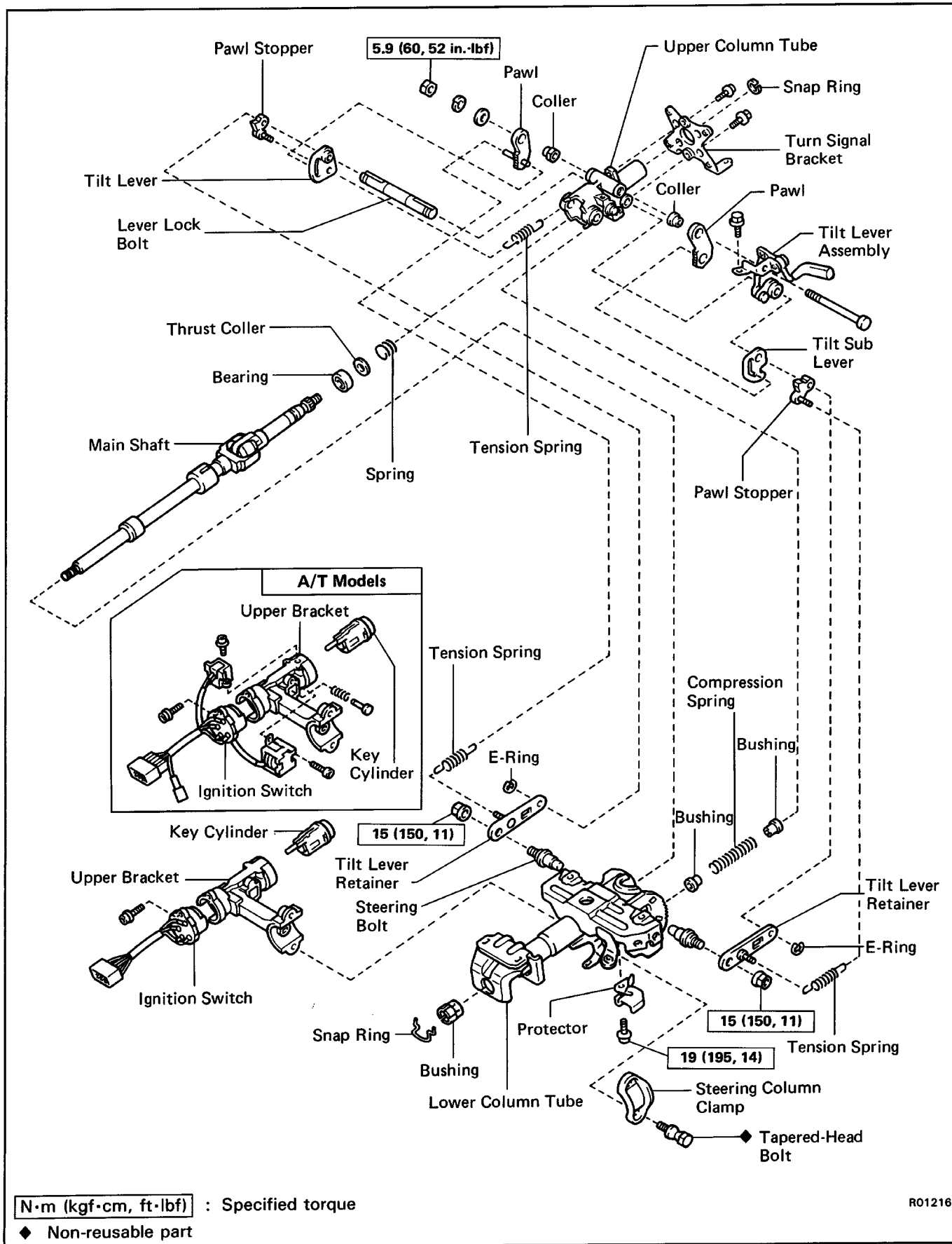

**N·m (kgf·cm, ft·lbf)** : Specified torque

◆ Non-reusable part

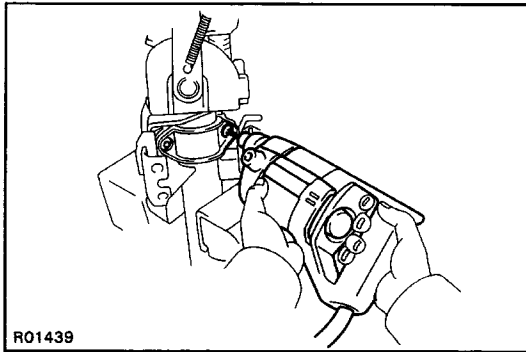

R01439

## DISASSEMBLY OF STEERING COLUMN

(See page [SR-9](#))

### 1. REMOVE UPPER BRACKET

- (a) Using a centering punch, mark the center of the tapered-head bolt.
- (b) Using a 3 – 4 mm (0.12 – 0.16 in.) drill, drill into the tapered-head bolt.

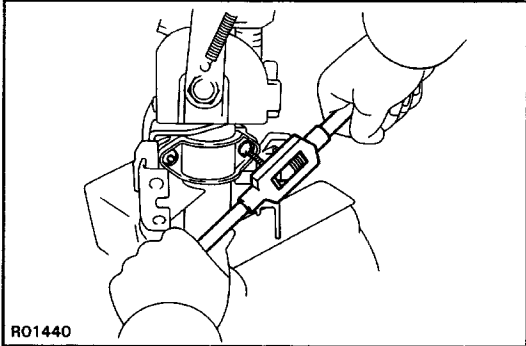

R01440

- (c) Using a screw extractor, remove the tapered-head bolt.
- (d) Remove the two bolts, and separate the upper bracket and the column tube.

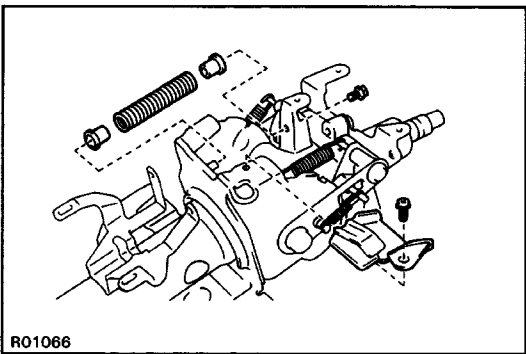

R01066

### 2. REMOVE COMPRESSION SPRING AND TENSION SPRING

- (a) Remove the bolt with the compression spring.
- (b) Remove the bushings from the spring.

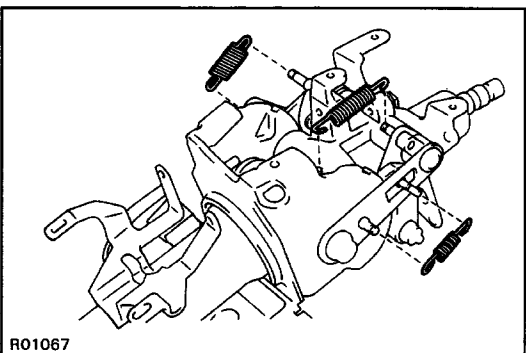

R01067

### 3. REMOVE THREE TENSION SPRINGS

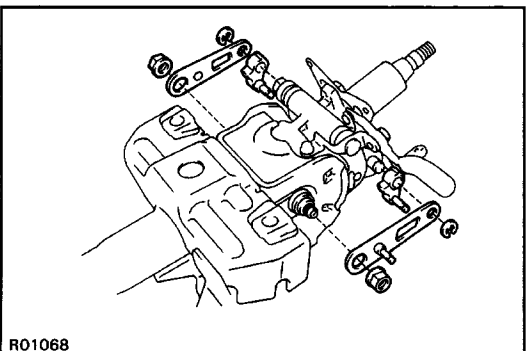

R01068

### 4. REMOVE TWO TILT LEVER RETAINERS

- (a) Remove the E-rings from the retainers.
- (b) Remove the retainers with the nuts.

### 5. REMOVE TWO PAWL STOPPERS

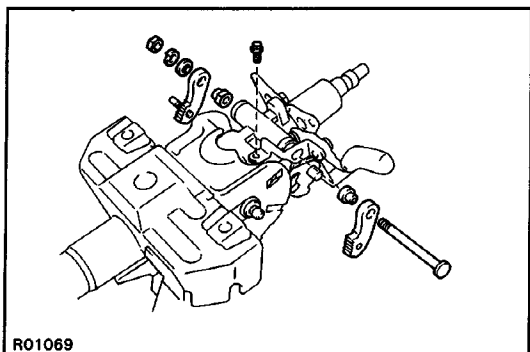

**6. REMOVE TWO TILT PAWLS**

- (a) Remove the nut and bolt.
- (b) Remove the two pawls with the collars.

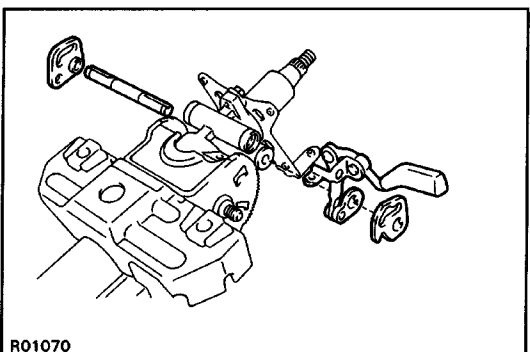
**7. REMOVE TILT LEVER ASSEMBLY, TILT LEVER, TILT SUB LEVER AND LEVER LOCK BOLT**

Remove one screw and tilt lever assembly.

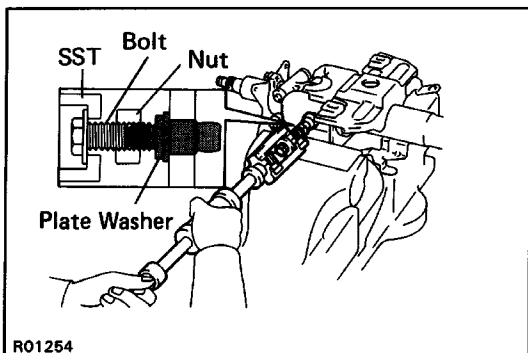
**8. REMOVE UPPER COLUMN TUBE**

- (a) Set SST, the nut (10 mm nominal diameter, 1.25 mm pitch), plate washer (36 mm outer diameter) and bolt (10 mm nominal diameter, 1.25 mm pitch, 50 mm length) as shown. And then remove the two bolts.

SST 09910-00015 (09911-00011, 09912-00010)

(Reference) Nut 90170-10004

Plate washer 90201-10201

Bolt 91111-51050

- (b) Remove the upper column tube from the lower column tube.
- (c) Remove the stopper.

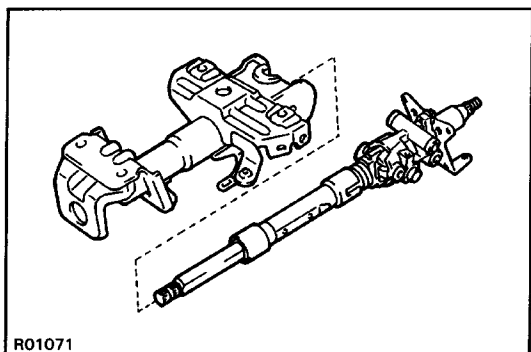
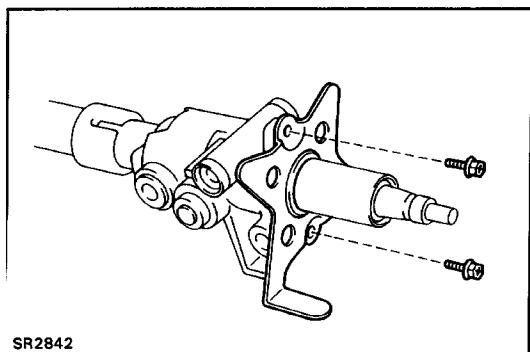
**9. REMOVE TURN SIGNAL BRACKET**

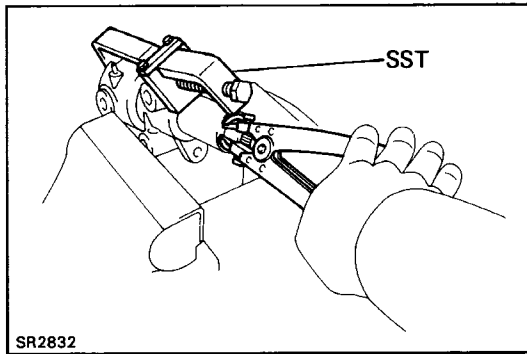

## 10. REMOVE MAIN SHAFT

- (a) Using SST to hold the main shaft, remove the snap ring with snap ring pliers.  
SST 09950-20017

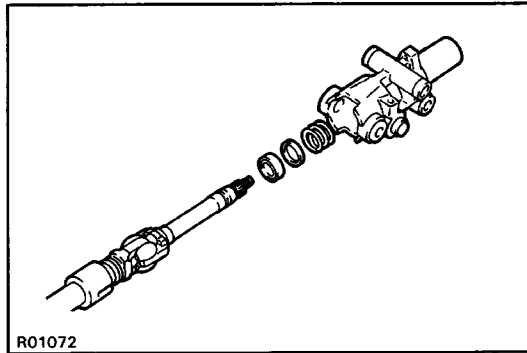

- (b) Remove the main shaft from the column tube.  
(c) Remove the spring, thrust collar and bearing.

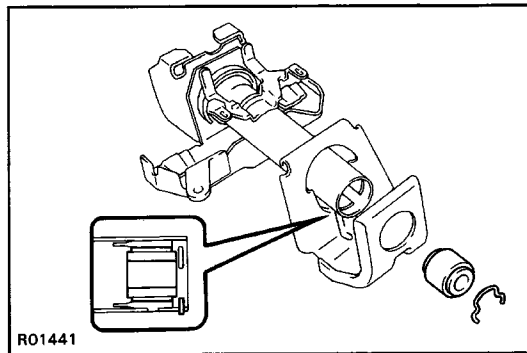

## 11. REMOVE MAIN SHAFT COLLAR

- (a) Remove the snap ring from the lower column tube.  
(b) Remove the main shaft collar.

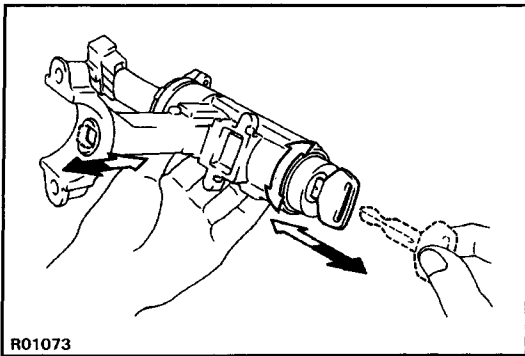

R01073

## INSPECTION AND REPLACEMENT OF STEERING COLUMN

### 1. INSPECT KEY CYLINDER

Check that the steering lock mechanism operates properly.

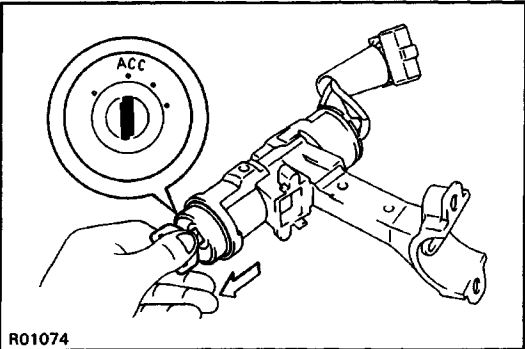

R01074

### 2. IF NECESSARY, REPLACE KEY CYLINDER

- (a) Place the ignition key at the ACC position.
- (b) Push down the stop key with a thin rod, and pull out the key cylinder.
- (c) Make sure that the ignition key is at the ACC position.
- (d) Install a new key cylinder.

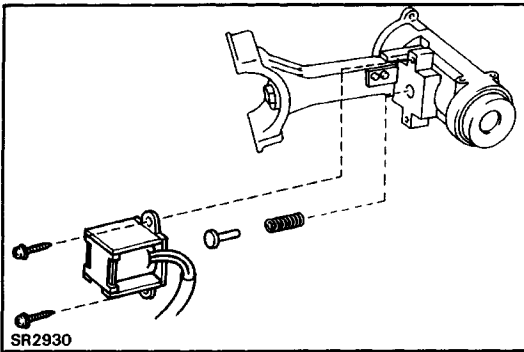

SR2930

### 3. INSPECT KEY INTERLOCK SOLENOID

(See page [AT-214](#))

### 4. IF NECESSARY, REPLACE KEY INTERLOCK SOLENOID

- (a) Remove the two screws.
- (b) Remove the solenoid, spring and lock pin.
- (e) Install a new solenoid with the spring and lock pin, and install the two screws.

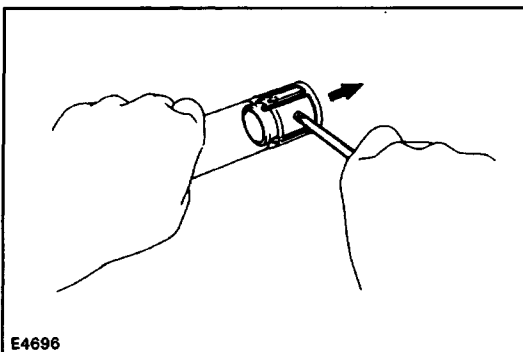

E4696

### 5. IF NECESSARY, REPLACE MAIN SHAFT BUSHING

- (a) Using a screwdriver, remove the bushing.

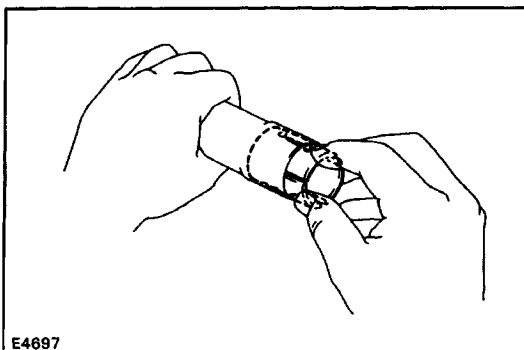

E4697

- (b) Align the holes of the tube and the projections of a new bushing, and install the bushing in the column tube.

**ASSEMBLY OF TILT STEERING COLUMN**(See page [SR-9](#))

1. COAT MOLYBDENUM DISULPHID LITHIUM BASE GREASE ON FOLLOWING PARTS:

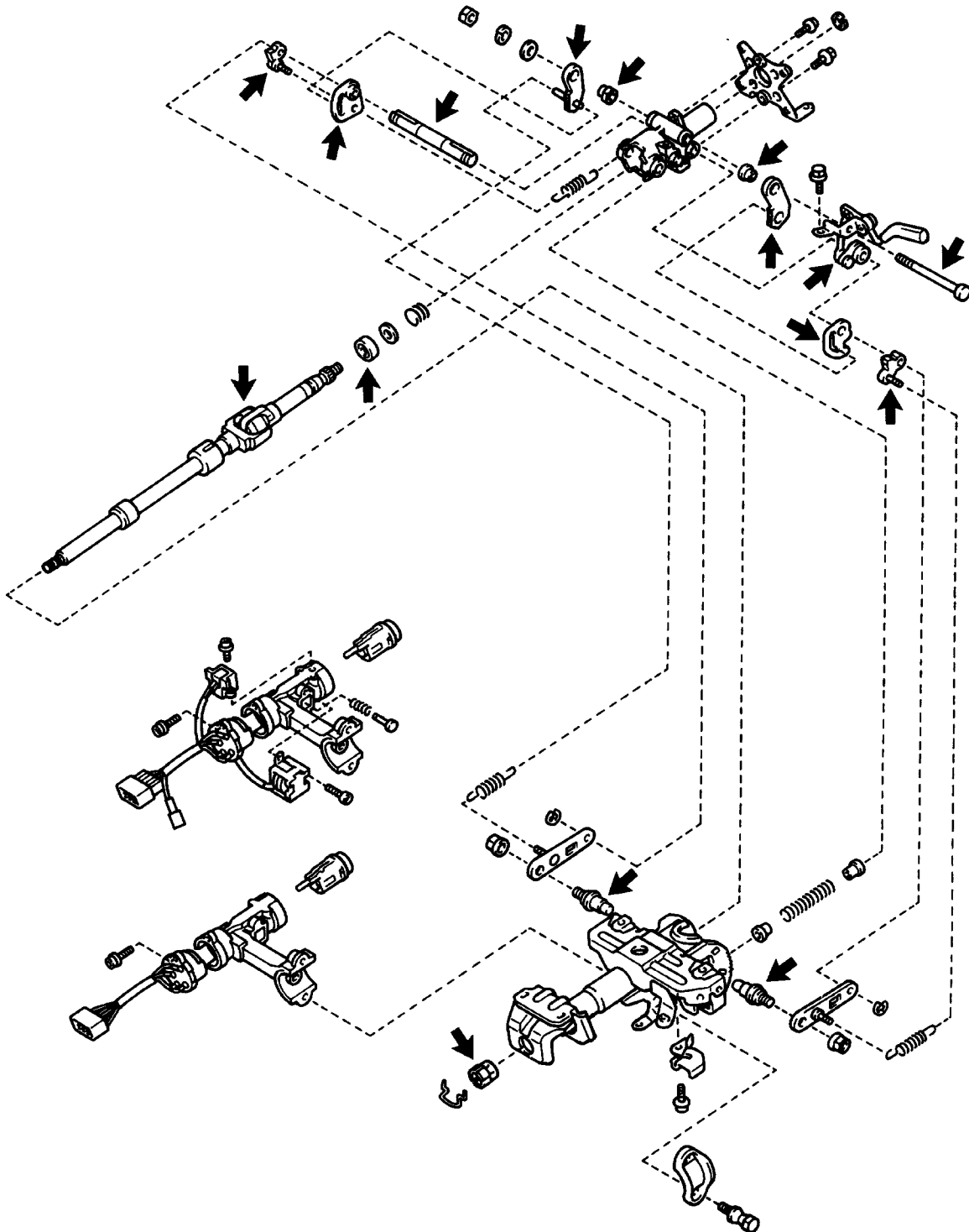

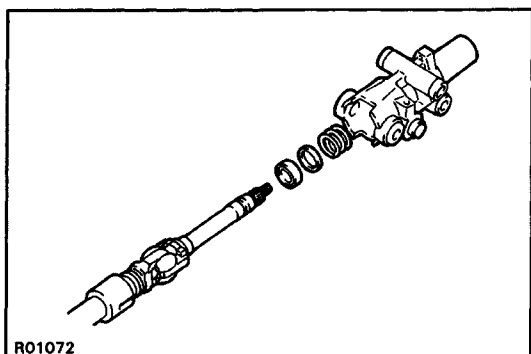

## 2. INSTALL MAIN SHAFT

(a) Install the main shaft with the bearing, collar and spring.

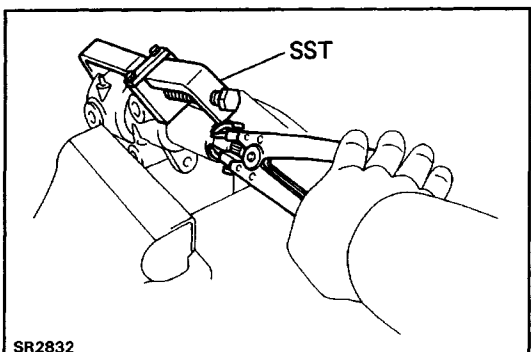

(b) Using SST to hold the main shaft, install the snap ring with snap ring pliers.  
SST 09950-20017

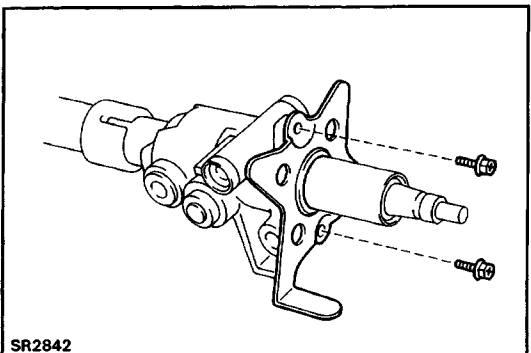

## 3. INSTALL TURN SIGNAL BRACKET

Install the two bolts.

Torque: 7.8 N-m (80 kgf-cm, 69in.-lbf)

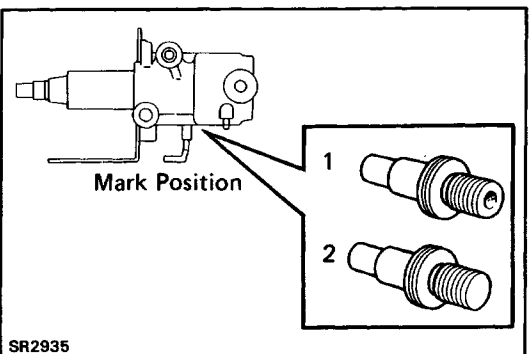

## 4. SELECT STEERING BOLT AND UPPER COLUMN TUBE

Select the bolt with center hole when the upper column tube mark is 1, and select the bolt without hole when the mark is 2.

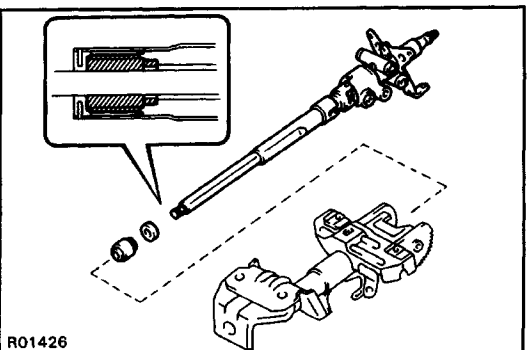

## 5. INSTALL MAIN SHAFT WITH UPPER COLUMN TUBE

(a) Install the stopper and main shaft collar to the main shaft as shown.

(b) Install the main shaft to the lower column tube.

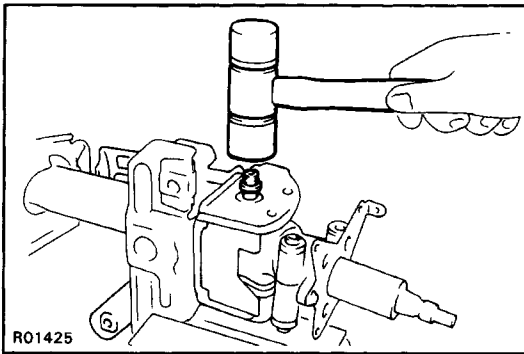

(c) Using a plastic hammer, drive in the steering bolts.

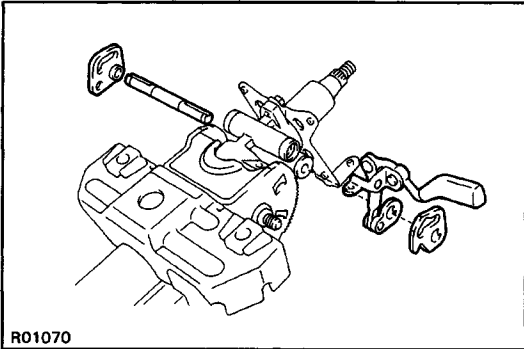

### INSTALL TILT LEVER LOCK BOLT, TILT LEVER ASSEMBLY, TILT LEVER AND TILT SUB LEVER

- (a) Install the tilt lever lock bolt to the upper column tube.
- (b) Install the tilt lever assembly with the screw.
- (c) Install the tilt lever and the tilt sub lever.

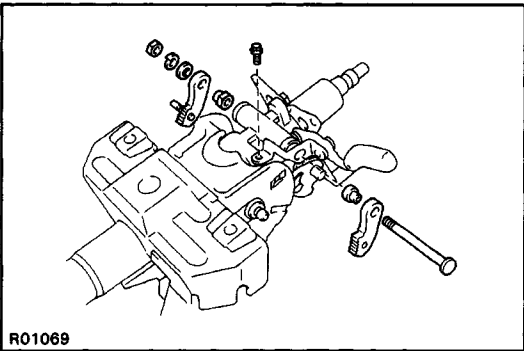

### INSTALL TWO TILT PAWLS

Temporarily install the tilt pawls.

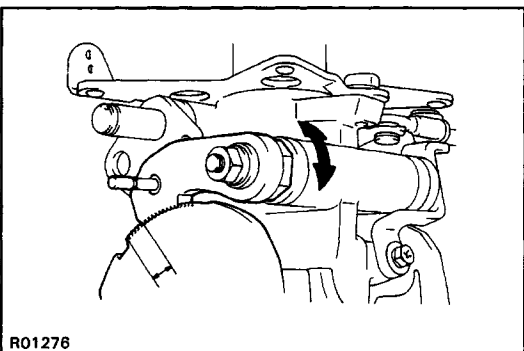

### 8. ENGAGE AND ADJUST TILT PAWL

- (a) Engage the tilt sub lever side pawl to the center of the ratchet.
- (b) While turning the tilt lever side collar, engage the tilt lever side pawl to the ratchet completely.
- (c) Tighten the nut.  
Torque: 5.9 N-m (60 kgf-cm, 52 in.-lbf)

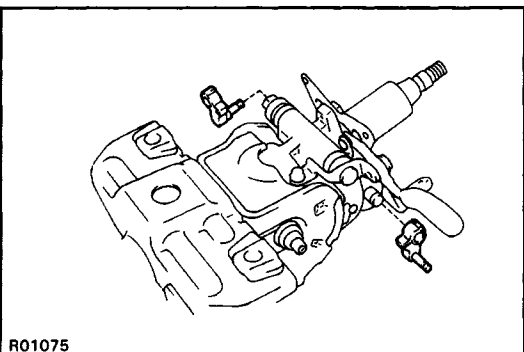

### 9. INSTALL TWO TILT PAWL STOPPERS

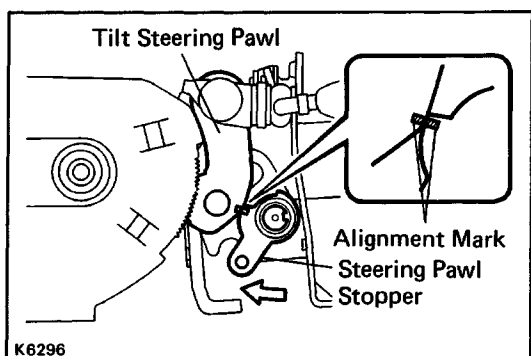

## 10. SELECT STEERING PAWL STOPPERS FOR BOTH SIDES

- With the steering lock pawl and the ratchet engaged, select and install two tilt steering pawl stoppers.
- Check that the alignment marks on the stopper and pawl align when the stopper is rotated to the pawl side.
- If the alignment marks do not align, select tilt steering pawl stoppers according to the following table.

Tilt lever side	Tilt sub lever side	Dimension "A" mm (in.)
1	A	12.65 – 12.75 (0.4980 – 0.5020)
2	B	12.55 – 12.65 (0.4941 – 0.4980)
3	C	12.45 – 12.55 (0.4902 – 0.4941)
4	D	12.35 – 12.45 (0.4862 – 0.4902)
5	E	12.25 – 12.35 (0.4823 – 0.4862)

- After selecting the stoppers, check that on both sides the pawl and ratchet are fully engaged.

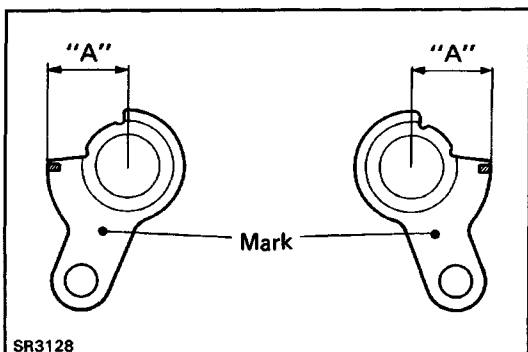

## 11. INSTALL TWO TILT LEVER RETAINERS

- Install the two tilt lever retainers and torque the nuts.  
**Torque: 15 N-m (1150 kgf-cm, 11 ft-lbf)**
- Install the E-rings.

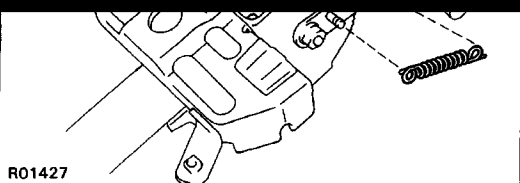
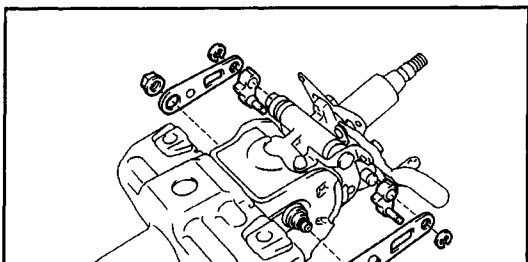

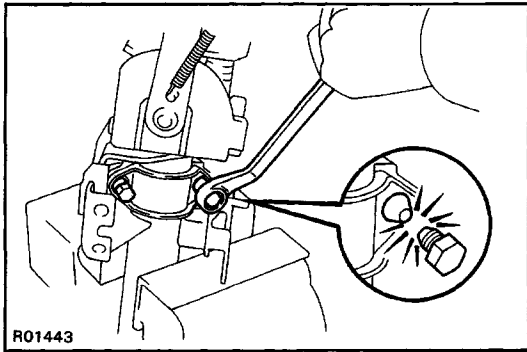
**14. INSTALL UPPER COLUMN BRACKET**

- (a) Install the upper column bracket with new two tapered-head bolts.
- (b) Tighten the tapered-head bolts until the bolt heads break off.

**15. CHECK OPERATION OF TILT STEERING LEVER AND SUPPORT**

- (a) Check that there is no axial play at the end of the main shaft.
- (b) with the main shaft in the neutral position, raise the tilt lever and check that the main shaft rises to the uppermost position.
- (c) Lower the main shaft, and check that it locks in the lowermost position.



# MANUAL GEAR HOUSING (2WD)

## REMOVAL AND INSTALLATION OF MANUAL GEAR HOUSING

Remove and install the parts as shown.

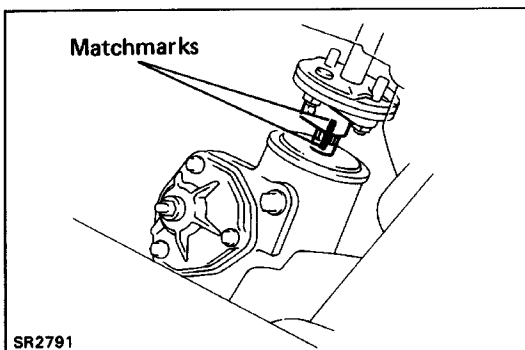
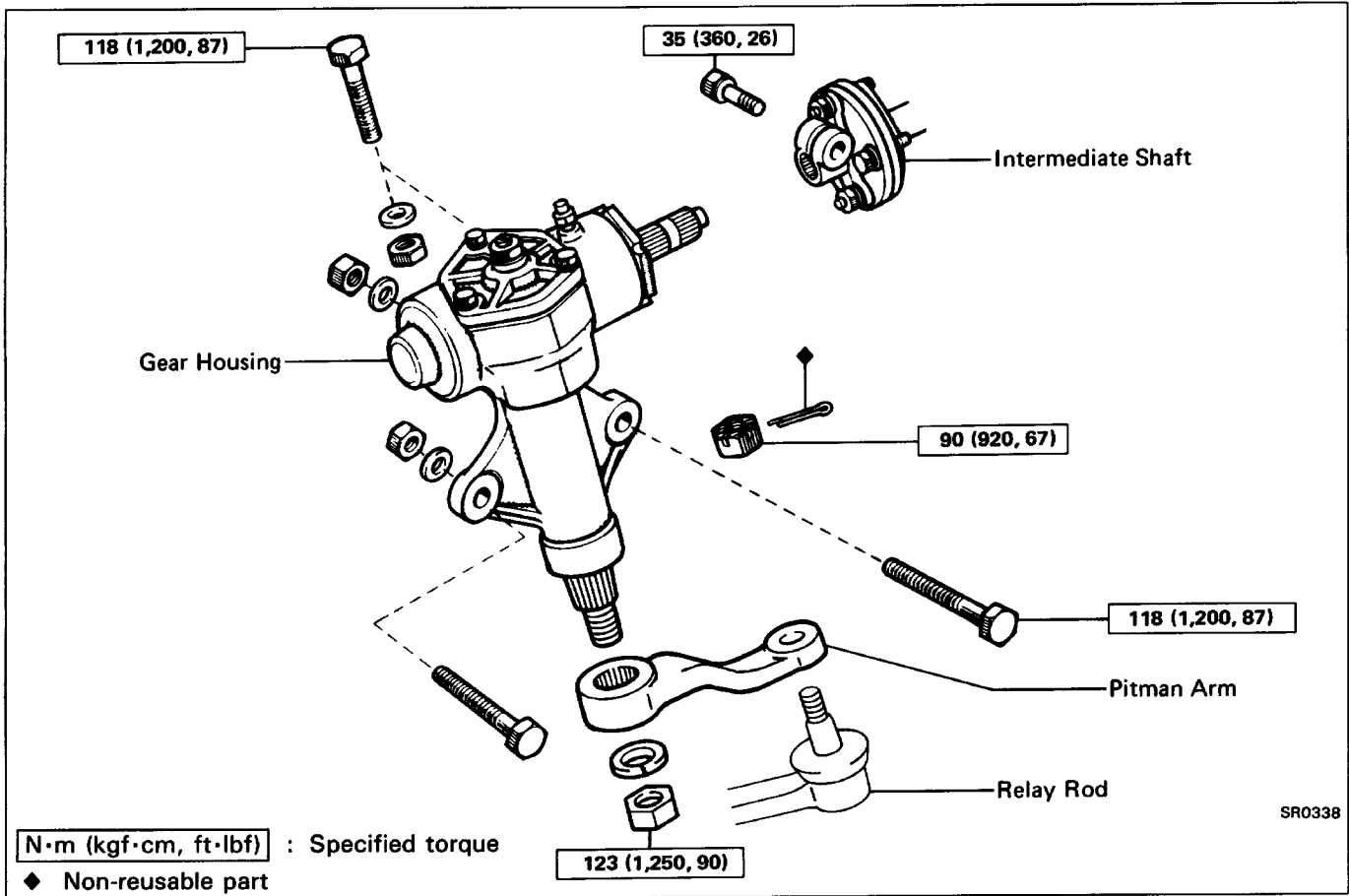

### (MAIN POINTS OF REMOVAL AND INSTALLATION)

#### 1. DISCONNECT UNIVERSAL JOINT

- Loosen the column side set bolt.
- Remove the gear side set bolt.
- Place matchmarks on the flexible coupling and worm shaft.
- Slide the shaft rearward to disconnect the shaft from the worm shaft.

#### 2. DISCONNECT PITMAN ARM FROM GEAR HOUSING

- Loosen the pitman arm nut.
- Using SST, disconnect pitman arm from the gear housing.

SST 09610-55012

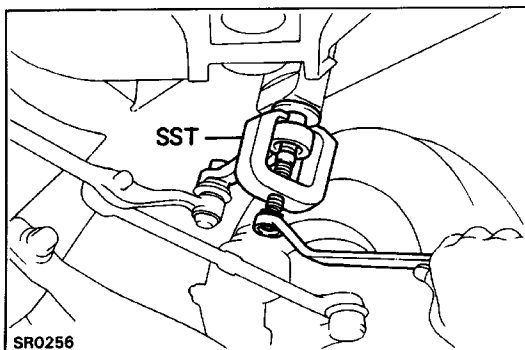

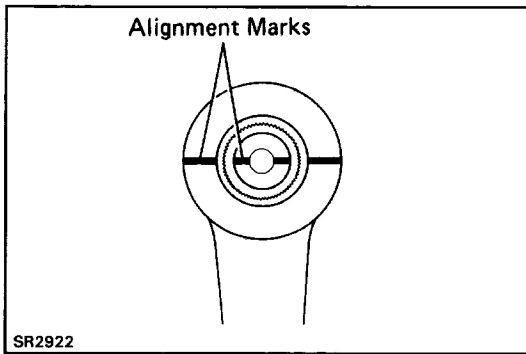

### 3. CONNECT PITMAN ARM TO GEAR HOUSING

- (a) Align the alignment marks on the sector shaft and pitman arm and install the spring washer and arm.
- (b) Tighten the pitman arm nut.

**Torque: 123 N·m (1,250 kgf·cm, 90 ft·lbf)**

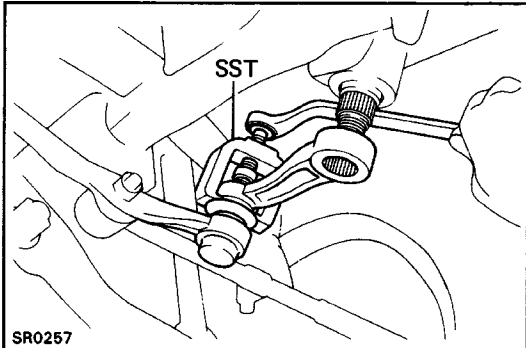

### 4. DISCONNECT PITMAN ARM FROM RELAY ROD

Using SST, disconnect the pitman arm from the relay rod.

SST 09611-22012

## COMPONENTS

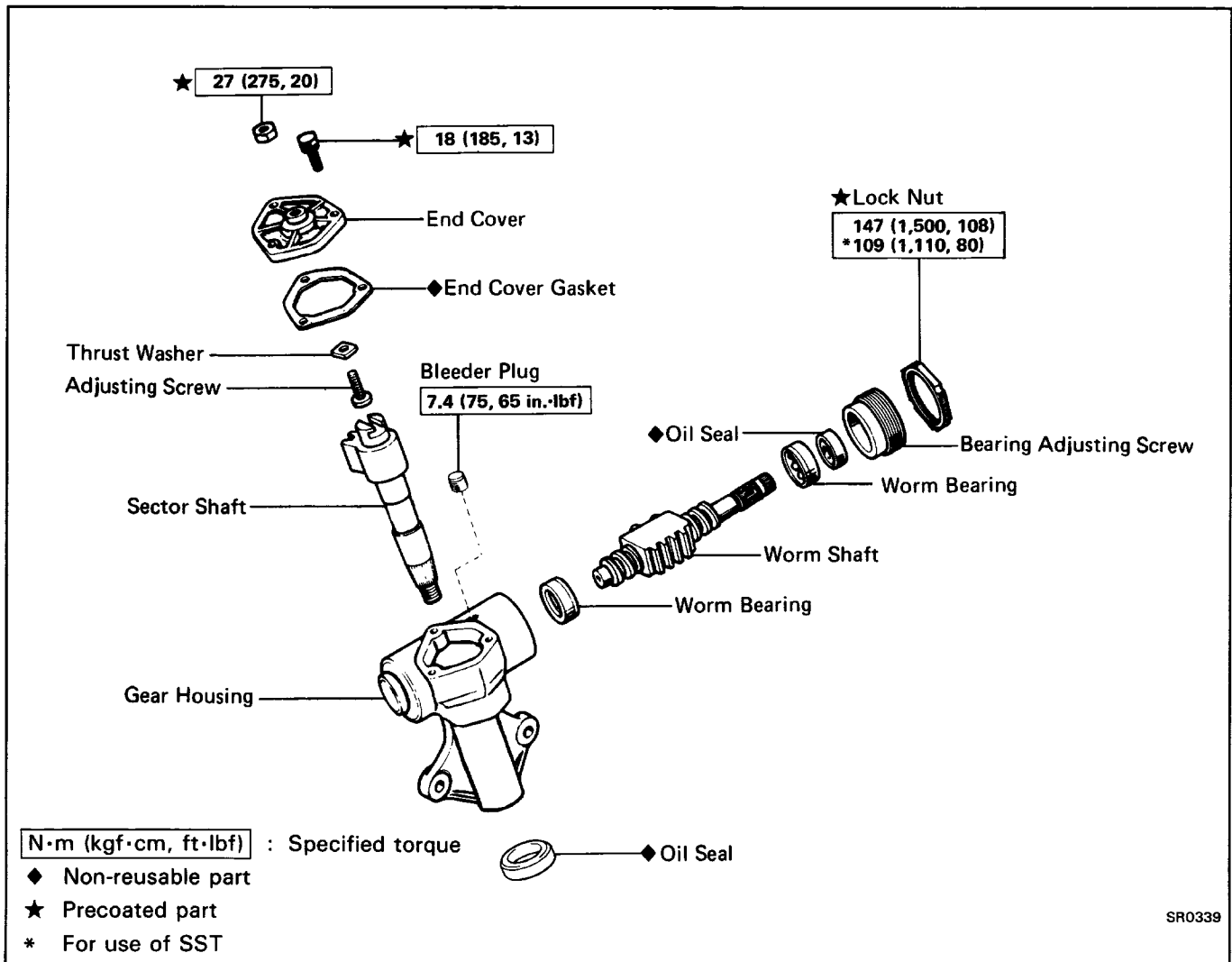

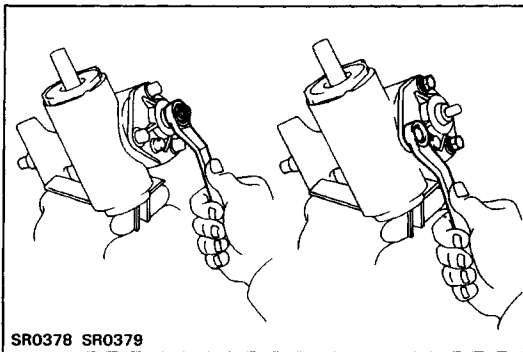
**DISASSEMBLY OF MANUAL GEAR HOUSING****1. REMOVE BLEEDER PLUG AND DRAIN GEAR OIL****2. REMOVE END COVER AND SECTOR SHAFT**

- (a) Remove the adjusting screw lock nut and three bolts.
- (b) Remove the end cover by turning the adjusting screw clockwise with a screwdriver.
- (c) Pull out the sector shaft and adjusting screw from the gear housing.

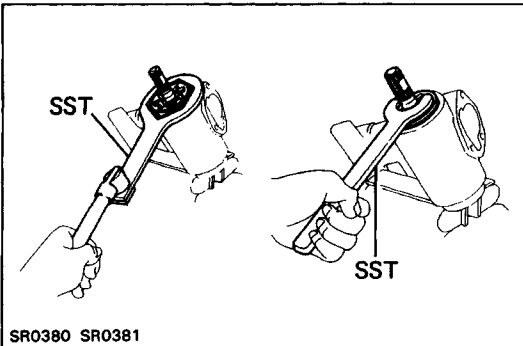
**3. REMOVE LOCK NUT**

Using SST, remove the lock nut.

SST 09617-22020

**4. REMOVE BEARING ADJUSTING SCREW**

Using SST, remove the adjusting screw.

SST 09616-30011

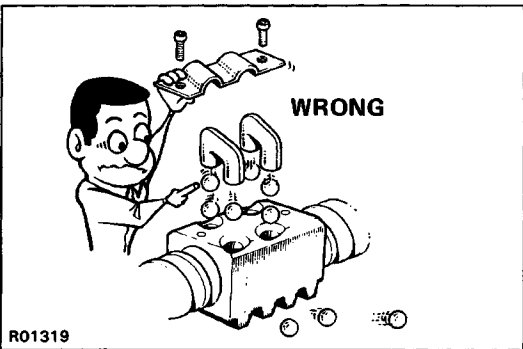
**5. REMOVE WORM SHAFT**

Pull the worm shaft out of the gear housing.

**NOTICE:** Do not disassemble the ball nut from the worm shaft.

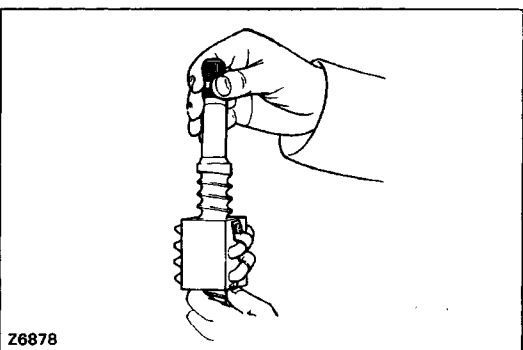
**INSPECTION AND REPLACEMENT OF MANUAL GEAR HOUSING****1. INSPECT WORM AND BALL NUT**

- (a) Check the worm and ball nut for wear or damage.
  - (b) Check that the nut rotates smoothly down the shaft by its own weight.
- If a problem is found, repair or replace the worm.

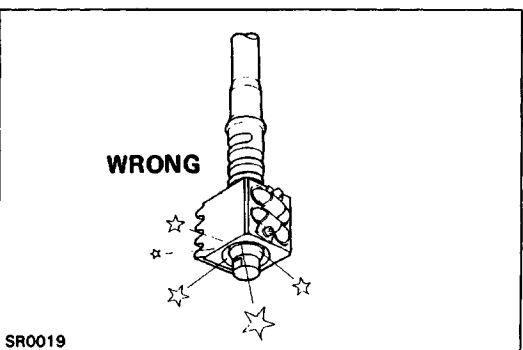

**NOTICE:** Do not allow the ball nut to hit the end of the worm shaft.

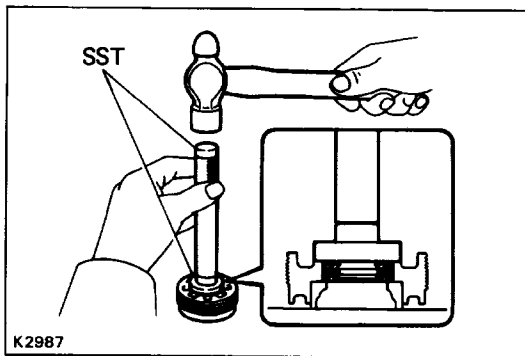

## 2. INSPECT WORM BEARINGS AND OIL SEAL

Check for wear or damage.

If a problem is found, replace the bearings, bearing races and oil seal.

## 3. IF NECESSARY, REPLACE OIL SEAL

(a) Remove the oil seal with a screwdriver.

(b) Using SST, install a new oil seal.

SST 09620-30010 (09627-30010, 09631-00020)

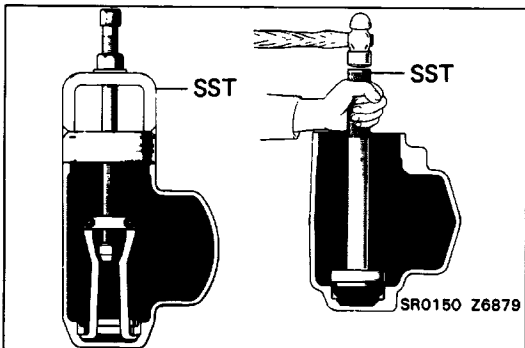

## 4. IF NECESSARY, REPLACE OUTER RACE IN GEAR HOUSING

(a) Using SST, remove the outer race from the housing.

SST 09612-65014 (09612-01030)

(b) Using SST, install a new outer race into the housing.

SST 09620-30010 (09626-30010, 09631-00020)

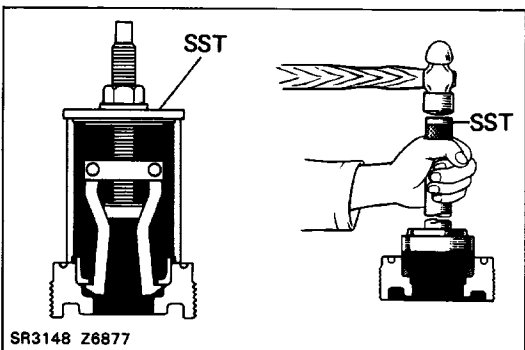

## 5. IF NECESSARY, REPLACE OUTER RACE 1N ADJUSTING NUT

(a) Remove the oil seal with a screwdriver.

(b) Using SST, remove the outer race from the nut.

SST 09612-30012

(c) Using SST, install a new race into the nut.

SST 09620-30010 (09626-30010, 09631-00020)

(d) Using SST, install a new oil seal into the nut.

SST 09620-30010 (09627-30010, 09631-00020)

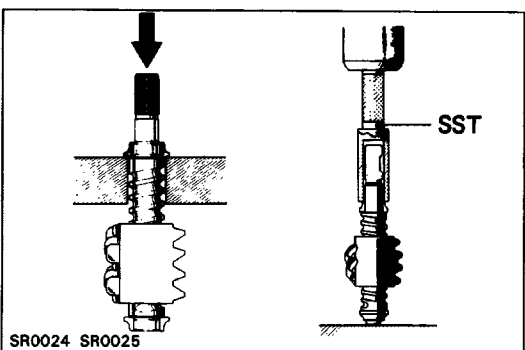

## 6. IF NECESSARY, REPLACE INNER RACE ON WORM SHAFT

(a) Using a press, remove the inner races from the shaft.

(b) Using SST, press new inner races onto the shaft.

SST 09620-30010 (09623-30010)

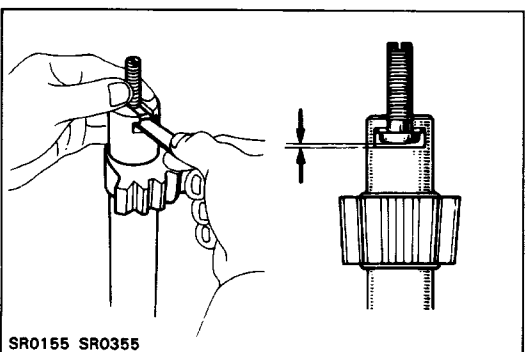

## 7. INSPECT SECTOR SHAFT

Measure shaft thrust clearance with a feeler gauge.

**Maximum clearance: 0.05 mm (0.0020 in.) or less**

If necessary, install a new thrust washer which will provide the minimum clearance between the sector shaft and the adjusting screw.

Thrust washer thickness

Thickness mm (in.)		Thickness mm (in.)	
1.95	(0.0768)	2.10	(0.0827)
2.00	(0.0787)	2.15	(0.0847)
2.05	(0.0807)		

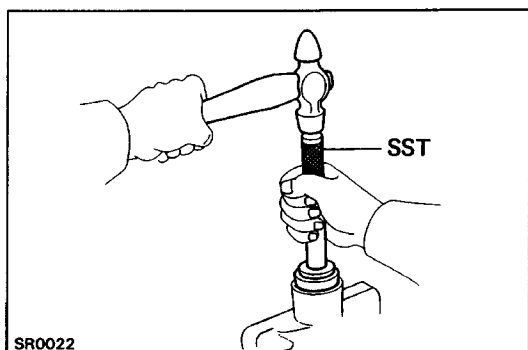

### 8. IF NECESSARY, REPLACE OIL SEAL

- Remove the oil seal with a screwdriver from the gear housing.
- Using SST and a hammer, install a new oil seal.  
SST 09630-00012 (09631-00020, 09631-00090)

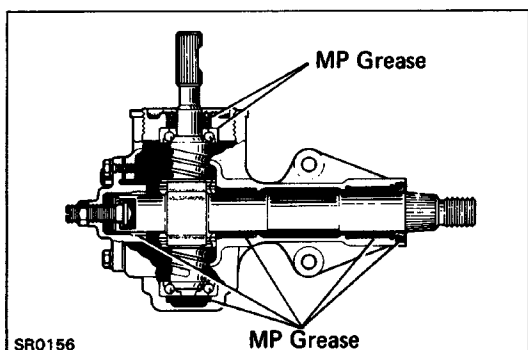

### ASSEMBLY OF STEERING GEAR HOUSING

(See page [SR-19](#))

#### 1. APPLY MP GREASE TO BUSHING, NEEDLE ROLLER BEARING AND OIL SEALS

#### 2. INSTALL WORM SHAFT INTO GEAR HOUSING

Place the worm bearings on the shaft and install the shaft into the housing.

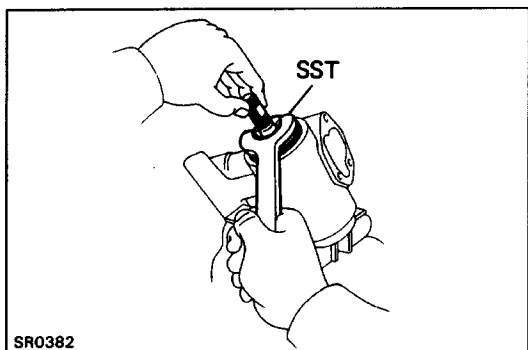

#### 3. INSTALL AND ADJUST BEARING ADJUSTING SCREW

- Using SST, gradually tighten the adjusting screw until it is snug.  
SST 09616-30020

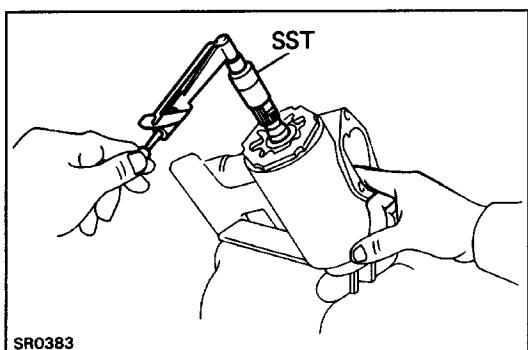

- Using a torque meter and SST, measure the bearing preload in both directions. Turn the adjusting screw until the preload is correct.

**Preload (Starting): 0.3 – 0.5 N-m**

**(3 – 5 kgf-cm, 2.6 – 4.3 in.-lbf)**

SST 09616-00010

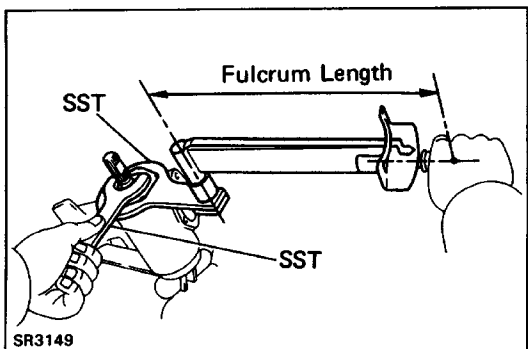

- Apply sealant to the lock nut.

**Sealant: Part No.08833-00080, THREE BOND 1344, LOCTITE 242 or equivalent**

- Hold the adjusting screw in position with SST and tighten the lock nut with SST.

**Torque: 147 N-m (1,500 kgf-cm, 108 ft-lbf)**

SST 09616-30011 and 09617-22020

HINT:

- Check that the bearing preload is still correct.
- Use a torque wrench with a fulcrum length of 425 mm (16.73 in.).

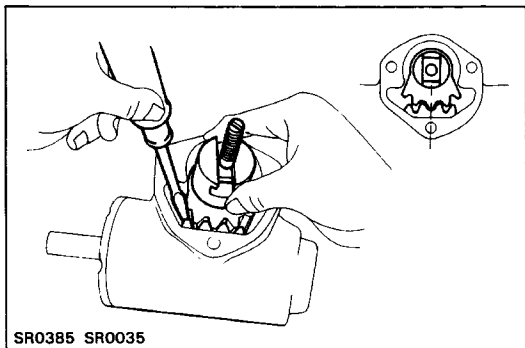

#### 4. INSTALL SECTOR SHAFT

- Install the adjusting screw and thrust washer onto the sector shaft.
- Set the ball nut at the center of the worm shaft. Install the sector shaft into the gear housing so that the center teeth mesh together.

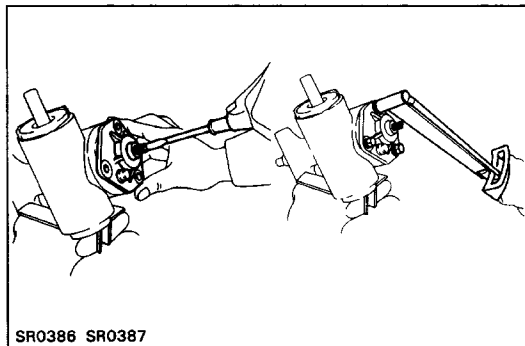

#### 5. INSTALL END COVER

- Install the end cover over a new gasket.
- Using a screwdriver, loosen the adjusting screw as far as possible.
- Apply sealant to the bleeder plug side cover bolt.  
**Sealant: Part No. 08833-00080, THREE BOND 1344, LOCTITE 242 or equivalent**
- Torque the three cover bolts.  
**Torque: 18 N-m (185 kgf-cm, 13 ft-lbf)**

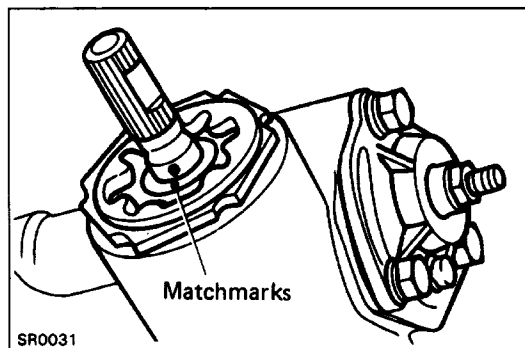

#### 6. PLACE WORM SHAFT IN NEUTRAL POSITION

- Count the total shaft rotations and turn the shaft back half of that number.
- The worm shaft is now in neutral position.
- Place matchmarks on the worm shaft and housing to show neutral position.

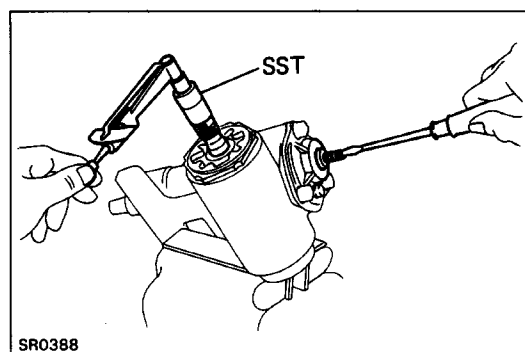

#### 7. ADJUST TOTAL PRELOAD

Using a torque meter and SST, turn the adjusting screw while measuring the preload until it is correct.

HINT: Be sure that the worm shaft is in neutral position.

**Preload (Starting): 0.8 – 1.0 N-m**

**(8 – 10.5 kgf-cm, 6.9 – 9.1 in.-lbf)**

SST 09616-00010

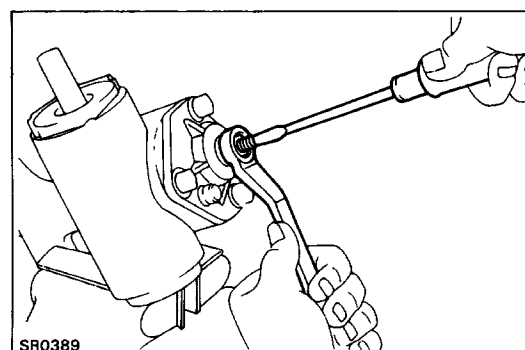

#### 8. TIGHTEN ADJUSTING SCREW LOCK NUT

- Apply sealant to the lock nut.  
**Sealant: Part No. 08833-00080, THREE BOND 1344, LOCTITE 242 or equivalent**
- Hold the screw with a screwdriver while tightening the lock nut.
- Torque the lock nut.  
**Torque: 27 N-m (275 kgf-cm, 20 ft-lbf)**  
HINT: Check that the preload is still correct.

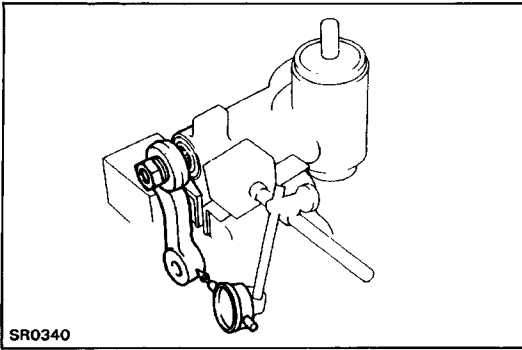

### 9. MEASURE SECTOR SHAFT BACKLASH

Install a dial indicator. Check that the sector shaft has no backlash within 100 degrees of the left and right sides from neutral position.

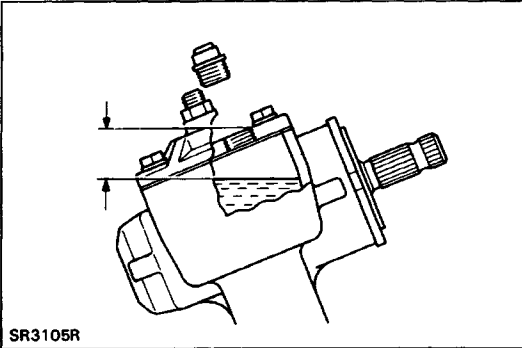

### 10. REPLENISH WITH GEAR OIL

Oil type: API GL-4, SAE 90

Capacity: 380 - 400 cc (23.2 - 24.4 cu in.)

Oil level: (at installation)

18 - 28 mm (0-71 - 1.10 in.) from top

### 11. INSTALL BLEEDER PLUG

Torque: 7.4 N-m (75 kgf-cm, 65 in.-lbf)

# MANUAL GEAR HOUSING (4WD)

## REMOVAL AND INSTALLATION OF MANUAL GEAR HOUSING

Remove and install the parts as shown.

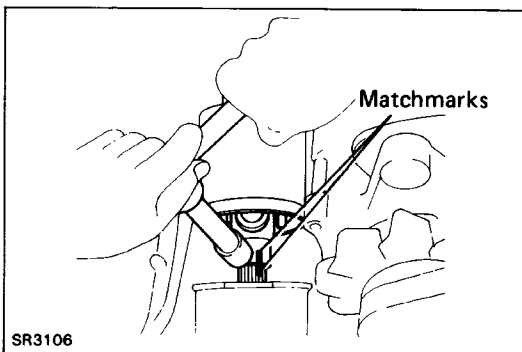
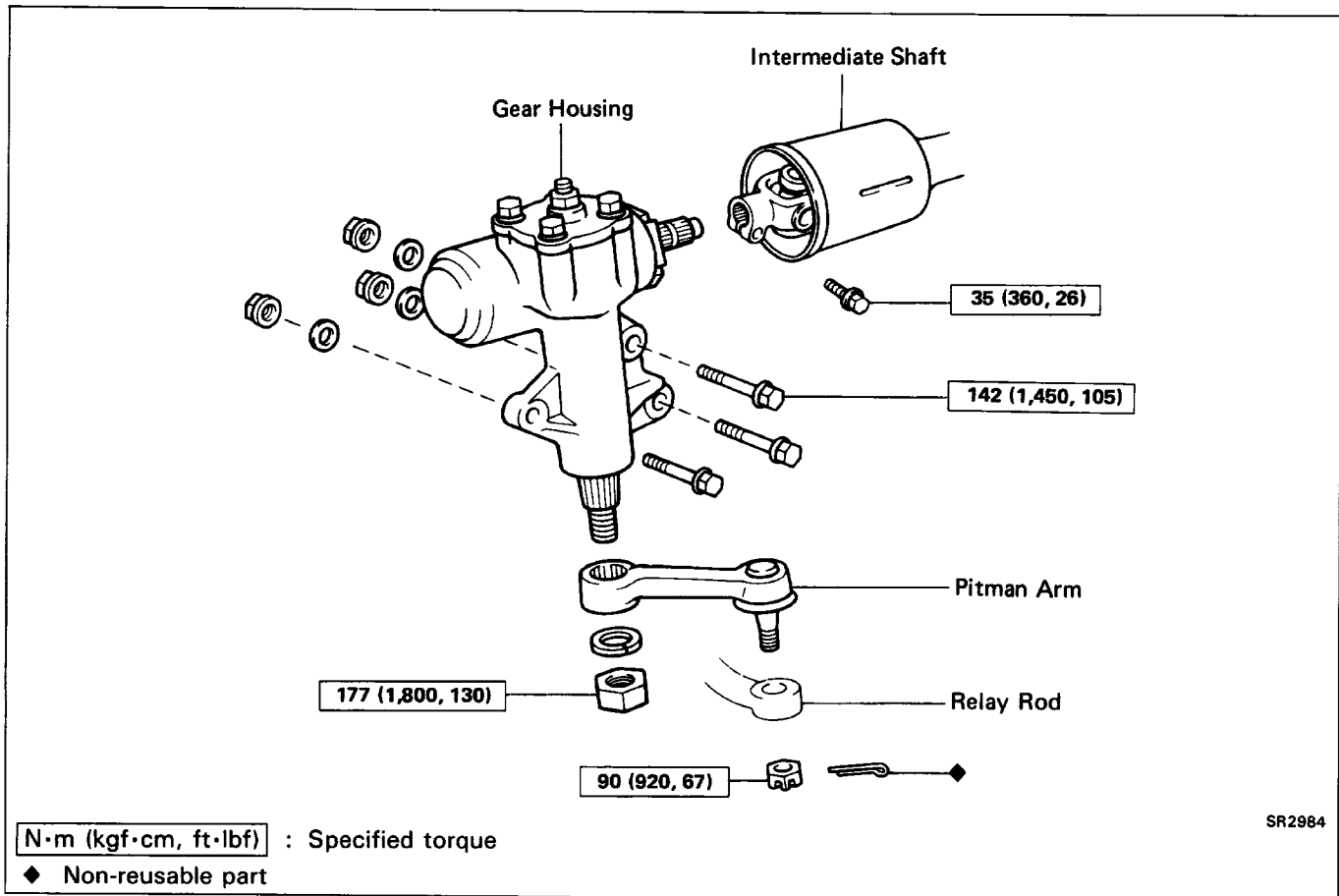

### (MAIN POINTS OF REMOVAL AND INSTALLATION)

#### 1. DISCONNECT UNIVERSAL JOINT

- (a) Loosen the column side set bolt.
- (b) Remove the gear side set bolt.
- (e) Place matchmarks on the universal joint and worm shaft.
- (d) Slide the shaft rearward to disconnect the shaft from the worm shaft.

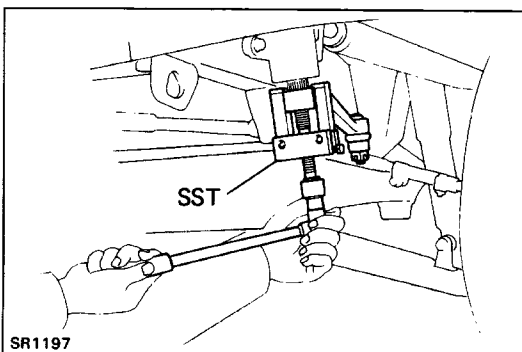

#### 2. DISCONNECT PITMAN ARM FROM GEAR HOUSING

- (a) Loosen the pitman arm set nut.
- (b) Using SST, disconnect the pitman arm from the gear housing.

SST 09628-62011



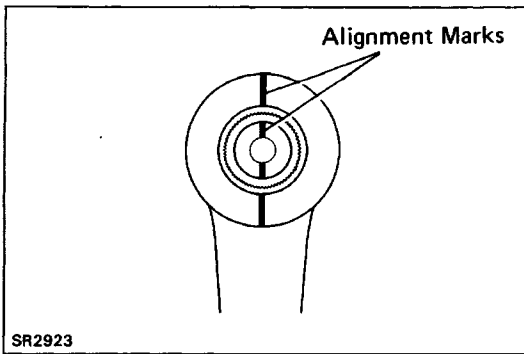

**3. CONNECT PITMAN ARM TO GEAR HOUSING**

Align alignment marks on the pitman arm and the sector shaft, and install the spring washer and nut.

**Torque: 177 N·m (1,800 kgf·cm, 130 ft·lbf)**

SR2923

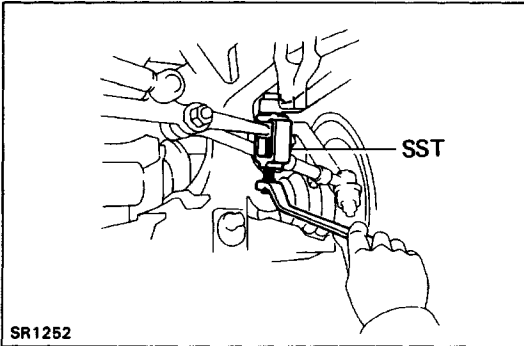

**4. DISCONNECT PITMAN ARM FROM RELAY ROD**

(a) Remove the cotter pin and set nut.

(b) Using SST, disconnect the pitman arm from the relay rod.

SST 09611-22012

SR1252

**COMPONENTS**

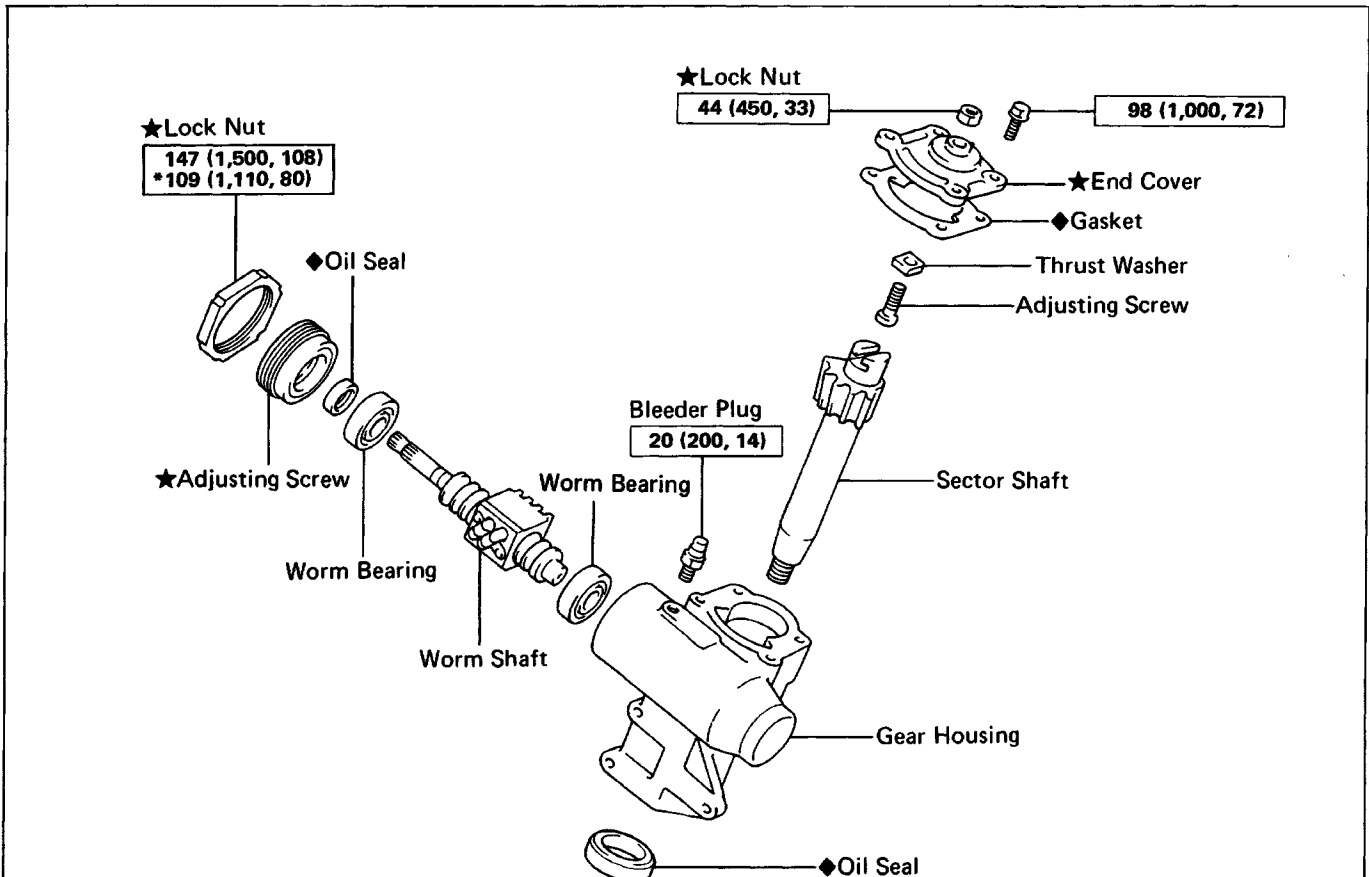

**N·m (kgf·cm, ft·lbf)** : Specified torque

- ◆ Non-reusable part
- ★ Precoated part
- \* For use of SST

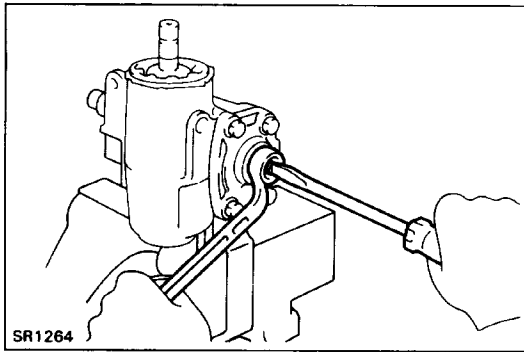

## DISASSEMBLY OF MANUAL GEAR HOUSING

### 1. REMOVE BLEEDER PLUG AND DRAIN GEAR OIL

### 2. REMOVE END COVER

(a) Remove the adjusting screw lock nut and four bolts.

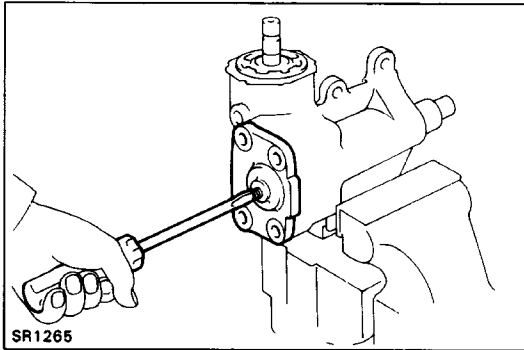

(b) Remove the end cover by turning the adjusting screw clockwise.

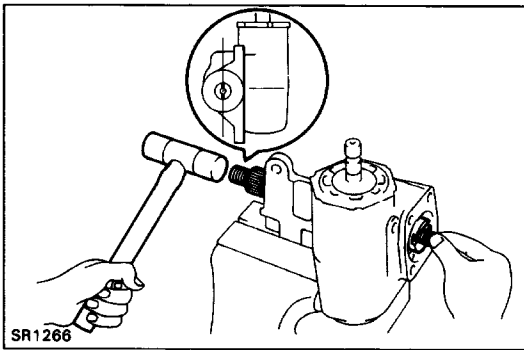

### 3. REMOVE SECTOR SHAFT

(a) Using a plastic hammer, tap out the sector shaft.

(b) Remove the sector shaft.

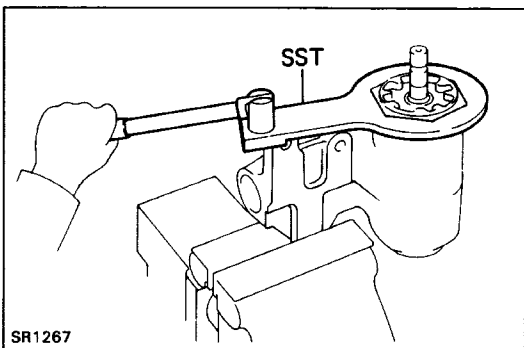

### 4. REMOVE WORM BEARING ADJUSTING SCREW LOCK NUT

Using SST, remove the lock nut.

SST 09617-60010

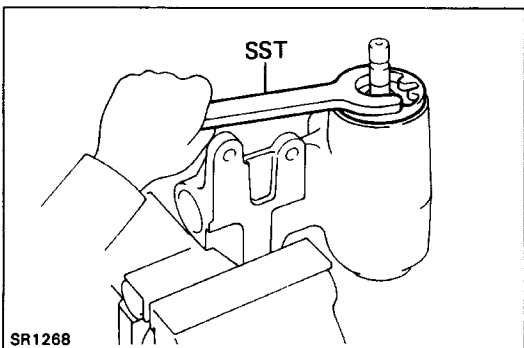

### 5. REMOVE WORM BEARING ADJUSTING SCREW

Using SST, remove the adjusting screw.

SST 09616-22010

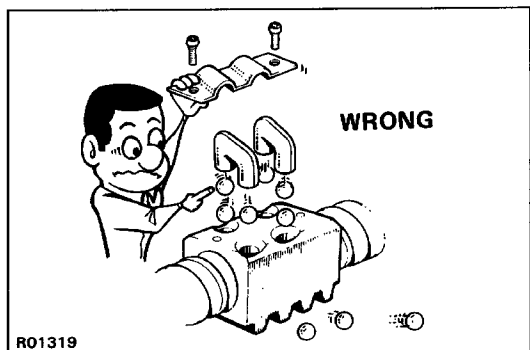

## 6. REMOVE WORM SHAFT

Pull the worm shaft out of the gear housing.

**NOTICE:** Do not disassemble the ball nut from the worm shaft.

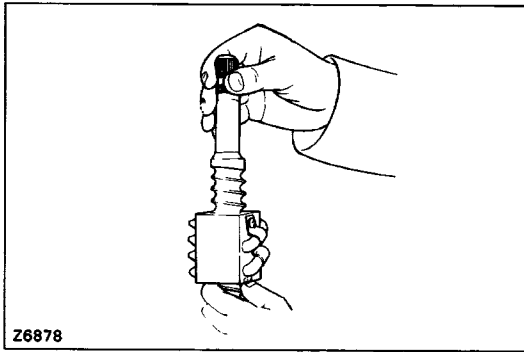

## INSPECTION AND REPLACEMENT OF MANUAL GEAR HOUSING

### 1. INSPECT WORM AND BALL NUT

- (a) Check the worm and ball nut for wear or damage.
- (b) Check that the nut rotates smoothly down the shaft by its own weight.

If a problem is found, repair or replace the worm.

**NOTICE:** Do not allow the ball nut to hit the end of the worm shaft.

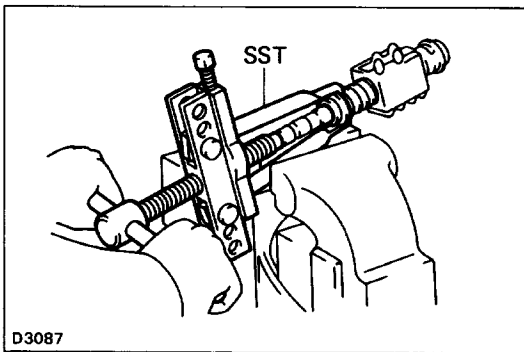
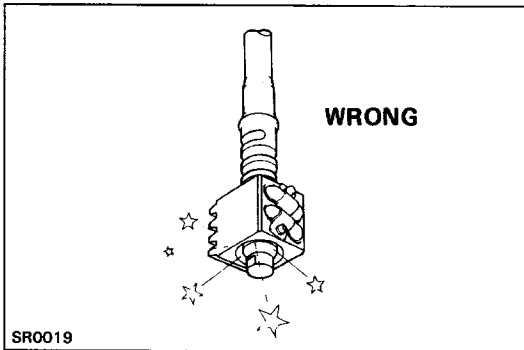

### 2. IF NECESSARY, REPLACE WORM BEARING INNER RACE

- (a) Using SST, remove the both side bearing inner races.

SST 09950-20017

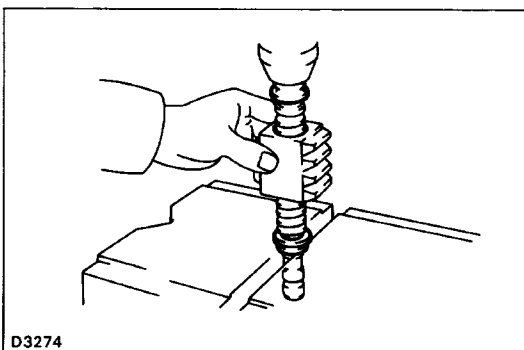
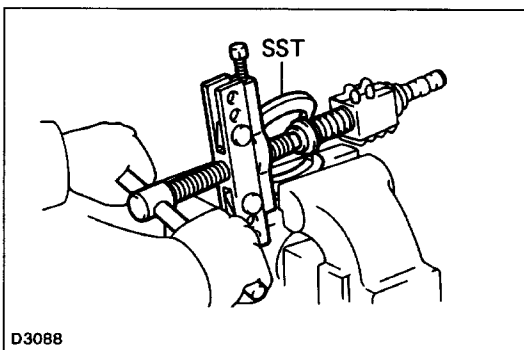

- (b) Using a press, install new bearing inner races.
 

**NOTICE:** Be careful not to damage the ball nut while holding it with hand.

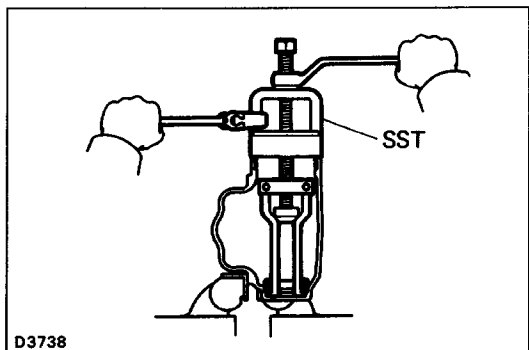

- (c) Using SST, remove the outer race from the gear housing.  
SST 09612-65014 (09612-01030)

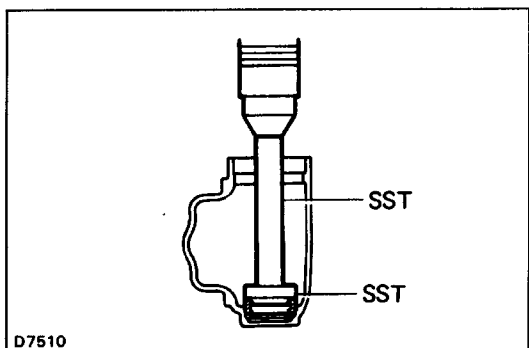

- (d) Using SST, press in a new outer race into the gear housing.  
SST 09550-10012 (09552-10010, 09559-10010)

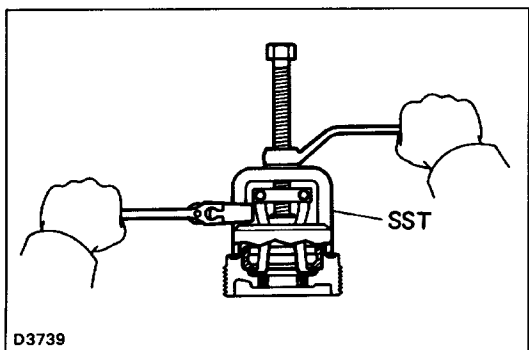

- (e) Using SST, remove the outer race from the adjusting screw.  
SST 09612-65014 (09612-01040)

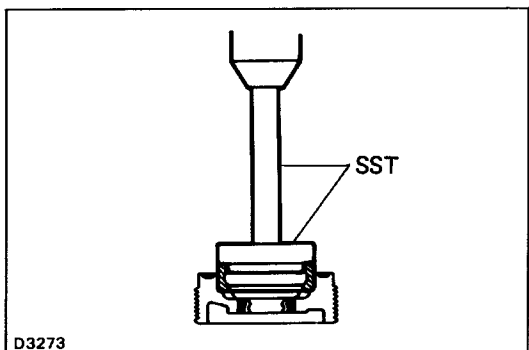

- (f) Using SST, press in a new outer race into the adjusting screw.  
SST 09550-10012 (09552-10010, 09559-10010)

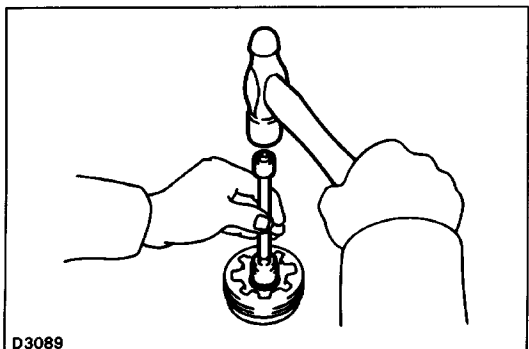

### 3. IF NECESSARY, REPLACE ADJUSTING SCREW OIL SEAL

- (a) Using a socket wrench, drive out the oil seal.

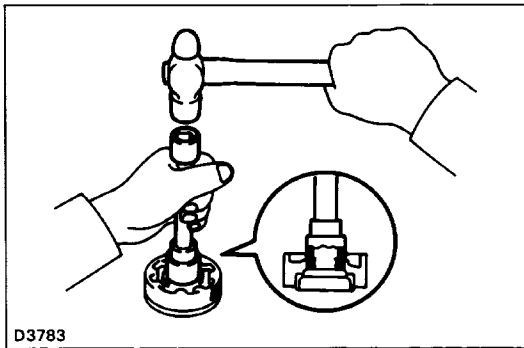

(b) Using a socket wrench, drive in a new oil seal.

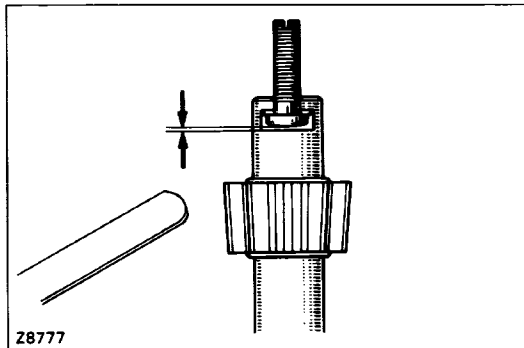

#### 4. MEASURE SECTOR SHAFT THRUST CLEARANCE

Using a feeler gauge, measure the shaft thrust clearance.

**Maximum clearance: 0.05 mm (0.0020 in.) or less**

If necessary, install a new thrust washer to provide the minimum clearance between the sector shaft and adjusting screw.

Thrust washer thickness mm (in.)			
1.95	(0.0768)	2.05	(0.0807)
2.00	(0.0787)		

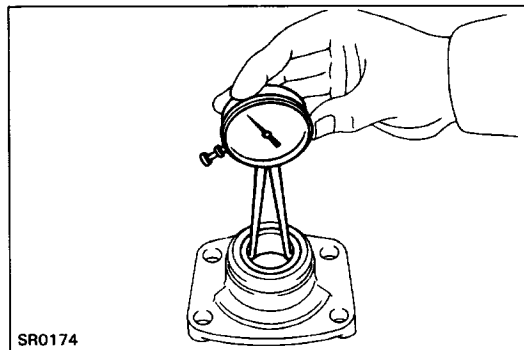

#### 5. INSPECT SECTOR SHAFT END COVER

(a) Check for damage.

(b) Check the bushing for wear or damage.

(c) Measure the bushing inside diameter.

**Maximum inside diameter: 36.07 mm (1.4201 in.)**

If necessary, replace the end cover.

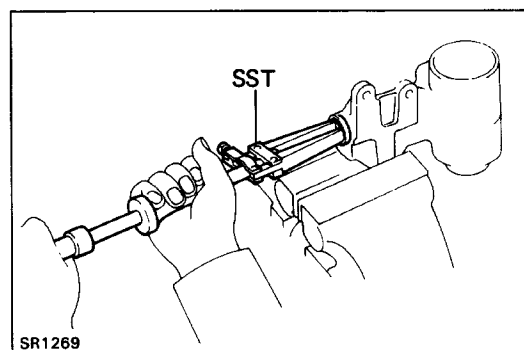

#### 6. IF NECESSARY, REPLACE GEAR HOUSING OIL SEAL

(a) Using SST, remove the oil seal.

SST 09308-00010

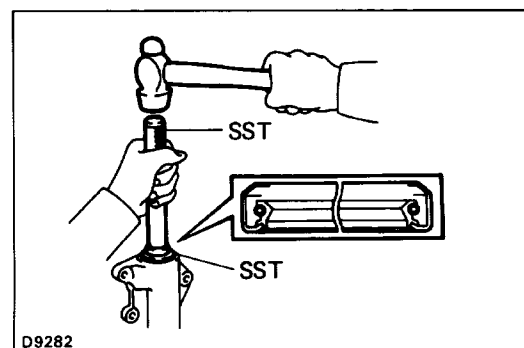

(b) Using SST, drive in a new oil seal.

SST 09550-10012 (09552-10010, 09558-10010)

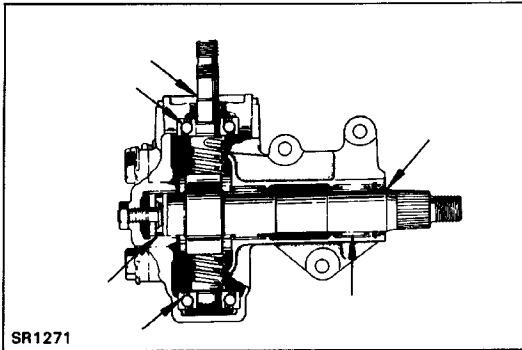

## ASSEMBLY OF MANUAL GEAR HOUSING

(See page [SR-27](#))

### 1. APPLY MP GREASE TO BUSHING, NEEDLE ROLLER BEARING AND OIL SEALS

### 2. INSTALL WORM SHAFT INTO GEAR HOUSING

Place the worm bearing on the shaft and install the shaft into the housing.

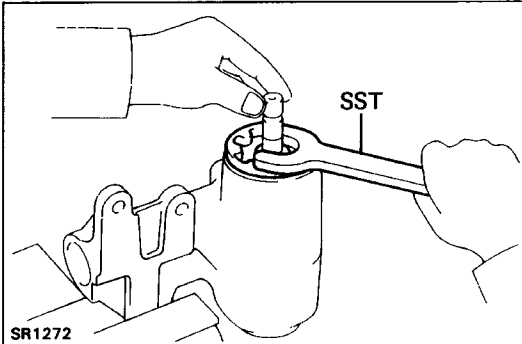

### 3. INSTALL AND ADJUST BEARING ADJUSTING SCREW

(a) Apply sealant to the adjusting screw.

**Sealant: Part No. 08833-00080, THREE BOND 1344, LOCTITE 242 or equivalent**

(b) Using SST, gradually tighten the adjusting screw until it is snug.

SST 09616-22010

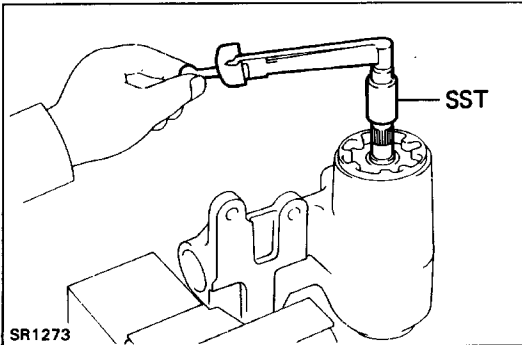

(c) Using a torque meter and SST, measure the bearing preload in both directions. Turn the adjusting screw until the preload is correct.

**Preload (Starting):**

**0.3 – 0.5 N-m**

**(3.5 – 5.0 kgf-cm, 3.0 – 4.3 in.-lbf)**

SST 09616-00010

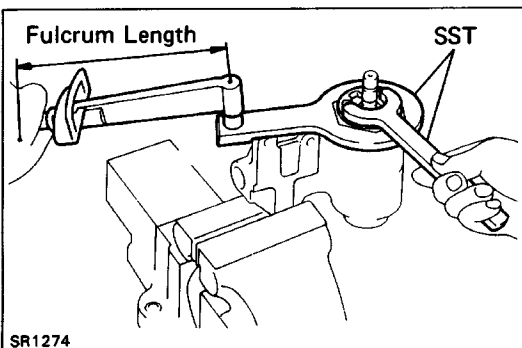

(d) Apply sealant to the lock nut.

**Sealant: Part No. 08833-00080, THREE BOND 1344, LOCTITE 242 or equivalent**

(e) Hold the adjusting screw in position with SST and tighten the lock nut with SST.

**Torque: 109 N-m (1,110 kgf-cm, 80 ft-lbf)**

SST 09616-22010, 09617-60010

**HINT:**

- Check that the bearing preload is still correct.
- Use a torque wrench with a fulcrum length of 425 mm (16.73 in.).

### 4. INSTALL SECTOR SHAFT

(a) Install the adjusting screw and thrust washer onto the sector shaft.

(b) Set the ball nut at the center of the worm shaft. Install the sector shaft into the gear housing so that the center teeth mesh together.

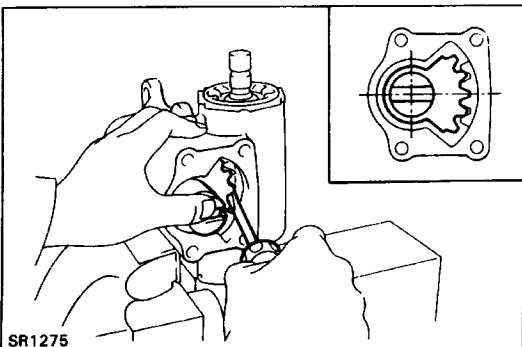

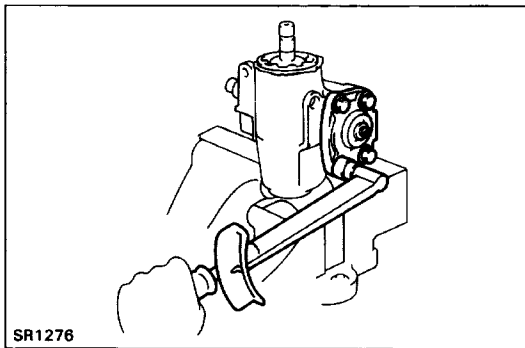

## 5. INSTALL END COVER

- Apply sealant to new gasket and end cover.  
**Sealant: Part No. 08833-00080, THREE BOND 1344, LOCTITE 242 or equivalent**
- Install the end cover over the gasket.
- Loosen the adjusting screw as far as possible.
- Torque the four cover bolts.  
**Torque: 98 N-m (1,000 kgf-cm, 72 ft-lbf)**

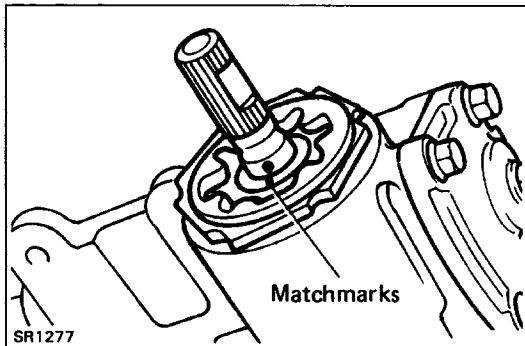

## 6. PLACE WORM SHAFT IN NEUTRAL POSITION

- Count the total shaft rotation and turn the shaft back half of that number.
- The worm shaft is now in neutral position.
- Place matchmarks on the worm shaft and housing to show neutral position.

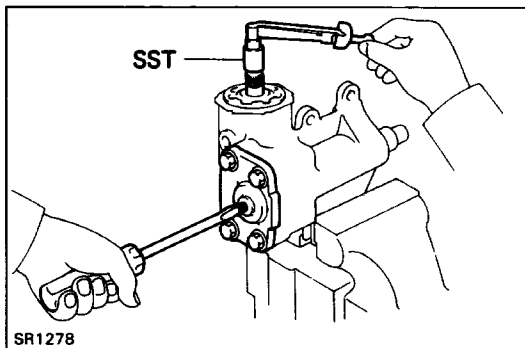

## 7. ADJUST TOTAL PRELOAD

Using a torque meter and SST, turn the adjusting screw while measuring the preload until the preload is correct.  
**HINT:** Be sure that the worm shaft is in neutral position.

### Preload (Starting):

**0.8 – 1.1 N-m**

**(8.0 – 11.0 kgf-cm, 6.9 – 9.5 in. AM)**

SST 09616-00010

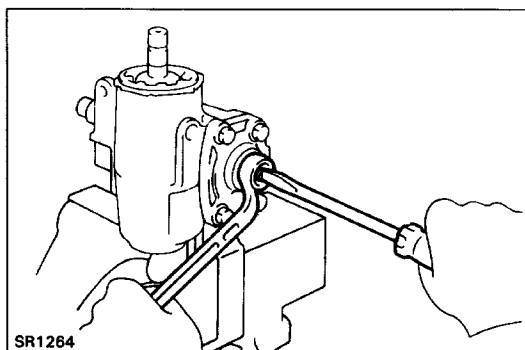

## 8. TIGHTEN ADJUSTING SCREW LOCK NUT

- Apply sealant to the lock nut.  
**Sealant: Part No. 08833-00080, THREE BOND 1344, LOCTITE 242 or equivalent**
- Hold the screw with a screwdriver while tightening the lock nut.
- Torque the lock nut.  
**Torque: 44 N-m (450 kgf-cm, 33 ft-lbf)**  
**HINT:** Check that the preload is still correct.

## 9. MEASURE SECTOR SHAFT BACKLASH

- Align the alignment marks on the sector shaft with the pitman arm.
- Check that the sector shaft has no backlash within 100 degrees of the left and right side from neutral position.

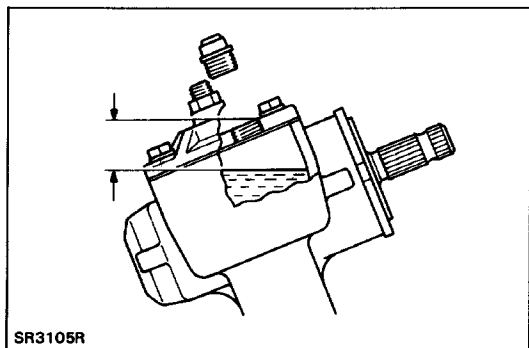

**10. REPLENISH WITH GEAR OIL**

Oil type: API GL-4, SAE 90

Capacity: 400 cc (24.4 cu in.)

Oil level: (at installation)

14 – 17 mm (0.55 – 0.67 in.) from top

**11. INSTALL BLEEDER PLUG**

Torque: 20 N-m (200 kgf-cm, 14 ft-lbf)

# POWER STEERING

## Description

Two types of power steering are the standard type and the PPS (progressive power steering) type. Both these types have a recirculating ball system and rotary type hydraulic control valve.

## PPS TYPE

Vehicle speed is detected by a speed sensor and fluid pressure acting on the piston is varied accordingly. When the vehicle is stopped or when moving at low speed, fluid pressure is increased to lighten the force required for steering. At high speed, pressure is reduced to lessen the amount of assist and provide appropriate steering wheel response.

### Standard Type

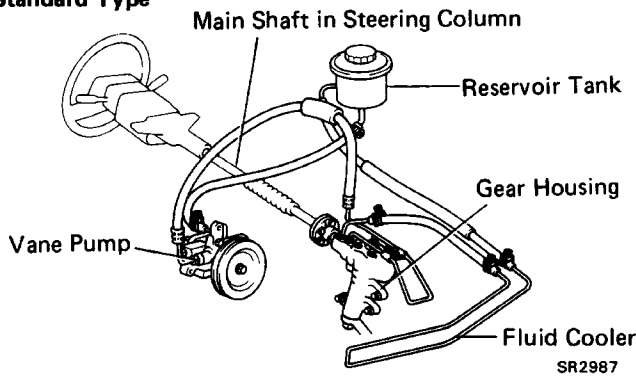

### PPS (Progressive Power Steering) Type

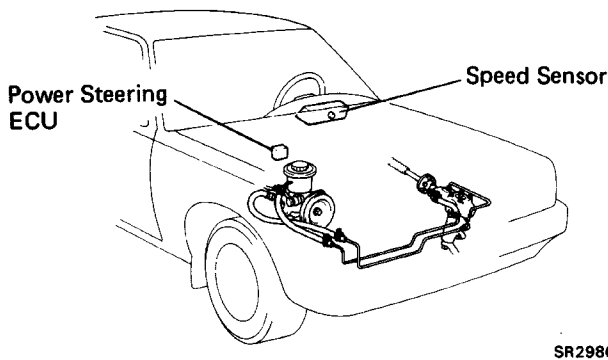

## PRINCIPLES OF POWER STEERING

Power steering is one type of hydraulic device for utilizing engine power to reduce steering effort. Consequently, the engine is used to drive a pump to develop fluid pressure, and this pressure acts on a piston within the gear box so that the piston assists the sector shaft effort. The amount of this assistance depends on the extent of pressure acting on the piston. Therefore, if more steering force is required, the pressure must be raised. The variation in the fluid pressure is accomplished by a control valve which is linked to the intermediate shaft and the steering main shaft.

## NEUTRAL (STRAIGHT-AHEAD) POSITION

Fluid from the pump is sent to the control valve. If the control valve is in the neutral position, all the fluid will flow through the control valve into the relief port and back to the pump. At this time, hardly any pressure is created and because the pressure on the power piston is equal on both sides, the piston will not move in either direction.

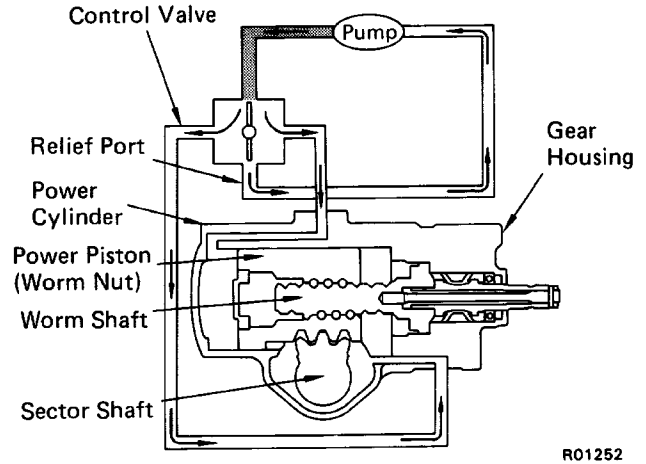

## WHEN TURNING

When the steering main shaft is turned in either direction, the control valve also moves, closing one of the fluid passages. The other passage then opens wider, causing a change in fluid flow volume and, at the same time, pressure is created. Consequently, a pressure difference occurs between both sides of the piston and the piston moves in the direction of the lower pressure so that the fluid in the cylinder is forced back to the pump through the control valve.

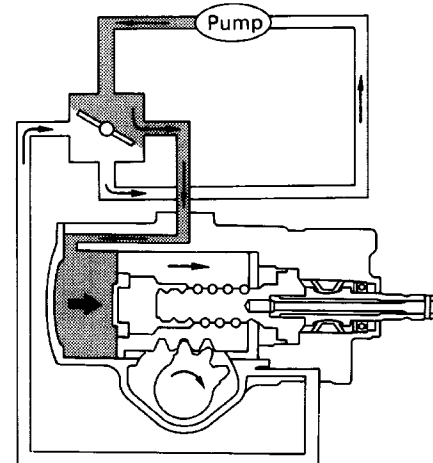

## SERVICE HINT

Troubles with the power steering system are usually concerned with hard steering due to the fact that there is no assist. In such cases, before attempting to make repairs, it is necessary to determine whether the trouble lies with the pump or with the gear housing. To do this, an on-vehicle inspection can be made by using a pressure gauge.

## ON-VEHICLE INSPECTION

Power steering is a hydraulic device and problems are normally due to insufficient fluid pressure acting on the piston. This could be caused by either the pump not producing the specified fluid pressure or the control valve in the gear housing not functioning properly so that the proper fluid pressure can not be obtained.

If the fault lies with the pump, the same symptoms will generally occur whether the steering wheel is turned fully to the right or left. On the other hand, if the fault lies with the control valve, there will generally be a difference between the amount of assist when the steering wheel is turned to the left and right, causing harder steering. However, if the piston seal of the power cylinder is worn, there will be a loss of fluid pressure whether the steering wheel is turned to the right or left and the symptoms will be the same for both.

Before performing an on-vehicle inspection, a check must first be made to confirm that the power steering system is completely free of any air. If there is any air in the system, the volume of this air will change when the fluid pressure is raised, causing a fluctuation in the fluid pressure so that the power steering will not function properly. To determine if there is any air in the system, check to see if there is a change of fluid level in the reservoir tank when the steering wheel is turned fully to the right or left.

For example, if there is air in the system, it will be compressed to a smaller volume when the steering wheel is turned, causing a considerable drop in the fluid level. If the system is free of air, there will be very little change in the level even when the fluid pressure is raised. This is because the fluid, being a liquid, does not change volume when compressed. The little change in the fluid level is due to expansion of the hoses between the pump and gear housing when pressure rises.

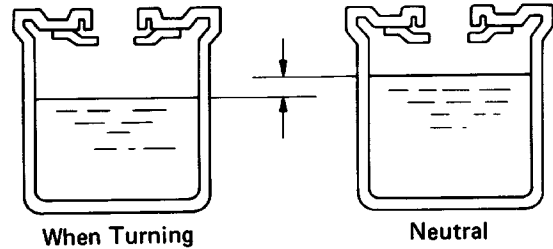

SR2392

SR2393

Also, air in the system will sometimes result in an abnormal noise occurring from the pump or gear housing when the steering wheel is fully turned in either direction.

This on-vehicle inspection must be performed every time to ensure that the power steering system is working properly after overhauling or repairing the pump or gear housing.

## VANE PUMP

The main component parts of the vane pump, such as the cam ring, rotor, vanes and flow control valve are high precision parts and must be handled carefully. Also, because this pump produces a very high fluid pressure, O-rings are used for sealing each part. When reassembling the pump, always use new O-rings.

In the flow control valve, there is a relief valve which controls the maximum pressure of the pump. The amount of this maximum pressure is very important; if it is too low, there will be insufficient power steering assist and if too high, it will have an adverse effect on the pressure hoses, oil seals, etc.. If the maximum pressure is either too high or too low due to a faulty relief valve, do not disassemble or adjust the relief valve, but replace the flow control valve as an assembly.

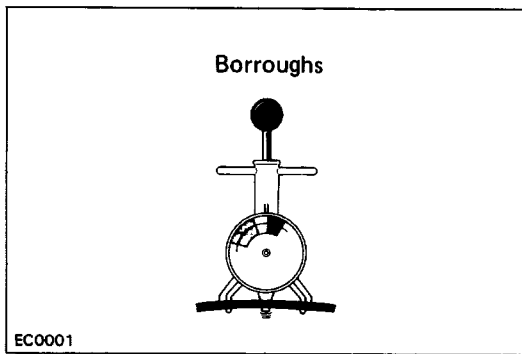

## On-Vehicle Inspection

### CHECK DRIVE BELT TENSION

Using a belt tension gauge, check the drive belt tension.

**Belt tension gauge:**

**Nippondenso BTG-20 (95506-00020) or**

**Borroughs No. BT-33-73F**

**Drive belt tension:**

**New belt**      441 – 667 N-m  
(45 – 68 kgf, 100 – 150 lbf)

**Used belt**     265 – 441 N-m  
(27 – 45 kgf, 60 – 100 lbf)

**HINT:**

- "New belt" refers to a belt which has been less than 5 minutes on a running engine.
- "Used belt" refers to a belt which has been used on a running engine for 5 minutes or more.

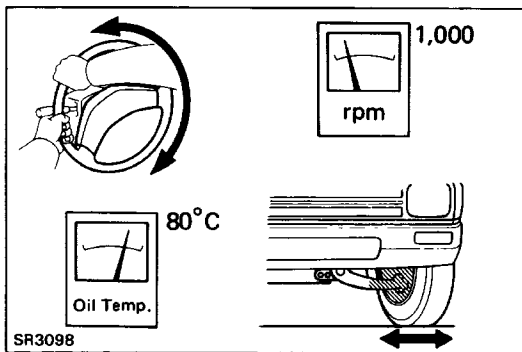
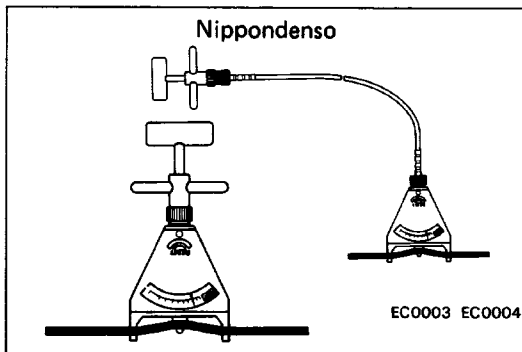

## FLUID LEVEL CHECK

### 1. KEEP VEHICLE LEVEL

### 2. BOOST FLUID TEMPERATURE

With the engine idling at 1,000 rpm or less, turn the steering wheel from lock to lock several times to boost fluid temperature.

**Fluid temperature: 80°C (176°F)**

### 3. CHECK FOR FOAMING OR EMULSIFICATION

**HINT:** Foaming and emulsification indicate either the existence of air in the system or that the fluid level is too low.

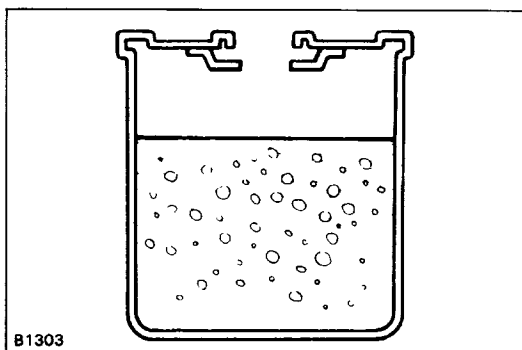

### 4. CHECK FLUID LEVEL IN RESERVOIR

Check the fluid level and add fluid if necessary.

**Fluid: ATF DEXRON®II**

**HINT:** Check that the fluid level is within the **HOT LEVEL** of the dipstick. If the fluid is cold, check that it is within the **COLD LEVEL** of the dipstick.

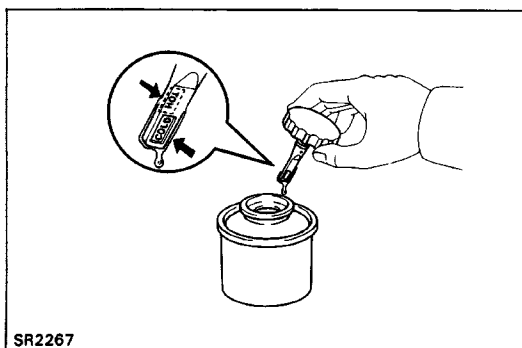

## REPLACEMENT OF POWER STEERING FLUID

1. JACK UP FRONT OF VEHICLE AND SUPPORT IT WITH STANDS

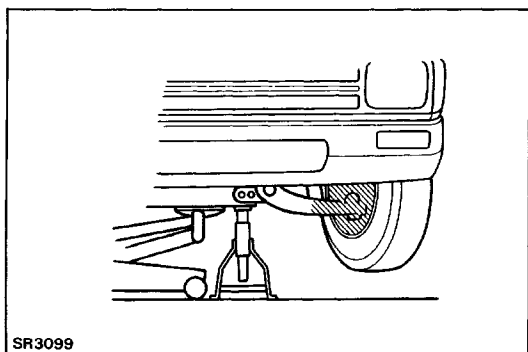

SR3099

2. REMOVE FLUID RETURN HOSE FROM RESERVOIR TANK AND DRAIN FLUID INTO CONTAINER

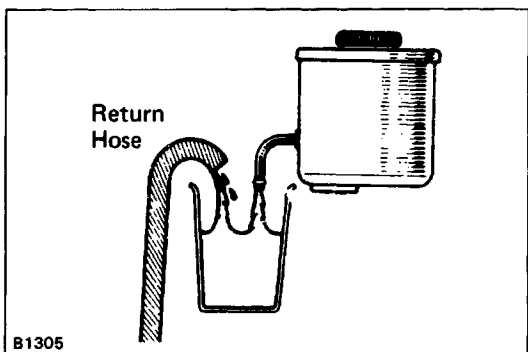

B1305

3. WITH ENGINE IDLING, TURN STEERING WHEEL FROM LOCK TO LOCK WHILE DRAINING FLUID
4. STOP ENGINE

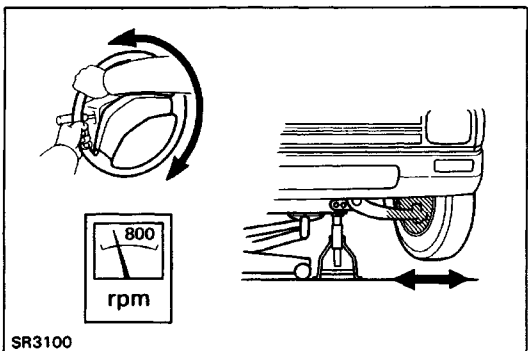

SR3100

5. FILL RESERVOIR TANK WITH FRESH FLUID  
Fluid : ATF DEXRON<sup>®</sup> II

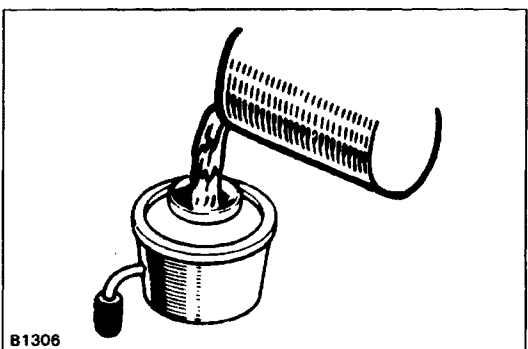

B1306

6. START ENGINE AND RUN IT AT 1,000 RPM

After 1 or 2 seconds, fluid will begin to discharge from the return hose. Stop the engine immediately at this time.  
**NOTICE:** Take care that some fluid remains left in the reservoir tank.

7. REPEAT STEPS 5 AND 6 FOUR OR FIVE TIMES UNTIL THERE IS NO MORE AIR IN FLUID
8. CONNECT RETURN HOSE TO RESERVOIR TANK
9. BLEED POWER STEERING SYSTEM

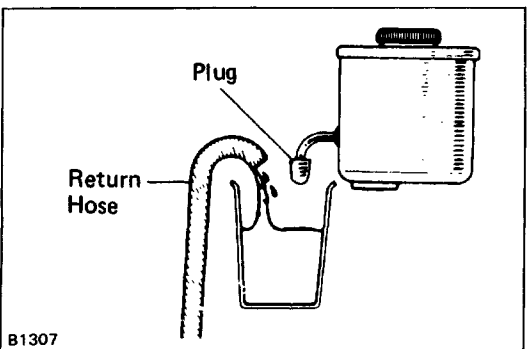

B1307

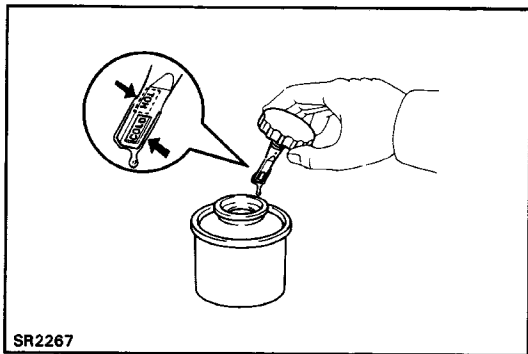

SR2267

## BLEEDING OF POWER STEERING SYSTEM

**NOTICE:** The air bleeding method for vehicles equipped with the rear-wheel anti-lock brake system is different to the former method. For details, see page [BR-95](#).

### 1. CHECK FLUID LEVEL IN RESERVOIR TANK

Check the fluid level and add fluid if necessary.

**Fluid:** ATF DEXRON®II

**HINT:** Check that the fluid level is within the HOT LEVEL of the dipstick. If the fluid is cold, check that it is within the COLD LEVEL of the dipstick.

### 2. START ENGINE AND TURN STEERING WHEEL FROM LOCK TO LOCK THREE OR FOUR TIMES

Run the engine at 1,000 rpm or less.

### 3. STOP ENGINE AND CONNECT VINYL TUBE TO BLEEDER PLUG

### 4. START ENGINE AND TURN STEERING WHEEL FROM LOCK TO LOCK TWO OR THREE TIMES

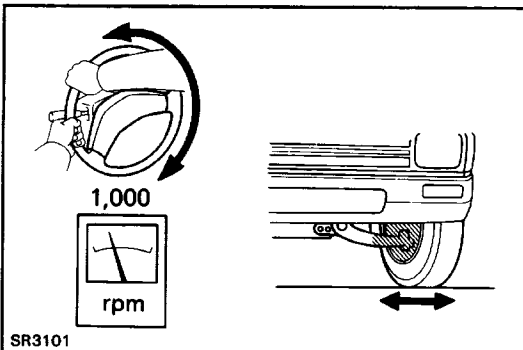

SR3101

### 5. CHECK THAT FLUID IN RESERVOIR IS NOT FOAMY OR CLOUDY AND DOES NOT RISE OVER MAXIMUM WHEN ENGINE IS STOPPED

Measure the fluid level with the engine running. Stop the engine and measure the fluid level.

**Maximum rise:** 5 mm (0.20 in.)

If a problem is found, repeat steps 7 and 8 on page [SR-40](#).

Repair the PS if the problem persists.

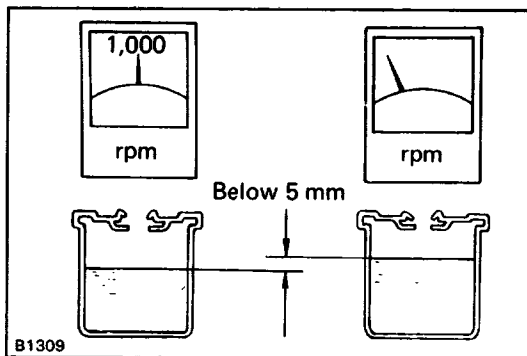

B1309

## OIL PRESSURE CHECK

### 1. CONNECT PRESSURE GAUGE

(a) Disconnect the pressure line from the PS pump.

SST 09631-22020 (RN Series4WD )

(b) Connect the valve side of the pressure gauge to the pressure line, and the gauge side to the PS pump.

(c) Bleed the system. Start the engine and turn the steering wheel from lock to lock two or three times.

(d) Check that the fluid level is correct.

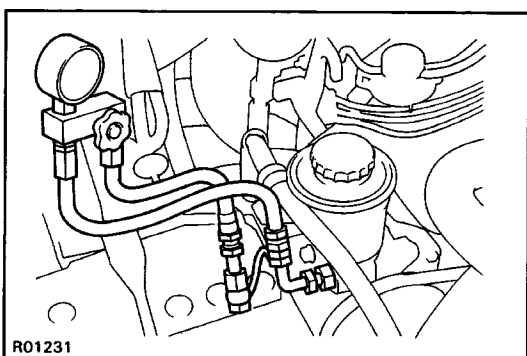

R01231

### 2. CHECK THAT FLUID TEMPERATURE IS AT LEAST 80°C (176°F)

### 3. START ENGINE AND RUN IT AT IDLE

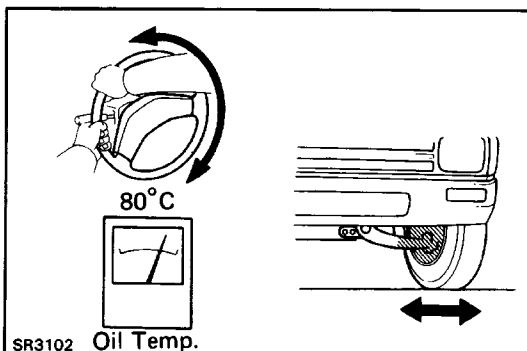

SR3102 Oil Temp.

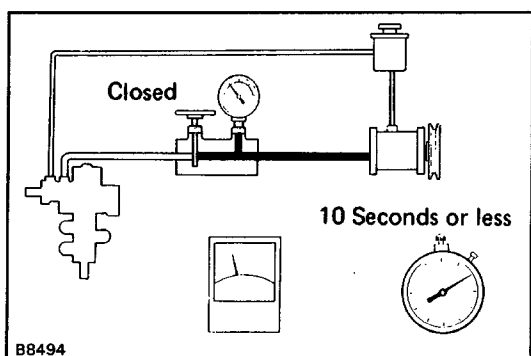

#### 4. CHECK FLUID PRESSURE READING WITH VALVE CLOSED

Close the pressure gauge valve and observe the reading on the gauge.

**Minimum pressure:**

**3VZ Engine 7,845 kPa (80 kg f/cm<sup>2</sup>, 1,138 psi)**

**Ex. 3VZ Engine 7,355 kPa (75 kgf/cm<sup>2</sup>, 1,067 psi)**

**NOTICE:**

- Do not keep the valve closed for more than 10 seconds.
- Do not let the fluid temperature become too high. If pressure is low, repair or replace the PS pump.

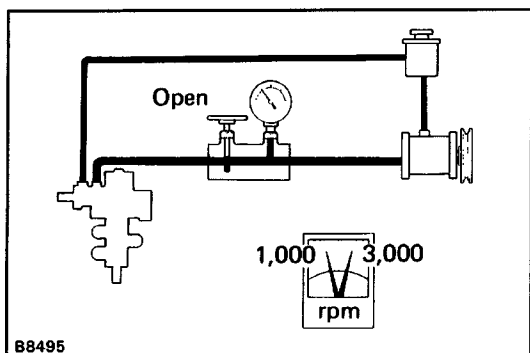

#### 5. OPEN VALVE FULLY

#### 6. CHECK AND RECORD PRESSURE READING AT 1,000 RPM

#### 7. CHECK AND RECORD PRESSURE READING AT 3,000 RPM

Check that there is 490 kPa (5 kgf/cm<sup>2</sup>, 71 psi) or less difference in pressure between the 1,000 rpm and 3,000 rpm checks.

If the difference is excessive, repair or replace the flow control valve of the PS pump.

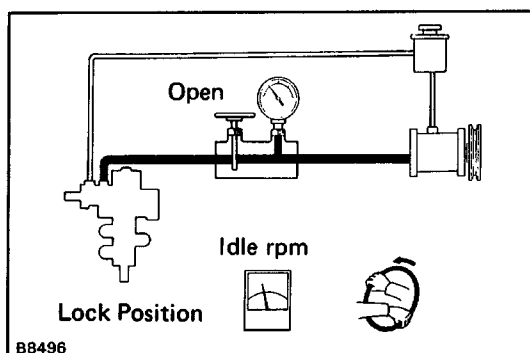

#### 8. CHECK PRESSURE READING WITH STEERING WHEEL TURNED TO FULL LOCK

[Standard type power steering]

Be sure the pressure gauge valve is fully opened and the engine idling.

**Minimum pressure:**

**3VZ Engine 7,845 kPa (80 kg f/cm<sup>2</sup>, 1,138 psi)**

**Ex. 3VZ Engine 7,355 kPa (75 kgf/cm<sup>2</sup>, 1,067 psi)**

If pressure is low, the gear housing has an internal leak and must be repaired or replaced.

[Progressive power steering]

- Turn the steering wheel to full lock position.
- Disconnect the solenoid connector.
- Be sure the pressure gauge valve is fully opened and the engine is running at 1,000 rpm.

**Minimum pressure:**

**3VZ Engine 7,845 kPa (80 kgf/cm<sup>2</sup>, 1,138 psi)**

**Ex. 3VZ Engine 7,355 kPa (75 kgf/cm<sup>2</sup>, 1,067 psi)**

If pressure is low, the gear housing has an internal leak or the solenoid is faulty.

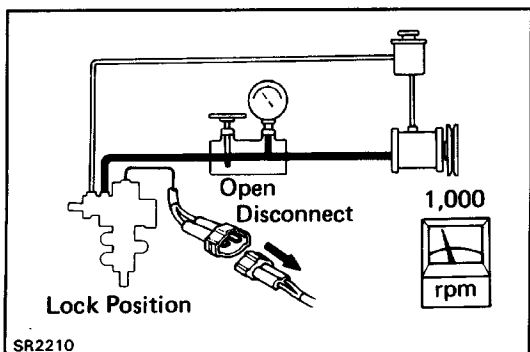

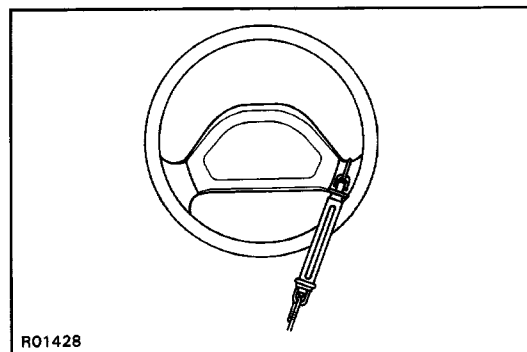
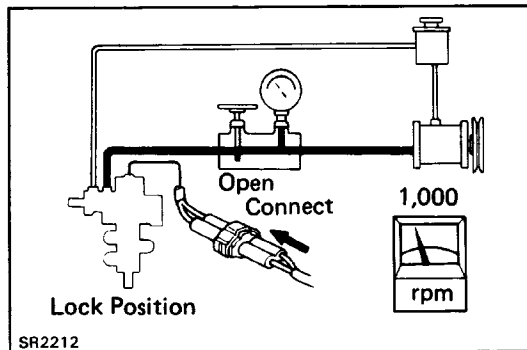
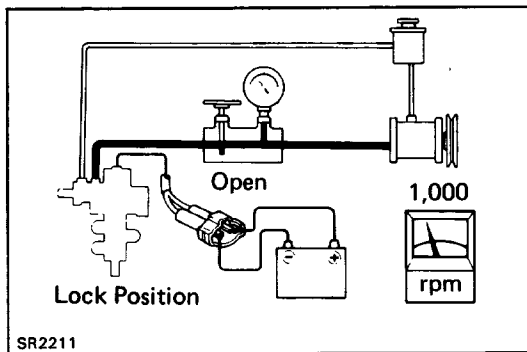

(d) Apply battery positive voltage to the solenoid.

**NOTICE:**

- **Do not apply voltage more than 30 seconds to avoid burning out the solenoid.**
- **If repeating this step, wait until the solenoid cools down enough that it can be touched by hand.**

(e) Check the oil pressure.

**(Reference)**

**Maximum pressure: Approx. 3,923 kPa  
(40 kgf/cm<sup>2</sup>, 569 psi.)**

If pressure is high, check the solenoid.

(f) Connect the solenoid connector and check the oil pressure.

**Minimum pressure:**

**3VZ Engine 7,845 kPa (80 kgf/cm<sup>2</sup>, 1,138 psi)**

**Ex. 3VZ Engine 7,355 kPa (75 kgf/cm<sup>2</sup>, 1,067 psi)**

If pressure is low, the progressive power steering system is faulty.

## 9. MEASURE STEERING EFFORT

### [Standard type power steering]

(a) Center the steering wheel and run the engine at idle.

(b) Using a spring scale, measure the steering effort in both directions.

Maximum steering effort: 39 N (4 kgf, 8.8 lbf)

If steering effort is excessive, repair the power steering unit.

HINT: Be sure to consider the tire type, pressure and contact surface before making your diagnosis.

### [Progressive power steering]

(a) Center the steering wheel and run the engine at idle.

(b) Using a spring scale, measure the steering effort in both directions.

Maximum steering effort: 29 N (3 kgf, 6.6 lbf)

If steering effort is excessive, repair the power steering unit.

(c) Apply battery positive voltage to the solenoid.

**NOTICE:**

- **Do not apply voltage more than 30 seconds to avoid burning out the solenoid.**
- **If repeating this step, wait until the solenoid cools down enough that it can be touched by hand.**

(d) Check that the steering effort is heavier than it was before battery positive voltage was applied to the solenoid.

**(Reference)**

**Maximum steering effort: 118 N (12 kgf, 26 lbf)**

(e) If steering effort is not heavier, check the solenoid.

HINT: Be sure to consider tire type, pressure and contact surface before making your diagnosis.



# Power Steering Pump REMOVAL AND INSTALLATION OF POWER STEERING PUMP

Remove and install the parts as shown.

VZN Series

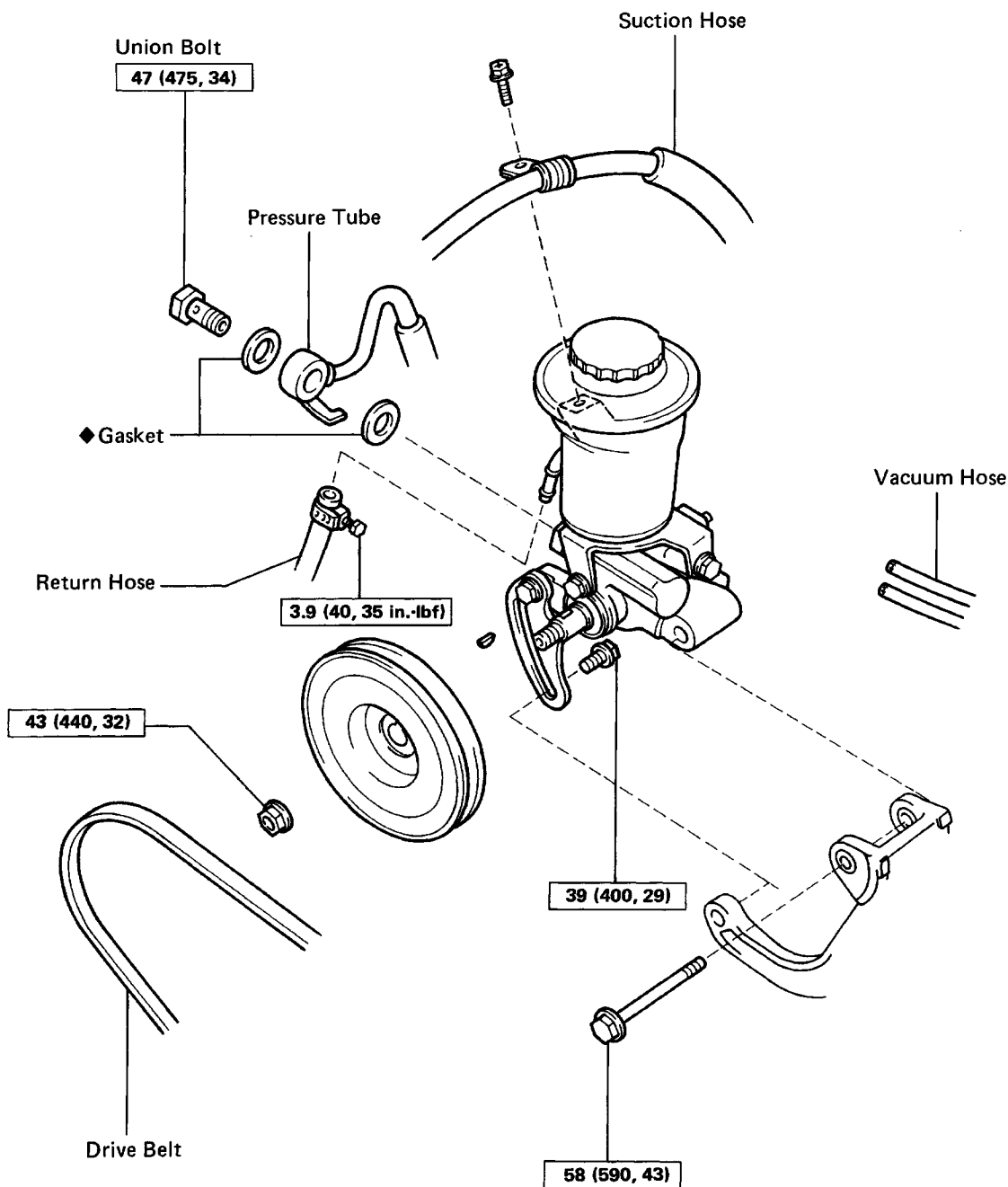

**N·m (kgf·cm, ft·lbf)** : Specified torque

◆ Non-reusable part

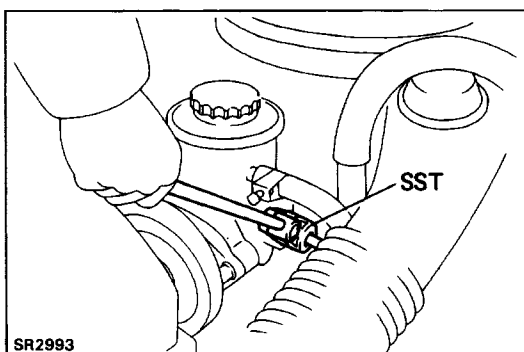
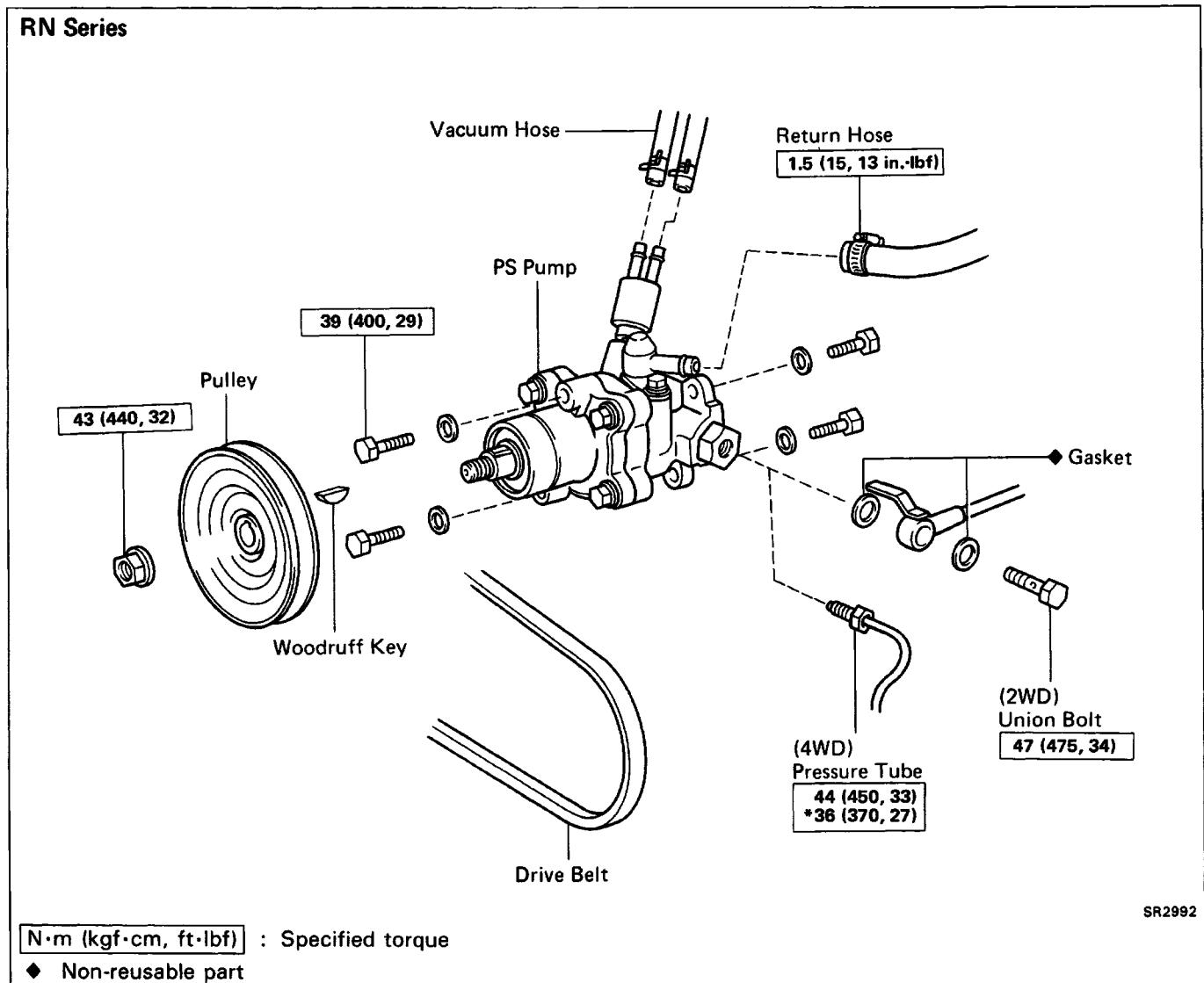

## (MAIN POINTS OF REMOVAL AND INSTALLATION)

### 1. (RN Series/4WD)

#### DISCONNECT AND CONNECT PRESSURE TUBE

Using SST, disconnect and connect the pressure tube from/to the PS pump.

SST 09631-22020

**Torque: 36 N·m (370 kgf·cm, 27 ft·lbf)**

**HINT:** Use a torque wrench with a fulcrum length of 300 mm (11.81 in.).

### 2. LOOSEN PULLEY NUT

Push on the drive belt with your hand to hold the pulley in place and loosen the pulley nut.

### 3. ADJUST DRIVE BELT TENSION AFTER INSTALLING PS PUMP

(See page [SR-40](#))

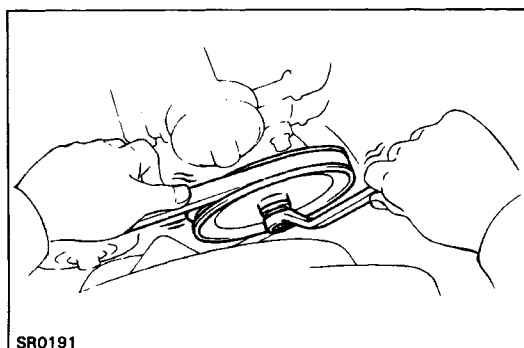

## COMPONENTS (VZN series)

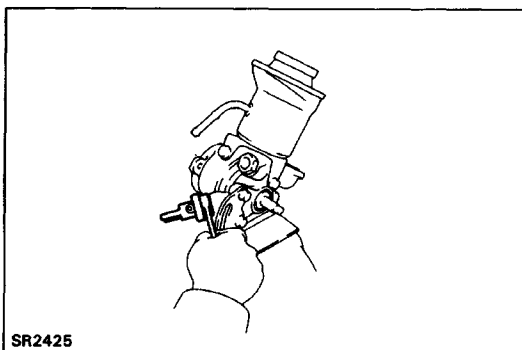
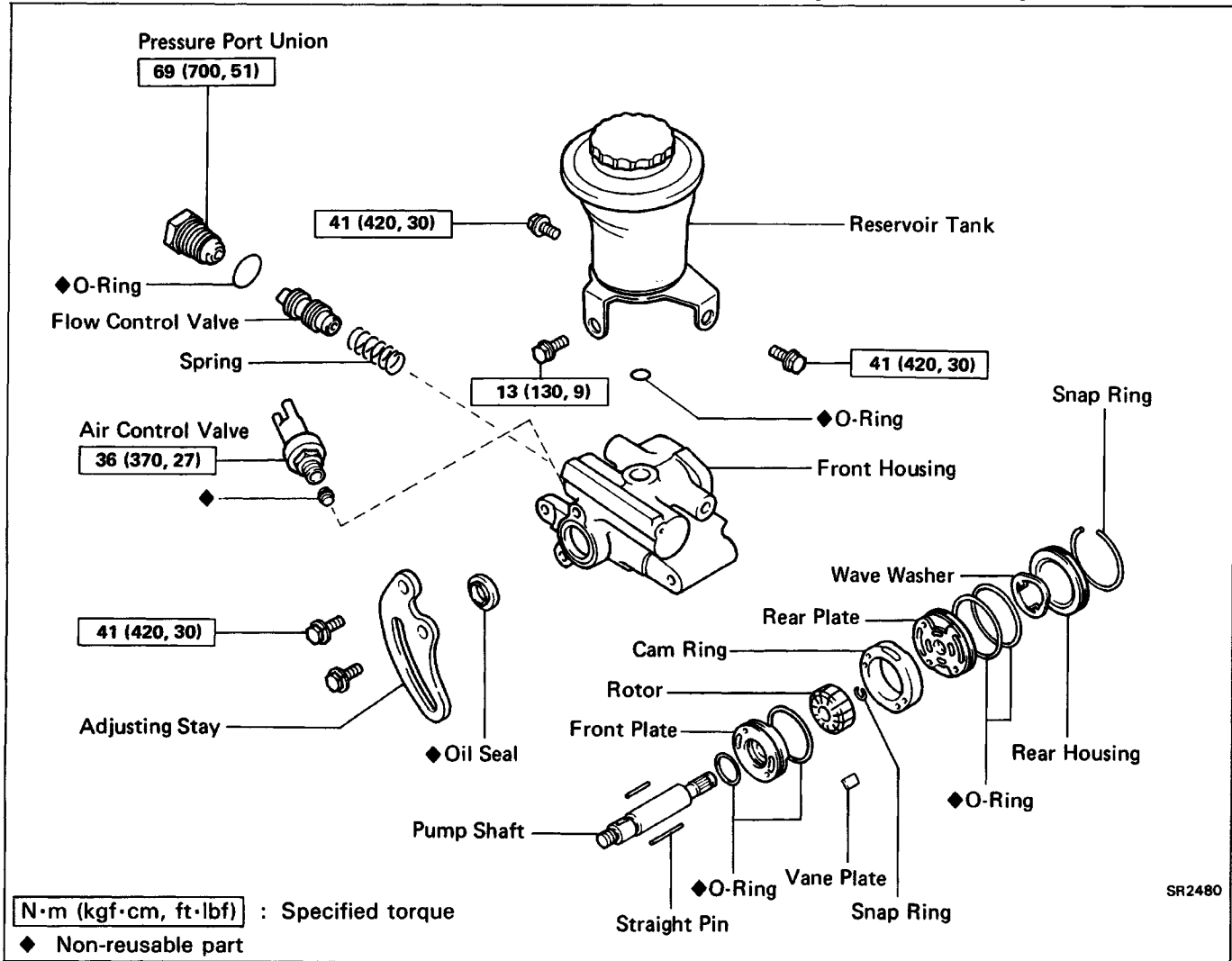

### DISASSEMBLY OF POWER STEERING PUMP

#### 1. CLAMP PS PUMP IN VISE

NOTICE: Do not tighten the vise too tight.

#### 2. REMOVE AIR CONTROL VALVE

- Remove the air control valve.
- Remove the union seat.

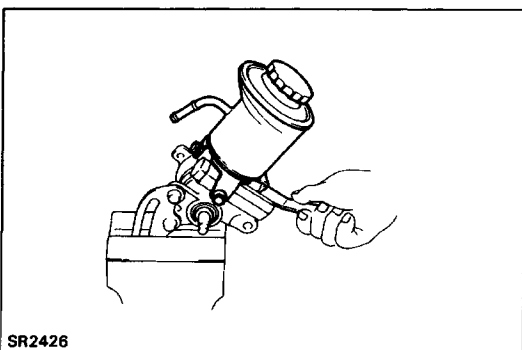

#### 3. REMOVE RESERVOIR TANK

- Remove three bolts and the reservoir tank.
- Remove the O-ring from the reservoir tank.

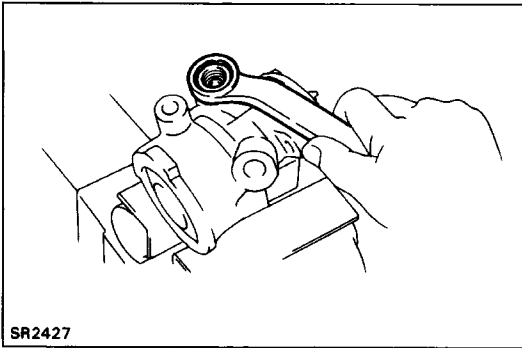

#### 4. REMOVE PRESSURE PORT UNION AND FLOW CONTROL VALVE

- (a) Remove the pressure port union.
- (b) Remove the O-ring from the pressure port union.
- (c) Remove the flow control valve and spring.

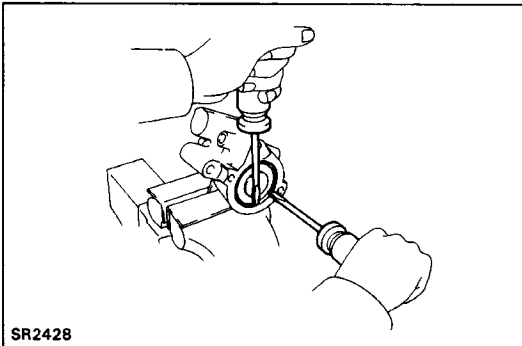

#### 5. REMOVE REAR HOUSING

- (a) Using two screwdrivers, remove the snap ring.

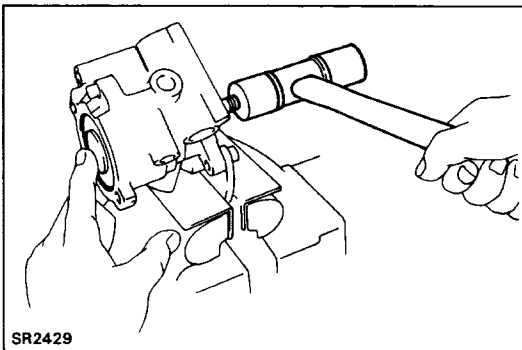

- (b) Using a plastic hammer, tap out the rear housing and wave washer.
- (c) Remove the O-ring from the rear housing.

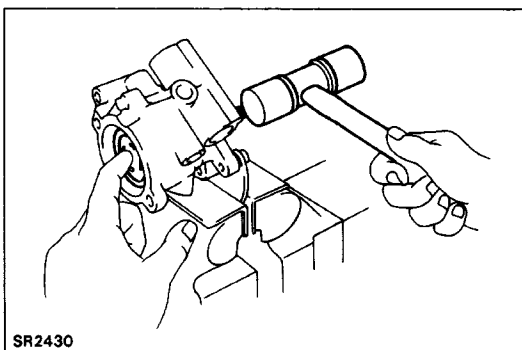

#### 6. REMOVE REAR PLATE

- (a) Using a plastic hammer, tap the shaft end and remove the rear plate.
- (b) Remove the O-ring from the rear plate.

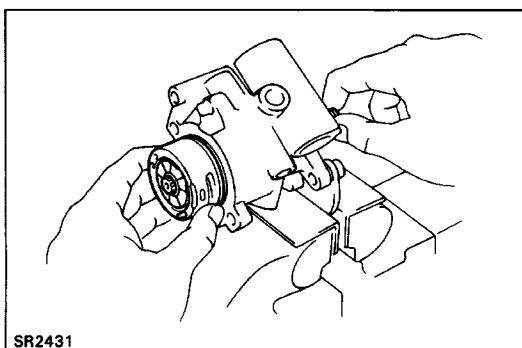

#### 7. REMOVE PUMP SHAFT, CAM RING AND VANE PLATES

- (a) Remove the pump shaft with the cam ring and vane plates from the front housing.
- (b) Remove the cam ring and ten vane plates from the pump shaft.
- (c) Remove the longer straight pin from the front housing.

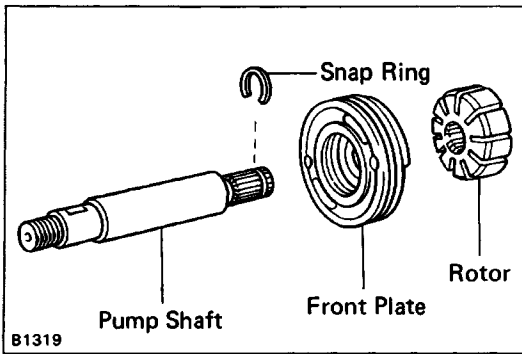

### 8. REMOVE ROTOR AND FRONT PLATE

- (a) Using a screwdriver, remove the snap ring.
- (b) Remove the rotor and front plate from the pump shaft.
- (c) Remove the two O-rings from the front plate.
- (d) Remove the straight pin from the front plate. .

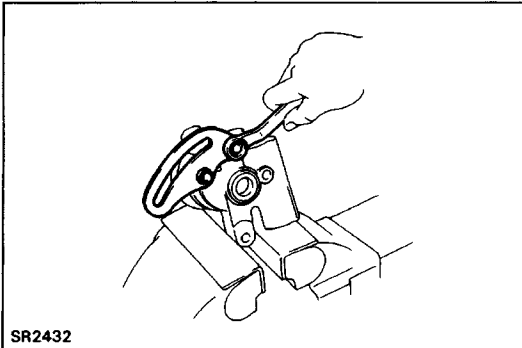

### 9. REMOVE ADJUSTING STAY

Remove the two bolts and adjusting stay.

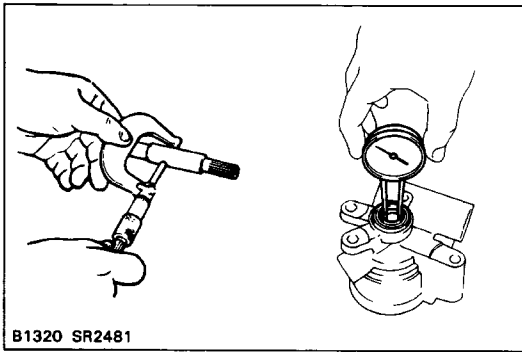

B1320 SR2481

## INSPECTION OF POWER STEERING PUMP

### 1. CHECK OIL CLEARANCE OF SHAFT AND BUSHING

Using a micrometer and calipers, check the oil clearance.

**Standard clearance:** 0.01–0.03 mm

(0.0004 – 0.0012 in.)

**Maximum clearance:** 0.07 mm (0.0028 in.)

If more than maximum, replace the entire PS pump.

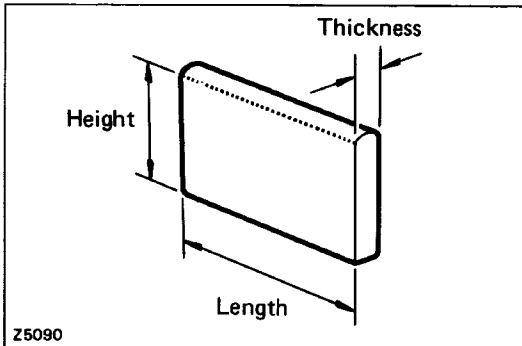

Z5090

### 2. INSPECT ROTOR AND VANE PLATES

(a) Using a micrometer, measure the height, thickness and length of the vane plate.

**Minimum height:** 8.1 mm (0.319 in.)

**Minimum thickness:** 1.797 mm (0.0707 in.)

**Minimum length:** 14.988 mm (0.5901 in.)

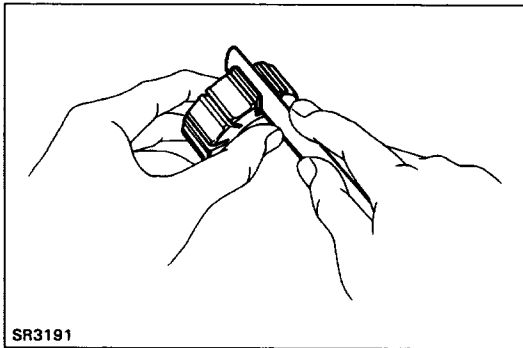

SR3191

(b) Using a feeler gauge, measure the clearance between the rotor groove and vane plate.

**Maximum clearance:** 0.03 mm (0.0012 in.)

If more than maximum, replace the vane plate and/or rotor with one having the same mark stamped on the cam ring.

**Inscribed mark:** 1, 2, 3, 4 or None

**HINT:** There are five vane lengths with the following rotor and cam ring marks:

Rotor and cam ring mark	Vane length	mm (in.)
None	14.996 – 14.998	(0.59039 – 0.59047)
1	14.994 – 14.996	(0.59032 – 0.59039)
2	14.992 – 14.994	(0.59024 – 0.59032)
3	14.990 – 14.992	(0.59016 – 0.59024)
4	14.988 – 14.990	(0.59008 – 0.59016)

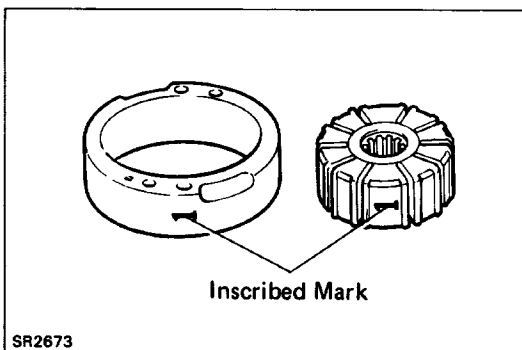

SR2673

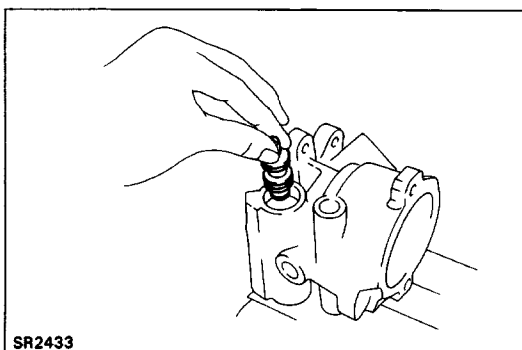

SR2433

### 3. INSPECT FLOW CONTROL VALVE

(a) Coat the valve with power steering fluid and check that it falls smoothly into the valve hole by its own weight.

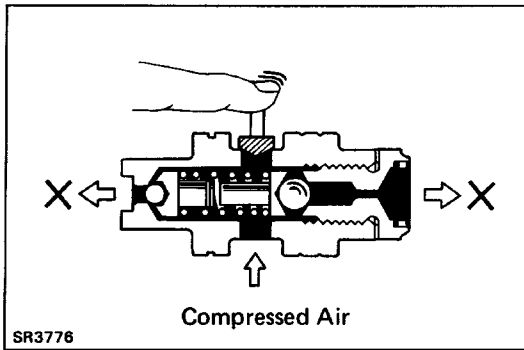

- (b) Check the flow control valve for leakage.

Close one of the holes and apply compressed air [392 – 490 kPa (4 – 5 kgf/cm<sup>2</sup>, 57 – 71 psi)] into the opposite side, and confirm that air does not come out from the end hole.

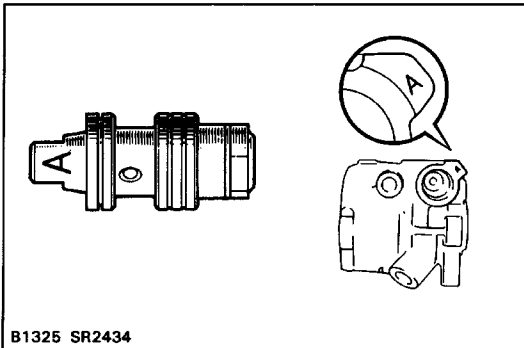

If necessary, replace the valve with one having the same letter as inscribed on the front housing.

**Inscribed mark: A, B, C, D, E or F**

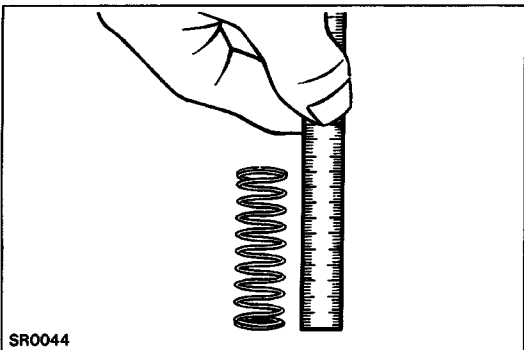

#### 4. INSPECT FLOW CONTROL SPRING

Using a scale, measure the free length of the spring.

**Spring length: 35–37 mm (1.38–1.46 in.)**

If not within specification, replace the spring.

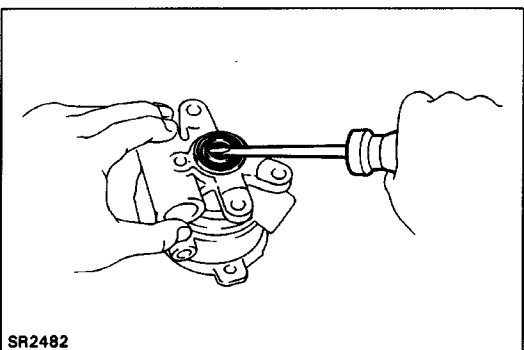

#### 5. IF NECESSARY, REPLACE OIL SEAL

- (a) Using a screwdriver, pry out the oil seal.

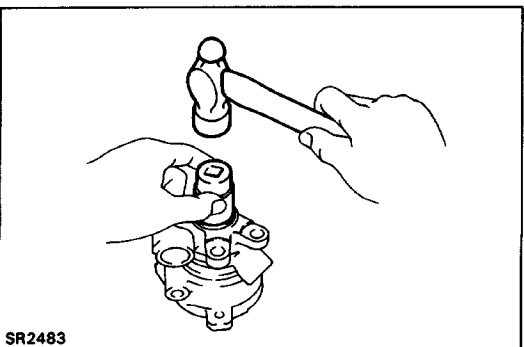

- (b) Using a socket wrench and hammer, drive in a new oil seal.

## ASSEMBLY OF POWER STEERING PUMP

(See page [SR-47](#))

### 1. COAT ALL SLIDING SURFACES WITH POWER STEERING FLUID BEFORE ASSEMBLY

### 2. INSTALL ADJUSTING STAY

Install the adjusting stay and torque the two bolts.  
Torque: 41 N-m (420 kgf-cm, 30 ft-lbf)

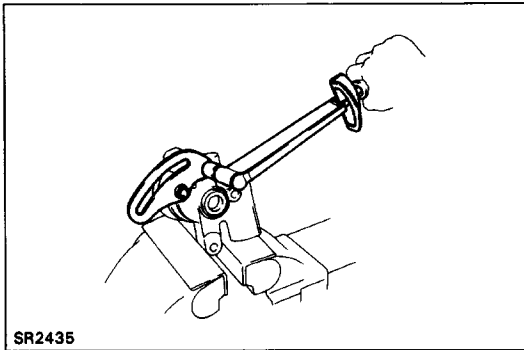

### 3. INSTALL FRONT PLATE AND ROTOR TO PUMP SHAFT

(a) Install the shorter straight pin to the front plate.

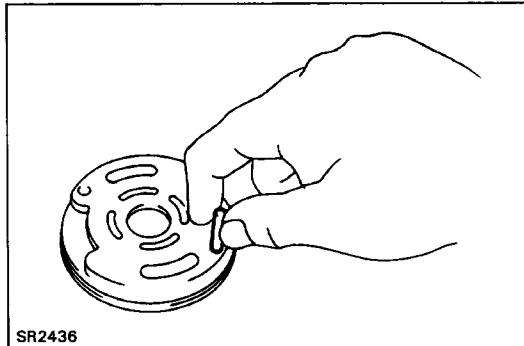

(b) Install two new O-rings to the front plate.

(c) Install the front plate to the pump shaft.

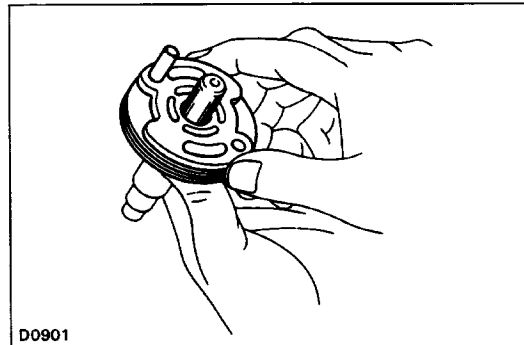

(d) Install the rotor to the pump shaft with the inscribed mark facing outward.

(e) Install the snap ring.

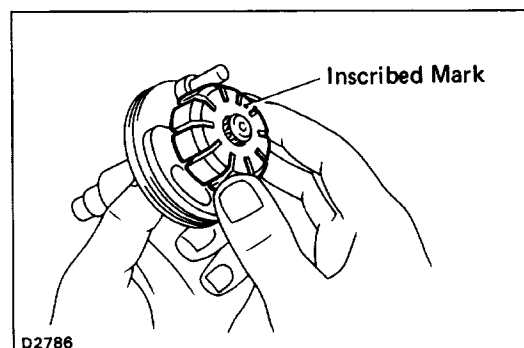

### 4. INSTALL PUMP SHAFT TO FRONT HOUSING

(a) Coat the oil seal lip with MP grease.

(b) Install the longer straight pin to the front housing.

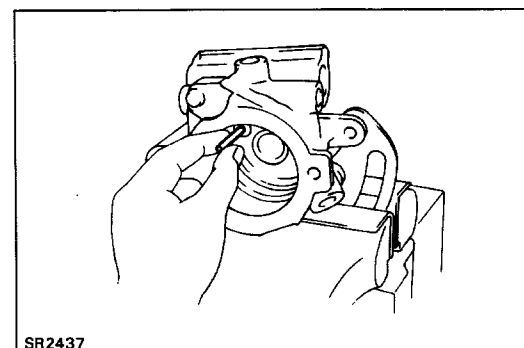



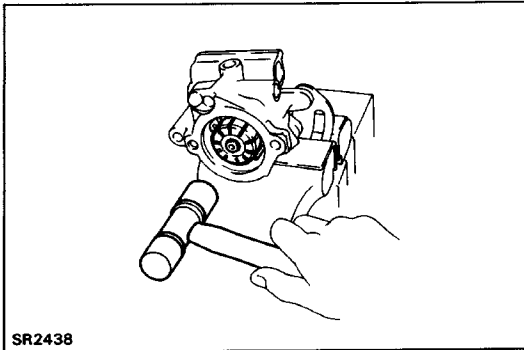

- (c) Align the hole of the front plate and straight pin and tap in the pump shaft with a plastic hammer.  
**NOTICE: Be careful not to damage the oil seal and O-rings.**

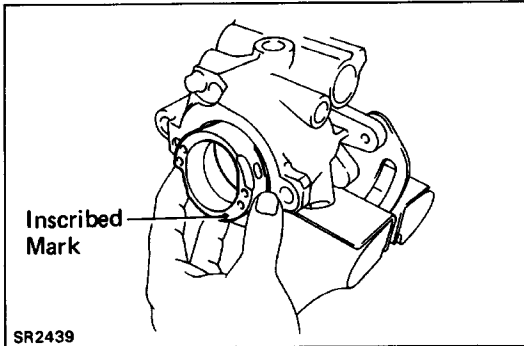

#### 5. INSTALL CAM RING

- Align the oval hole of the cam ring and longer straight pin, and insert the cam ring with the inscribed mark facing outward.

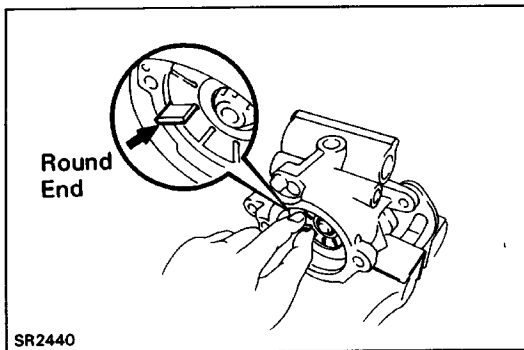

#### 6. INSTALL VANE PLATES

- Install the ten vane plates with the round end facing outward.

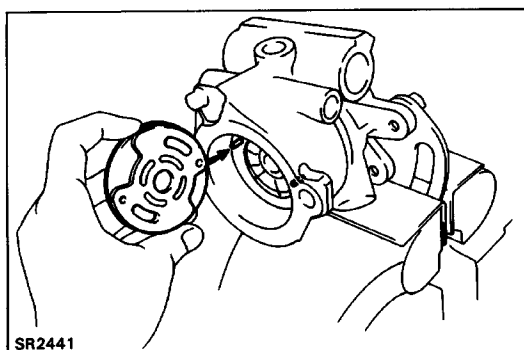

#### 7. INSTALL REAR PLATE

- (a) Install a new O-ring to the rear plate.  
 (b) Align the holes of the rear plate with the pins, and install the plate.

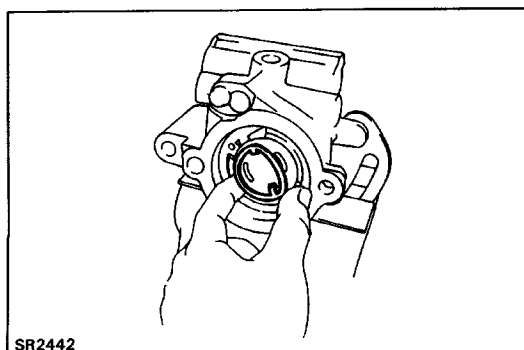

#### 8. INSTALL REAR HOUSING

- (a) Install the wave washer.  
 (b) Install a new O-ring to the rear housing.  
 (c) Using a plastic hammer, tap in the rear housing.

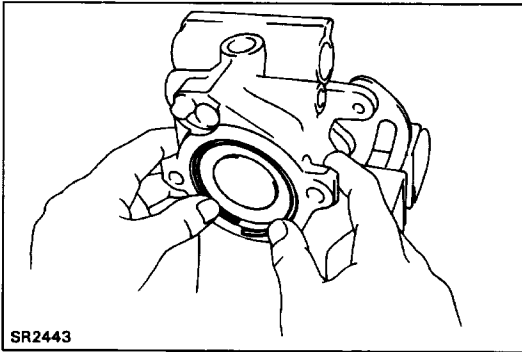

(d) Install the snap ring.

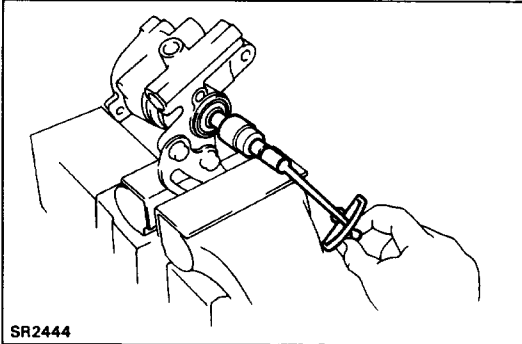

### 9. CHECK PUMP SHAFT PRELOAD

- Check that the shaft rotates smoothly without abnormal noise.
- Temporarily install the pulley nut and check the rotating torque.

**Rotating torque:**

**0.3 N-m (2.8 kgf-cm, 2.4 in.-lbf) or less**

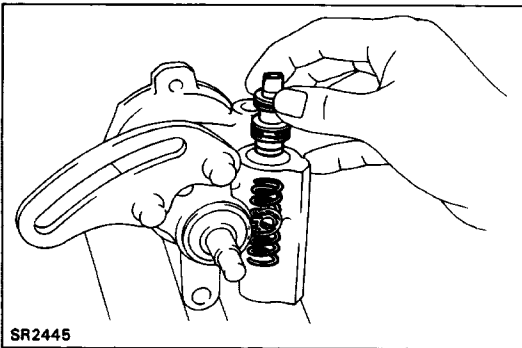

### 10. INSTALL SPRING, FLOW CONTROL VALVE AND PRESSURE PORT UNION

- Install the spring and the valve into the housing.
- Install a new O-ring in the groove of the pressure port union.

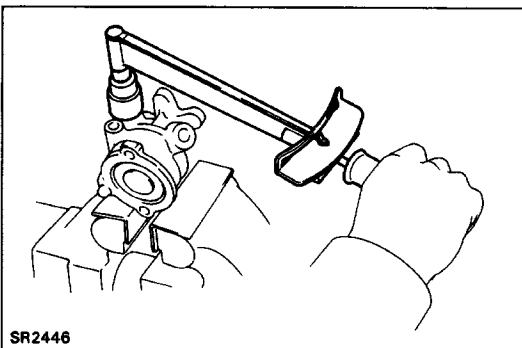

- Install and torque the pressure port union.  
**Torque: 69 N-m (700 kgf-cm, 51 ft-lbf)**

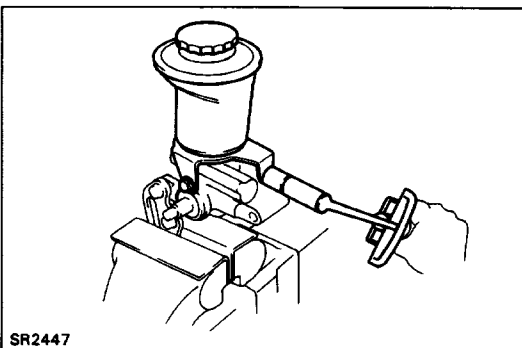

### 11. INSTALL RESERVOIR TANK

- Install a new O-ring to the reservoir tank.
- Install the reservoir tank to the housing and torque the three bolts.

**Torque: 12 mm bolt 13 N-m (130 kgf-cm, 9 ft-lbf)**

**14 mm bolt 41 N-m (420 kgf-cm, 30 ft-lbf)**

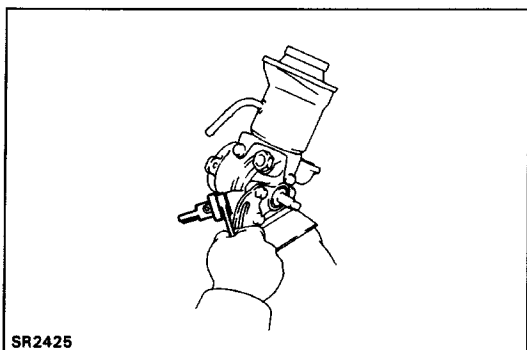

SR2425

**12. INSTALL AIR CONTROL VALVE**

- (a) Install a new union seat to the housing.
- (b) Install and torque the air control valve.

**Torque: 36 N-m (370 kgf-cm, 27 ft-lbf)**

# COMPONENTS (RN series)

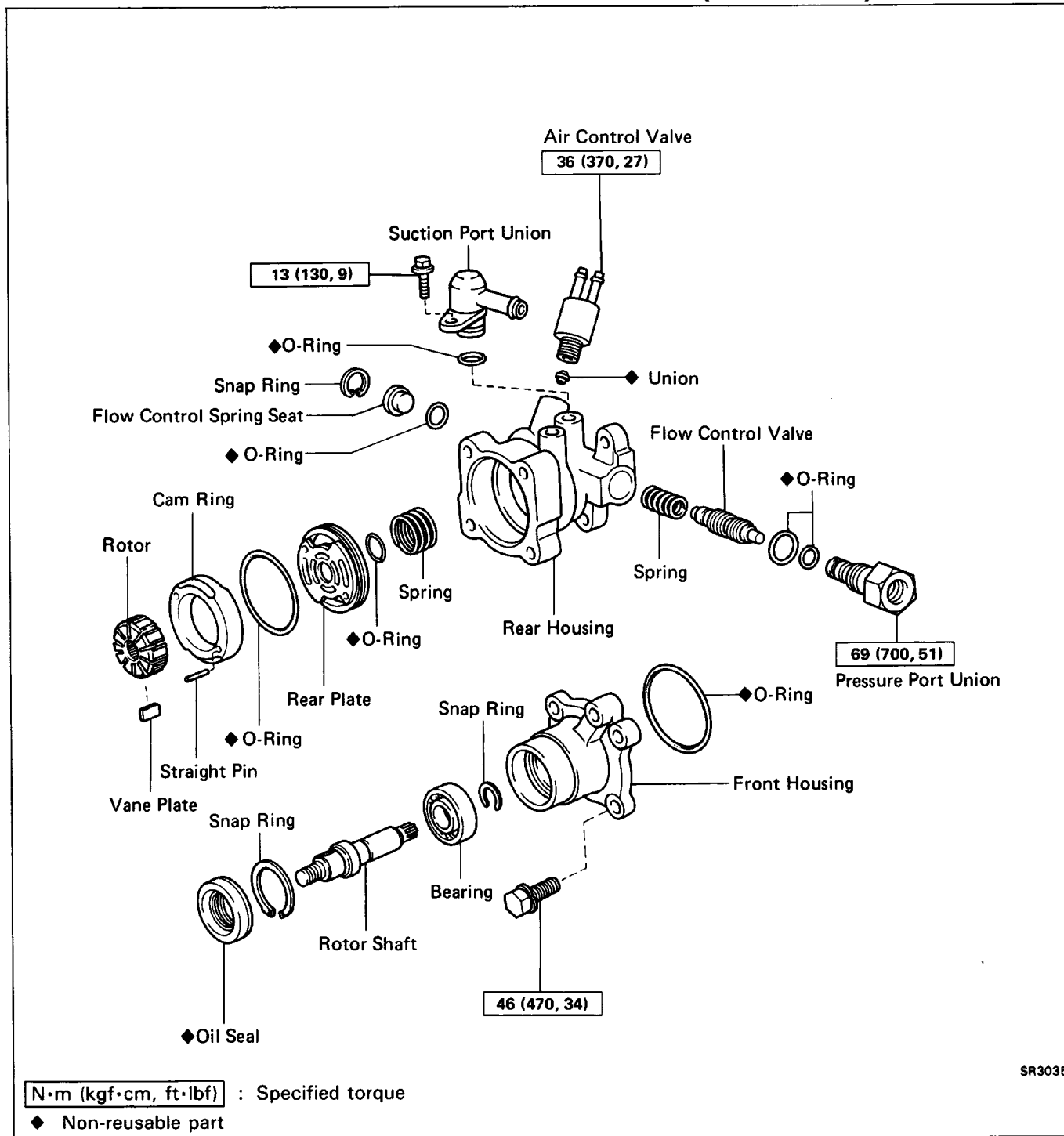

SR3035

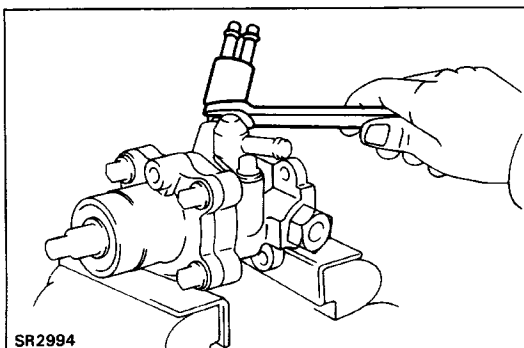

SR2994

## DISASSEMBLY OF POWER STEERING PUMP

### 1. CLAMP PS PUMP IN VISE

NOTICE: Do not tighten the vise too tight.

### 2. REMOVE AIR CONTROL VALVE

- (a) Remove the air control valve.
- (b) Remove the union seat.

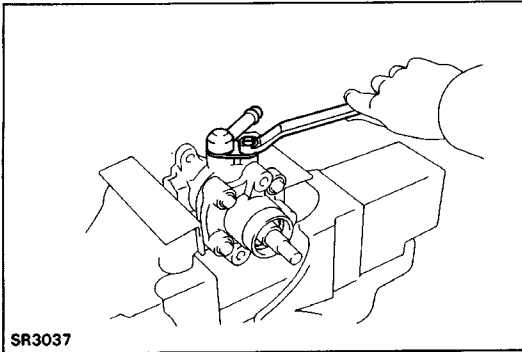

### 3. REMOVE SUCTION PORT UNION

- (a) Remove the bolt and union.
- (b) Remove the O-ring from the union.

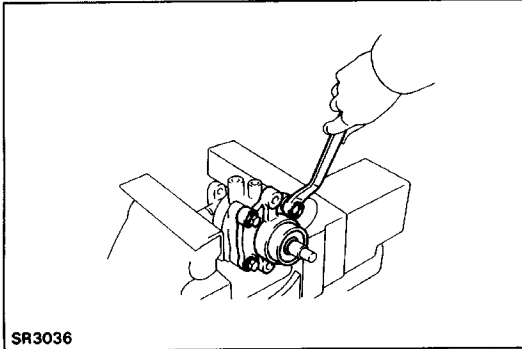

### 4. REMOVE FOUR FRONT HOUSING BOLTS

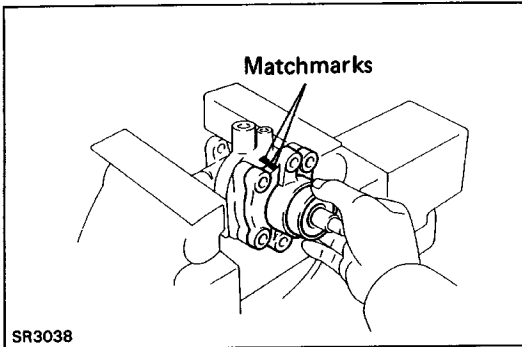

### 5. REMOVE FRONT HOUSING

- (a) Place matchmarks on the front and rear housing.
- (b) Using a plastic hammer, tap off the front housing.

**NOTICE:** Be careful that the vane plates, rotor and cam ring do not fall out.

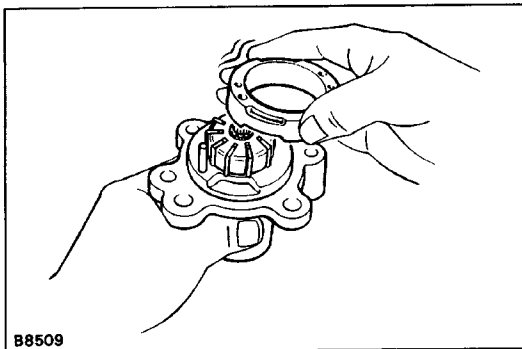

### 6. REMOVE CAM RING, ROTOR AND VANE PLATES

**NOTICE:** Be careful not to scratch the cam ring, rotor or vane plates.

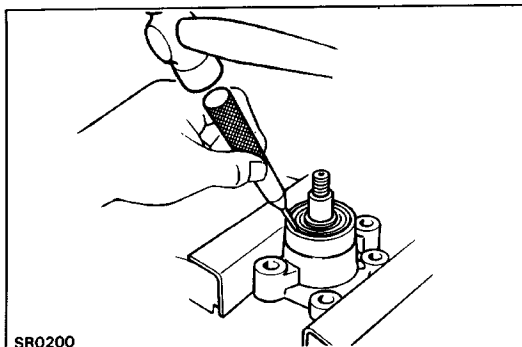

### 7. REMOVE ROTOR SHAFT

- (a) Clamp the front housing in a vise.
  - NOTICE:** Do not tighten the vise too tight.
- (b) Using a chisel and hammer, pry off the oil seal.
- (c) Using snap ring pliers, remove the snap ring.

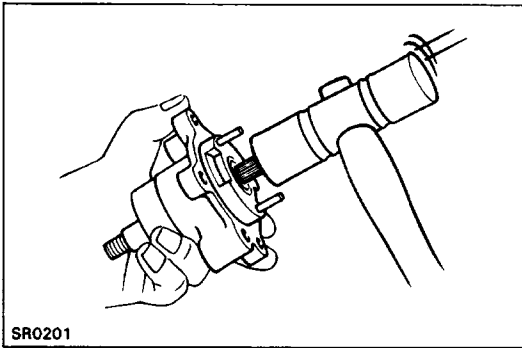

- (d) Using a plastic hammer, lightly tap the rotor shaft out of the front housing.

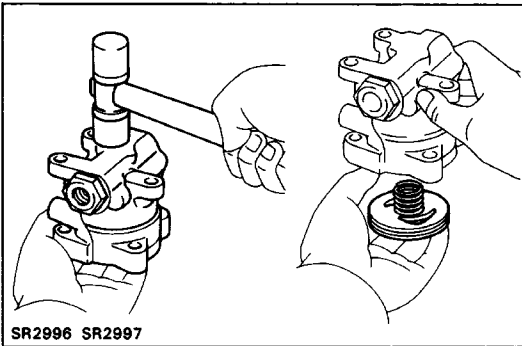

### 8. REMOVE REAR PLATE AND SPRING

Using a plastic hammer, tap the bottom end of the rear housing, and remove the rear plate and spring.

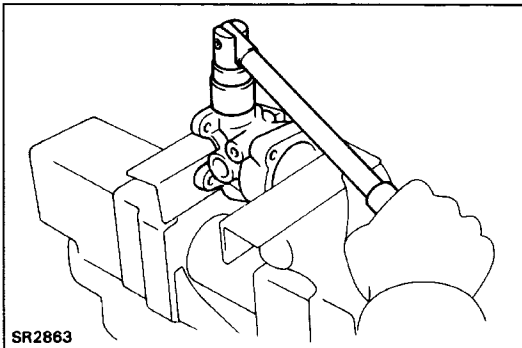

### 9. REMOVE PRESSURE PORT UNION

- (a) Remove the pressure port union.  
 (b) Remove the two O-rings from the union and housing.

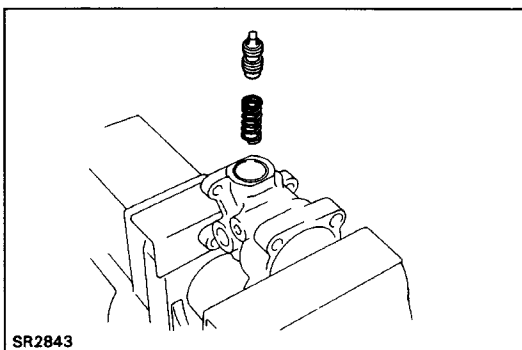

- (c) Remove the flow control valve and spring.  
**NOTICE: Use care not to drop, scratch or nick this valve.**

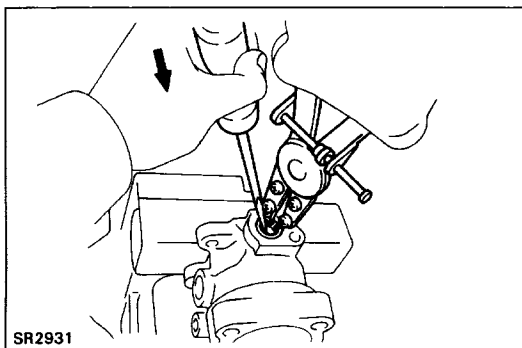

### 10. REMOVE FLOW CONTROL SPRING SEAT

- (a) Temporarily install a bolt to the spring seat.  
 (b) Push the bolt and remove the snap ring with snap ring pliers.

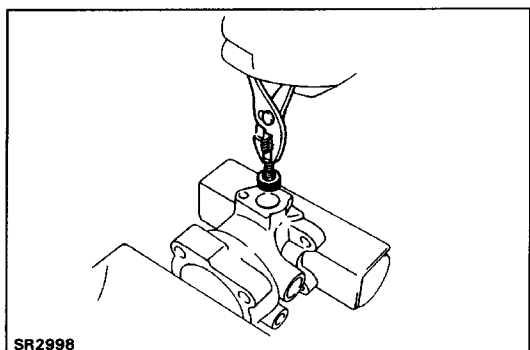

- (c) Pull out the bolt and remove the spring seat.  
 (d) Remove the O-ring from the spring seat.

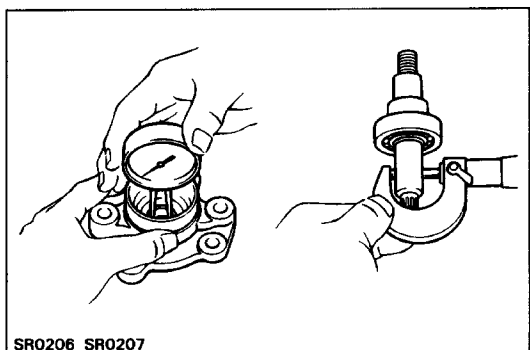

## INSPECTION OF POWER STEERING PUMP

### 1. INSPECT BUSHING AND MEASURE BUSHING OIL CLEARANCE

- (a) Check the bushing for wear or damage. The bushing cannot be replaced separately.  
 If wear or damage is found, replace entire housing.  
 (b) Check the oil clearance between the bushing and rotor shaft.

**Maximum oil clearance: 0.07 mm (0.0028 in.)**

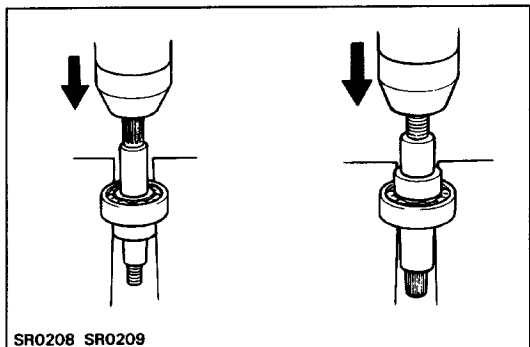

### 2. IF NECESSARY, REPLACE ROTOR SHAFT BEARING

- (a) Using snap ring pliers, remove the snap ring.  
 (b) Using a press, press out the bearing.  
 (c) Using a press, press in a new bearing.  
 (d) Using snap ring pliers, install the snap ring.

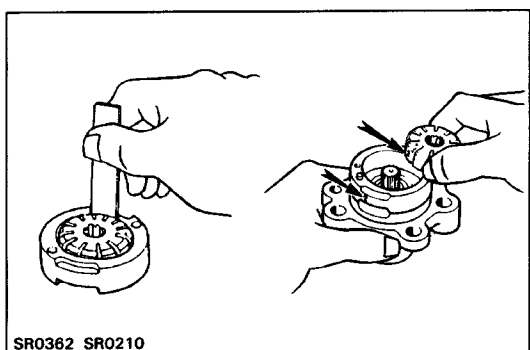

### 3. INSPECT ROTOR AND CAM RING

Measure the cam ring thickness. Check that the difference between the rotor and cam ring measurement is less than maximum.

**Maximum difference: 0.06 mm (0.0024 in.)**

If the difference is excessive, replace the cam ring with one having the same letter as on the rotor.

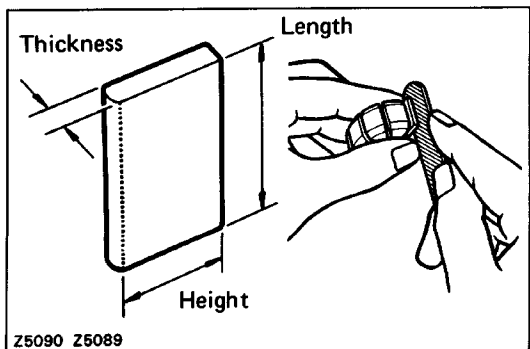

### 4. INSPECT AND MEASURE VANE PLATES

- (a) Check the vane plates for wear or scratches.  
 (b) Measure the length, height and thickness of the vane plates.

**Minimum length: 14.988 mm (0.5901 in.)**

**Minimum height: 8.1 mm (0.319 in.)**

**Minimum thickness: 1.797 mm (0.0707 in.)**

- (c) Measure the clearance between the vane plate and rotor groove.

**Maximum clearance: 0.03 mm (0.0012 in.)**

HINT: There are five vane lengths with the following rotor and cam ring numbers:

Rotor and cam ring number	Vane length mm (in.)
None	14.996 – 14.998 (0.59039 – 0.59047)
1	14.994 – 14.996 (0.59032 – 0.59039)
2	14.992 – 14.994 (0.59024 – 0.59032)
3	14.990 – 14.992 (0.59016 – 0.59024)
4	14.988 – 14.990 (0.59008 – 0.59016)

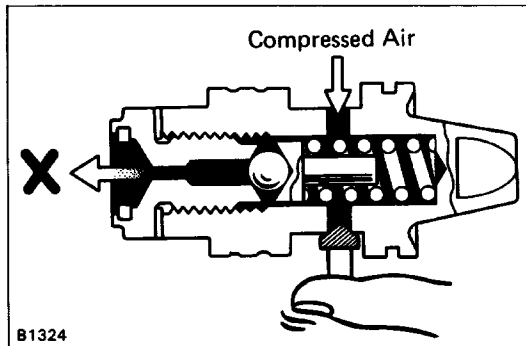

### 5. INSPECT FLOW CONTROL VALVE

- Check the flow control valve for wear or damage.
- Apply fluid to the valve and check that it falls smoothly into the valve hole by its own weight.
- Check the flow control valve for leakage. Close one of the holes and apply compressed air [392 – 490 kPa (4 – 5 kgf/cm<sup>2</sup>, 57 – 71 psi)] into the opposite side, and confirm that air does not come out from the end hole.

If necessary, replace the valve with one having the same letter as inscribed on the rear housing.

### 6. INSPECT FLOW CONTROL VALVE SPRING

Check that the spring is within specification.

**Spring length: 35 – 37 mm (1.38 – 1.46 in.)**

If the spring is not within specification, replace it.

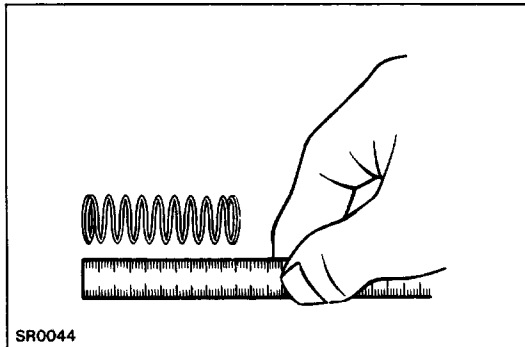



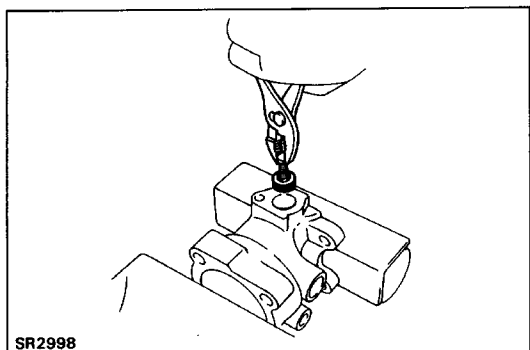

SR2998

## ASSEMBLY OF POWER STEERING PUMP

(See page [SR-56](#))

### 1. INSTALL FLOW CONTROL SPRING SEAT

- (a) Install a new O-ring to the spring seat.
- (b) Install the spring seat to the housing.

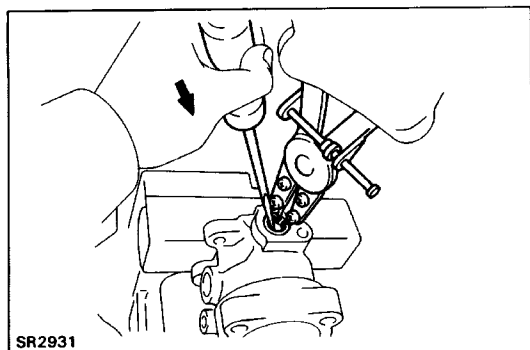

SR2931

- (e) Using snap ring pliers, install the snap ring.

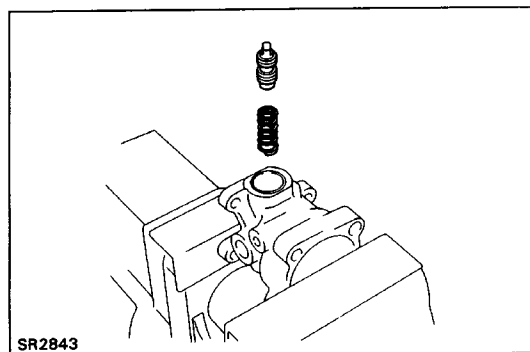

SR2843

### 2. INSTALL FLOW CONTROL VALVE AND SPRING

- (a) Install new O-ring to the housing.
- (b) Install the spring and valve to the housing.

HINT: Be sure the letter inscribed on the flow control valve matches the letter stamped on the rear of the pump body.

Inscribed mark: A, B, C, D, E or F

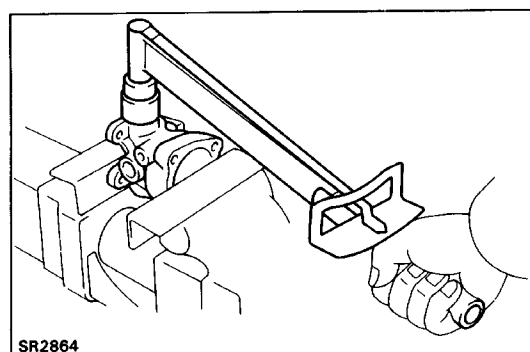

SR2864

### 3. INSTALL PRESSURE PORT UNION

- (a) Install a new O-ring to the pressure port union.
- (b) Install and torque the union.

Torque: 69 N-m (700 kgf-cm, 51 ft-lbf)

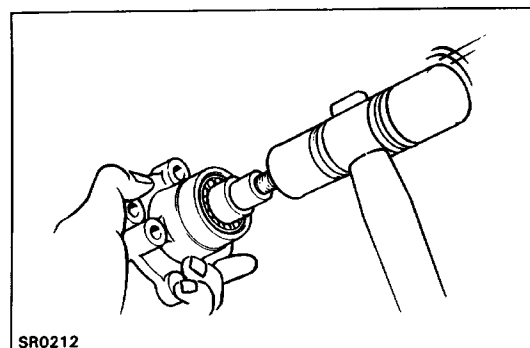

SR0212

### 4. INSTALL ROTOR SHAFT TO FRONT HOUSING

Install the rotor shaft into the front housing by tapping it in with a plastic hammer.

### 5. INSTALL SNAP RING

Using snap ring pliers, install the snap ring to the front housing.

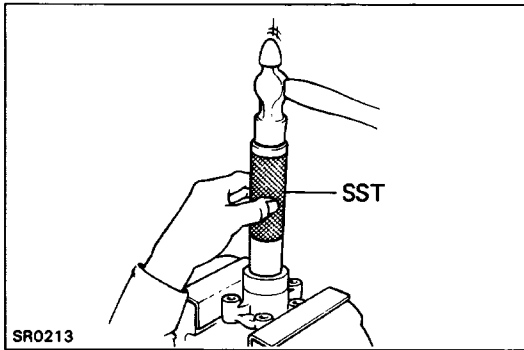

## 6. INSTALL OIL SEAL

- (a) Apply a light coat of MP grease to a new oil seal lip.
- (b) Using SST and a hammer, install the oil seal.  
SST 09608-30012 (09608-04030)

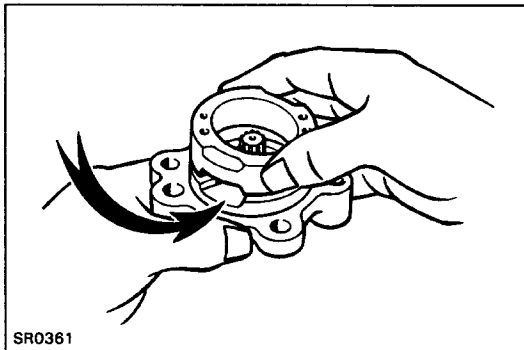

## 7. INSTALL NEW O-RING

## 8. INSTALL CAM RING

Align the fluid passages of the cam ring and front housing, and install the cam ring.

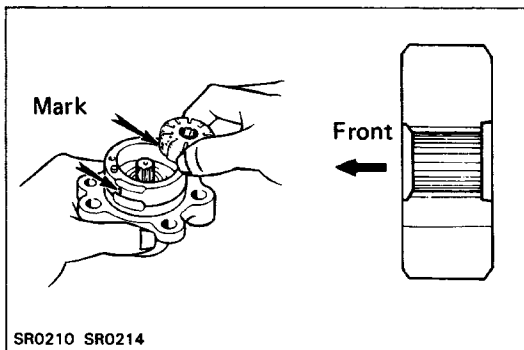

## 9. INSTALL ROTOR

Install the rotor with the chamfered end facing toward the front.

HINT: Be sure the letters inscribed on the cam ring and rotor match.

Inscribed mark: 1, 2, 3, 4, or None

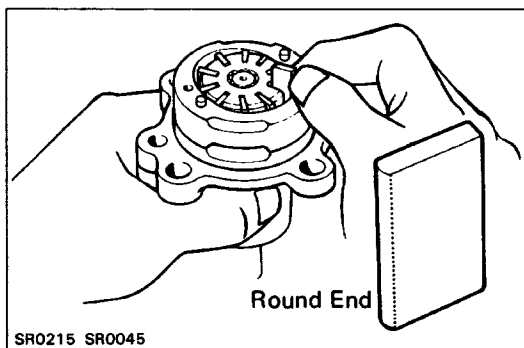

## 10. INSTALL VANE PLATES

Install the vane plates with the round end facing outward.

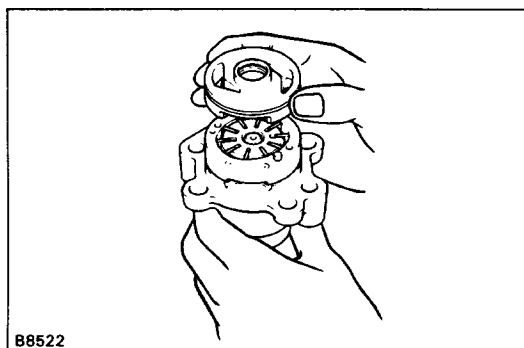

## 11. INSTALL REAR PLATE AND SPRING

- (a) Align the fluid passages of the rear plate and cam ring, and install the rear plate.

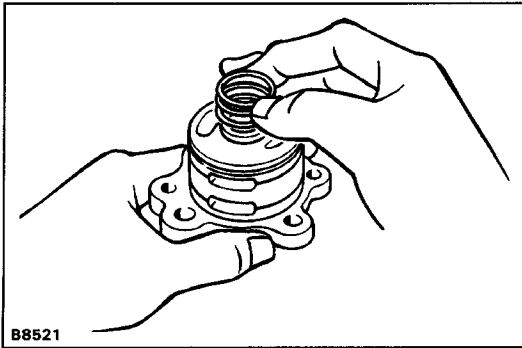

- (b) Place the spring on the rear plate.

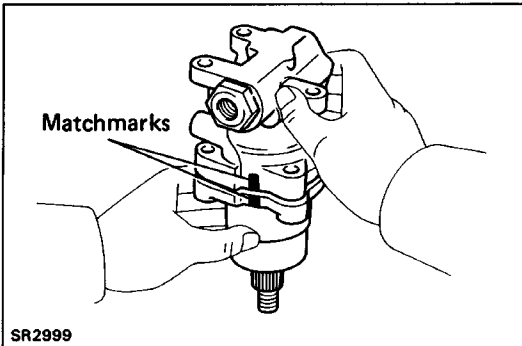

## 12. INSTALL REAR HOUSING

- (a) Align the matchmarks on the front and rear housing and assemble them.  
 (b) Tighten the front and rear housing mount bolts by hand.

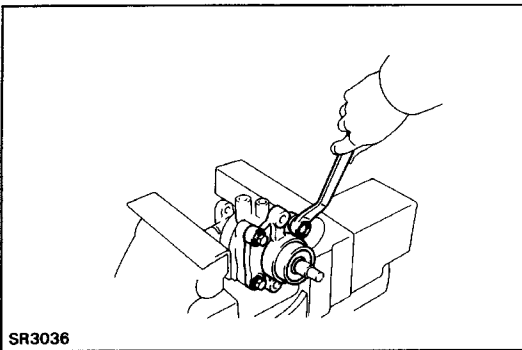

## 13. TIGHTEN FOUR HOUSING BOLTS

- (a) Clamp the rear housing in a vise.  
**NOTICE: Do not tighten the vise too tight.**  
 (b) Tighten the four housing bolts evenly in 3 or 4 passes.  
**Torque: 46 N-m (470 kgf-cm, 34 ft-lbf)**

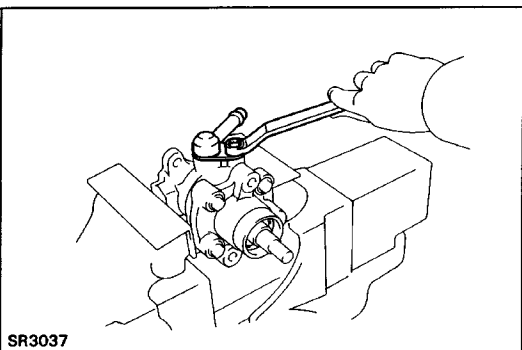

## 14. INSTALL SUCTION PORT UNION

- Install and tighten the union with a new O-ring.  
**Torque: 13 N-m (130 kgf-cm, 9 ft-lbf)**

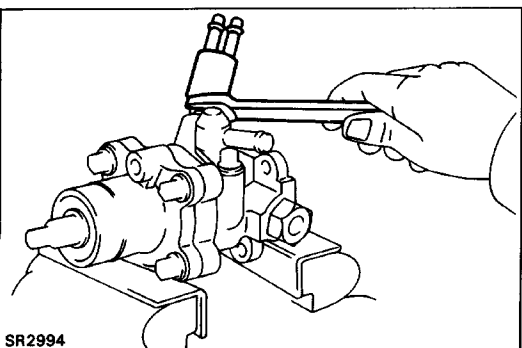

## 15. INSTALL AIR CONTROL VALVE

- Install a \*new union seat and the valve.

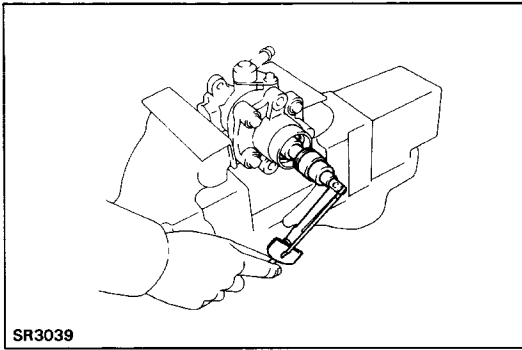
**16. CHECK ROTOR SHAFT ROTATION CONDITION**

- (a) Check that the rotor shaft rotates smoothly without abnormal noise.
- (b) Provisionally install the pulley nut and check the rotation torque.

**Rotation torque:**

**0.3 N-m (2.8 kgf-cm, 2.4 in.-lbf ) or less**

## Gear Housing (2WD)

### REMOVAL AND INSTALLATION OF GEAR HOUSING

Remove and install the parts as shown.

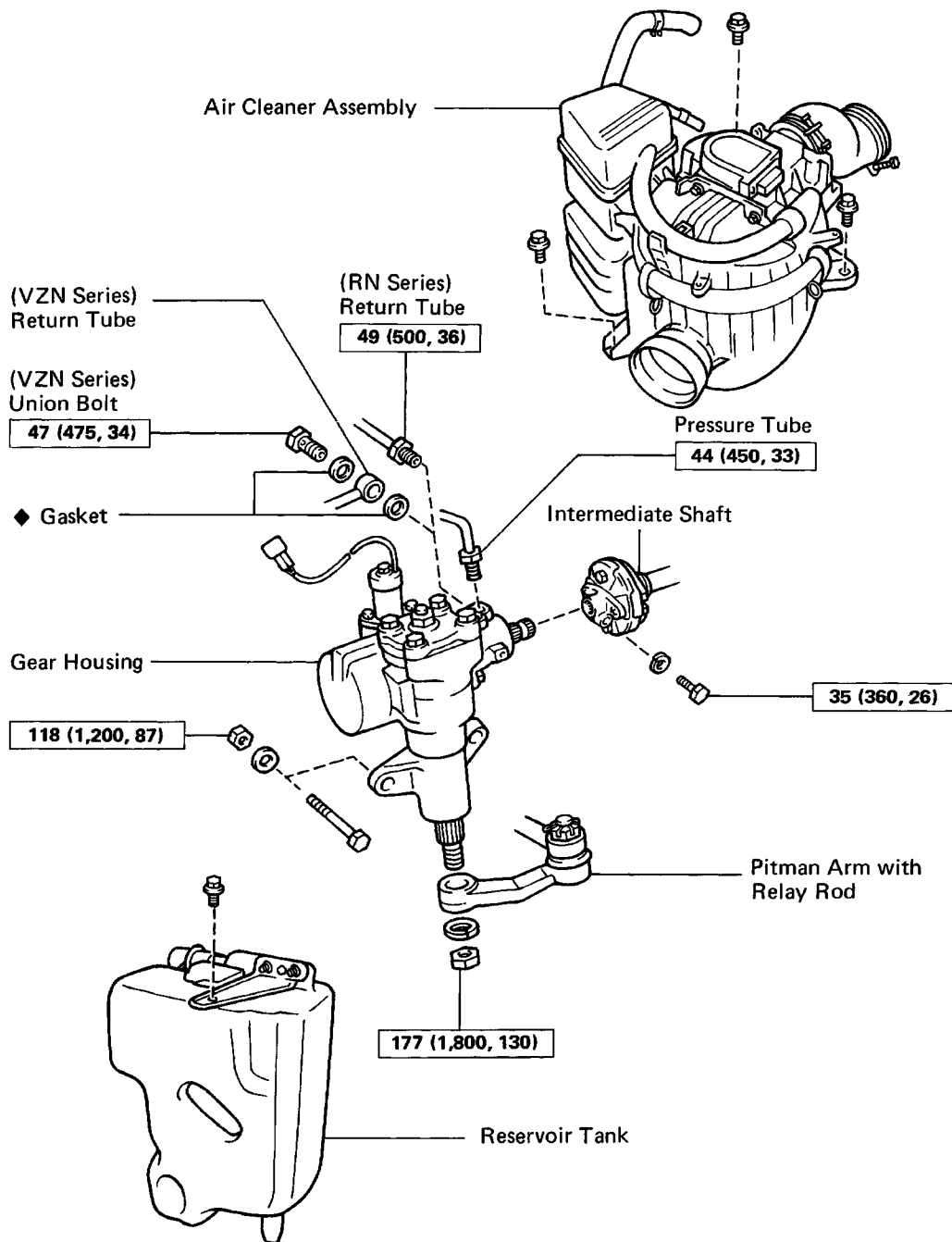

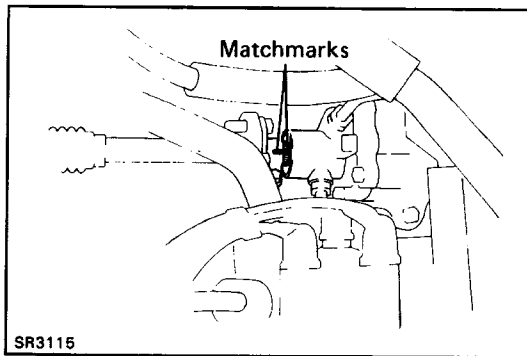

## (MAIN POINTS OF REMOVAL AND INSTALLATION)

### 1. DISCONNECT UNIVERSAL JOINT

- (a) Loosen the column side set bolt.
- (b) Remove the gear side set bolt.
- (c) Place matchmarks on the flexible coupling and worm shaft.
- (d) Slide the shaft rearward to disconnect the shaft from the worm shaft.

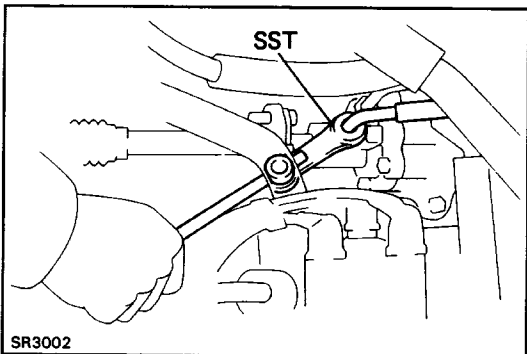

### 2. DISCONNECT PRESSURE AND RETURN TUBES FROM GEAR HOUSING

- Using SST, disconnect the pressure and return tubes from the gear housing.  
SST 09631-22020

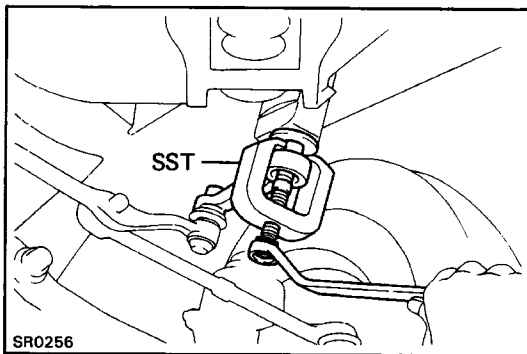

### 3. DISCONNECT AND CONNECT PITMAN ARM

- (a) Using SST, disconnect the pitman arm from the gear housing.  
SST 09610-55012

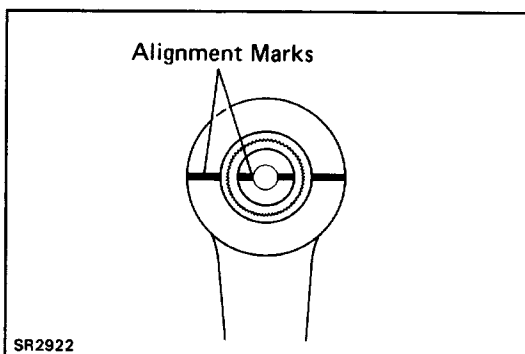

- (b) When connecting, align alignment marks on the pitman arm and the cross shaft, and install the spring washer and nut.

**Torque: 177 N-m (1,800 kgf-cm, 130 ft-lbf)**

# COMPONENTS

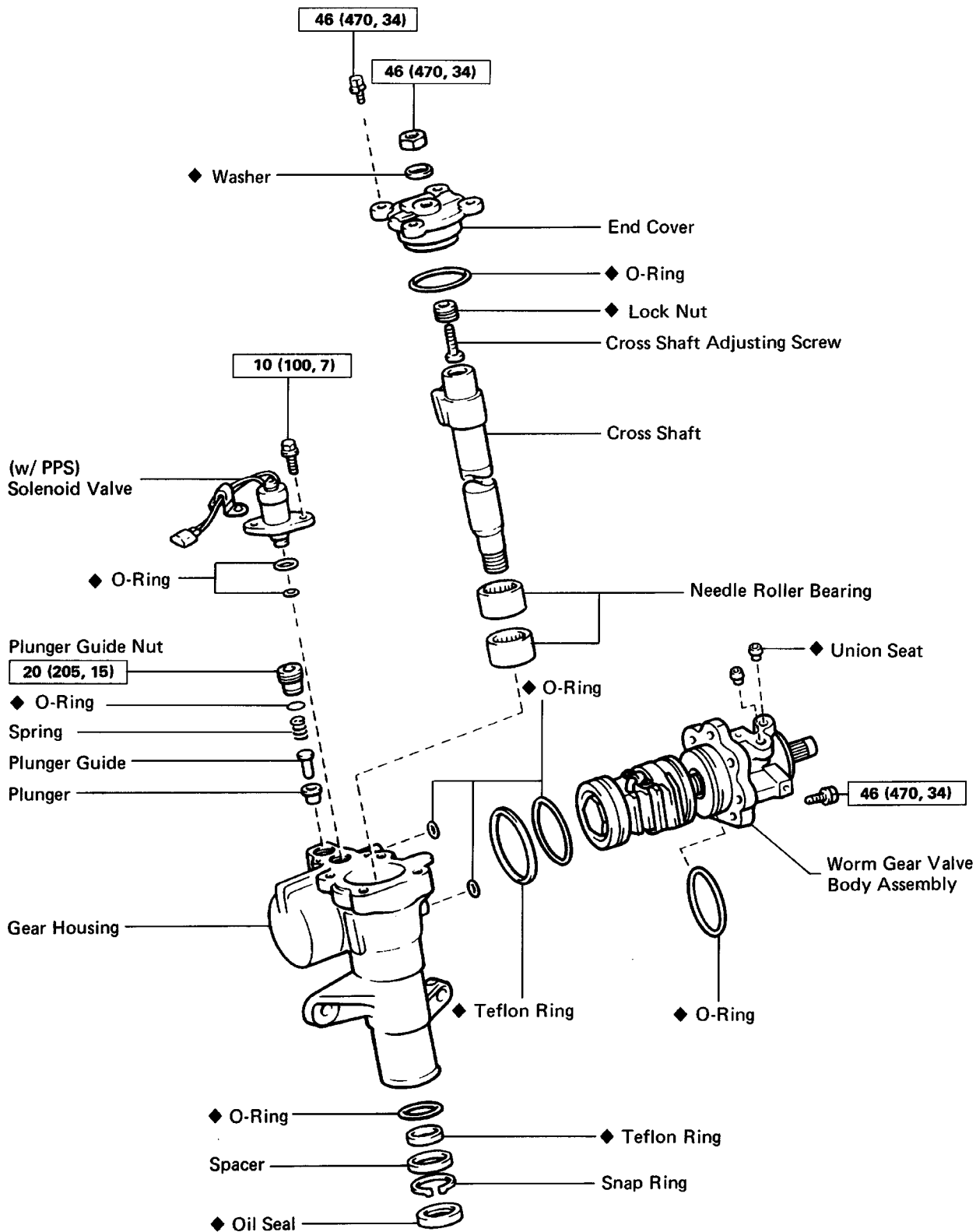

N·m (kgf·cm, ft·lbf) : Specified torque

◆ Non-reusable part

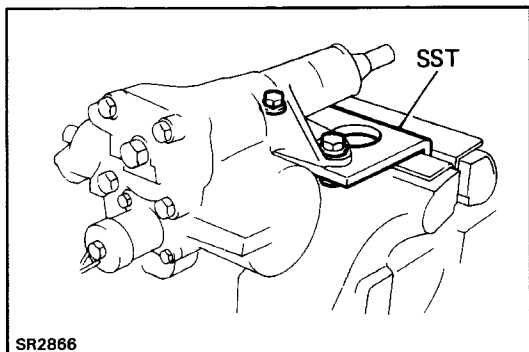

## DISASSEMBLY OF GEAR HOUSING

(See page [SR-67](#))

### 1. MOUNT HOUSING ON STAND

Mount the gear housing on SST and clamp SST in a vise.  
SST 09630-00012 (09631-00140)

### 2. (w/PPS)

#### REMOVE SOLENOID VALVE

- Remove the two bolts and solenoid valve.
- Remove the O-rings.

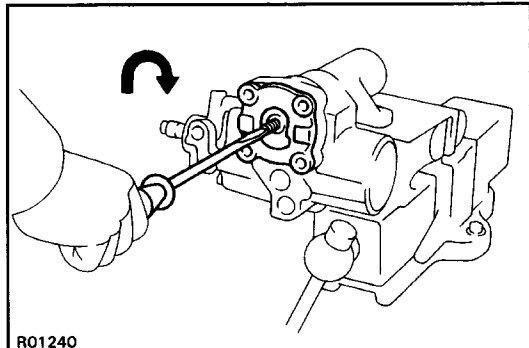

### 3. REMOVE END COVER

- Remove the adjusting screw lock nut.
- Remove the four bolts.
- Screw in the adjusting screw until the cover comes off.

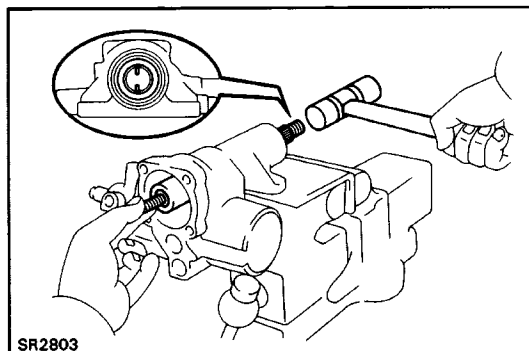

### 4. REMOVE CROSS SHAFT

Using a plastic hammer, tap on the cross shaft end and pull out the shaft.

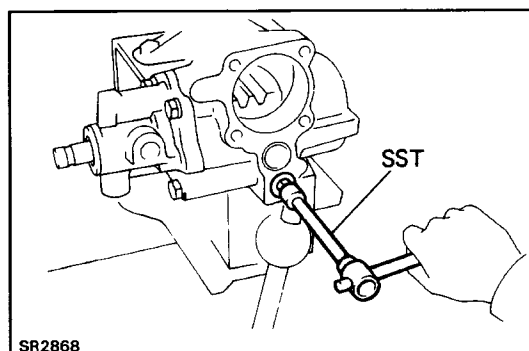

### 5. REMOVE PLUNGER GUIDE NUT

- Using SST, remove the plunger guide nut.  
SST 09043-38100
- Remove the spring, plunger and plunger guide.
- Remove the O-ring.

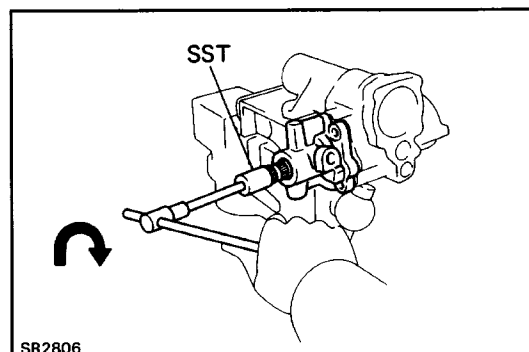

### 6. REMOVE WORM GEAR VALVE BODY ASSEMBLY

- Remove the four cap bolts from the housing.
- Using SST, turn the worm shaft clockwise with holding the power piston nut by your finger so it cannot move.  
SST 09616-00010



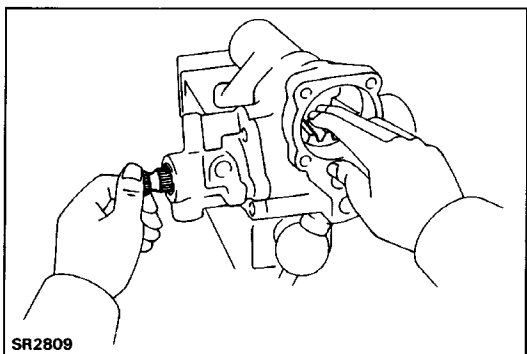

- (c) Pull out the valve body and power piston assembly.  
**NOTICE: Ensure that the power piston nut does not come off the worm shaft.**
- (d) Remove the O-ring.

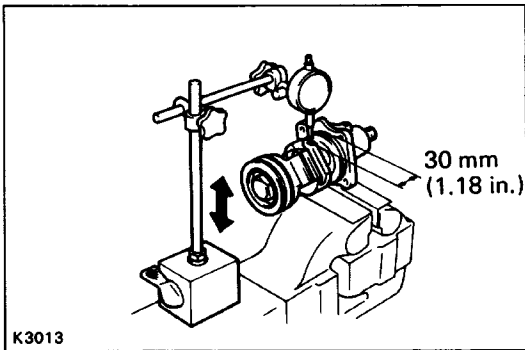

## INSPECTION AND REPLACEMENT OF GEAR HOUSING

### 1. CHECK BALL CLEARANCE

- (a) Mount the valve body in a vise.
- (b) Using a dial indicator, check the ball clearance.  
Move the worm gear up and down.

**Maximum ball clearance: 0.15 mm (0.0059 in.)**

If clearance is excessive, the power control valve assembly must be replaced.

### 2. INSPECT CROSS SHAFT ADJUSTING SCREW THRUST CLEARANCE

- (a) Clamp the cross shaft in a vise.
- (b) Using a dial indicator, measure the thrust clearance.

Thrust clearance: 0.03 – 0.05 mm

(0.0012 – 0.0020 in.)

If thrust clearance is not correct, adjust the thrust clearance.

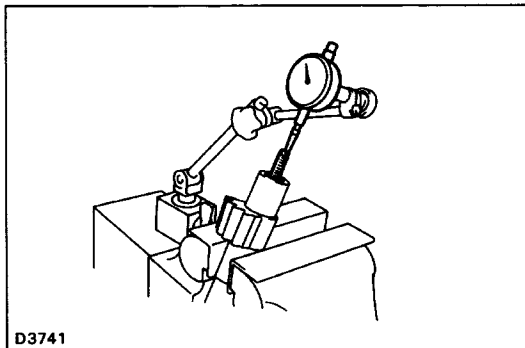

### 3. IF NECESSARY, ADJUST THRUST CLEARANCE

- (a) Using a chisel and hammer, remove the lock nut stake.

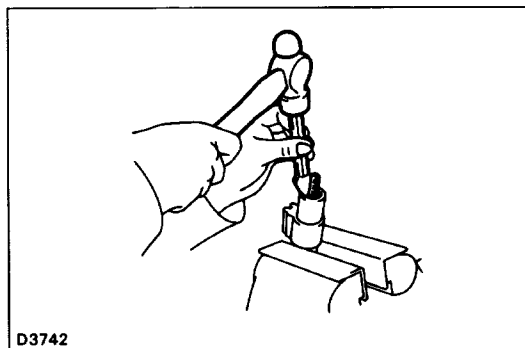

- (b) Using SST, remove the lock nut.

SST 09630-00012 (09631-00050)

- (c) Adjust the adjusting screw for correct thrust clearance and tighten a new lock nut.

- (d) Stake the lock nut.

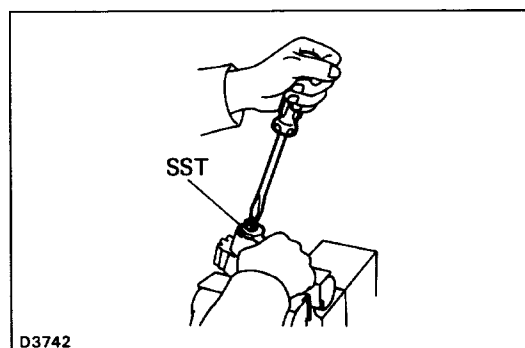

### 4. REPLACE NEEDLE ROLLER BEARINGS

- (a) Using a screwdriver, pry out the oil seal.
- (b) Using snap ring pliers, remove the snap ring.
- (c) Remove the metal spacer, teflon ring and O-ring.

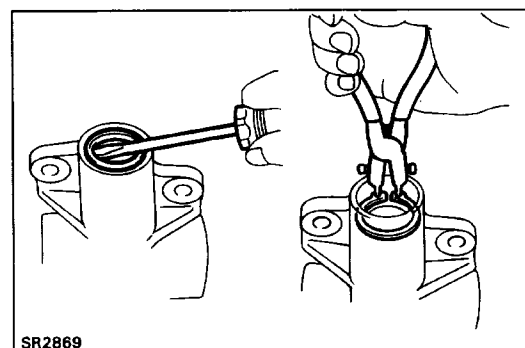

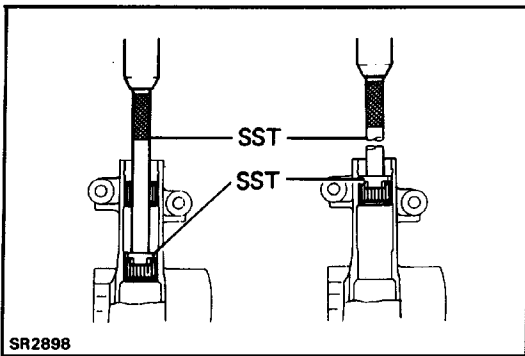

- (d) Using SST, press out the bearings.  
SST 09630-00012 (09631-00020, 09631-00070)

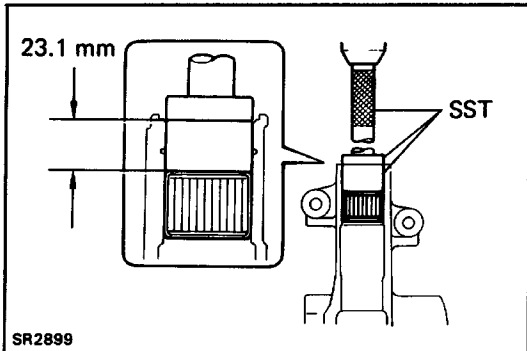

- (e) Using SST, press in a new lower bearing.  
SST 09630-00012 (09631-00020, 09631-00100, 09631-00170)

HINT: Install the lower bearing so that it is positioned 23.1 mm (0.909 in.) away from the housing inner end surface.

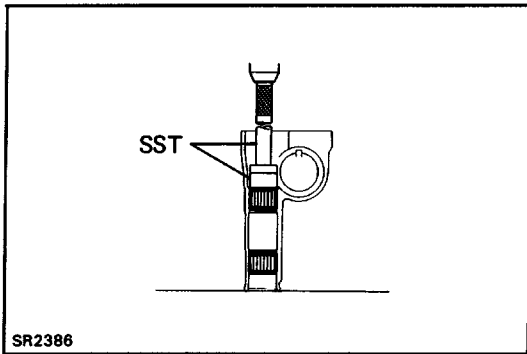

- (f) Using SST, press in a new upper bearing.  
SST 09630-00012 (09631-00020, 09631-00170)

HINT: The bearing's top end should be installed so that it aligns with the housing end surface.

- (g) Install a new O-ring and metal spacer.

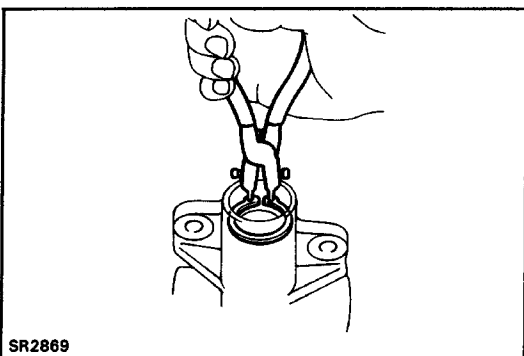

- (h) Using snap ring pliers, install the snap ring.

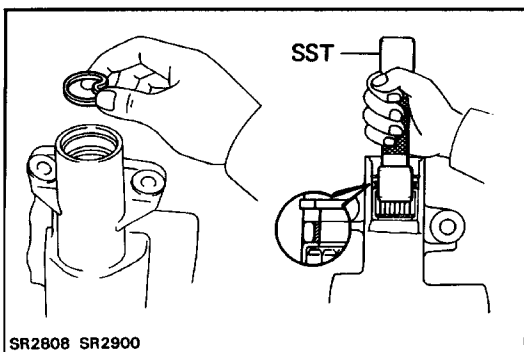

- (i) Form a new teflon ring into a heart shape and install it with hand.  
(j) Using SST, form the teflon ring.  
**NOTICE: The teflon ring must be squeezed before inserting the cross shaft or damage will result.**  
SST 09630-00012 (09631-00120)

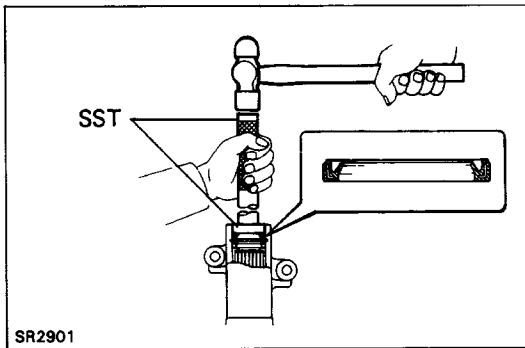

- (k) Using SST, drive a new oil seal into the gear housing.  
SST 09630-00012 (09631-00020, 09631-00170)

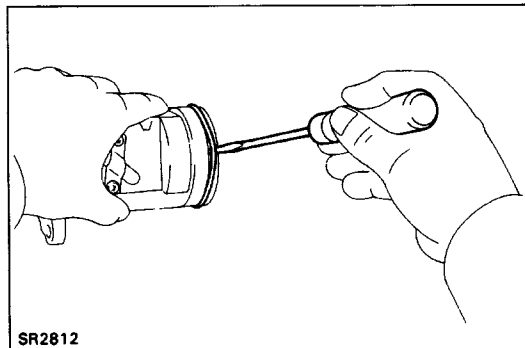

### 5. IF NECESSARY, REPLACE CONTROL VALVE TEFLON RING AND O-RING

- (a) Using a screwdriver, remove the teflon ring and O-ring.  
**NOTICE: Be careful not to damage the control valve.**  
(b) Install a new O-ring.  
(c) Expand a new teflon ring with your fingers.  
**NOTICE: Be careful not to over-expand the teflon ring.**  
(d) Install the teflon ring.

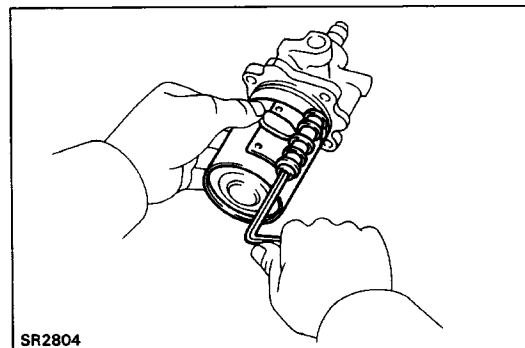

- (e) Coat the teflon ring with power steering fluid and snug it down with piston ring compressor for 5 - 7 minutes.

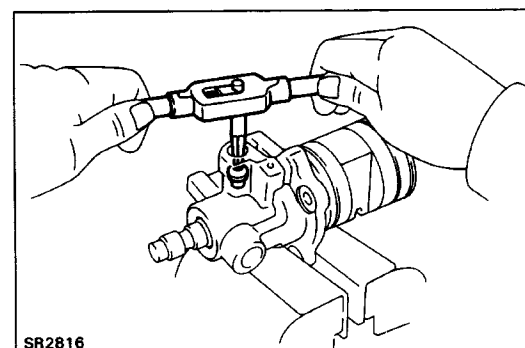

### 6. IF NECESSARY, REPLACE UNION SEAT

- (a) Using a screw extractor, remove the union seat.

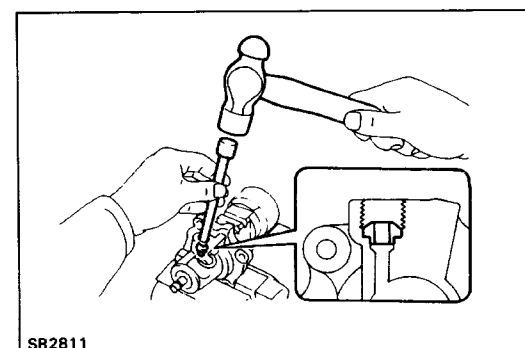

- (b) Using a plastic hammer and extension bar, tap in a new union seat.

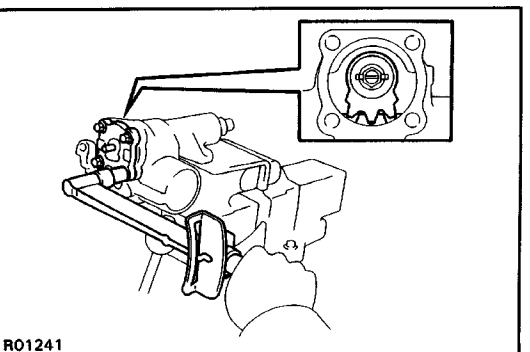
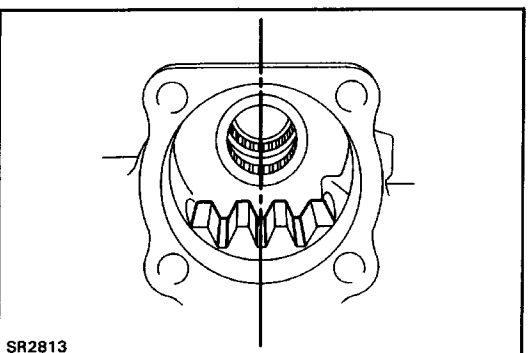
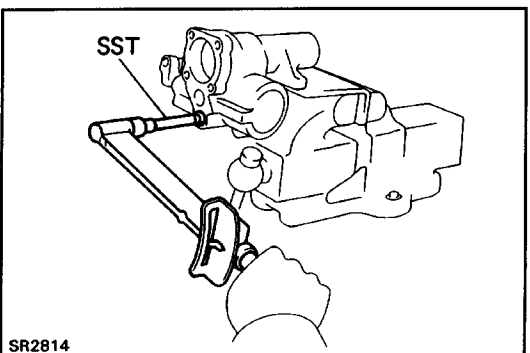
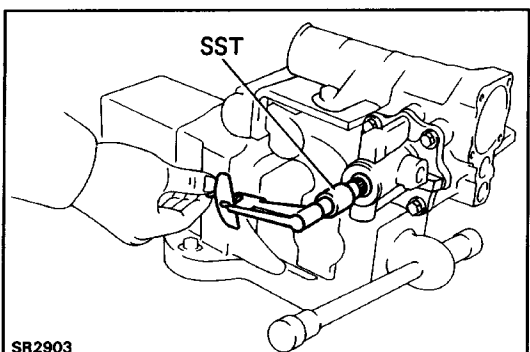
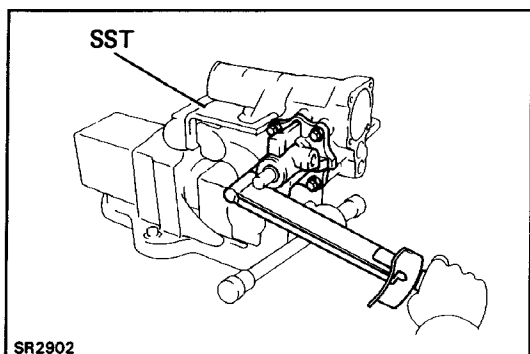

## ASSEMBLY OF GEAR HOUSING

(See page SR-67)

### 1. INSTALL WORM GEAR VALVE BODY ASSEMBLY

- Install the three O-rings to the gear housing and valve body.
- Mount the gear housing on SST and clamp SST in vise.  
SST 09630-00012 (09631-00140)
- Install and torque the four bolts.  
**Torque: 46 N-m (470 kgf-cm, 34 ft-lbf)**  
**NOTICE: Be careful not to damage the teflon ring.**
- Using SST, check the worm gear preload.  
SST 09616-00010  
**Preload (Starting): 0.3 - 0.5 N-m**  
**(3 - 5.5 kgf-cm, 2.6 - 4.8 in.-lbf)**

HINT: Hold the power piston nut to prevent it from turning.

If preload is not correct, replace the worm gear assembly.

### 2. INSTALL PLUNGER GUIDE NUT

- Install the plunger, plunger guide and spring.
- Install a new O-ring to the plunger guide nut and install the plunger guide nut with SST.  
SST 09043-38100  
**Torque: 20 N-m (205 kgf-cm, 15 ft-lbf)**

### 3. INSTALL CROSS SHAFT AND END COVER

- Install a new O-ring on the end cover.
- Assemble the cross shaft to the end cover.  
HINT: Fully loosen the adjusting screw.
- Set the worm gear at the center of the gear housing.

- Install and push the cross shaft into the gear housing so that the center teeth mesh together.
- Install the four bolts. Torque the bolts in a diagonal pattern.

**Torque: 46 N-m (470 kgf-cm, 34 ft-lbf)**

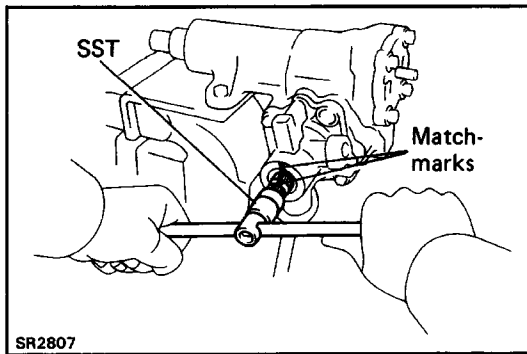

#### 4. DETERMINE CENTER POSITION OF GEAR HOUSING

- (a) Using SST, turn the worm shaft so full lock in both directions and determine the exact center.  
SST 09616-00010
- (b) Place matchmarks on the worm shaft and housing to show neutral position.

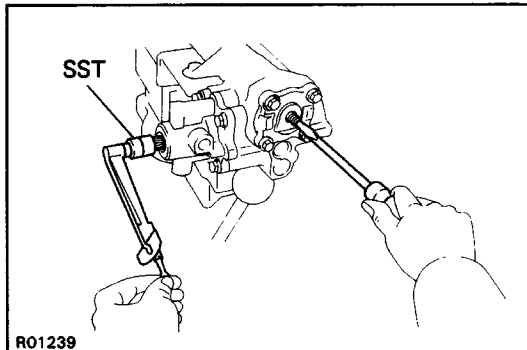

#### 5. ADJUST CROSS SHAFT ADJUSTING SCREW

- (a) Install SST with a torque meter on the worm shaft.  
SST 09616-00010
- (b) Turn the adjusting screw while measuring the pre-load until it should be increased 0.2 – 0.4 N-m (2 – 4 kgf-cm, 1.7 – 3.5 in.-lbf) more than the preload listed in step 1.

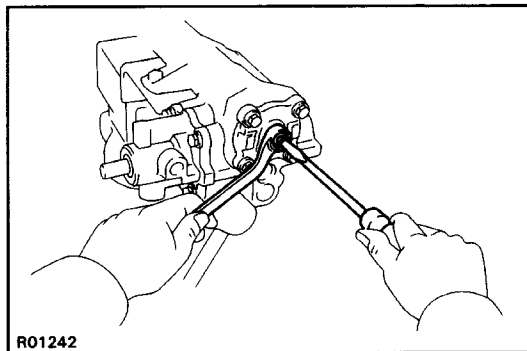

#### 6. INSTALL NEW WASHER

#### 7. INSTALL AND TIGHTEN LOCK NUT

Torque the lock nut while holding the adjusting screw.  
**Torque: 46 N-m (470 kgf-cm, 34 ft-lbf)**

#### 8. CHECK TOTAL PRELOAD

Using SST and a torque meter, check total preload.

SST 09616-00010

**Total preload (Starting):**

**0.5 – 0.9 N-m (5 – 9.5 kgf-cm, 4.3 – 8.3 in.-lbf)**

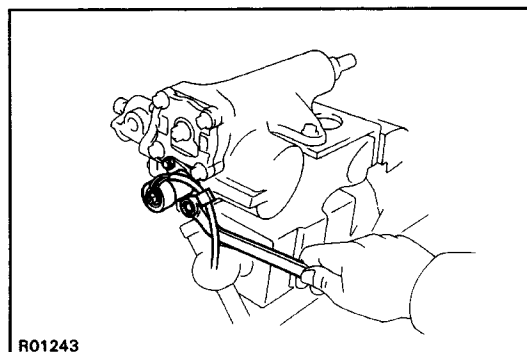

#### 9. INSTALL SOLENOID VALVE (w/ PPS)

- (a) Install new O-rings to the solenoid valve.
- (b) Install the solenoid valve with the two bolts.

# Gear Housing (4WD)

## REMOVAL AND INSTALLATION OF GEAR HOUSING

Remove and install the parts as shown.

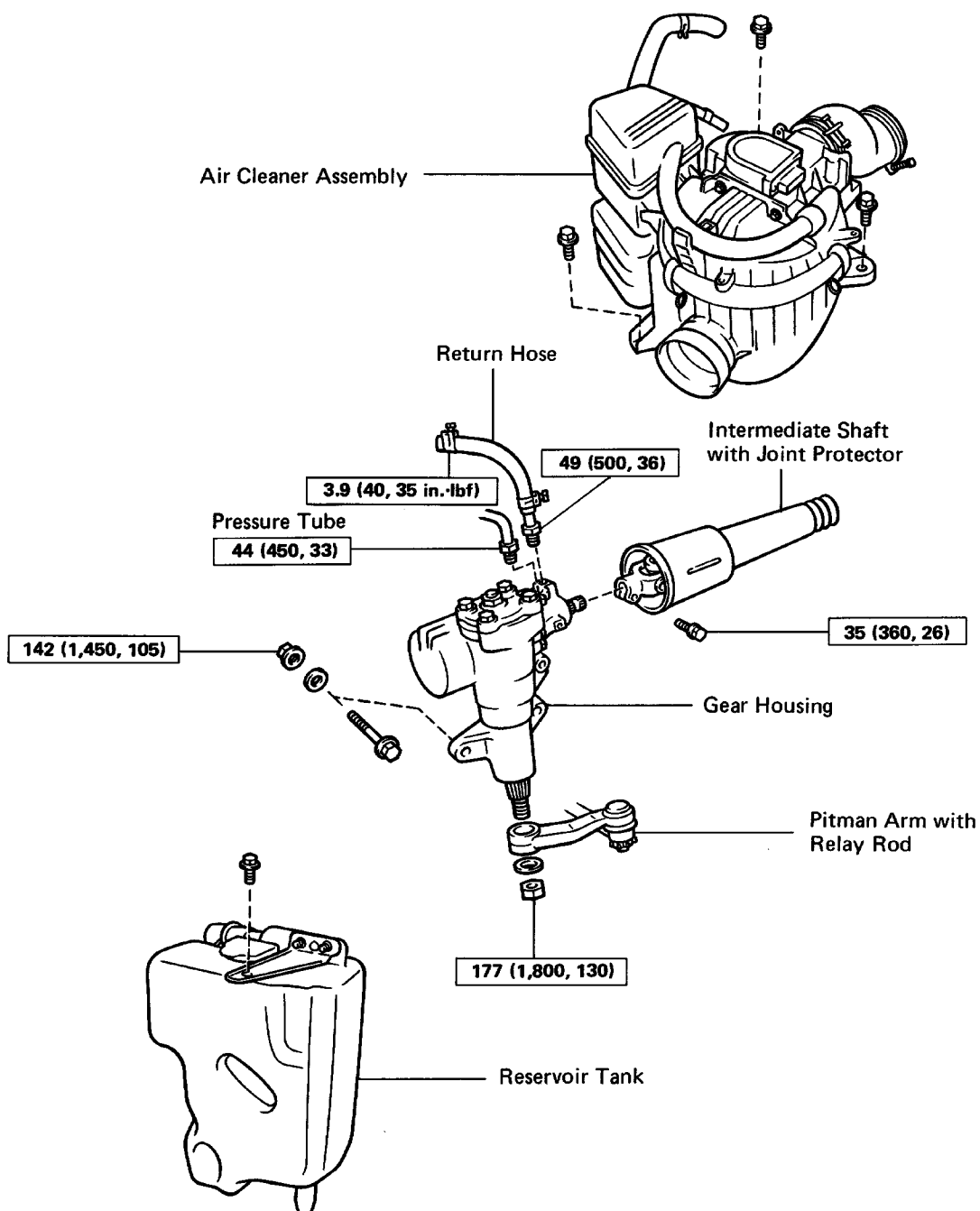

N·m (kgf·cm, ft·lbf) : Specified torque

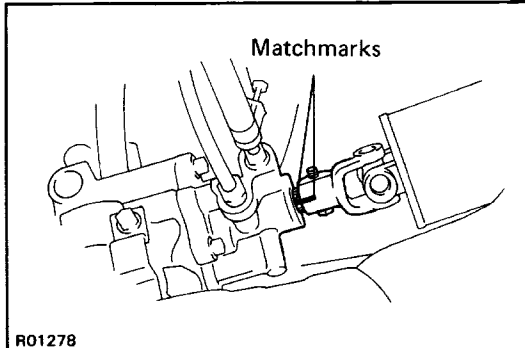
**(MAIN POINT OF REMOVAL AND INSTALLATION)****1. REMOVE RESERVOIR TANK****2. REMOVE AIR CLEANER ASSEMBLY****3. DISCONNECT UNIVERSAL JOINT**

- Loosen the column side set bolt.
- Remove the gear side set bolt.
- Place matchmarks on the universal joint and worm shaft.
- Slide the shaft rearward to disconnect the shaft from the worm shaft.

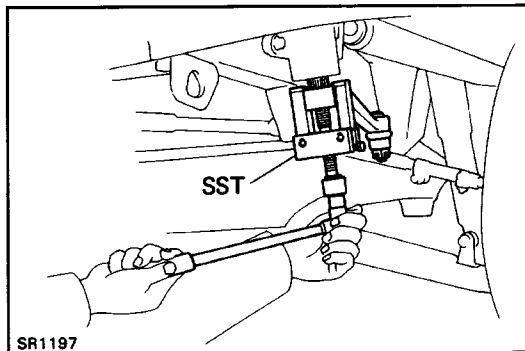
**4. DISCONNECT AND CONNECT PITMAN ARM**

- Remove the pitman arm set nut.
- Using SST, disconnect the pitman arm from the gear housing.  
SST 09628-62011

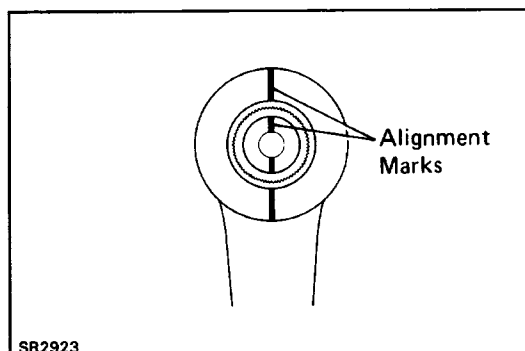

- When connecting, align the alignment marks on the sector shaft and pitman arm and install it.

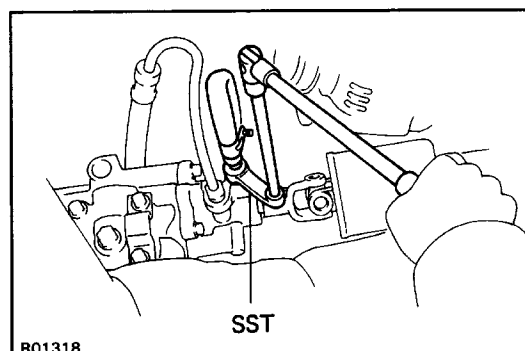
**5. DISCONNECT PRESSURE TUBE FROM GEAR HOUSING**

Using SST, disconnect the pressure tube from the gear housing.

SST 09631-22020



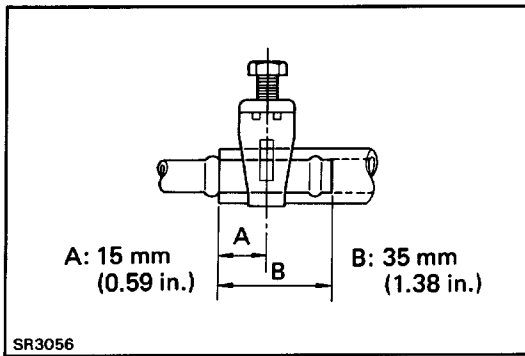

## 6. DISCONNECT AND CONNECT RETURN HOSE

- Using a screwdriver, loosen the clamp and disconnect the return hose.
- When connecting, check that hose and tube connections are as shown and tighten the screw.

**NOTICE:** At installation, be sure that the clamp does not touch the other parts.

# COMPONENTS

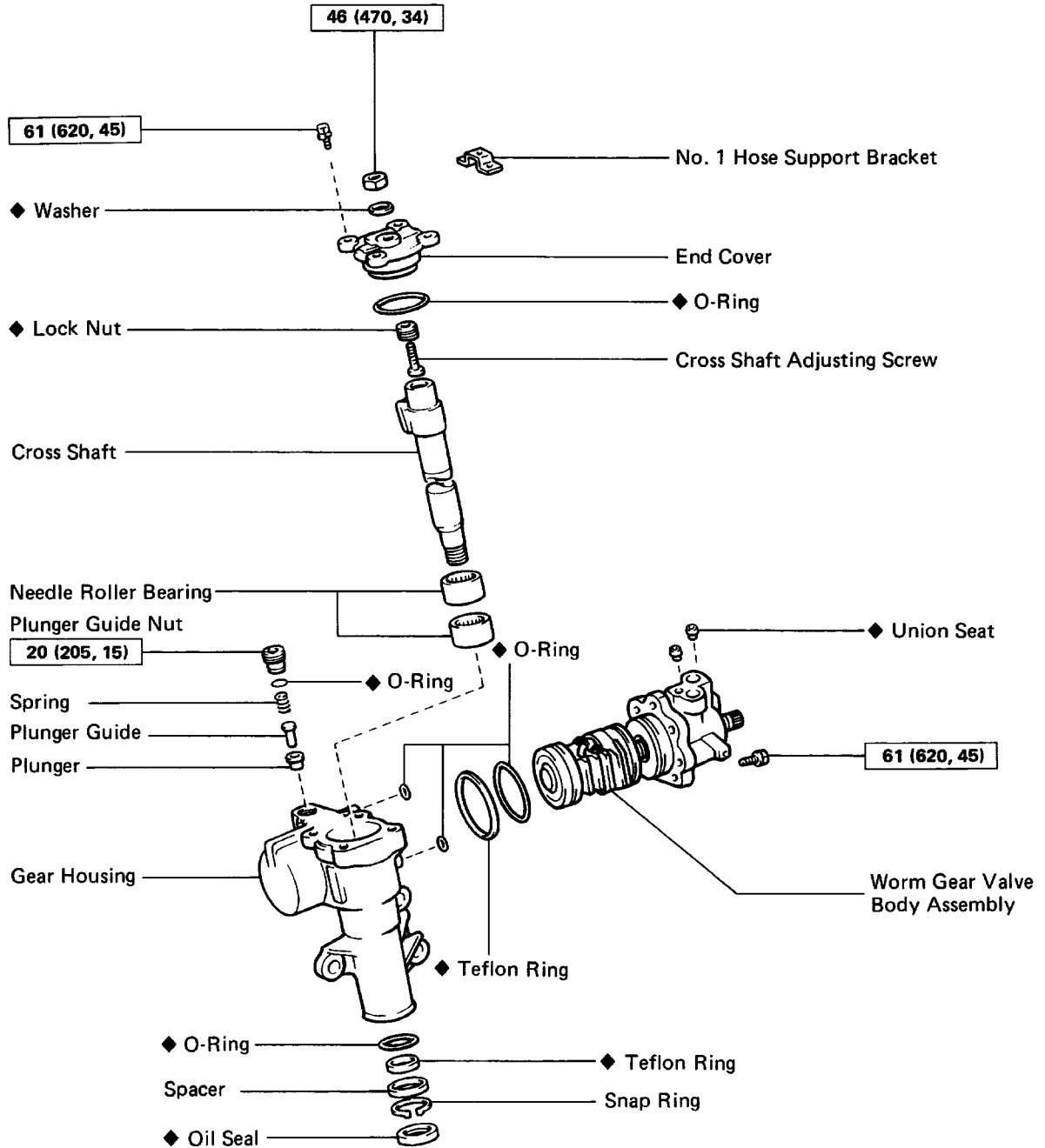

N·m (kgf·cm, ft·lbf) : Specified torque

◆ Non-reusable part

## DISASSEMBLY OF GEAR HOUSING

(See page [SR-76](#))

### 1. MOUNT HOUSING ON STAND

Mount the gear housing on SST and clamp SST in a vise.  
SST 09630-00012 (09631-00140)

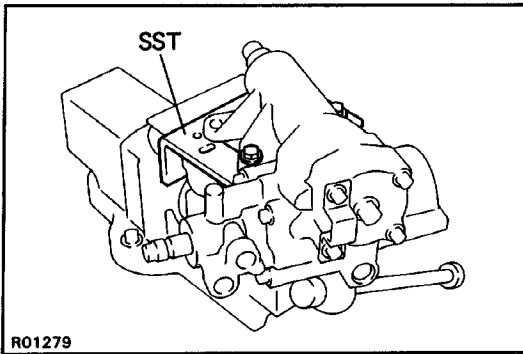

### 2. REMOVE END COVER

(a) Remove the adjusting screw lock nut.

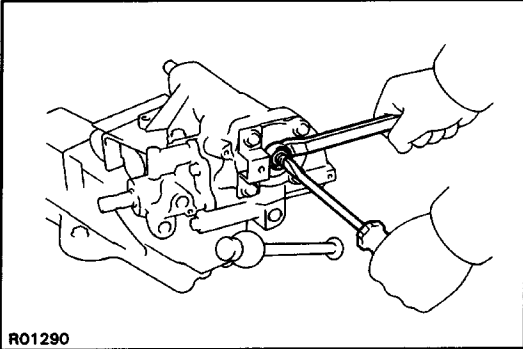

(b) Remove the four bolts and No. 1 hose support bracket.

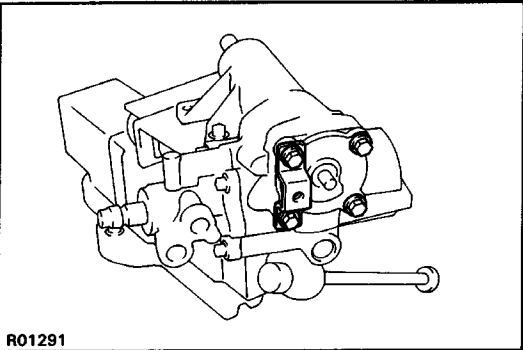

(c) Screw in the adjusting screw until the cover comes off.

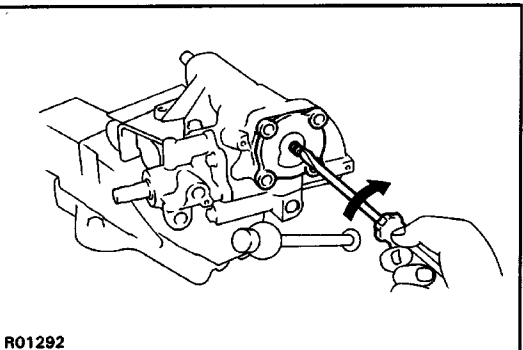

### 3. REMOVE CROSS SHAFT

Using a plastic hammer, tap on the cross shaft end and pull out the shaft.

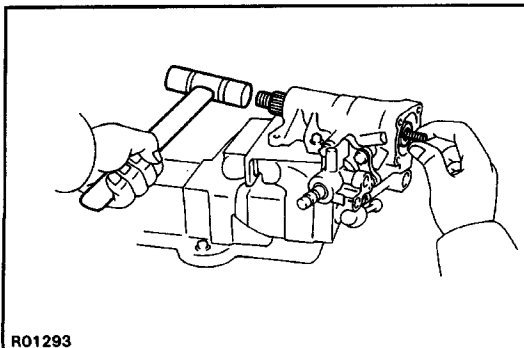

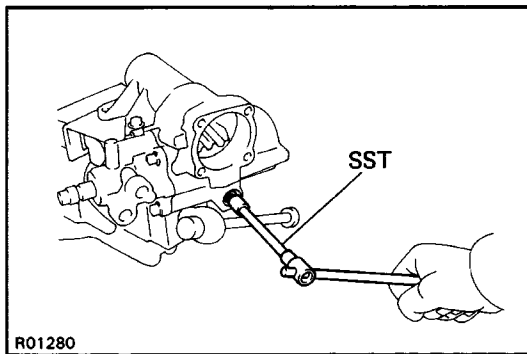

#### 4. REMOVE PLUNGER GUIDE NUT

- (a) Using SST, remove the plunger guide nut.  
SST 09043-38100

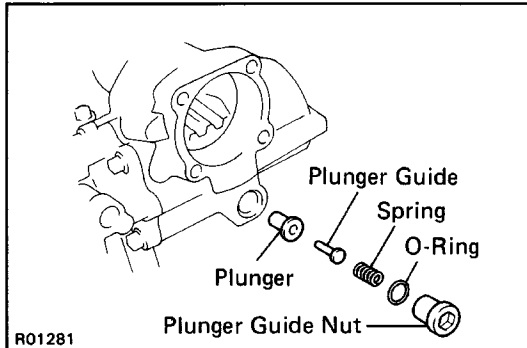

- (b) Remove the spring, plunger and plunger guide nut.  
(e) Remove the O-ring.

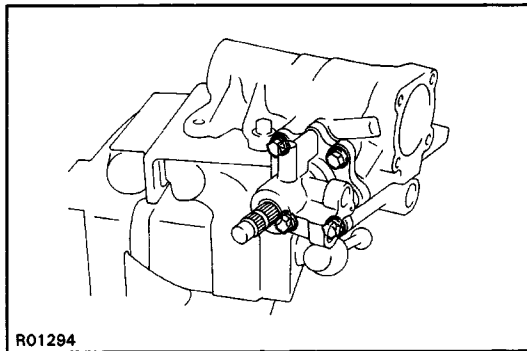

#### 5. REMOVE WORM GEAR VALVE BODY ASSEMBLY

- (a) Remove the four cap bolts from the housing.

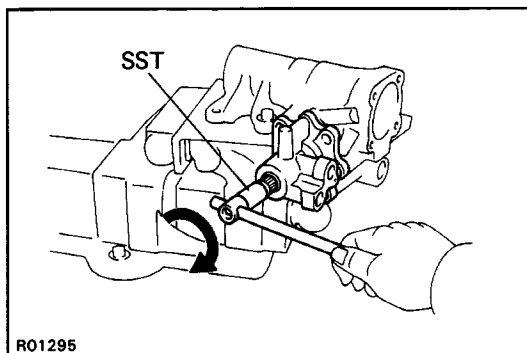

- (b) Using SST, turn the shaft clockwise to disconnect the worm gear valve body assembly from the gear housing.  
SST 09616-00010

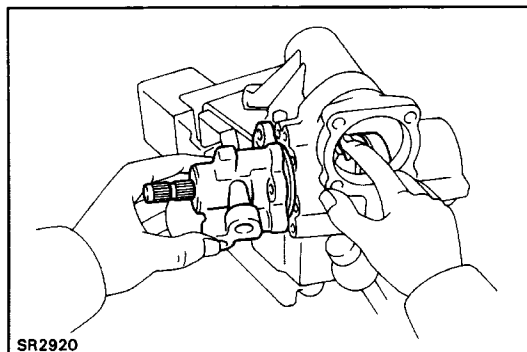

- (c) Hold the power piston nut with your thumb so it cannot move, then withdraw the valve body and power piston assembly.  
**NOTICE: Ensure that the power piston nut does not come off the worm shaft.**  
(d) Remove the O-ring.

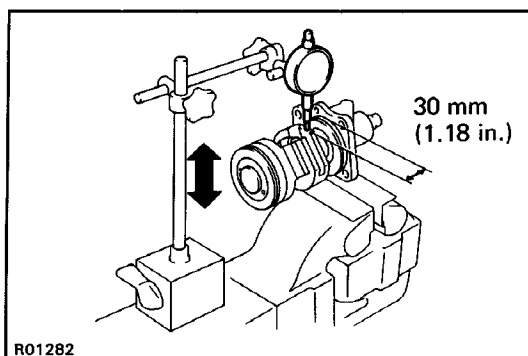

## INSPECTION AND REPLACEMENT OF GEAR HOUSING

### 1. CHECK BALL CLEARANCE

- Mount the valve body in a vise.
- Using a dial indicator, check the ball clearance.  
Move the worm gear up and down.  
**Maximum ball clearance: 0.15 mm (0.0059 in.)**  
If clearance is excessive, the power control valve assembly must be replaced.

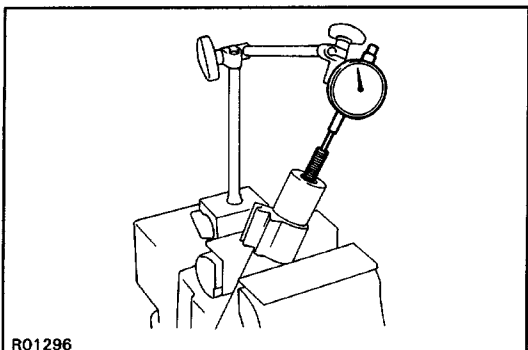

### 2. INSPECT CROSS SHAFT ADJUSTING SCREW THRUST CLEARANCE

- Clamp the cross shaft in a vise.
- Using a dial indicator, measure the thrust clearance.  
**Thrust clearance: 0.03 – 0.05 mm (0.0012 – 0.0020 in.)**  
If thrust clearance is not correct, adjust the thrust clearance.

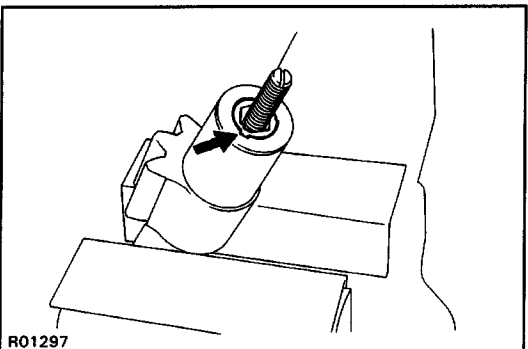

### 3. IF NECESSARY, ADJUST THRUST CLEARANCE

- Using a chisel and hammer, remove the lock nut stake.
- Using SST, remove the lock nut.  
SST 09630-00012 (09631-00050)
- Adjust the adjusting screw for correct thrust clearance and tighten a new lock nut.
- Stake the lock nut.

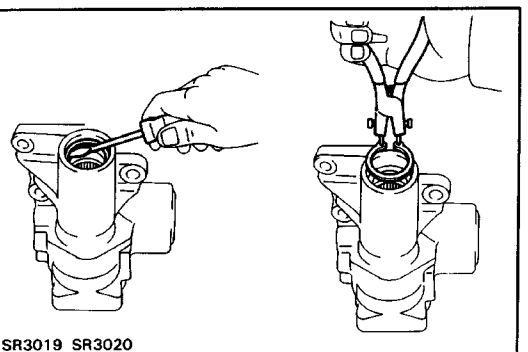
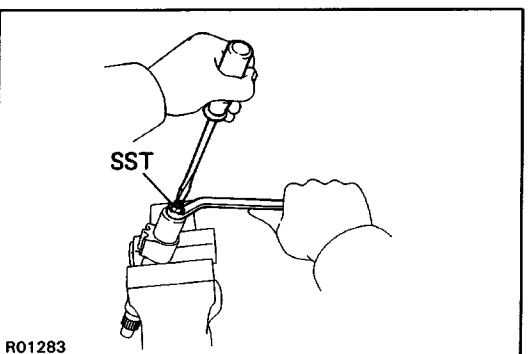

### 4. IF NECESSARY, REPLACE NEEDLE ROLLER BEARINGS

- Using a screwdriver, pry out the oil seal.
- Using snap ring pliers, remove the snap ring.
- Remove the metal spacer, teflon ring and O-ring.

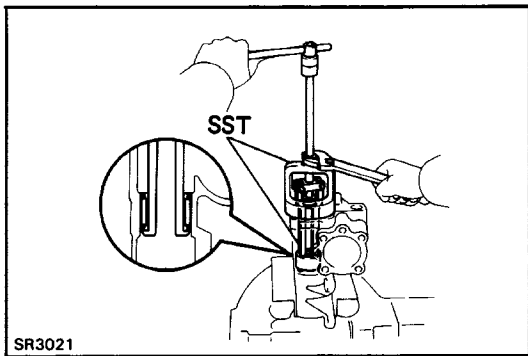

- (d) Using SST, remove the upper bearing.  
SST 09612-65014 (09612-01030)

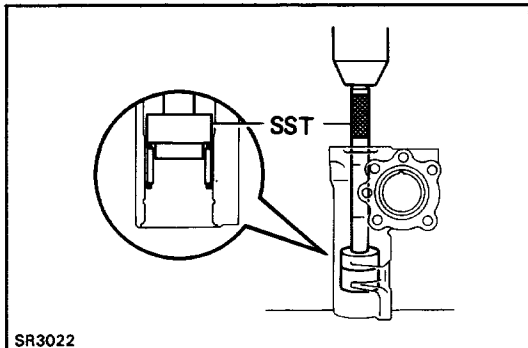

- (e) Using SST, press out the lower bearing.  
SST 09630-00012 (09631-00020, 09631-00090)

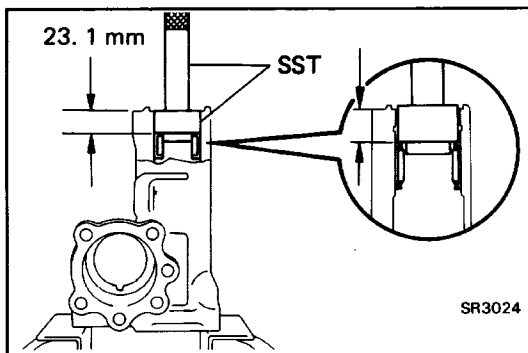

- (f) Using SST, press in a new lower bearing.  
SST 09630-00012 (09631-00020, 09631-00090)  
HINT: Install the lower bearing so that it is positioned 23.1 mm (0.909 in.) away from the housing inner end surface.

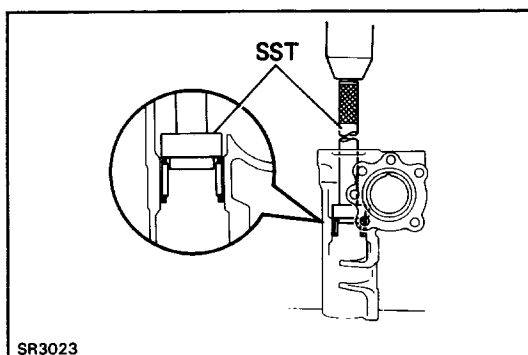

- (g) Using SST, press in a new upper bearing.  
SST 09630-00012 (09631-00020, 09631-00090)

HINT: The bearing's top end should be installed so that it aligns with the housing end surface.

- (h) Install a new O-ring and metal spacer.

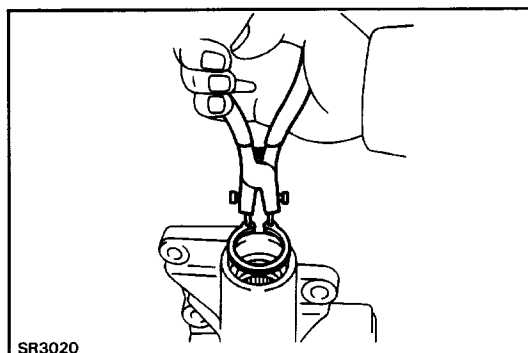

- (i) Using snap ring pliers, install the snap ring.

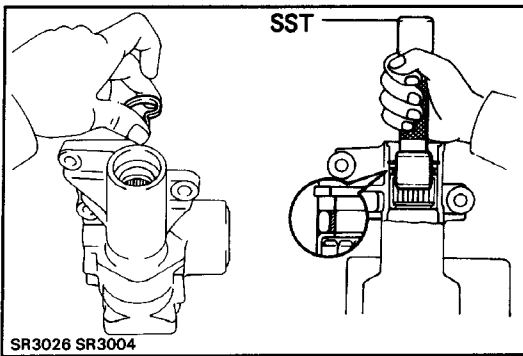

- (j) Form a new teflon ring into a heart shape and install it with hand.
- (k) Using SST, form the teflon ring.  
**NOTICE: The teflon ring must be squeezed before inserting the cross shaft or damage will result.**  
 SST 09630-00012 (09631-00120)

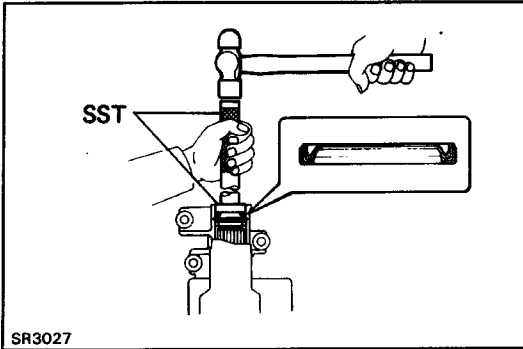

- (l) Using SST, drive a new oil seal into the gear housing.  
 SST 09630-00012 (09631-00020, 09631-00090)

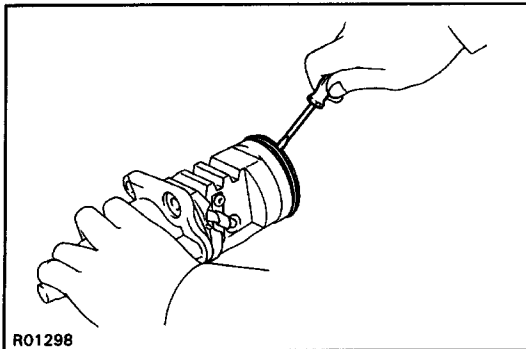

#### 5. IF NECESSARY, REPLACE CONTROL VALVE TEFLON RING AND O-RING

- (a) Using a screwdriver, remove the teflon ring and O-ring.  
**NOTICE: Be careful not to damage the control valve.**
- (b) Install a new O-ring.
- (c) Expand a new teflon ring with your fingers.  
**NOTICE: Be careful not to over-expand the teflon ring.**
- (d) Install the teflon ring.
- (e) Coat the teflon ring with power steering fluid and snug it down with piston ring compressor for 5 - 7 minutes.

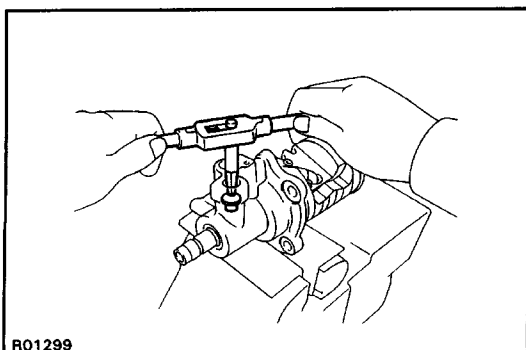
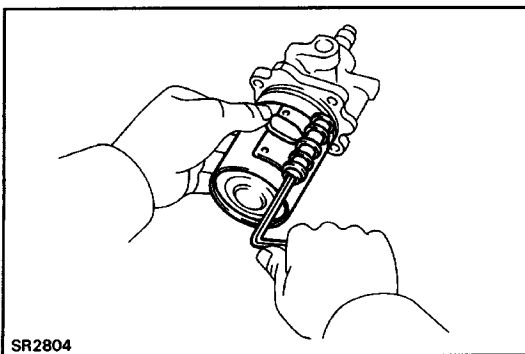

#### 6. IF NECESSARY, REPLACE UNION SEAT

- (a) Using a screw extractor, remove the union seat.

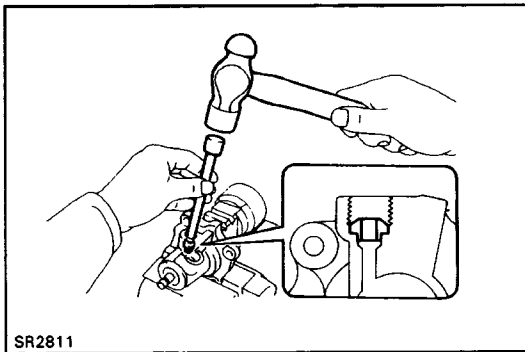

- (b) Using a plastic hammer and extension bar, tap in a new union seat.

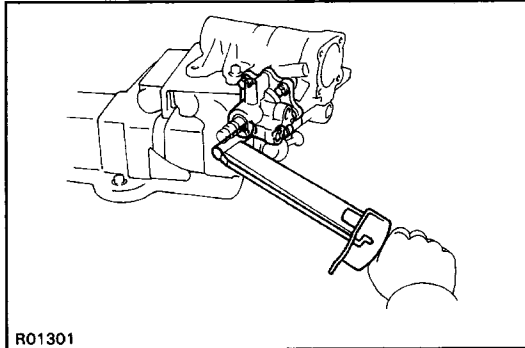

## ASSEMBLY OF GEAR HOUSING

(See page [SR-76](#))

### 1. INSTALL WORM GEAR VALVE BODY ASSEMBLY

- (a) Install the three O-rings to the gear housing and valve body.

- (b) Mount the gear housing on SST and clamp SST in vise.

SST 09630-00012 (09631-00140)

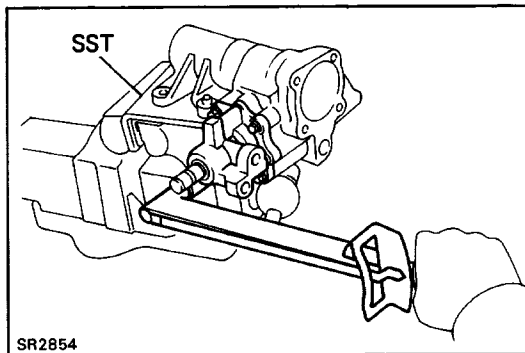

- (c) Install and torque the four bolts.

**Torque: 61 N-m (620 kgf-cm, 45 ft-lbf)**

**NOTICE: Be careful not to damage the teflon ring.**

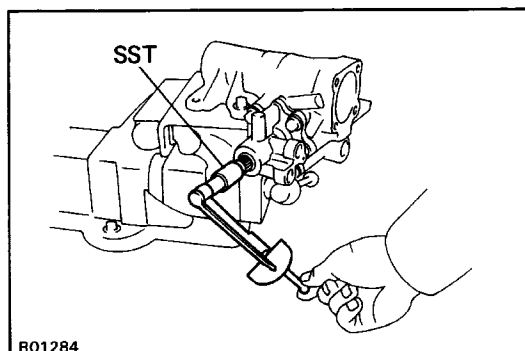

- (d) Using SST, check the worm gear preload.

SST 09616-00010

**Preload (Starting): 0.3 - 0.5 N-m**

**(3 - 5.5 kgf-cm, 2.6 - 4.8 in. AM)**

**HINT: Hold the power piston nut to prevent it from turning.**

If preload is not correct, replace the worm gear assembly.

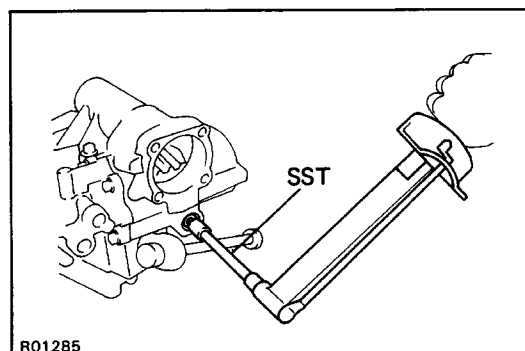

### 2. INSTALL PLUNGER GUIDE NUT

- (a) Install the plunger, plunger guide and spring.

- (b) Install a new O-ring to the plunger guide nut and install the plunger guide nut with SST.

SST 09043-38100

**Torque: 20 N-m (205 kgf-cm, 15 ft-lbf)**



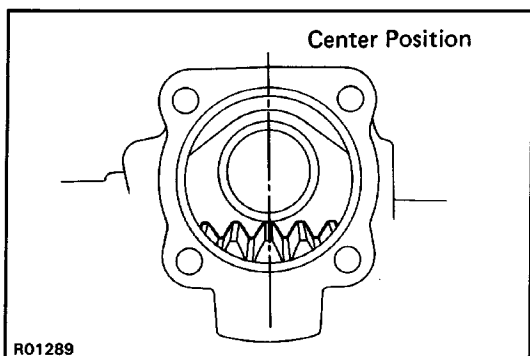

### 3. INSTALL CROSS SHAFT AND END COVER

- Install a new O-ring on the end cover.
- Assemble the cross shaft to the end cover.  
HINT: Fully loosen the adjusting screw.
- Set the worm gear at the center of the gear housing.

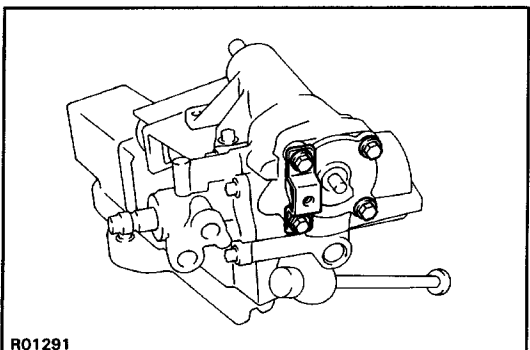

- Install and push the cross shaft into the gear housing so that the center teeth mesh together.
- Install the four cap bolts. Torque the bolts in a diagonal pattern.

**Torque: 61 N-m (620 kgf-cm, 45 ft-lbf)**

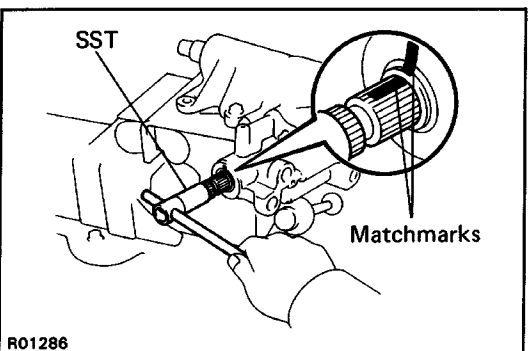

### 4. DETERMINE CENTER POSITION OF GEAR HOUSING

- Using SST, turn the worm shaft so full lock in both directions and determine the exact center.  
SST 09616-00010
- Place matchmarks on the worm shaft and housing to show neutral position.

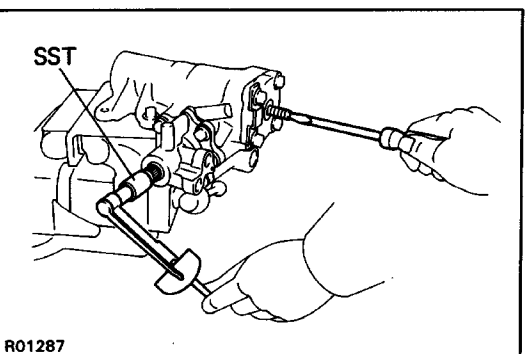

### 5. ADJUST CROSS SHAFT ADJUSTING SCREW

- Install SST with a torque meter on the worm shaft.  
SST 09616-00010
- Turn the adjusting screw while measuring the preload until it should be increased 0.2 - 0.4 N-m (2 - 4 kgf-cm, 1.7 - 3.5 in.-lbf) more than the preload listed in step 1.

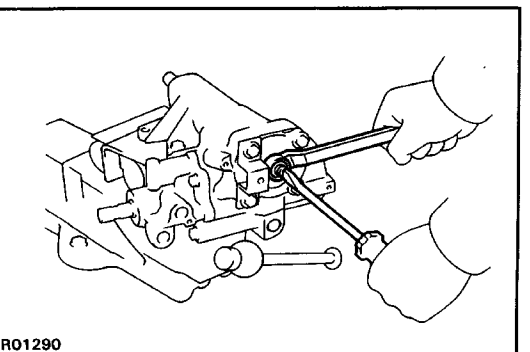

### 6. INSTALL NEW WASHER

### 7. INSTALL AND TIGHTEN LOCK NUT

- Torque the lock nut while holding the adjusting screw.  
**Torque: 46 N-m (470 kgf-cm, 34 ft-lbf)**

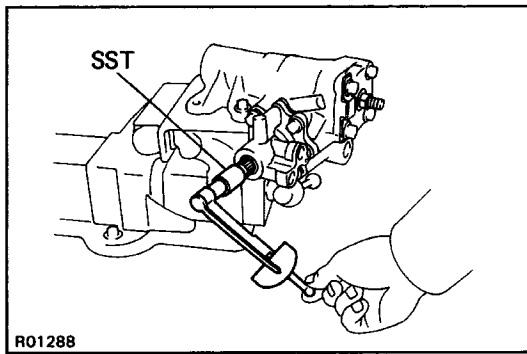

## 8. CHECK TOTAL PRELOAD

Using SST with a torque meter, check total preload.

SST 09616-00010

**Total preload (Starting):**

**0.5 – 0.9 N-m (5 – 9.5 kgf-cm, 4.3 – 8.3 in.-lbf)**

# Progressive Power Steering (PPS) DESCRIPTION AND ELECTRONIC CIRCUIT

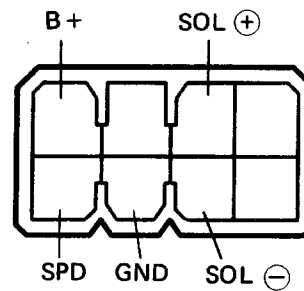
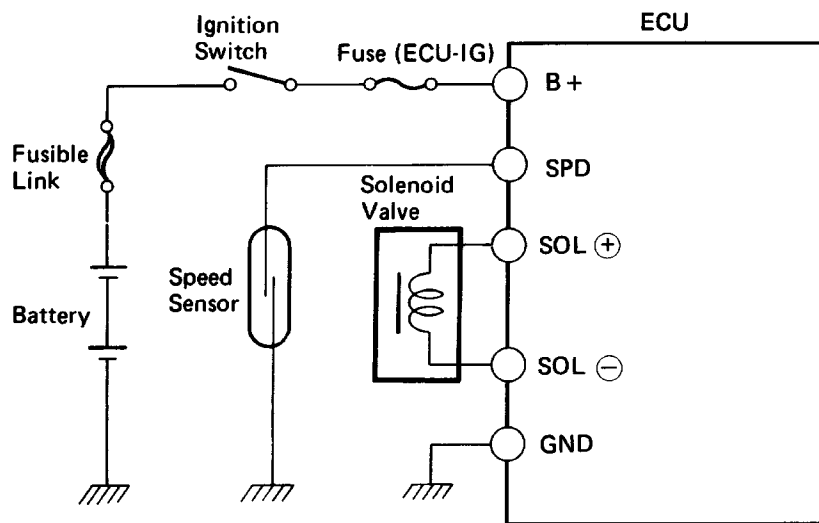
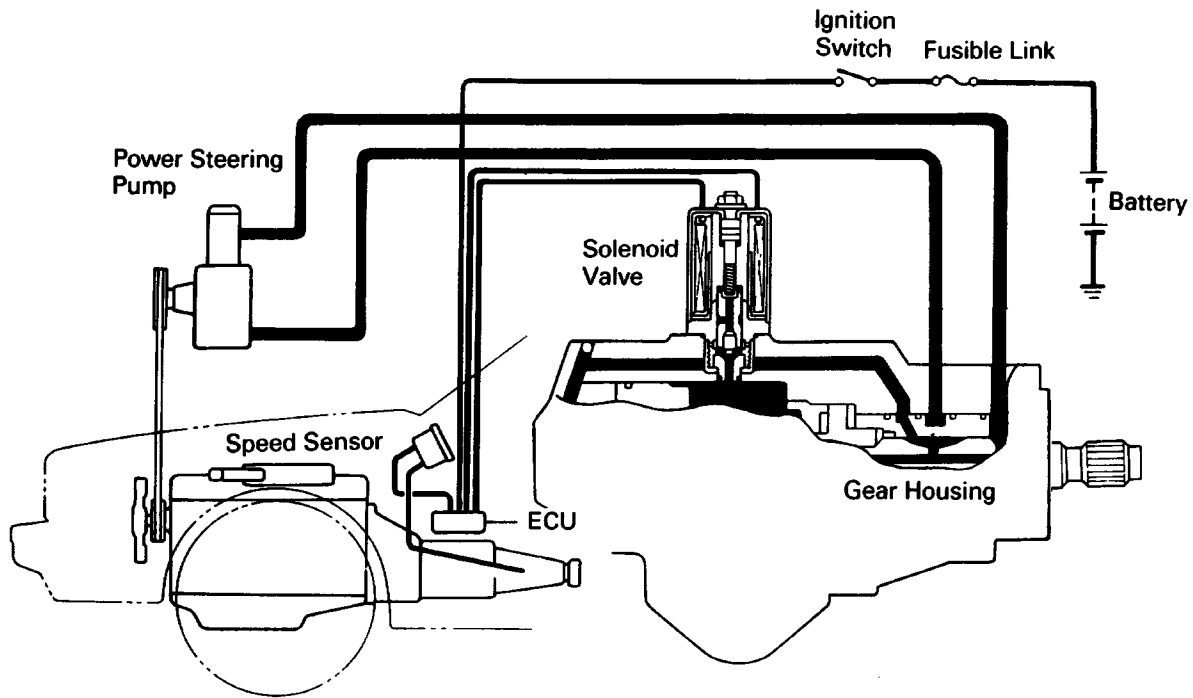

# TROUBLESHOOTING

## Trouble

- Hard steering at idle or low-speed driving.
- Steering too sensitive during high-speed driving.

## Preliminary Check

- Check tire pressure.
- Check lubrication of suspension and steering linkage.
- Check front wheel alignment.
- Check steering system joint and suspension arm ball joint.
- Check for bent steering column.
- Check that all connectors are secure.
- Check PS pump fluid pressure. (See page [SR-41](#))

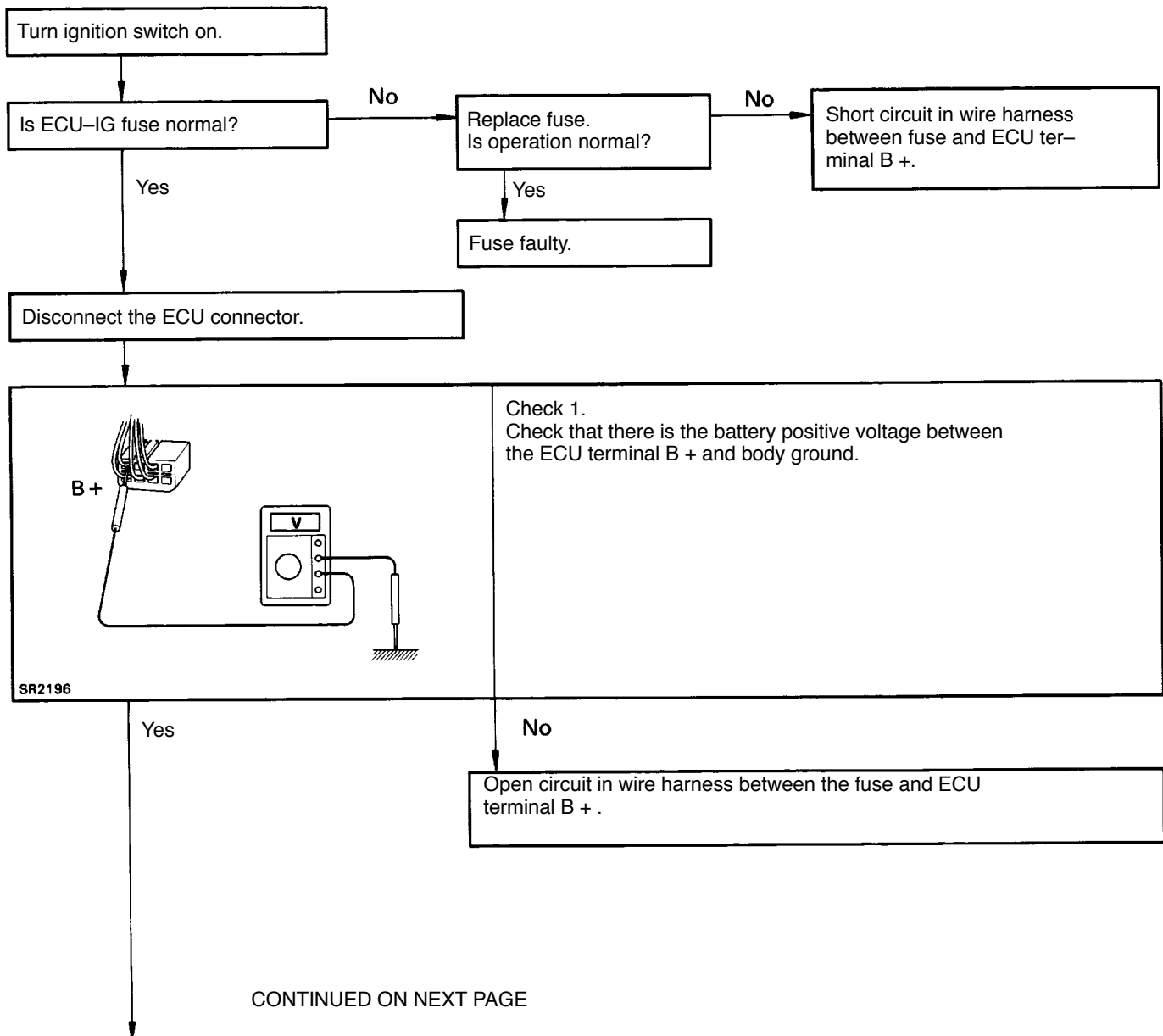

Yes CONTINUED FROM PREVIOUS PAGE

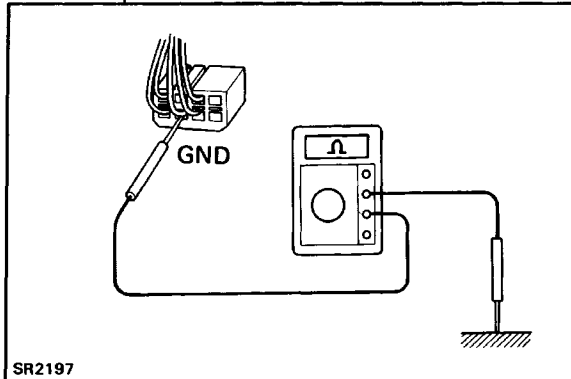

Check 2.  
Check that there is continuity between the ECU terminal G ND and body ground.

Yes

No

- Open circuit in wire harness between the ECU terminal GND and body ground.
- Body ground faulty.

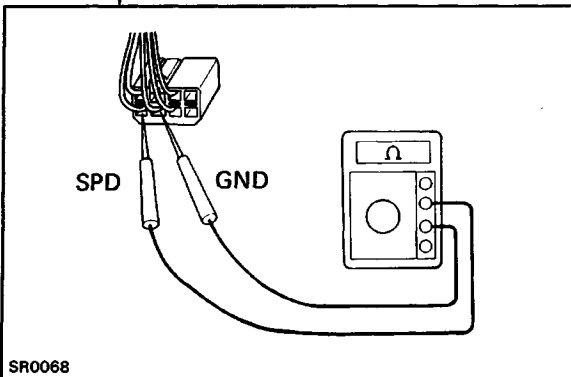

Check 3.  
(a) Jack up the rear wheel on one side.  
(b) Connect an ohmmeter between the ECU connector terminals SPD and GND.  
(c) Spin the rear wheel and check that the meter needle deflects from 0 / to  $\infty$  / .

Yes

No

- Open or short circuit in wire harness between the ECU terminal SPD and speed sensor.
- Speed sensor faulty (See page [BE-34](#)).

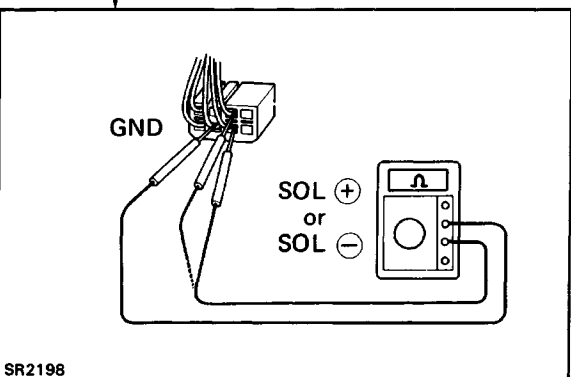

Check 4.  
Check that there is no continuity between terminals SOL + or SOL - and GND.

Yes

No

- Short circuit in wire harness between the terminals SOL + and SOL - .
- Solenoid valve faulty.

CONTINUED ON NEXT PAGE

Yes CONTINUED FROM PREVIOUS PAGE

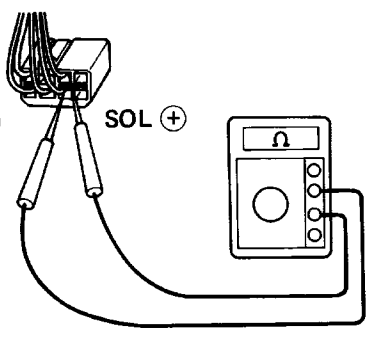

SOL - SOL +

SR0069

Check 5.  
Measure the resistance between terminals SOL + and SOL -.  
Standard resistance: 6 - 11 Ω

Yes

No

- Open circuit in wire harness between the terminals SOL + and SOL -.
- Solenoid valve faulty.

Check 6.  
Inspect ECU.

Bad

Replace ECU .

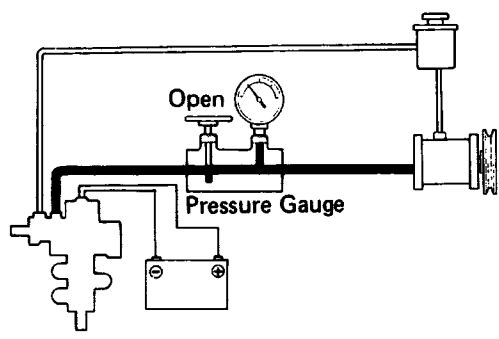

Open Pressure Gauge

B8497

Check 7.  
(a) Turn the steering wheel full lock position.  
(b) Apply battery positive voltage between terminals SOL + and SOL - and turn the solenoid ON and OFF. Is there a change in gear housing fluid pressure when the solenoid is ON or OFF?

Yes

No

Steering gear housing faulty.

- By-pass or return line clogged.
- Fluid level low.
- Solenoid valve faulty.

## ELECTRONIC CONTROL SYSTEM

### Solenoid Valve

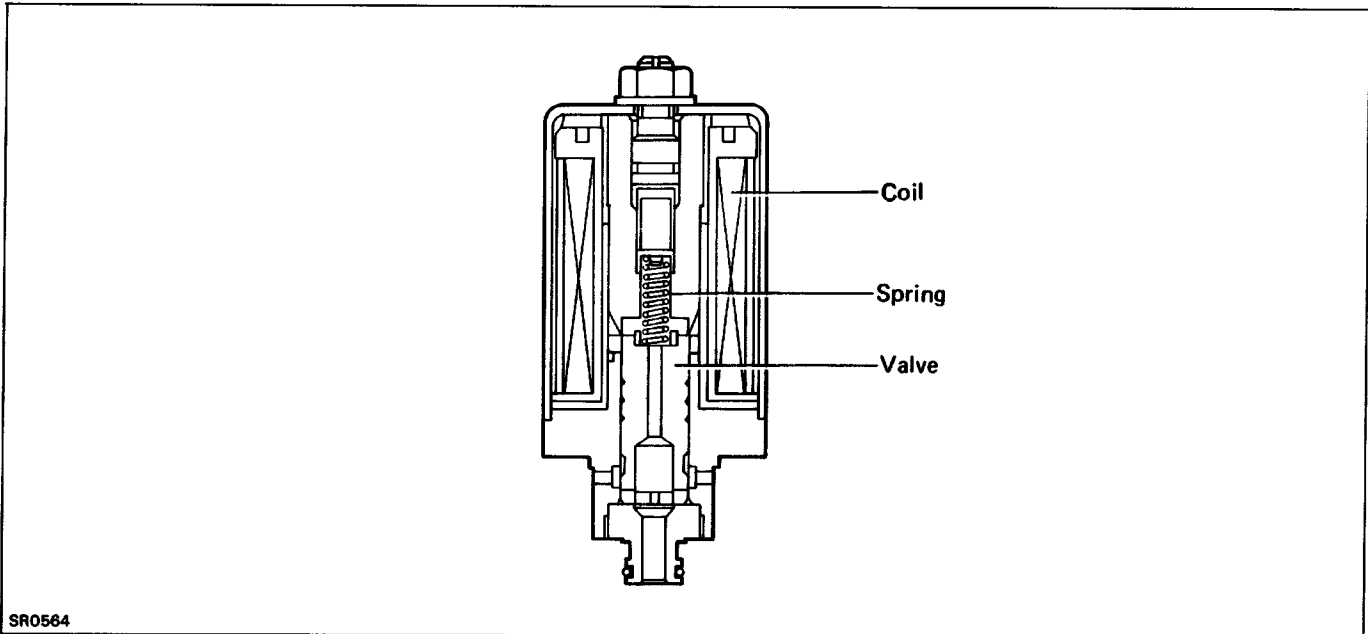

SR0564

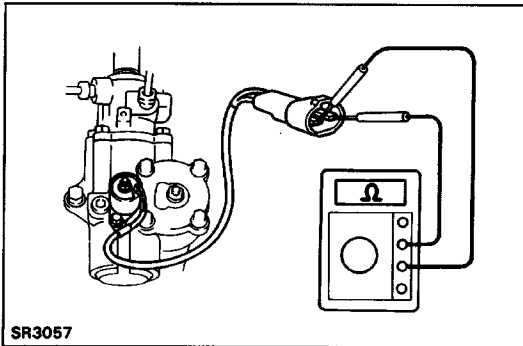

SR3057

### ON-VEHICLE INSPECTION

1. DISCONNECT WIRING CONNECTOR
2. MEASURE RESISTANCE

Measure the resistance between SOL - and SOL +.

Resistance: 6 - 11

3. CONNECT WIRING CONNECTOR

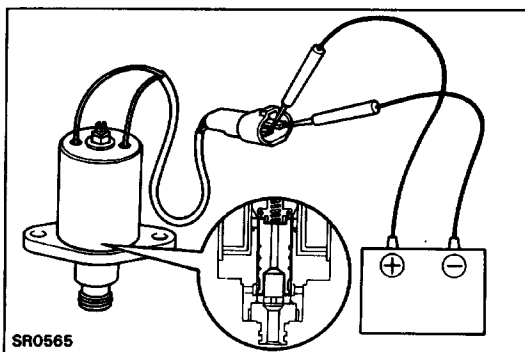

SR0565

### CHECK SOLENOID OPERATION

1. REMOVE SOLENOID VALVE FROM GEAR HOUSING
2. CHECK SOLENOID OPERATION

(a) Connect the battery positive terminal to the solenoid terminal SOL +.

(b) Connect the battery negative terminal to the solenoid terminal SOL -.

Confirm that the needle valve has withdrawn about 2 mm (0.79 in.).

If not, replace the solenoid valve.

3. INSTALL SOLENOID VALVE TO GEAR HOUSING

4. BLEEDING OF POWER STEERING LINE

## Power Steering ECU

### INSPECTION OF ECU

1. JACK UP VEHICLE AND SUPPORT IT ON STANDS
2. REMOVE CENTER CONSOLE

HINT: Do not disconnect the ECU connector.

### 3. START ENGINE

### 4. MEASURE VOLTAGE OF ECU

- (a) Using a voltmeter, measure the voltage between ECU terminals GND and SOL E) while the engine is idling.

Standard voltage: 0 – 0.05 V

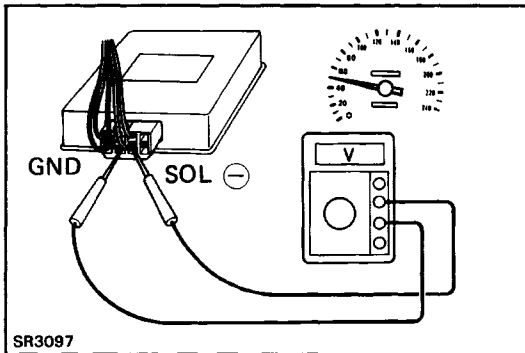
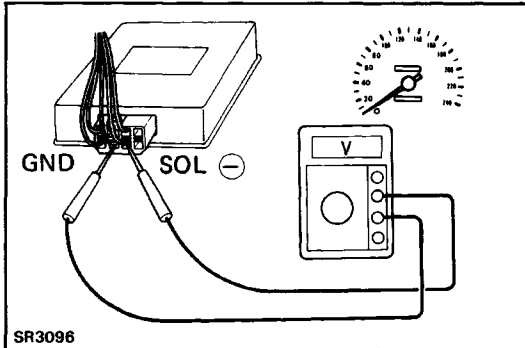

- (b) Place the transmission in gear and while running at about 50 km/h (31 mph), measure the voltage between the ECU terminals GND and SOL E).

Standard voltage: Voltage measured in (a) above, plus 0.12 – 0.24 V

If no voltage, try another ECU.

### 5. INSTALL CENTER CONSOLE

### 6. LOWER VEHICLE



# STEERING LINKAGE (2WD)

## REMOVAL AND INSTALLATION OF STEERING LINKAGE

Remove and install the parts as shown.

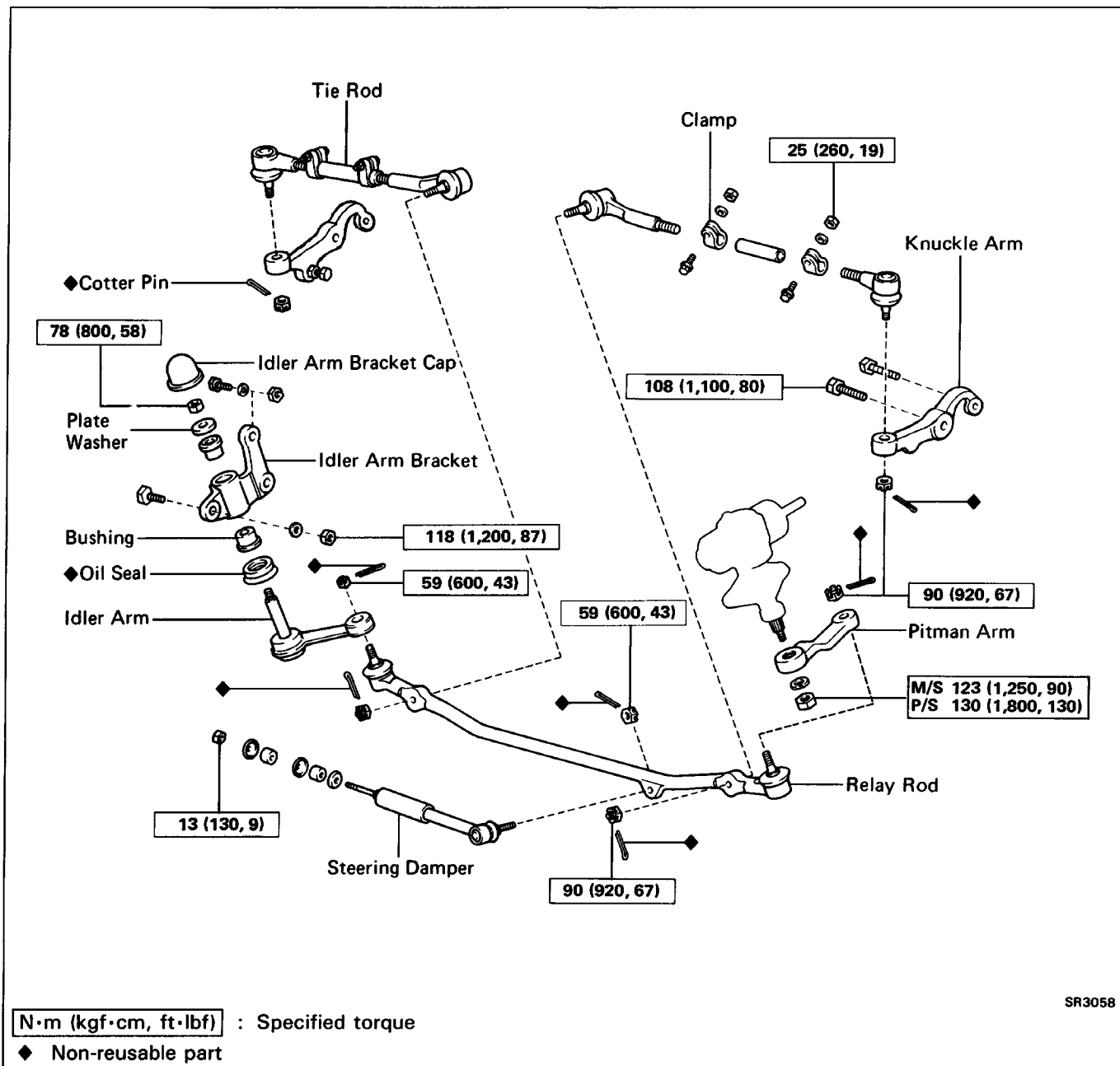

SR3058

**HINT:**

- When connecting the ball stud to the arm or rod, remove the grease on the joint surfaces.
- After torquing the ball stud nut to specified torque, advance the nut just enough to insert the cotter pin.
- After installing any of the steering linkage components, check the front wheel alignment. (See page SA-3, 6)

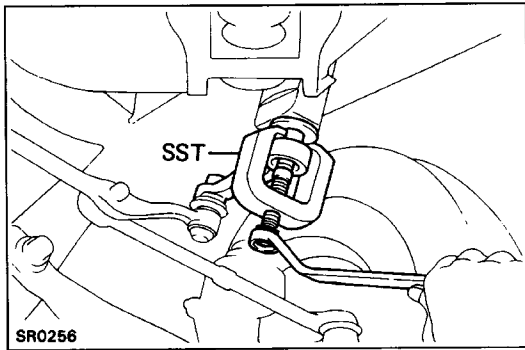

## (MAIN POINTS OF REMOVAL AND INSTALLATION)

### 1. DISCONNECT AND CONNECT PITMAN ARM FROM/TO SECTOR SHAFT

- (a) Loosen the pitman arm nut.
- (b) Using SST, disconnect the pitman arm from the sector shaft.  
SST 09610-55012
- (c) When connecting, align alignment marks on the pitman arm and the sector shaft, and install the spring washer and nut.

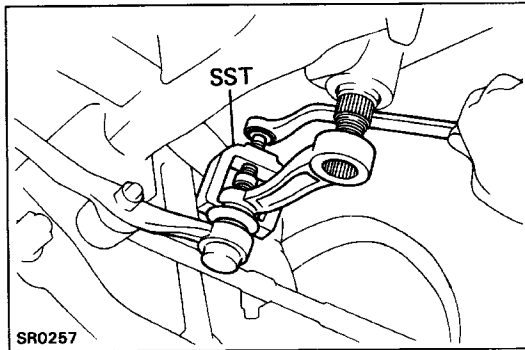
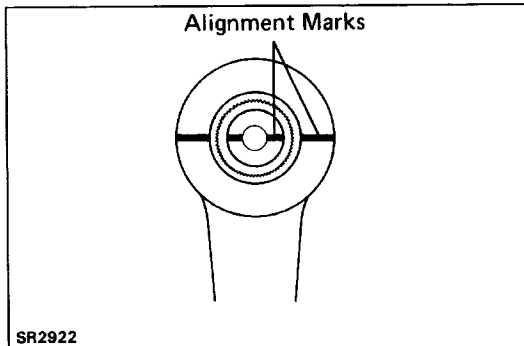

### 2. DISCONNECT PITMAN ARM FROM RELAY ROD

- Using SST, disconnect the pitman arm from the relay rod.  
SST 09611-22012

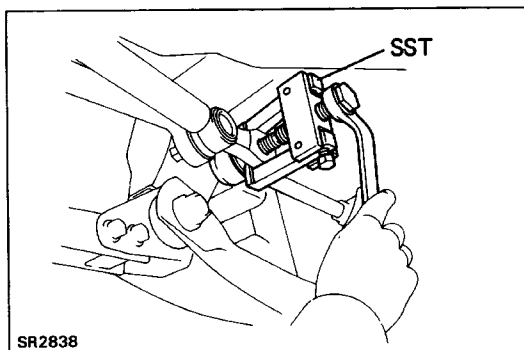

### 3. DISCONNECT TIE ROD FROM RELAY ROD

- Using SST, disconnect the tie rod from the relay rod.  
SST 09628-62011

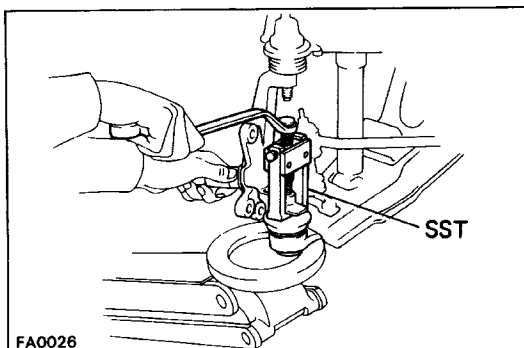

### 4. DISCONNECT TIE ROD FROM KNUCKLE ARM

- (a) Remove the front axle hub. (See page [SA-11](#))
- (b) Using SST, disconnect the tie rod from the knuckle arm.  
SST 09628-62011

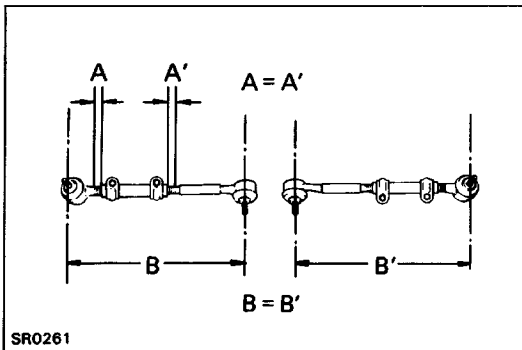

## 5. CONNECT TIE ROD

- (a) Screw the tie rod ends into the tie rod.

HINT: The tie rod length should be approximately 314.5 mm (12.382 in.), and the remaining length of threads on both tie rod ends should be equal.

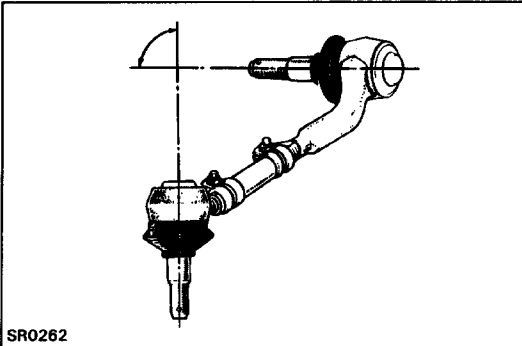

- (b) Turn the tie rods so that they cross at about 90 degrees. And connect it.

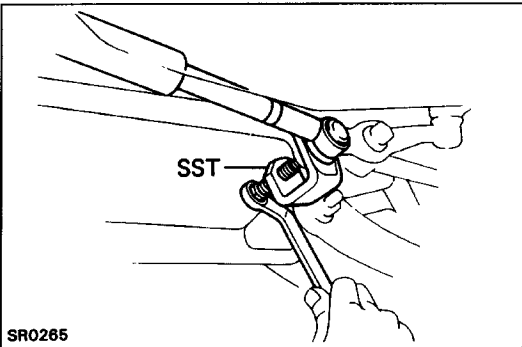

## 6. DISCONNECT STEERING DAMPER FROM RELAY ROD

Using SST, disconnect the steering damper from the relay rod.

SST 09611-12010

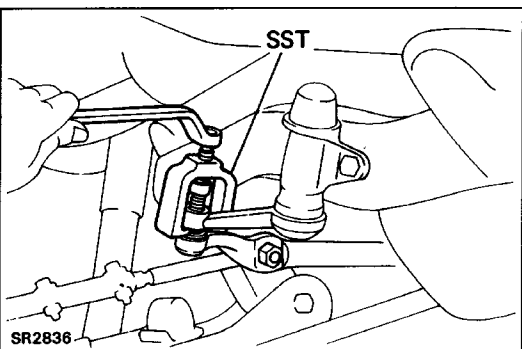

## 7. DISCONNECT IDLER ARM FROM RELAY ROD

Using SST, disconnect the idler arm from the relay rod.

SST 09611-22012

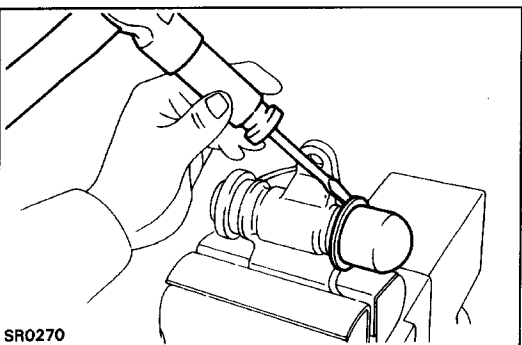

## DISASSEMBLY OF IDLER ARM BRACKET

### 1. REMOVE IDLER ARM BRACKET CAP

Using a screwdriver and hammer, remove the idler arm bracket cap.

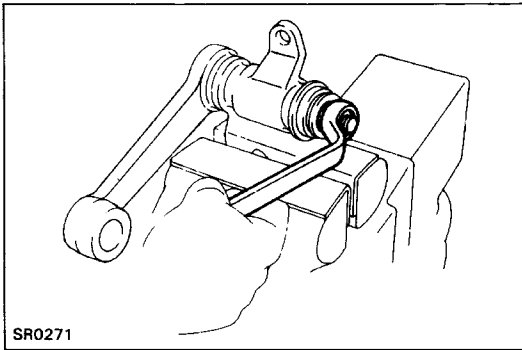

## 2. REMOVE IDLER ARM WITH SHAFT

Remove the nut and pull the idler arm with the shaft off the idler arm bracket.

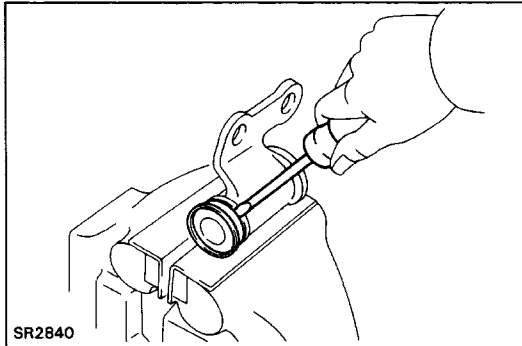

## 3. REMOVE OIL SEAL

Using a screwdriver, remove the oil seal.

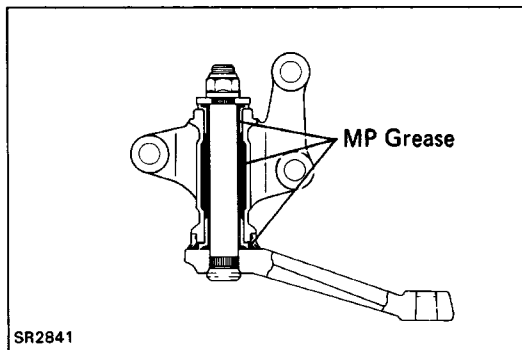

## ASSEMBLY OF IDLER ARM BRACKET

### 1. INSTALL NEW OIL SEAL

### 2. APPLY NIP GREASE

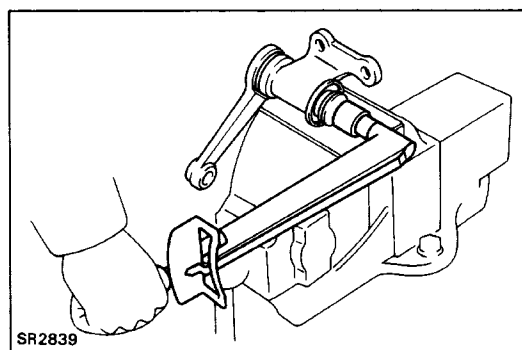

### 3. INSTALL IDLER ARM BRACKET

- Insert the idler arm shaft to the bracket.
- Install the washer and nut.

**Torque: 78 N-m (800 kgf-cm, 58 ft-lbf)**

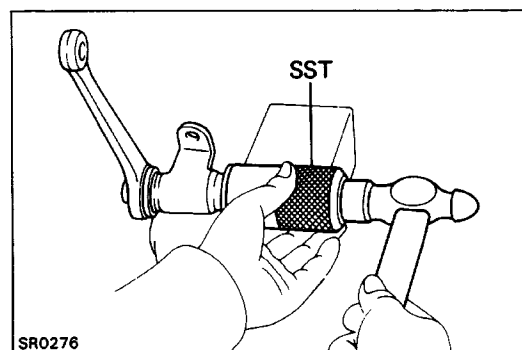

### 4. INSTALL IDLER ARM BRACKET CAP

- Apply sealant to the cap end.

**Sealant: Part No. 08826-00090, THREE BOND 1281 or equivalent**

- Using SST, install the idler arm bracket cap.

**SST 09636-20010**

# STEERING LINKAGE (4WD)

## REMOVAL AND INSTALLATION OF STEERING LINKAGE

Remove and install the parts as shown.

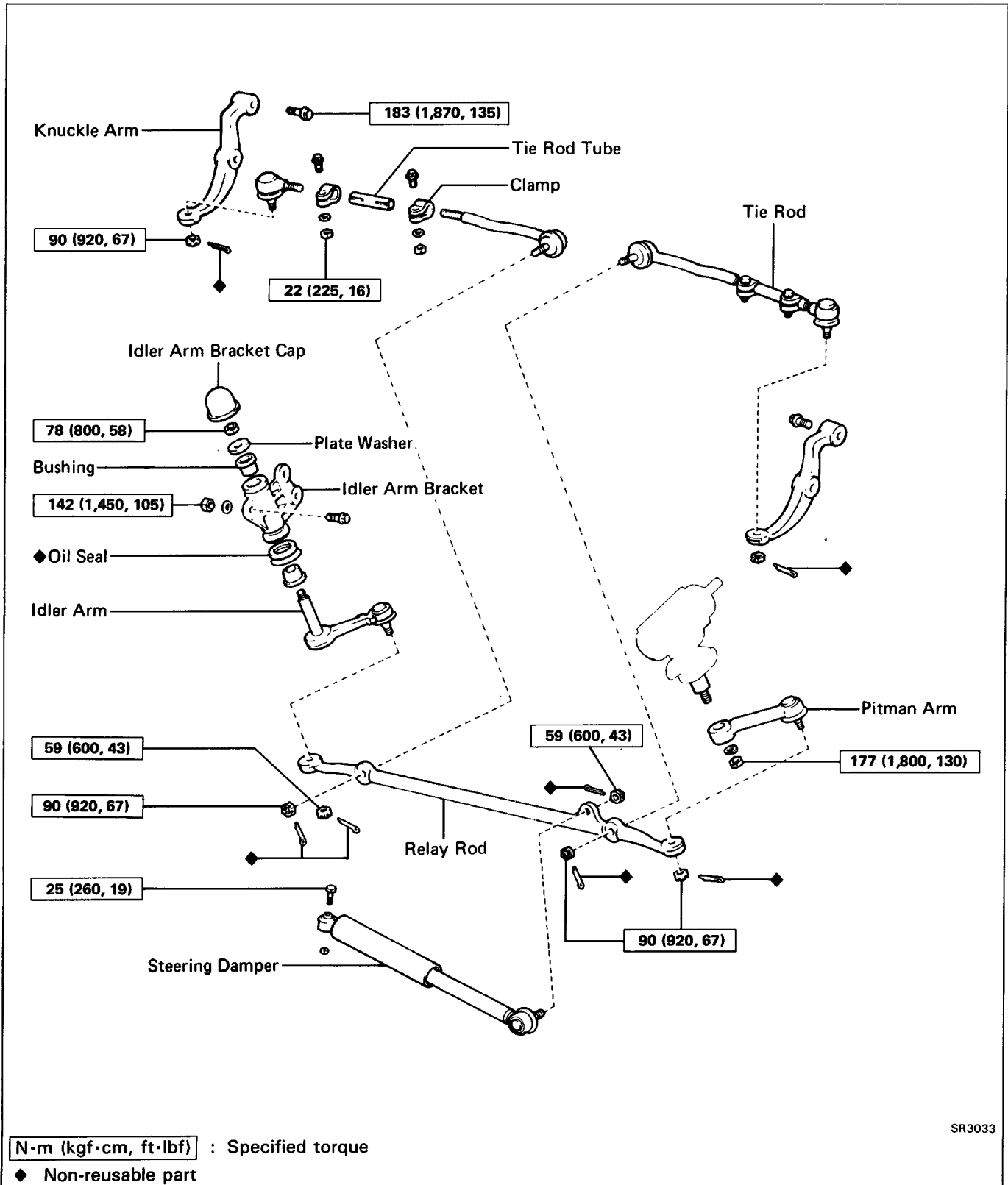

SR3033

HINT: (See page [SR-93](#))

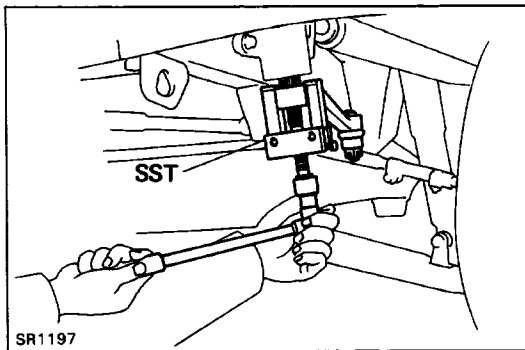

## (MAIN POINTS OF REMOVAL AND INSTALLATION)

### 1. DISCONNECT AND CONNECT PITMAN ARM FROM/TO SECTOR SHAFT

- (a) Loosen the pitman arm nut.
- (b) Using SST, disconnect the pitman arm from the sector shaft.  
SST 09628-62011

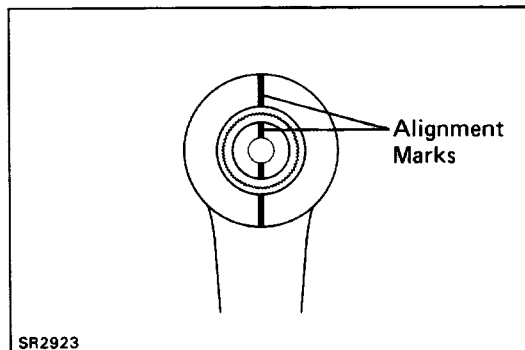

- (c) When connecting, align alignment marks on the pitman arm and the sector shaft, and install the spring washer and nut.

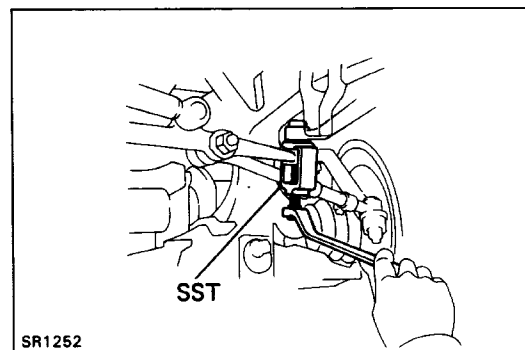

### 2. DISCONNECT PITMAN ARM FROM RELAY ROD

Using SST, disconnect the pitman arm from the relay rod.  
SST 09611-22012

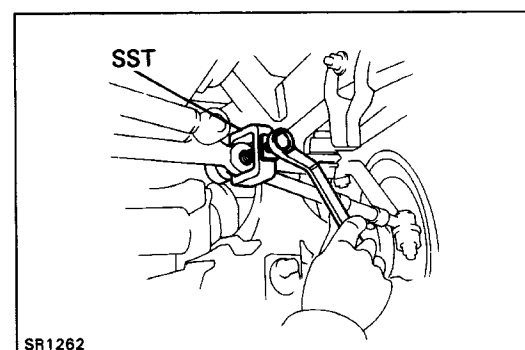

### 3. DISCONNECT TIE ROD FROM RELAY ROD

Using SST, disconnect the tie rod from the relay rod.  
SST 09611-22012

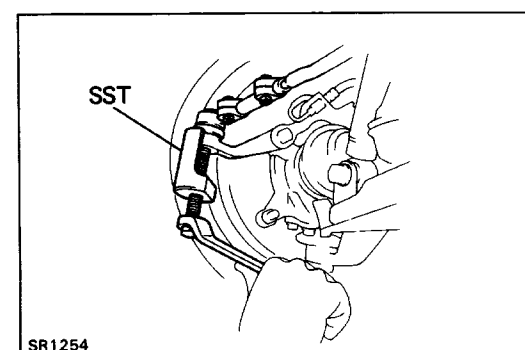

### 4. DISCONNECT TIE ROD FROM KNUCKLE ARM

Using SST, disconnect the tie rod from the knuckle arm.  
SST 09628-62011

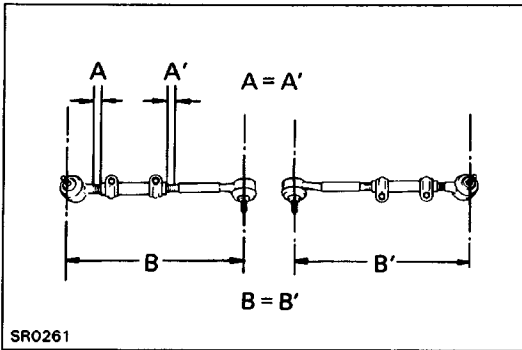

## 5. CONNECT TIE ROD

- (a) Screw the tie rod ends into the tie rod.

HINT: The tie rod length should be approximately 328.5 mm (12.933 in.), and the remaining length of threads on both tie rod ends should be equal.

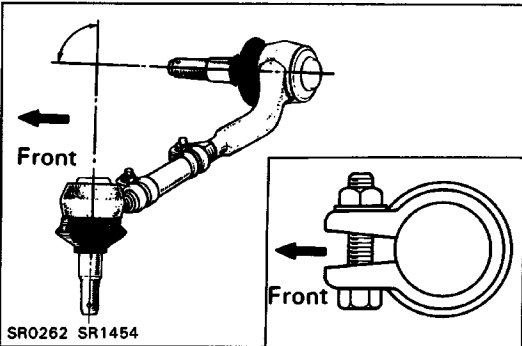

- (b) Turn the tie rods so that they cross at about 90 degrees. And connect it.

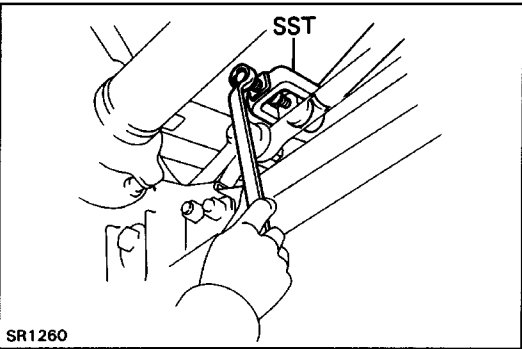

## 6. DISCONNECT STEERING DAMPER FROM RELAY ROD

Using SST, disconnect the steering damper from the relay rod.

SST 09611-22012

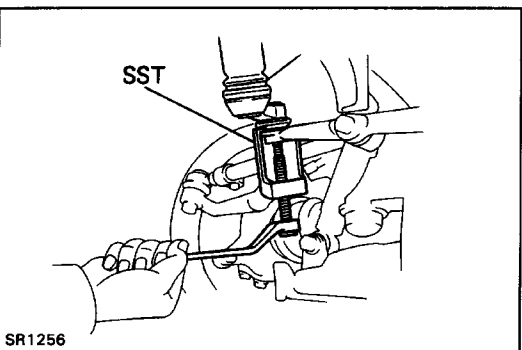

## 7. DISCONNECT IDLER ARM FROM RELAY ROD

Using SST, disconnect the idler arm from the relay rod.

SST 09610-20012

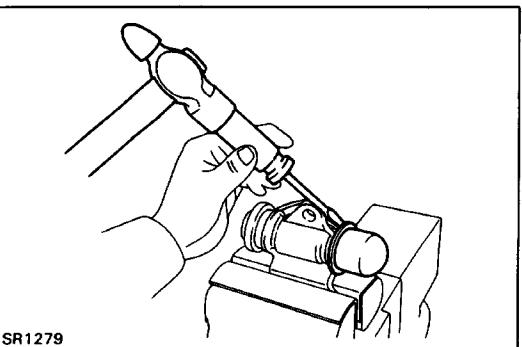

## DISASSEMBLY OF IDLER ARM BRACKET

### 1. REMOVE IDLER ARM BRACKET CAP

Using a screwdriver and hammer, remove the idler arm bracket cap.

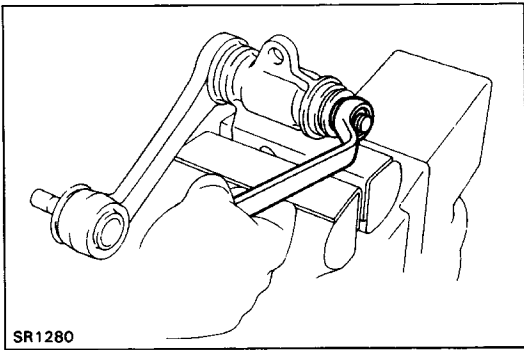

## 2. REMOVE IDLER ARM WITH SHAFT

Remove the nut and pull the idler arm with the shaft off the idler arm bracket.

## 3. REMOVE OIL SEAL

Using a screwdriver, remove the oil seal.

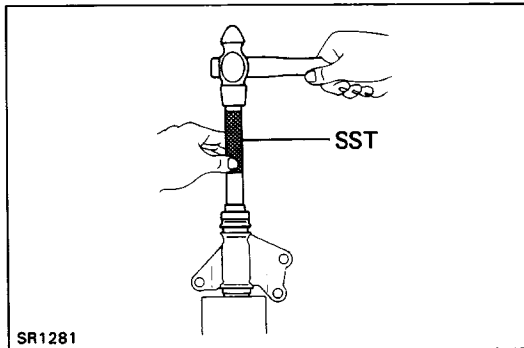

## ASSEMBLY OF IDLER ARM BRACKET

### 1. INSTALL OIL SEAL

Using SST, tap in a new oil seal.

SST 09620-30010 (09624-30010, 09631-00020)

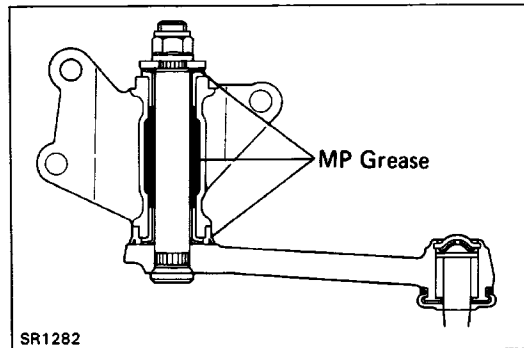

### 2. APPLY MP GREASE

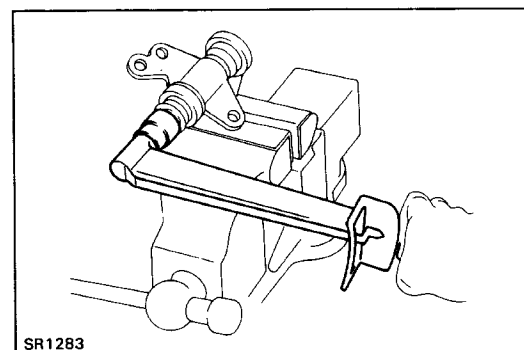

### 3. INSTALL IDLER ARM WITH SHAFT

- Install the idler arm shaft to the bracket.
- Install the washer and nut.

**Torque: 78 N·m (800 kgf·cm, 58 ft·lbf)**

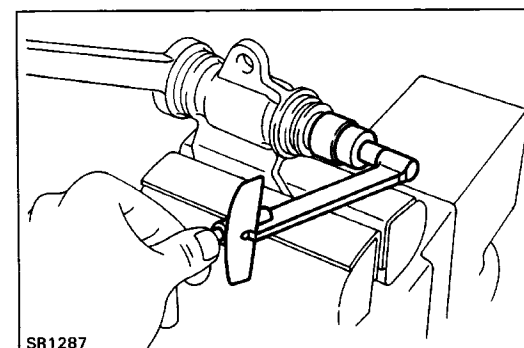

### 4. INSPECT IDLER ARM FOR ROTATION CONDITION

Using a torque meter, turn the nut several times and take the torque reading.

**Torque (Turning): 0.5 - 2.9 N·m**

**(5 - 30 kgf·cm, 5 - 26 in.·lbf)**

If necessary, replace the bushings.



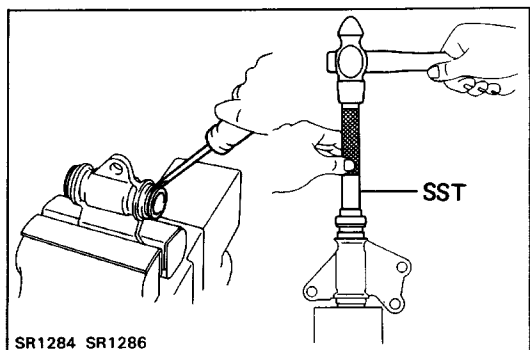

### 5. IF NECESSARY, REPLACE BUSHINGS

- (a) Using a screwdriver, remove the bushings.
- (b) Using SST, install each bushing to the idler arm bracket.  
SST 09620-30010 (09627-30010, 09631-00020)

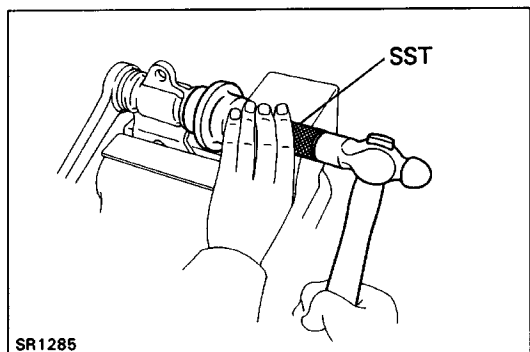

### 6. INSTALL IDLER ARM BRACKET CAP

- (a) Apply sealant to the cap end.  
**Sealant: Part No. 08826-00090, THREE BOND 1281 or equivalent**
- (b) Using SST, install the idler arm bracket cap.  
SST 09223-46011

# BODY ELECTRICAL SYSTEM

# GENERAL INFORMATION

Example:

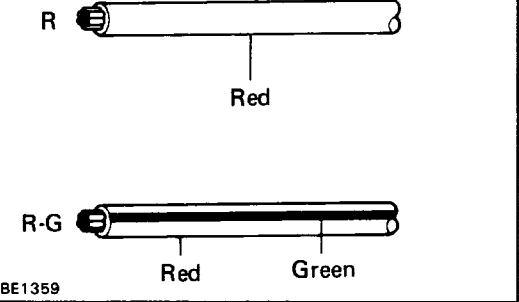

Wiring color code

Wire colors are indicated by an alphabetical code.

B = Black L = Blue R = Red

BR = Brown LG = Light Green V = Violet

G = Green O = Orange W = White

GR = Gray P = Pink \* = Yellow

The first letter indicates the basic wire color and the second letter indicates the color of the stripe.

## Connector

### 1. PIN NUMBER OF FEMALE CONNECTOR

Numbered in order from upper left to lower right.

### 2. PIN NUMBER OF MALE CONNECTOR

Numbered in order from upper right to lower left.

Example:

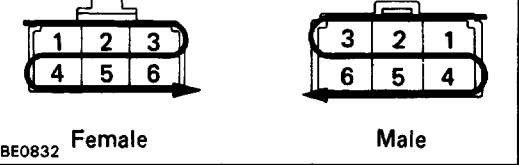

HINT: When connectors with different or the same number of terminals are used with the same parts, each connector name (letter of the alphabet) and pin number is specified.

Example:

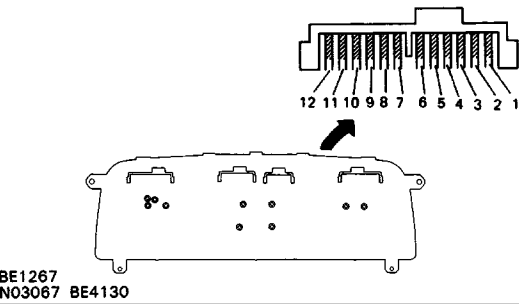

e.g. A7 = No. 7 pin of connector "A"

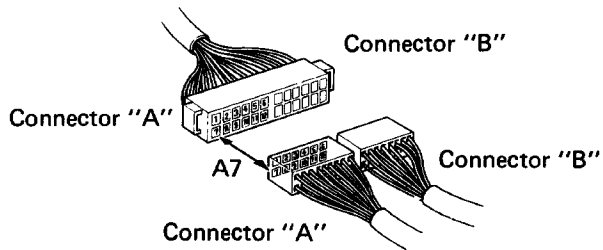

BE1267  
NO3067 BE4130

Example:

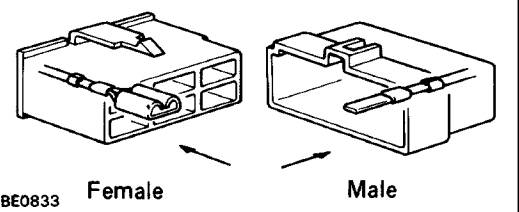

### 3. DISTINCTION OF MALE AND FEMALE CONNECTORS

Male and female connectors are distinguished by shape of their internal pins.

(a) All connectors are shown from the open end, and the lock is on top.

(b) To pull apart the connectors, pull on the connector itself, not the wires.

HINT: Check to see what kind of connector you are disconnecting before pulling apart.

Example:

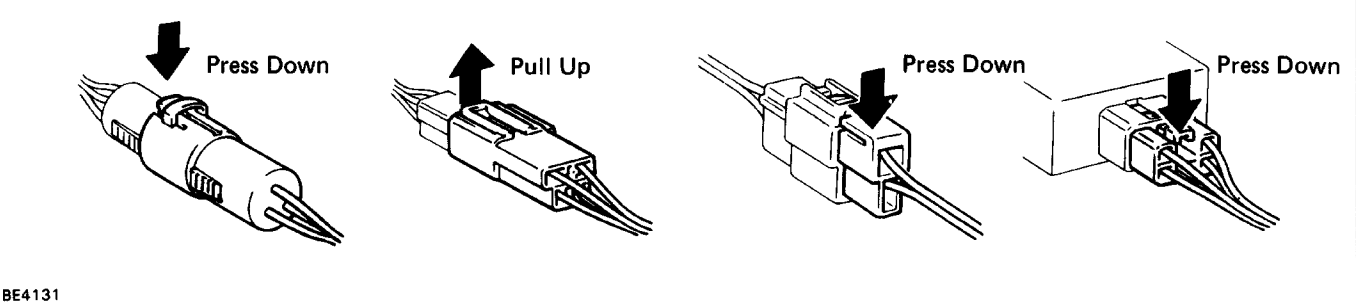

BE4131

## Replacement of High Current Fuse, Medium Current Fuse and Fuse

HINT: If replacing the fuse be sure to replace it with a fuse of fusible link with and equal amperage rating.

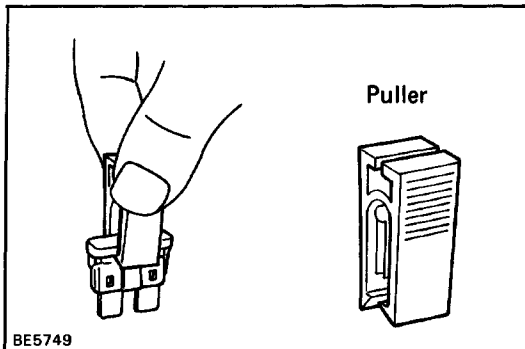
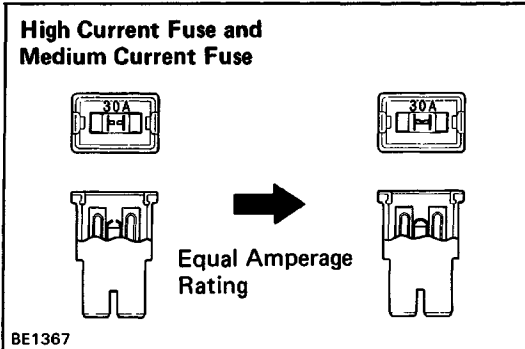
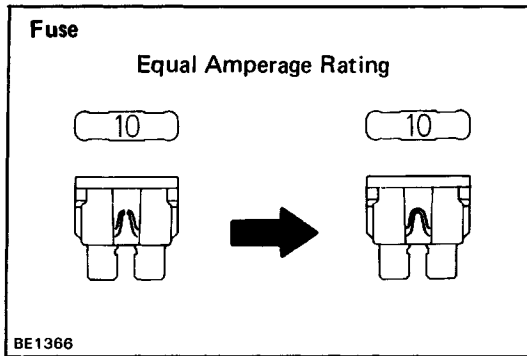

### NOTICE:

1. Turn off all electrical components and the ignition switch before replacing a fuse or fusible link. Do not exceed the fuse or fusible link amperage rating.
2. Always use a fuse puller for removing and inserting a fuse. Remove and insert straight in and out without twisting. Twisting could force open the terminals too much, resulting in a bad connection.

If a fuse or fusible link continues to blow, a short circuit is indicated. The system must be checked by a qualified technician.

### How to Inspect for System Inspection

This inspection procedure is a simple troubleshooting which should be carried out on the vehicle during system operation and was prepared on the assumption of system component troubles (except for the wires and connectors, etc. ).

Always inspect the trouble taking the following items into consideration.

- Ground point fault
- Open or short circuit of the wire harness
- Connector or terminal connection fault
- Fuse or fusible link fault

### NOTICE:

1. This is an on-vehicle inspection during system operations. Therefore, inspect the trouble with due regard for security.
2. In case of connecting the battery directly, be careful not to short circuit, and select the applicable voltage.

## Check for Voltage

- (a) Establish conditions in which voltage is present at the check point.  
Example:  
(A) Ignition switch on  
(B) Ignition switch and switch 1 (SW 1) on.  
(C) Ignition switch, switch 1 (SW 1) and relay on (switch 2 (SW2) off).
- (b) Using a voltmeter, connect the negative (-) lead to a good ground point or negative (-) battery terminal and the positive (+) lead to the connector or component terminal. This check can be done with a test bulb instead of a voltmeter.

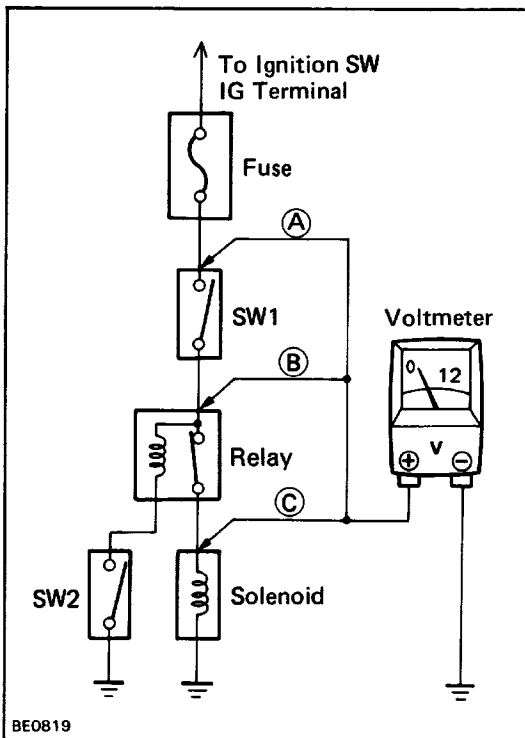

## Check for Continuity and Resistance

- (a) Disconnect the battery terminal or wire so there is no voltage between the check points.  
(b) Contact the two leads of an ohmmeter to each of the check points.

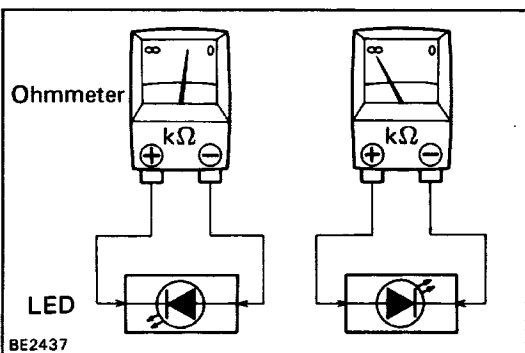
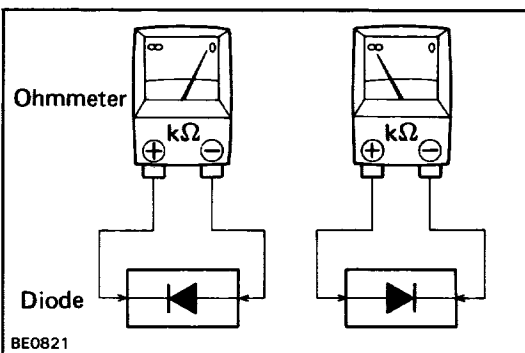
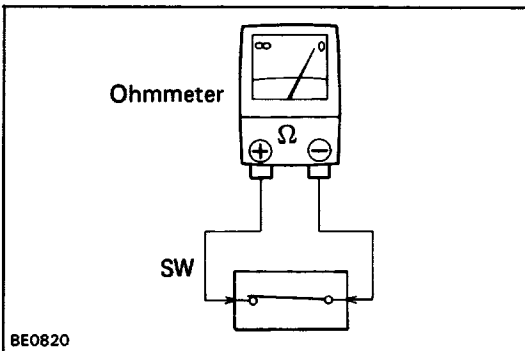

If the circuit has diodes, reverse the two leads and check again.

When contacting the negative (-) lead to the diode positive (+) side and the positive (+) lead to the negative (-) side, there should be continuity. When contacting the two leads in reverse, there should be no continuity.

HINT: Specifications may vary depending on the type of tester, so refer to the tester's instruction manual before performing the inspection.  
Check LED (Light Emitting Diode) in the same manner as that for diodes.

- Use a tester with a power source of 3 V or greater to overcome the circuit resistance.
- If a suitable tester is not available, apply battery positive voltage and check that the LED lights up.

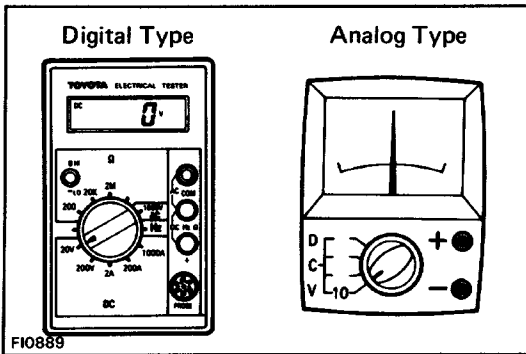

- (c) Use a volt/ohmmeter with high impedance (10 k/V minimum) for troubleshooting of the electrical circuit.

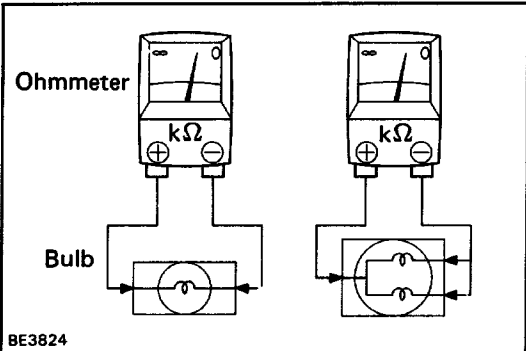

### Check the Bulb

- (a) Remove the bulb.
- (b) There should be continuity between the respective terminals of the bulb together with a certain amount of resistance.
- (c) Apply the two leads of the ohmmeter to each of the terminals.
- (d) Apply battery positive voltage and check that the bulb light up.

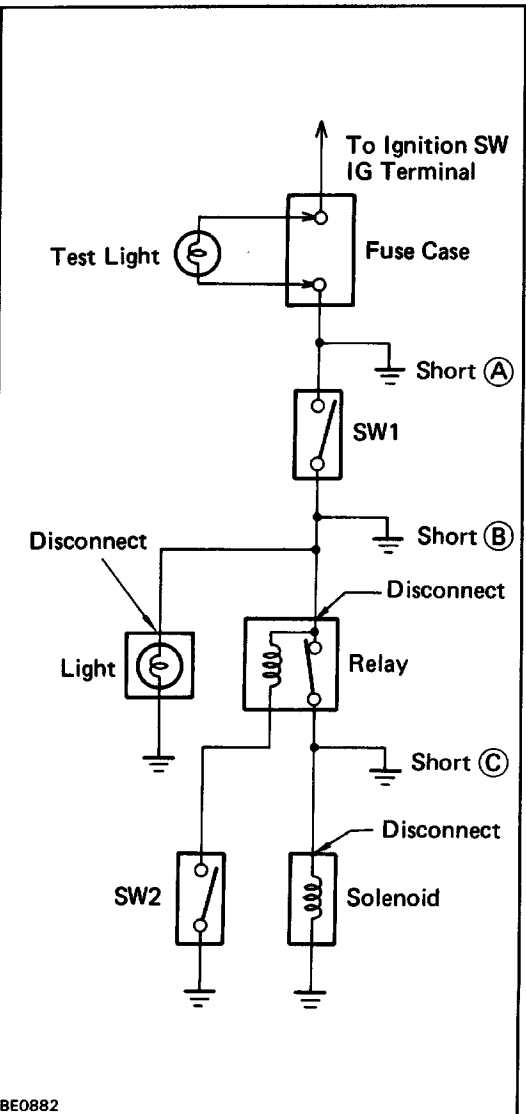

### Check for Short Circuit

- (a) Remove the blown fuse and eliminate all loads from the fuse.
- (b) Connect a test bulb in place of the fuse.
- (e) Establish conditions in which the test bulb comes on.
  - Example:
  - (A) Ignition switch on.
  - (B) Ignition switch and switch 1 (SW 1) on.
  - (C) Ignition switch, switch 1 (SW 1) and relay on (connect the relay) and switch 2 (SW2) off (or disconnect switch 2 (SW2)).
- (d) Disconnect and reconnect the connectors while watching the test bulb. The short lies between the connector where the test bulb stays lit and the connector where the bulb goes out.
- (e) Find the exact location of the short by lightly shaking the problem wire along the body.

# POWER SOURCE Parts Location

Junction Block No. 1

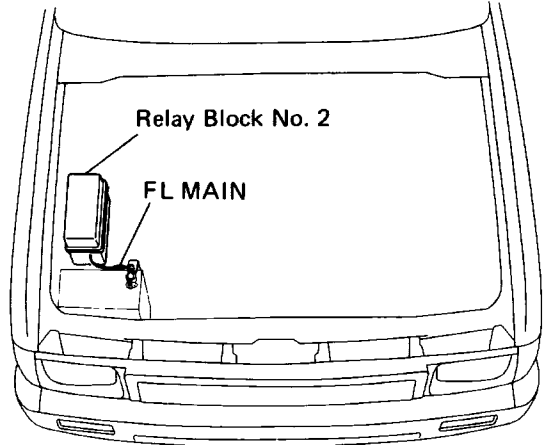
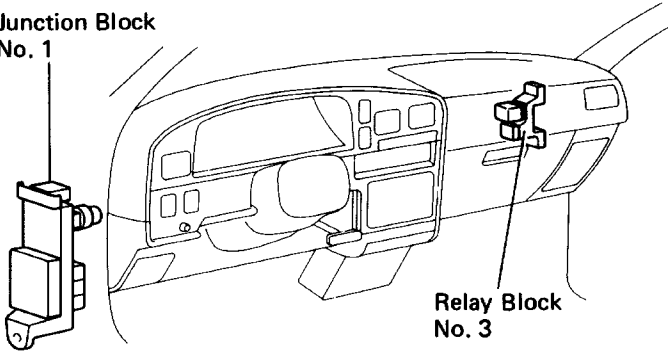

Junction Block No. 1

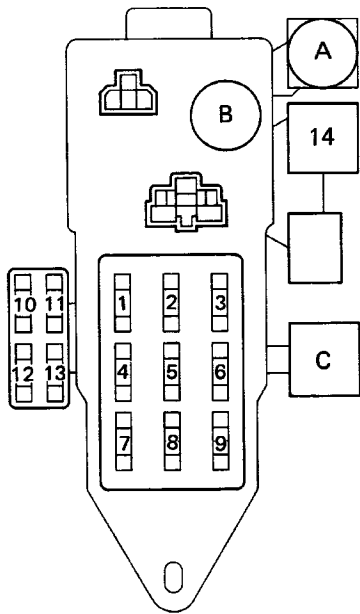

Fuses

1. ENGINE	10A
2. IGN	7.5A
3. TAIL	15A
4. WIPER	20A
5. GAUGE	10A
6. STOP	15A
7. RADIO	7.5A
8. CIG	15A
9. TURN	10A
10. REAR ANTILOCK	15A
11. -	-
12. ECM-IG	20A
13. -	-
14. POWER	30A

(w/ Power Door Lock and Power Window)

Relays

- A. Back Up Relay (USA)  
DRL Relay No. 4 (Canada)
- B. Taillight Control Relay
- C. Horn Relay
- 14. Back Up Relay (CANADA with column A/T)

Relay Block No. 2

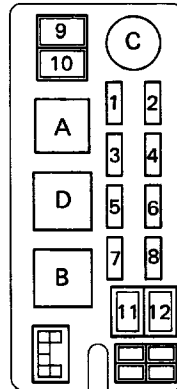

Fuses

1. CHARGE	7.5A
2. MFI	15A
3. HAZ-HORN	15A
4. DOME	15A
5. (USA) HEAD (RH)	10A
6. (USA) HEAD (LH)	10A
7. -	-
8. -	-
9. GEN (H-fuse)	80A
10. -	-
11. AM1 (H-fuse)	40A or 60A
12. AM2 (H-fuse) (CANADA)	30A

Relays

- 1. DRL 7.5A
- 5. HEAD LO (RH) 10A
- 6. HEAD LO (LH) 10A
- 7. HEAD HI (RH) 10A
- 8. HEAD HI (LH) 10A

Relays

- A. Headlight Dimmer Relay (CANADA)
- B. Headlight Control Relay
- C. MFI Relay
- D. Starter Relay

Relay Block No. 3

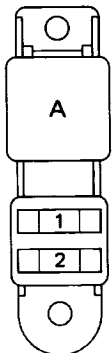

Fuses

1. A/C	10A
2. HEATER	30A

Relay

- A. Heater Relay

# Wiring Diagram

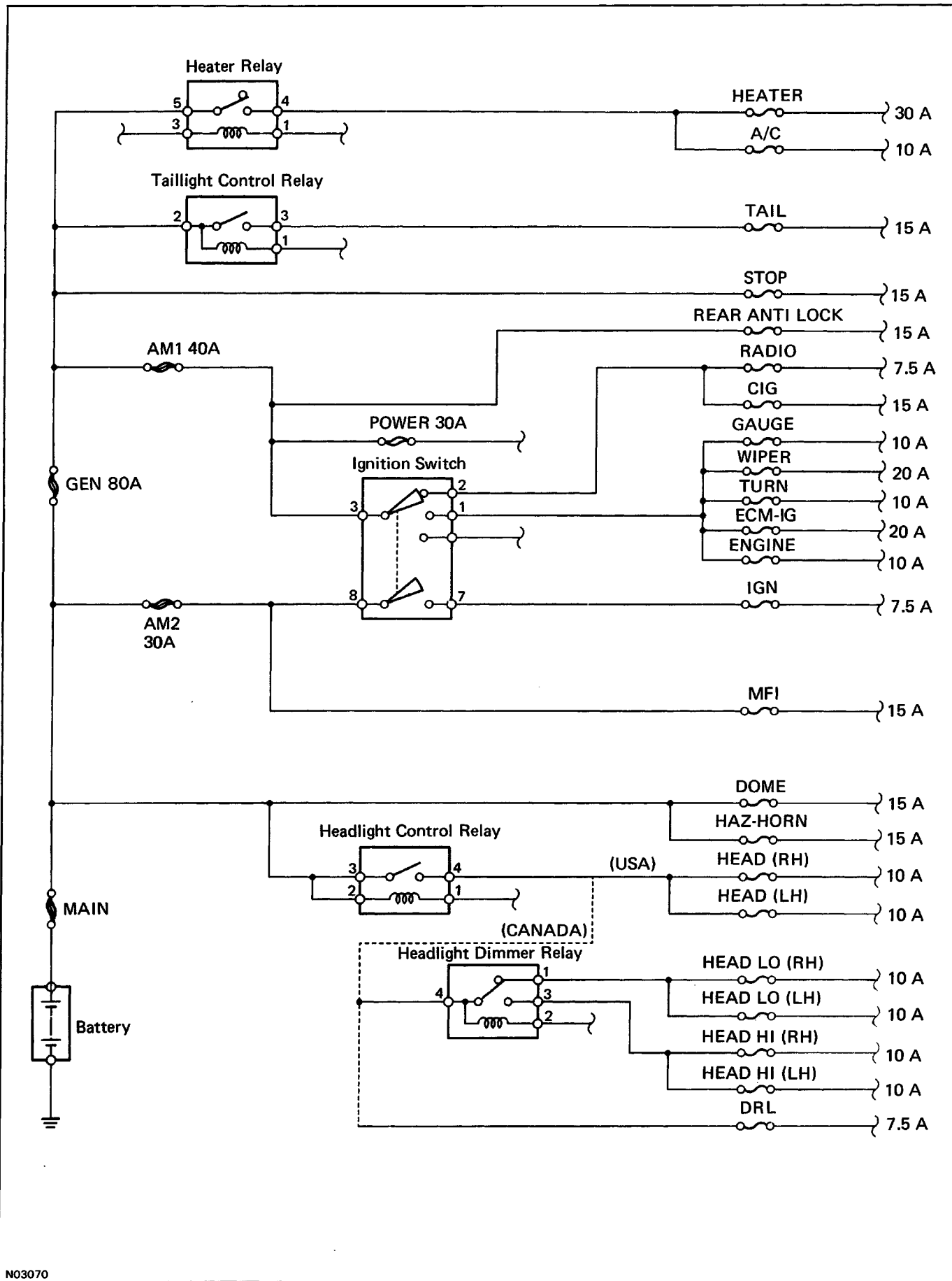



# IGNITION SWITCH Parts Location

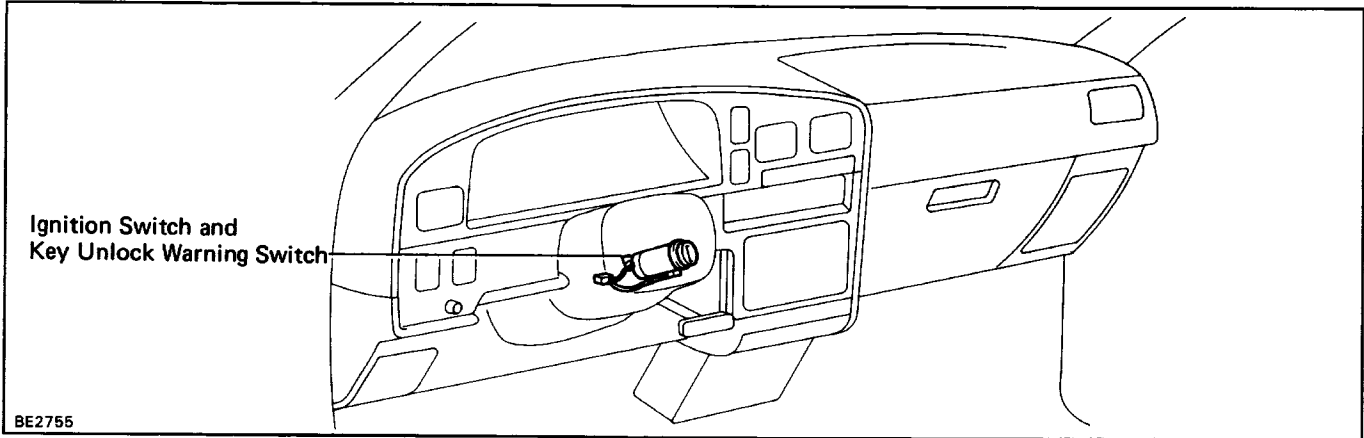

## Wiring and Connector Diagrams

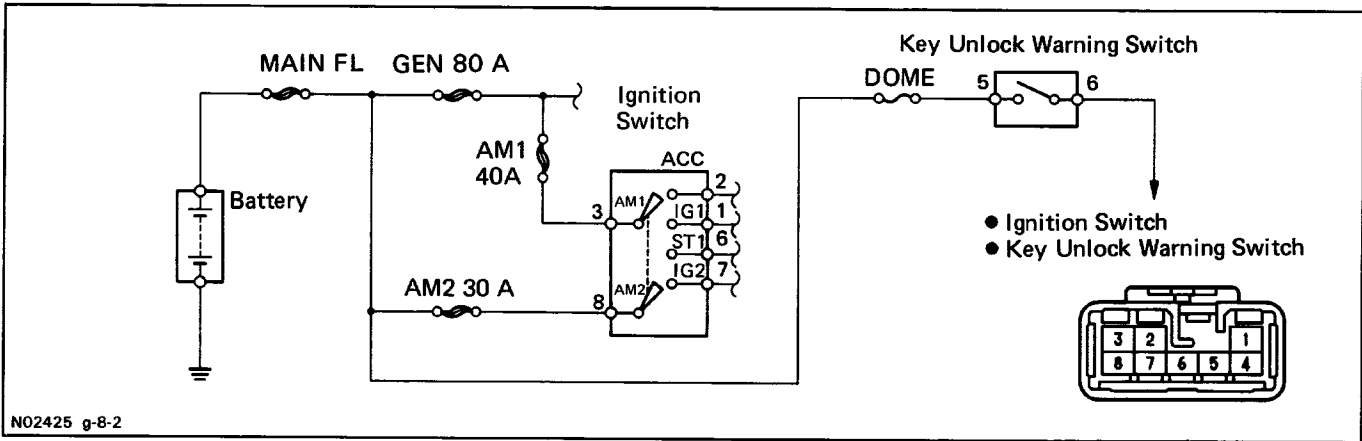

## Parts Inspection Ignition System INSPECT SWITCH (Ignition Switch /Continuity)

Terminal Switch position	1	2	3	6	7	8
LOCK						
ACC		○—○				
ON	○—○	○—○	○—○		○—○	○—○
START	○—○		○—○	○—○	○—○	○—○



BE0900 g-8-2

If continuity is not as specified, replace the switch.

# Key Confine Prevention System

## 1. INSPECT SWITCH

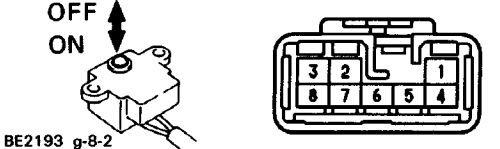
(Key Unlock Warning Switch/Continuity)

	Terminal		
	Switch position	3	4
	OFF (Key removed)		
ON (Key set)			

(Door Courtesy Switch/Continuity)

See step 2 on page [BE-42](#).

If continuity is not as specified, replace the switch.

## 2. INSPECT RELAY

See step 3 of Integration Relay on page [BE-42](#).

# LIGHTING SYSTEM

## Parts Location

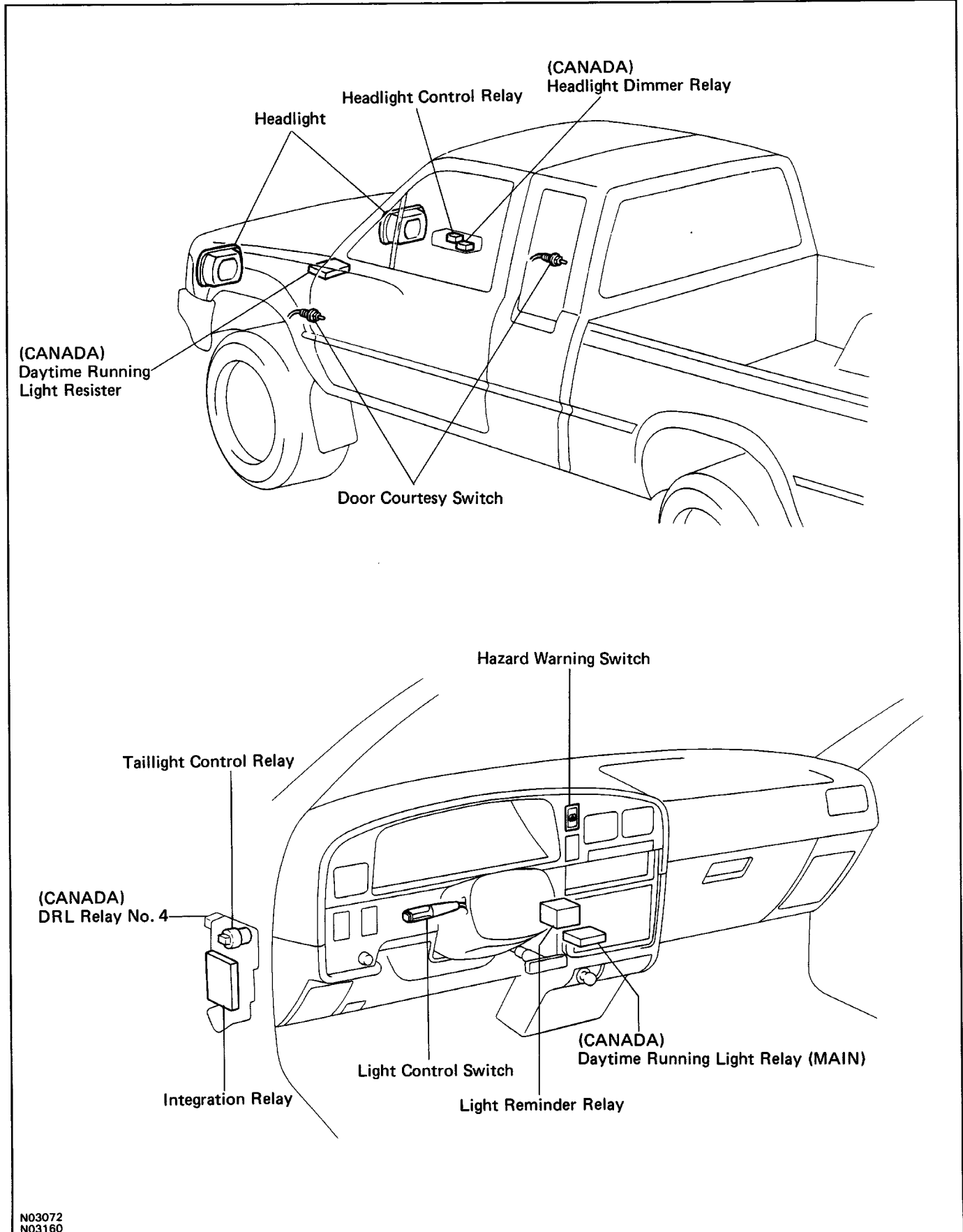

# Wiring and Connector Diagrams

- Headlight System (USA)
- Taillight System (USA)
- Lights-On Warning System
- Illuminated Entry System

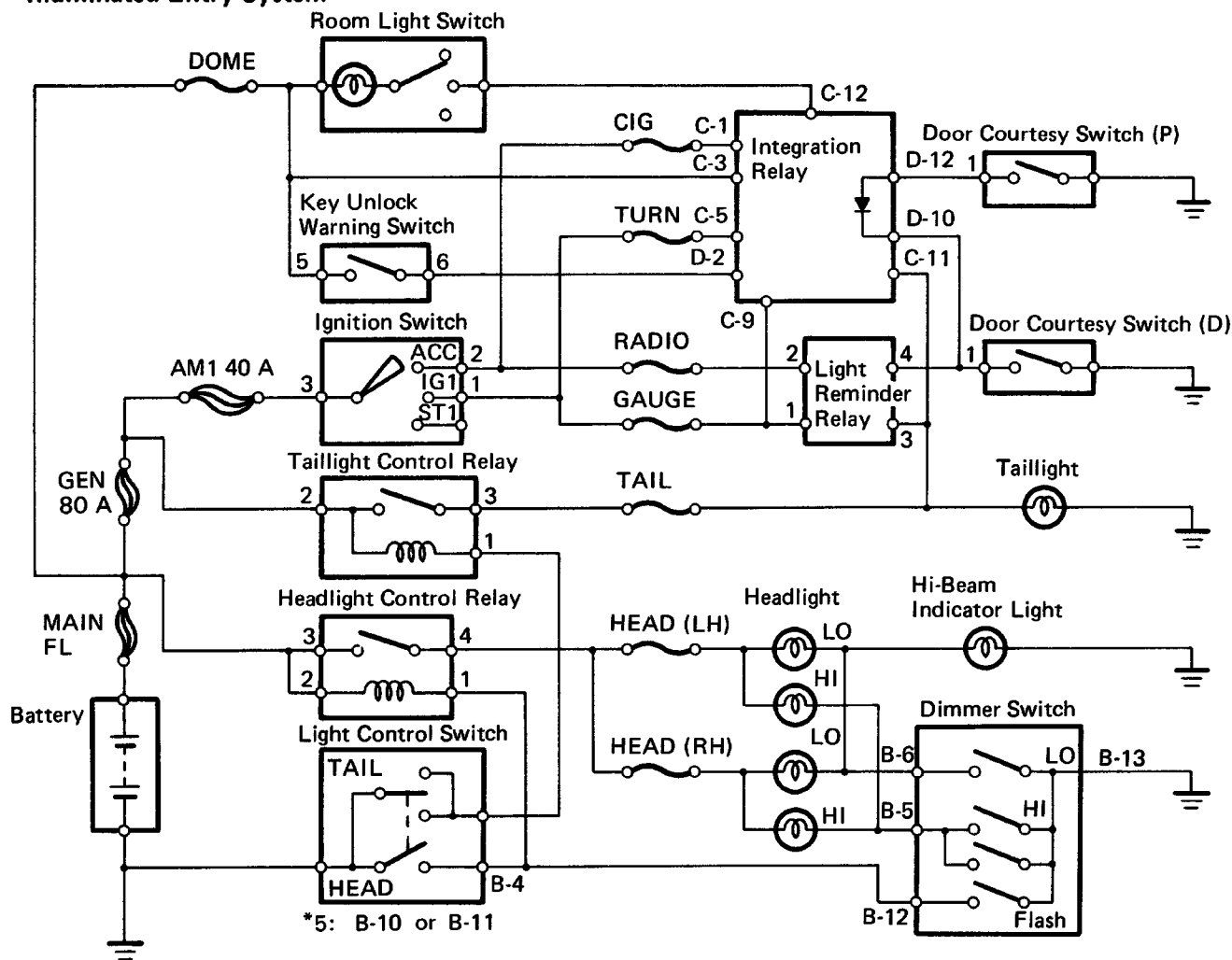

- Ignition Switch
- Key Unlock Warning Switch

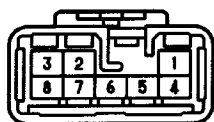

Taillight Control Relay

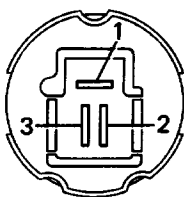

Headlight Control Relay

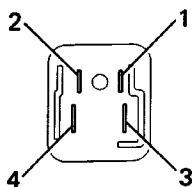

- Light Control Switch
- Dimmer Switch

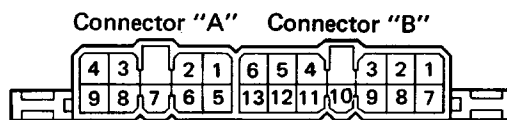

Integration Relay  
J/B Side: Connector "C"

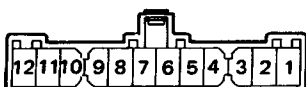

Wire Harness Side: Connector "D"

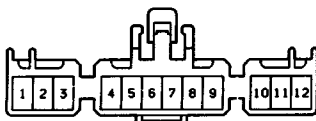

Light Reminder Relay



• Daytime Running Light System (CANADA)

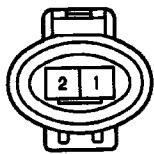
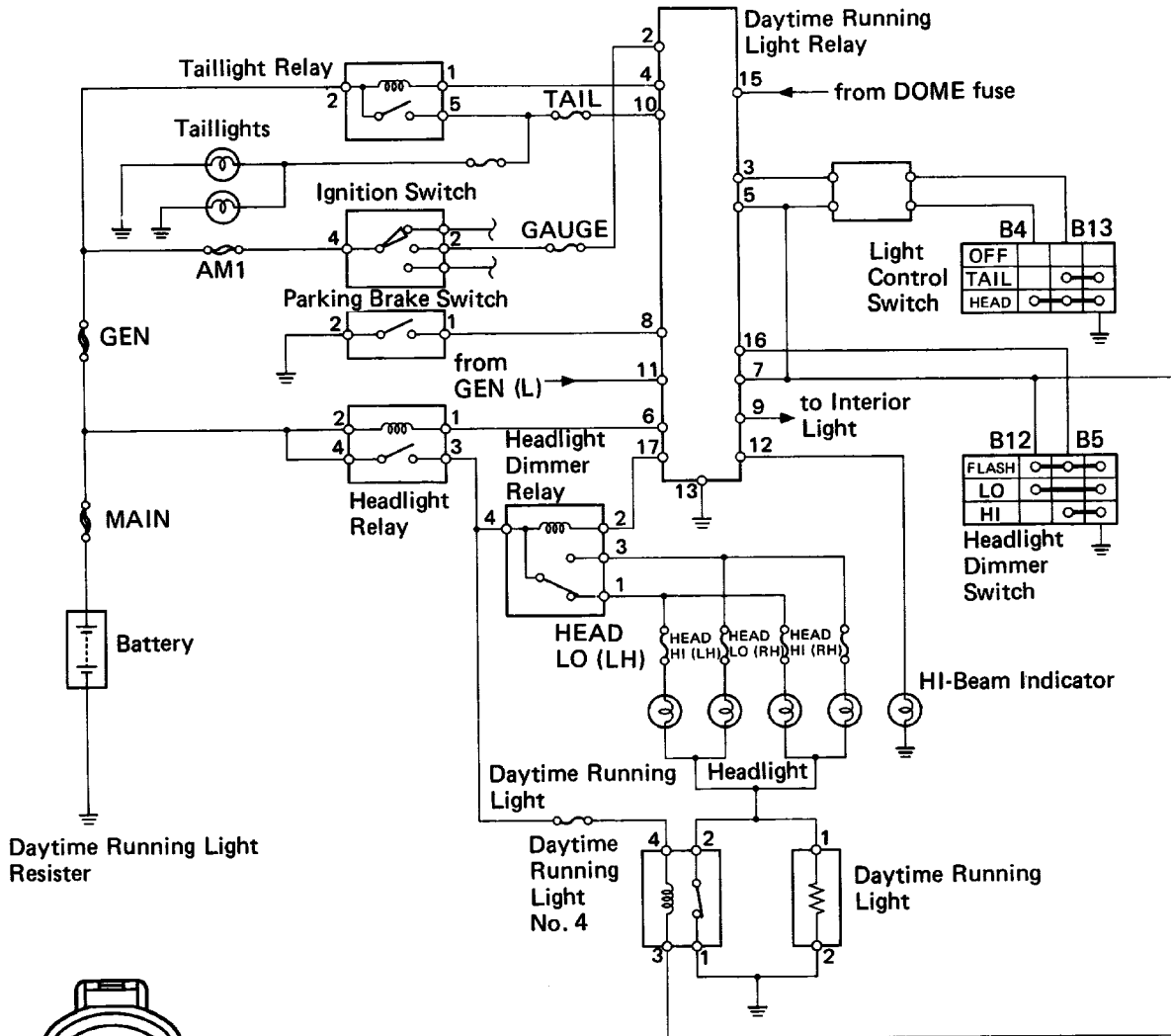

Daytime Running Light Relay

- Light Control Switch
- Headlight Dimmer Switch

Ignition Switch

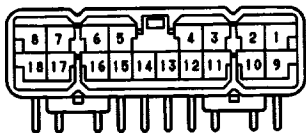

Daytime Running Light Relay and Headlight Control Relay

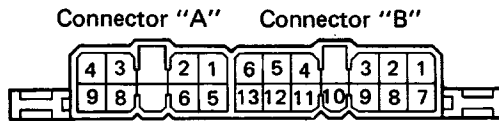

Taillight Control Relay

Headlight Dimmer Relay

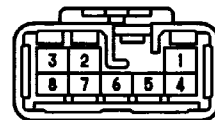

Parking Brake Switch

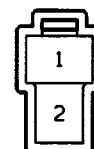
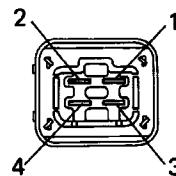
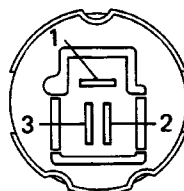
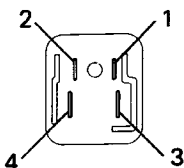

• Turn Signal and Hazard Warning System

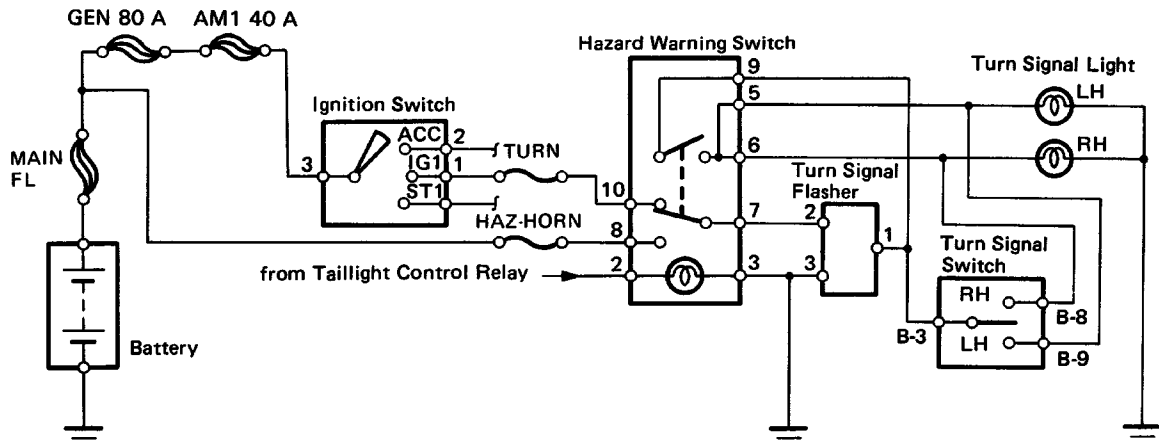

Ignition Switch

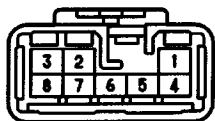

Hazard Warning Switch

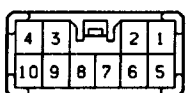

Turn Signal Flasher

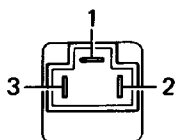

Turn Signal Switch

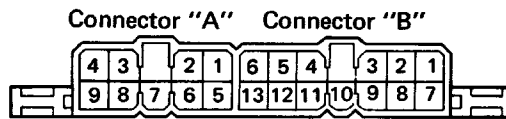

BE5629  
g-8-2 S-10-2 BE2896 BE0111

## Troubleshooting

Problem	Possible cause	Remedy	Page
Only one light does not light up	Light bulb burned out Socket, wire or ground faulty	Replace sealed beam headlight Repair as necessary	
Headlights do not light up	Fusible link blown Headlight control relay faulty Light control/dimmer switch faulty Daytime running light relay faulty Wiring and ground faulty	Replace fusible link Check relay Check switch Check relay circuit Repair as necessary	BE-1 9 BE-1 9 BE-20
High beam headlights or headlight flashers do not operate	Light control/dimmer switch faulty Daytime running light relay faulty Wiring or ground faulty	Check switch Check relay Repair as necessary	BE-1 9 BE-20
Tail, parking and license light do not light up	TAIL fuse blown  Fusible link blown Taillight control relay faulty Light control relay faulty Daytime running light relay faulty Wiring or ground faulty	Replace fuse and check for short Replace fusible link Check relay Check switch Check relay Repair as necessary	BE-3  BE-19 BE-1 9 BE-20
Stop lights do not light up	STOP fuse blown  Stop light switch faulty Wiring or ground faulty	Replace fuse and check for short Adjust or replace switch Repair as necessary	BE-3
Stop lights stay on	Stop light switch faulty	Adjust or replace switch	
Instrument lights do not light up (taillight light up)	Wiring or ground faulty	Repair as necessary	
Turn signal does not flash on one side	Turn signal switch faulty Wiring or ground faulty	Check switch Repair as necessary	BE-1 9

## Troubleshooting (Cont'd)

Problem	Possible cause	Remedy	Page
Turn signal do not operate	HAZ-HORN fuse blown  Turn signal flasher faulty Turn signal/hazard switch faulty Wiring or ground faulty	Replace fuse and check for short Check flasher Check switch Repair as necessary	BE-3  BE-23 BE-23
Hazard warning lights do not operate	HAZ-HORN fuse blown  Turn signal flasher faulty Turn signal/hazard switch faulty Wiring or ground faulty	Replace fuse and check for short Check flasher Check switch Repair as necessary	BE-3  BE-23 BE-23
Daytime running light system does not operate	DOME fuse blown  GAUGE fuse blown IG N fuse blown HEAD fuse blown TAIL fuse blown Headlight control relay faulty Taillight control relay faulty Dimmer relay faulty Ignition switch faulty Light control/dimmer switch faulty Wiring or ground faulty	Replace fuse and check for short           Check relay Check relay Check relay Check switch Check switch Repair as necessary	BE-3           BE-19 BE-19 BE-20 BE-8 BE-19



# Parts Adjustment

## Adjustment of Light Aiming

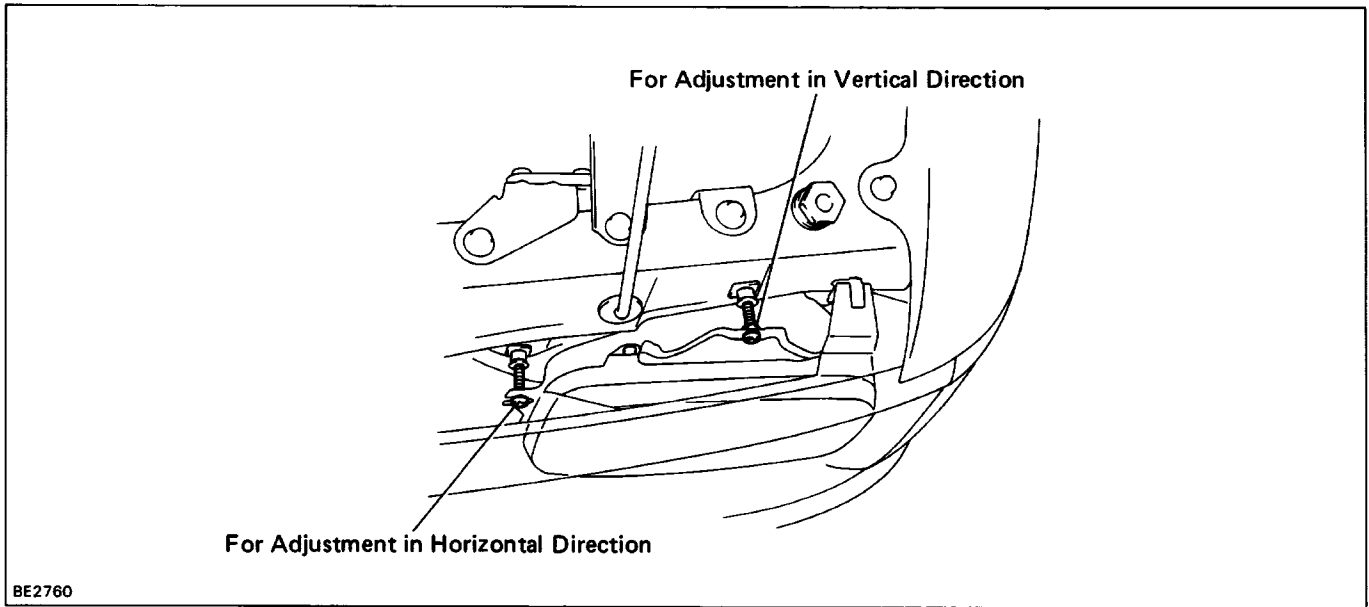

# Parts Replacement

## Components

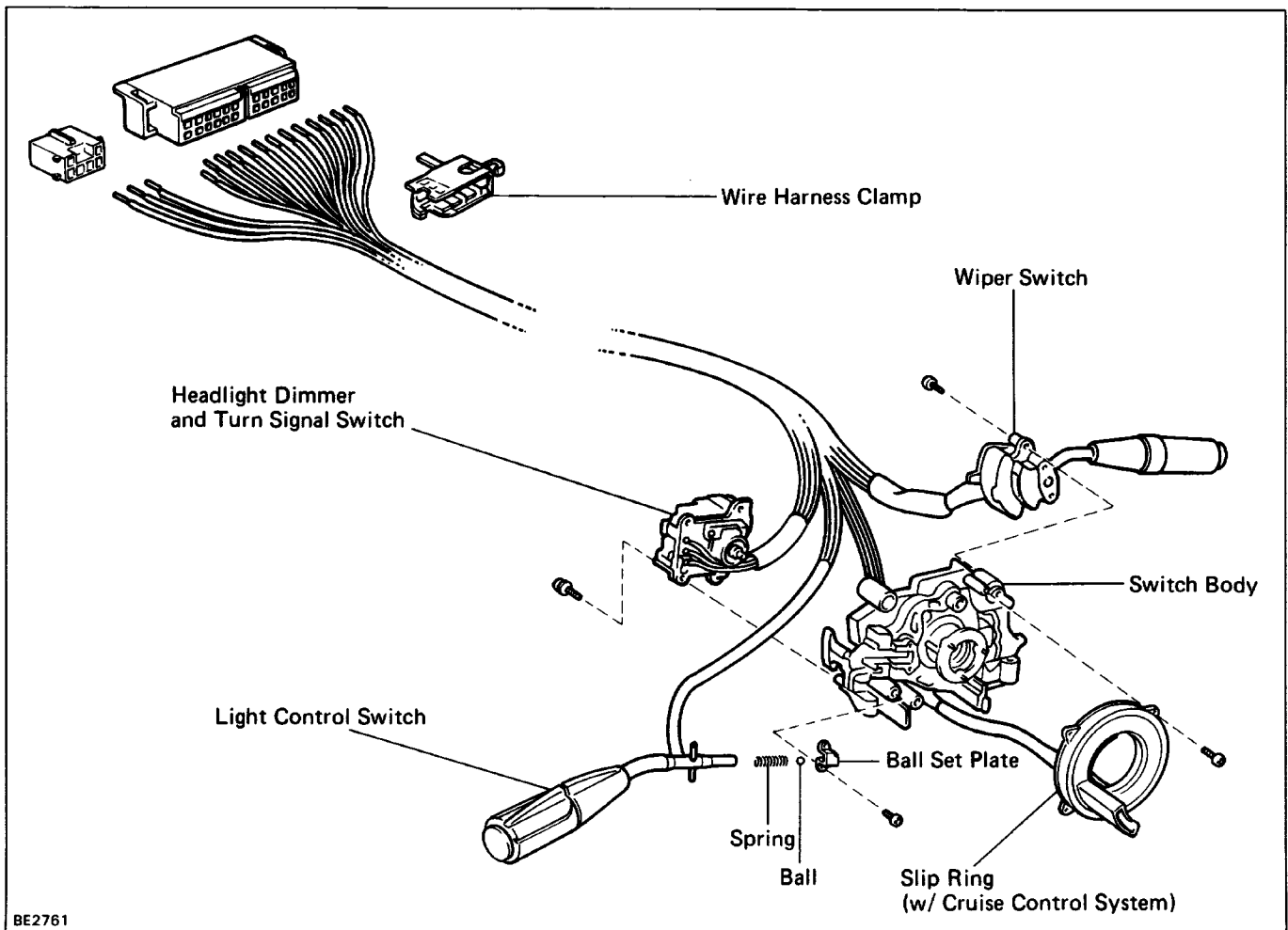

## Disassembly of Combination Switch

### NOTICE: w/ Cruise Control System

To prevent damage to the slip ring when removing the steering wheel, be careful of the following points.

- Keep the steering wheel in the "straight-ahead" steering position.
- Do not let the steering wheel strongly interfere with the connector part of the slip ring.

### 1. REMOVE WIRE HARNESS CLAMP FROM WIRE HARNESS

Pry loose— the two locking lugs and remove the clamp from the wire harness.

### 2. REMOVE TERMINALS FROM CONNECTOR

(a) Release four tabs and open the terminal cover.

(b) From the open end, insert a miniature screwdriver between the locking lug and terminal.

(c) Pry down the locking lug with the screwdriver and pull the terminal out from the rear.

### 3. (w/ Cruise Control System) REMOVE SLIP RING

Remove four screws and the slip ring from the switch body.

### 4. REMOVE LIGHT CONTROL SWITCH

(a) Remove two screws and the ball set plate from the switch body.

(b) Remove the ball and slide out the switch from the switch body with the spring.

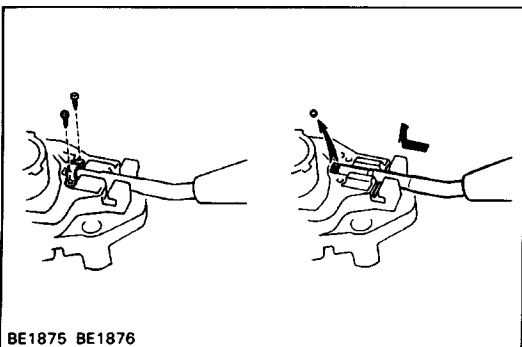
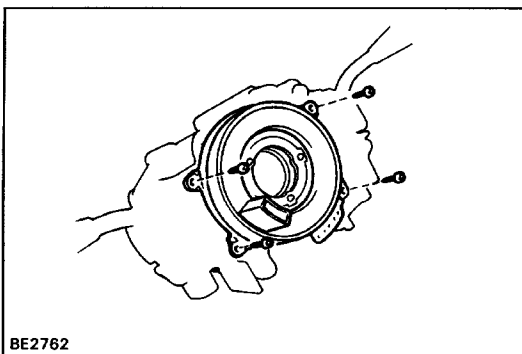
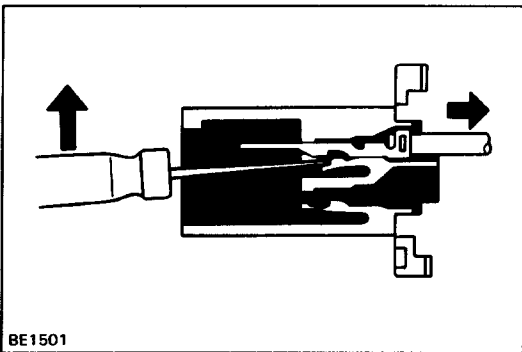
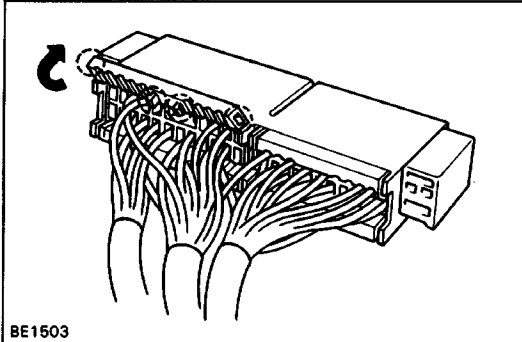

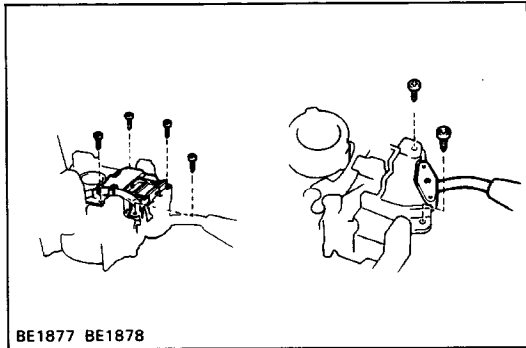

### 5. REMOVE HEADLIGHT DIMMER AND TURN SIGNAL SWITCH

Remove four screws and the switch from the switch body.

### 6. REMOVE WIPER AND WASHER SWITCH

Remove two screws and the switch from the switch body.

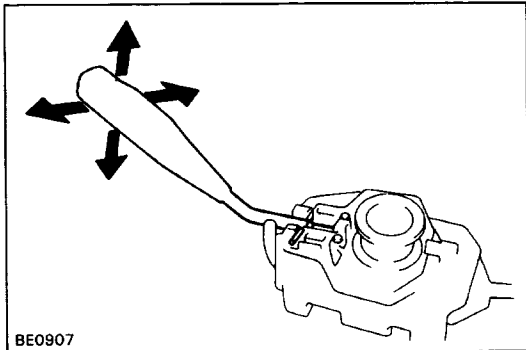

Assembly of Combination Switch

INSTALL PARTS OF COMBINATION SWITCH IN REVERSE SEQUENCE OF REMOVAL

HINT:

- After installing the light control switch to the switch body, insure that the switch operates smoothly.

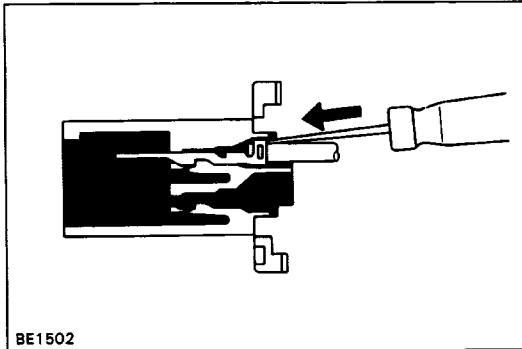

- Push in the terminal until it is securely locked in the connector lug.

# Parts Inspection

## Headlight, Taillight and Daytime Running Light System

### 1. INSPECT COMBINATION SWITCH (Light Control Switch /Continuity)

Reference:

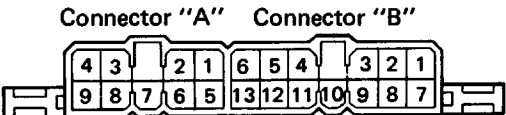
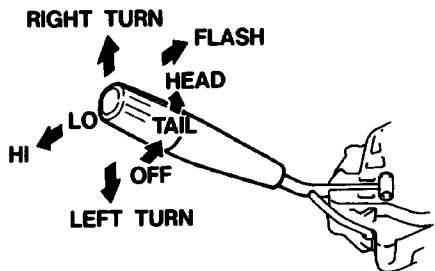

BE2414  
BE0111

Terminal (Color) Switch position	B-10 (W)	B-11 (W)	B-4 (R)
OFF			
TAIL	○	○	
HEAD	○	○	○

### (Headlight Dimmer and Turn Signal Switch/Continuity) Headlight Dimmer Switch

Terminal (Color) Switch position	B-5 (R-Y)	B-6 (R-G)	B-12 (R-W)	B-13 (W-B)
Flash	○		○	○
Low beam		○		○
High beam	○			○

### Turn Signal Switch

Terminal (Color) Switch position	B-3 (G-W)	B-8 (G-Y)	B-9 (G-B)
Left turn	○		○
Neutral			
Right turn	○	○	

If continuity is not as specified, replace the switch.

### 2. INSPECT RELAY

#### (Headlight Control Relay/Continuity)

BE1838 BE1840

Terminal Condition	1	2	3	4
Constant	○	○		
Apply battery positive voltage to terminals 1 and 2.			○	○

#### (Taillight Control Relay/Continuity)

BE2763 BE2505

Terminal Condition	1	2	3
Constant	○	○	
Apply battery positive voltage to terminals 1 and 2.		○	○

If continuity is not as specified, replace the relay.

(Headlight Dimmer Relay/Continuity)

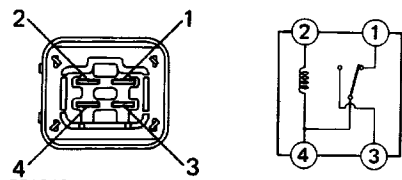

Terminal	1	2	3	4
Condition				
Constant	○	○	○	○
Apply battery positive voltage to terminals 2 and 4.			○	○

If continuity is not as specified, replace the relay.

Wire Harness Side



e-18-1

**1. INSPECT DAYTIME RUNNING LIGHT RELAY**  
(Relay Circuit)

Disconnect the connector from the relay and inspect the connector on the wire harness side as shown in the chart.

Check for	Tester connection	Condition	Specified value	
Continuity	3 - Ground	Light control switch position	OFF TAIL or HEAD	No continuity Continuity
		5 - Ground	Light control switch position	OFF or TAIL HEAD
	7 - Ground		Headlight dimmer switch position	Low beam or High beam Flash
		8 - Ground		Parking brake switch position
	13 - Ground		Constant	
	16 - Ground	Headlight dimmer switch position	Low beam High beam or Flash	No continuity Continuity
			Voltage	2 - Ground 18 - Ground
4 - Ground 6 - Ground 15 - Ground	Constant			
		11 - Ground		Engine

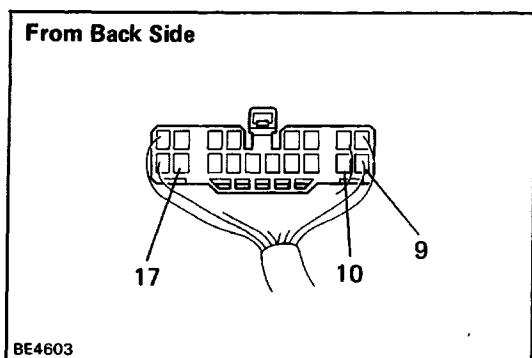

(Relay Circuit/Connector connected)

Connect the wire harness side connector to the relay and inspect wire harness side connector from the back side as shown.

Check for	Tester connection	Condition		Specified value
Voltage	<b>9 – Ground</b>	Light control switch position	OFF	No voltage
			TAIL or HEAD	Battery positive voltage
	<b>10 – Ground</b>	Light control switch position	OFF	No voltage
			TAIL or HEAD	Battery positive voltage
	<b>17 – Ground</b>	Headlight dimmer switch position	Low beam or High beam	No voltage
			Flash	Battery positive voltage

If circuit is as specified, replace the relay.

#### 4. INSPECT PARKING BRAKE SWITCH

(See page [BE-39](#))

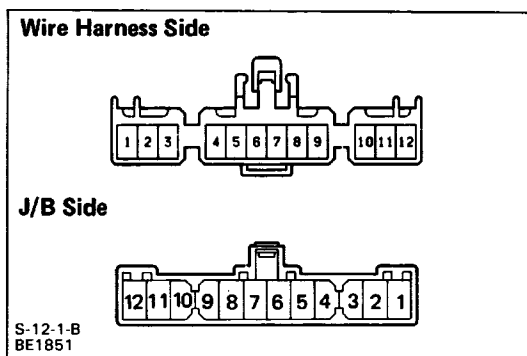
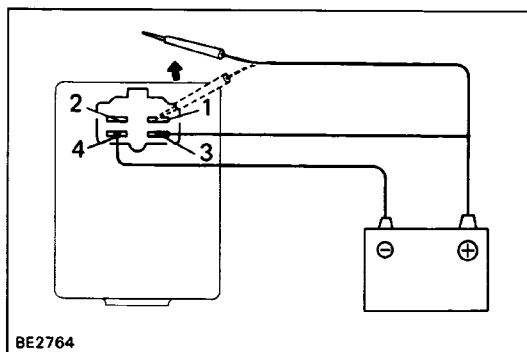
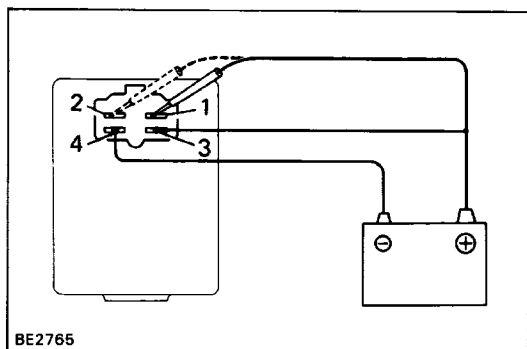

## Lights-On Warning System

### 1. INSPECT DOOR COURTESY SWITCH

See combination meter on page [BE-39](#).

### 2. INSPECT LIGHT REMAINDER RELAY

#### (Relay Circuit/Operation)

- Connect the positive (+) lead from the battery to terminal 3 and the negative (-) lead to terminal 4.
  - Check that the buzzer does not sound when connected terminal 1 or 2 to the positive (+) lead.
  - Check that the buzzer sounds when disconnecting terminal 1 or 2 from the positive (+) lead.
- If operation is not as specified, replace the relay.

## Illuminated Entry System

### 1. INSPECT DRIVER'S DOOR COURTESY SWITCH

See combination meter on page [BE-40](#).

### 2. INSPECT INTEGRATION RELAY

#### (Relay Circuit)

Disconnect the connectors from the relay and inspect the connectors on the wire harness side and JIB side as shown in the chart.

(Wire Harness Side)

Check for	Tester connection	Condition		Specified value
Continuity	4 - Ground	Constant		Continuity
	7 - Ground	Constant		Continuity
	10 - Ground	Driver's door position	Closed (Courtesy switch OFF)	No continuity
Opened (Courtesy switch ON)			Continuity	

(JIB Side)

Check for	Tester connection	Condition		Specified value
Continuity	7 - Ground	Constant		Continuity
Voltage	3 - Ground	Constant		Battery positive voltage
	12 - Ground	Constant		Battery positive voltage

If the circuit is as specified, replace the relay.

## Turn Signal and Hazard Warning System

### 1. INSPECT SWITCHES

(Turn Signal Switch /Continuity)

See Headlight Dimmer and Turn Signal Switch on page  
BE-1 9.

#### (Hazard Warning Switch/Continuity)

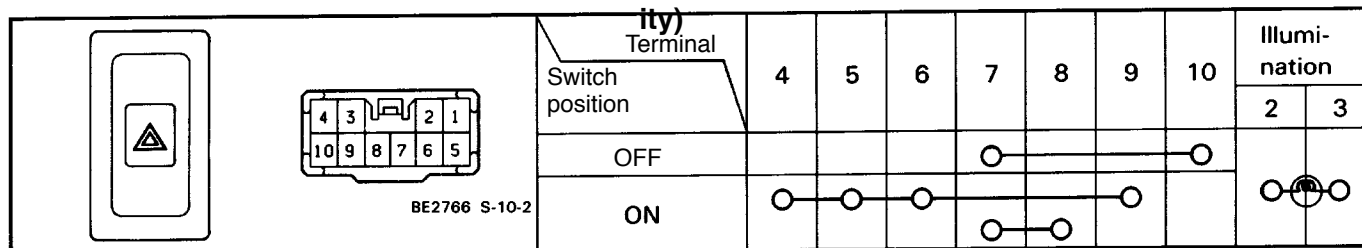

If continuity is not as specified, replace the switch.

### 2. INSPECT TURN SIGNAL FLASHER

#### (Operation)

- Connect the positive (+) lead from the battery to terminal 2 and the negative (-) lead to terminal 3.
- Connect the two turn signal light bulbs parallel to each other to terminals 1 and 3, check that the bulbs flash.

HINT: The turn signal lights should flash 60 to 120 times per minute.

If one of the front or rear turn signal lights has an open circuit, the number of flashers will be more than 140 per minute.

If operation is not as specified, replace the flasher.

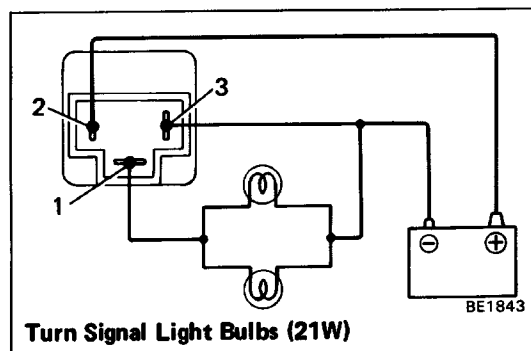



# WIPER AND WASHER SYSTEM Parts Location

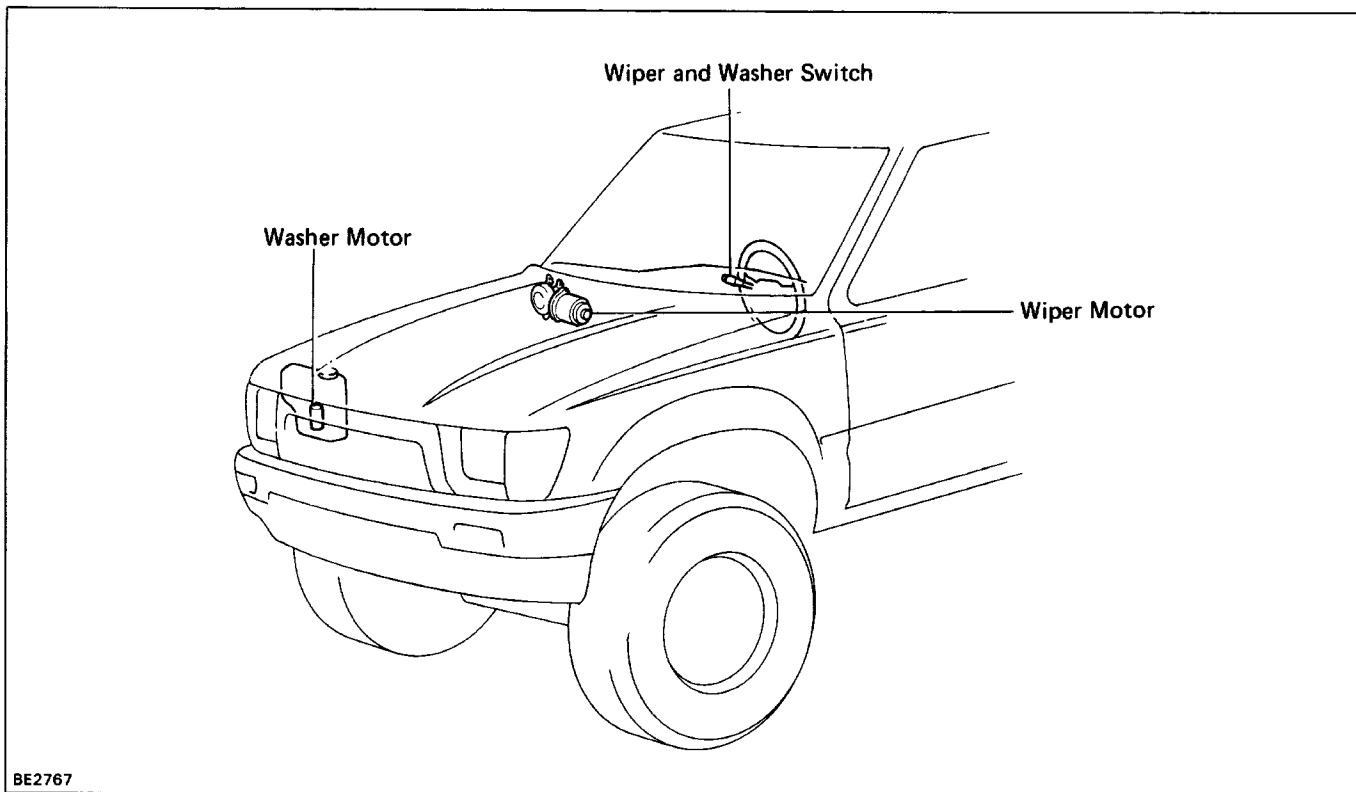

BE2767

## Wiring and Connector Diagrams (w/ MIST Wiper)

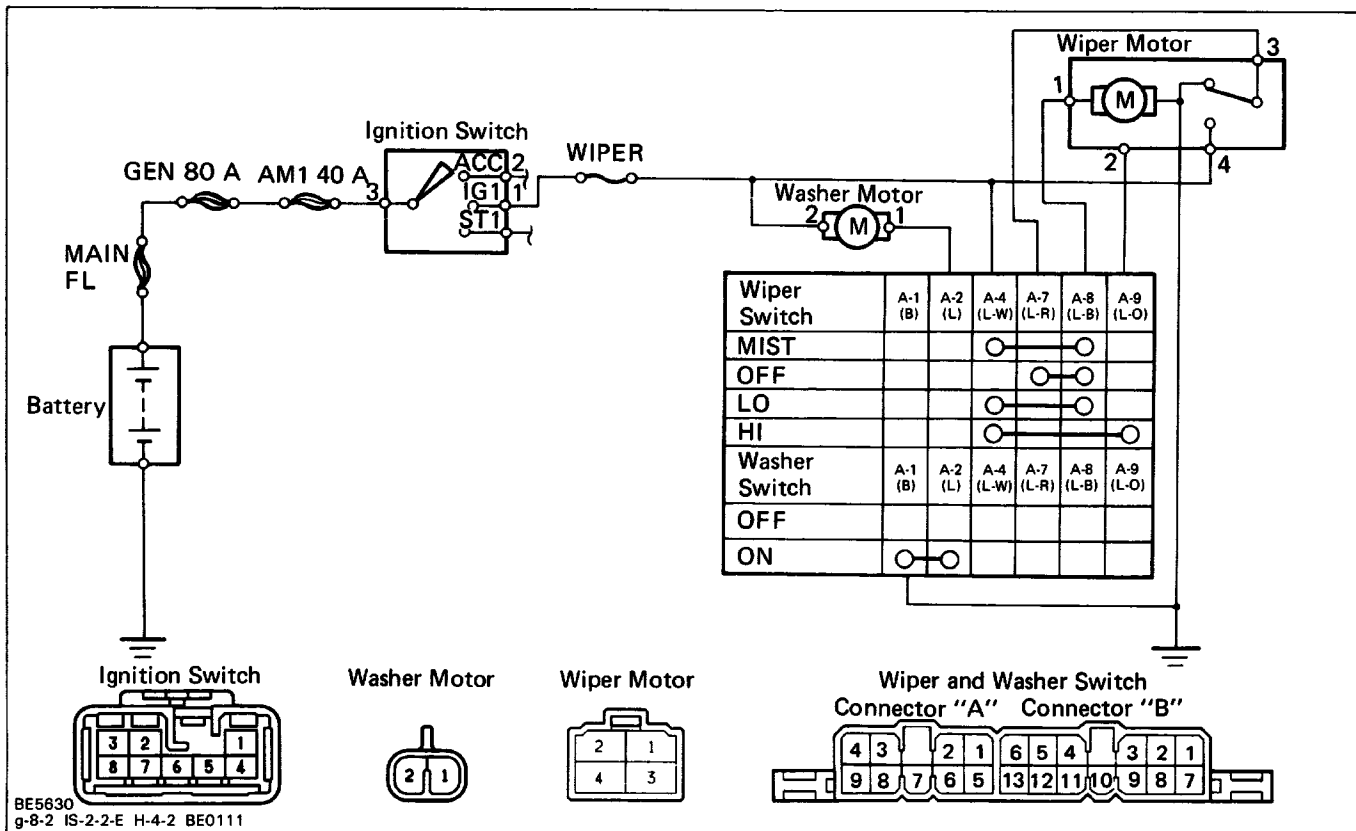

(w/ Intermittent Wiper)

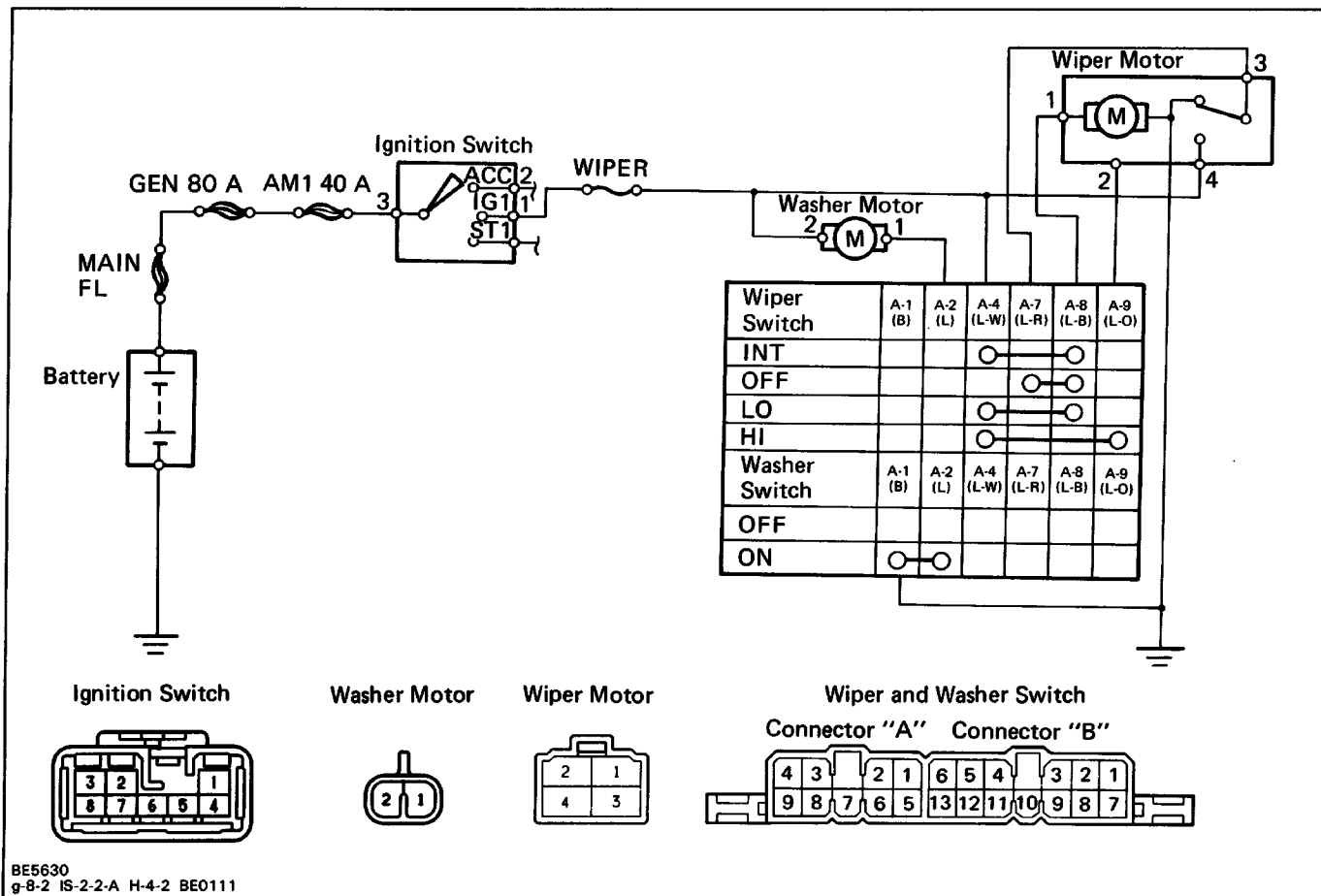

### Troubleshooting

Problem	Possible cause	Remedy	Page
Wipers do not operate or return to off position	WIPER fuse blown	Replace fuse and check for short	BE-3
	Wiper motor faulty Wiper switch faulty Wiper or ground faulty	Check motor Check switch Repair as necessary	BE-27 BE-26
Wipers do not operate in INT position	Wiper switch faulty Wiper motor faulty Wiring or ground faulty	Check switch Check motor Repair as necessary	BE-26 BE-27
Washers do not operate	Washer hose or nozzle clogged Washer motor faulty Washer switch faulty Wiring faulty	Repair as necessary Check motor Check switch Repair as necessary	BE-28 BE-28

### Parts Replacement

See replacement of combination switch on pages BE-1 6 to 18.

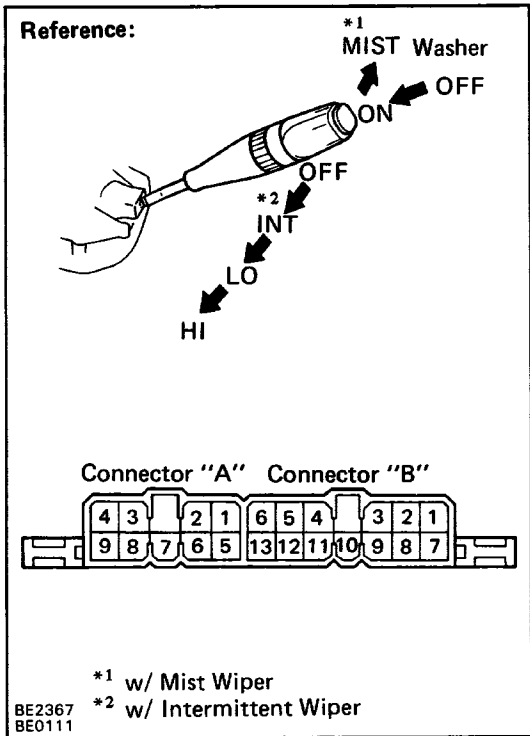

# Parts Inspection

## Wiper System

### 1. INSPECT SWITCHES

#### (Wiper and Washer Switch/Continuity)

w/ Mist Wiper

Terminal (Color) Switch position		A-1 (B)	A-2 (L)	A-4 (L-W)	A-7 (L-R)	A-8 (L-B)	A-9 (L-O)
Wiper	MIST			○		○	
	OFF				○	○	
	LO			○		○	
	HI			○			○
Washer	OFF						
	ON	○	○				

w/ Intermittent Wiper

Terminal (Color) Switch position		A-1 (B)	A-2 (L)	A-4 (L-W)	A-7 (L-R)	A-8 (L-B)	A-9 (L-O)
Wiper	MIST				○	○	
	INT			○		○	
	LO			○		○	
	HI			○			○
Washer	OFF						
	ON	○	○				

If continuity is not as specified, replace the switch.

#### (Wiper and Washer Switch /Intermittent Wiper Operation)

- Turn the wiper switch to INT position.
- (Variable Type)  
Turn the intermittent time control switch to FAST position.
- Connect the positive (+) lead from the battery to terminal 4/9 and the negative (-) lead to terminal 1/9.
- Connect the positive (+) lead from the voltmeter to terminal 8/9 and the negative (-) lead to terminal 1/9, check that the meter needle indicates battery positive voltage.
- After connecting terminal 7/9 to terminal 4/9, connect to terminal 1/9.

Then, check that the voltage rises from 0 volts to battery positive voltage within the times as shown in the table.

Non Variable Type

Switch position	Specified valve	
INT	3.3 ± 1 sec.	Battery positive voltage 0 volts

Variable Type

Switch position	Specified valve	
INT	FAST	1.6 ± 1 sec. Battery positive voltage 0 volts
	LOW	10.7 ± 5 sec. Battery positive voltage 0 volts

If operation is not as specified, replace the switch.

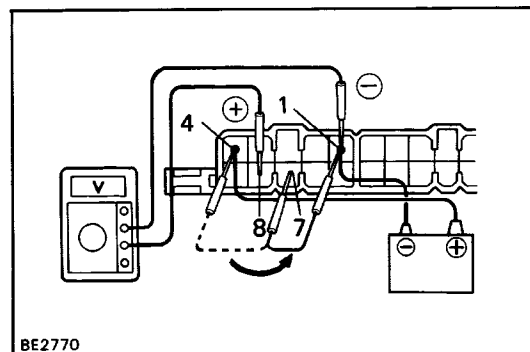
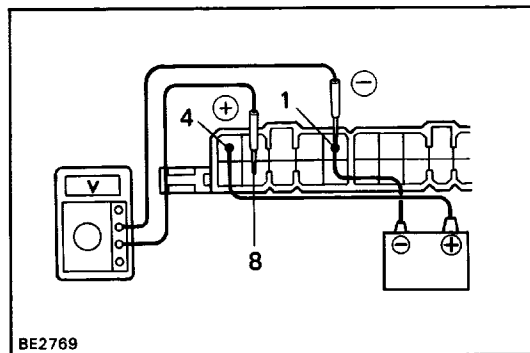

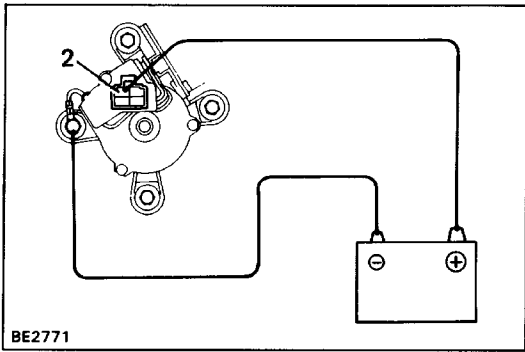

**2. INSPECT MOTOR**

(Operation at Low Speed)

Connect the positive (+) lead from the battery to terminal 2 and the negative (-) lead to the motor body, check that the motor operates at low speed.

If operation is not as specified, replace the motor.

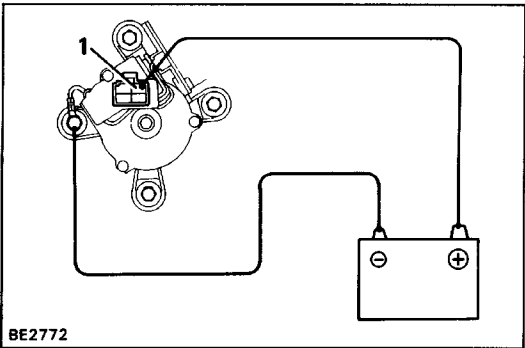

(Operation at High Speed)

Connect the positive (+) lead from the battery to terminal 1 and the negative (-) lead to the motor body, check that the motor operates at high speed.

If operation is not as specified, replace the motor.

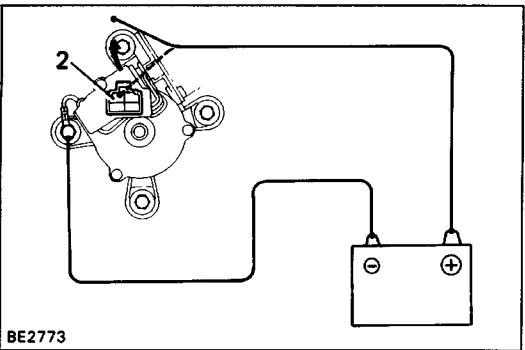

**(Operation, Stopping at Stop Position)**

(a) Operate the motor at low speed and stop the motor operation anywhere except at the stop position by disconnecting positive (+) lead from terminal 2.

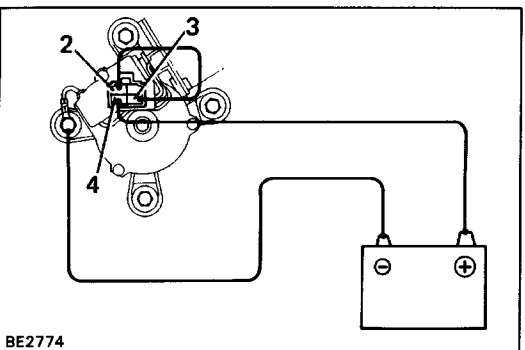

(b) Connect terminals 2 and 3.

(c) Connect the positive (+) lead from the battery to terminal 4 and the negative (-) lead to the motor body, check that the motor stops running at the stop position after the motor operates again.

If operation is not as specified, replace the motor.

## Washer System

### 1. INSPECT WASHER SWITCH

(Front Windshield Washer Switch)

See Wiper and Washer Switch on page [BE-27](#).

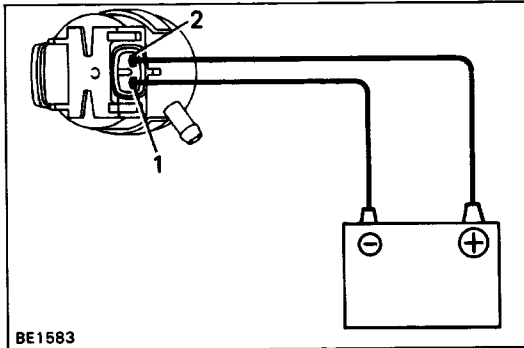

BE1583

### 2. INSPECT WASHER MOTOR

Connect the positive (+) lead from the battery to terminal 2 and the negative (-) lead to terminal 1, check that the motor operates.

**NOTICE:** These tests must be performed quickly (Within 20 seconds) to prevent the coil from burning out. If operation is not as specified, replace the motor.

# COMBINATION METER Parts Location

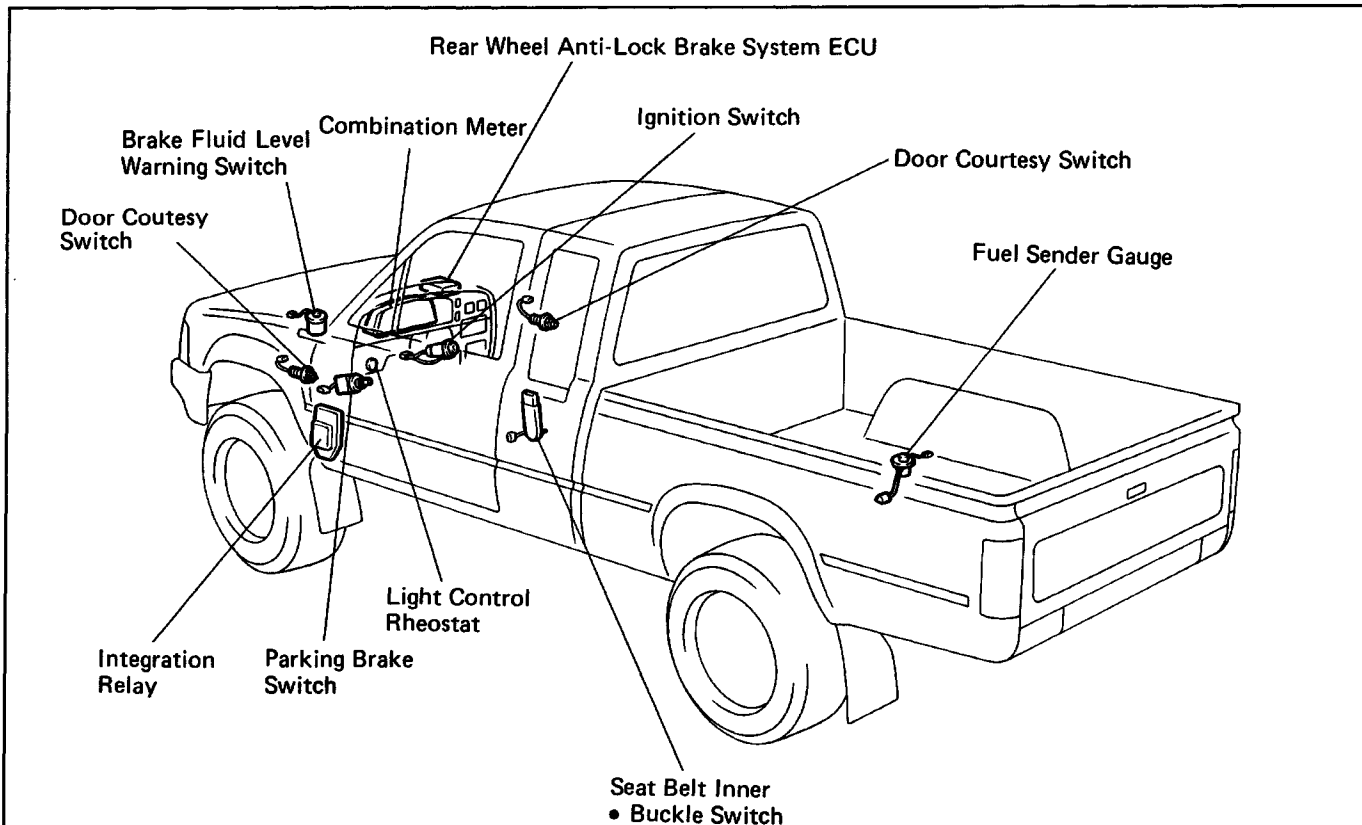

3VZ-E Engine

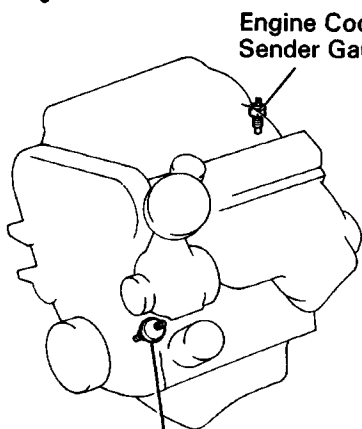

22R-E Engine

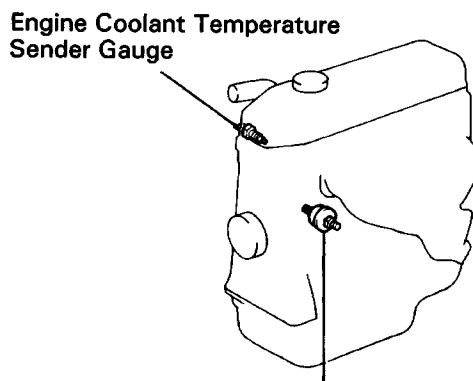

# Meter Circuit

(w/o Tachometer)

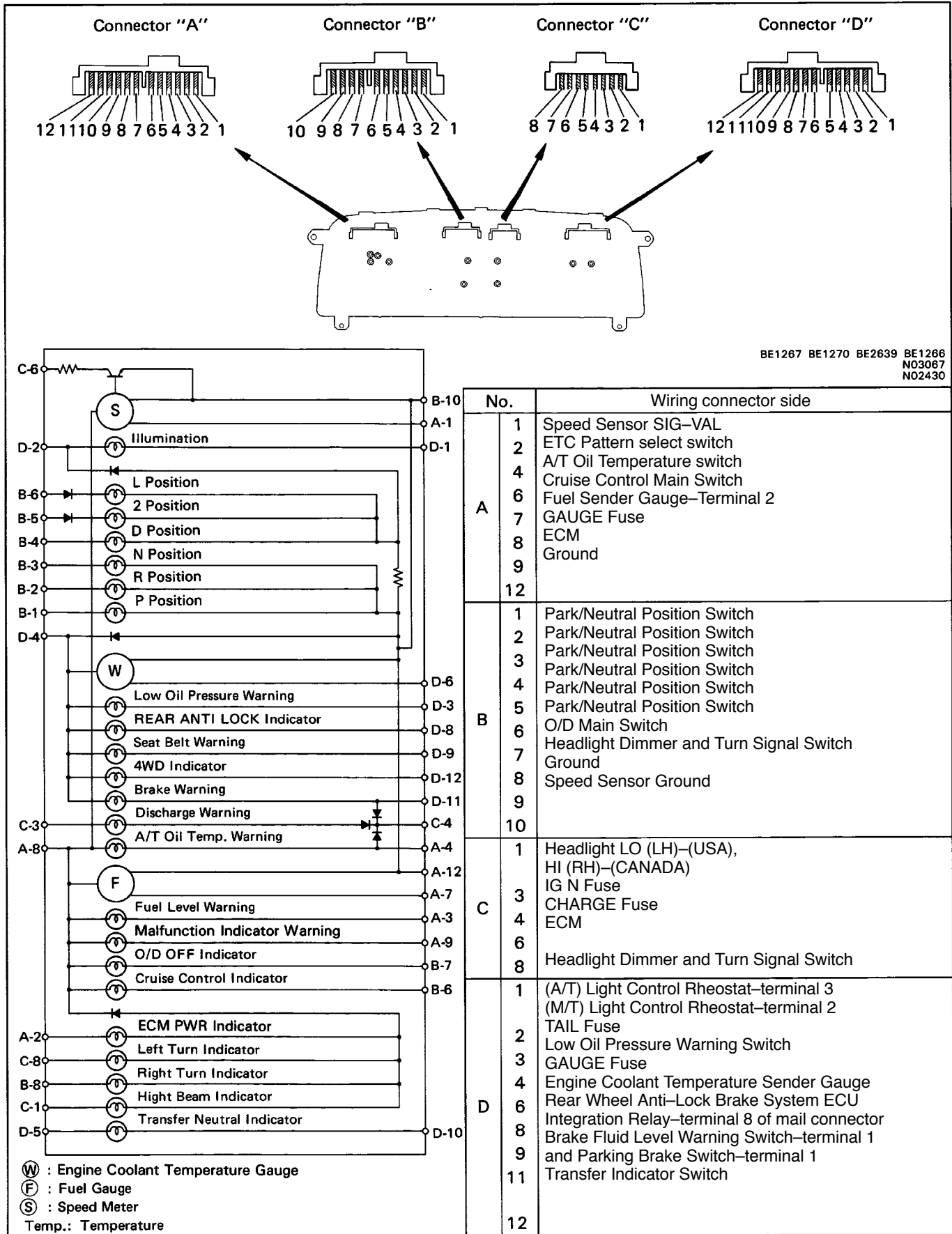

BE1267 BE1270 BE2639 BE1266  
N03067  
N02430

(w/ Tachometer)

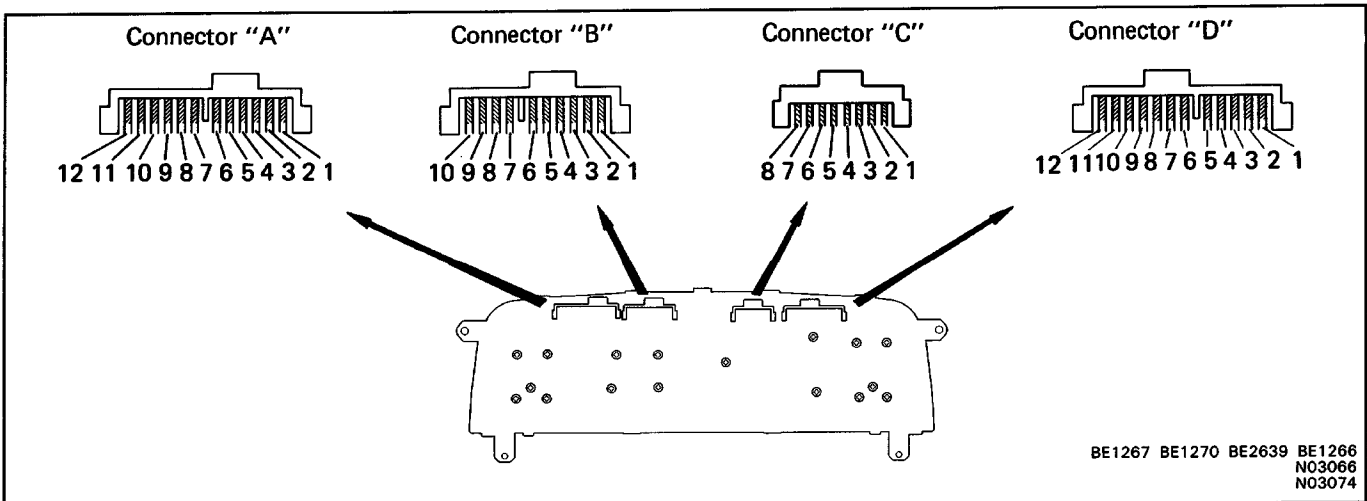

BE1267 BE1270 BE2639 BE1266  
N03066  
N03074

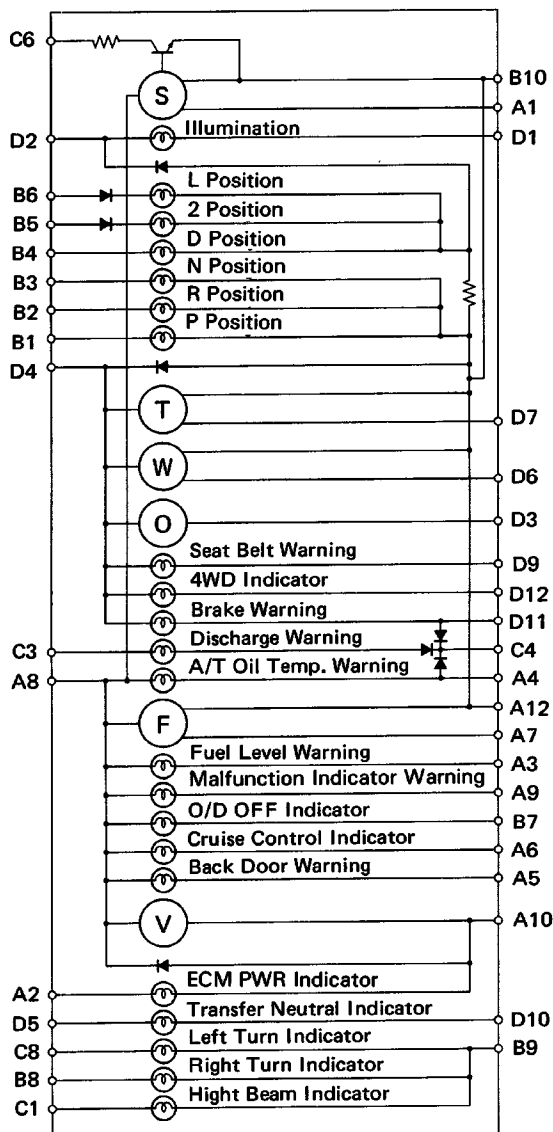

- Ⓣ : Tachometer
- Ⓜ : Engine Coolant Temperature Gauge
- Ⓞ : Oil Pressure Gauge
- ⓕ : Fuel Gauge
- Ⓥ : Volt Gauge
- Ⓢ : Speed Meter
- Temp.: Temperature

No.	Wiring connector side
A	1 Speed Meter SIG-VAL
	2 ECM Pattern Select Switch
	3 Fuel Sender Gauge-terminal 3
	4 A/T Oil Temperature Switch
	6 Cruise Control Main Switch
	6 Fuel Sender Gauge-terminal 4
	7 GAUGE Fuse
	8 ECM
	9 Ground
	10 Ground
B	1 Park/Neutral Position Switch
	2 Park/Neutral Position Switch
	3 Park/Neutral Position Switch
	4 Park/Neutral Position Switch
	5 Park/Neutral Position Switch
	6 O/D Main Switch
	7 Headlight Dimmer and Turn Signal Switch
	8 Ground
	9 Speed Sensor Ground
	10
C	1 Headlight LO (LH)-(USA), H I (R H)-(CANADA)
	3 IGN Fuse
	4 CHARGE Fuse
	6 ECM
8 Headlight Dimmer and Turn Signal Switch	
D	1 Light Control Rheostat-(DLX Grade) terminal 2, (SR5 and SR5V6 Grades) terminal 3
	2 TAIL Fuse
	2 Oil Pressure Sender Gauge
	3 GAUGE Fuse
	4 Engine Coolant Temperature Sender Gauge
	6 Igniter
	6 Rear Wheel Anti-Lock Brake System ECU
	7 Integration Relay-terminal 8 of mail connector
	8 Brake Fluid Level Warning Switch-terminal 1 and Parking Brake Switch-terminal 1
	9 Transfer Indicator Switch
	11
	12



## Troubleshooting

Problem	Possible cause	Remedy	Page
Gauges and indicator lights do not operate	GAUGE fuse faulty Wiring or ground faulty	Replace fuse and check for short Repair as necessary	BE-3
Voltmeter does not work	Voltmeter faulty Wiring or ground faulty	Check voltmeter Repair as necessary	BE-33
Tachometer does not operate	Tachometer faulty Wiring or ground faulty	Check tachometer Repair as necessary	BE-33
Fuel gauge does not operate	Receiver gauge faulty Sender gauge faulty Wiring or ground faulty	Check gauge Check gauge Repair as necessary	BE-34 BE-35
Engine Coolant temperature gauge does not operate	Receiver gauge faulty Wiring or ground faulty	Check gauge Repair as necessary	BE-36
Oil pressure gauge does not operate	Receiver gauge faulty Sender gauge faulty Wiring or ground faulty	Check gauge Check gauge Repair as necessary	BE-37 BE-38
Brake warning light does not light up	Bulb burned out Brake fluid level warning switch faulty Parking brake switch faulty Wiring or ground faulty	Replace bulb Check switch Check switch Repair as necessary	BE-38 BE-39
Seat belt warning light does not light up	Bulb burned out Integration relay faulty Wiring or ground faulty	Replace bulb Check relay Repair as necessary	BE-40
Discharge warning light does not light up	IGN fuse blown  CHARGE fuse blown  Bulb burned out Wiring or ground faulty	Replace fuse and check for short Replace fuse and check for short Replace bulb Repair as necessary	BE-3  BE-3

Standard indication	Allowable range
20	19 - 22
40	39 - 42.5
60	59.5 - 63.5
80	79.5 - 84
100	100 - 105

(km/h)

Standard indication	Allowable range
20	18 - 23
40	40 - 44
60	60 - 64.5
80	80 - 85
100	100 - 105
120	120 - 125.5
140	140 - 146
160	160 - 167

## Parts Inspection Speedometer System

### 1. INSPECT SPEEDOMETER (ON-VEHICLE)

- (a) Using a speedometer tester, inspect the speedometer for allowable indication error and check the operation of the odometer.

HINT: The wear and tire over or under inflation will increase the indication error.

If error.

- (b) Check the speedometer for pointer vibration and abnormal noise.

HINT: Pointer vibration can be caused by a loose speedometer cable.

### 2. INSPECT SPEED SENSOR

Check that there is continuity between terminals A and B four times per each revolution of the speedometer shaft. If operation is not as specified, replace the speedometer.

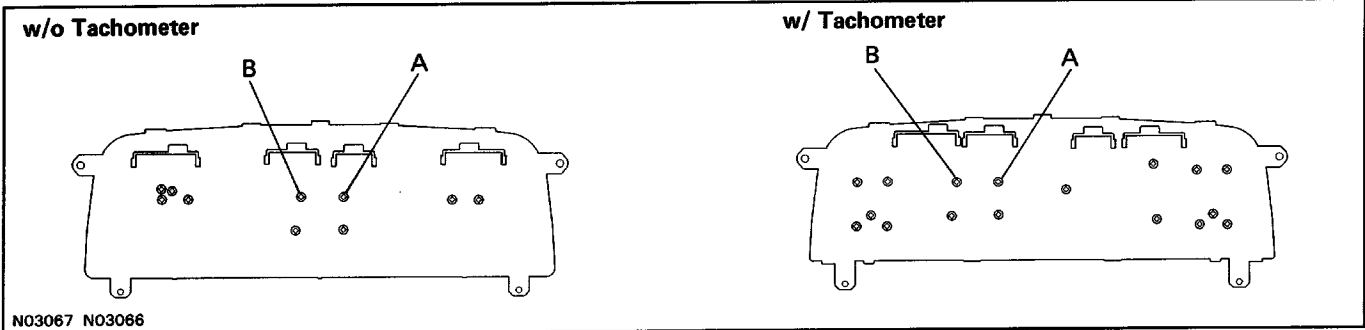

N03067 N03066

DC 13.5 V 200C (680F)	rpm
Standard indication	Allowable range
700	610 - 750
3,000	2,850 - 3,150
5,000	4,850 - 5,150
7,000	6,790 - 7,210

## Tachometer System

### INSPECT TACHOMETER (ON-VEHICLE)

- (a) Connect a tune-up test tachometer, and start the engine.

**NOTICE:**

- Reversing the connection of the tachometer will damage the transistors and diodes inside.
- When removing or installing the tachometer, be careful not to drop or subject it to heave shocks.

- (b) Compare the tester and tachometer indications. If error is excessive, replace the tachometer.

### Volt Gauge System

#### INSPECT VOLT GAUGE

Measure the resistance between terminals A and B.

**Resistance: Approx. 347**

If resistance value is not as specified, replace the gauge.

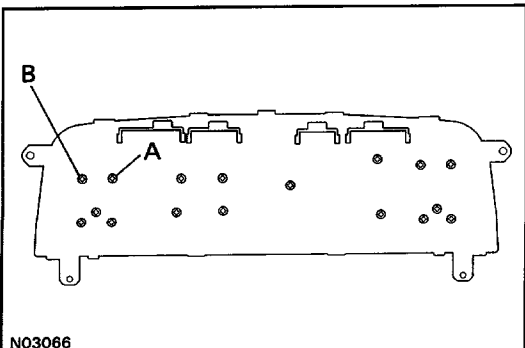

N03066

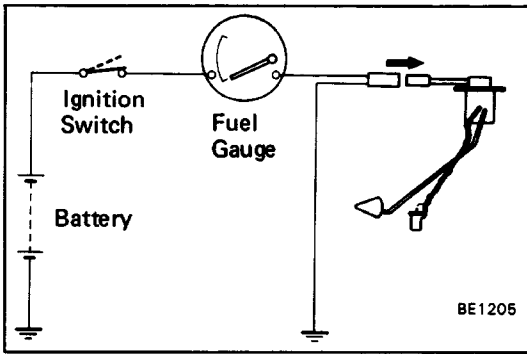

## Fuel Gauge System

### 1. INSPECT RECEIVER GAUGE

- (a) Disconnect the connector from the sender gauge.
- (b) Turn the ignition switch ON, check that the receiver gauge needle indicates EMPTY.

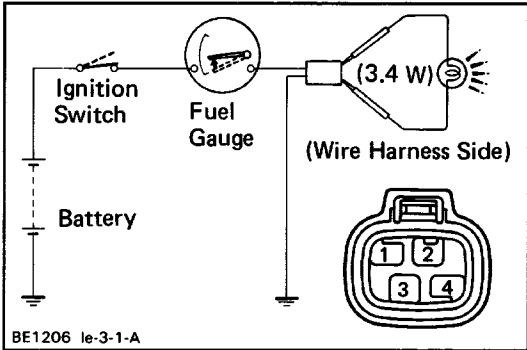

- (c) Connect terminals 1 and 2 on the wire harness side connector through a 3.4 W test bulb.
- (d) Turn the ignition switch ON, check that the test bulb lights up and the receiver gauge needle moves towards the full side.

HINT: (w/ Tachometer)

Because of the silicon oil in the gauge, it will take a short time for the needle to stabilize.

If operation is not as specified, inspect the receiver gauge resistance, and the voltage regulator (w/o Tachometer).

#### (Voltage Regulator: w/o Tachometer)

- (a) Connect the positive (+) lead from the battery to terminal A and negative (-) lead to terminal B.
- (b) Connect the positive (+) lead from the voltmeter to terminal C and the negative (-) lead to terminal B, check that the voltmeter needle vibrates near the 7 V position.

If voltage value is not as specified, replace the receiver gauge.

#### (Resistance)

Measure the resistance between terminals.

If resistance value is not as specified, replace the receiver gauge.

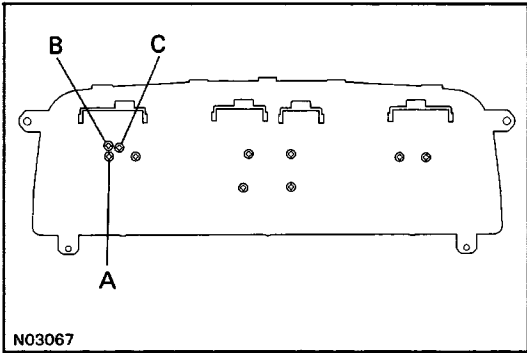

Between terminals	Resistance ( / )	
	w/o Tachometer	w/ Tachometer
A - B	Approx. 55	Approx. 123
A - C	-	Approx. 260
B - C	-	Approx. 137

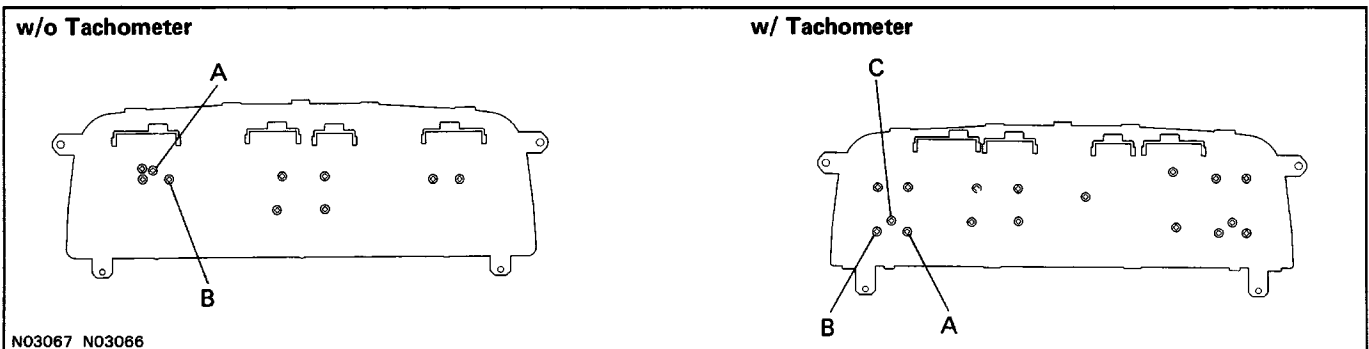

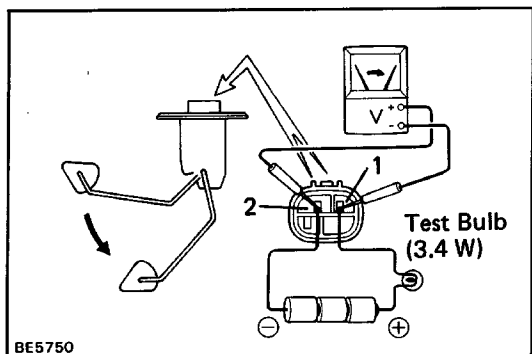

## 2. INSPECT SENDER GAUGE

(Operation)

- (a) Connect a series of three 1.5 v dry cell batteries.
- (b) Connect the positive (+) lead from the dry cell batteries to terminal 2 through a 3.4 W test bulb and the negative (-) lead to terminal 1.
- (c) Connect the positive (+) lead from the voltmeter to terminal 2 and negative (-) lead to terminal 1.
- (d) Check that the voltage rises as the float is moved from the top to bottom position.

If operation is not as specified, replace the sender gauge.

**(Resistance)**

Measure the resistance between terminals 1 and 3.

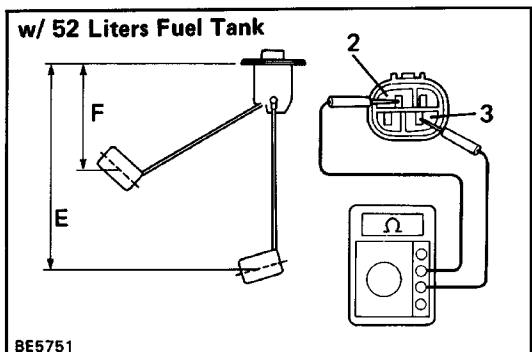

w/ 52 Liters Fuel Tank

	Float position mm (in.)	Resistance ( / )
F	Approx. 121 (4.76)	Approx. 3
E	Approx. 263 (10.35)	Approx. 110

w/ 65 Liters Fuel Tank

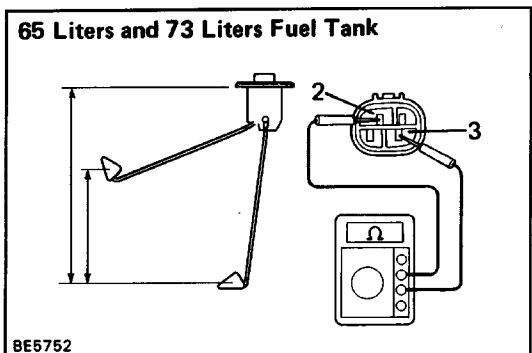

Models	Float position		Resistance ( / )
2WD	F	Approx. 96 (3.78)	Approx. 3
	E	Approx. 281 (11.06)	Approx. 110
4WD	F	Approx. 108 (4.25)	Approx. 3
	E	Approx. 300 (11.81)	Approx. 110

w/ 73 Liters Fuel Tank

	Float position	Resistance ( / )
F	Approx. 116 (4.57)	Approx. 3
E	Approx. 319 (12.56)	Approx. 110

If resistance value is not as specified, replace the sender gauge.

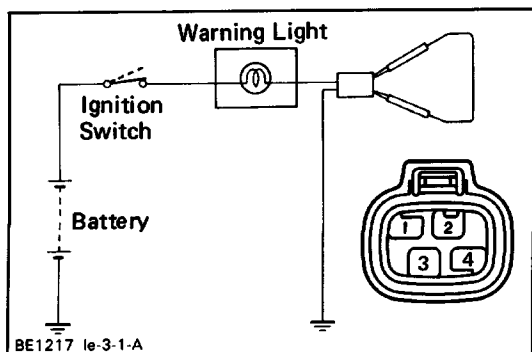

## Fuel Level Warning System

### 1. INSPECT WARNING LIGHT

- (a) Disconnect the connector from the sender gauge.
- (b) Connect terminals 1 and 3 on the wire harness side connector.
- (c) Turn the ignition switch ON, check that the warning light will come on.  
If the warning light does not come on, test the bulb.

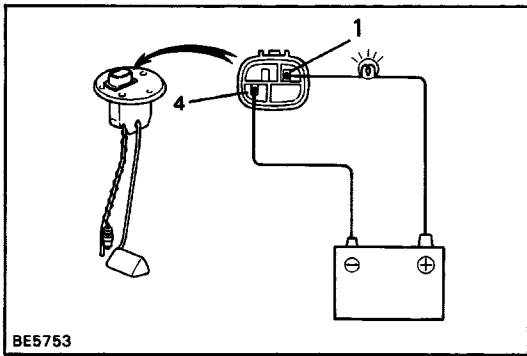

**2. INSPECT WARNING SWITCH**

- (a) Apply battery positive voltage between terminals 1 and 4 through a 3.4 W test bulb, check the bulb lights up.

HINT: It will take a short time for the bulb to light up.

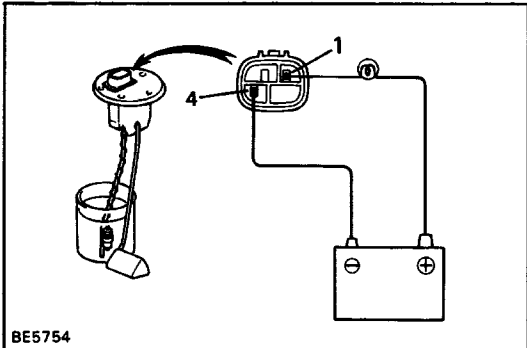

- (b) Submerge the switch in fuel, check that the bulb goes out.  
If operation is not as specified, replace the sender gauge.

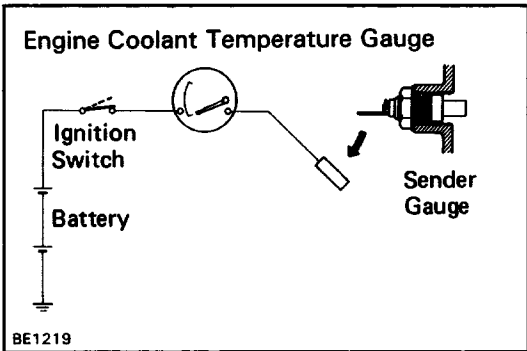

**Engine Coolant Temperature Gauge System**

**INSPECT RECEIVER GAUGE**

**(Operation)**

- (a) Disconnect the connector from the sender gauge.
- (b) Turn the ignition switch ON, check that the receiver gauge needle indicates cool.

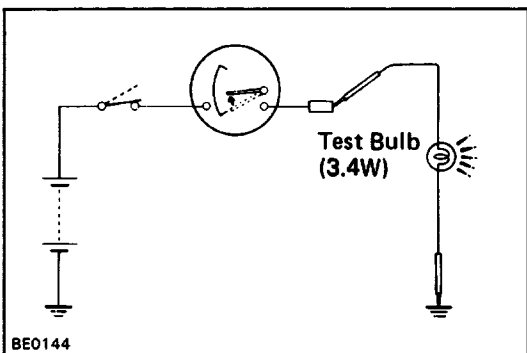

- (c) Ground terminal on the wire harness side connector through a 3.4 W test bulb.
- (d) Turn the ignition switch ON, check that the bulb lights up and the receiver gauge needle moves towards the hot side.

If operation is not as specified, replace the sender gauge. Then, recheck the system.

If operation is not as specified, measure the receiver gauge resistance.

Between terminals	Resistance ( / )	
	w/o Tachometer	w/ Tachometer
A → B	Approx. 25	Approx. 57
A → C	—	Approx. 135
B → C	—	Approx. 217

**(Resistance)**

Measure the resistance between terminals.

HINT: Connect the test leads so that the current from the ohmmeter can flow according to the above order.

If resistance value is not as specified, replace the receiver gauge.

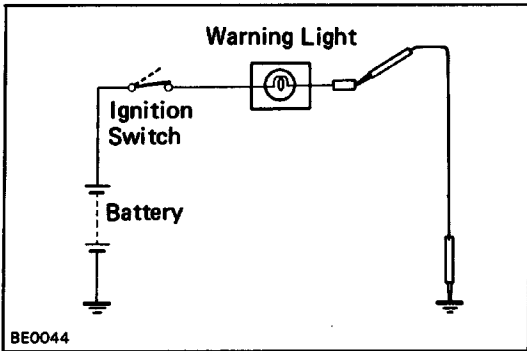
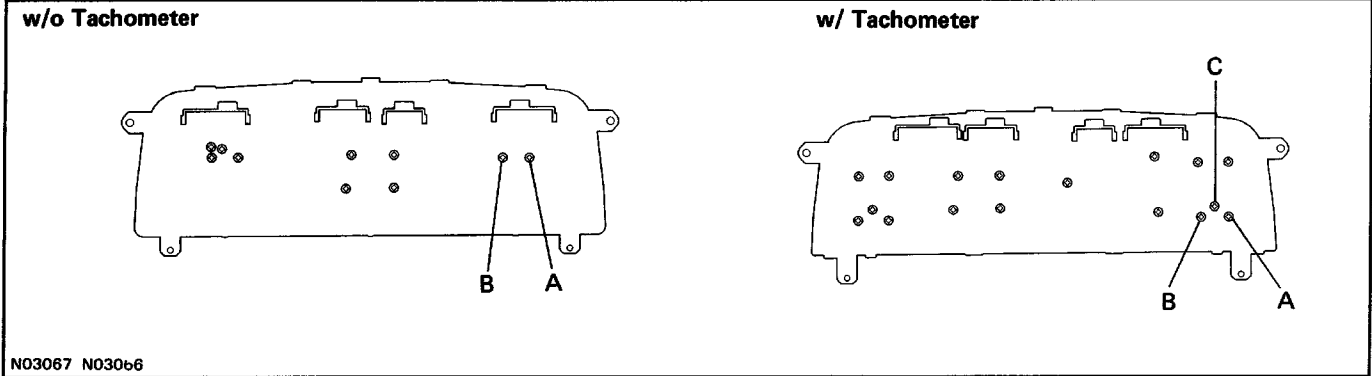

**Low Oil Pressure Warning System**

**1. INSPECT WARNING LIGHT**

- (a) Disconnect the connector from the warning switch and ground terminal on the wire harness side connector.
  - (b) Turn the ignition switch ON, check that the warning light will come on.
- If the warning light does not come on, test the bulb.

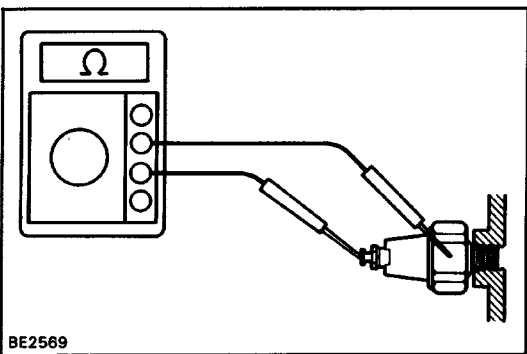

**2. INSPECT WARNING SWITCH**

- (a) Disconnect the connector from the switch.
- (b) Check that there is continuity between terminal and ground with the engine stopped.
- (c) Check that there is no continuity between terminal and ground with the engine running.

HINT: Oil pressure should be over 0.3 kg/cm<sup>2</sup> (4.3 psi, 29 kPa).

If operation is not as specified, replace the switch.

**Oil Pressure Gauge System**

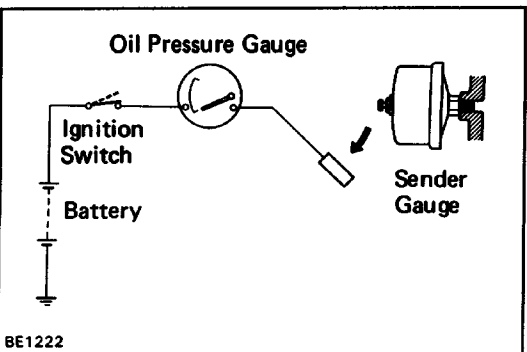

**1. INSPECT RECEIVER GAUGE**

**(Operation)**

- (a) Disconnect the connector from the sender gauge.
- (b) Turn the ignition switch ON, check that the receiver gauge needle indicates LOW.

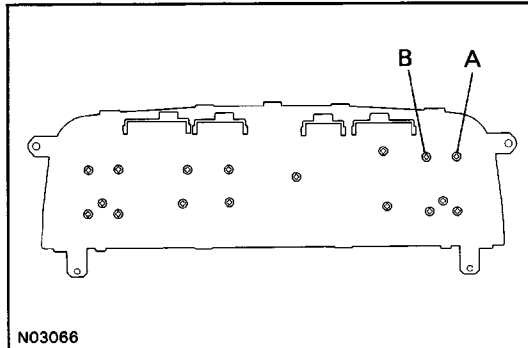
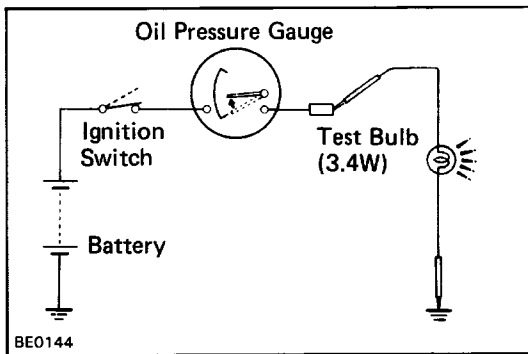

- (e) Ground terminal on the wire harness side connector through a 3.4 W test bulb.
- (d) Turn the ignition switch ON, check that the bulb lights up and the receiver gauge needle moves to the high side.  
If operation is not as specified, measure the receiver gauge resistance.

### (Resistance)

Measure the resistance between terminals A and B.

**Resistance: Approx. 25**

If resistance value is not as specified, replace the receiver gauge.

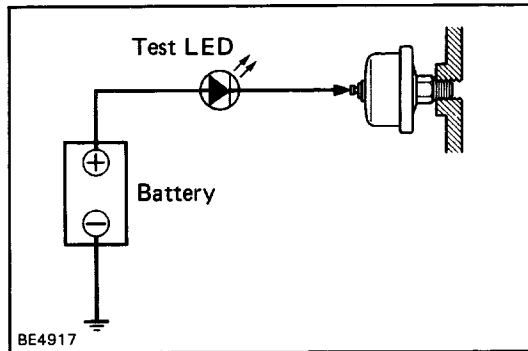

## 2. INSPECT SENDER GAUGE

- (a) Disconnect the connector from the sender gauge.
- (b) Apply battery positive voltage to the sender gauge terminal through a test LED.
- (c) Check that the bulb does not light when the engine is stopped.
- (d) Check that the LED flashes when the engine is running. The number of flashed should vary with engine speed.

If operation is not as specified, replace the sender gauge.

## Brake Warning System

### 1. INSPECT WARNING LIGHT

- (a) Disconnect the connectors from the level warning switch and parking brake switch.
- (b) Connect terminals on the wire harness side connector of the level warning switch connector.
- (c) Remove the CHARGE fuse and turn the ignition switch ON, check that the warning light will come on.

If the warning light does not come on, test the bulb.

### 2. INSPECT SWITCHES

#### (Brake Fluid Level Warning Switch)

- (a) Check that there is no continuity between terminals with the switch OFF (float up).
- (b) Check that there is continuity between terminals with the switch ON (float down).

If operation is not as specified, replace the switch.

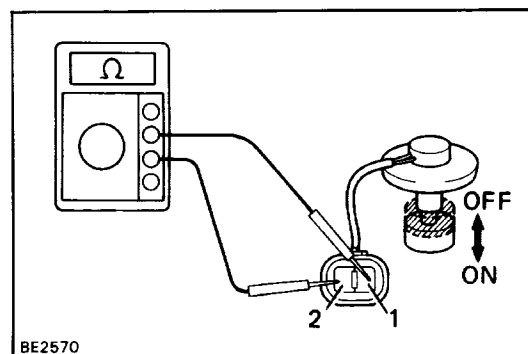
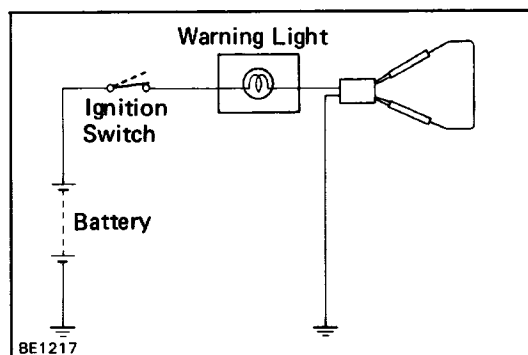

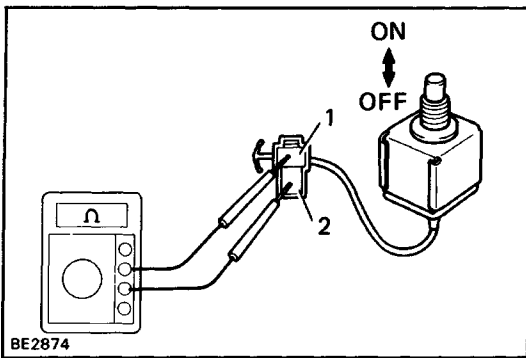

(Parking Brake Switch)

- (a) Check that there is continuity between terminals with the switch ON (switch pin released).
  - (b) Check that there is no continuity between terminals with the switch OFF (switch pin pushed).
- If operation is not as specified, replace the switch.



## Seat Belt Warning System

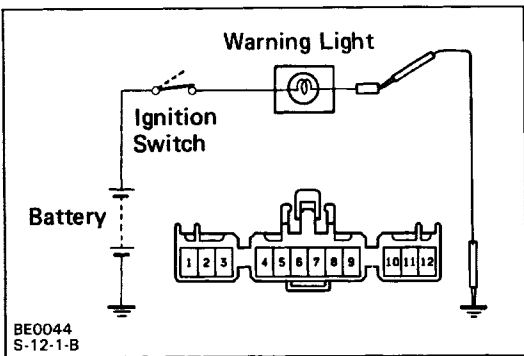
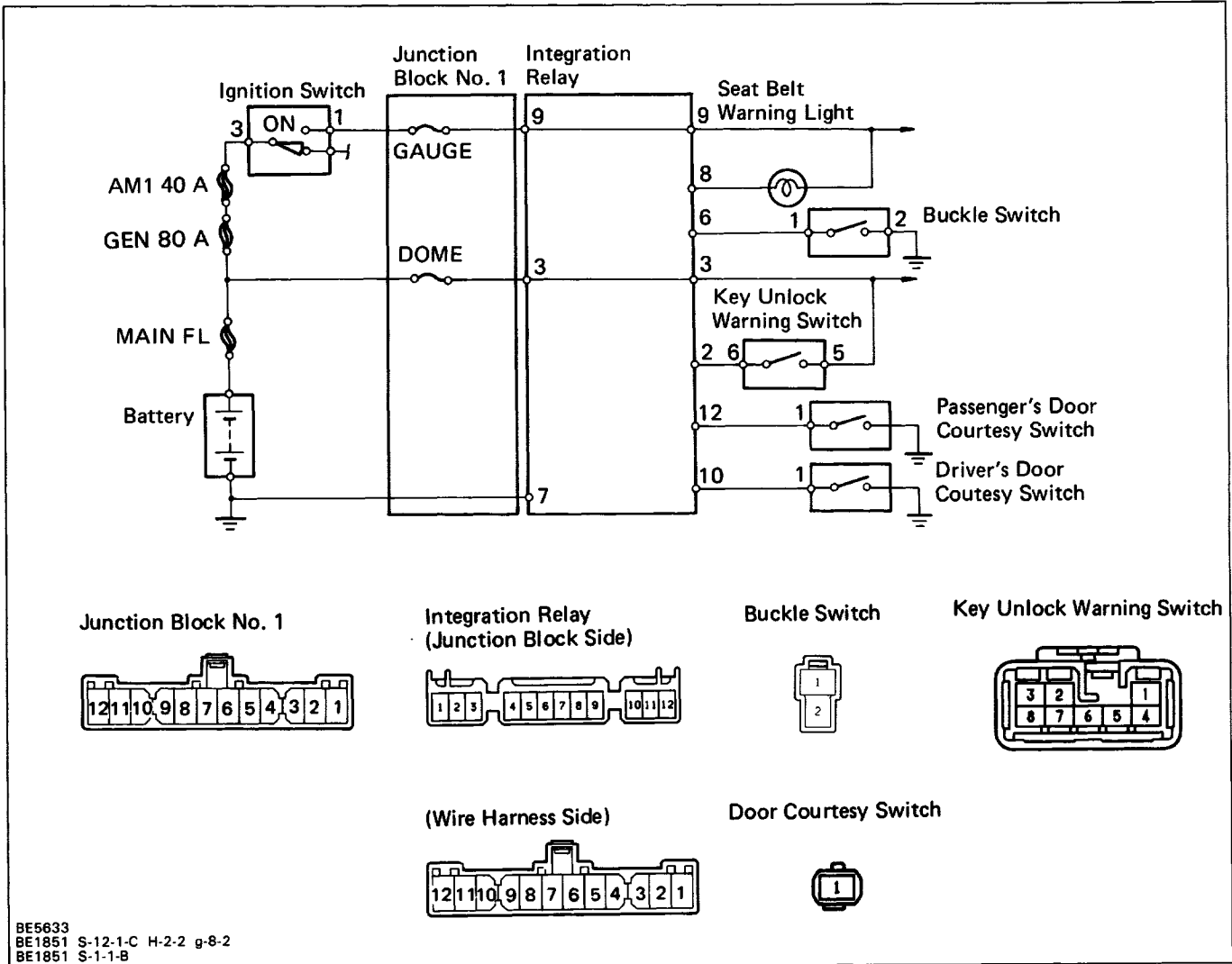

### 1. INSPECT WARNING SWITCH

- (a) Disconnect the wire harness side connector from the integration relay.
- (b) Ground terminal 8 on the wire harness side connector.
- (c) Turn the ignition switch ON, check that the warning light lights up.  
If the warning light does not light up, test the bulb.

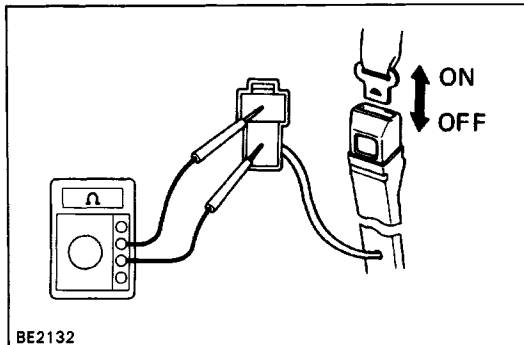

### 2. INSPECT BUCKLE SWITCH

- (a) Check that there is continuity between terminal: with the switch ON (belt unfastened).
  - (b) Check that there is no continuity between terminal: with the switch OFF (belt fastened).
- If operation is not as specified, replace the seat belt inner assembly.

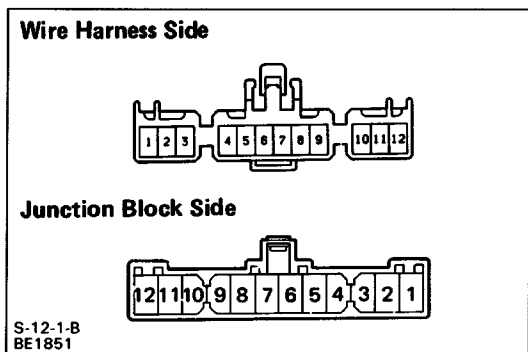

### 3. INSPECT INTEGRATION RELAY

Remove the integration relay and inspect the connectors on the wire harness side and the junction block side as shown in the chart.

#### Wire Harness Side

Check for	Tester connection	Condition	Specified value	
Continuity	2 - 3	Key unlock warning switch position	OFF (Ignition key removed) ON (Ignition key set)	No continuity Continuity
		6 - Ground	Buckle switch position	OFF (Belt fastened) ON (Belt unfastened)
	8 - 9		Constant	
	10 - Ground	Driver's door courtesy switch position	OFF (Door closed) ON (Door opened)	No continuity Continuity
			12 - Ground	Passenger's door courtesy switch position

\*There is resistance because this circuit is included the bulb.

#### Junction Block Side

Check for	Tester connection	Condition	Specified value
Continuity	7 - Ground	Constant	Continuity
Voltage	3 - Ground	Constant	Battery positive voltage
		Ignition switch position	LOCK or ACC ON

If circuit is as specified, replace the relay.

#### Open Door Warning System

##### 1. INSPECT WARNING LIGHT

- (a) Disconnect the connector from the door courtesy switch and ground terminal on the wire harness side.
- (b) Turn the ignition switch ON, check that the warning light lights up.  
If the warning light does not light up, test the bulb.

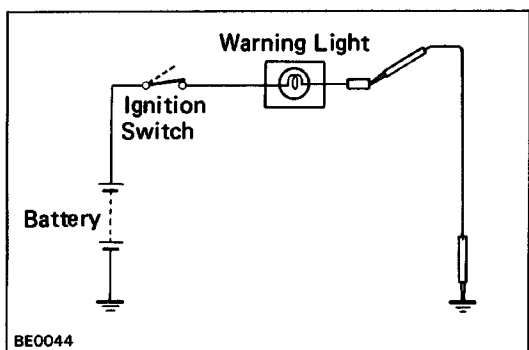

BE0044

##### 2. INSPECT COURTESY SWITCH

- (a) Check that there is continuity between terminal and the switch body with the switch ON (switch pin released).
- (b) Check that there is no continuity between terminal and the switch body with the switch OFF (switch pin pushed in).

If operation is not as specified, replace the switch.

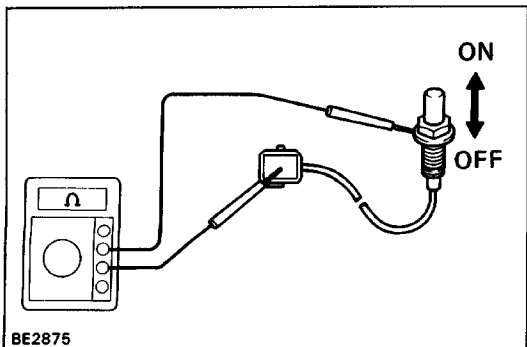

BE2875

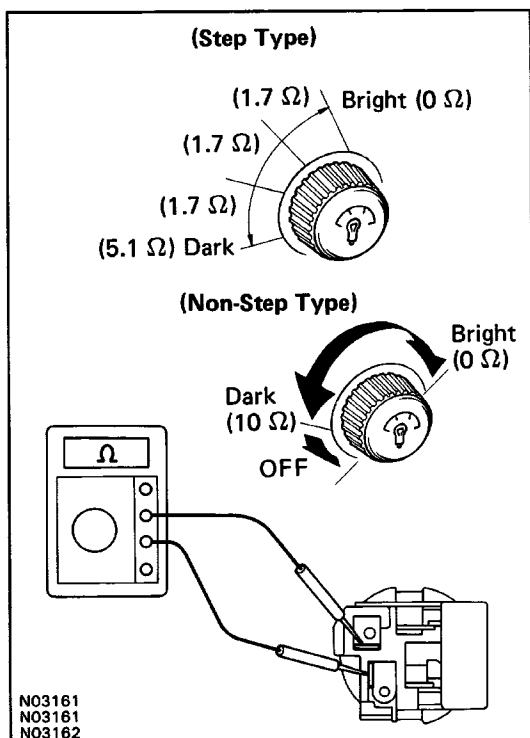

## Illumination Control System

### INSPECT LIGHT CONTROL RHEOSTAT

#### 1. STEP TYPE (w/ o Tachometer)

Gradually turn the rheostat knob from the bright side to dark side, check that the resistance between terminals increases from approximately 0 to 5.1/ .

If operation is not as specified, replace the rheostat.

#### 2. NON-STEP TYPE (w/ Tachometer)

- Turn the rheostat knob OFF, check that there is no continuity between terminals. (Rheostat knob turned to fully counterclockwise)
- Gradually, turn the rheostat knob from the dark side to bright side, check that the resistance decreases from 10 to 0 ohm. (Rheostat knob turned to clockwise)

If operation is not as specified, replace the rheostat.

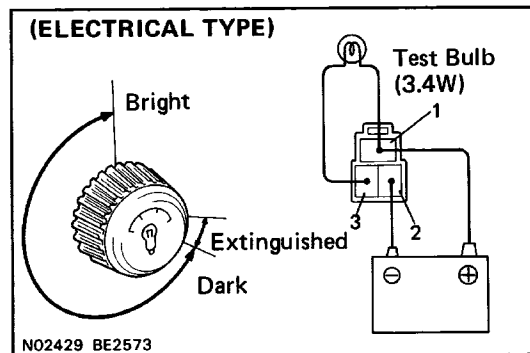

#### 3. ELECTRICAL TYPE (w/ All AIT Vehicle)

- Connect terminals 1 and 3 through a 3.4 W test bulb.
- Connect the positive (+) lead from the battery to terminal 1 and the negative (-) lead to terminal 2.
- Turn the rheostat knob to fully counterclockwise check that the test bulb goes out.
- Gradually turn the rheostat knob to clockwise, check that the test bulb brightness changes from dark to bright.

If operation is not as specified, replace the rheostat.

# POWER WINDOW CONTROL SYSTEM Parts Location

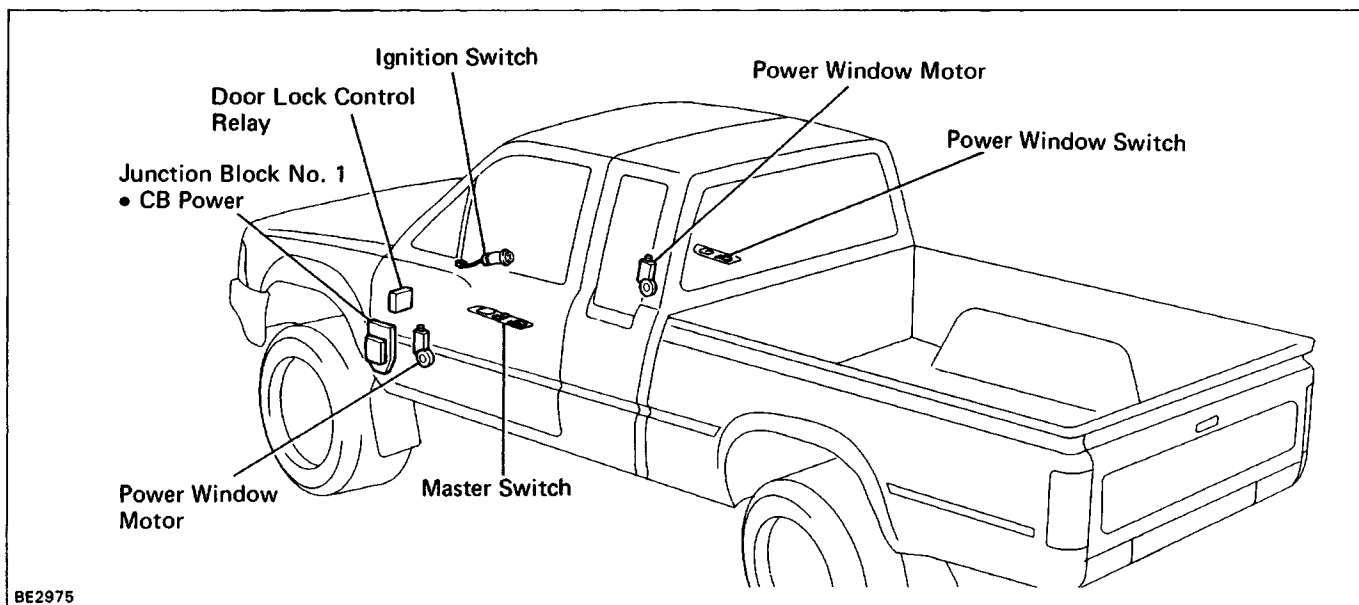

BE2975

## Wiring and Connector Diagrams

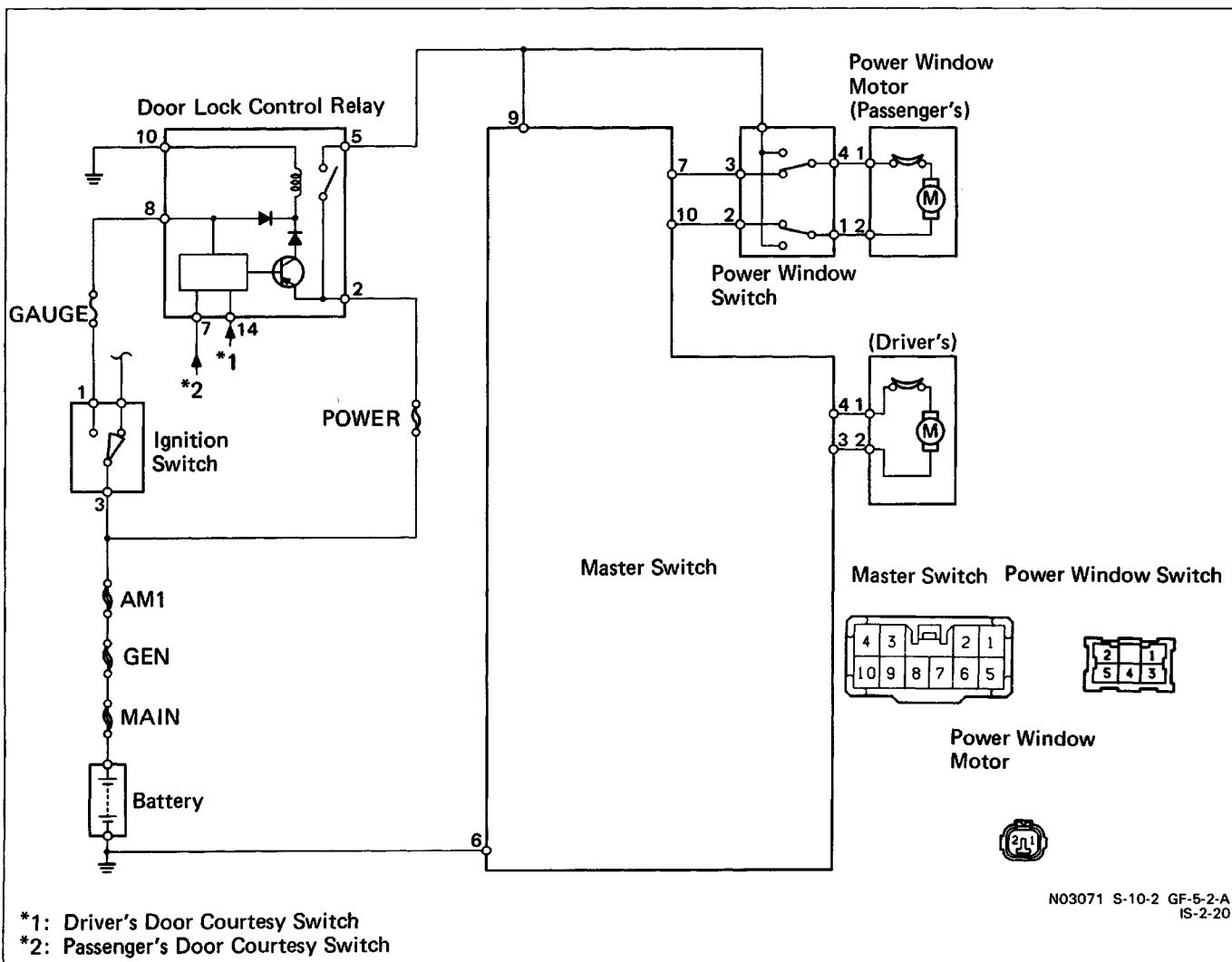

## Troubleshooting

Problem	Possible cause	Remedy	Page
Power window does not operate at all	GAUGE fuse blown	Replace fuse and check for short	BE-3
	Door lock control relay faulty Wiring or ground faulty	Check relay Repair as necessary	BE-51
One touch power window does not operate	Power window master switch faulty	Check switch	BE-44
Only one window does not operate	Power window switch faulty	Check switch	BE-46
	Power window motor faulty Wiring or ground faulty	Check motor Repair as necessary	BE-46

## Parts Inspection

### 1. INSPECT SWITCHES (Master Switch/Continuity)

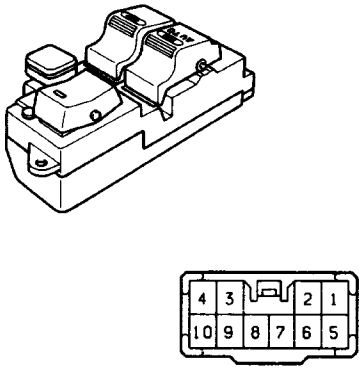
	Window operation		Driver's				Passenger's			
	Terminal	Switch position	3	4	6	9	6	7	9	10
Window unlock	UP		○	○	○	○	○	○	○	○
	OFF		○	○	○		○	○	○	○
	DOWN		○	○	○	○	○	○	○	○
Window lock	UP		○	○	○	○			○	○
	OFF		○	○	○		○	○	○	○
	DOWN		○	○	○	○	○	○		

BE2877  
S-10-2

If continuity is not as specified, replace the switch.

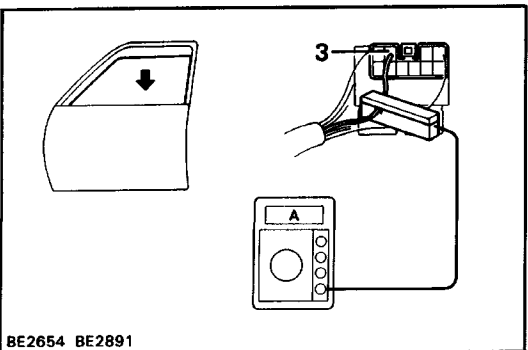
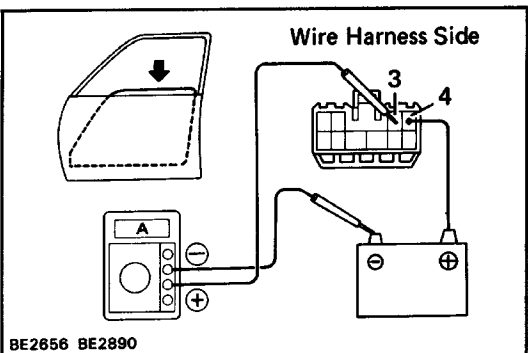
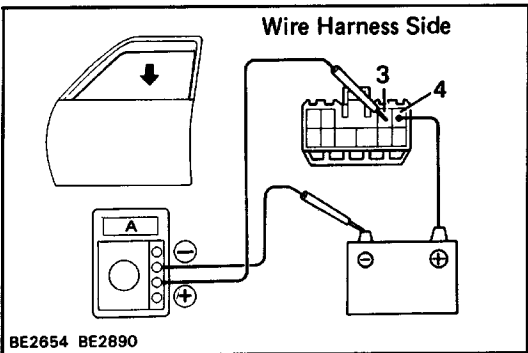
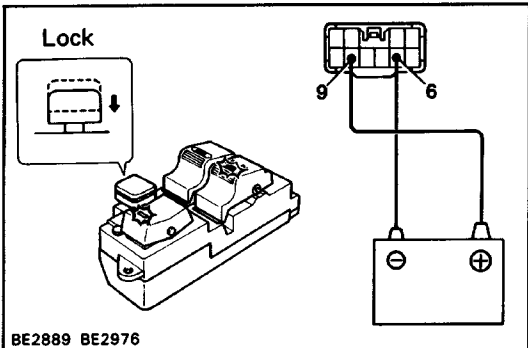
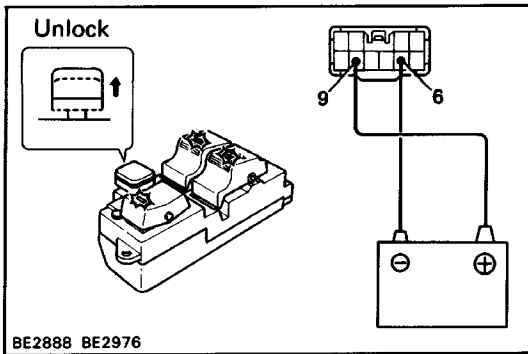

**(Master Switch: Illumination)**

- (a) Set the window lock switch to the unlock position.
- (b) Connect the positive (+) lead from the battery to terminal 9 and negative (-) lead to terminal 6, check that all the illuminations light up.

- (c) Set the window lock switch to the lock position, check that the passenger's power window switch illumination goes out. If operation is not as specified, replace the master switch.

**(Master Switch: One Touch Power Window System)**

**Inspection using an ammeter:**

- (a) Disconnect the connector from the master switch.
- (b) Connect the positive (+) lead from the ammeter to terminal 3 on the wire harness side connector and the negative (-) lead to negative terminal of the battery.
- (c) Connect the positive (+) lead from the battery to terminal 4 on the wire harness side connector.
- (d) As the window goes down, check that the current flows approximately 7 A.
- (e) Check that the current increases approximately 14.5 A or more when the window stops going down.

HINT: The circuit breaker opens some 4–40 seconds after the window stops going down, so the check must be made before the circuit breaker operates.

If operation is not as specified, replace the master switch.

**Inspection using an ammeter with a current-measuring probe:**

- (a) Remove the master switch with connector connected.
- (b) Attach a current-measuring probe to terminal 3 of the wire harness.
  - i Turn the ignition switch ON and set the power window switch in the down position.
- (d) As the window goes down, check that the current flows approximately 7 A.

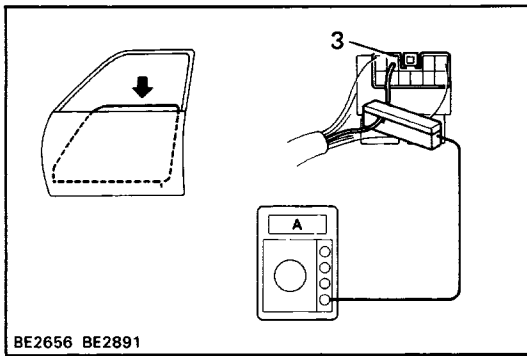

- (e) Check that the current increases approximately 14.5 A or more when the window stops going down.

HINT: The circuit breaker opens some 4–40 seconds after the window stops going down, so that check must be made before the circuit breaker operates. If operation is not as specified, replace the master switch.

**(Power Window Switch/ Continuity)**

<p>BE2658 G-5-2-A</p>	Terminal Switch position	1	2	3	4	5
	UP	○		○	○	○
	OFF	○	○	○	○	
	DOWN	○	○		○	○

If continuity is not as specified, replace the switch.

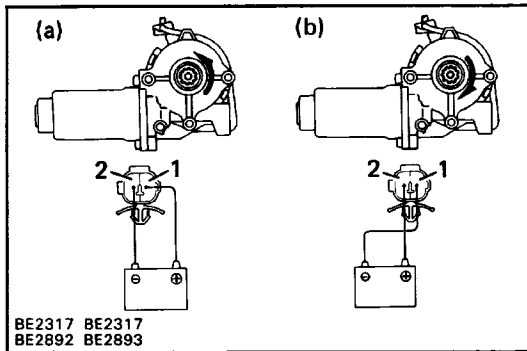

**2. INSPECT POWER WINDOW MOTOR**

(Left Side Door Motor/ Motor Operation)

- (a) Connect the positive (+) lead from the battery to terminal 1 and negative (-) lead to terminal 2, check that the motor turns counterclockwise.
- (b) Reverse the polarity, check that the motor turns clockwise.

If operation is not as specified, replace the motor.

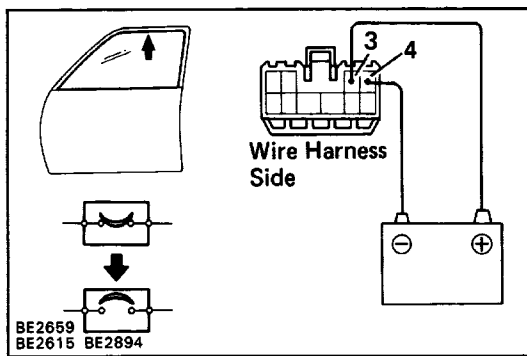

**(Left Side Door Motor/ Circuit Breaker Operation)**

- (a) Disconnect the connector from the master switch.
- (b) Connect the positive (+) lead from the battery to terminal 3 and negative (-) lead to terminal 4 on the wire harness side connector, and raise the window to full closed position.
- (c) Continue to apply voltage, check that there is a circuit breaker operation noise within approximately 4 to 40 seconds.
- (d) Reverse the polarity, check that the window begins to descend within approximately 60 seconds. If operation is not as specified, replace the motor.

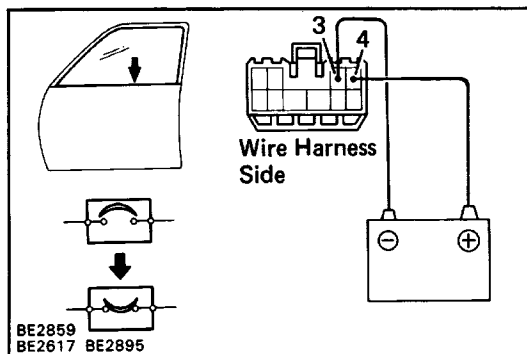

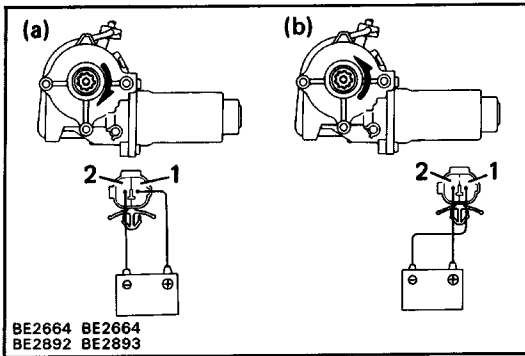
**(Right Side Door Motor/ Motor Operation)**

- (a) Connect the positive (+) lead from the battery to terminal 1 and the negative (-) lead to terminal 2, check that the motor turns clockwise.
- (b) Reverse the polarity, check that the motor turns counterclockwise.  
If operation is not as specified, replace the motor.

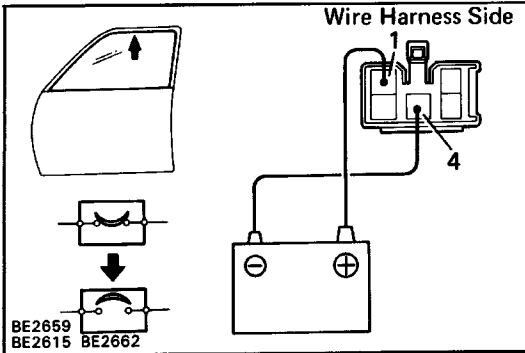
**(Right Side Door Motor/ Circuit Breaker Operation)**

- (a) Disconnect the connector from the power window switch.
- (b) Connect the positive (+) lead from the battery to terminal 1 and negative (-) lead to terminal 4 on the wire harness side connector, and raise the window to full closed position.
- (c) Continue to apply voltage, check that there is a circuit breaker operation noise within approximately 4 to 40 seconds.
- (d) Reverse the polarity, check that the window begins to descend within approximately 60 seconds.  
If operation is not as specified, replace the motor.

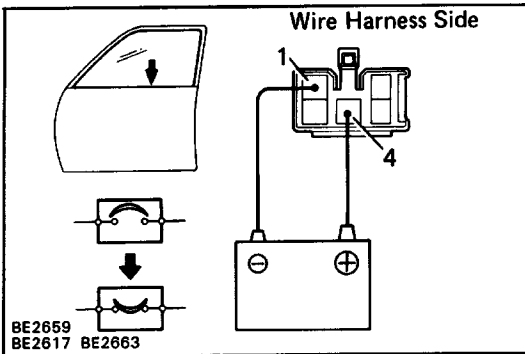
**3. INSPECT DOOR LOCK CONTROL RELAY**

See step 3 of Power Door Lock Control System on page [BE-52](#).



# POWER DOOR LOCK CONTROL SYSTEM Parts Location

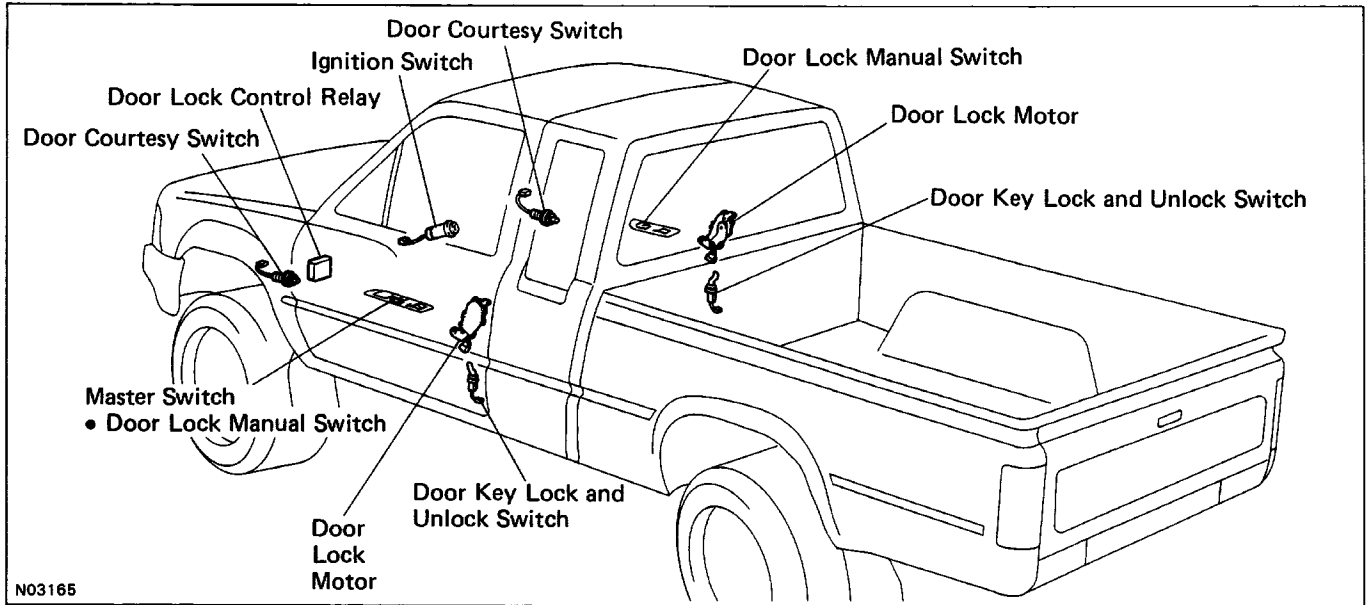

## Wiring and Connector Diagrams

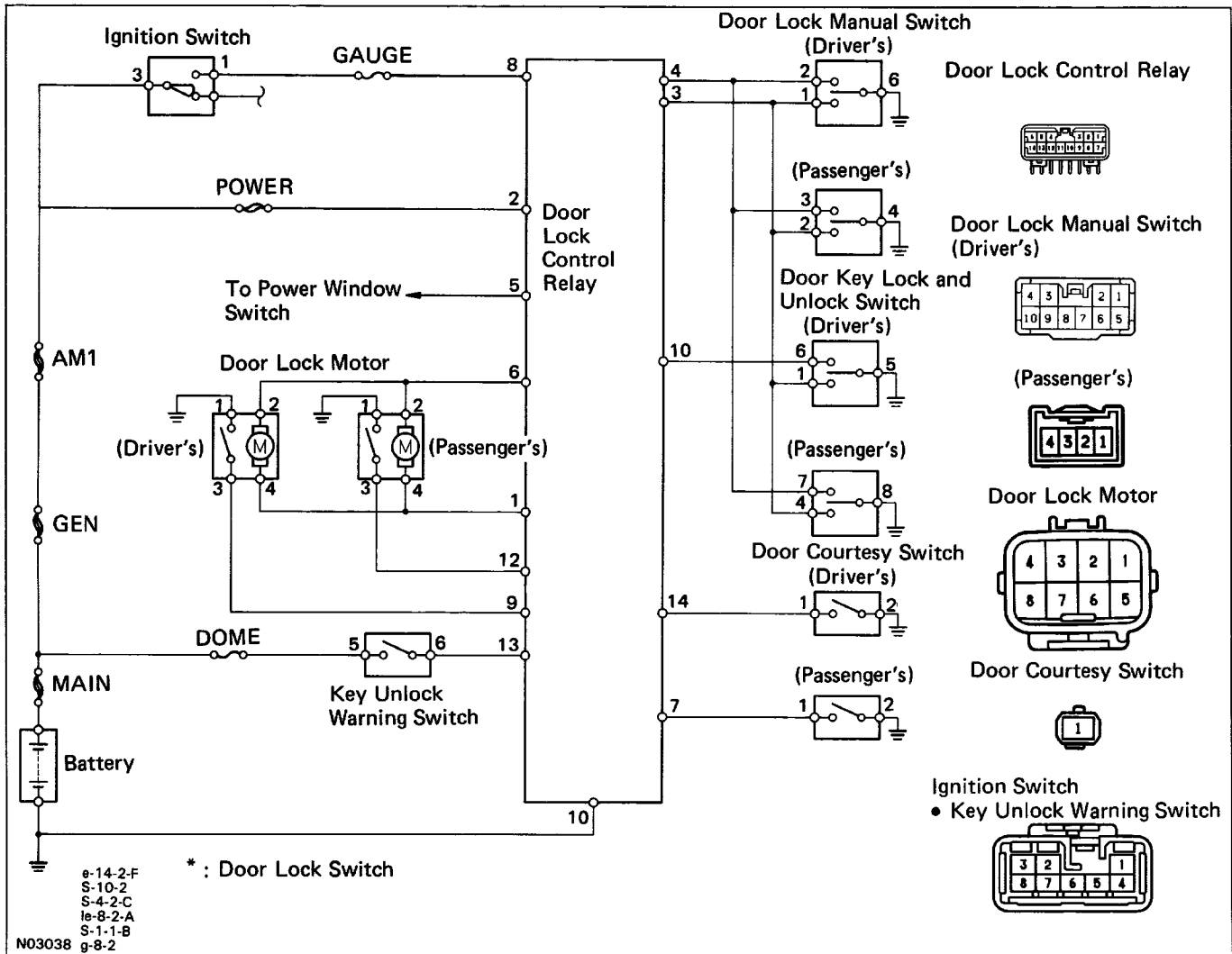

# Troubleshooting

Problem	Possible cause	Remedy	Page
Door lock system does not operate at all	GAUGE fuse blown Door lock solenoid faulty Door lock control relay faulty Wiring or ground faulty	Replace fuse and check for short Check solenoid Check relay Repair as necessary	BE-3 BE-50 BE-51
Door lock system does not operate by manual switch	Door lock manual switch faulty Door lock control relay faulty Wiring or ground faulty	Check switch Check relay Repair as necessary	BE-49 BE-51
Door lock system does not operate by door key	Door key lock and unlock switch faulty Door lock control relay faulty Wiring or ground faulty	Check switch Check relay Repair as necessary	BE-49 BE-51

## Parts Inspection

### 1. INSPECT SWITCHES

(Driver's Door Lock Manual Switch: in Master Switch/ Continuity)

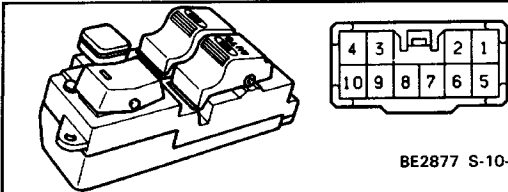
 <p>BE2877 S-10-2</p>	Terminal Switch position	1	2	6
	LOCK		○	○
	OFF			
	UNLOCK	○	○	○

(Passenger's Door Lock Manual Switch/ Continuity)

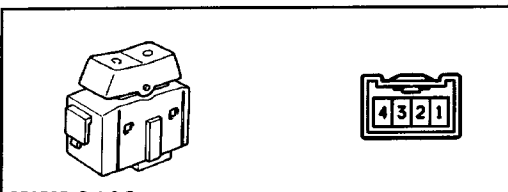
 <p>BE2595 S-4-2-C</p>	Terminal Switch position	2	3	4
	LOCK		○	○
	OFF			
	UNLOCK	○	○	○

(Door Key Lock and Unlock Switch/ Continuity)

 <p>N02426 1e-8-2-A</p>	Terminal Switch position	RH 4	8	7
		LH 1	5	6
	LOCK		○	○
	OFF			
UNLOCK	○	○		

If continuity is not as specified, replace the switch.

(Key Unlock Warning Switch/ Continuity)

See Step I of Key Confine Prevention System on page [BE-9](#).

(Door Courtesy Switch/ Continuity)

See Step of Open Door Warning System on page [BE-41](#).

HINT: Door key lock and unlock switch is built into the front door lock assembly.

## 2. INSPECT DOOR LOCK MOTOR

(Motor Operation)

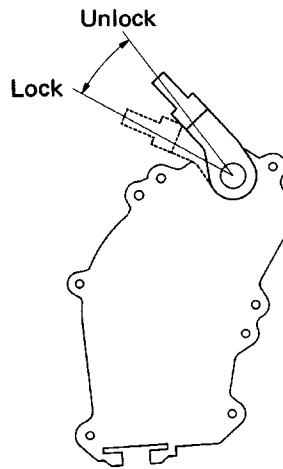

N02426

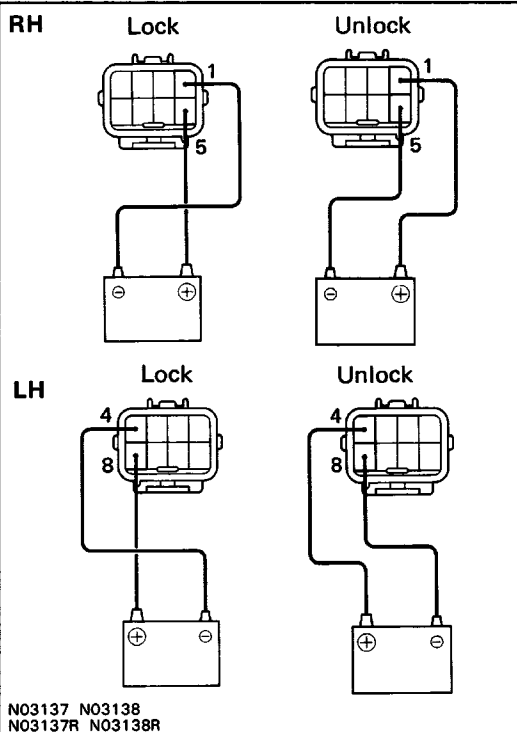

- Connect the positive (+) lead from the battery to terminal 1 and the negative (-) lead to terminal 5, check that the door lock link moves to UNLOCK position.
- Remove the polarity, check that the door lock link move to LOCK position.  
If operation is not as specified, replace the door lock assembly.
- Connect the positive (+) lead from the battery to terminal 4 and the negative (-) lead to terminal 8, check that the door lock link moves to UNLOCK position.
- Remove the polarity, check that the door lock link move to lock position.  
If operation is not as specified, replace the door lock assembly.

Wire Harness Side

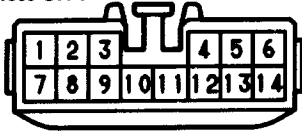

e-14-1-A

### 3. INSPECT DOOR LOCK CONTROL RELAY (Relay Circuit)

Disconnect the connector from the relay and inspect the connector on the wire harness side as shown in the chart.

Check for	Tester connection	Condition	Specified value	
Continuity	3 - Ground	Door lock manual switch or door key lock and unlock switch position	OFF or LOCK	No continuity
			Unlock	Continuity
	4 - Ground	Door lock manual switch or door key lock and unlock switch position	OFF or Unlock	No continuity
			Lock	Continuity
	7 - Ground	Passenger's door courtesy switch position	OFF (Door closed)	No continuity
			ON (Door opened)	Continuity
	9 - Ground	Driver's door lock switch position	Unlock	Continuity
			Lock	No continuity
	11 - Ground	Constant		Continuity
	12 - Ground	Passenger's door lock switch position	Unlock	Continuity
Lock			No continuity	
14 - Ground	Driver's door courtesy switch position	OFF (Door-closed)	No continuity	
		ON (Door opened)	Continuity	
Voltage	2 - Ground	Constant	Battery positive voltage	
	8 - Ground	Ignition switch position	LOCK or ACC	No voltage
			ON	Battery positive voltage
	13 - Ground	Key unlock warning switch position	OFF (Ignition key removed)	No voltage
ON (Ignition key set)			Battery positive voltage	

If circuit is as specified, inspect the door lock signal and key-off power window signal.

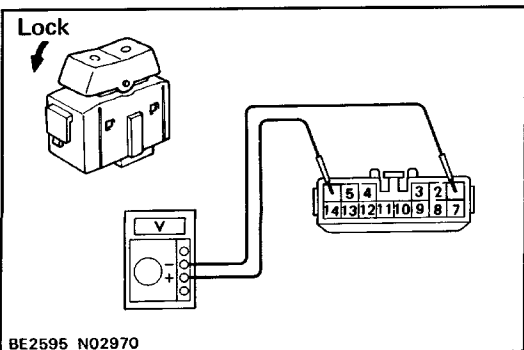
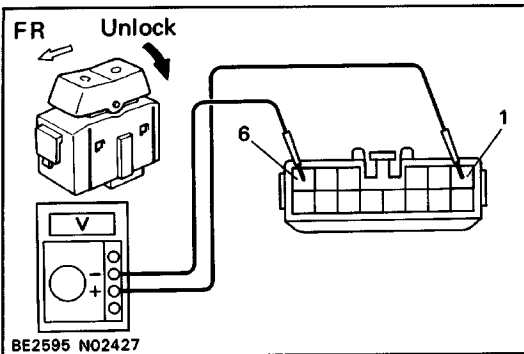

#### (Door Lock Signal)

HINT: When the relay circuit is as specified, inspect the door lock signal.

- Connect the connector to the relay.
- Connect the positive (+) lead from the voltmeter to terminal 1 and negative (-) lead to terminal 6.
- Set the door lock manual switch to UNLOCK, check that the voltage rises from 0 V to battery positive voltage for approximately 0.2 seconds.
- Reverse the polarity of the voltmeter leads.
- Set the door-lock manual switch to LOCK, check that the voltage rises from 0 V to battery positive voltage for approximately 0.2 seconds.

If operation is not as specified, replace the relay.

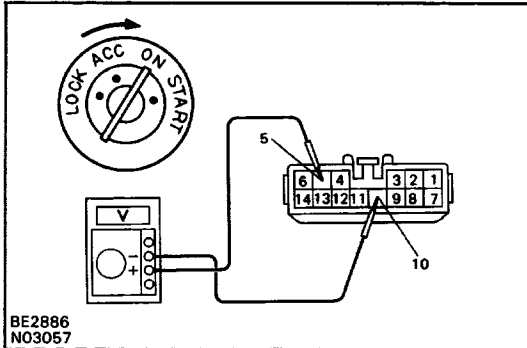
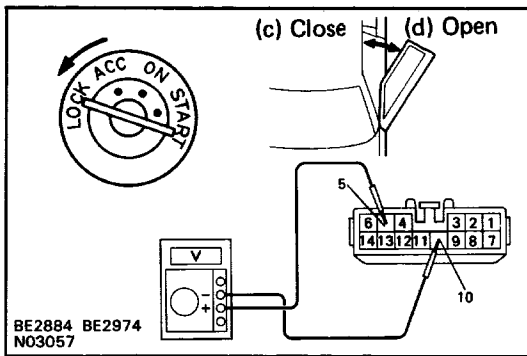

### (Key-Off Power Window Signal)

HINT: When the relay circuit is as specified, inspect the key-off power window signal.

- (a) Connect the connector to the relay.
- (b) Connect the positive (+) lead from the voltmeter to terminal 5 and negative (-) lead to terminal 10.
- (c) Close the door with ignition switch turned to LOCK or ACC, check that the meter needle indicates battery positive voltage.
- (d) Open the door, check that the meter needle indicates 0 V.
- (e) Turn the ignition switch ON, check that the meter needle indicates battery positive voltage again. If operation is not as specified, replace the relay.

# POWER MIRROR CONTROL SYSTEM Parts Location

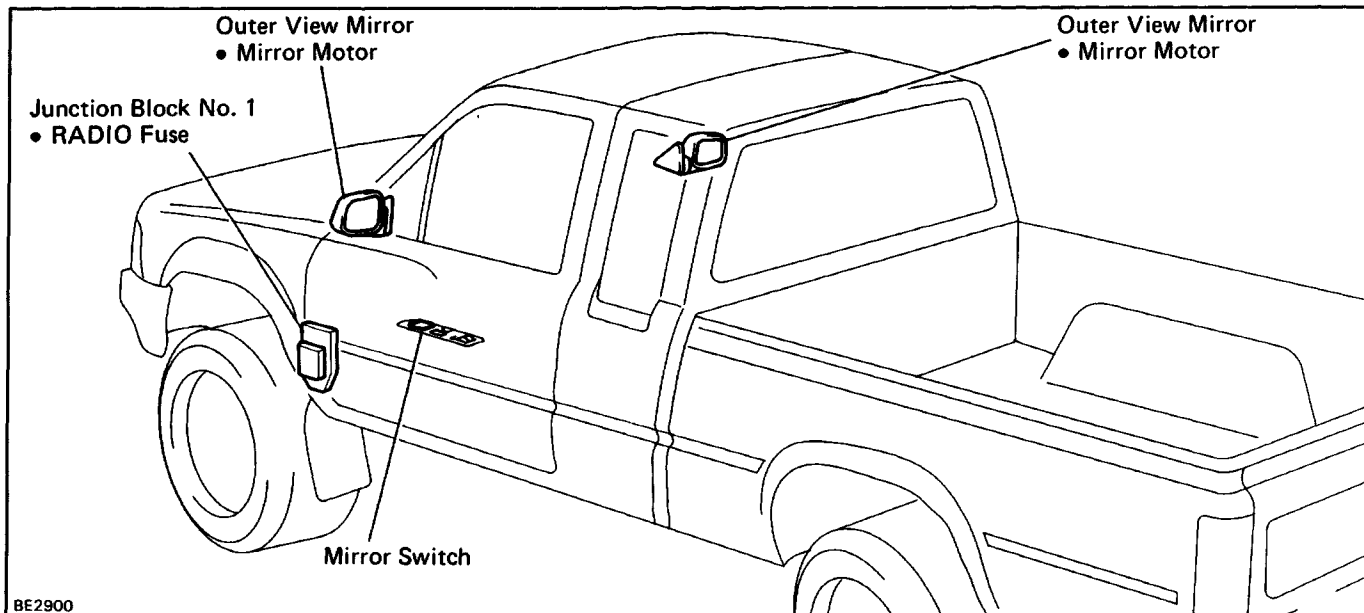

BE2900

## Wiring and Connector Diagrams

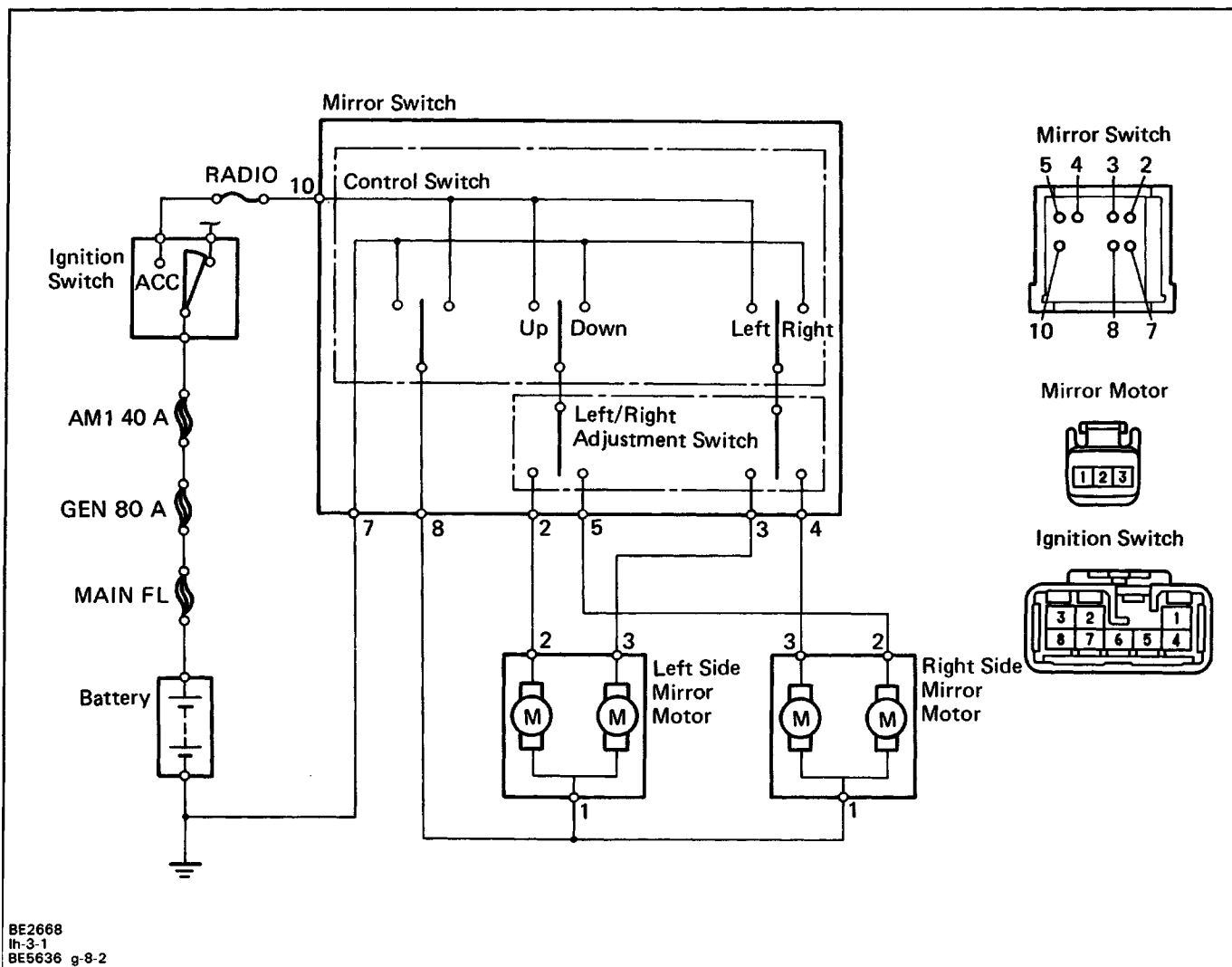

BE2668  
lh-3-1  
BE5636 g-8-2

# Troubleshooting

Problem	Possible cause	Remedy	Page
Remote control mirror system does not operate	RADIO fuse blown  Mirror switch faulty Mirror motor faulty Wiring or ground faulty	Replace fuse and check for short Check switch Check motor Repair as necessary	BE-3  BE-54 BE-55

## Parts Inspection

### 1. INSPECT MIRROR SWITCH (CONTINUITY)

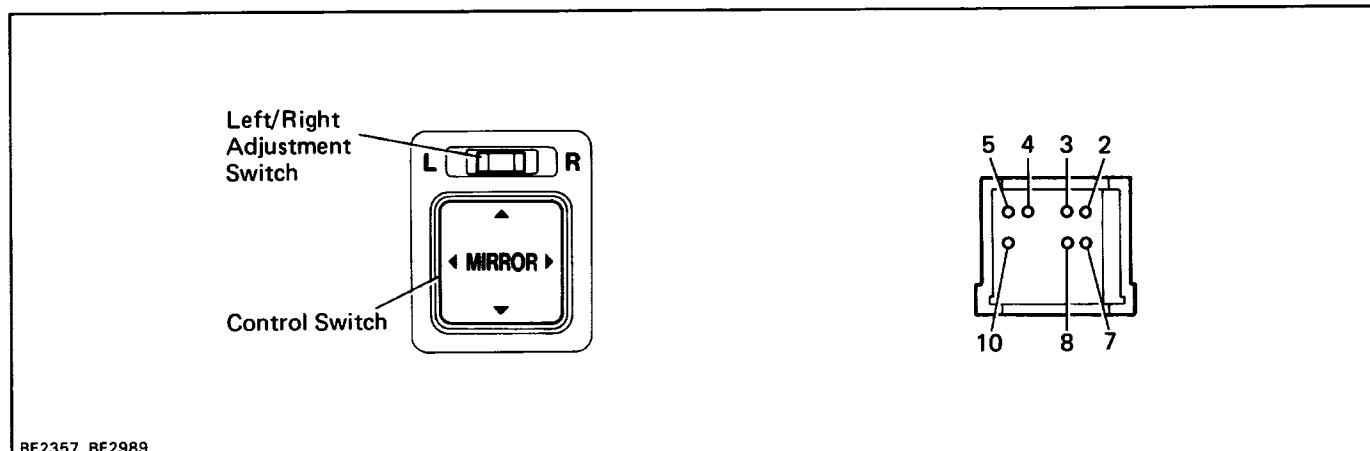

BE2357 BE2989

Left/Right adjustment switch position	LEFT SIDE					OFF			RIGHT SIDE				
Terminal	2	3	7	8	10	7	8	10	4	5	7	8	10
Control switch position													
OFF													
UP	○		○	○	○	○	○			○		○	○
DOWN	○		○	○	○		○	○		○	○	○	○
LEFT		○	○	○	○	○	○		○			○	○
RIGHT		○	○	○	○		○	○	○		○	○	○

If continuity is not as specified, replace the switch.

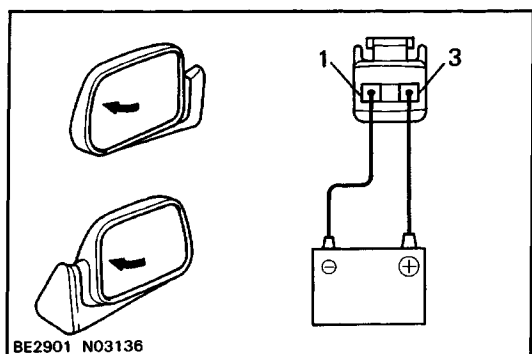

## 2. INSPECT MIRROR MOTOR

- (a) Connect the positive (+) lead from the battery to terminal 3 and negative (-) lead to terminal 1, check that the mirror turns to left side.

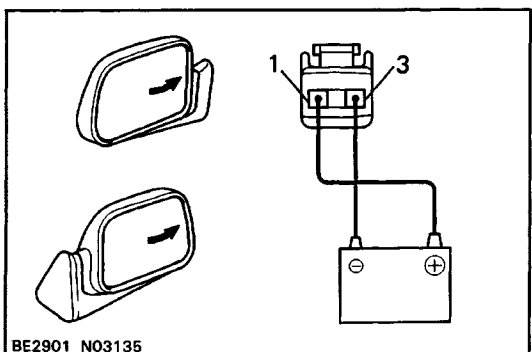

- (b) Reverse the polarity, check that the mirror turns to right side.

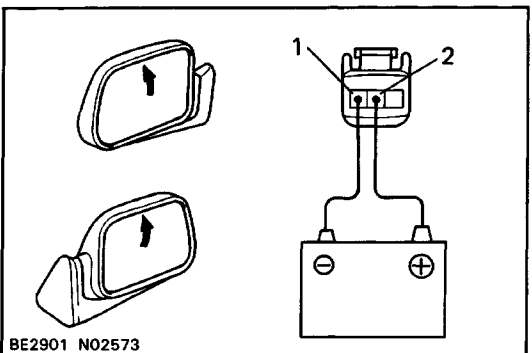

- (c) Connect the positive (+) lead from the battery to terminal 2 and the negative (-) lead to terminal 1, check that the mirror turns upward.

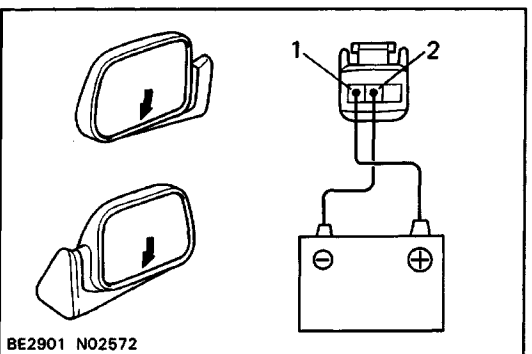

- (d) Reverse the polarity, check that the mirror turns downward.  
If operation is not as specified, replace the mirror assembly.



# CRUISE CONTROL SYSTEM Parts Location

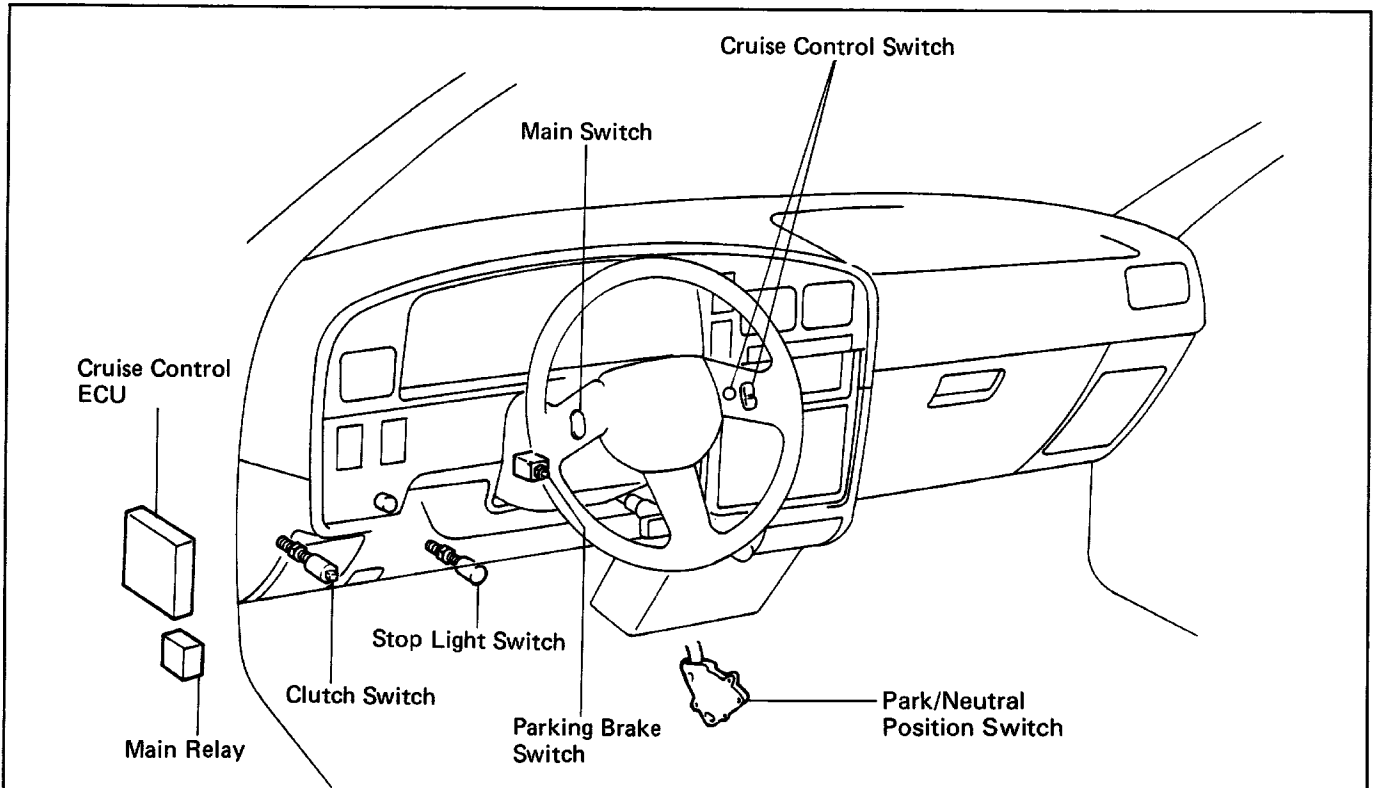

## 3VZ-E ENGINE

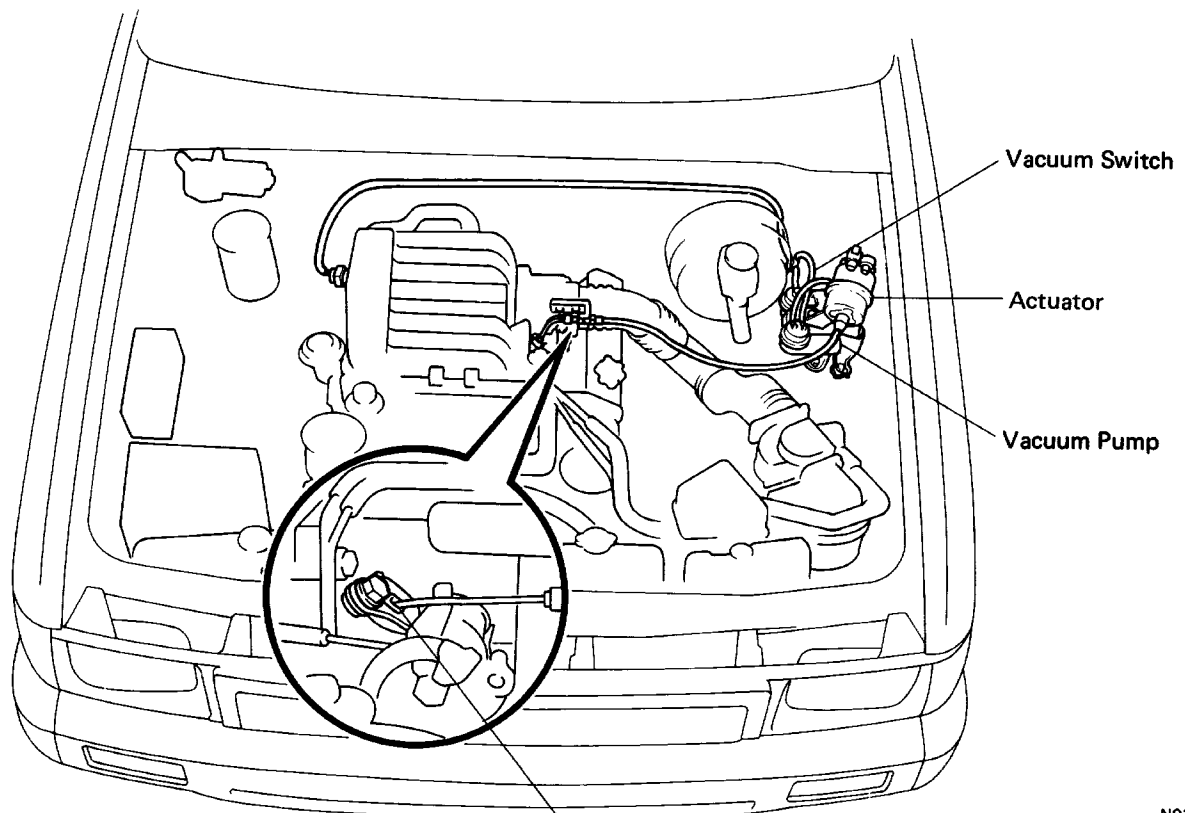

7.8 (80, 69 in.-lbf)

N·m (kgf·cm, ft·lbf) : Specified torque

**22R-E ENGINE**

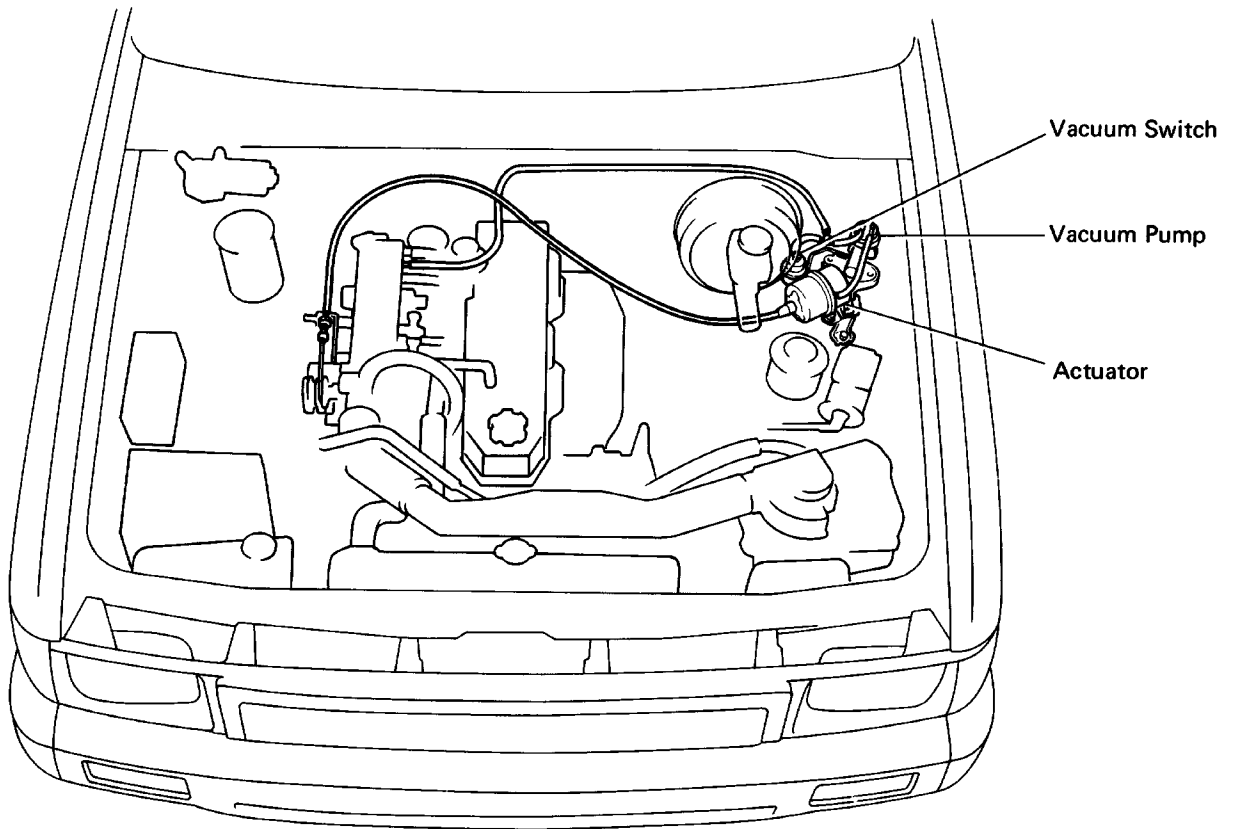

BE3035

# Wiring Diagram

- \*1 RESUME/ACCEL Switch
- \*2 SET/COAST Switch
- \*3 CANCEL Switch

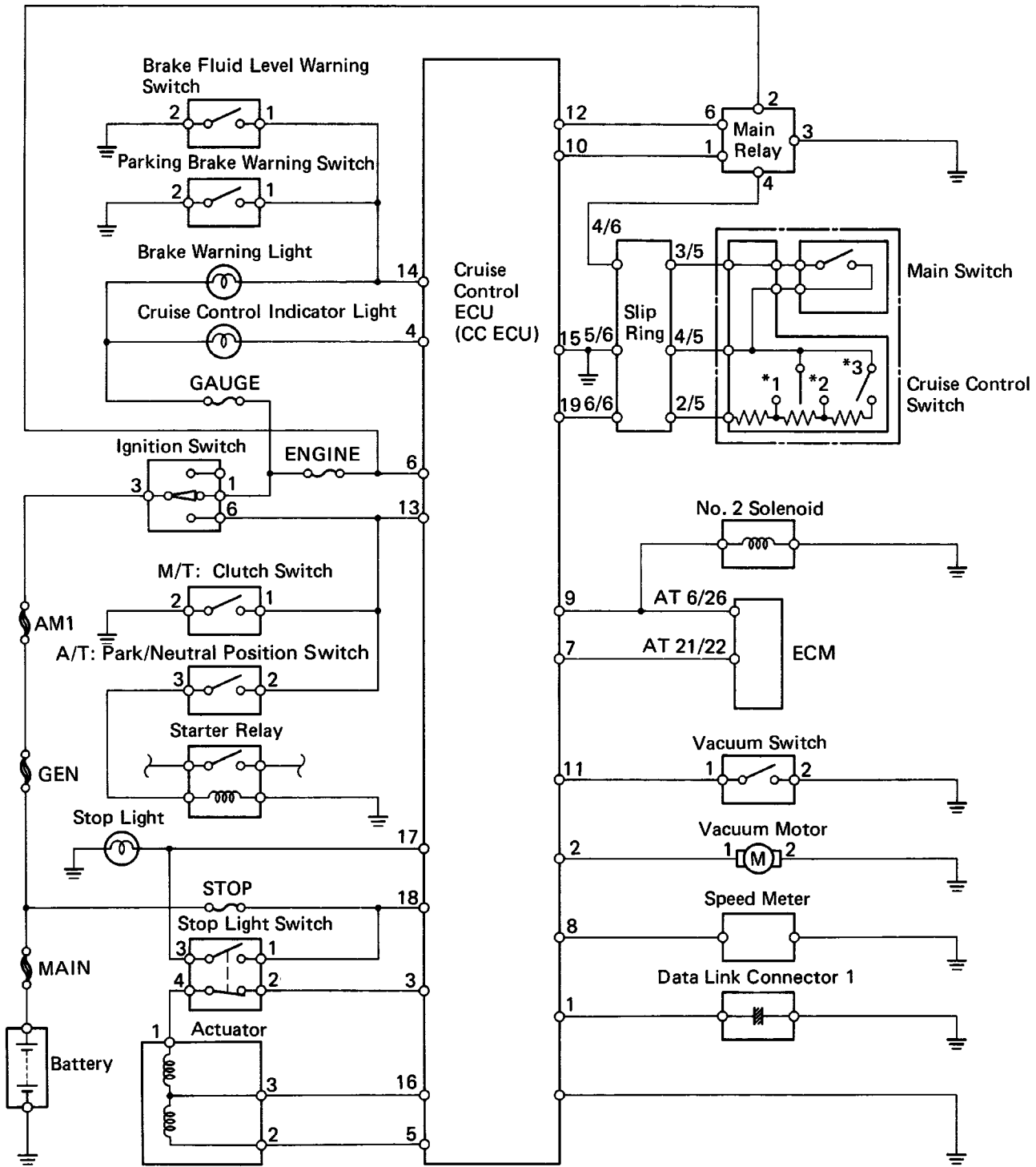

# Connector Diagrams

Cruise Control ECU

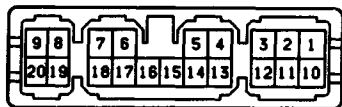

Main Relay



Main Switch



Cruise Control Switch



Slip Ring Speed  
(Control Switch Side)

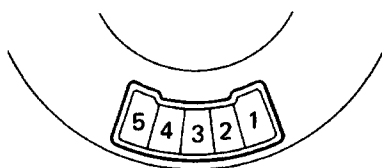

(Wire Harness Side)

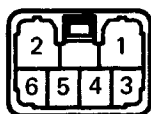

Actuator

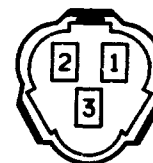

Vacuum Pump



Vacuum Switch

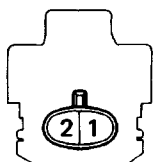

Stop Light Switch

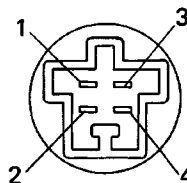

Data Link Connector 1

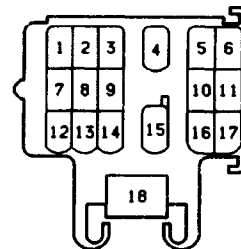

Parking Brake Switch

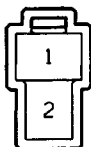

Clutch Switch

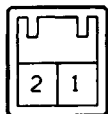

Park/Neutral Position Switch

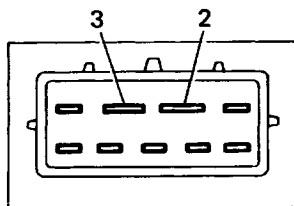

# System Description

## Standby Operation

- When the ignition switch is turned ON (IG), current flows from the battery to terminal 6 of the Cruise Control ECU (hereafter called ECU).
- When the ignition switch is turned ON (IG), current flows from the battery to terminal 2 of the Main Relay.

## Operation

### 1. MAIN SWITCH OPERATION

When the main switch is pushed ON, current flows from terminal 2 of the main relay ∞ terminal 4 ∞ terminal 4/6 of the slip ring–i terminal 3/5–terminal 3/5 ∞ of the cruise control switch (hereafter called SCS)–i terminal 1/2 ∞ terminal 1 of the main switch–terminal 2 ∞/terminal 2/2 of the SCS ∞ terminal 4/5 ∞ terminal 4/5 of the slip ring ∞ terminal 5/6 ∞ ground.

As a result, the main relay turned ON ∞ current flows to terminal 12 of ECU.

After that, current flows through the "CRUISE" indicator light to terminal 4 of the ECU.

Therefore, the main switch remains on and continues to supply current to terminal 12 of the ECU.

### 2. SPEED CONTROL SWITCH OPERATION

The cruise control switch controls the SET, COAST, RESUME, ACCEL and CANCEL functions.

When the each speed control switch is pushed ON, sends a signal (each voltage) from terminal 2/5 of the SCS ∞ terminal 2/5 of the slip ring ∞ terminal 6/6 ∞ terminal 19 of the ECU.

Then, the vehicle speed at the moment the switch (SET position) is released is registered in memory.

### 3. SPEED CONTROL OPERATION

When the vehicle speed is set by the cruise control switch, the ECU send a signal from terminal 3 of the ECU terminal 2 of the stop light switch ∞ terminal 4 ∞ terminal 1 of the actuator (release valve side).

At the same time, the ECU sends a signal from terminal 5 of the ECU ∞ terminal 2 of the actuator (control valve side).

Then, the actuator increases or decreases the throttle valve opening angle in accordance with the signal from the ECU.

### 4. CANCEL OPERATION

The Cruise Control System is provided with several types of the cancel, such as the cruise control switch (CANCEL), the stop light switch, the parking brake switch and the park/neutral position switch (AM or clutch switch (M/T)).

#### (a) Cruise Control Switch (CANCEL)

When the cruise control switch (CANCEL) is pushed ON, sends a cancellation signal from terminal 2/5 of the SCS ∞ terminal 2/5 of the slip ring ∞ terminal 6/6 ∞ terminal 9 of the ECU.

#### (b) Parking Brake Switch

When the parking brake lever is pulled, the parking brake switch turned ON ∞ Sends a cancellation signal (ground voltage) to terminal 14 of the ECU.

#### (c) Park/Neutral Position Switch (A/T)

When the shift lever is set to the "N" or "P" position, the park/neutral position switch turned ON ∞ sends a cancellation signal (ground voltage) to terminal 14 of the ECU.

#### (d) Clutch Switch (M/T)

When the clutch pedal is depressed, the clutch switch is turned ON ∞ sends a cancellation signal (ground voltage) to terminal 13 of the ECU.

#### (e) Stop Light Switch

When the brake pedal is depressed, the SW B of stop light switch is turned OFF ∞ the release valve (in actuator) is opened, and the SW A of stop light switch is turned ON ∞ sends a cancellation signal to terminal 17 of the ECU.

Therefore, the operation of the cruise control system is canceled and the actuator is shut off due to the operation of these switches.





# Diagnosis System

## Output of Diagnostic Trouble Code

### READ DIAGNOSTIC TROUBLE CODE

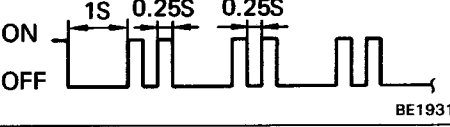
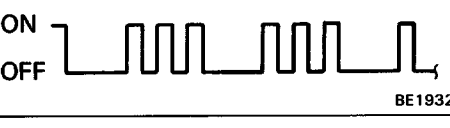
#### (Type A)

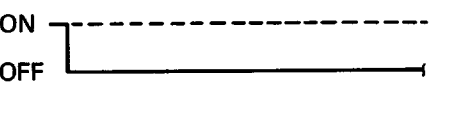
- (a) Turn the ignition switch on.
- (b) Push the SET/COAST switch on, and keep it on.
- (c) Push the main switch on.
- (d) Check that the indicator light "CRUISE" light-on in the combination meter and after 3 seconds check that the indicator light "CRUISE" blinks.
- (e) Turn the SET/COAST switch off.
- (f) Meet the conditions listed below.
- (g) Read the diagnostic trouble code on the indicator light "CRUISE".

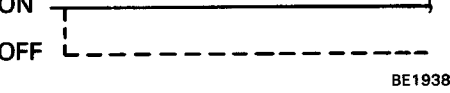
No.	Conditions	Indication code	Diagnosis
1	Push the cruise control switch SET/COAST on.		SET/COAST circuit is normal.
2	Push the cruise control switch RESUME/ACCEL on.		RESUME/ACCEL circuit is normal.
3	Vacuum switch is turned ON.		Vacuum switch circuit is normal.
4	Each cancel switch turned ON. <ul style="list-style-type: none"> <li>• Cruise control switch (to CANCEL)</li> <li>• Stop light switch</li> <li>• Park/Neutral Position switch (to N or P Position)</li> <li>• Clutch switch</li> <li>• Parking brake switch</li> </ul>		Each cancel switch is normal.
5	Drive approx. 40 km/h (25 mph) or over.		Speed sensor circuit is normal.
6	Drive approx. 40 km/h (25 mph) or below.		Speed sensor circuit is normal.

**HINT:**

- Indication codes appear in order from No. 1.
- If there is no indication code, perform diagnosis and inspection. (See page BE-64)
- Indication is stopped, when the MAIN switch is re-pushed.

(Type6)

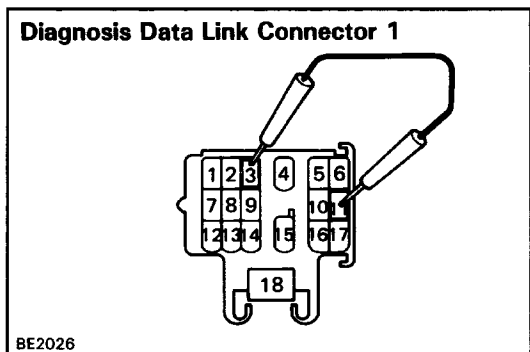

- (a) If while driving with the cruise control on, the system is canceled by a malfunction in either the actuator, speed sensor or cruise control switch circuit, the cruise control indicator light "CRUISE" will blink 5 times.
- (b) While stopping, connect terminals 3 and 11 of the data link connector 1.  
HINT: Should the ignition switch turned off, the diagnostic trouble code will be erased from the computer memory.
- (c) Read the diagnostic trouble code on the indicator light "CRUISE".

	Indication code	Diagnosis
	<p>BE1939</p>	Normal.
11	<p>BE1940</p>	Control valve circuit of actuator is abnormal.
12	<p>BE2711</p>	Release valve circuit of actuator is abnormal.
21	<p>BE1941</p>	Speed sensor circuit is abnormal.
23	<p>BE1943</p>	*Vehicle speed has decreased by 16 km/h (10 mph) or more from the set speed.
32	<p>BE1945</p>	SET/COAST switch signal and RESUME/ACCEL switch signal stay on simultaneously.
34	<p>BE4342</p>	Control switch does not turn off before switching.
<p>* If the set speed can be maintained when the speed control switch is again set at SET/COAST, there is no malfunction .</p>		

When 41 code is indicated, replace the cruise control ECU.

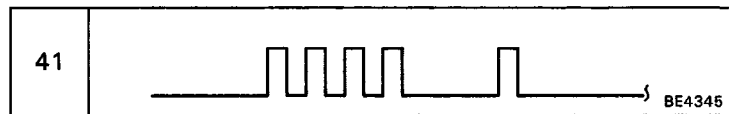

HINT:



- Indication codes appear in order from No. 11
- If there is no indication code, perform diagnosis and inspection. (See page BE-84)

# Troubleshooting

You will find the troubles easier using the table well shown below. In this table, each number shows the priority of causes in troubles. Check each part in order.

Chart No.				C	A	B	E	G, H	F	I	I	D				
Inspection Item				ECU	Actuator	Main Switch	Control Switch	Stop Light Switch	Clutch Switch or Park/ Neutral Position Switch	Parking Brake Switch	Vacuum Switch	Vacuum Pump	Speed Sensor* or Speedometer Cable	Speedometer Cable Function	Others	
Diagnosis Code	Type B	Type A														
Problem	Type B	Type A	ECU	Actuator	Main Switch	Control Switch	Stop Light Switch	Clutch Switch or Park/ Neutral Position Switch	Parking Brake Switch	Vacuum Switch	Vacuum Pump	Speed Sensor* or Speedometer Cable	Speedometer Cable Function	Others		
<ul style="list-style-type: none"> <li>"CRUISE" indicator light blinks 5 time.</li> <li>Cruise control system does not set.</li> <li>Cruise control system does not operate.</li> </ul>	11		2	1												
	12		3	1			2									
	21		2										1			
	23		6	2						5	4	3	1	*2		
	32		2			1										
	Normal	5	OK	8	7	1	2	3	4	5				6	*3	
		NG	2									1				
Setting speed deviated on high or low side.	3	OK	6	5						4	3	2	1			
		NG								1						
Vehicle speed fluctuates when speed control switch turned to SET.			4	3								1	2			
Setting speed does not cancel when brake pedal depressed.	4	OK	3	1			2									
		NG	2				1									
Setting speed does not cancel when parking brake lever pulled.	4	OK	2	1					1							
		NG	2													
Setting speed does not cancel when shifted to "N" position. (A/T)	4	OK	2	1				1								
		NG	2													
Setting speed does not cancel when clutch pedal depressed. (M/T)	4	OK	2	1				1								
		NG	2													
Vehicle speed does not decrease when cruise control switch turned to COAST.	1	OK	3	1									2			
		NG	2			1										
Vehicle speed does not accelerate when cruise control switch turned to ACCEL.	2	OK	3	1									2			
		NG	2			1										
Vehicle speed does not return to memorized speed when control switch turned on RESUME.	2	OK	3	1									2			
		NG	2			1										
Setting speed does not cancel when cruise control switch turned to CANCEL.	4	OK	2	1												
		NG	2			1										
Speed can be set below about 40 km/h (25 mph).	5	OK	2	1									1			
		NG	2													
Cruise control will not disengage even at about 40 km/h (25 mph).	5	OK	2	1									1	2		
		NG	3													
Acceleration response is sluggish when cruise control switch turned to "ACCEL" or "RESUME".	3	OK	4	3							2		1	*2		
		NG								1	2					
": in the Speedometer		Vacuum Hose		*3: Vacuum Hose & Brake Fluid												



# Inspection Chart

## A INSPECTION OF POWER SOURCE CIRCUIT

Turn ignition switch on

Is ENGINE fuse normal?

No  
Replace fuse.  
Is operation normal?

No  

- Short circuit in wire harness between ENGINE fuse and terminal 2 of main relay.
- Inspect main relay. (See page BE-82)

Yes

Yes

Fuse faulty.

### MAIN RELAY

**INSPECT GROUND CONNECTION**  
Disconnect connector from main relay.  
Is there continuity between terminal 3 of main relay and ground?

No  

- Open circuit in wire harness between terminal 3 of main relay and ground.
- Ground faulty.

Yes

**INSPECT POWER SOURCE**  
Is there battery positive voltage between terminal 2 of main relay and ground with ignition switch turned on?

No  
Open circuit in wire harness between ENGINE fuse and terminal 2 of main relay.

Yes

**INSPECT MAIN RELAY OPERATION**  
Is main relay operation normal?  
(See page BE-81)

No  
Main relay faulty.  
Replace main relay. Then recheck system.

Yes

Is there continuity between terminal 6 on wire harness side connector and ground?

Yes  
Short circuit in wire harness between terminals 6 of main relay and 12 of CC ECU.

No

Is there continuity between terminal 1 on wire harness side connector and ground?

Yes  
Short circuit in wire harness between terminals 1 of main relay and 10 of CC ECU.

No

CONTINUED ON NEXT PAGE

CONTINUED FROM PREVIOUS PAGE

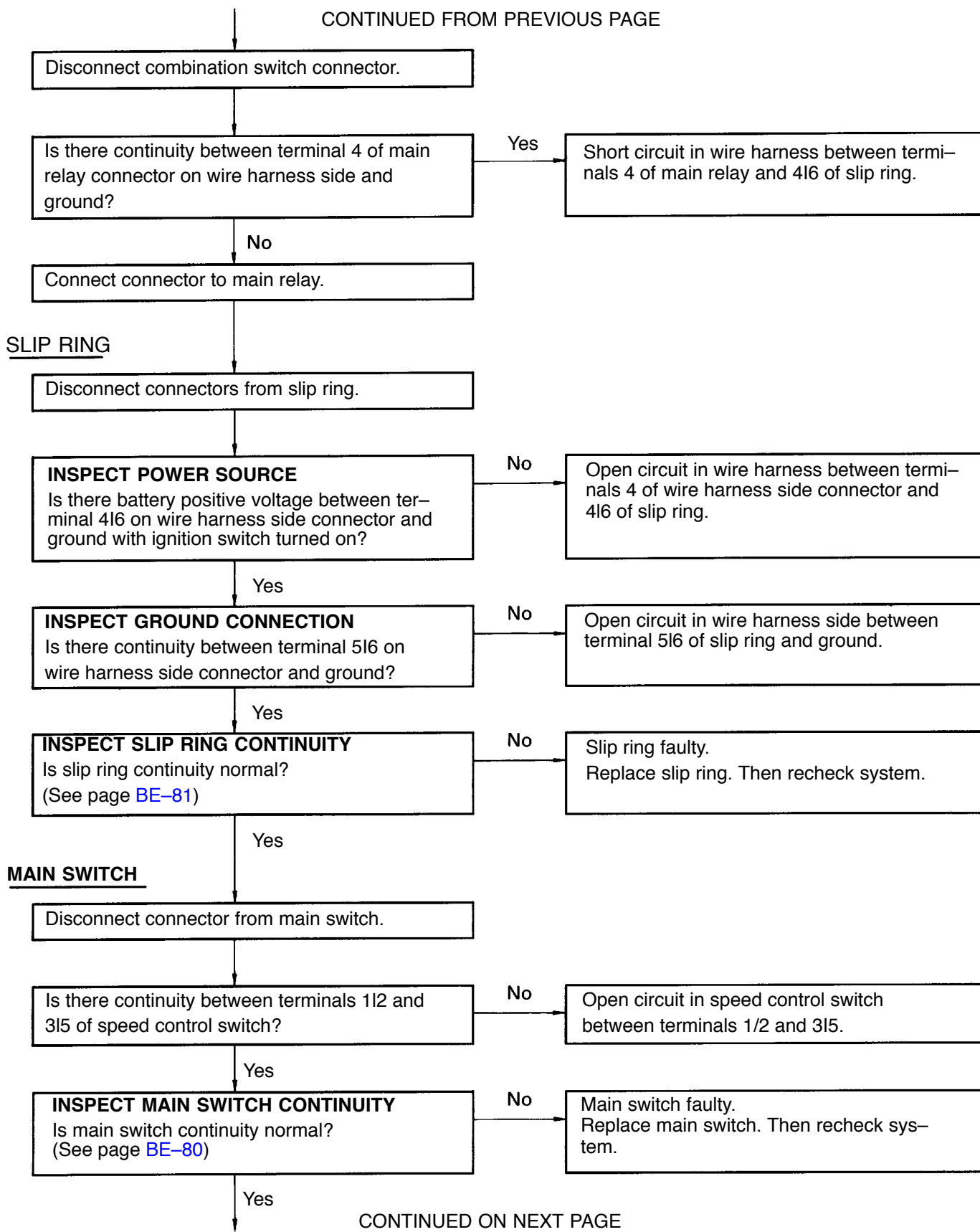

CONTINUED ON NEXT PAGE

CONTINUED FROM PREVIOUS PAGE

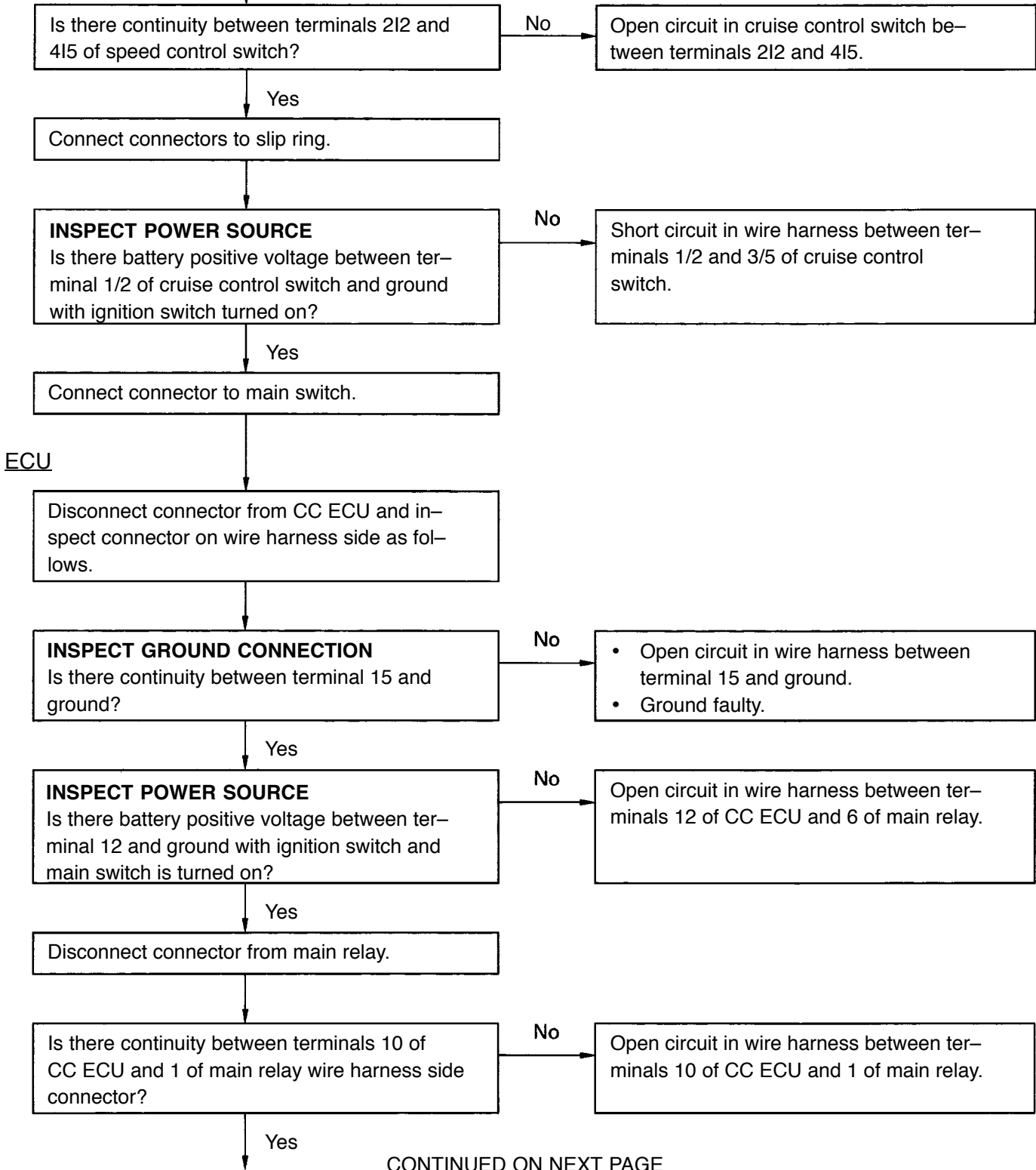

CONTINUED ON PREVIOUS PAGE

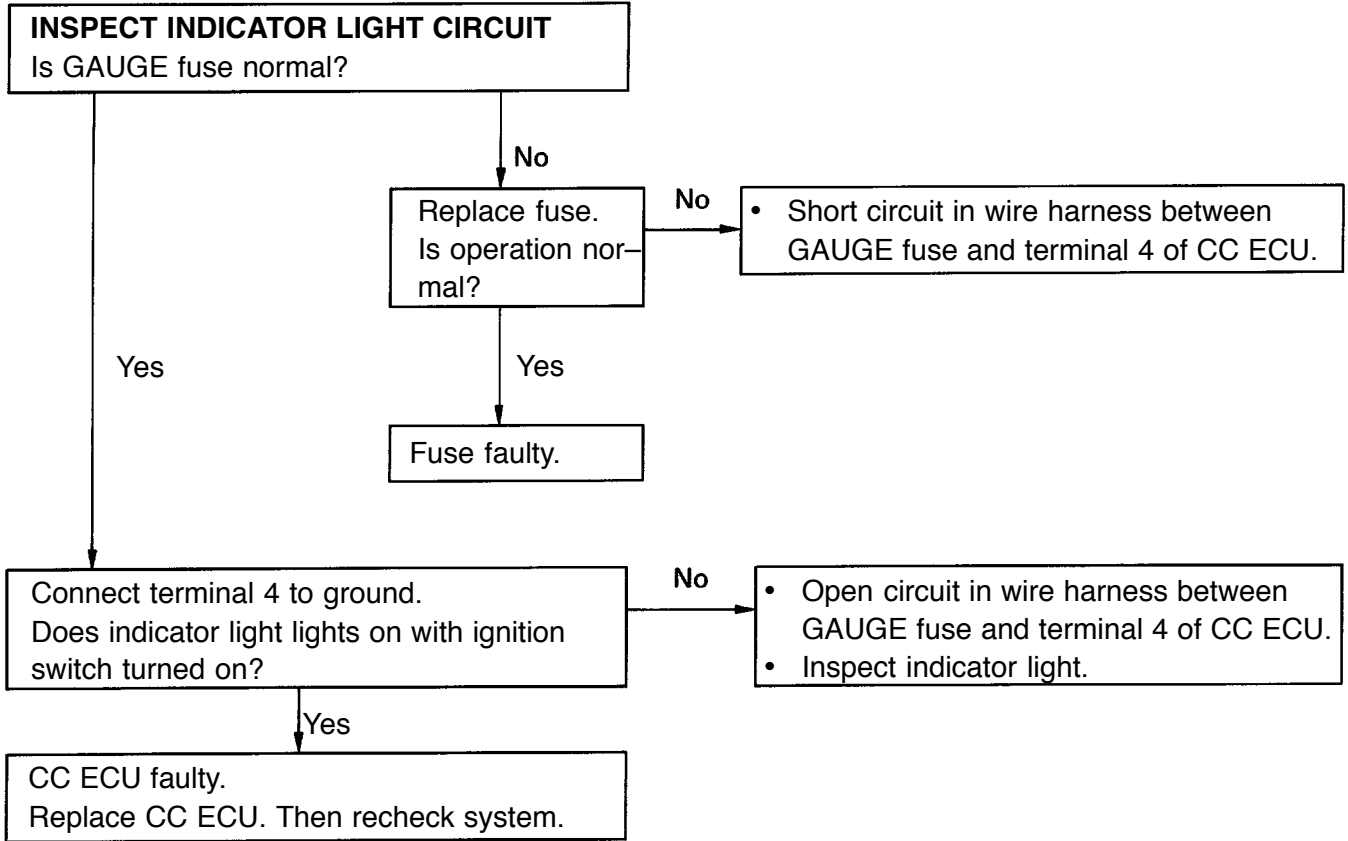

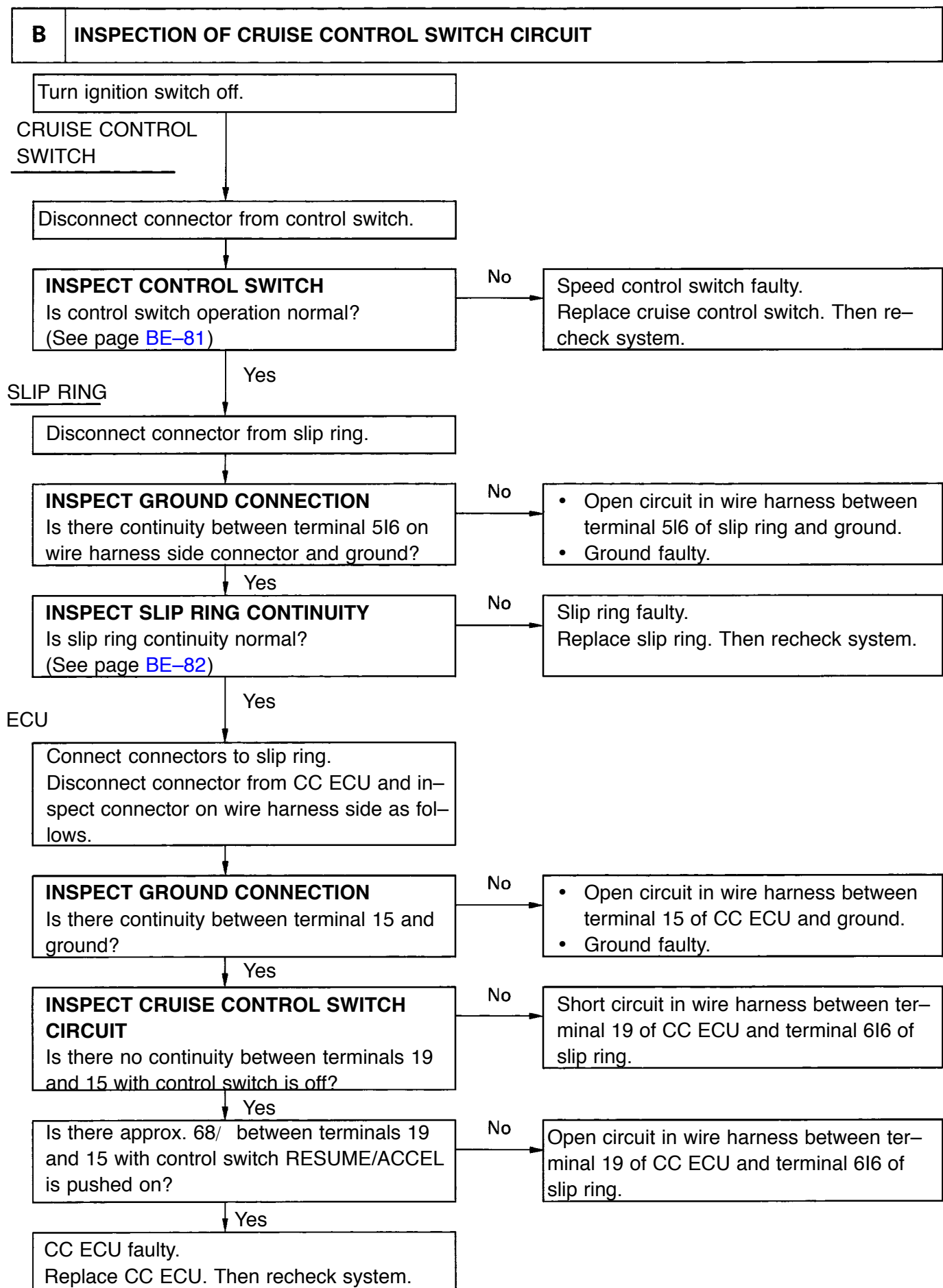

**C INSPECTION OF ACTUATOR CIRCUIT**

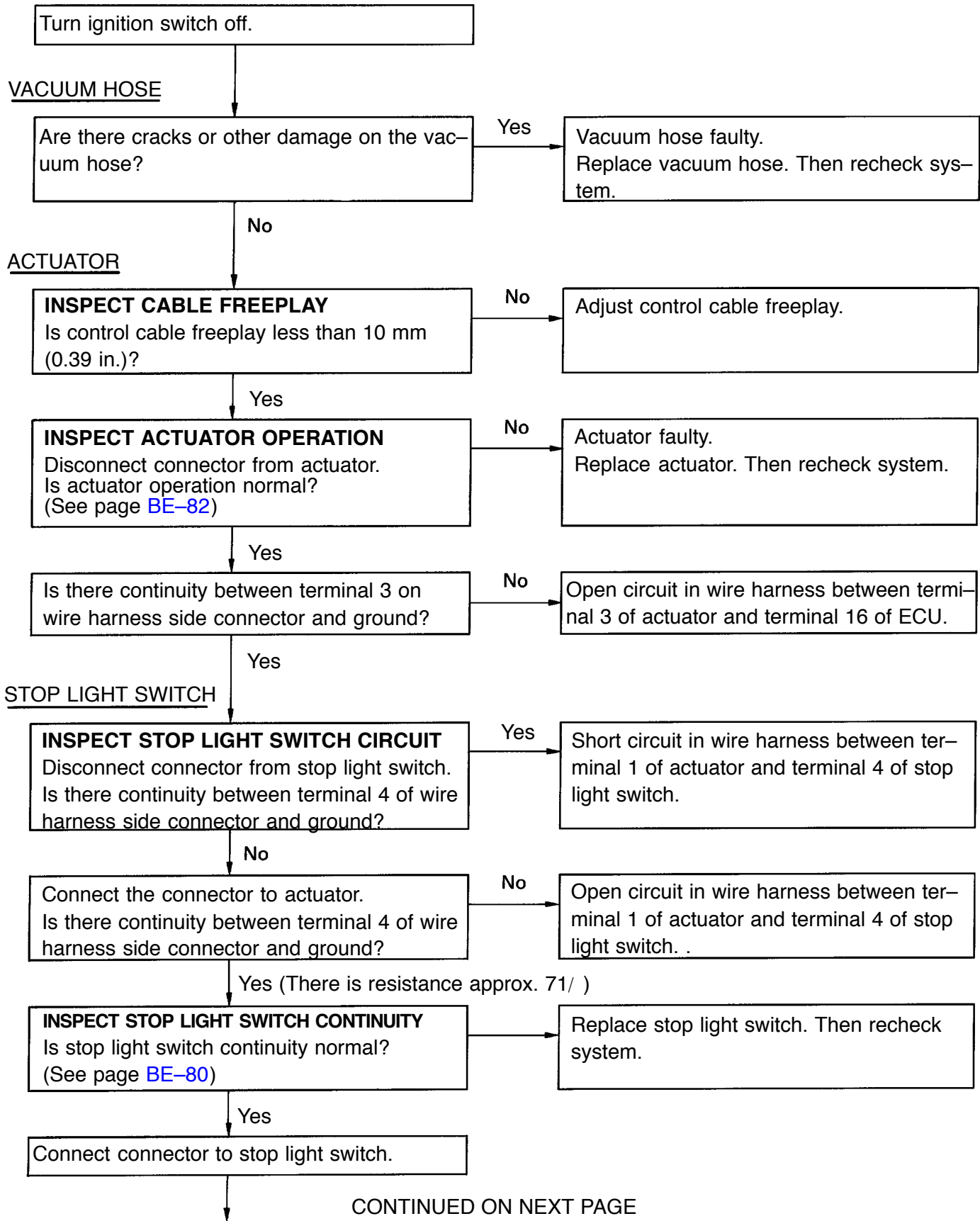

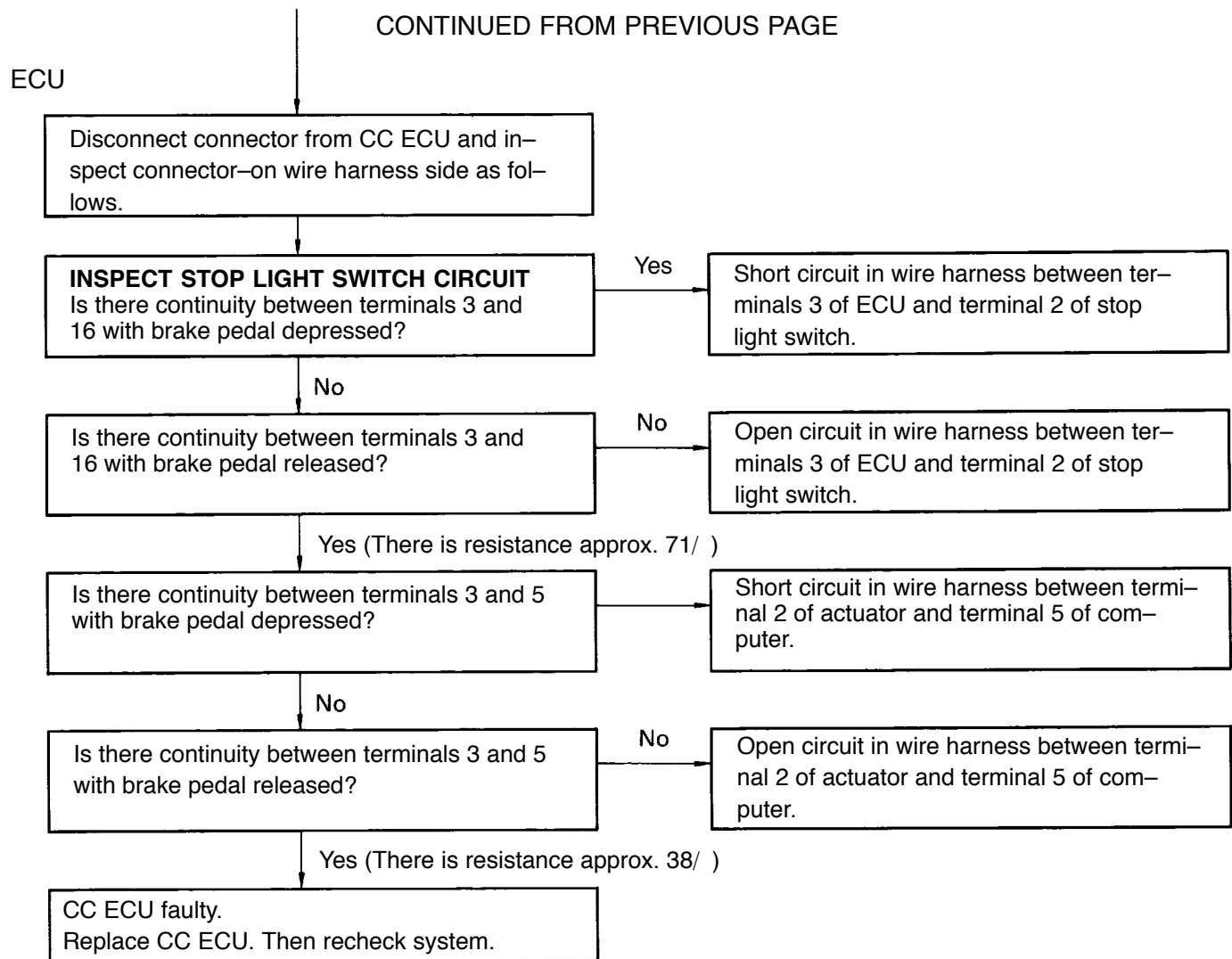

**D INSPECTION OF SPEED SENSOR CIRCUIT**

SPEED METER CABLE

**INSPECT SPEED METER CABLE**  
Does not meter fluctuate when driving at a steady speed?

Yes → Meter cable faulty.  
Replace meter cable. Then recheck system.

No  
Turn ignition switch off.

SPEED SENSOR

Disconnect connector from combination meter.

**INSPECT GROUND CONNECTION**  
Is there continuity between terminal 6 of wire harness side connector and ground?

No →

- Open circuit in wire harness between terminal B of combination meter and ground.
- Ground faulty.

Yes  
**INSPECT SPEED SENSOR OPERATION**  
Is there sensor operation normal?  
(See page BE-33).

No → Speed sensor faulty.  
Replace speed sensor. Then recheck system.

Yes  
Connect connectors to combination meter.

ECU

Disconnect connector from CC ECU and inspect connector on wire harness side as follows.  
Turn ignition switch on.

**INSPECT SPEED SENSOR CIRCUIT**  
Does the voltage between terminal 8 and ground change repeatedly from 0V to approx. 5V or more when speedometer shaft is turned?

No → Open or short circuit in wire harness between terminal 8 of CC ECU and terminal A of combination meter.

Yes  
CC ECU faulty.  
Replace CC ECU. Then recheck system.



## E INSPECTION OF STOP LIGHT SWITCH CIRCUIT

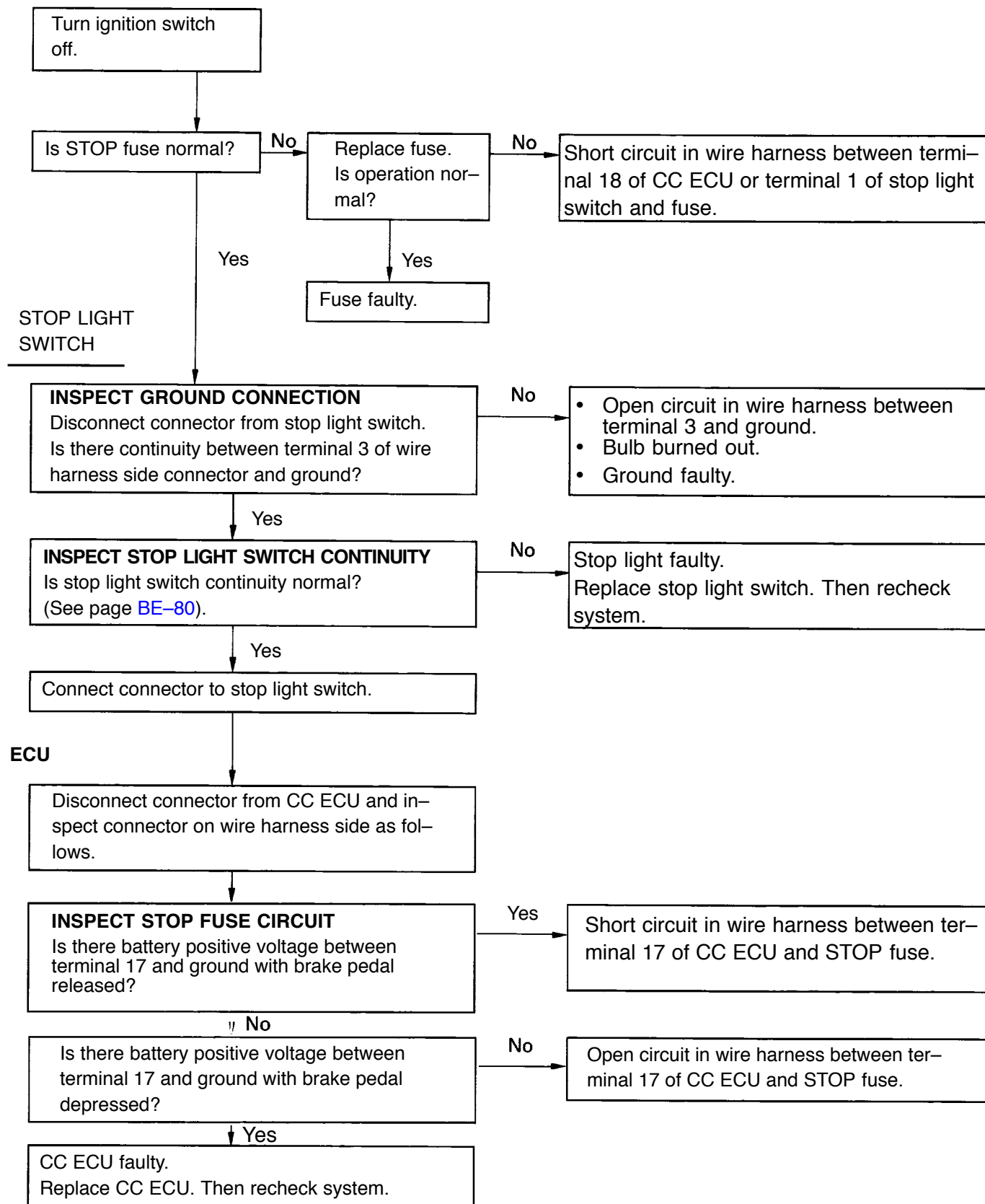

## F INSPECTION OF PARKING BRAKE SWITCH CIRCUIT

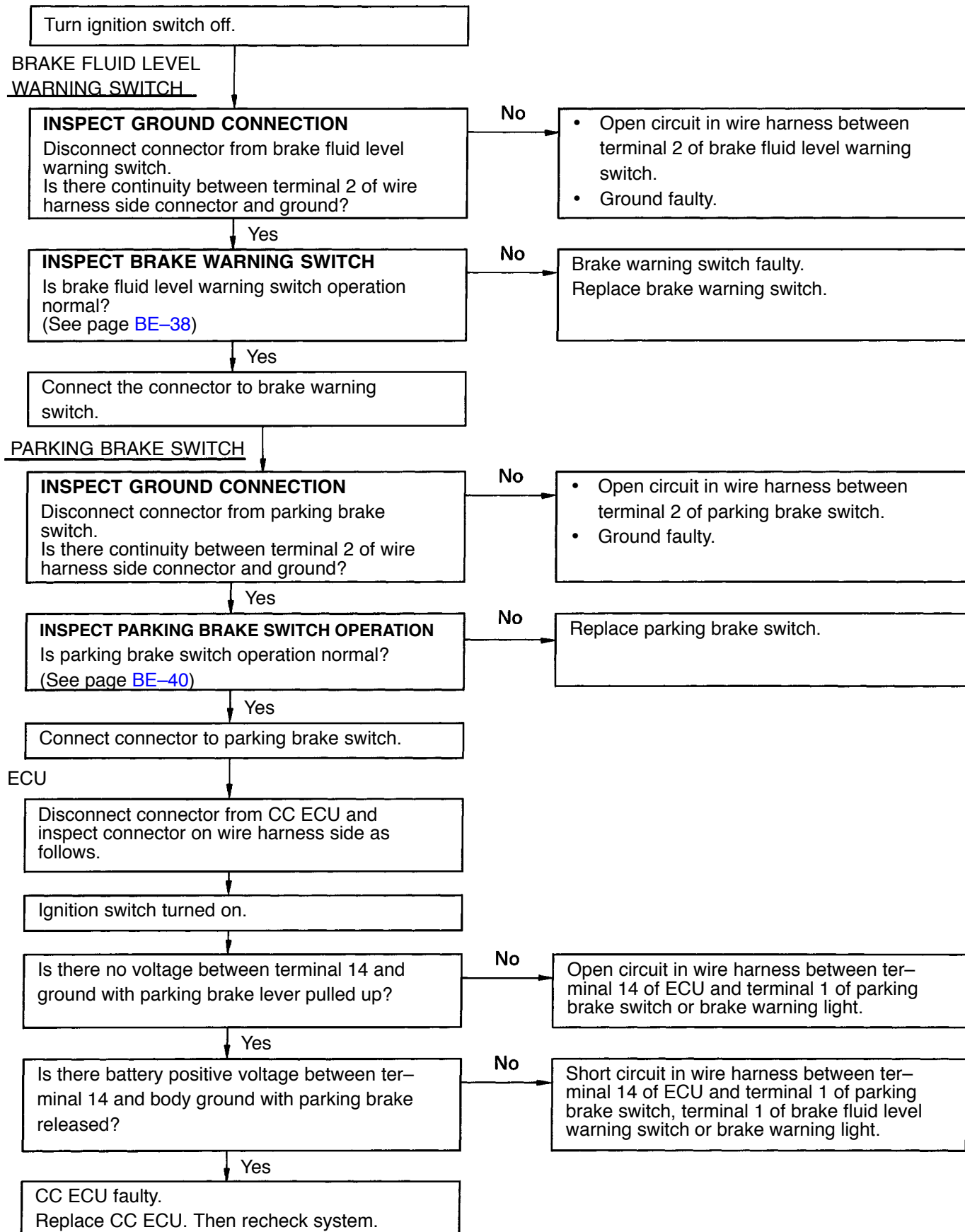

**G INSPECTION OF CLUTCH SWITCH CIRCUIT**

Turn ignition switch off.

**CLUTCH SWITCH****INSPECT GROUND CONNECTION**Disconnect connector from clutch switch.  
Is there continuity between terminal 2 of wire harness side connector and ground?

No

Open circuit in wire harness between terminal 2 of the clutch switch and ground.

Yes

**INSPECT CLUTCH SWITCH CONTINUITY**Is clutch switch continuity normal?  
(See page [BE-81](#))

No

Replace clutch switch.

Yes

Connect connector to clutch switch.

**ECU**

Disconnect connector from CC ECU and inspect connector on wire harness side as follows.

**INSPECT CLUTCH SWITCH CIRCUIT**

Is there continuity between terminal 13 and ground when clutch pedal is depressed?

No

Open circuit in wire harness between terminal 13 of ECU and terminal 1 of clutch switch.

Yes

CC ECU faulty.  
Replace CC ECU. Then recheck system.

# H INSPECTION OF PARK/NEUTRAL POSITION SWITCH CIRCUIT

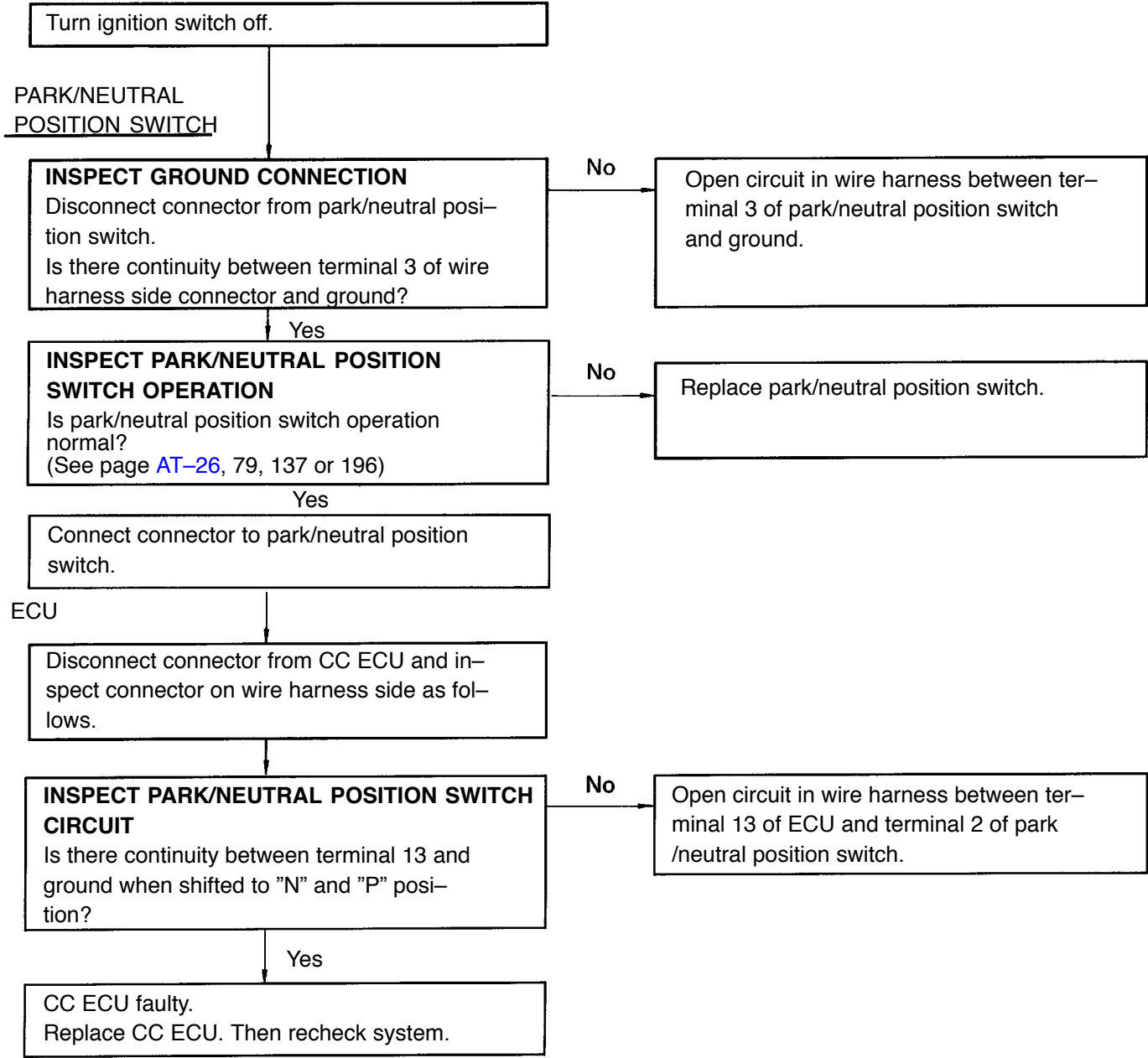

## INSPECTION OF VACUUM CIRCUIT

Turn ignition switch off.

### VACUUM HOSE

Are there cracks or other damage on the vacuum hose?

Yes

Replace vacuum hose.

No

### VACUUM SWITCH

**INSPECT VACUUM SWITCH CIRCUIT**  
Disconnect connector from vacuum switch.  
Is there continuity terminal 2 of vacuum switch and ground?

No

- Open circuit in wire harness between terminal 2 of vacuum switch and ground.
- Ground faulty.

Yes

**INSPECT VACUUM SWITCH OPERATION**  
Is vacuum switch normal?  
(See page [BE-82](#))

No

Replace vacuum switch.

Yes

### VACUUM PUMP

**INSPECT GROUND CONNECTION**  
Disconnect connector from vacuum pump.  
Is there continuity between terminal 2 of wire harness side connector and ground?

No

- Open circuit in wire harness between terminal 2 of vacuum pump and ground.
- Ground faulty.

Yes

**INSPECT VACUUM PUMP OPERATION**  
Is vacuum pump operation normal?  
(See page [BE-82](#))

No

Replace vacuum pump.

Yes

Connect connector to vacuum switch and pump.

CONTINUED ON NEXT PAGE

CONTINUED FROM PREVIOUS PAGE

ECU

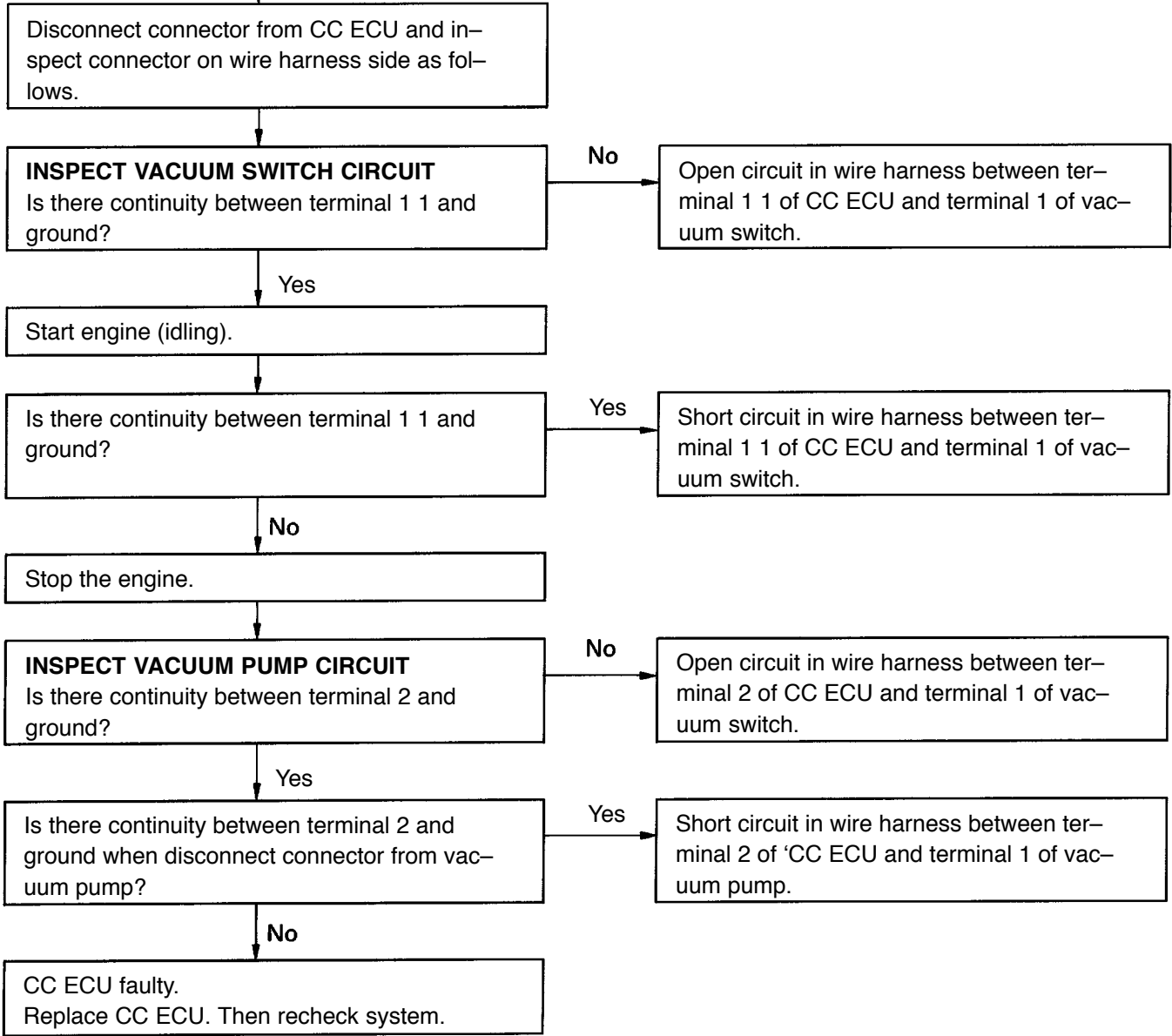

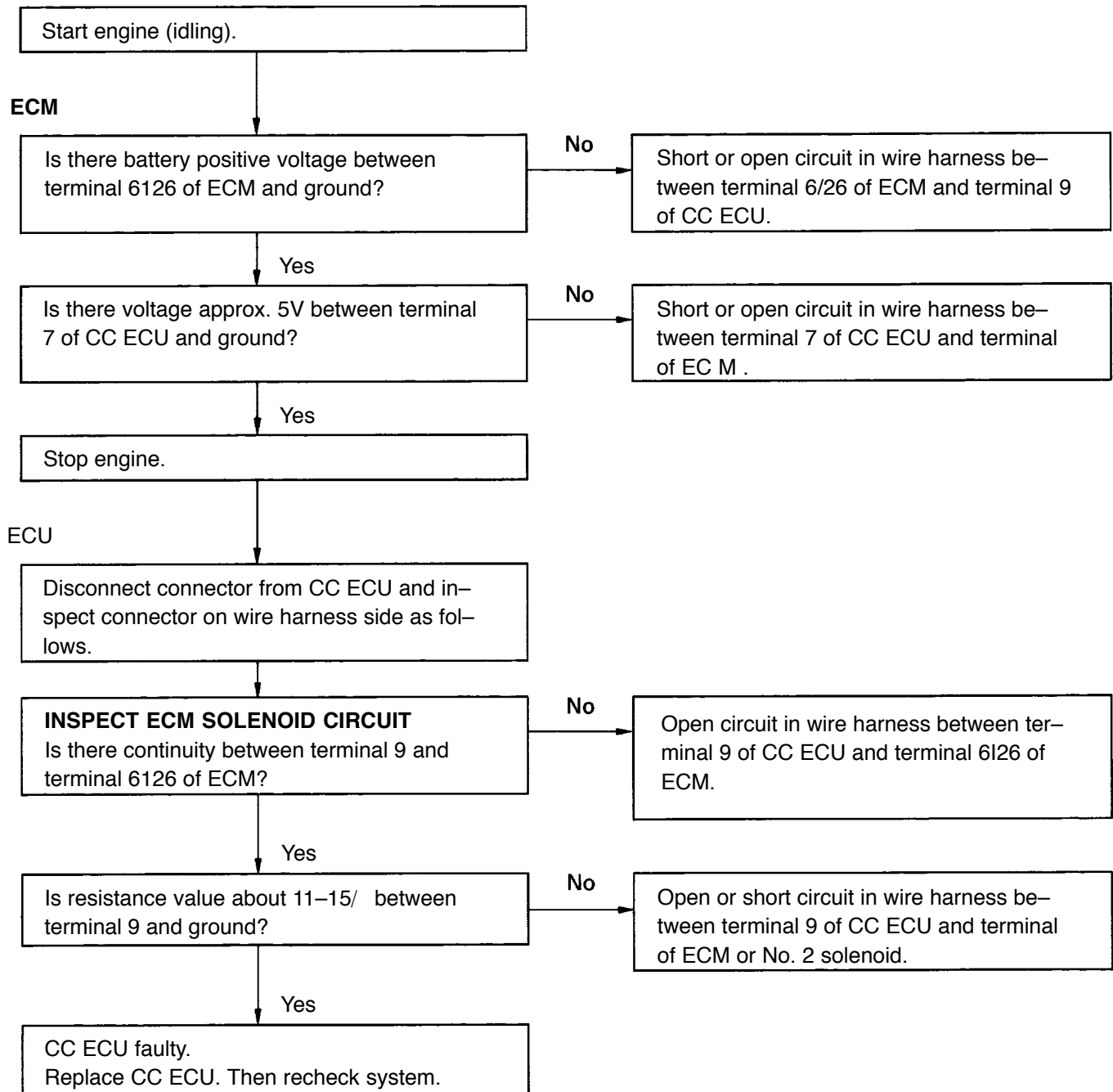
**J INSPECTION OF ECM SOLENOID CIRCUIT**

## Wire Harness Side

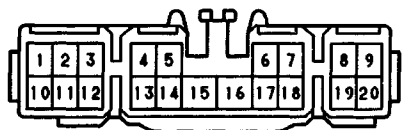

e-20-1

## Cruise Control ECU Circuit Inspection of ECU Circuit

Disconnect the connector from the ECU and inspect the connector on the wire harness side as shown below.

Connection or Measure item	Check for	Tester Connection	Condition	Specified valve	
Data Link Connector 2	Continuity	1 - Ground	Short terminals between "Te" and "E1"	Continuity	
			Released	No continuity	
Vacuum pump		2 - Ground	Constant	Continuity *1	
Speed sensor (in combination meter)		8 - Ground	Vehicle moving slowly	1 pulse each 40 cm approx. (15.75 in.)	
Vacuum switch		11 - Ground	Vacuum	No vacuum	Continuity
				More than 70 + 30 mmHg 6.69 f 1.18 in. Hg 22.66 + 4.0 kPa	No continuity
Park/Neutral Position switch (A/T)		13 - Ground	Shift position	"N" or "P" position D, .2D, DpD or "R" position	Continuity No continuity
Clutch switch (M/T)		13 - Ground	Clutch pedal position	Depressed	Continuity
				Released	No continuity
Parking brake switch		14 - Ground	Parking brake lever position	Pulled	Continuity
	Released			No continuity	
Body ground	15 - Ground	Constant	Continuity		
Stop light switch	17 - 18	Brake pedal position	Depressed	Continuity *1	
			Released	No continuity	
CANCEL switch	Resistance	19 - Ground	CANCEL switch is pushed	Approx. 4180	
			Released	No continuity	
RESUME/ACCEL switch		19 - Ground	Cruise control switch position	RESUME/ACCEL switch is pushed	Approx. 68/
				Released	No continuity
SET/COAST switch		19 - Ground		SET/COAST switch is pushed	Approx. 1980
				Released	No continuity
Stop light switch and actuator (release valve)		3 - 16	Brake pedal position	Depressed	No continuity
			Released	Approx. 71/	
Actuator (control valve)		5 - 16	Constant	Approx. 380	
No. 2 solenoid valve		9 - Ground	Constant	less than 1511	
GAUGE fuse and indicator light	Voltage	4 - Ground	Ignition switch position	ON	Battery positive voltage
				LOCK, ACC	No voltage
ENGINE fuse		6 - Ground	Ignition switch position	ON	Battery positive voltage
					LOCK, ACC
O/D circuit		7 - Ground	Ignition SW position	ON	Approx. 5V or more
					LOCK or ACC
ENGINE fuse, main switch and main relay		10 - Ground	Ignition switch ON and MAIN switch position	ON	less than 0.3 V
					OFF
		12 - Ground	Ignition switch ON and MAIN switch position	ON	Battery positive voltage
					OFF

\* 1 There is resistance in the circuit.

If circuit is as specified, replace the ECU.



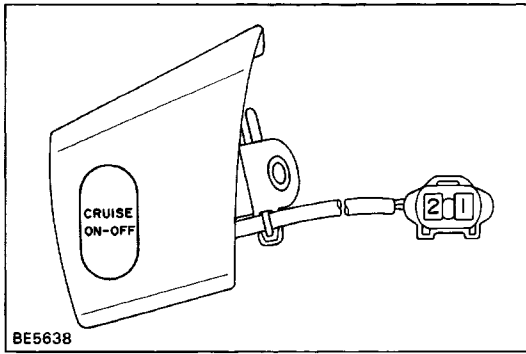

## Parts Inspection

### 1. INSPECT SWITCHES (Main Switch/Continuity)

Terminal Switch position	1	2
OFF		
ON	○	○

If continuity is not as specified, replace the switch.  
(Cruise Control Switch /Continuity)

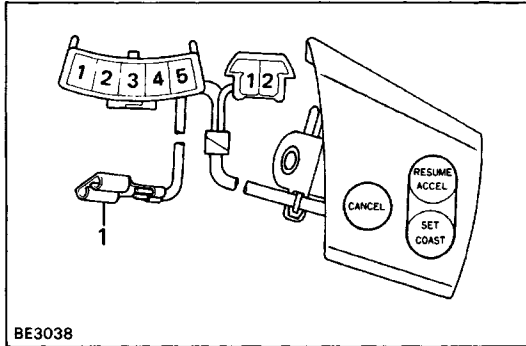

Terminal Condition	1/2	2/2	3/5	4/5
Constant	○	○	○	○

If continuity is not as specified, replace the switch.  
(Cruise Control Switch/Resistance)

Measure the resistance value between terminals 2/5 and 4/5 or 2/12.

Switch position	RESISTANCE ( / )
OFF	No continuity
RESUME/ACCEL	Approx. 68
SET/COAST	Approx. 198
CANCEL	Approx. 418

If resistance value is not as specified, replace the switch.

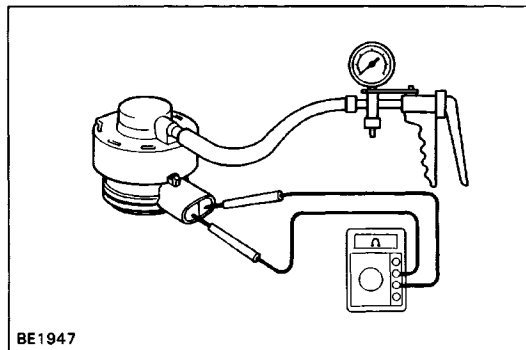

### (Vacuum Switch /Operation)

- (a) Check that there is continuity between terminals with no vacuum.
- (b) Check that there is no continuity between terminals with a vacuum of  $170 \pm 30\text{mmHg}$  ( $6.69 \pm 1.18$  in. Hg,  $22.66 \pm 4.00$  kPa ) or above.

If operation is not as specified, replace the switch.

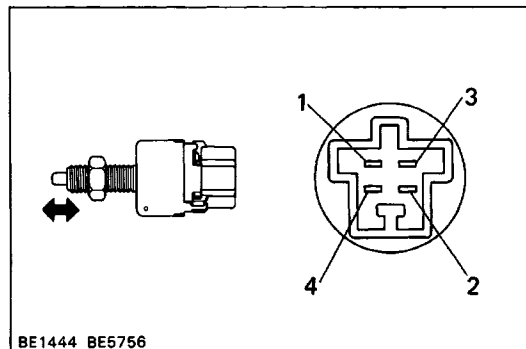

### (Stop Light Switch /Continuity)

Inspect the switch continuity between terminals.

Terminals Switch position	1	2	3	4
Switch pin free (Brake pedal depressed)	○	○	○	
Switch pin pushed in (Brake pedal released)		○	○	○

If continuity is not as specified, replace the switch.

(Clutch Switch /Continuity)  
 Inspect the switch continuity between terminals.

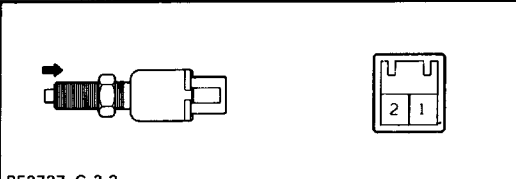
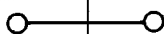
 <p>BE2737 G-2-2</p>	Terminal	1	2
	Condition		
	Switch pin free (Clutch pedal depressed)		
Switch pin pushed in (Clutch pedal released)			

If continuity is not as specified, replace the switch.

**(Brake Fluid Level Warning Switch/Operation)**

See step 2 on page BE-39.

**(Parking Brake Switch/Operation)**

See step 2 on page BE-40.

**(Park/Neutral Position Switch /Operation)**

See pages AT-26, 79, 137 or 196.

**2. INSPECT SPEED SENSOR**

See step 2 on page BE-34.

**3. INSPECT SLIP RING**

(Continuity)

Inspect the continuity between terminals.

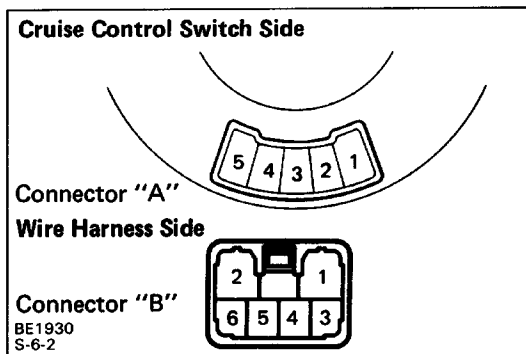

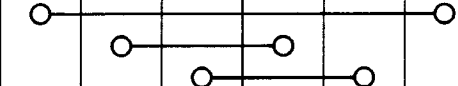
Terminal	A-2	A-3	A-4	B-4	B-5	B-6
Condition						
Constant						

If continuity is not as specified, replace the slip ring.

**4. INSPECT MAIN RELAY**

(Operation)

- (a) Connect the positive (+) lead from the battery to terminal 2 and the negative (-) lead to terminals 3 and 4.
- (b) Connect the positive (+) lead from the voltmeter to terminal 6 and the negative (-) lead to terminal 3, check that there is battery positive voltage.
- (c) Change the positive (+) lead to terminal 1, check that there is voltage less than 0.3V.

If operation is not as specified, replace the relay.

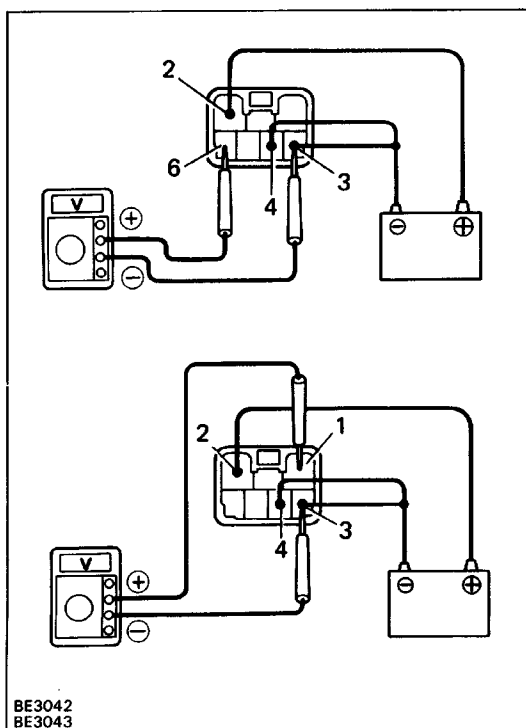

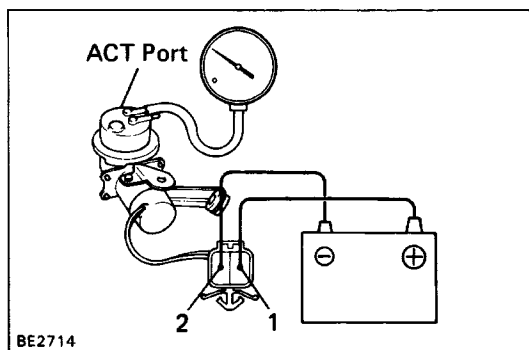

## 5. INSPECT VACUUM PUMP

(3VZ-E Engine)

- Connect a vacuum gauge to the ACT side of the pump.
- Connect the positive (+) lead from the battery to terminal 1 and the negative (-) lead to terminal 2.
- Check that there is a vacuum of 200 mmHg (7.87 in. Hg, 26.7 kPa) or above.

If operation is not as specified, replace the pump.

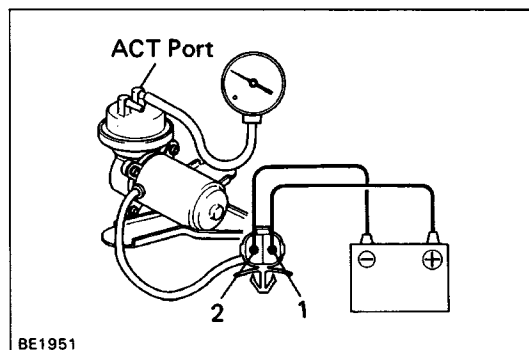

(22R-E Engine)

- Connect a vacuum gauge to the ACT side of the pump.
- Connect the positive (+) lead from the battery to terminal 1 and the negative (-) lead to terminal 2.
- Check that there is a vacuum of 200 mm Hg (7.87 in.Hg, 26.7 kPa) or above.

If operation is not as specified, replace the pump.

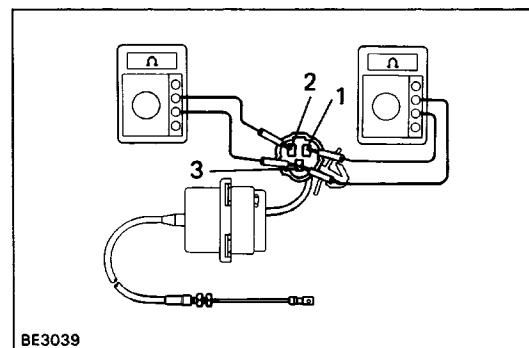

## 6. INSPECT ACTUATOR

(Resistance)

Measure the resistance value between terminals as follows.

**Resistance: 1-3 Approx. 71**

**2-3 Approx. 38**

If the resistance value is not as specified, replace the actuator.

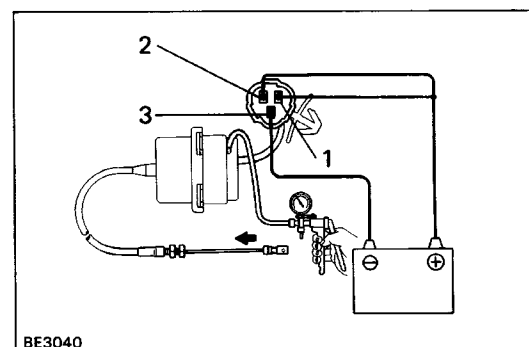

(Operation)

- Connect the positive (+) lead from the battery to terminals 1 and 2, and the negative (-) lead to terminal 3.
- Slowly apply vacuum from 0 to 300 mmHg (0 to 11.81 in.Hg, 0 to 40.0 kPa), check that the control cable can be pulled smoothly.

**Cable stroke: Approx. 36 mm (1.42 in.)**

- With the vacuum stabilized, check that the control cable does not return.

HINT: As you apply and hold the vacuum with the vacuum pump, the drawn in diaphragm will in some cases return. This does not indicate a malfunction. Actuator leakage is allowable.

- Disconnect terminal 1 or 2 and check that the control cable returns to its original position and the vacuum returns to 0 mmHg (0 in. Hg, 0 kPa).

If operation is not as specified, replace the actuator.

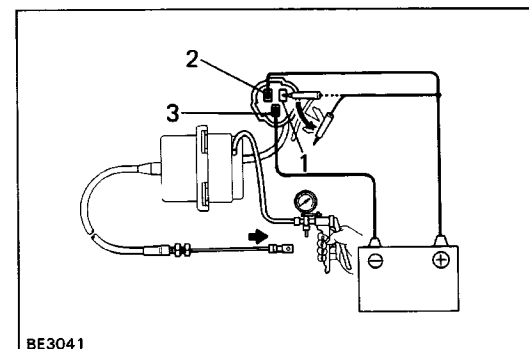

# AUDIO SYSTEM

## Parts Location

### 2-Speaker Type

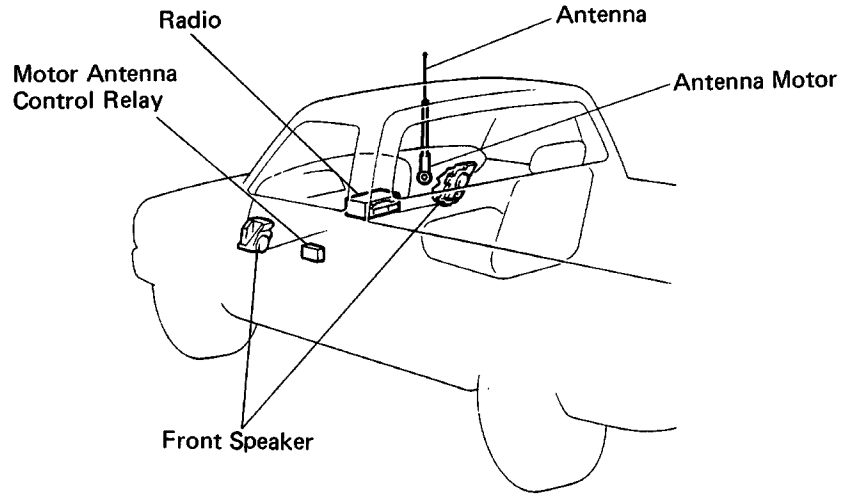

### 4-Speaker Type

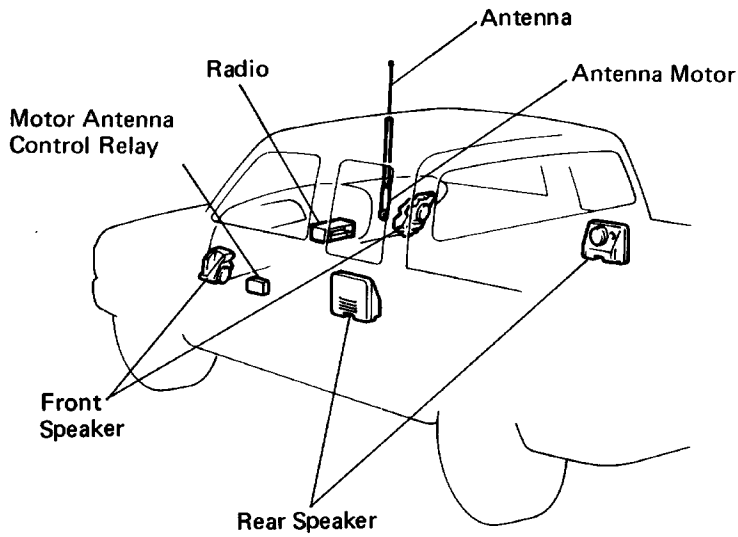

# Wiring and Connector Diagrams

Radio: Simbol R

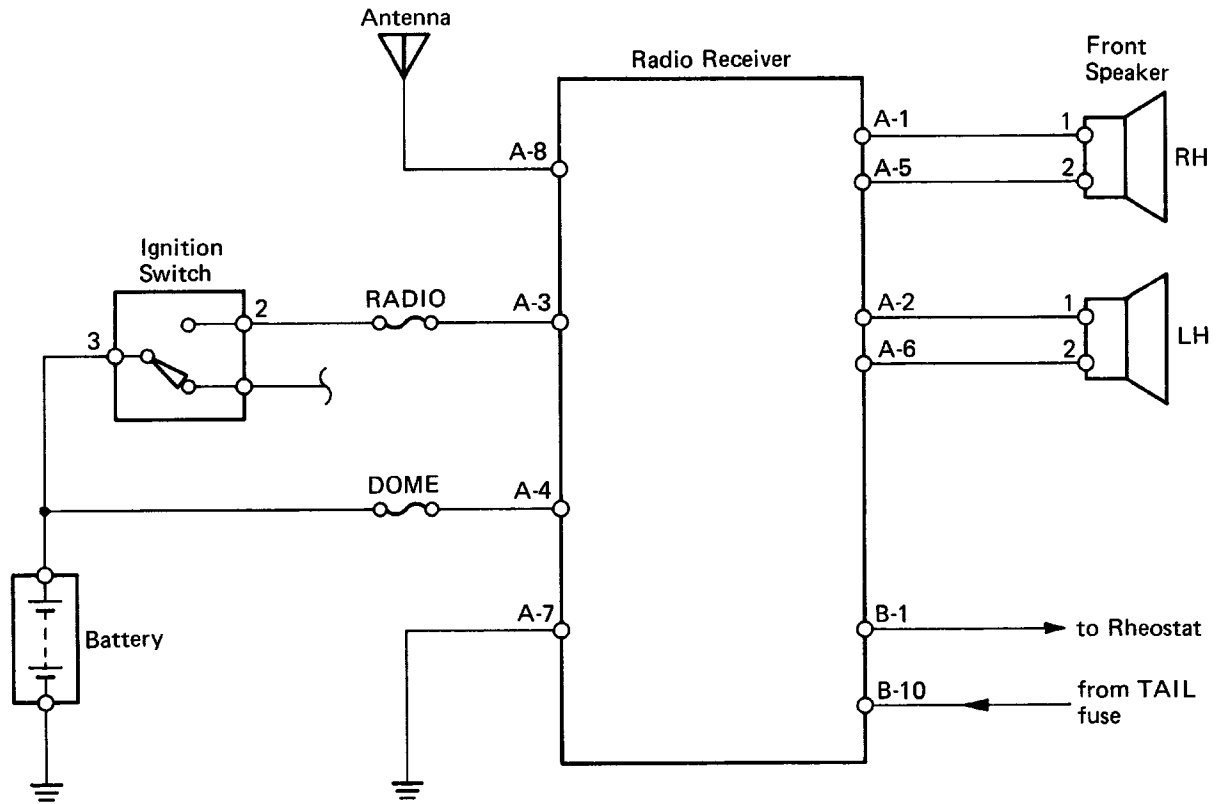

The POWER SOURCE CIRCUIT has been simplified. For full details, see page BE-8.

Radio Receiver

Connector "A"

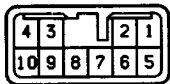

Connector "B"



Front Speaker

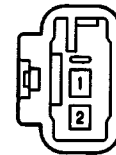

Radio-Tape Player Unit: Simbol **U**

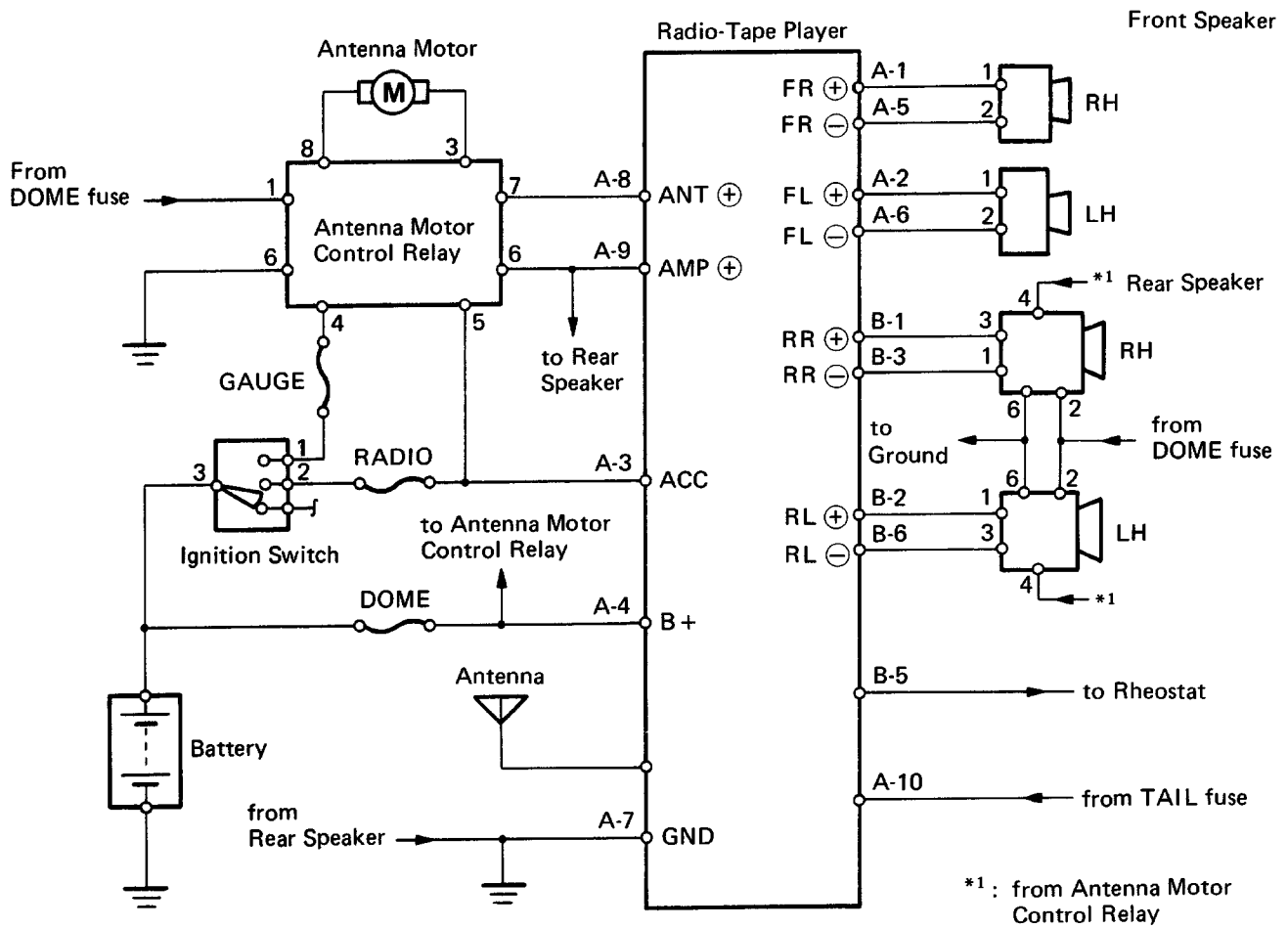

The POWER SOURCE CIRCUIT has been simplified. For full details, see page BE-8.

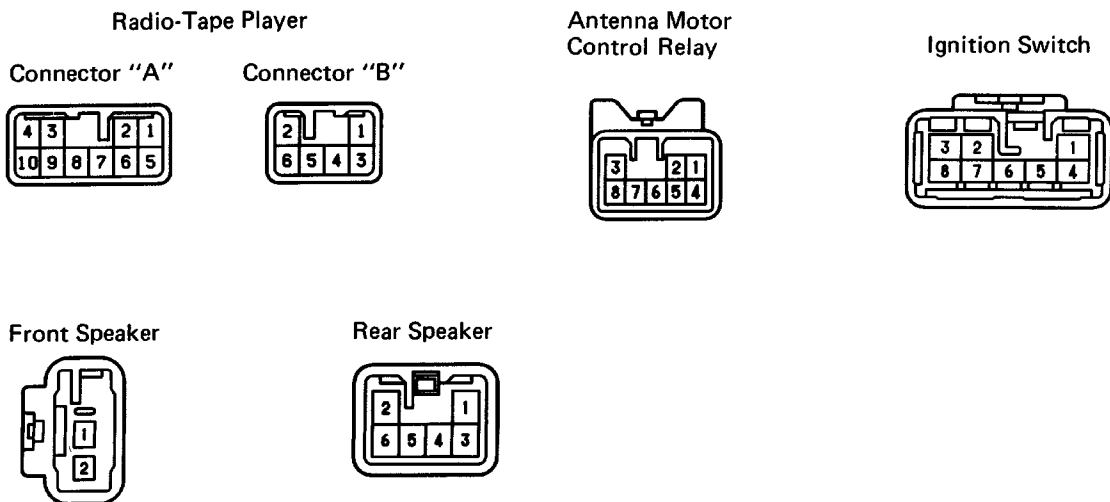

Radio-Tape Player (Separate): Symbol **S**

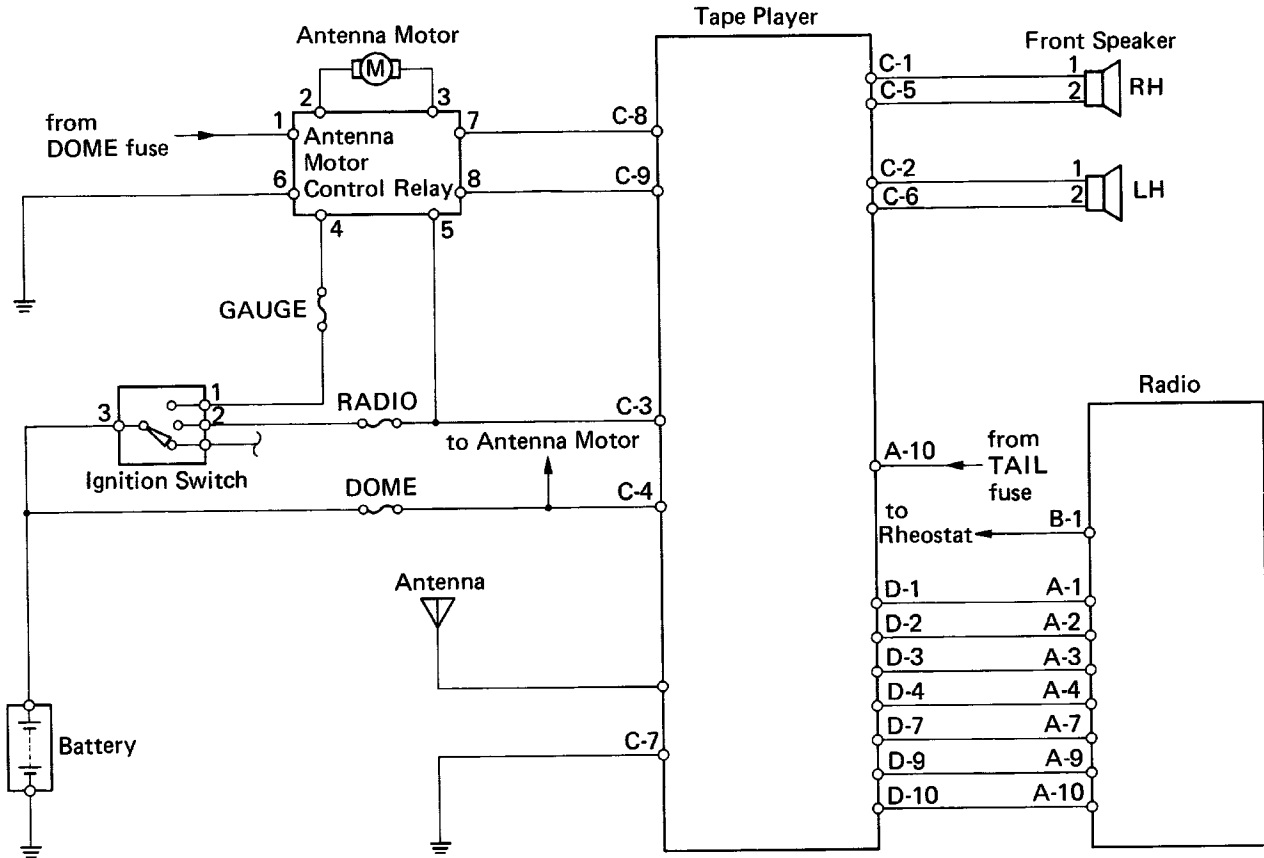

The POWER SOURCE CIRCUIT has been simplified. For full details, see page BE-8.

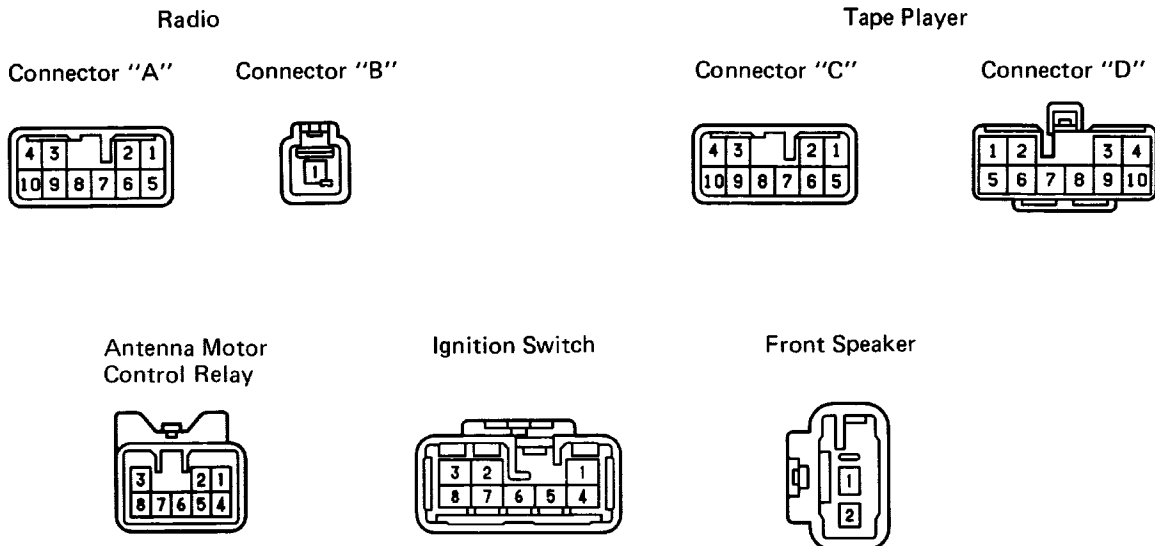

Radio-Tape Player Unit (Separate Power Amplifier): Symbol P

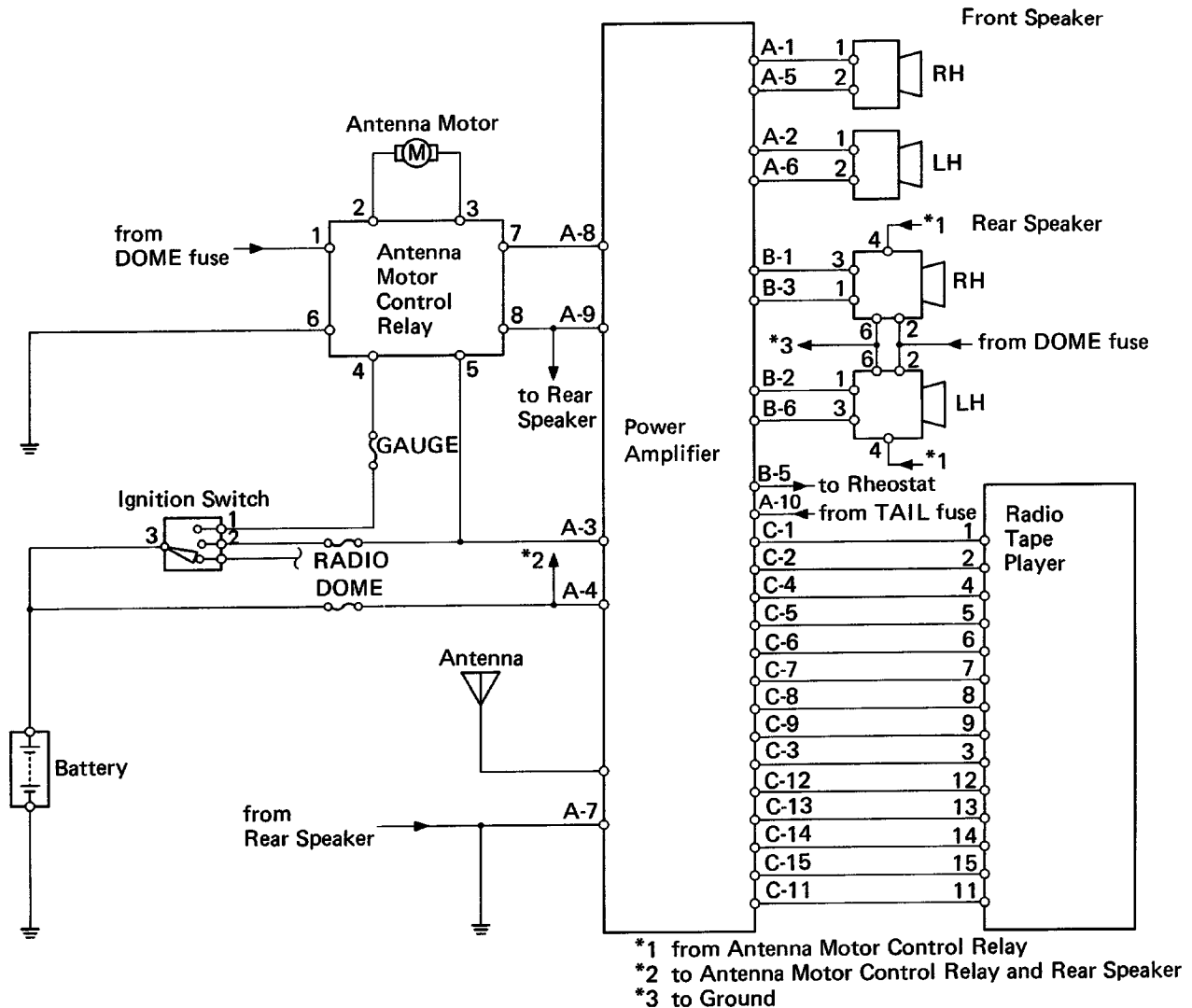

The POWER SOURCE CIRCUIT has been simplified. For full details, see page BE-8.

Power Amplifier

Radio-Tape Player

Connector "A"

Connector "B"

Connector "C"

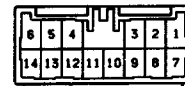
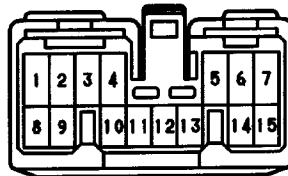
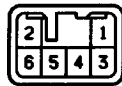
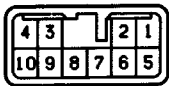

Antenna Motor Control Relay

Ignition Switch

Front Speaker

Rear Speaker

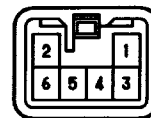
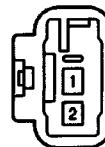
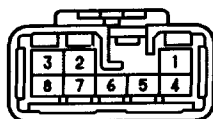



# System Description

## RADIO WAVE BAND

The radio wave bands used in radio broadcasting are as follows:

Frequency	30kHz	300kHz	3MHz	30MHz	300MHz
Designation	LF	MF	HF	VHF	
Radio wave	LM	AM (MW)	SW	FM (UKW)	
Modulation method	Amplitude modulation			Frequency modulation	

LF: Low Frequency MF: Medium Frequency HF: High Frequency VHF: Very High Frequency

HINT: In this section, the term "AM" includes LW, MW and SW, and the term "FM" includes UKW.

### SERVICE AREA

There is great difference in the size of the service area for AM, FM monaural, and FM stereo broadcasting. Thus it may happen that FM broadcast cannot be received even though AM comes in very clearly.

Not only does FM stereo have the smallest service area, but it also picks up static and other types of interference ("noise") the most easily.

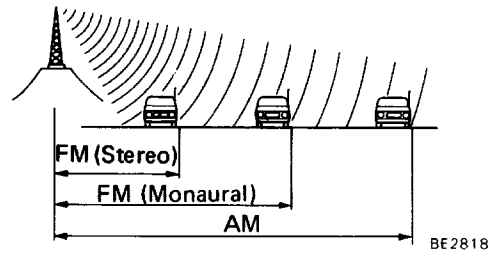

### RECEPTION PROBLEMS

Besides the problem of static, there are also the problems called "fading", "multipath", and "fade out". These problems are caused not by electrical noise but by the nature of the radio waves themselves.

#### Fading

Besides electrical interference, AM broadcasts are also susceptible to other types of interference, especially at night. This is because AM radio waves bounce off the ionosphere at night. These radio waves then interfere with the signals from the same transmitter that reach the vehicle's antenna directly. This type of interference is called "fading".

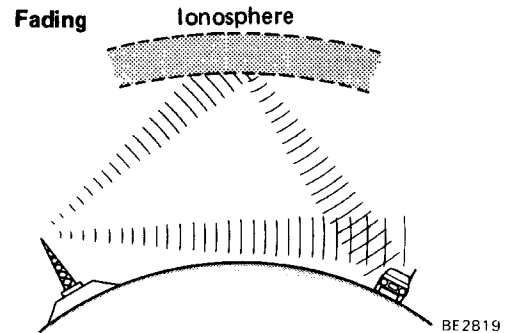

#### Multipath

One type of interference caused by the bouncing of radio waves off of obstructions is called "multipath". Multipath occurs when a signal from the broadcast transmitter antenna bounces off of buildings and mountains and interferes with the signal that is received directly.

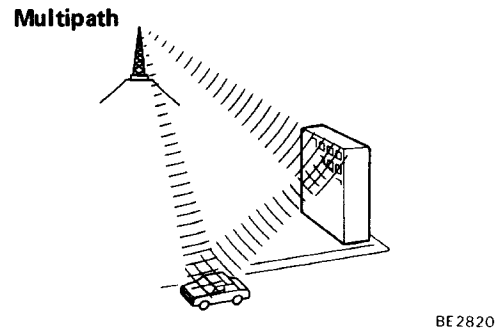

#### Fade Out

Because FM radio waves are of higher frequencies than AM radio waves, they bounce off of buildings, mountains, and other obstructions. For this reason, FM signals often seem to gradually disappear or fade away as the vehicle goes behind a building or other obstruction. This is called "fade out".

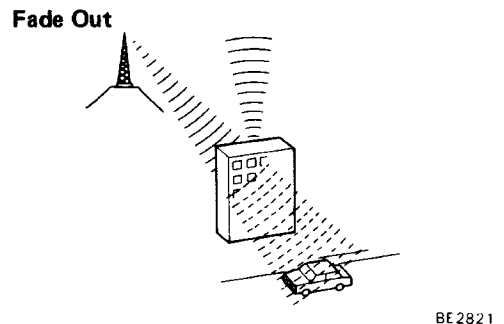

## MAINTENANCE OF TAPE PLAYER

### Head Cleaning

- (a) Raise the cassette door with your finger. Next using a pencil or like object, push in the guide.
- (b) Using a cleaning pen or cotton applicator soaked in cleaner, clean the head surface, pinch rollers and capstans.

### Example:

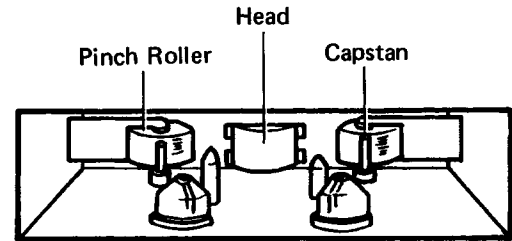

C0192

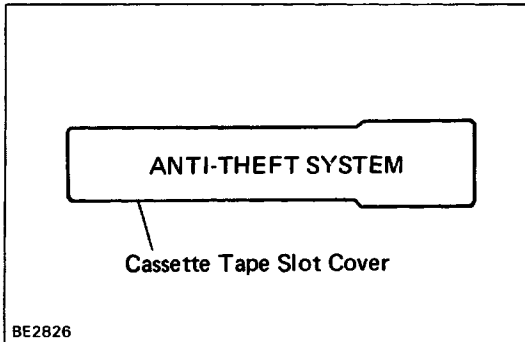

### Anti-Theft System

The anti-theft system is only provided for audio systems equipped with an Acoustic Flavor function.

HINT: The words "ANTI-THEFT SYSTEM" are displayed on the cassette tape slot cover.

For operation instructions for the anti-theft system, please consult the audio system section in the Owner's Manual (hereafter called O/M).

## 1. SETTING SYSTEM

The system is in operation once the customer has pushed the required buttons and entered the customer-selected 3-digit ID number.

(Refer to the O/M section, "SETTING THE ANTI-THEFT SYSTEM").

### HINT:

- When the audio system is shipped the ID number has not been input, so the anti-theft system is not in operation.
- If the ID number has not been input, the audio system remains the same as a normal audio system.

## 2. ANTI-THEFT SYSTEM OPERATION

If the normal electrical power source (connector or battery terminal) is cut off, the audio system becomes inoperable, even if the power supply resumes.

## 3. CANCELLING SYSTEM

The ID number chosen by the customer is input to cancel the anti-theft system.

(Refer to the O/M section, "IF THE SYSTEM IS ACTIVATED")

HINT: To change or cancel the ID number, please refer to the O/M section, "CANCELLING THE SYSTEM".

## HOW TO USE DIAGNOSTIC CHART

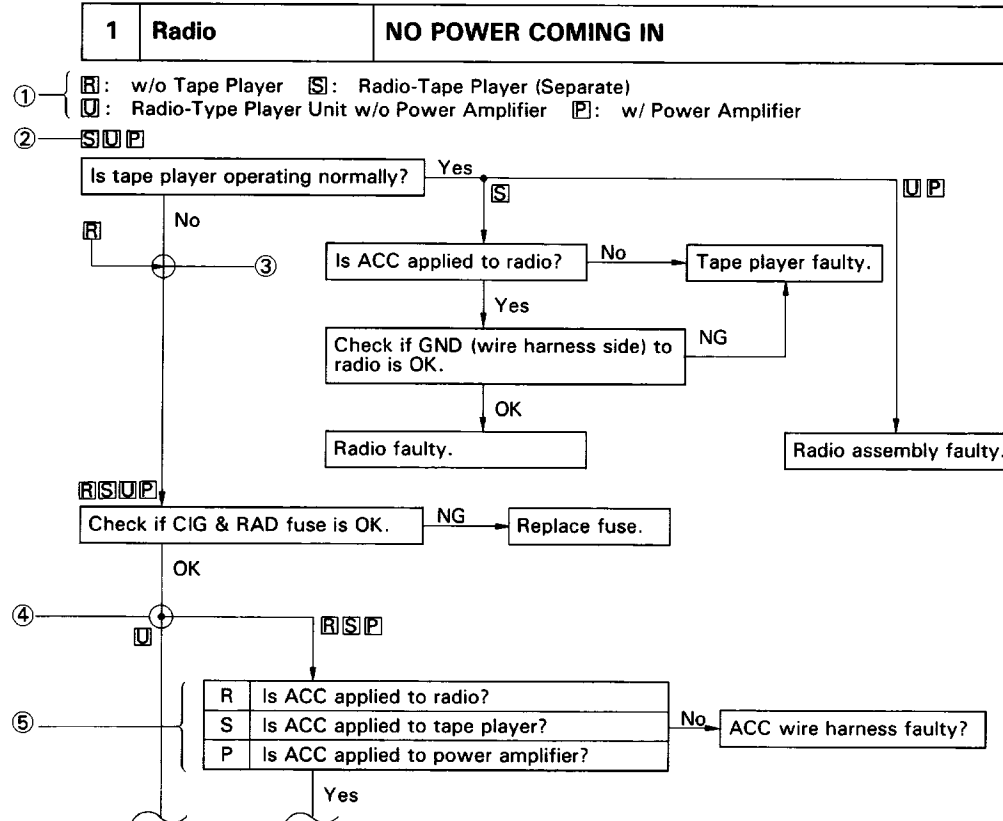

- ① Audio system type and symbol used.  
HINT: Confirm the applicable type of audio system.
- ② Symbol for type of audio system the question applies to.  
HINT: If the audio system type is not applicable, proceed to next question below.
- ③ Junction without black circle.  
HINT: Proceed to next question below.
- ④ Junction with black circle.  
HINT: Proceed to question for applicable audio system type.
- ⑤ HINT: Select question for applicable audio system type.

## Troubleshooting

**NOTICE:** when replacing the internal mechanism (computer part) of the audio system, be careful that no part of your body or clothing comes in contact with the terminals of the leads from the IC, etc. of the replacement part (spare part).

**HINT:** This inspection procedure is a simple troubleshooting which should be carried out on the vehicle during system operation and was prepared on the assumption of system component troubles (except for the wires and connectors, etc.).

Always inspect the trouble taking the following items into consideration.



- Open or short circuit of the wire harness
- Connector or terminal connection fault
- For audio systems with anti-theft system, troubleshooting items marked (\*) indicate that "Troubleshooting for ANTI-THEFT SYSTEM" should be carried out first.

	Problem	No.
Radio	No power coming in.	* 1
	Power coming in, but radio not operating.	* 2
	Noise present, but AM-FM not operating.	3
	Either speaker does not work.	4
	Either AM or FM does not work.	5
	Reception poor (Volume faint).	5
	Few preset tuning bands.	5
	Sound quality poor.	6
	Cannot set station select button.	7
	Preset memory disappears.	7
Tape Player	Cassette tape cannot be inserted.	8
	Cassette tape inserts, but no power.	* 9
	Power coming in, but tape player not operating.	10
	Either speaker does not work.	11
	Sound quality poor (Volume faint).	12
	Tape jammed, malfunction with tape speed or auto-reverse.	13
	APS, SKIP, RPT buttons not operating.	14
	Cassette tape will not eject.	* 15
Antenna	Antenna-related.	16
Noise	Noise produced by vibration or shock while driving.	17
	Noise produced when engine starts.	18

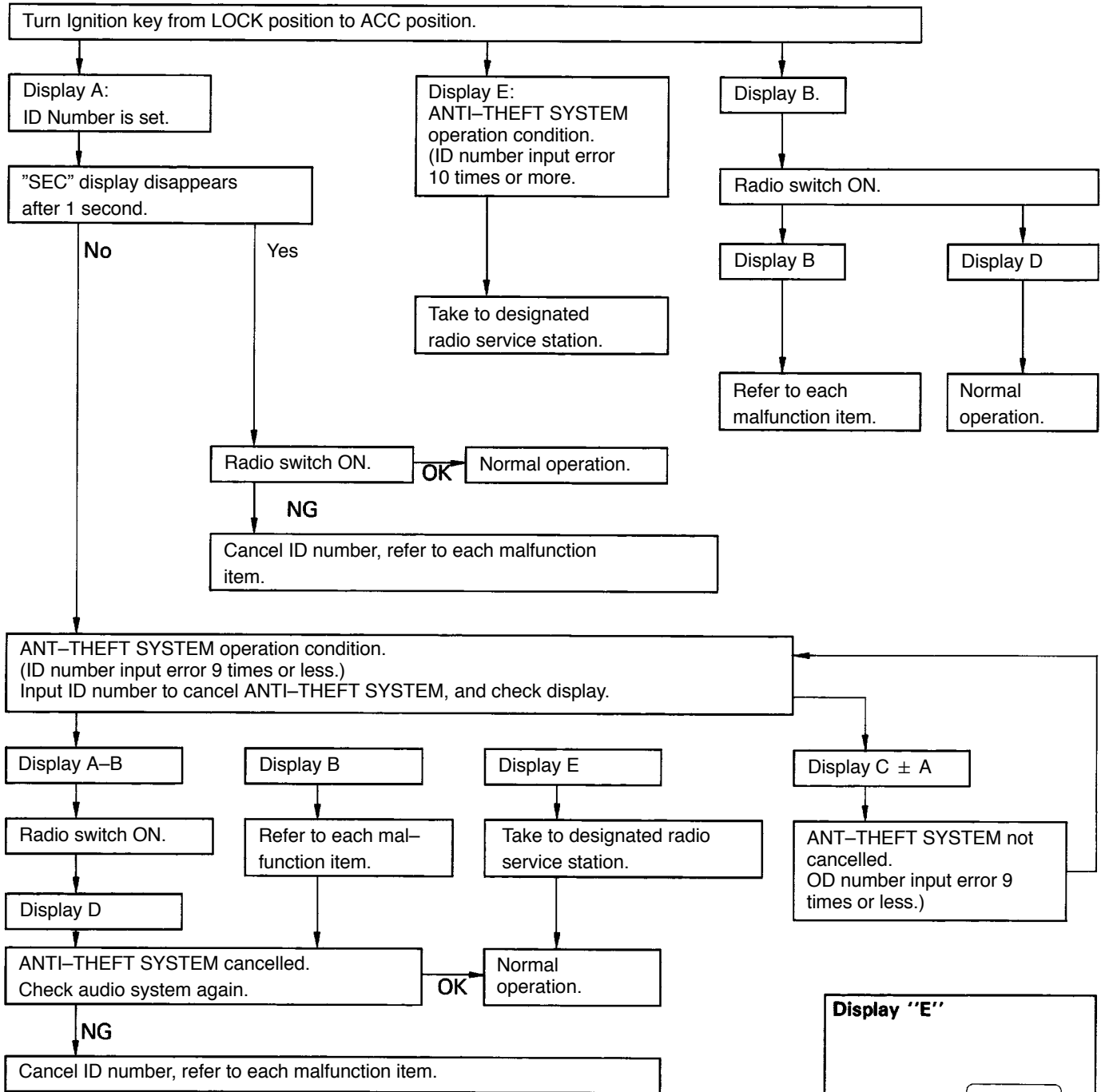
**Troubleshooting for ANTI-THEFT SYSTEM**

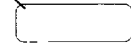
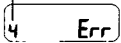

(Liquid Crystal Display (LCD) or VFD for Audio System)

<p><b>Display "A"</b></p>  <p>BE2814</p>	<p><b>Display "B"</b></p> <p>Blank, No Illumination</p>  <p>BE2815</p>	<p><b>Display "C"</b></p> <p>Error Times</p>  <p>BE2816</p>	<p><b>Display "D" Example:</b></p> <p>Radio Display</p>  <p>BE2817</p>
---	---	---	---

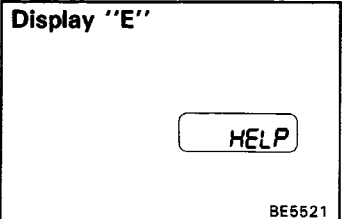

**HINT:**

- Refer to Owner's Manual for operation details of ANTI-THEFT SYSTEM.
- When the ID number has been cancelled, reset the same number after completing the operation, or inform the customer that it has been cancelled.

<b>1</b>	<b>Radio</b>	<b>NO POWER COMING IN</b>
----------	--------------	---------------------------

[R] Radio [S]: Radio + Tape Player [U]: Radio-Tape Player (Built-in Power Amplifier)

[P] Radio-Tape Player (Separate Power Amplifier)

[S][U][P]

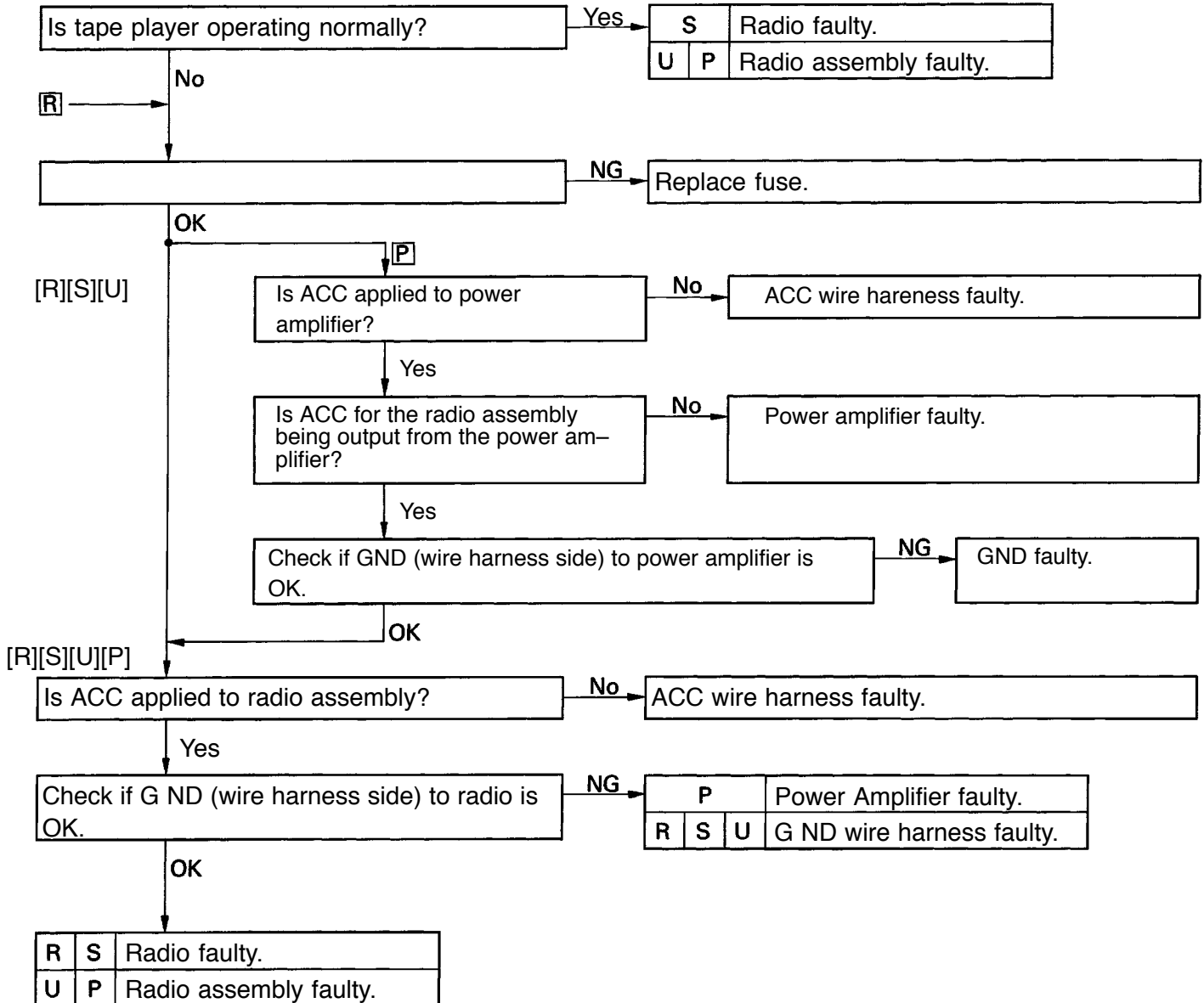

<b>2</b>	<b>Radio</b>	<b>POWER COMING IN, BUT RADIO NOT OPERATING</b>
----------	--------------	---

[R] Radio [S] Radio + Tape Player [U] Radio-Tape Player (Built-in Power Amplifier)

[P] Radio-Tape Player (Separate Power Amplifier)

[S][U][P]

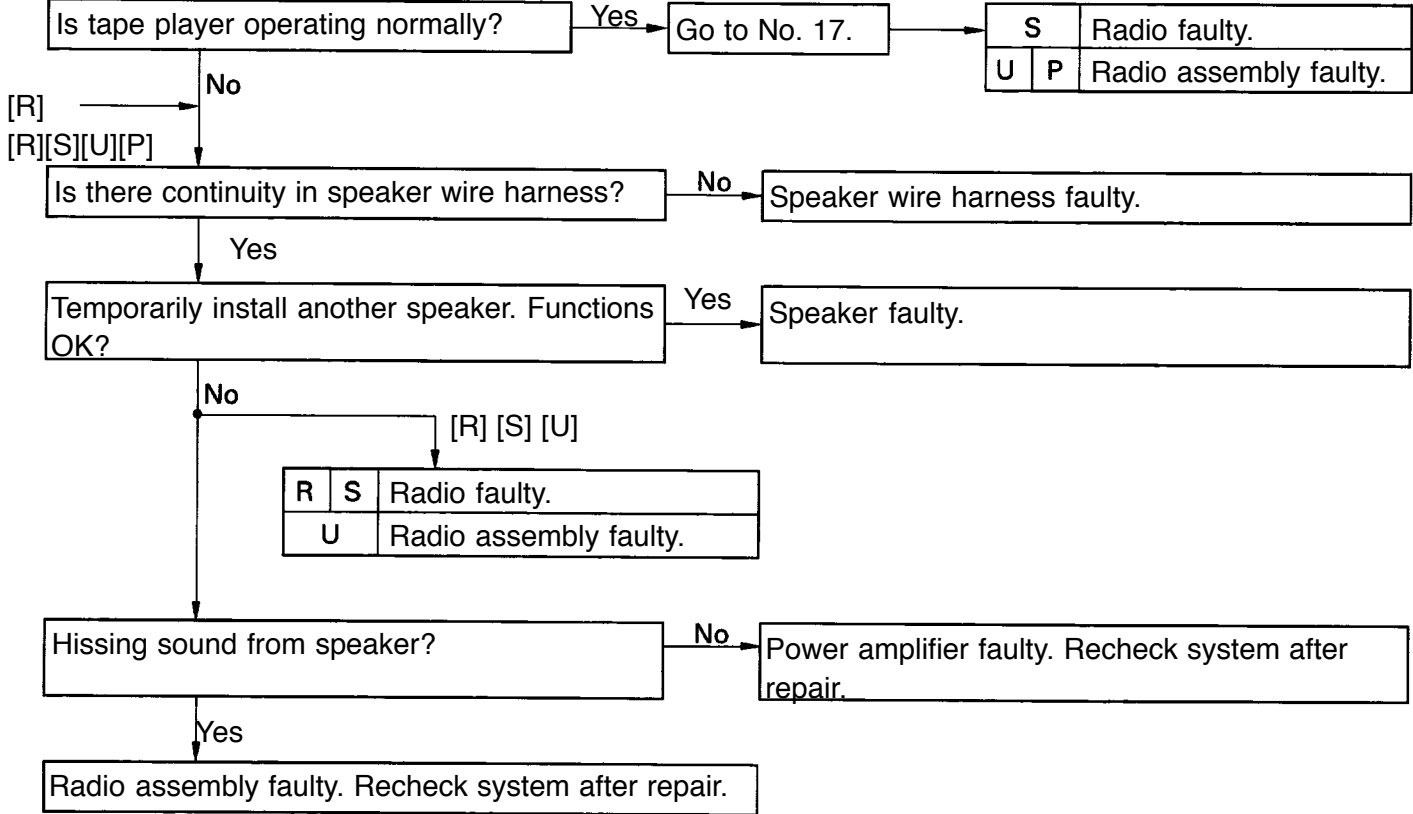

<b>3</b>	<b>Radio</b>	<b>NOISE PRESENT, BUT AM-FM NOT OPERATING</b>
----------	--------------	---

[R] Radio [S]: Radio + Tape Player [U]: Radio-Tape Player (Built-in Power Amplifier)

[P] Radio-Type Player (Separate Power Amplifier)

[S] [U] [P]

If radio side faulty

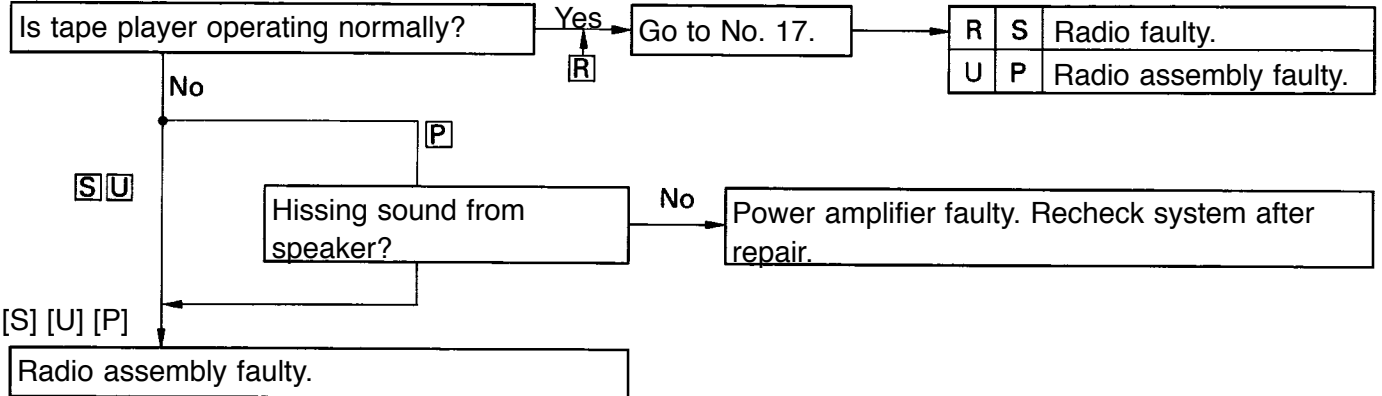

<b>4</b>	<b>Radio</b>	<b>EITHER SPEAKER DOES NOT WORK</b>
----------	--------------	-------------------------------------

[R] Radio [S] Radio + Tape Player [U] Radio-Tape Player (Built-in Power Amplifier)

[P] Radio-Tape Player (Separate Power Amplifier)

[S][U][P]

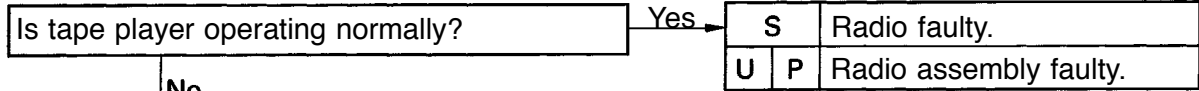

[R] ———→  
[R][S][U][P]

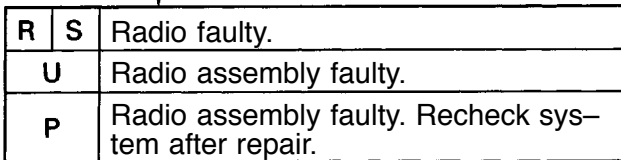
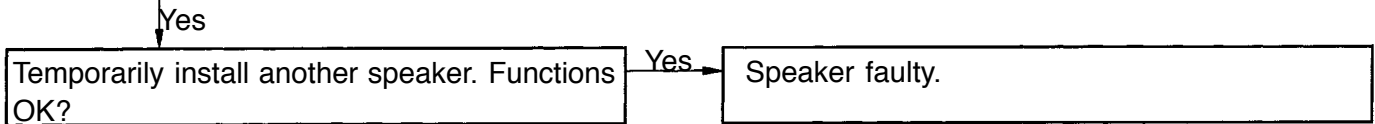
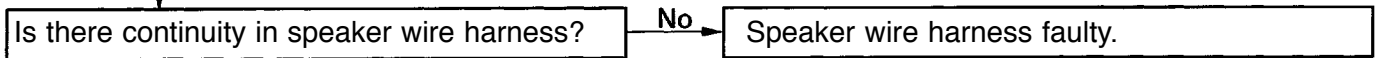
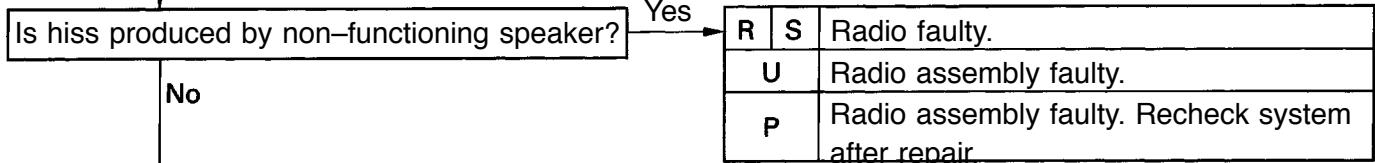



<b>5</b>	<b>Radio</b>	<b>EITHER AM OR FM DOES NOT WORK, RECEPTION POOR (VOLUME FAINT), FEW PRESET TUNING BANDS</b>
----------	--------------	--

[R] Radio [S] Radio + Tape Player [U] Radio-Tape Player (Built-in Power Amplifier)

[P] Radio-Tape Player (Separate Power Amplifier)

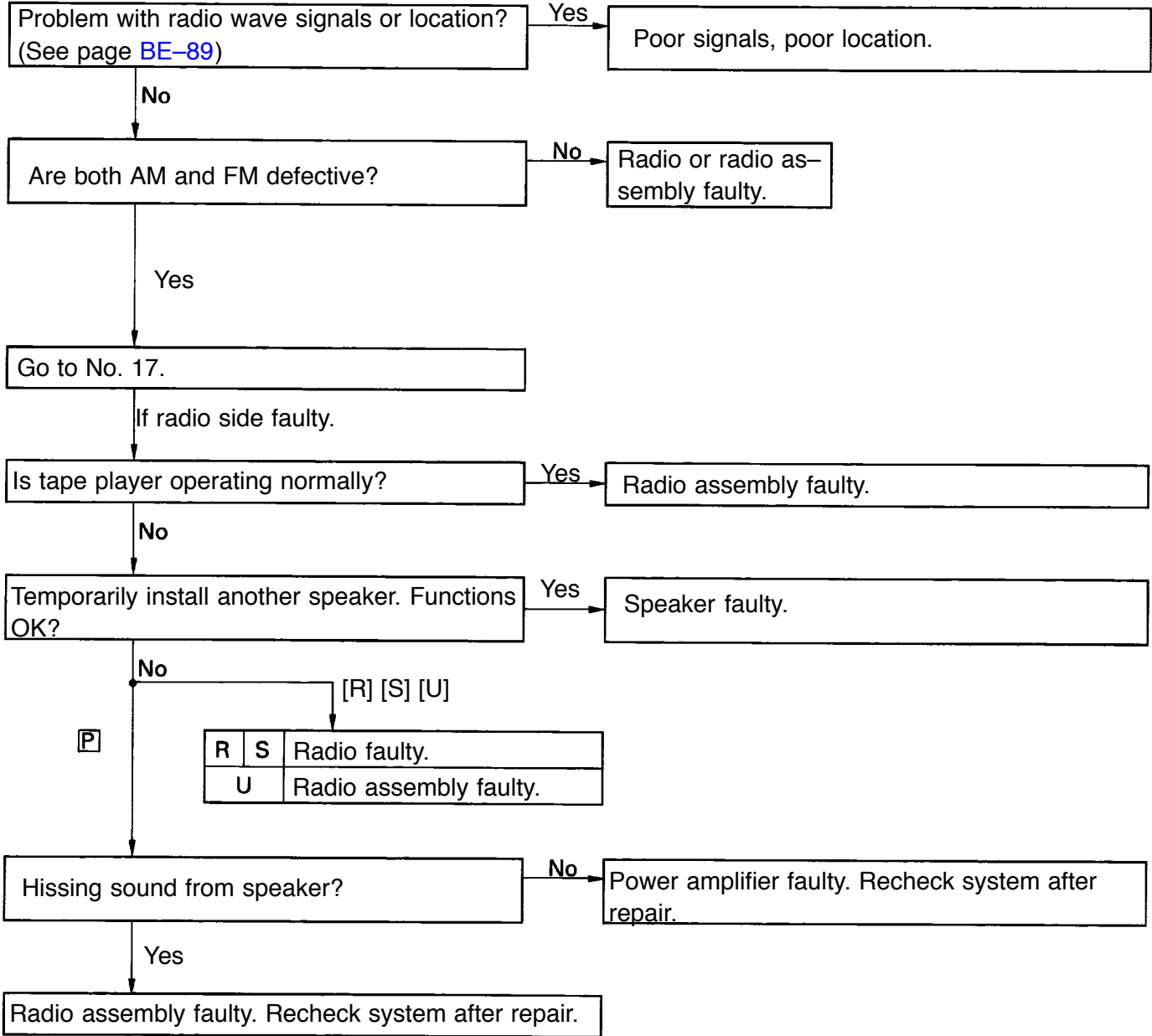

<b>6</b>	<b>Radio</b>	<b>SOUND QUALITY POOR</b>
----------	--------------	---------------------------

[E] Radio [S] Radio + Tape Player [U] Radio-Tape Player (Built-in Power Amplifier)

[P] Radio-Tape Player (Separate Power Amplifier)

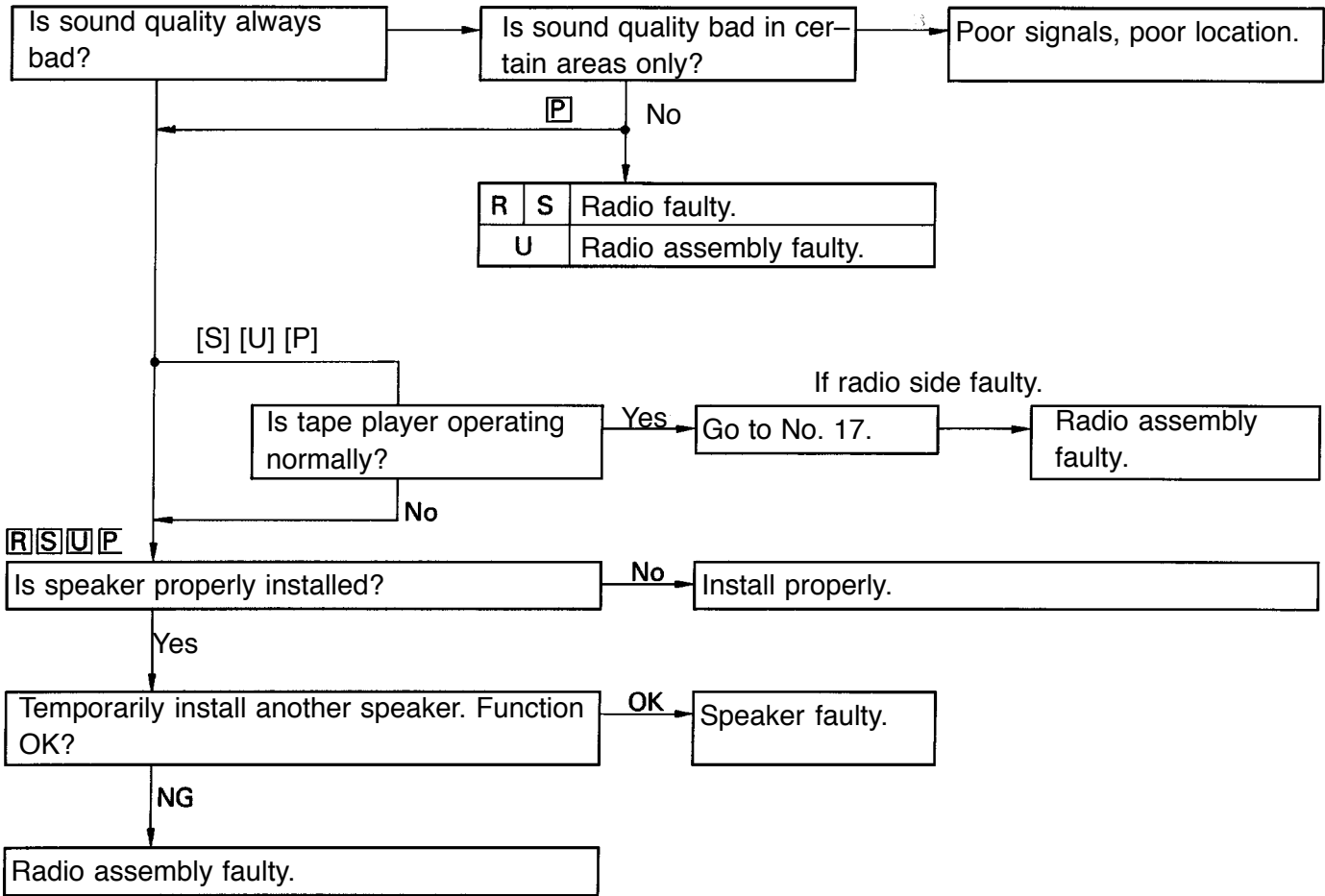

<b>7</b>	<b>Radio</b>	<b>CANNOT SET STATION SELECT BUTTON, PRESET MEMORY DISAPPEARS</b>
----------	--------------	---

[R] Radio [S] Radio + Tape Player [U] Radio-Tape Player (Built-in Power Amplifier)

[P] Radio-Tape Player (Separate Power Amplifier)

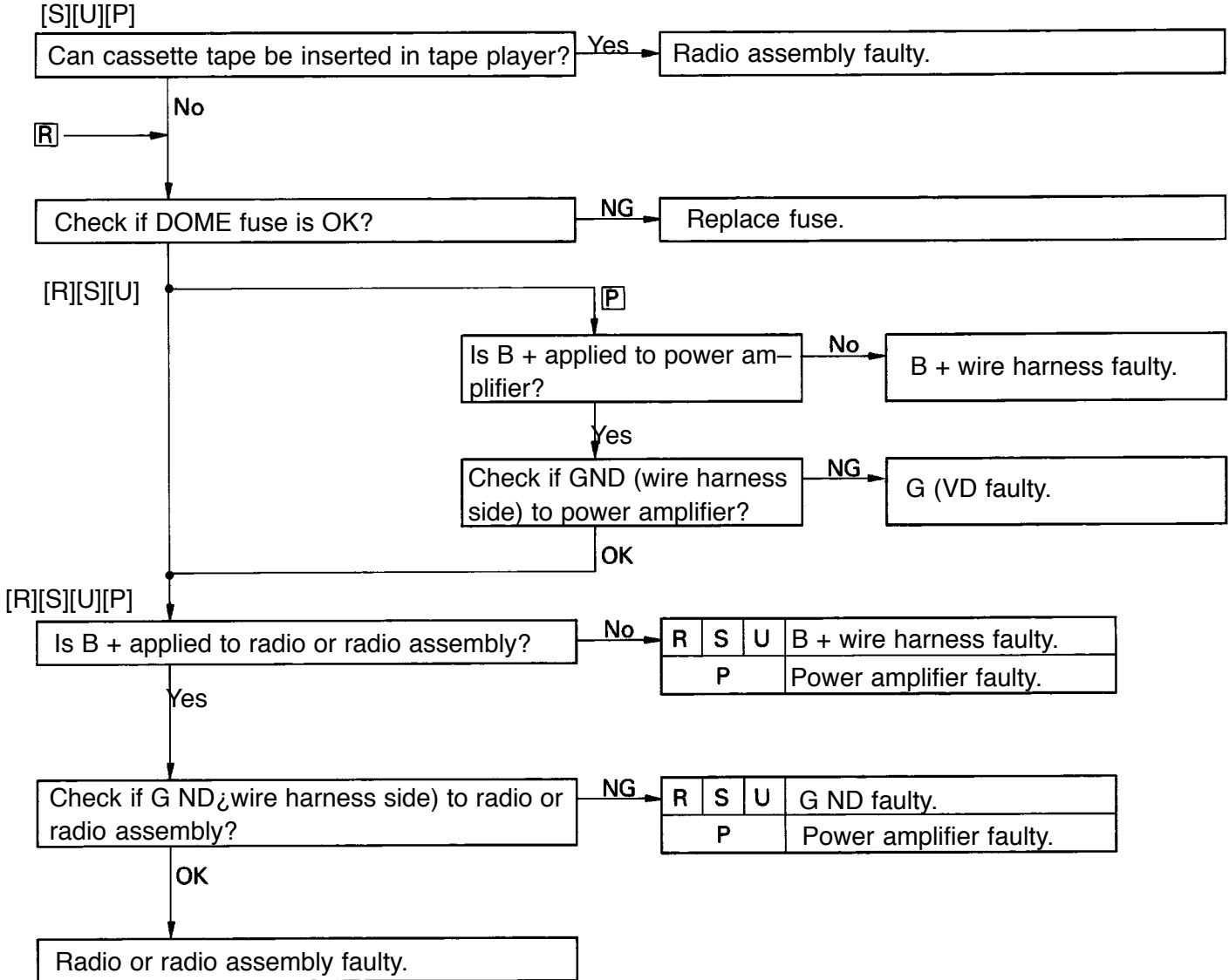

<b>8</b>	<b>Tape Player</b>	<b>CASSETTE TAPE CANNOT BE INSERTED</b>
----------	--------------------	---

[S] Radio + Tape Player [U] Radio-Tape Player (Built-in Power Amplifier)

[P] Radio-Tape Player (Separate Power Amplifier)

[S][U][P]

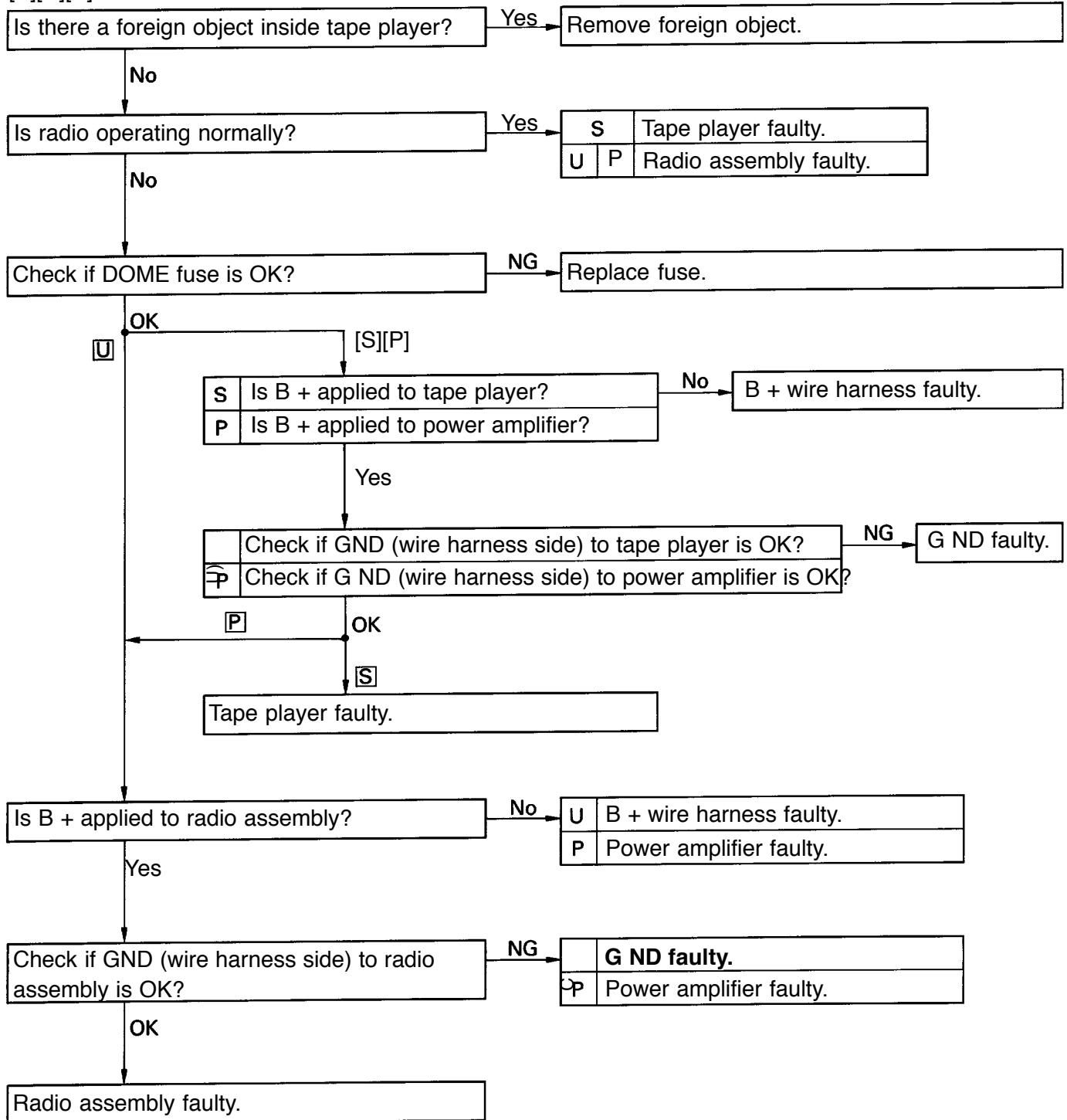

<b>9</b>	<b>Tape Player</b>	<b>CASSETTE TAPE INSERTS, BUT NO POWER</b>
----------	--------------------	--

[S] Radio + Tape Player [U] Radio-Tape Player (Built-in Power Amplifier)

[P] Radio-Tape Player (Separate Power Amplifier)

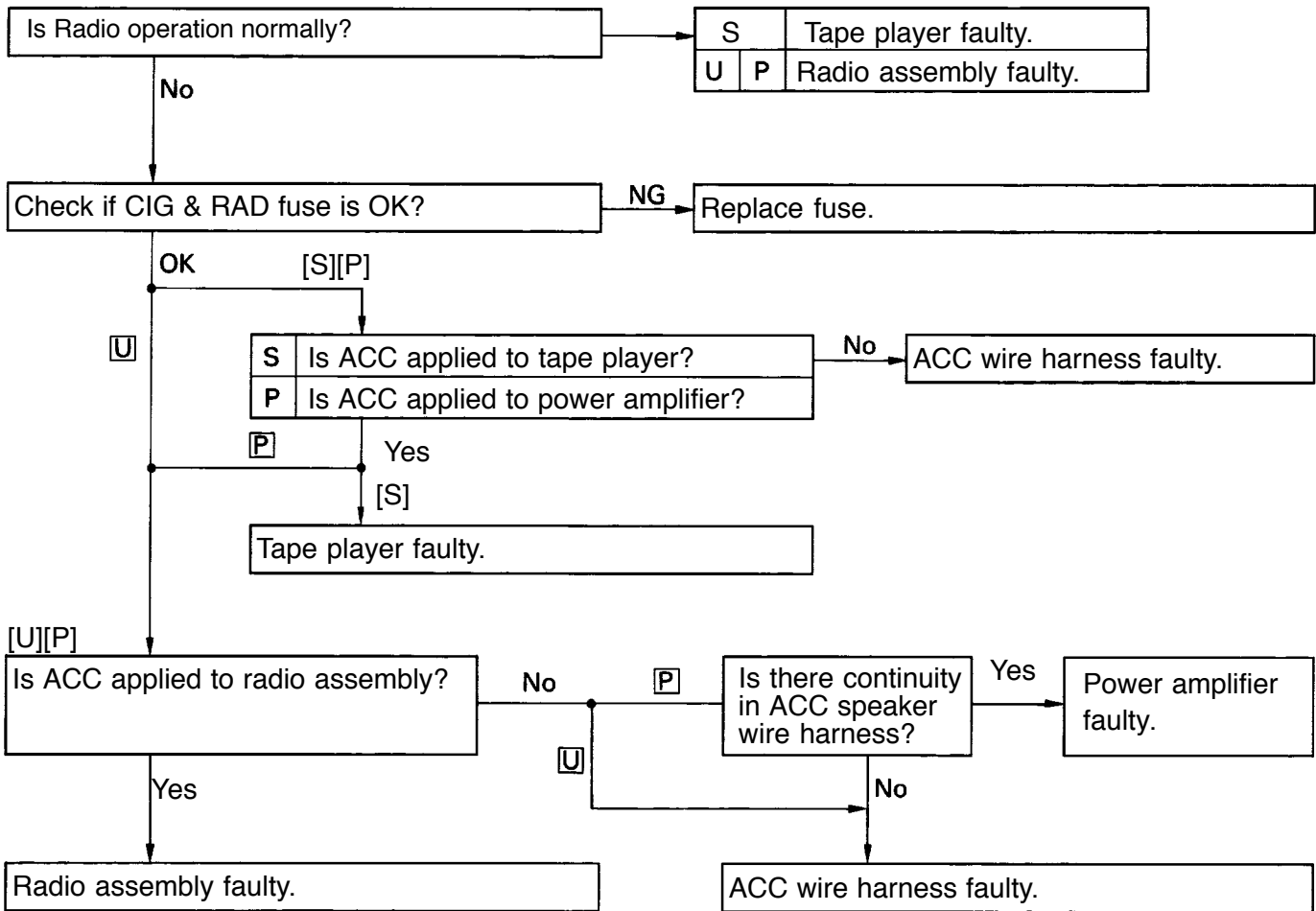

<b>10</b>	<b>Tape Player</b>	<b>POWER COMING IN, BUT TAPE PLAYER NOT OPERATING</b>
-----------	--------------------	---

[S] Radio + Tape Player [U] Radio-Tape Player (Built-in Power Amplifier)

[P] Radio-Tape Player (Separate Power Amplifier)

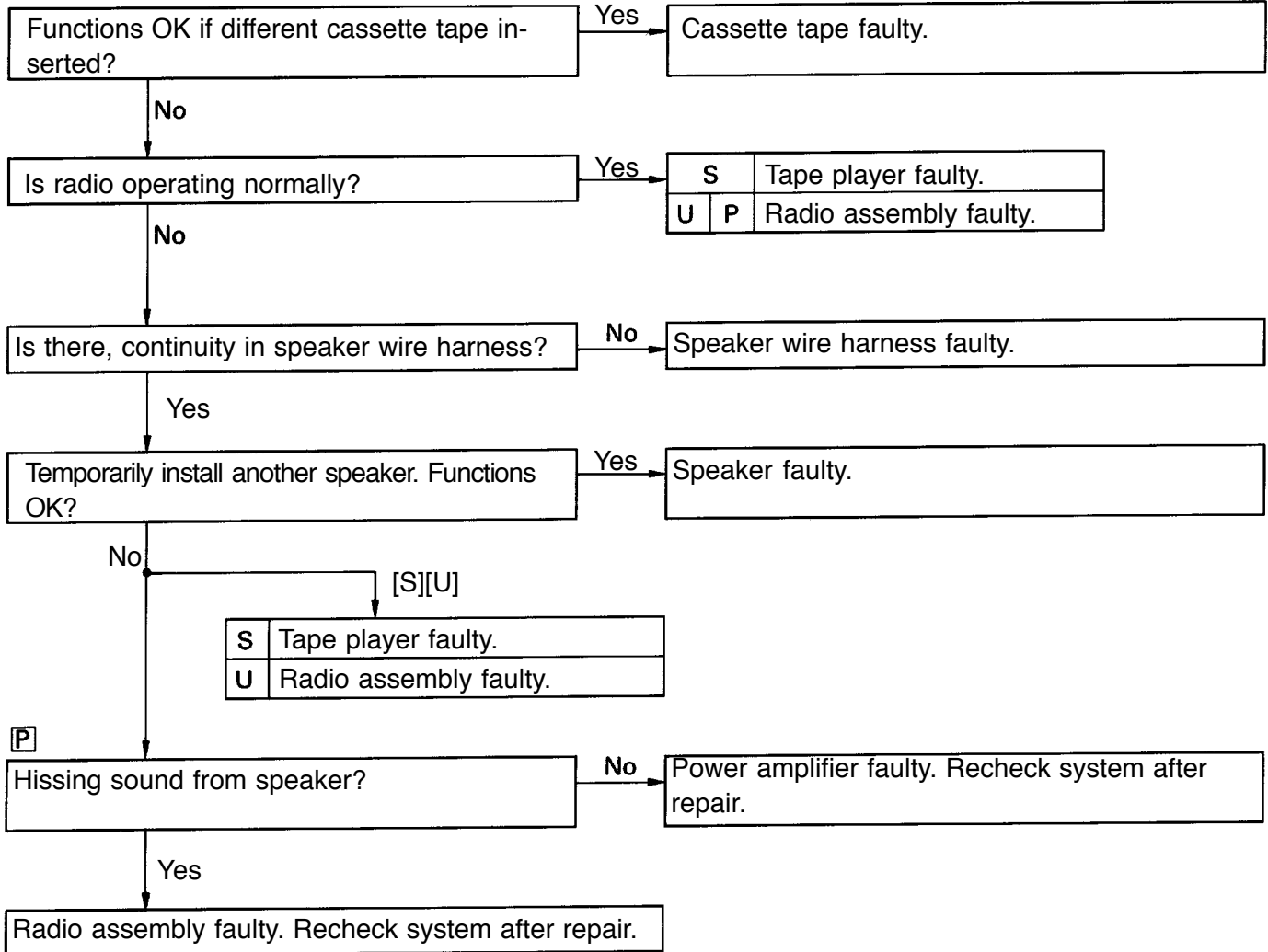

<b>11</b>	<b>Tape Player</b>	<b>EITHER SPEAKER DOES NOT WORK</b>
-----------	--------------------	-------------------------------------

[S] Radio + Tape Player [U] Radio-Tape Player (Built-in Power Amplifier)

[P] Radio-Tape Player (Separate Power Amplifier)

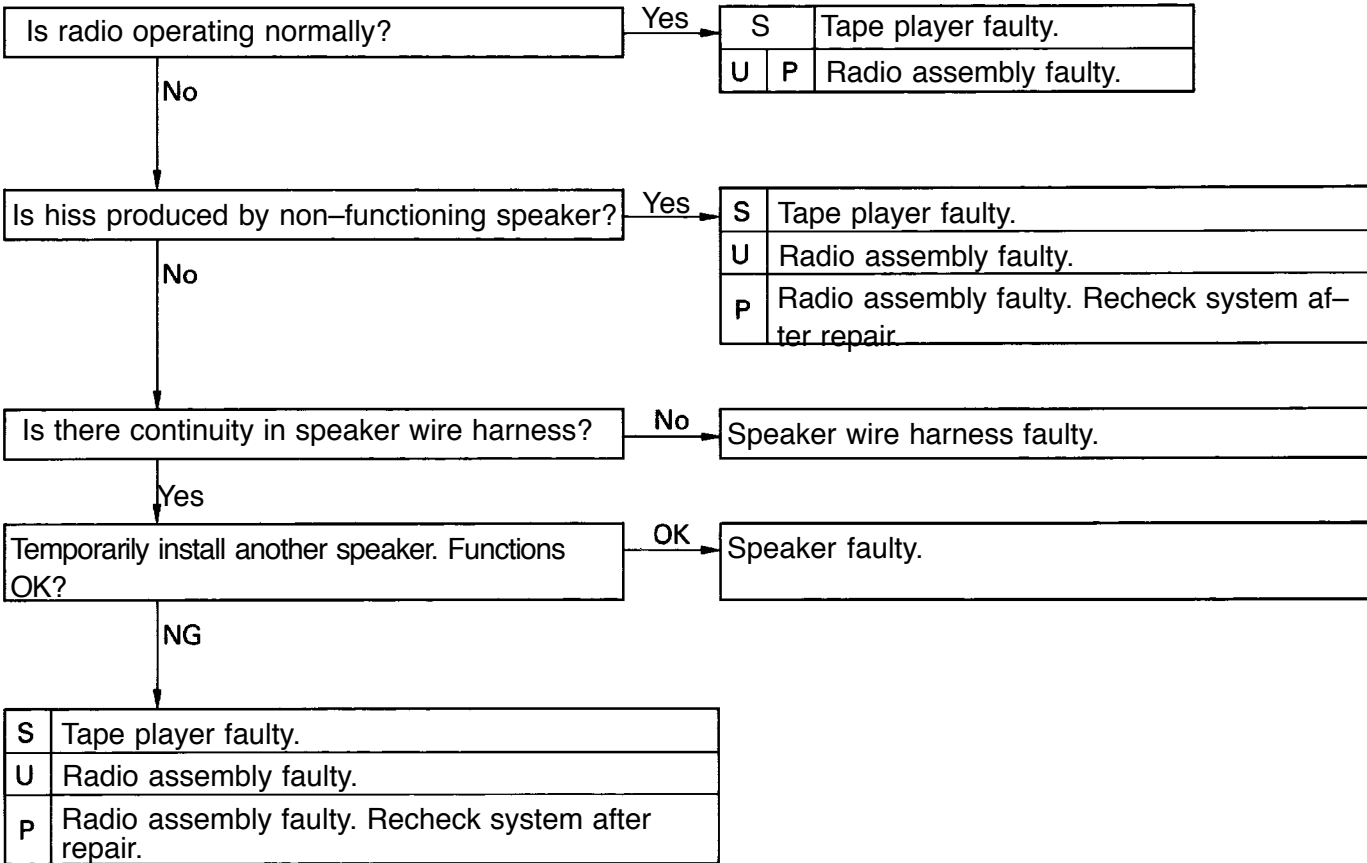

<b>12</b>	Tape Player	<b>SOUND QUALITY POOR (VOLUME FAINT)</b>
-----------	-------------	--

[S] Radio + Tape Player [U] Radio-Tape Player (Built-in Power Amplifier)

[P] Radio-Tape Player (Separate Power Amplifier)

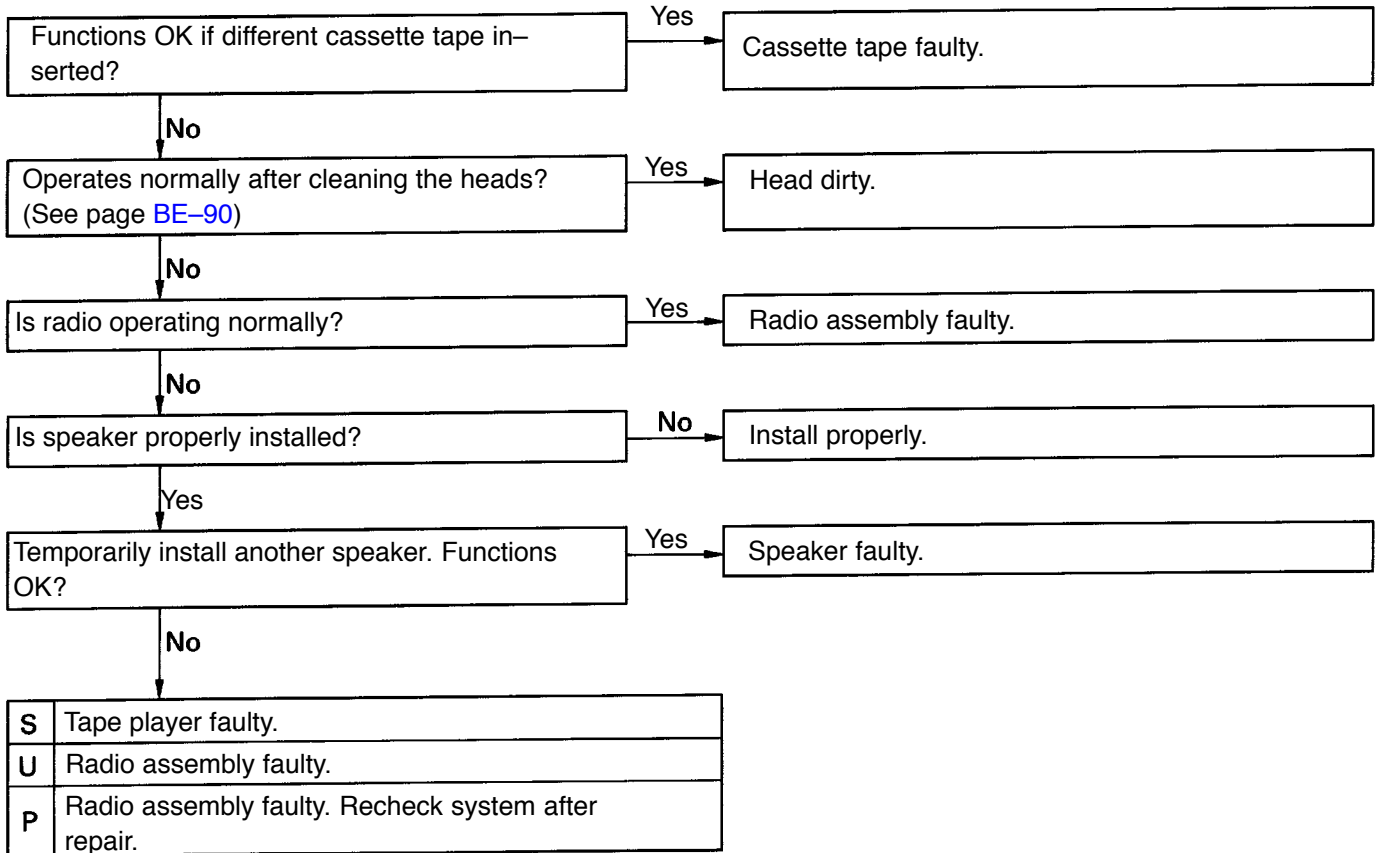

<b>13</b>	Tape Player	<b>TAPE JAMMED, MALFUNCTION WITH TAPE SPEED OR AUTO-REVERSE</b>
-----------	-------------	---

[S] Radio + Tape Player [U] Radio-Tape Player (Built-in Power Amplifier)

[P] Radio-Tape Player (Separate Power Amplifier)

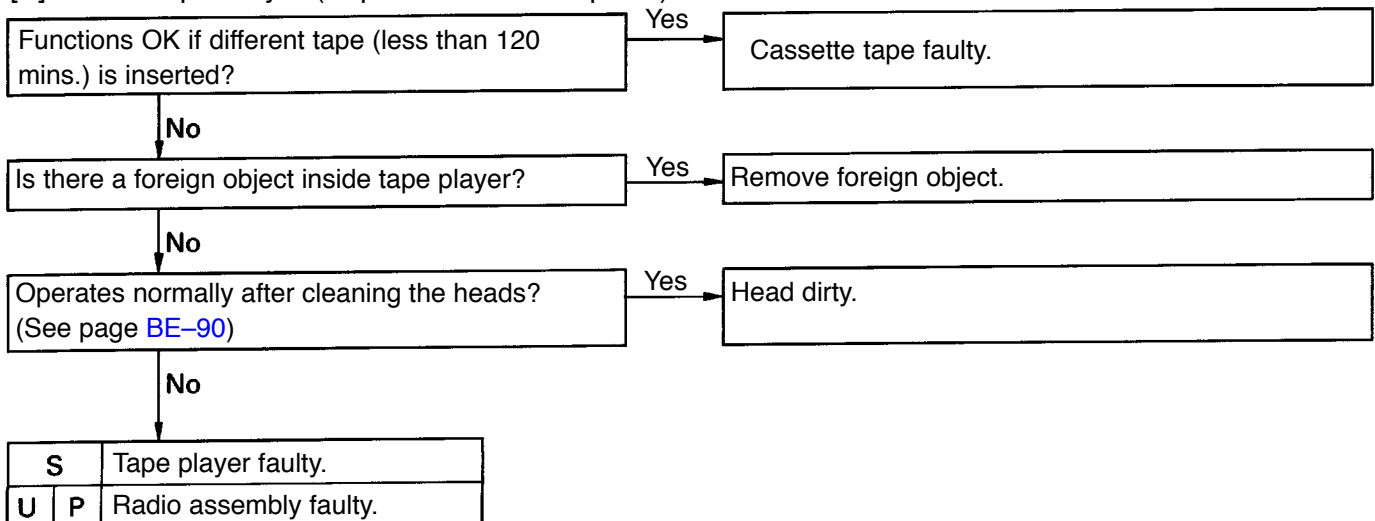



<b>14</b>	Tape Player	<b>APS, SKIP, RPT BUTTONS NOT OPERATING</b>
-----------	-------------	---

[S] Radio + Tape Player [U] Radio-Tape Player (Built-in Power Amplifier)

[P] Radio-Tape Player (Separate Power Amplifier)

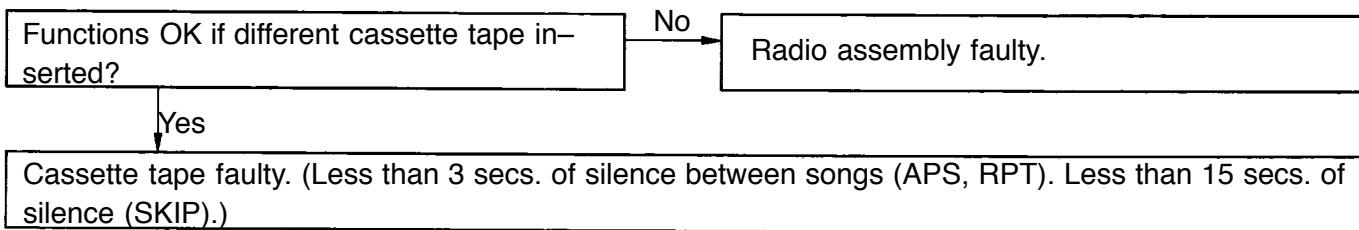

<b>15</b>	Tape Player	<b>CASSETTE TAPE WILL NOT EJECT</b>
-----------	-------------	-------------------------------------

[S] Radio + Tape Player [U] Radio-Tape Player (Built-in Power Amplifier)

[P] Radio-Tape Player (Separate Power Amplifier)

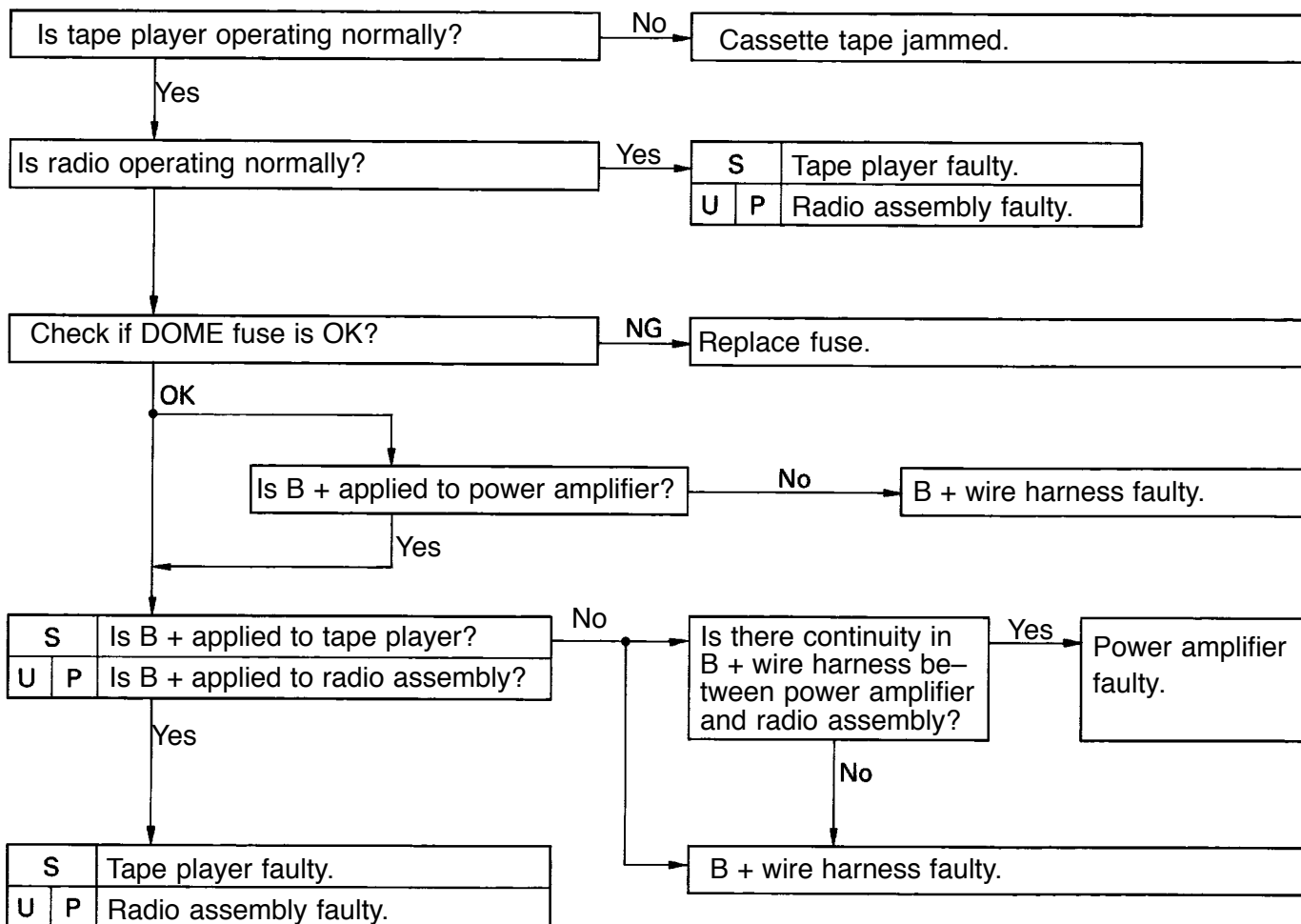

<b>16</b>	<b>Antenna</b>	<b>ANTENNA-RELATED</b>
-----------	----------------	------------------------

24-a: Pole Antenna

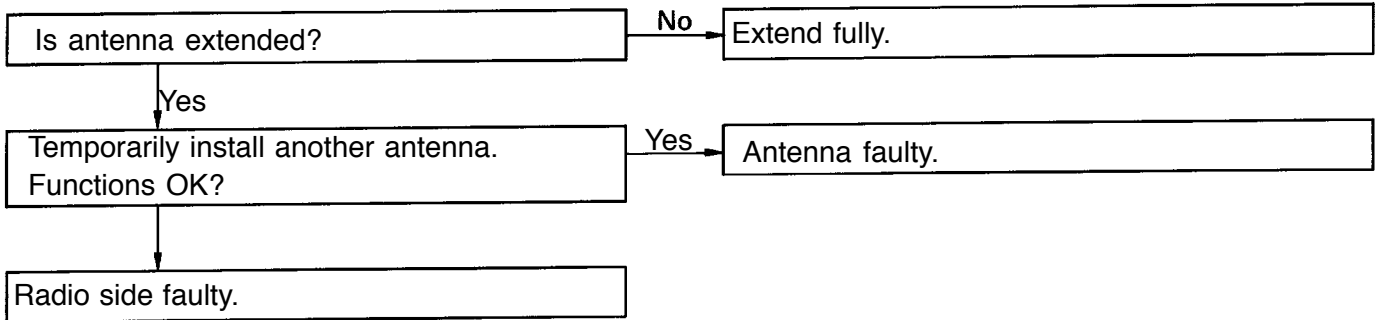

24-b: Motor Antenna

[M] : Motor Antenna (Radio Linked Type) 0 : Motor Antenna (Except Radio-Linked Type)

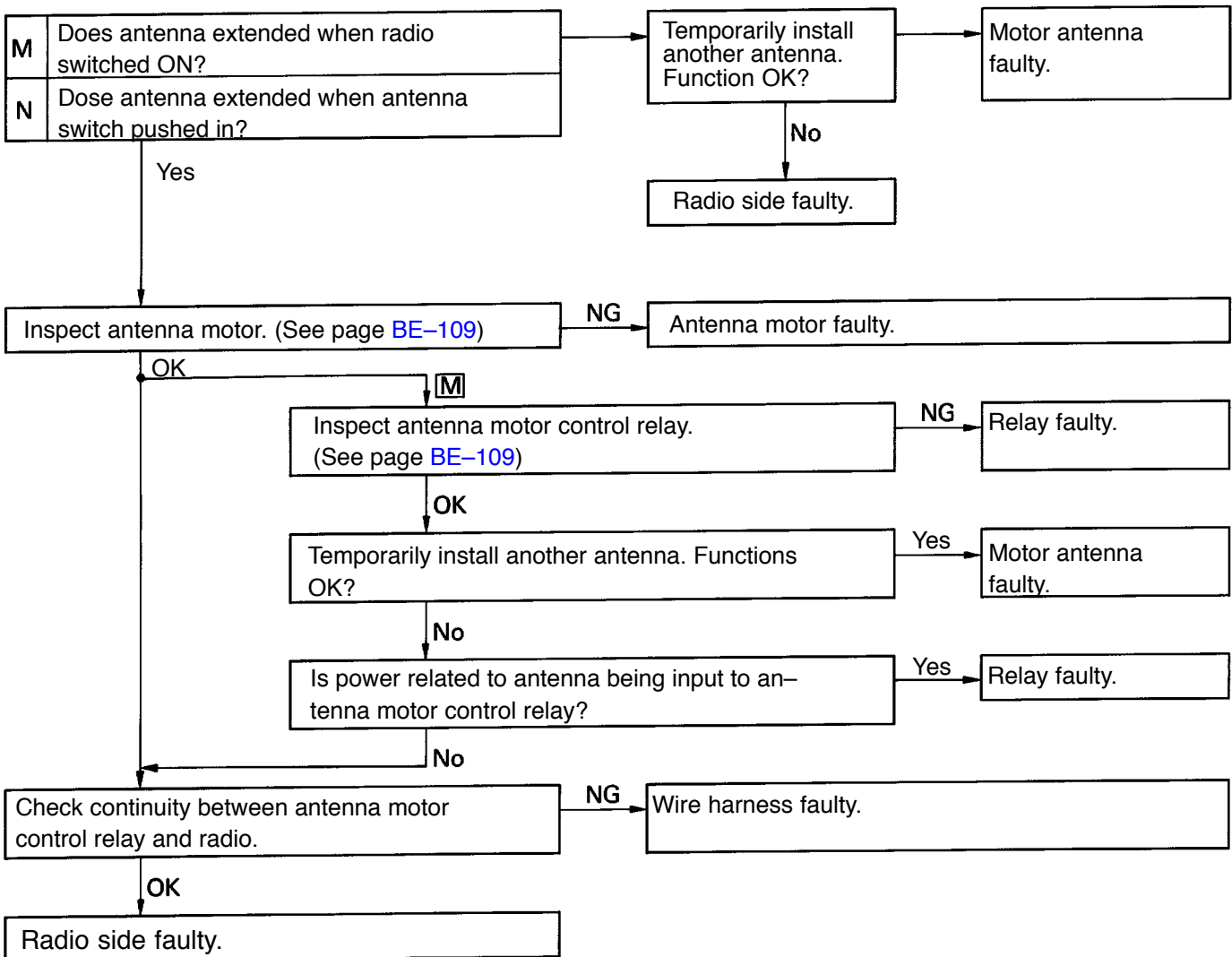

<b>17</b>	<b>Noise</b>	<b>NOISE PRODUCED BY VIBRATION OR SHOCK WHILE DRIVING</b>
-----------	--------------	---

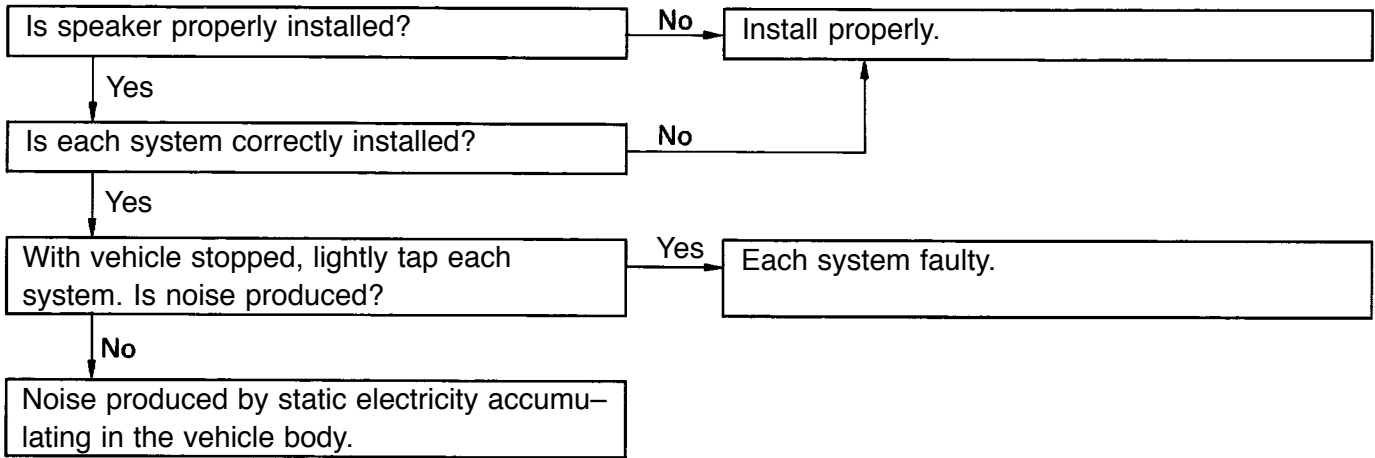

<b>18</b>	Noise	<b>NOISE PRODUCED WHEN ENGINE STARTS</b>
-----------	-------	--

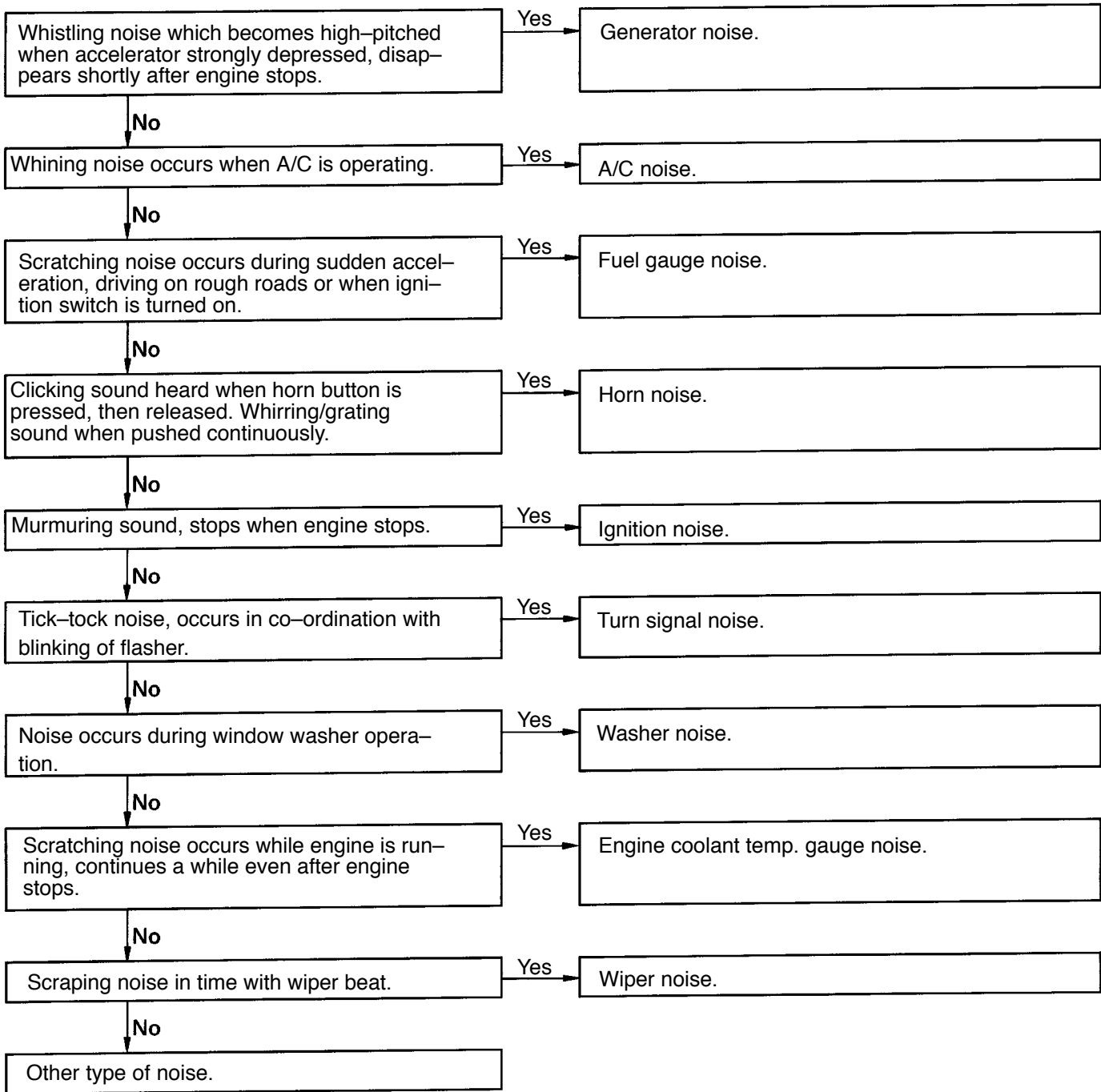

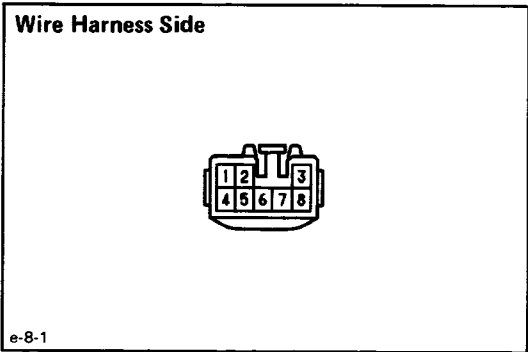
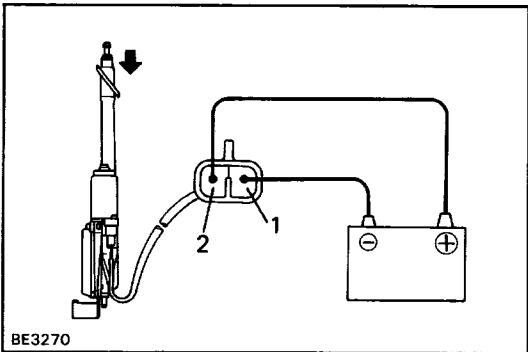
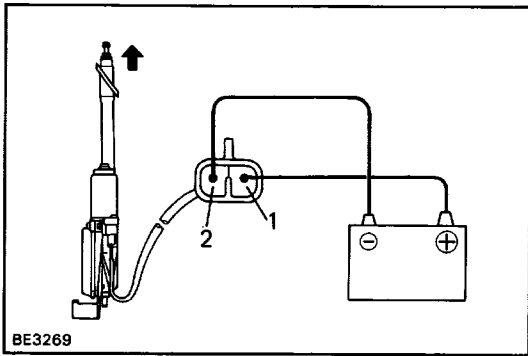

## Parts Inspection

### 1. INSPECT ANTENNA MOTOR

- (a) Connect the positive (+) lead from the battery to terminal 1 and the negative (-) lead to terminal 2.
- (b) Check that the motor turns (moves upward).

**NOTICE:** These tests must be performed quickly (within 3-5 seconds) to prevent the coil from burning out.

- (c) Then, reverse the polarity, check that the motor turns the opposite way (moves downward).

**NOTICE:** These tests must be performed quickly (within 3-5 seconds) to prevent the coil from burning out.

### 2. INSPECT ANTENNA MOTOR CONTROL RELAY

(Relay Circuit)

Disconnect the connector from the relay and inspect the connector on wire harness side as shown in the chart.

Check for	Tester connection	Condition		Specified value
Continuity	1 - 4	Constant		Continuity
	2 - Ground	Constant		Continuity
Voltage	3 - Ground	Constant		Battery positive voltage
	5 - Ground	Ignition switch position	LOCK	No voltage
			ACC or ON	Battery positive voltage
	6 - Ground	Ignition switch position	LOCK	No voltage
			ACC or ON	Radio switch and cassette OFF
				Radio switch or cassette ON
	8 - Ground	Ignition switch position	LOCK	No voltage
			ACC or ON	Radio switch OFF or cassette ON
		Radio switch ON and cassette OFF		Battery positive voltage
9 - Ground	Ignition switch position	LOCK or ACC		No voltage
		ON		Battery positive voltage

If circuit is as specified, replace the relay.

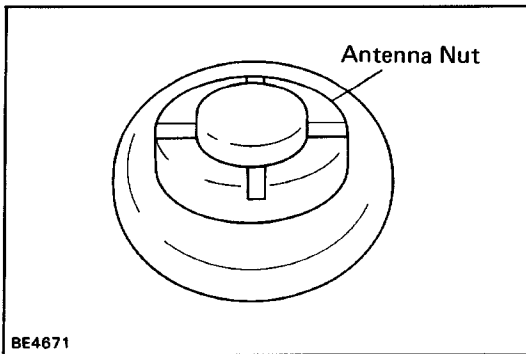

BE4671

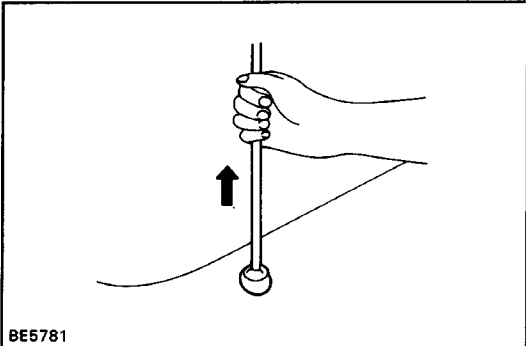

BE5781

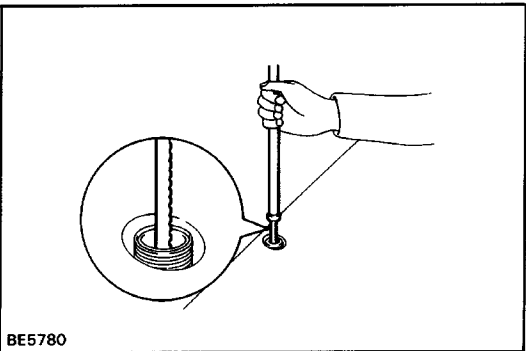

BE5780

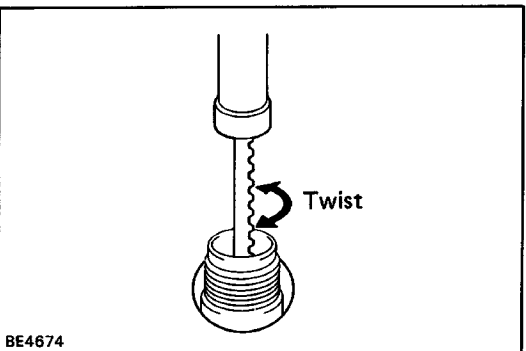

BE4674

## REMOVAL AND INSTALLATION OF ANTENNA ROD

### 1. REMOVE ANTENNA ROD

HINT: Perform this operation with the battery negative (-) cable connected to the battery terminal.

- (a) Turn the ignition switch to "LOCK" position.
- (b) Remove the antenna nut.

- (c) Press the "AM" button on the radio receiver, and simultaneously turn the ignition switch to "ACC" position.

HINT:

- The rod will extend fully and be released from the motor antenna.
- After removing the antenna rod, leave the ignition switch at "ACC".

### 2. INSTALL ANTENNA ROD

- (a) Insert the cable of the rod until it reaches the bottom.

HINT:

- When inserting the cable, the teeth on the cable must face toward the rear of the vehicle.
- Insert the antenna approx. 300 mm (11.8 in.)

- (b) Wind the cable to retract the rod by turning the ignition switch to "LOCK" position.

HINT:

- If the ignition switch is already in "LOCK" position, perform step 1
- (c) first, then turn the ignition switch to "ACC" position.
- In case the cable is not wound, twist it as shown in the illustration.
- Even if the rod has not retracted fully, install the antenna nut and inspect the antenna rod operation. It will finally retract fully.

- (c) Inspect the antenna rod operation by pushing the radio wave band select buttons.

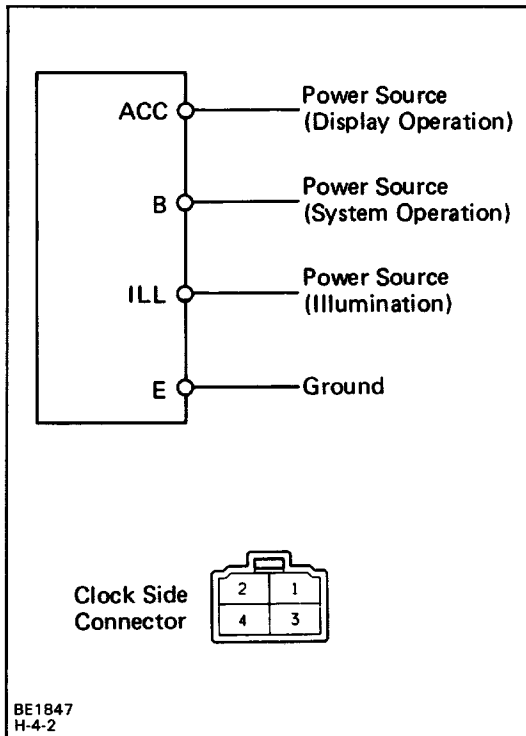

## CLOCK

### Troubleshooting

As shown in the illustration, those are clock circuit and connector diagrams. Inspect each terminal for applicable trouble.

Terminals		Condition	Specified value
1	E	Constant	Continuity
2	ILL	Turn light control switch ON	Battery positive voltage
3	B	Constant	
4	ACC	Turn ignition switch ACC	

Allowable error:  $\pm 1.5$  seconds/day

# BODY



## GENERAL INFORMATION

If there is a possibility the body and/or parts may be damaged, first remove the danger before performing repair operations.

Example:

1. Apply protection tape to the body adjacent to the body parts when removing and installing.

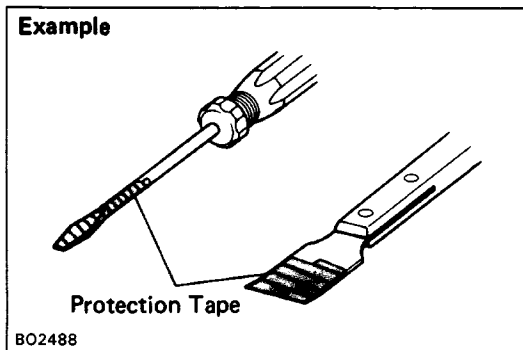

2. When prying off the body parts with a screwdriver or scraper etc., be sure to apply protection tape to the tip or blade to prevent damage to the paint film or body part.

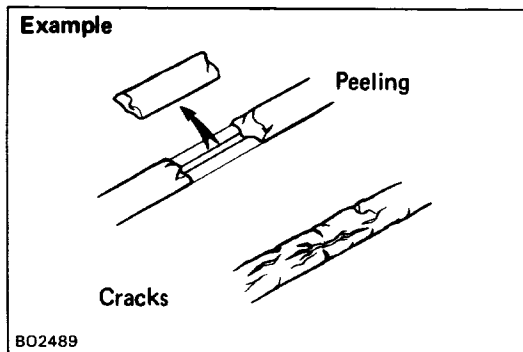

If anti-rust agents are damaged while repairing other parts, be sure to repair the anti-rust agent.

Example:

1. If body sealant, paint film or undercoat are damaged by peeling, cracks, etc., be sure to repair each with an anti-rust agent.

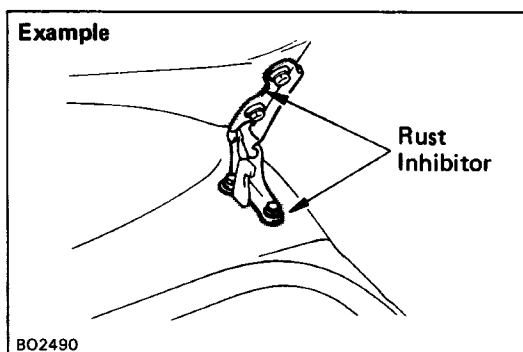

2. If a hinge or exterior body panel is loosened or removed, be sure apply rust inhibitor after repairs.

## HOOD

### ADJUSTMENT OF HOOD

HINT: Since the centering bolt is used as the hood hinge set bolt, the hood cannot be adjusted with it on. Substitute the bolt with the washer for the centering bolt.

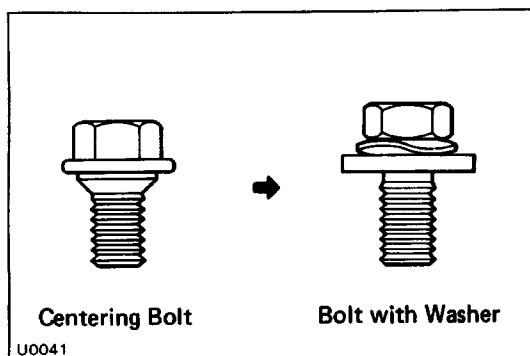

#### 1. ADJUST HOOD IN FORWARD /REARWARD AND LEFT/RIGHT DIRECTIONS

Adjust the hood by loosening the hood side hinge bolts.

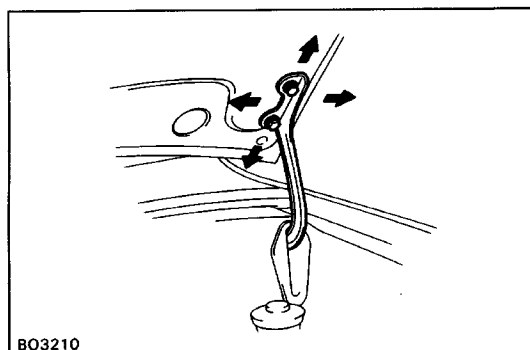

#### 2. ADJUST FRONT EDGE OF HOOD IN VERTICAL DIRECTION

Adjust the hood by turning the cushions.

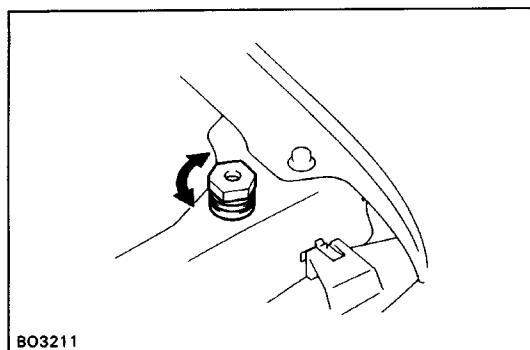

#### 3. REMOVE WIPER ARMS

#### 4. REMOVE COWL PANEL

Remove two clips, three screws and the cowl panel.

#### 5. ADJUST REAR EDGE OF HOOD IN VERTICAL DIRECTION

Adjust the hood by loosening the hood hinge bolts.

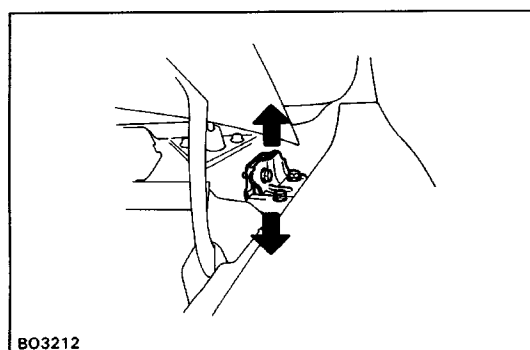

#### 6. ADJUST HOOD LOCK

Adjust the lock by loosening the bolts.

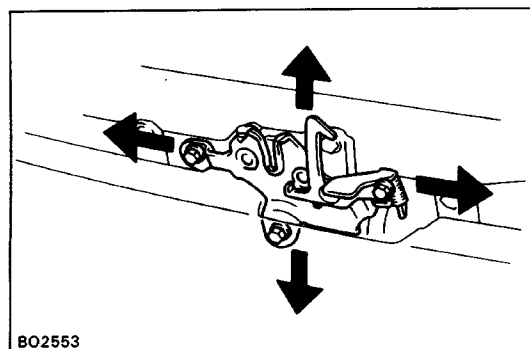

# FRONT DOOR COMPONENTS

w/o Ventilator Window Type

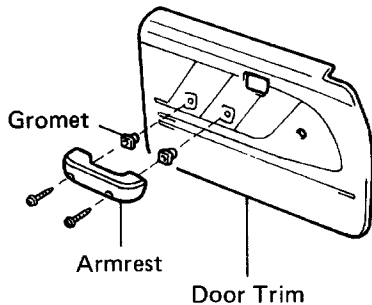
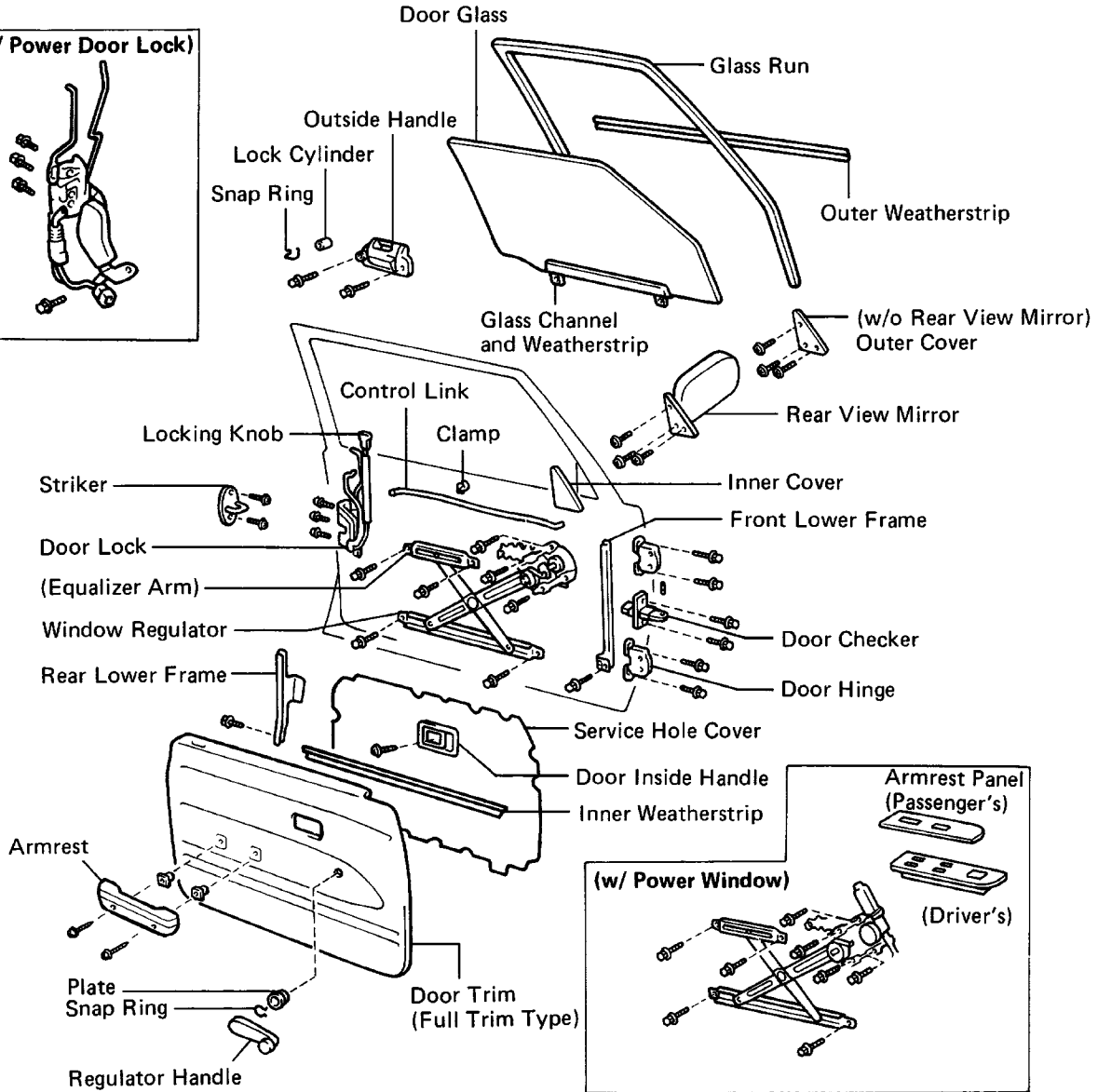

Semi Trim Type

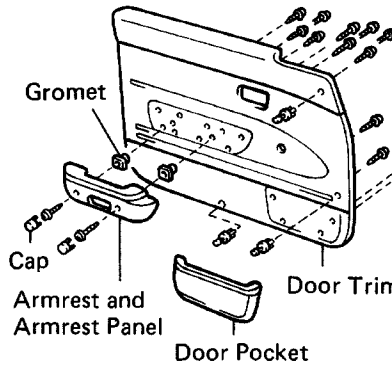

w/ Wide Armrest

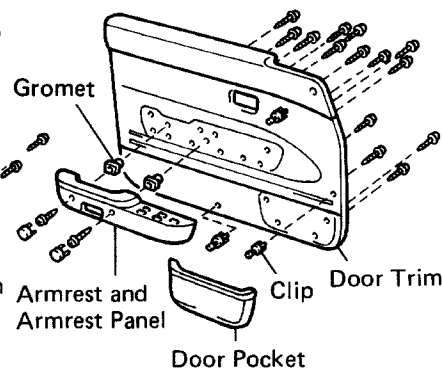

w/ Power Window

# COMPONENTS (Cont'd)

## w/ Ventilator Window Type

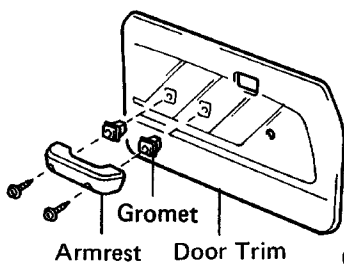
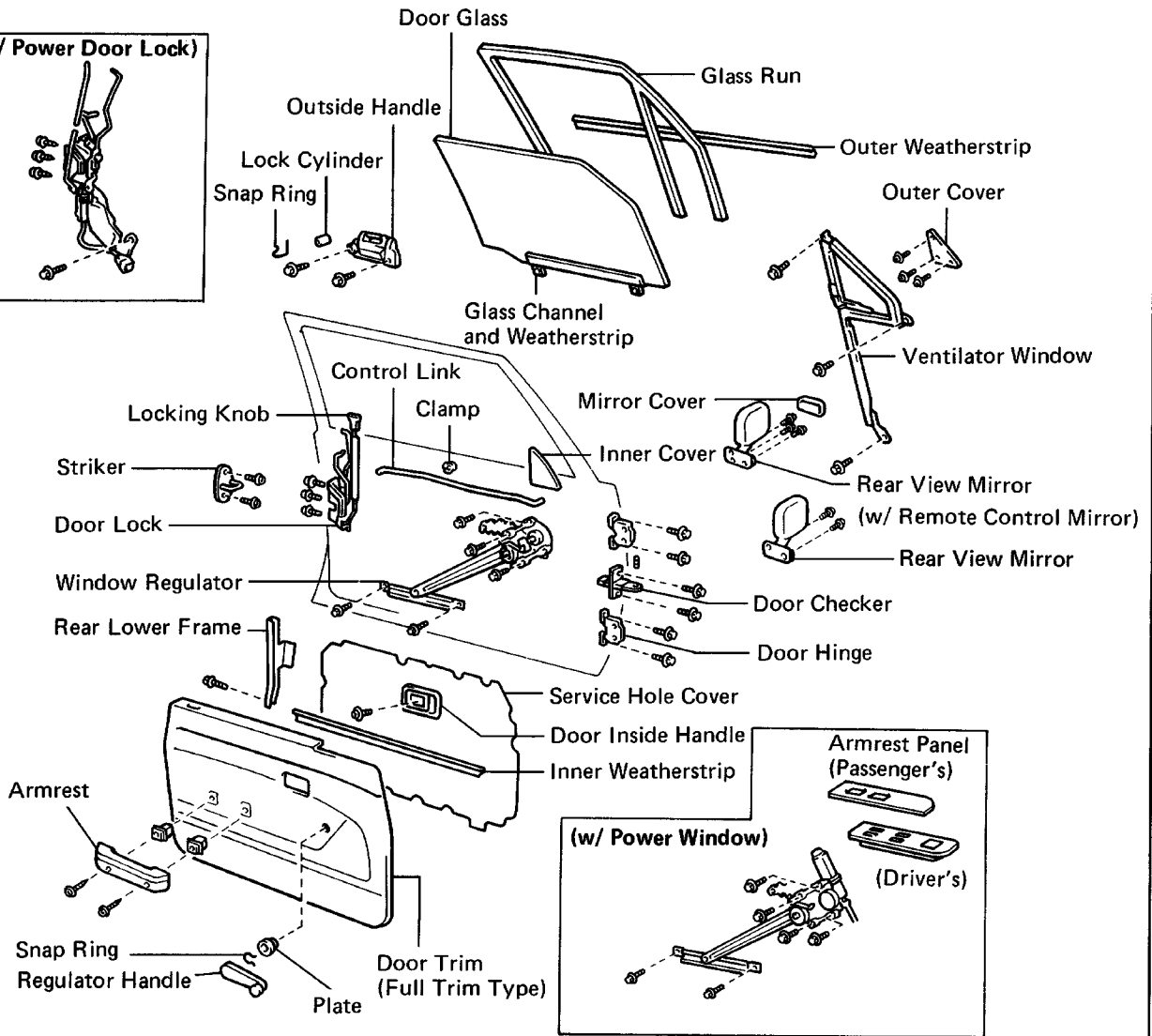
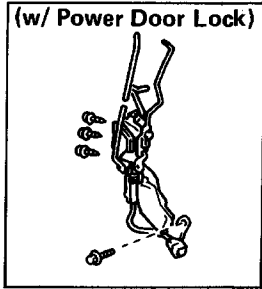

Semi Trim Type

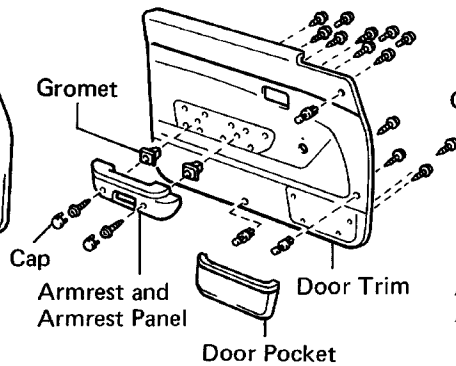

w/ Wide Armrest

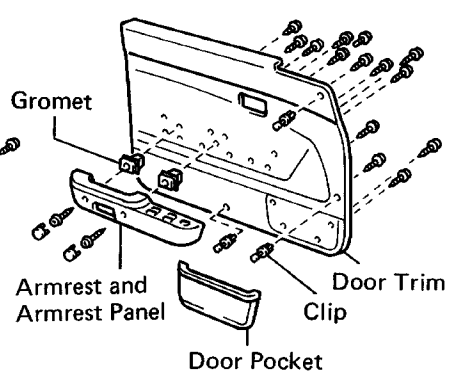

w/ Power Window

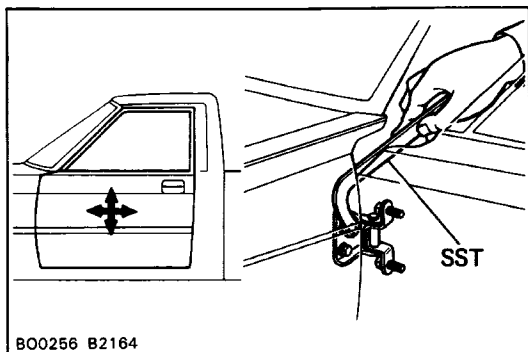

B00256 B2164

## ADJUSTMENT OF FRONT DOOR

### 1. ADJUST DOOR IN FORWARD/REARWARD AND VERTICAL DIRECTIONS

Using SST, adjust the door by loosening the body side hinge bolts.

SST 09812-00010

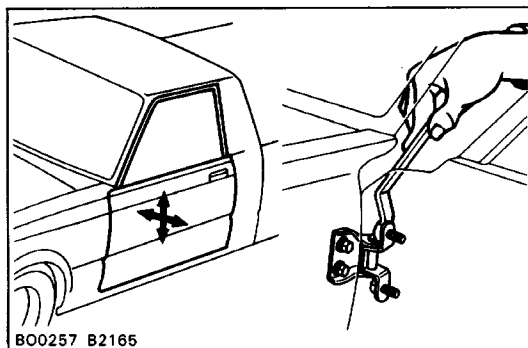

B00257 B2165

### 2. ADJUST DOOR IN LEFT/RIGHT AND VERTICAL DIRECTIONS

Loosen the door side hinge bolts to adjust.

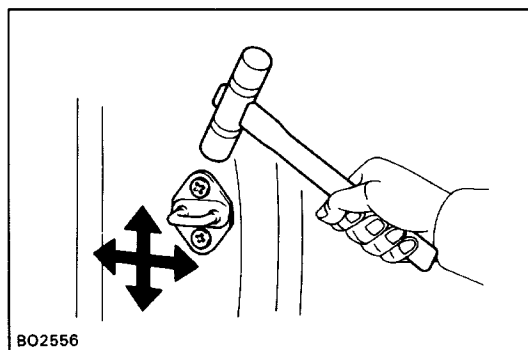

B02556

### 3. ADJUST DOOR LOCK STRIKER

- Check that the door fit and door lock linkages are adjusted correctly.
- Adjust the striker position by slightly loosening the striker mounting screws, and hitting the striker with a hammer.
- Tighten the striker mounting screws again.

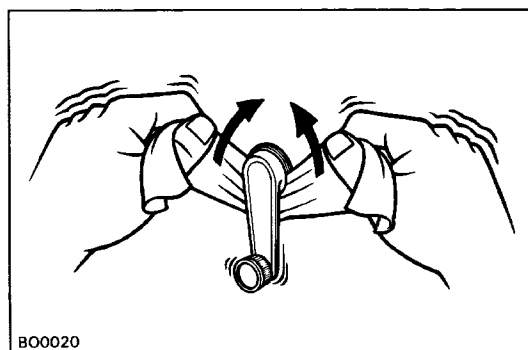

B00020

## DISASSEMBLY OF FRONT DOOR

(See pages [BO-4](#) and [5](#))

### 1. (w/o Power Window)

#### REMOVE REGULATOR HANDLE

Pull off the snap ring with a cloth and remove the regulator handle and plate.

### 2. REMOVE DOOR INSIDE HANDLE

- Remove the screw and slide the handle forward.
- Disconnect the handle from the control link and remove the handle.

### 3. REMOVE INNER AND OUTER COVERS

- Using a screwdriver, pry loose a clip and remove the inner cover.

HINT: Tape the screwdriver tip before use.

- (w/ Ventilator Window or w/o Rear View Mirror)  
Remove three screws and the outer cover.

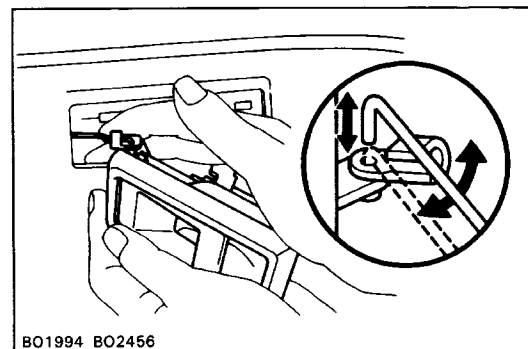

B01994 B02456

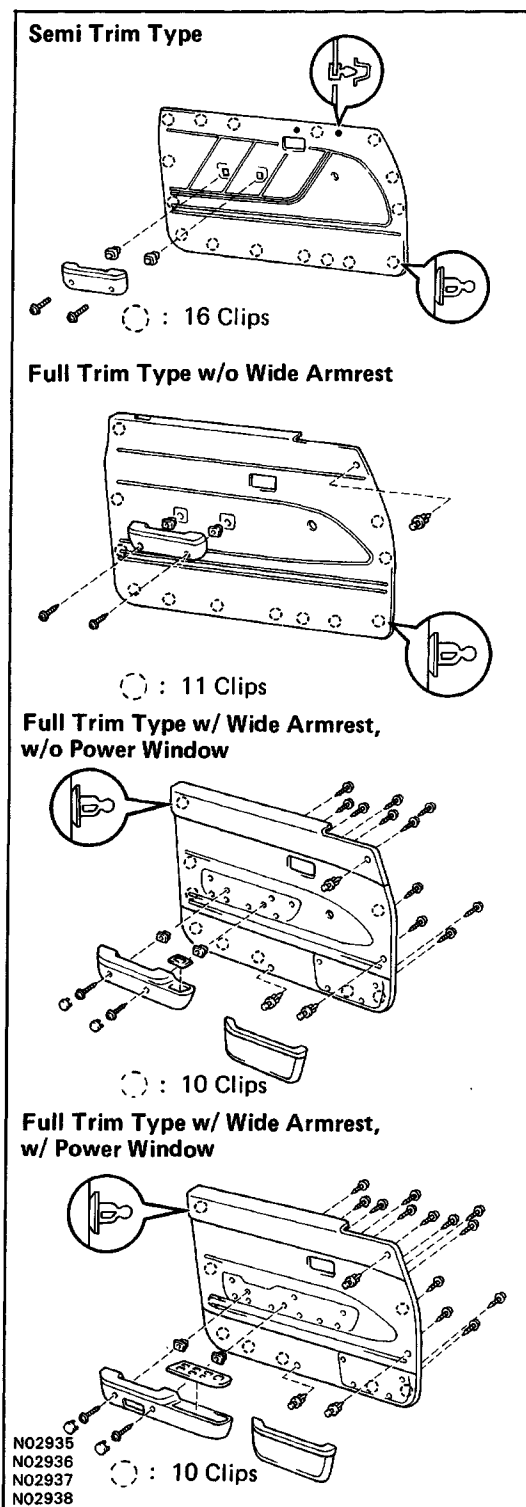

BO3220

#### 4. REMOVE REAR VIEW MIRROR (w/o Ventilator Window)

- (a) (w/Remote Control Mirror)  
Disconnect the connector.
- (b) Remove three screws and the mirror.

#### (w/ Ventilator Window)

- (a) (w/ Remote Control Mirror)  
Disconnect the connector.
- (b) (w/o Remote Control Mirror)  
Remove the mirror cover, two screws and the mirror.  
(w/ Remote Control Mirror)  
Remove the mirror cover, three screws and the mirror.

#### 5. REMOVE DOOR TRIM

- (a) (w/ Wide Armrest)  
Remove two caps from the armrest.
- (b) (w/ Wide Armrest)  
Remove two screws from the armrest.  
(Semi Trim Type and Full Trim Type, w/ Wide Armrest)  
Remove two screws and the armrest.
- (c) (w/ Power Window)  
Remove the armrest panel by pulling upward, then disconnect the connectors.
- (d) (w/ Wide Armrest)  
Remove three clips.  
(Full Trim Type, w/o Wide Armrest)  
Remove the clip.
- (e) Install the screwdriver between the retainers and door trim to pry it loose.

HINT: Tape the screwdriver tip before use.

- (f) Remove the door trim.
- (g) (w/ Power Window)  
Remove nine screws and the armrest.  
(w/ Wide armrest, w/o Power Window)  
Remove seven screws and the armrest.
- (h) (w/ Wide Armrest)  
Remove four screws and the door pocket.
- (i) (Full Trim Type)  
Remove the inner weatherstrip from the door trim.

#### 6. REMOVE SERVICE HOLE COVER

##### 7-1. (w/ Ventilator Window)

##### REMOVE VENTILATOR WINDOW

- (a) Remove the bolt and two screws.
- (b) Remove the ventilator window by pulling it upward.

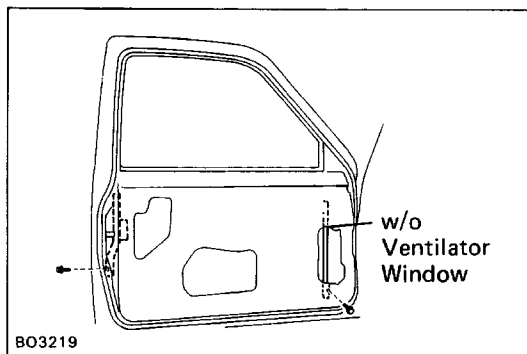
**7-2. (w/o Ventilator Window)****REMOVE FRONT LOWER FRAME**

Remove the bolt and the frame.

**8. REMOVE REAR LOWER FRAME**

Remove the bolt and the frame.

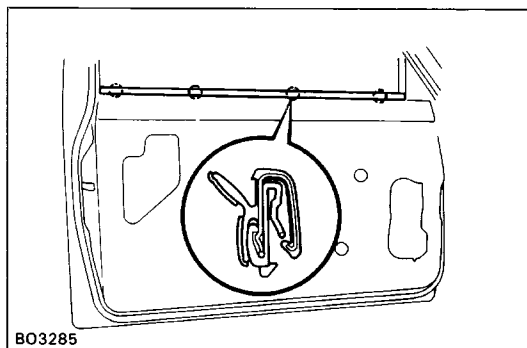
**9-1. (Semi Trim type)****REMOVE INNER AND OUTER WEATHERSTRIP**

Pry loose the clips from the edge of the panel and remove the weatherstrip.

**9-2. (Full Trim type)****REMOVE OUTER WEATHERSTRIP**

In the same manner, remove the outer weatherstrip.

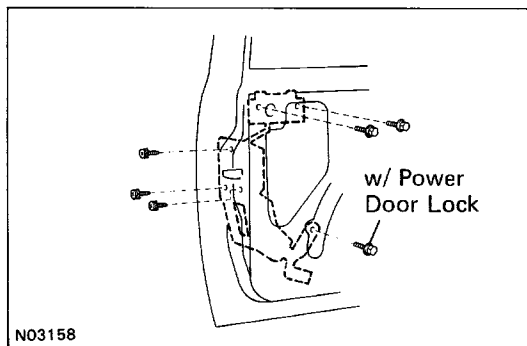
**10. REMOVE GLASS RUN****11. REMOVE INSIDE LOCKING KNOB**

Disconnect the link and remove the inside locking knob.

**12. REMOVE OUTSIDE HANDLE WITH LOCK CYLINDER AND DOOR LOCK**

(a) Disconnect the links from the outside handle with the lock cylinder.

(b) (w/Power Door Lock)

Disconnect the connectors, remove three screws, the bolt and the door lock with the motor.

(w/o Power Door Lock)

Remove three screws and the door lock.

(c) Remove two bolts and the outside handle with lock cylinder.

(d) Remove the snap ring and the lock cylinder.

**13. REMOVE DOOR GLASS AND WINDOW REGULATOR**

(a) Remove two glass channel mounting bolts.

(b) Place the glass in the door cavity.

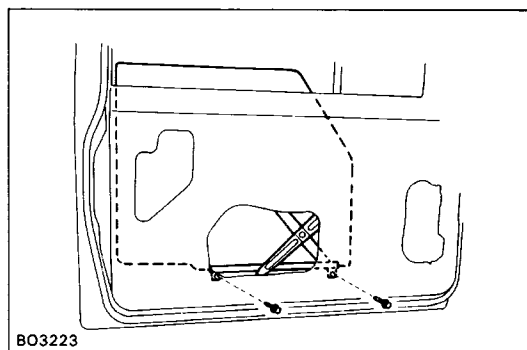

(c) (w/o Ventilator Window)

Remove two equalizer arm bracket mounting bolts.

(d) (w/ Power Window)

Disconnect the connectors, then remove four regulator mounting bolts.

(w/o Power Window)

Remove three regulator mounting bolts.

(e) Remove the regulator through the service hole.

(f) Remove the glass by pulling it upward.

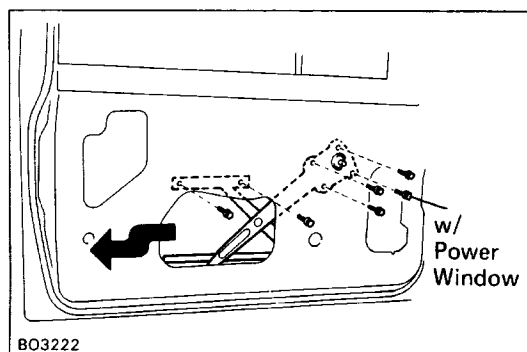

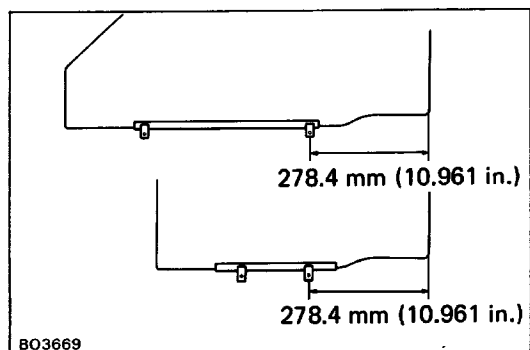

## REPLACEMENT OF GLASS

1. REMOVE GLASS CHANNEL WITH SCREWDRIVER OR LIKE OBJECT
2. APPLY SOAPY WATER TO INSIDE OF WEATHER-STRIP
3. INSTALL CHANNEL BY TAPPING IT WITH PLASTIC HAMMER

## ASSEMBLY OF FRONT DOOR

(See pages [BO-4](#) and 5)

1. BEFORE INSTALLING PARTS, COAT THEM WITH MP GREASE

(a) Apply MP grease to the sliding surface and the gears of the window regulator.

**NOTICE:** Do not apply MP grease to the spring of the window regulator.

(b) Apply MP grease to the sliding surface of the door lock.

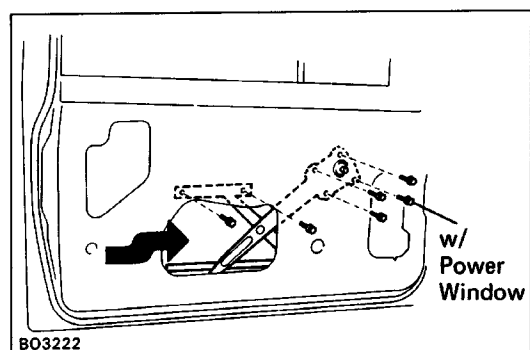
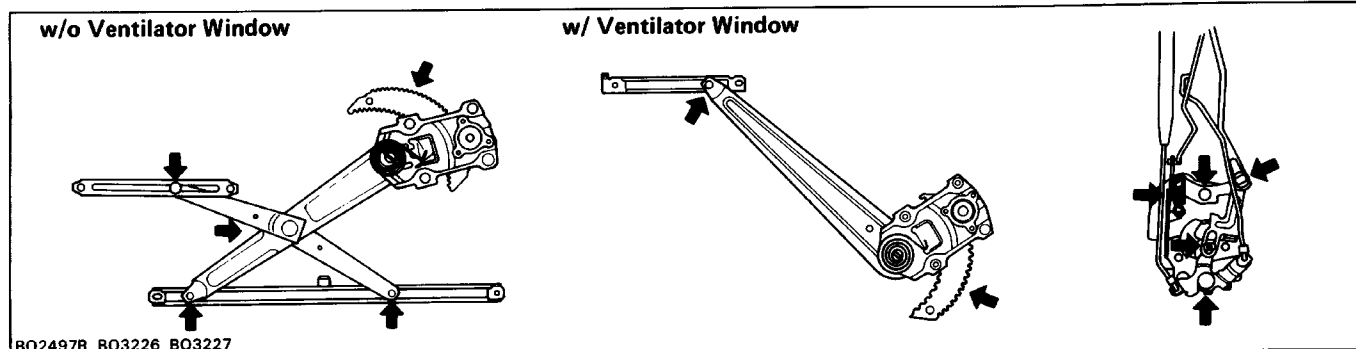

2. INSTALL WINDOW REGULATOR AND DOOR GLASS

(a) Place the glass in the door cavity.

(b) Place the regulator through the service hole.

(c) (w/ Power Window)

Install the four regulator mounting bolts, then connect the connector.

(w/o Power Window)

Install the three regulator mounting bolts.

(d) (w/o Ventilator Window)

Install the equalizer arm and temporarily tighten two equalizer arm mounting bolts.

(e) Attach the glass to the window regulator with two bolts.

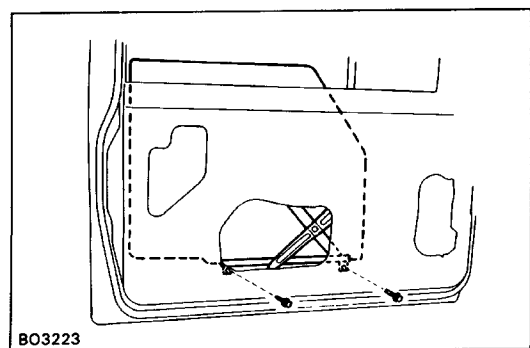



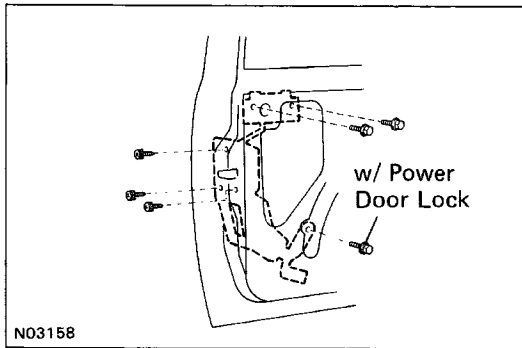

### 3. INSTALL OUTSIDE HANDLE WITH LOCK CYLINDER AND DOOR LOCK

- Install the lock cylinder with the snap ring to the outside handle.
- Install the outside handle and lock cylinder with two bolts.
- (w/Power Door Lock)  
Install the door lock and motor with three screws and the bolt, then connect the connector.  
(w/o Power Door Lock)  
Install the door lock with three screws.
- Connect the links to the outside handle.

### 4. INSTALL INSIDE LOCKING KNOB

Install the locking knob and connect the control links.

### 5. INSTALL GLASS RUN

### 6. INSTALL REAR LOWER FRAME

#### 7-1. (w/o Ventilator Window)

#### INSTALL FRONT LOWER FRAME

#### 7-2. (w/Ventilator Window)

#### INSTALL VENTILATOR WINDOW

- Install the ventilator window.
- Install the bolt and two screws.

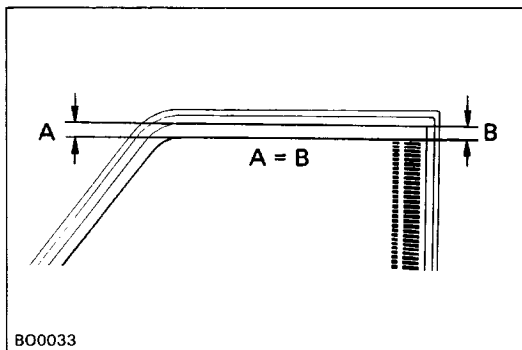
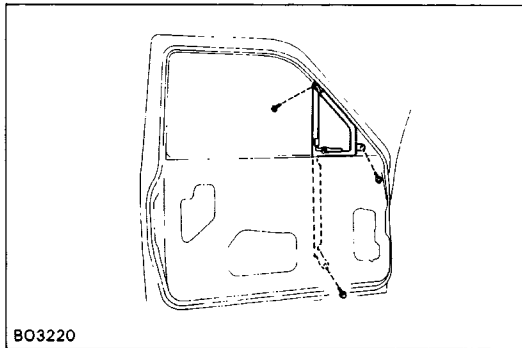
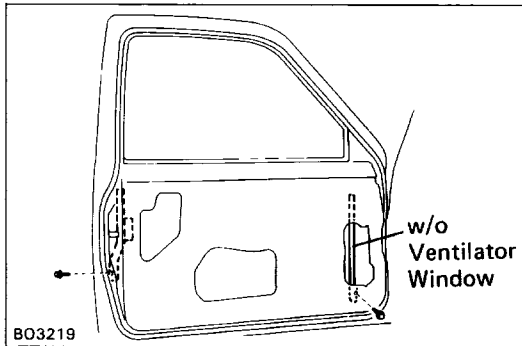

### 8. (w/o Ventilator Window) ADJUST DOOR GLASS

Adjust the equalizer arm up or down and tighten if where dimensions A and B, as shown are equal.

### 9. INSTALL REAR VIEW MIRROR

### 10. INSTALL INNER AND OUTER COVERS

### 11. INSTALL SERVICE HOLE COVER

- Seal the service hole cover with adhesive.
- Install the lower edge of the service hole cover into the panel slit.

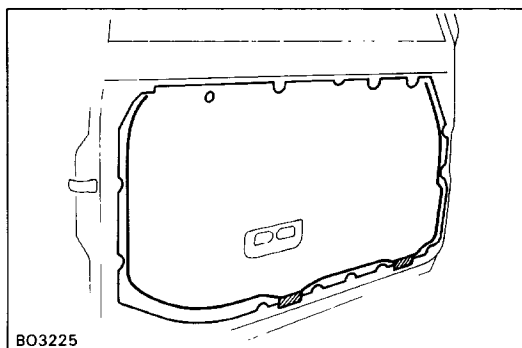

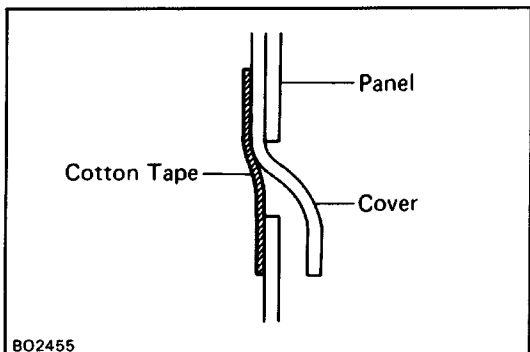

(c) Seal the panel slit with the cotton tape.

**NOTICE: Do not block the trim clip seating with the tape.**

**12-1.(Semi Trim type)**

**INSTALL OUTER AND INNER WEATHERSTRIP**

Install the claw of the clips into the upper panel slit and push the weatherstrip onto the panel.

**12-2.(Full Trim type)**

**INSTALL OUTER WEATHERSTRIP**

In the same manner, install the outer weatherstrip.

**13. INSTALL THE DOOR TRIM**

(a) (Full Trim Type)

Install the inner weatherstrip to the door trim.

(b) (w/ Wide Armrest)

Install the door pocket with four screws to the door trim.

(c) (w/Power Window)

Install the armrest with nine screws to the door trim.

(w/ Wide Armrest, w/o Power Window)

Install the armrest with seven screws to the door trim.

(d) Install the door trim with retainers to the inside panel by tapping.

(e) (w/ Power Window)

Connect the connectors and install the armrest panel.

(f) (w/ Wide Armrest)

Install three clips.

(Full Trim Type, w/o Wide Armrest)

Install the clip.

(g) (w/ Wide Armrest)

Install two screws to the armrest.

(Semi Trim Type and Full Trim Type, w/ Wide Armrest)

Install the armrest with two screws.

(h) (w/ Wide Armrest)

Install two caps to the armrest.

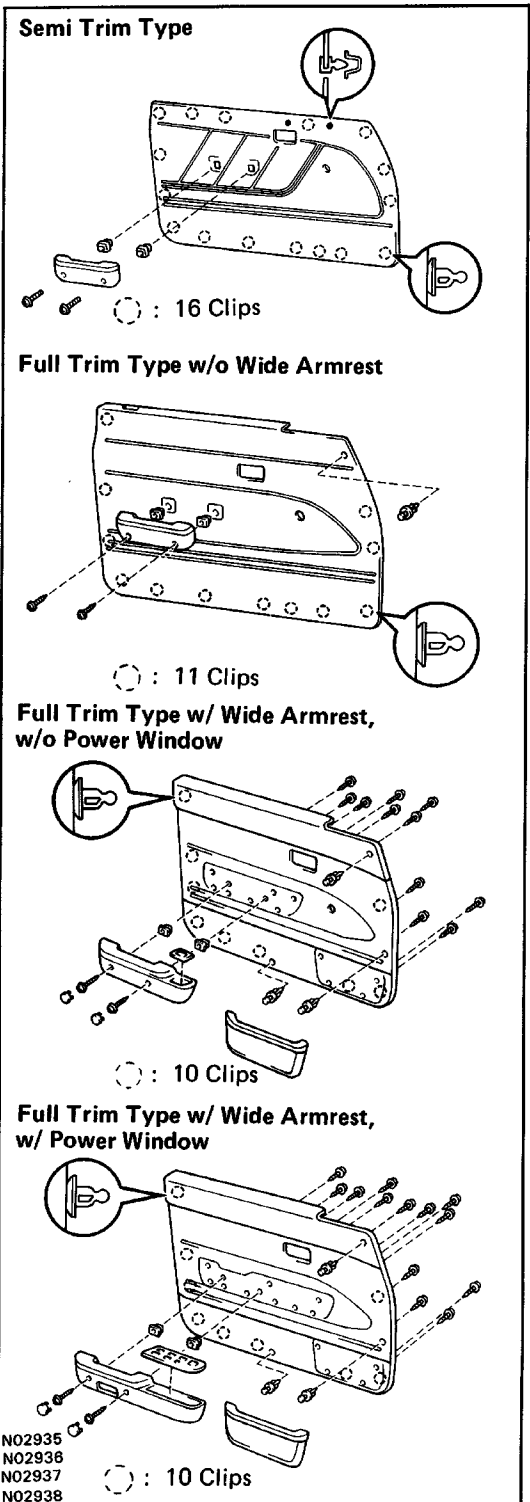

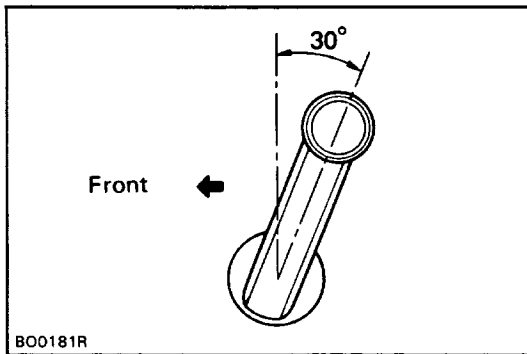
**14. INSTALL DOOR INSIDE HANDLE**

(See step 2 on page [BO-6](#))

- (a) Connect the handle to the control links.
- (b) Push the inside handle in the door panel and slide it rearward.
- (c) Install the screw.

**15. (w/o Power Window)****INSTALL REGULATOR HANDLE**

With door window fully closed, install the plate and the regulator handle with the snap ring as shown.

# MOULDING

## Windshield Moulding

### COMPONENTS

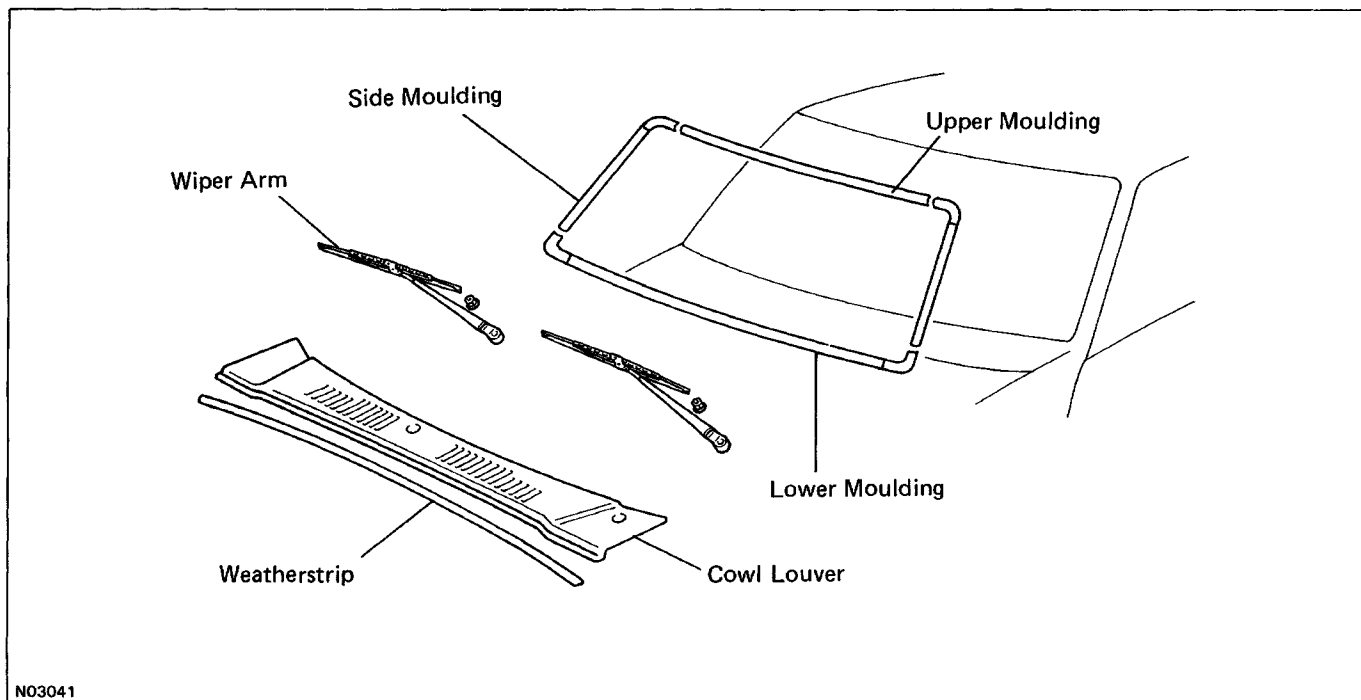

N03041

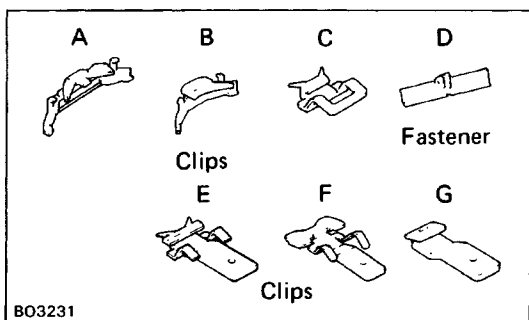

B03231

## REMOVAL OF WINDSHIELD MOULDING

### LOCATION OF CLIPS AND FASTENER

- For vehicles in the table below which have black moulding, refer to diagram type 1.
- For other vehicles which have black or metallic moulding, refer to diagram Type 11.
- However, if all clips and fasteners are replaced, either diagram Type I or Type 11 may be referred to.

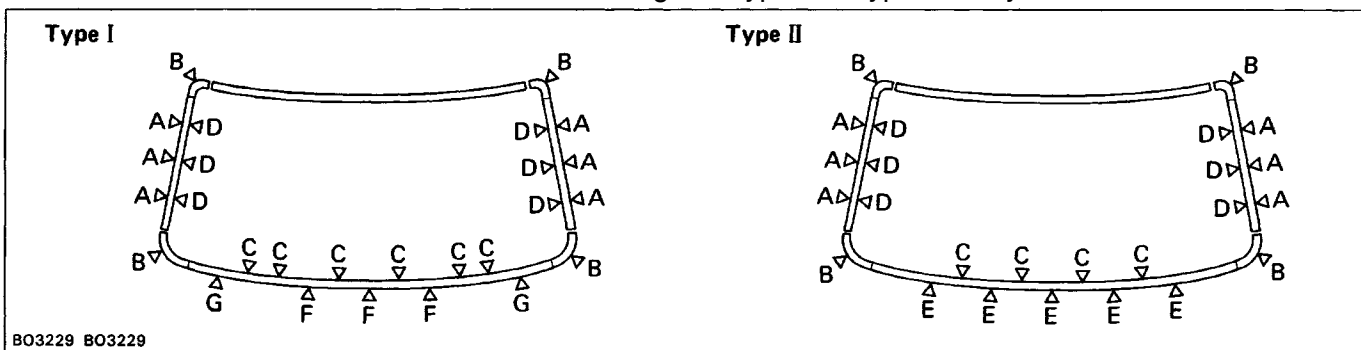

B03229 B03229

### Type I Applicable Models

Frame No.	Vehicle Code	Frame No.	Vehicle Code
0000001 ~ 1999999	VZN 100, VZN 105	0000001 ~ 6999999	RN101, RN106
0000001 ~ 4999999	RN80, RN85, RN90 VZN80, VZN85, VZN90, VZN 110	0000001 ~ 9999999	VZN95
		6000000 ~ 9999999	VZN100, VZN105
0000001 ~ 5999999	RN110	-	-

**1. REMOVE WIPER ARMS**  
**2. REMOVE COWL LOUVER AND WEATHERSTRIP**  
**3. REMOVE LOWER MOULDING WITH LOWER JOINT COVERS**

- (a) Remove five screws from the clips.  
 (b) Pry up a scraper to loosen the clips from the body.  
 HINT: Tape the scraper tip before use.  
 (c) Remove the moulding with lower joint covers and clips.

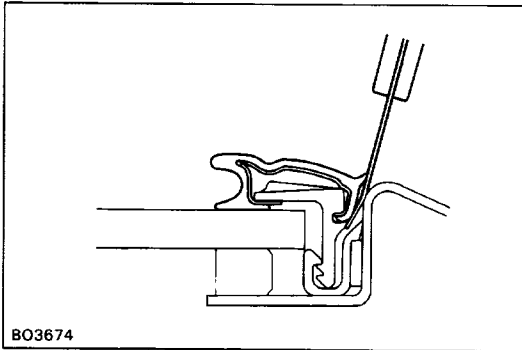

**4. REMOVE SIDE MOULDING WITH UPPER JOINT COVERS**

- (a) Install the tip of a scraper between the body and moulding.  
 HINT: Tape the scraper tip before use.  
 (b) Pry up the scraper to loosen the moulding from the claws of the clips and fasteners.  
 (c) Remove the moulding with upper joint covers.

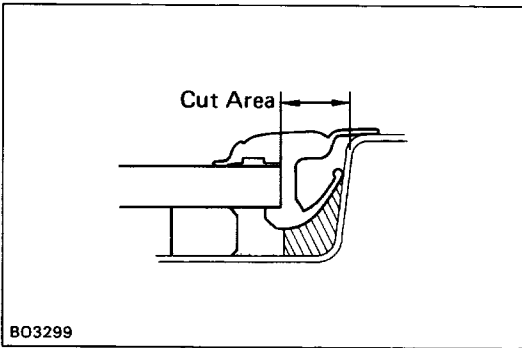

**5. REMOVE UPPER MOULDING**

- (a) Using a knife, cut off the upper moulding as shown.  
 (b) Cut off the old adhesive around the upper moulding installation area.

**NOTICE: Do not damage the body and glass.**

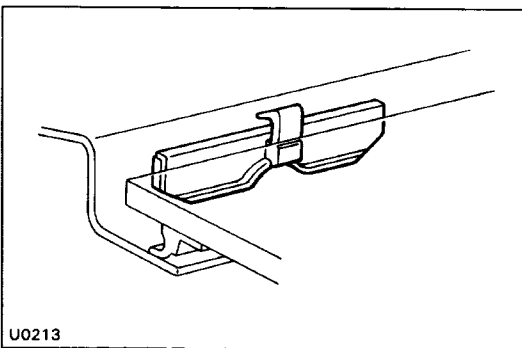

**REPLACEMENT OF FASTENER**  
**REPLACE FASTENER**

- (a) Remove the damaged fastener.  
 (b) Cut off the old adhesive around the fastener installation area.  
**NOTICE: Be carefully not to damage the body.**  
 (c) Clean the installation area.  
 (d) Install new fastener onto the body.

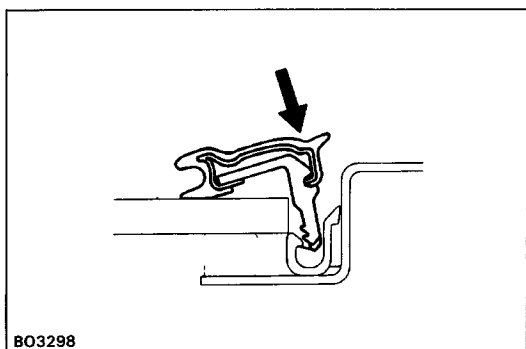
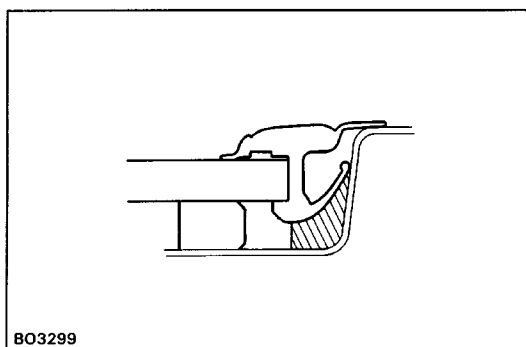
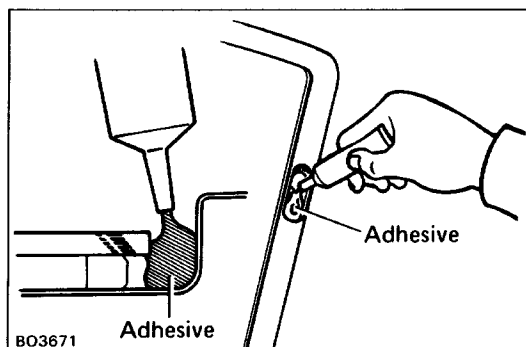

## INSTALLATION OF WINDSHIELD MOULDING

### 1. INSTALL CLIP INTO MOULDING

(See page [BO-13](#))

Install the clip to the appropriate place on the moulding.

### 2. APPLY ADHESIVE AT CLIP INSTALLATION AREA

(a) Cut out the old adhesive around the clip installation area.

**NOTICE: Do not damage the body and fastener.**

(b) Apply adhesive at the clip installation area so water does not collect there.

### 3. APPLY ADHESIVE AT UPPER MOULDING INSTALLATION AREA

### 4. INSTALL NEW UPPER MOULDING

Place the moulding onto the body and tap it by hand.

### 5. INSTALL SIDE MOULDING WITH UPPER JOINT COVERS

(a) Place the moulding with upper joint covers onto the body.

(b) Tap the moulding by hand to install it.

(c) Pry up the clips on the body side, and install them to the moulding.

### 6. INSTALL LOWER MOULDING WITH LOWER JOINT COVERS

(a) Place the moulding with lower joint covers onto the body.

(b) Align the clips of the moulding with the body holes, and push the moulding on the body.

### 7. INSTALL COWL LOUVER AND WEATHERSTRIP

(See page [BO-13](#))

### 8. INSTALL WIPER ARMS

(See page [BO-13](#))

## Wheel Arch Moulding COMPONENTS

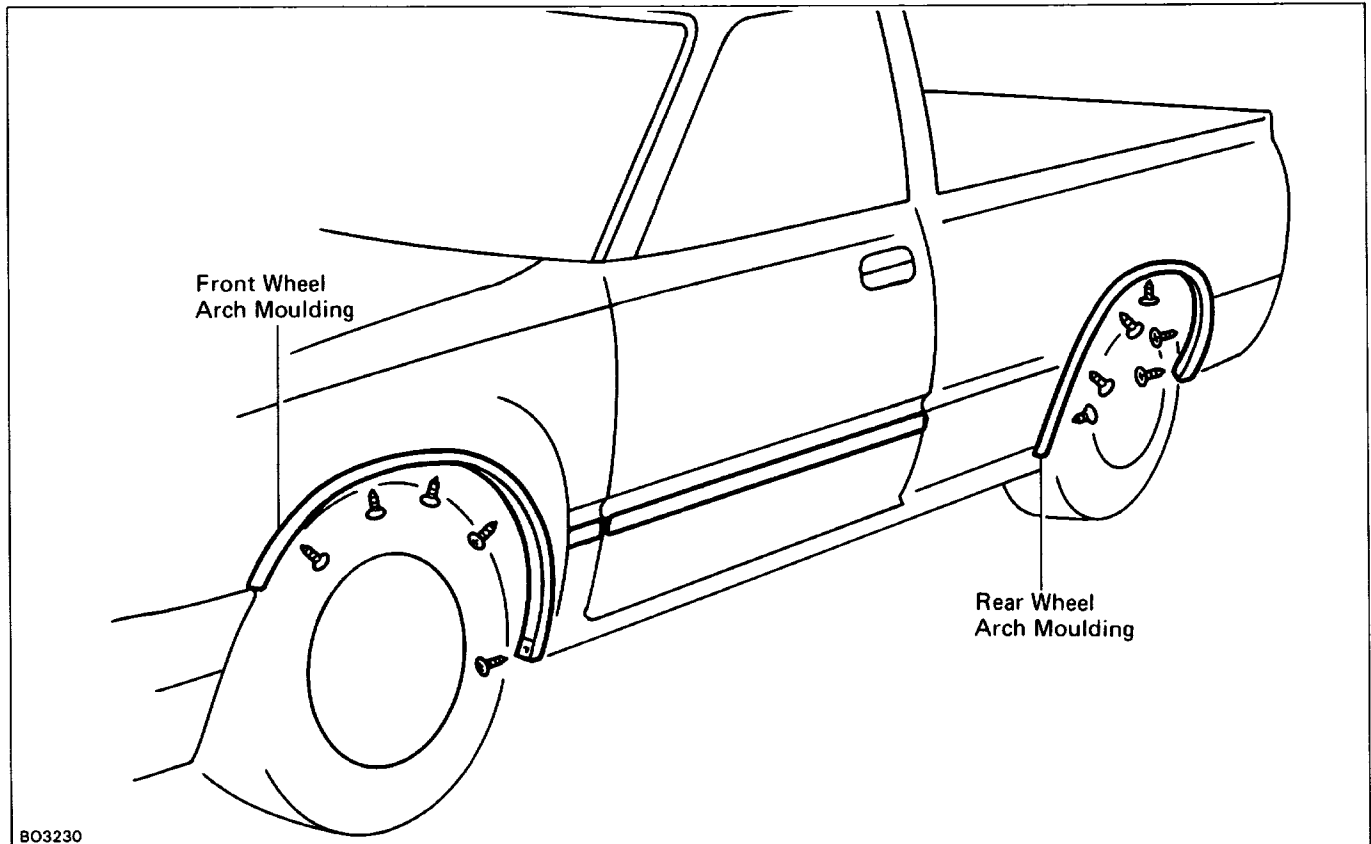

### REPLACEMENT OF FRONT WHEEL ARCH MOULDING

#### 1. REMOVE FRONT WHEEL ARCH MOULDING

- (a) Remove five screws.
- (b) Using a screwdriver, pry up the wheel arch moulding, and remove it.

HINT: Tape the screwdriver tip before use.

#### 2. INSTALL FRONT WHEEL ARCH MOULDING

- (a) Tap the wheel arch moulding by hand to install it.
- (b) Install five screws.

### REPLACEMENT OF REAR WHEEL ARCH MOULDING

#### 1. REMOVE REAR WHEEL ARCH MOULDING

- (a) Remove six screws.
- (b) Using a screwdriver, pry up the wheel arch moulding, and remove it.

HINT: Tape the screwdriver tip before use.

#### 2. INSTALL REAR WHEEL ARCH MOULDING

- (a) Tap the wheel arch moulding by hand to install it.
- (b) Install six screws.

# WINDSHIELD (Adhesive Type) PREPARE ITEMS LISTED

Part name and No.	Contents of set	Quantity
Adhesive set 08850-00070 (0 - 150C or 32 - 59°F) 08850-00080 (15 - 351C or 59 - 951F) 08850-00090 (35 - 450C or 95 - 1131F)	Main agent 500g (17.64 oz.) hardening agent 75g (2.65 oz.) Primer G (for glass) 20g (0.71 oz.) Primer M (for body) 20g (0.71 oz.) Sponge (for applying primer) Piano wire 0.6 mm dia. x 1 m (0.024 x 39.37 in.) Cartridge	1 1 1 1 2 1 1
Dam kit 04562-30040	Dam Double-stick tape (for sticking on dam)	
	Sealant gun (for applying adhesive) Glass or steel sheet (for mixing adhesive) Putty spatula (for mixing adhesive and correcting adhered parts) Cleaner (for cleaning adhering surface)	

Ambient temperature	Part No.	Part name
0 - 15°C (32 - 59°F)	08850-00070	Windshield glass adhesive set No. 15
15 - 35°C (59 - 95°F)	08850-00080	Windshield glass adhesive set No. 35
35 - 45°C (95 - 113°F)	08850-00090	Windshield glass adhesive set No. 45

### 1. CHOOSE SUITABLE ADHESIVE SET

Use an adhesive set suitable for the ambient temperature.

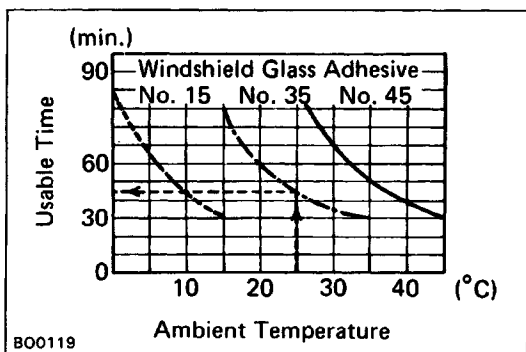

### 2. CHECK ADHESIVE USABLE TIME

After mixing the main and hardening agents, finish glass installation within the specified time as shown.

Example: For glass installation in ambient temperature of 25°C (77°F), apply adhesive set No.35 within 45 minutes.

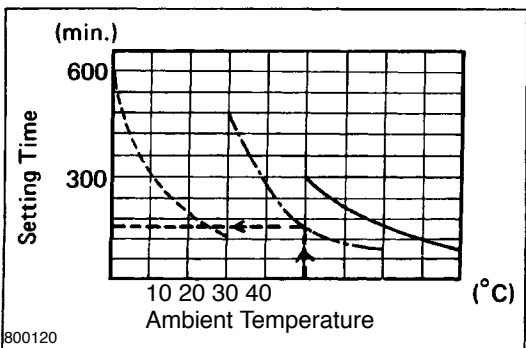

### 3. CHECK ADHESIVE SETTING TIME

First, mix the main and hardening agents. Then, perform a leak test only after the setting time has elapsed.

Example: The setting time for adhesive set No.35 with an ambient temperature of 25°C (77°F) is 2.5 hours.

**NOTICE: Do not drive the vehicle until at least double the setting time has elapsed.**

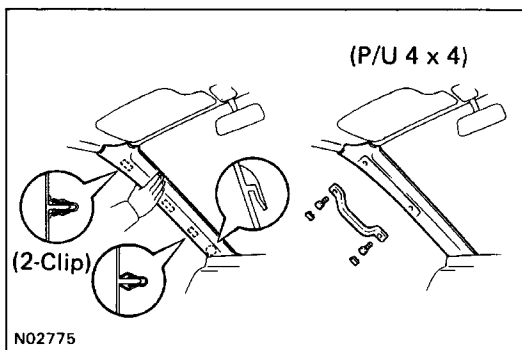
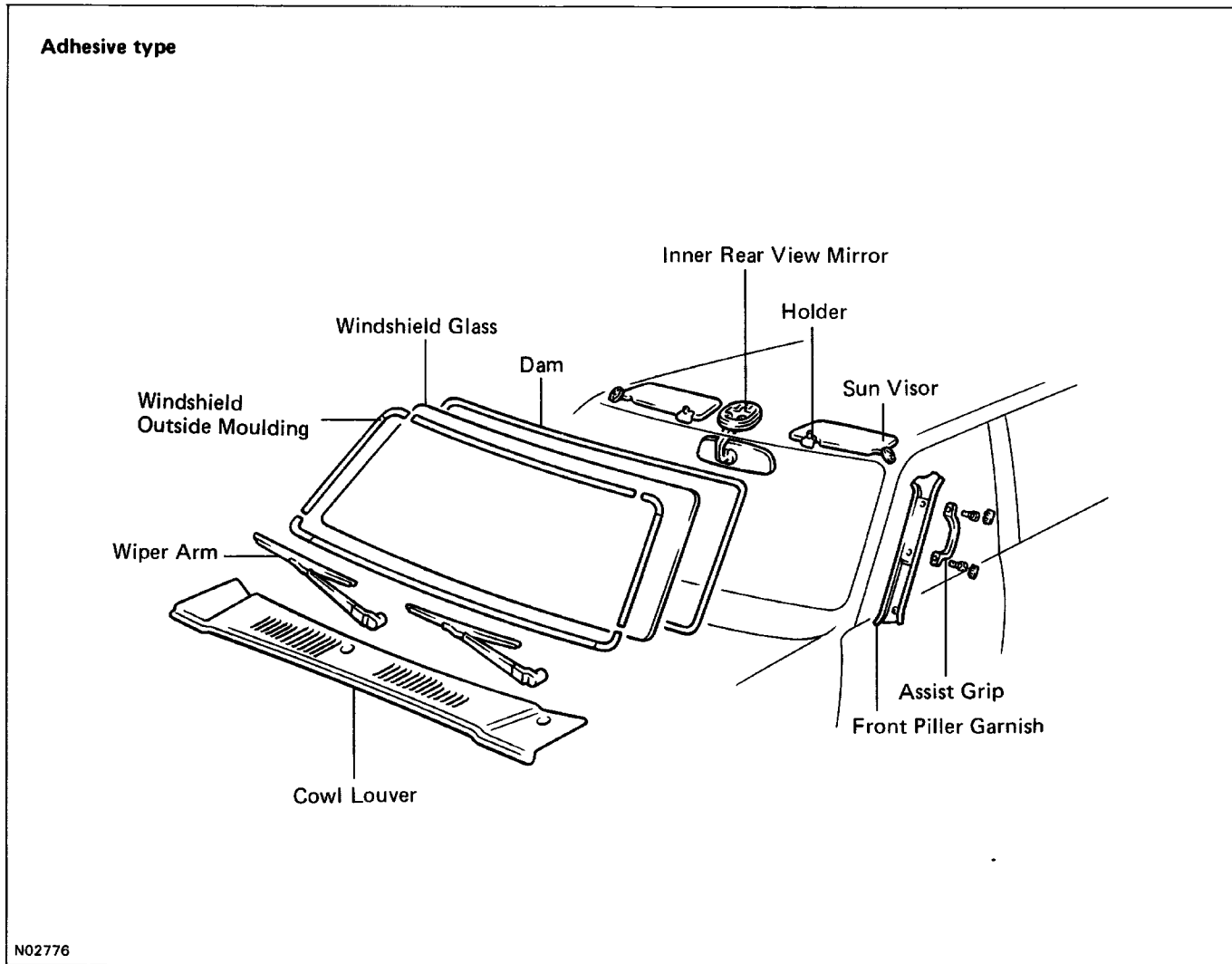

## COMPONENTS

**REMOVAL OF WINDSHIELD****1. REMOVE FOLLOWING PARTS:**

- Inner rear view mirror
- Sun visors and holders
- Wiper arms
- Cowl louver
- Front pillar garnishes
- Assist grip

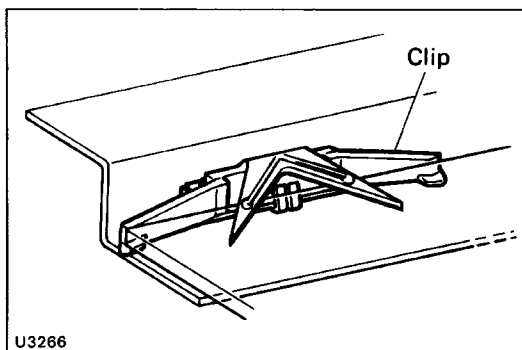
**2. REMOVE WINDSHIELD MOULDING**(See page [BO-13](#))**3. REMOVE CLIPS**

Be careful not to damage the side moulding clips, when removing them from around the glass.

HINT: It is not necessary to remove the fasteners but any damaged fasteners should be replaced.

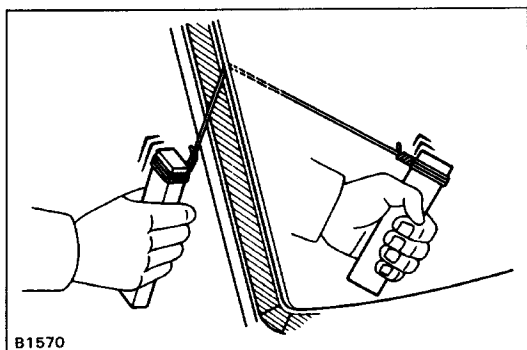

B1570

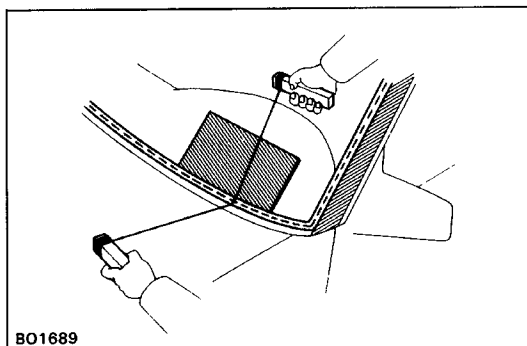

BO1689

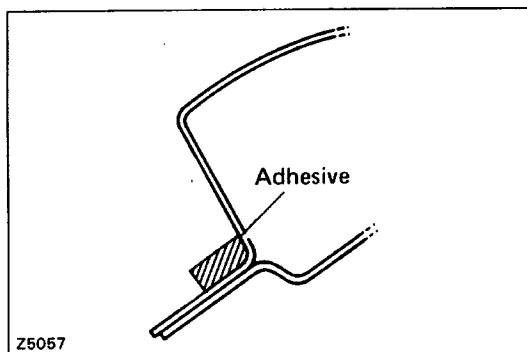

Z5057

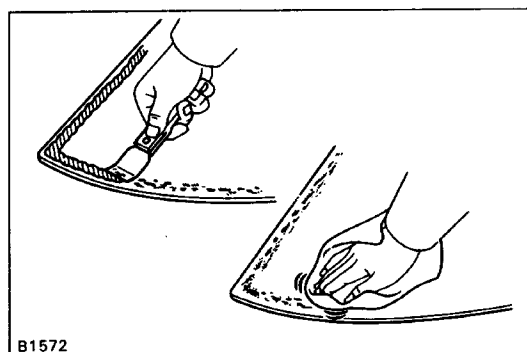

B1572

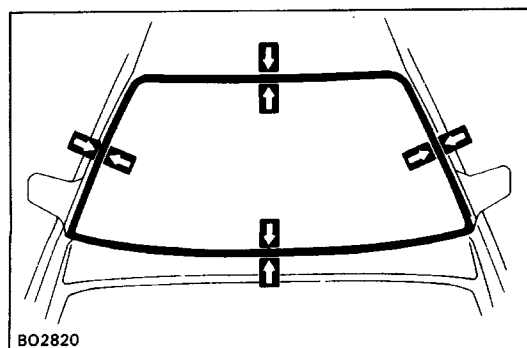

BO2820

#### 4. REMOVE WINDSHIELD GLASS

- (a) Push piano wire through from the interior.
- (b) Tie both wire ends to the wooden blocks or like objects.

HINT: Apply adhesive tape to the outer surface to keep the surface from being scratched.

**NOTICE: When separating, take care not to damage the paint and interior and exterior ornaments.**

To prevent scratching the safety pad when removing the windshield, place a plastic sheet between the piano wire and safety pad.

Cut the adhesive by pulling the piano wire around it.

- (d) Remove the glass.

**NOTICE: Leave as much of the adhesive layer on the body as possible when cutting off the glass.**

### PREPARATION FOR INSTALLATION

#### 1. CLEAN AND SHAPE CONTACT SURFACE OF BODY

- (a) Remove any dam remaining on the body.
- (b) Cut away any rough areas with a knife.

HINT: Leave as much of the adhesive layer on the body as possible.

- (c) Clean the cutting surface of the adhesive with a piece of cloth saturated in cleaner.

HINT: Even if all the adhesive has been removed, clean the body.

#### 2. IF NECESSARY, REPLACE FASTENERS

(See page [BO-14](#))

#### 3. CLEAN REMOVED GLASS BEFORE INSTALLATION

- (a) Using a scraper, remove the adhesive sticking to the glass.
- (b) Using the cleaner, clean the glass.

#### 4. POSITION GLASS

- (a) Place the glass in correct position.
- (b) Check that all contacting parts of the glass rim are perfectly even, and do not make contact with the fasteners.
- (c) Mark reference marks between the glass and body.
- (d) Remove the glass.

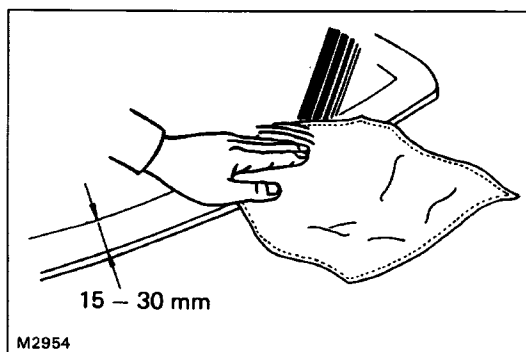

## INSTALLATION OF WINDSHIELD

(See pages [BO-13](#) and 18)

### 1. CLEAN CONTACT SURFACE OF GLASS

Using cleaner, clean the contact surface 15 – 30 mm (0.59 – 1.18) wide around the entire glass rim.

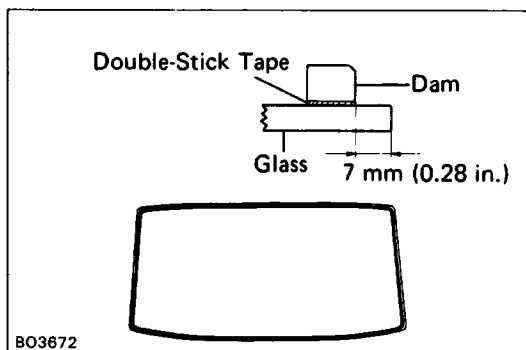

### 2. INSTALL DAM

(a) Apply double-stick tape at a point as shown.

(b) Place the dam on the double-stick tape.

**NOTICE:** Do not touch the glass face after cleaning it.

### 3. COAT CONTACT SURFACE OF BODY WITH PRIMER "M"

Using a brush, coat the contact surface on the body with Primer M.

**NOTICE:**

- Let the Primer coating dry for 10 minutes or more. Make sure that the installation of the glass is finished within 2 hours.
- Use care not to leave any part of the contact surface uncoated or excessively coated, as Primer M and G serve to boost the adhesive power of the adhesive to the glass or body.
- Do not keep any of the opened Primer M and G for later use.

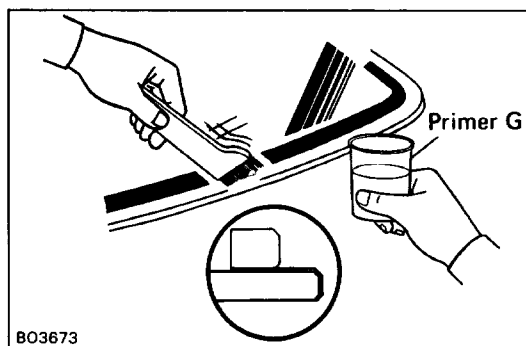
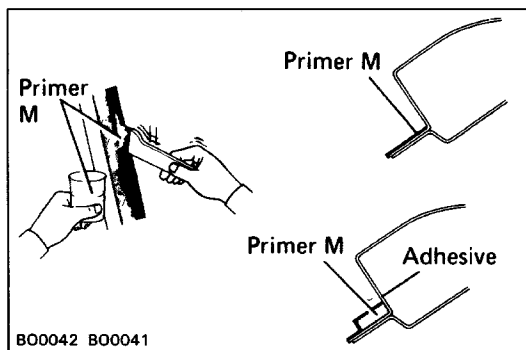

### 4. COAT CONTACT SURFACE OF GLASS WITH PRIMER "G"

(a) Using a brush or sponge, coat the edge of the glass and the contact surface with Primer G.

(b) Before the Primer dries, wipe it off with a clean cloth to avoid too thick a coat.

**NOTICE:** Be sure that installation of the glass is finished within 70 minutes.

### 5. MIX ADHESIVE COATING

**NOTICE:**

- Be sure that installation of the glass is finished within usable time. (See step 2 on page [BO-17](#))
  - The mixture should be made in 5 minutes or less.
- (a) Thoroughly clean the glass plate and putty spatula with cleaner.
- (b) Thoroughly mix 500 g (17.64 oz.) of the main agent and 75 g (2.65 oz.) of the hardening agent on a glass plate or like object with a putty spatula.

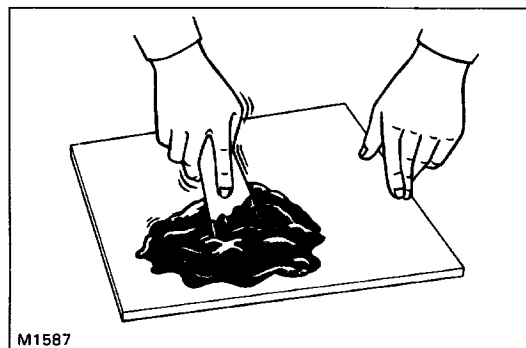

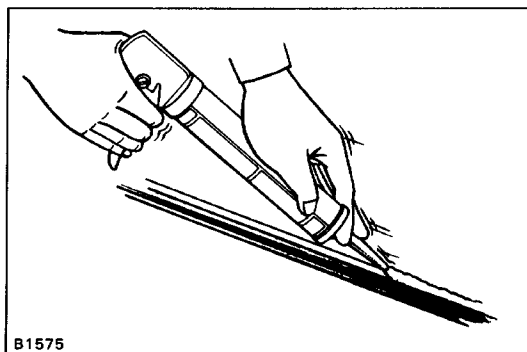

B1575

## 6. APPLY ADHESIVE

- Cut off the tip of the cartridge nozzle to make a hole 5 mm (0.20 in.) in diameter. Fill the cartridge with adhesive.
- Load the cartridge into the sealer gun.
- Coat the glass with adhesive on all contact surfaces along the ridge.

### Adhesive height:

**If adhesive remains on the body**

**3.5 – 5.0 mm (0.138 – 0.197 in.)**

**If no adhesive remains on the body**

**8 – 10 mm (0.31 – 0.39 in.)**

## 7. INSTALL GLASS

- Position the glass so that the reference marks are lined up, and press in gently along the rim.
- Using a spatula, apply adhesive on the glass rim.
- Use a spatula to remove any excess or protruding adhesive.
- Fasten glass securely until the adhesive sets.

## 8. INSPECT FOR LEAKS AND REPAIR

- Perform a leak test after the hardening time has elapsed.
- Seal any leaks with auto glass sealer.  
Part No. 08833-00030 or equivalent

## 9. INSTALL CLIPS AND WINDSHIELD MOULDING

(See page [BO-13](#))

## 10. INSTALL FOLLOWING PARTS:

(See page [BO-18](#))

- Inner rear view mirror
- Sun visors and holders
- Front pillar garnishes
- Cowl louver
- Wiper arms

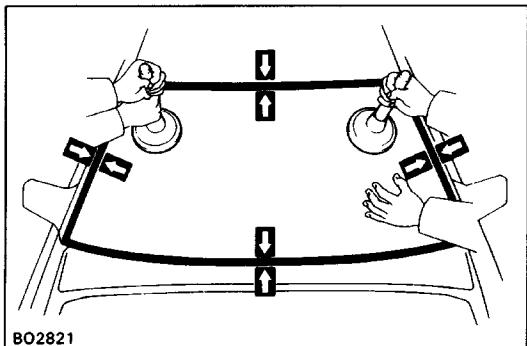

B02821

# BACK WINDOW COMPONENTS

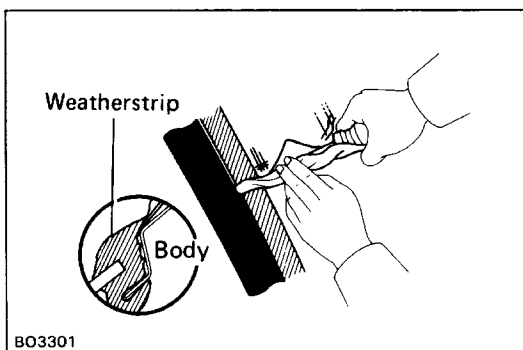
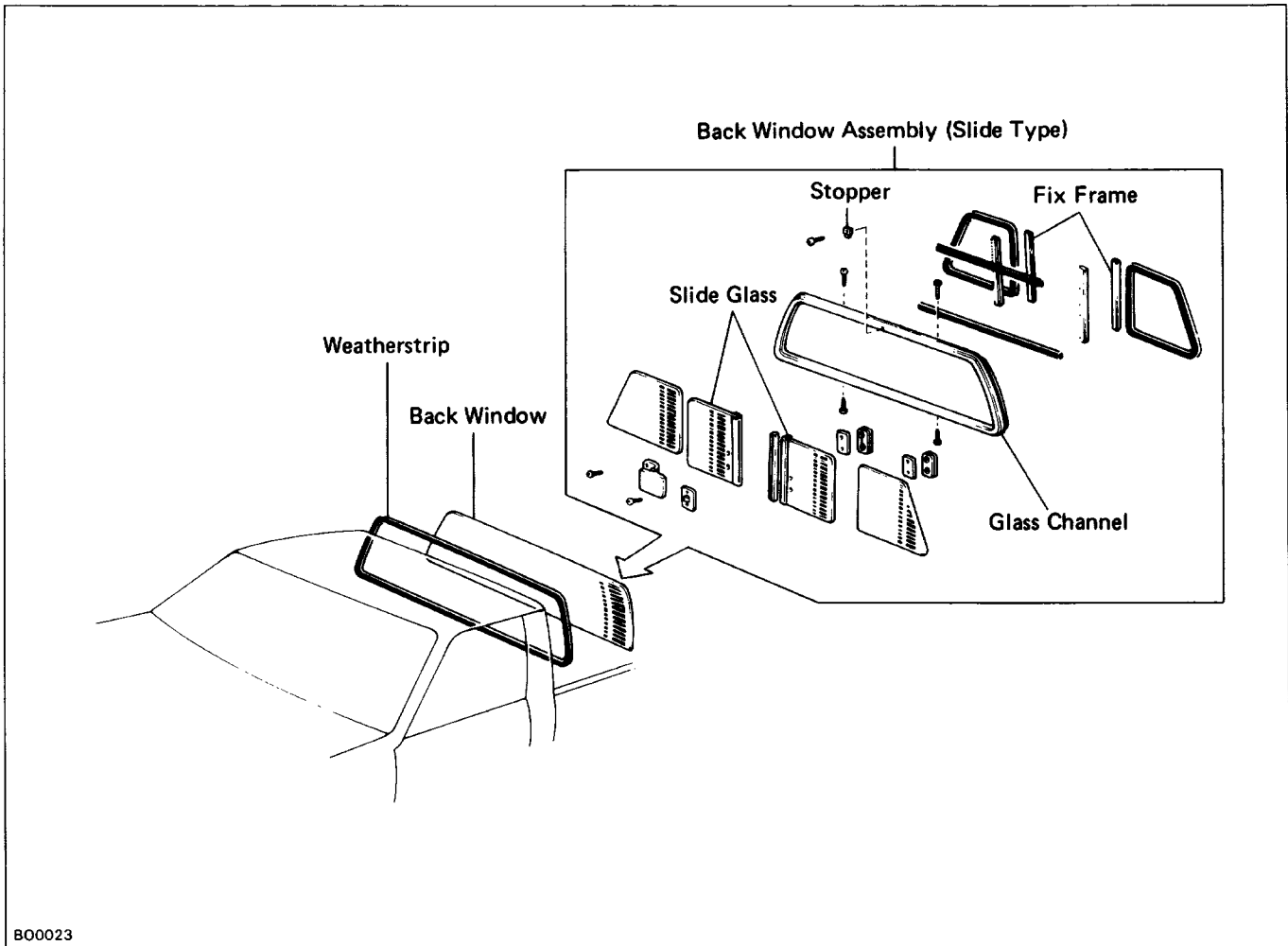

## REMOVAL OF BACK WINDOW REMOVE BACK WINDOW

(a) Using a screwdriver, loosen the weatherstrip from the body.

**NOTICE:** Be careful not to damage the body paint.

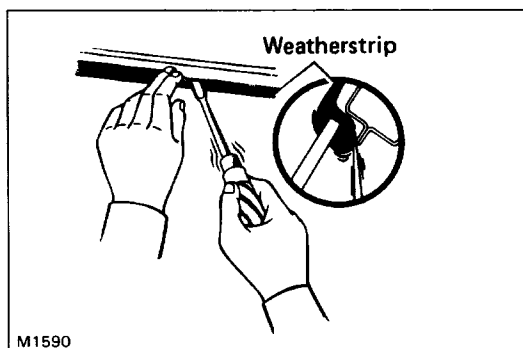

(b) Pry the lip of the weatherstrip outward from the interior part of the body flange.

(c) Pull the glass outwards, and remove it with the weatherstrip.

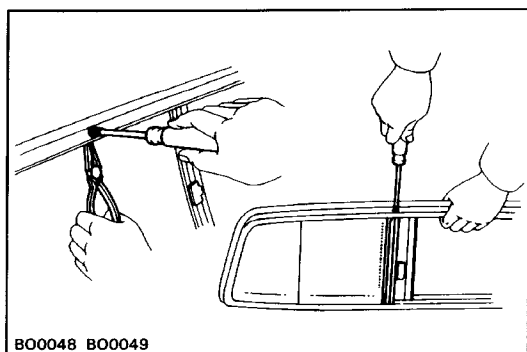

## DISASSEMBLY OF BACK WINDOW ASSEMBLY (Slide Glass type)

### 1. REMOVE FOLLOWING PARTS:

- Back window slide glass stoppers
- Four screws holding two fix frames

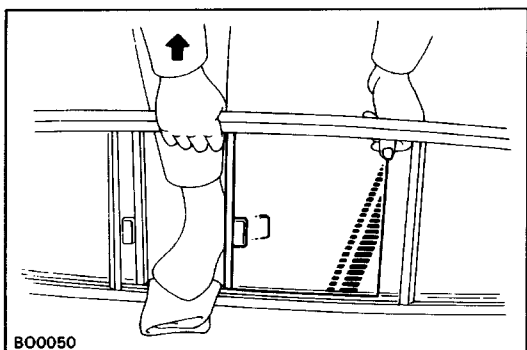

### 2. REMOVE SLIDE GLASS

Pull apart the channels and remove two slide glass panes at the center area of the glass channel.

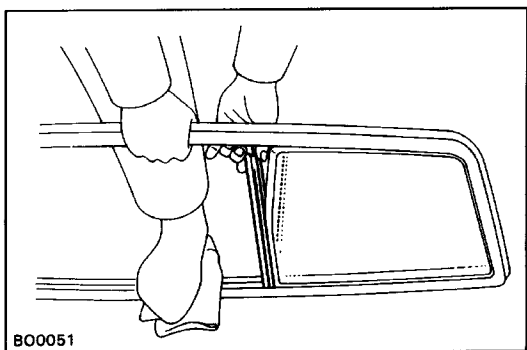

### 3. REMOVE NON-SLIDE GLASS

(a) Pull apart the channels and remove two fix frames as shown.

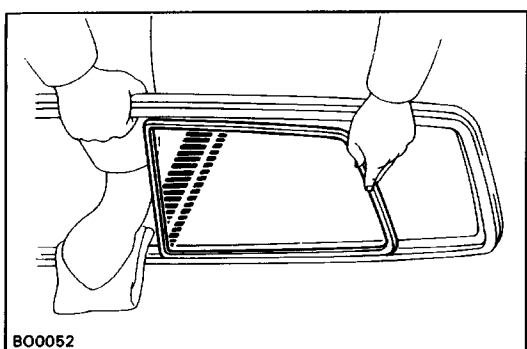

(b) Pull apart the channels and remove two non-slide glass panes as shown.

## ASSEMBLY OF BACK WINDOW ASSEMBLY

### 1. INSTALL NON-SLIDE GLASS

- Apply soapy water to the contact surface of the weatherstrip and glass channel flange.
- Install two non-slide glass panes.
- Install two fix frames.

### 2. INSTALL SLIDE GLASS

Install two slide glass panes at the center area of the glass channel.

### 3. INSTALL FOLLOWING PARTS:

- Four screws holding two fix frames
- Back window slide glass channel stoppers

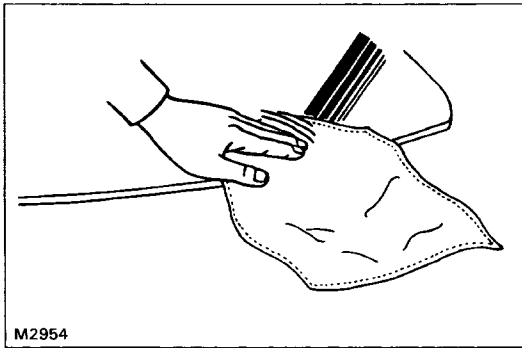

## INSTALLATION OF BACK WINDOW

### 1. CLEAN BODY AND GLASS

Using cleaner, wipe off the contact surface of the body and the glass.

### 2. CLEAN WEATHERSTRIP

Using cleaner, clean the weatherstrip surface.

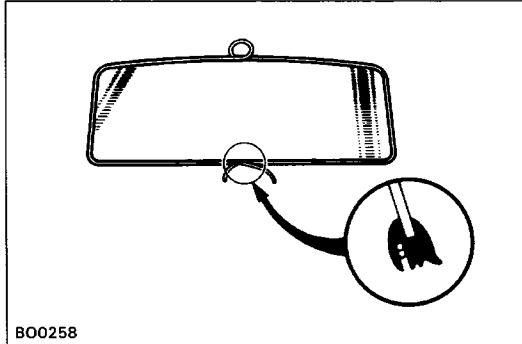

### 3. INSTALL WEATHERSTRIP ON BACK WINDOW

(a) Attach the weatherstrip to the back window.

**NOTICE:** If the weatherstrip has become hard, it may develop water leaks. Use a new one if possible.

(b) Apply a working cord along the weatherstrip groove as shown.

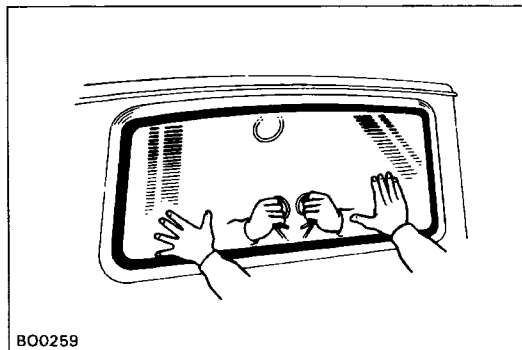

### 4. INSTALL BACK WINDOW

**HINT:** Begin installation in the middle of the lower part of the glass.

(a) Hold the back window in position on the body.

(b) Install the back window by pulling the cord from the interior, while pushing the outside of the glass with your open hand.

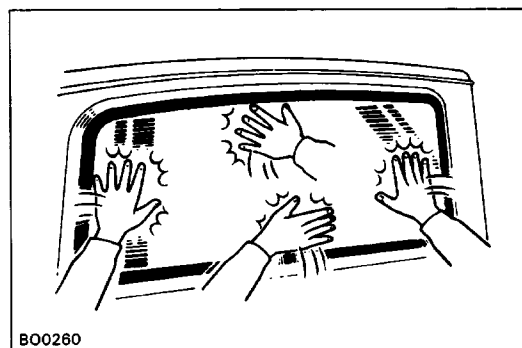

(c) To snug the back window in place, tap from the outside with your open hand.

### 5. INSPECT FOR LEAKS AND REPAIR

(a) Perform a leak test.

(b) Seal any leak with auto glass sealer.

Part No. 08830-00030 or equivalent

# QUARTER WINDOW (Xtra Cab) COMPONENTS

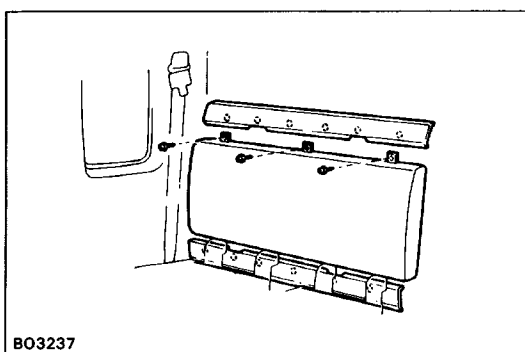
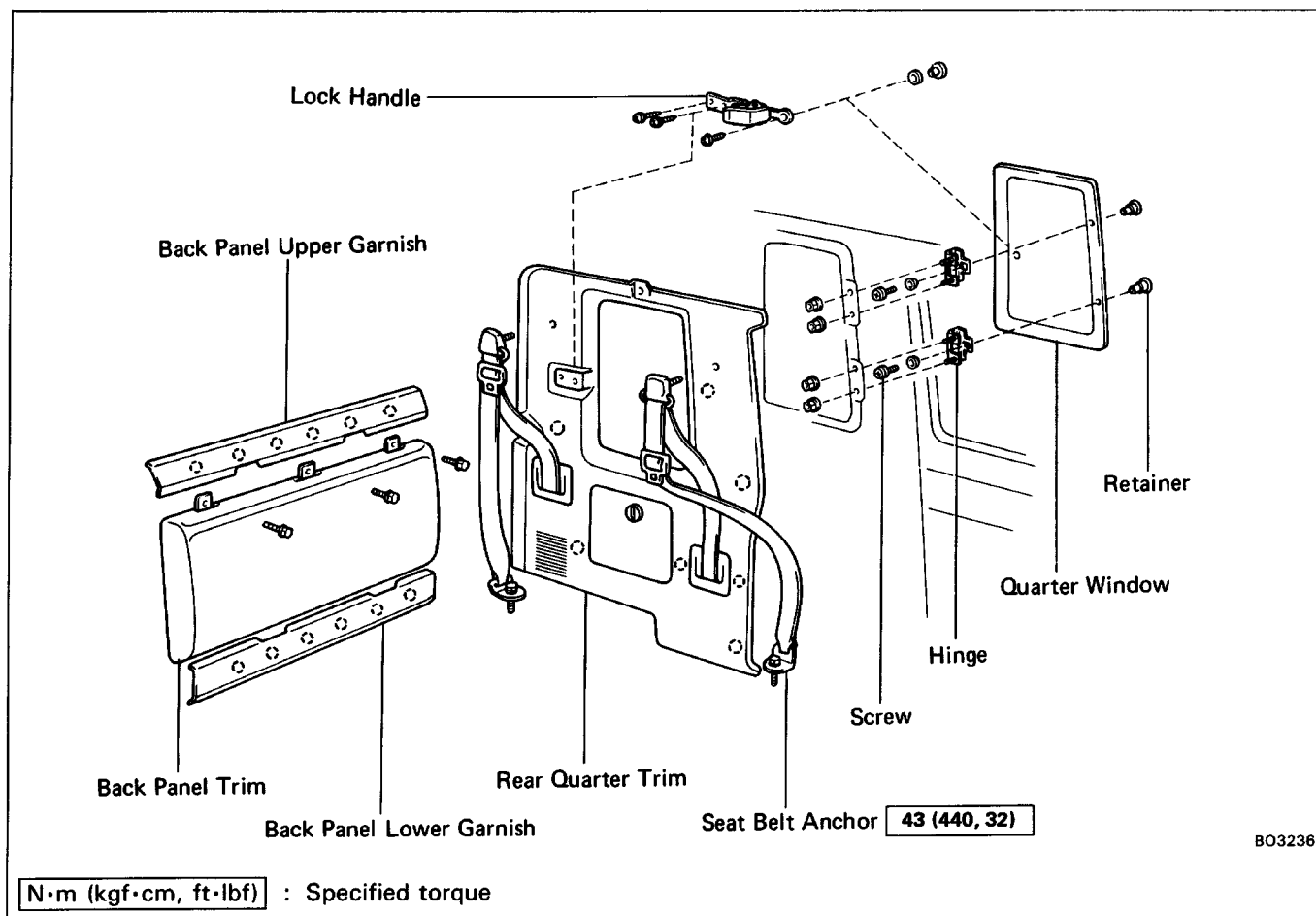

## REMOVAL OF QUARTER WINDOW

### 1. REMOVE BACK PANEL GARNISHES AND BACK PANEL TRIM

- Remove the back panel lower garnish.
- Remove the back panel upper garnish.
- Remove three bolts and the back panel trim.

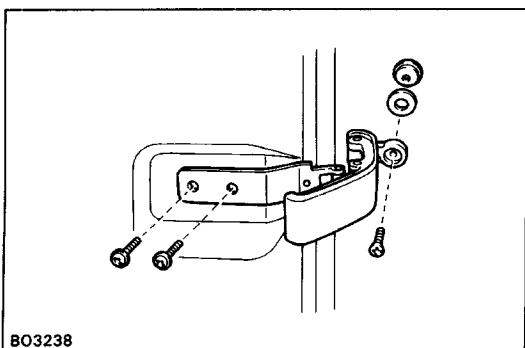

### 2. REMOVE LOCK HANDLE

Remove three screws and the lock handle.



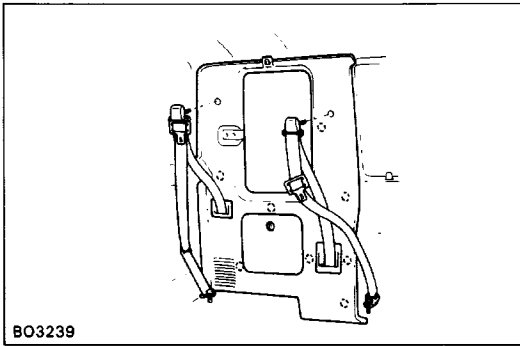

### 3. REMOVE REAR QUARTER TRIM

(a) Remove four bolts, the seat belt anchors and the belt guide.

(See pages [BO-46](#) and [47](#))

(b) Remove the screw and the hook.  
c) Remove the rear quarter trim.

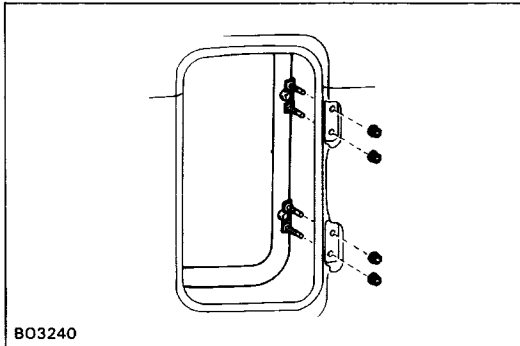

### 4. REMOVE QUARTER WINDOW

Remove four nuts and the quarter window.

### 5. REMOVE HINGES FROM WINDOW GLASS

Remove two screws and the hinges.

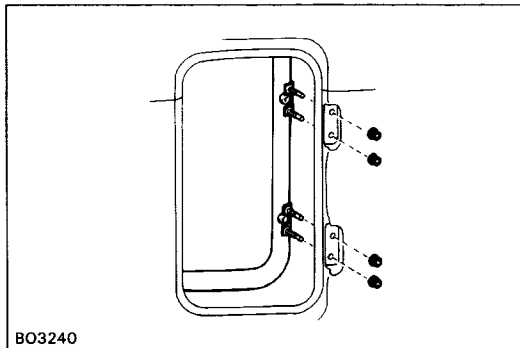

## INSTALLATION OF QUARTER WINDOW

### 1. INSTALL HINGES TO WINDOW GLASS

Install the two hinges with the screws.

### 2. INSTALL QUARTER WINDOW

Install the quarter window with four nuts.

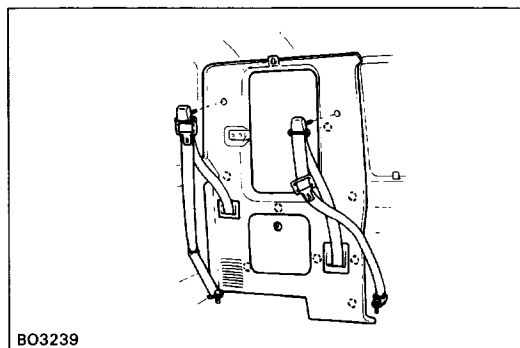

### 3. INSTALL REAR QUARTER TRIM

(a) Install the rear quarter trim.

(b) Install the hook with the screw.

(c) Install the seat belt anchor with four bolts.

(See pages [BO-46](#) and [47](#))

**Torque: 43 N-m (440 kgf-cm, 32 ft-lbf)**

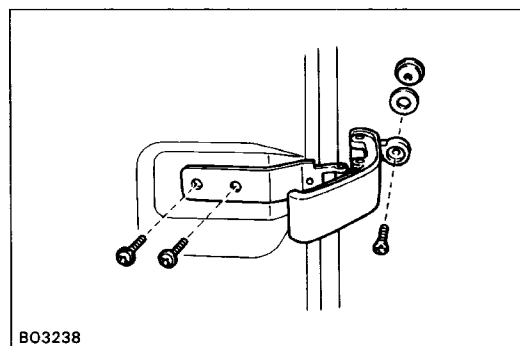

### 4. INSTALL LOCK HANDLE

Install the lock handle with three screws.

### 5. INSTALL BACK PANEL TRIM AND BACK PANEL GARNISHES

(a) Install the back panel trim with three bolts.

(b) Install the back panel upper garnish by tapping.

(c) Install the back panel lower garnish.

# MOON ROOF COMPONENTS

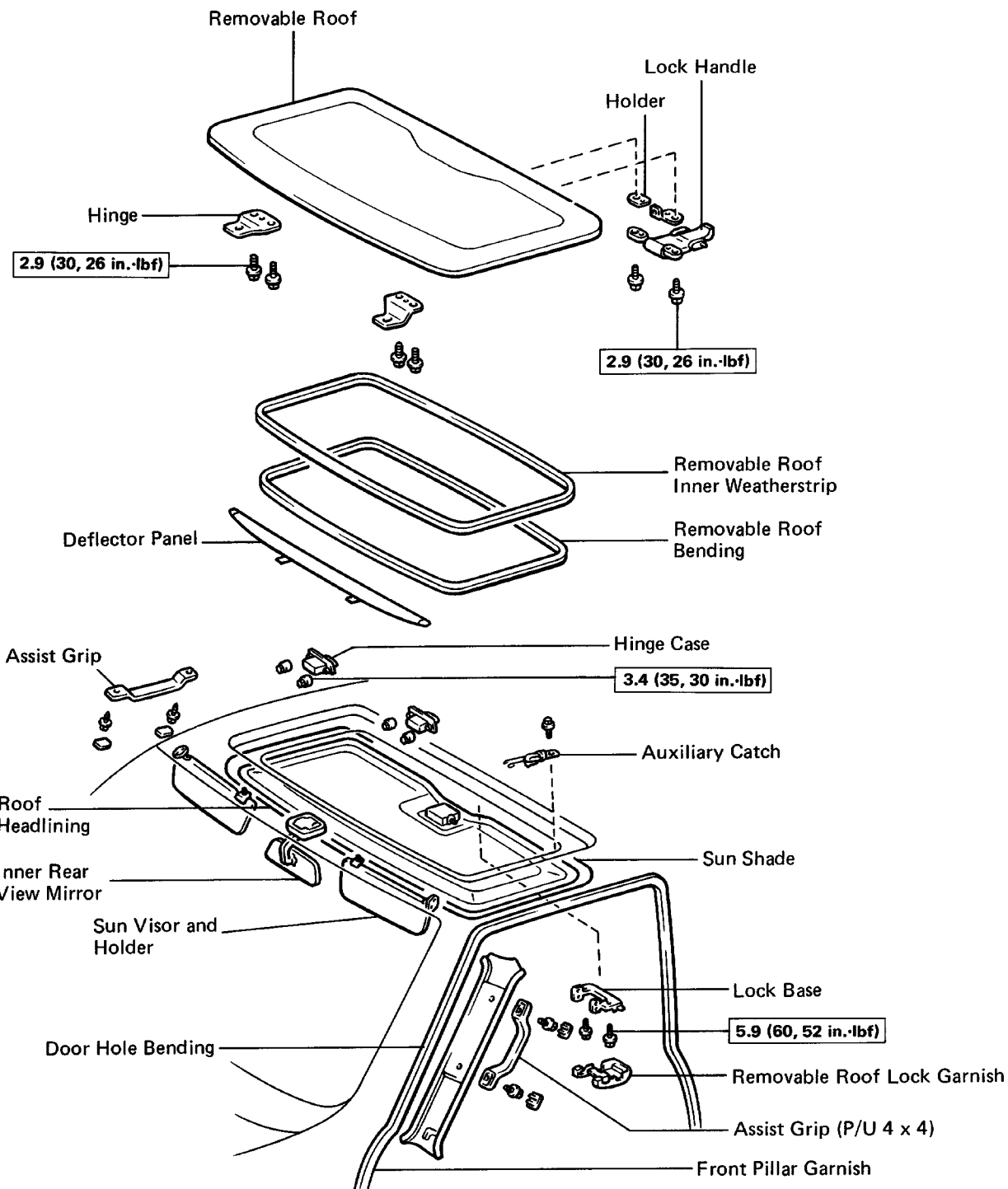

N02777

**N·m (kgf·cm, ft·lbf) : Specified torque**

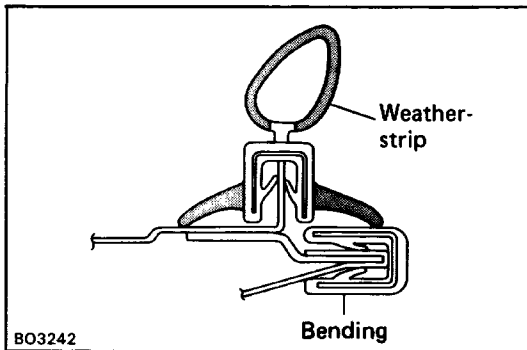

## REMOVAL OF MOON ROOF

(See page [BO-31](#))

1. REMOVE REMOVABLE ROOF WITH SUN SHADE
2. REMOVE REMOVABLE ROOF INNER WEATHERSTRIP
3. REMOVE REMOVABLE ROOF BENDING

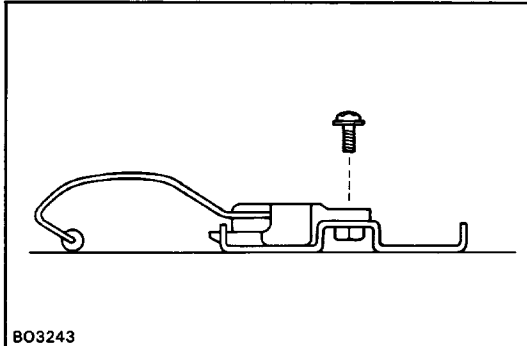

4. REMOVE REMOVABLE ROOF AUXILIARY CATCH

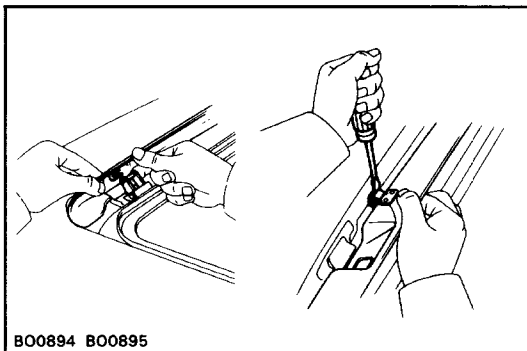

### 5. REMOVE WIND DEFLECTOR PANEL

- (a) Remove two outside deflector clips on the left and right sides.
- (b) Remove two inside deflector clips on the left and right sides, while prying it with a screwdriver.

HINT: Tape the screwdriver tip before use.

### 6. REMOVE REMOVABLE ROOF LOCK GARNISH

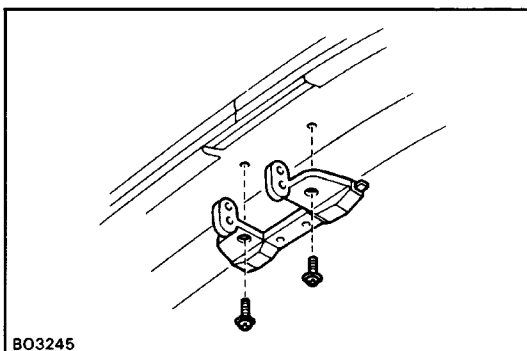

### 7. REMOVE REMOVABLE ROOF LOCK BASE

Remove two screws and the lock base.

### 8. REMOVE FOLLOWING PARTS:

(See page [BO-31](#))

- Inner rear view mirror
- Sun visors and holders
- Assist grip
- Front pillar garnishes
- Door hole bendings

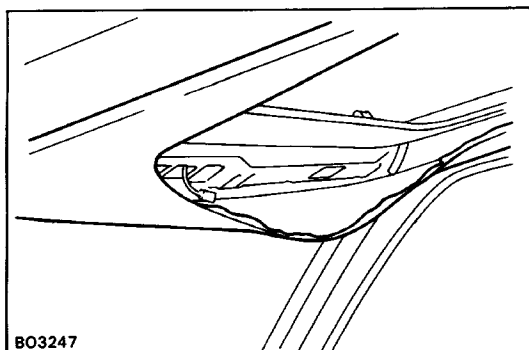

### 9. REMOVE ROOF HEADLINING

- (a) Remove the roof headlining as shown, and leave it hanging.
- (b) Remove any double-stick tape remaining on the body.

**NOTICE:** Do not damage the roof headlining.

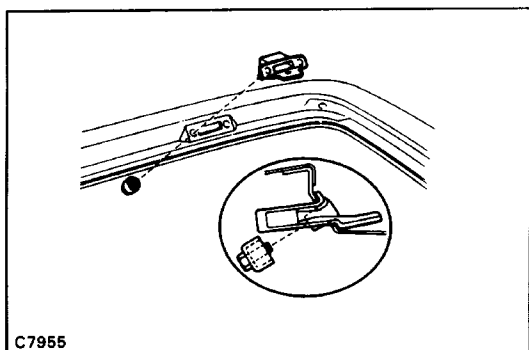

### 10. REMOVE REMOVABLE ROOF HINGE CASE

Remove two bolts and the hinge case.

## INSTALLATION OF MOON ROOF

(See page [BO-31](#))

### 1. INSTALL REMOVABLE ROOF HINGE CASE

Install the hinge case with the bolts.

**Torque:** 3.4 N-m (35 kgf-cm, 30 in.-lbf)

**HINT:**

- Make sure the seal is properly torqued.
- If any part of the seal is damaged, replace the seal and case.

### 2. INSTALL REMOVABLE ROOF HEADLINING

- (a) Apply double-stick tape to the edge of the roof panel.
- (b) Install the roof headlining to the double-stick tape on the body.

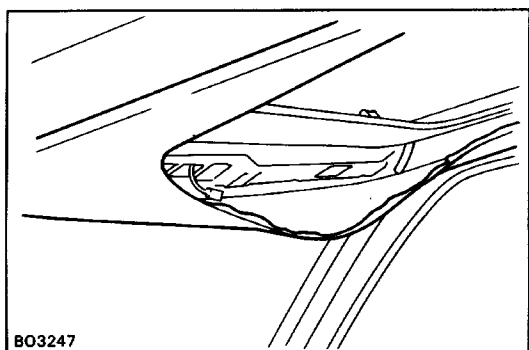

### 3. INSTALL FOLLOWING PARTS:

(See page [BO-31](#))

- Door hole bendings
- Front pillar garnishes
- Assist grip
- Sun visors and holders
- Inner rear view mirror

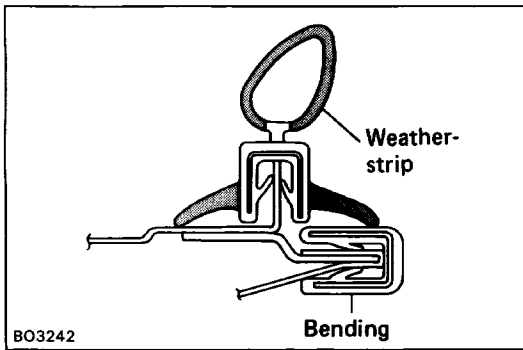
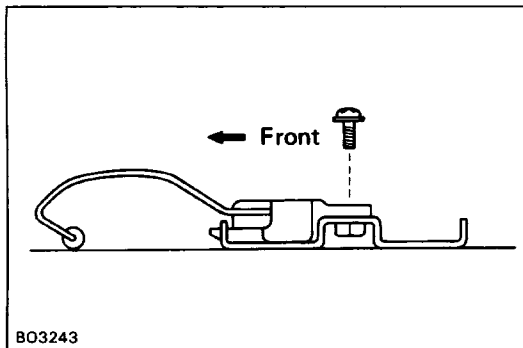
**4. INSTALL REMOVABLE ROOF BENDING****5. INSTALL REMOVABLE ROOF INNER WEATHERSTRIP****6. INSTALL REMOVABLE ROOF AUXILIARY CATCH**

Install the auxiliary catch with the bolt.

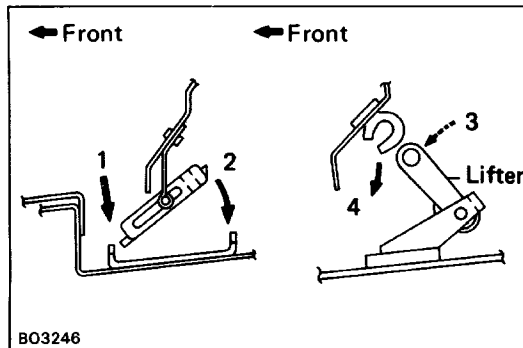
**7. INSTALL WIND DEFLECTOR PANEL**

Install the deflector clips as shown in the illustration.

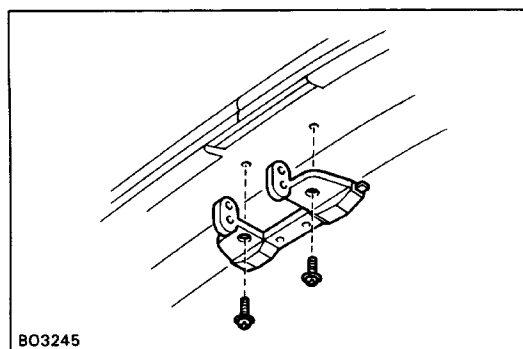
**8. INSTALL REMOVABLE ROOF LOCK BASE**

Install the lock base, and lightly tighten the bolts.

**9. INSTALL REMOVABLE ROOF WITH SUN SHADE****10. TORQUE REMOVABLE ROOF LOCK BASE BOLTS**

Torque: 5.9 N-m (60 kgf-cm, 52 in.-lbf)

**11. INSTALL REMOVABLE ROOF LOCK GARNISH**

## DISASSEMBLY OF REMOVABLE ROOF

(See page [BO-31](#) )

1. REMOVE HANDLE WITH HOLDER
2. REMOVE LEFT/RIGHT HINGE

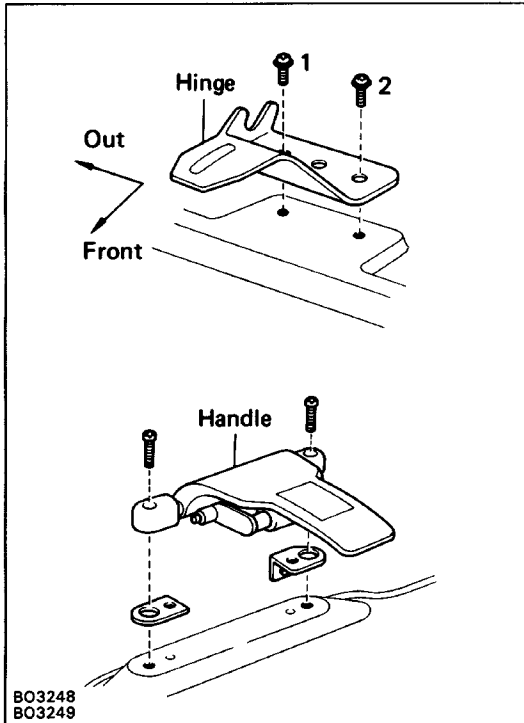

## ASSEMBLY OF REMOVABLE ROOF

### 1. INSTALL LEFT/RIGHT HINGE





- (a) Install the hinge with two screws.
- (b) Torque the outside screw.  
Torque: 2.9 N-m (30 kgf-cm, 26 in.-lbf)
- (c) Torque the inside screw.  
Torque: 2.9 N-m (30 kgf-cm, 26 in.-lbf)

### 2. INSTALL HOLDER AND HANDLE

- (a) Install the holder and handle with two bolts.
- (b) Torque the bolts.  
Torque: 2.9 N-m (30 kgf-cm, 26 in.-lbf)

# INSTRUMENT PANEL COMPONENTS





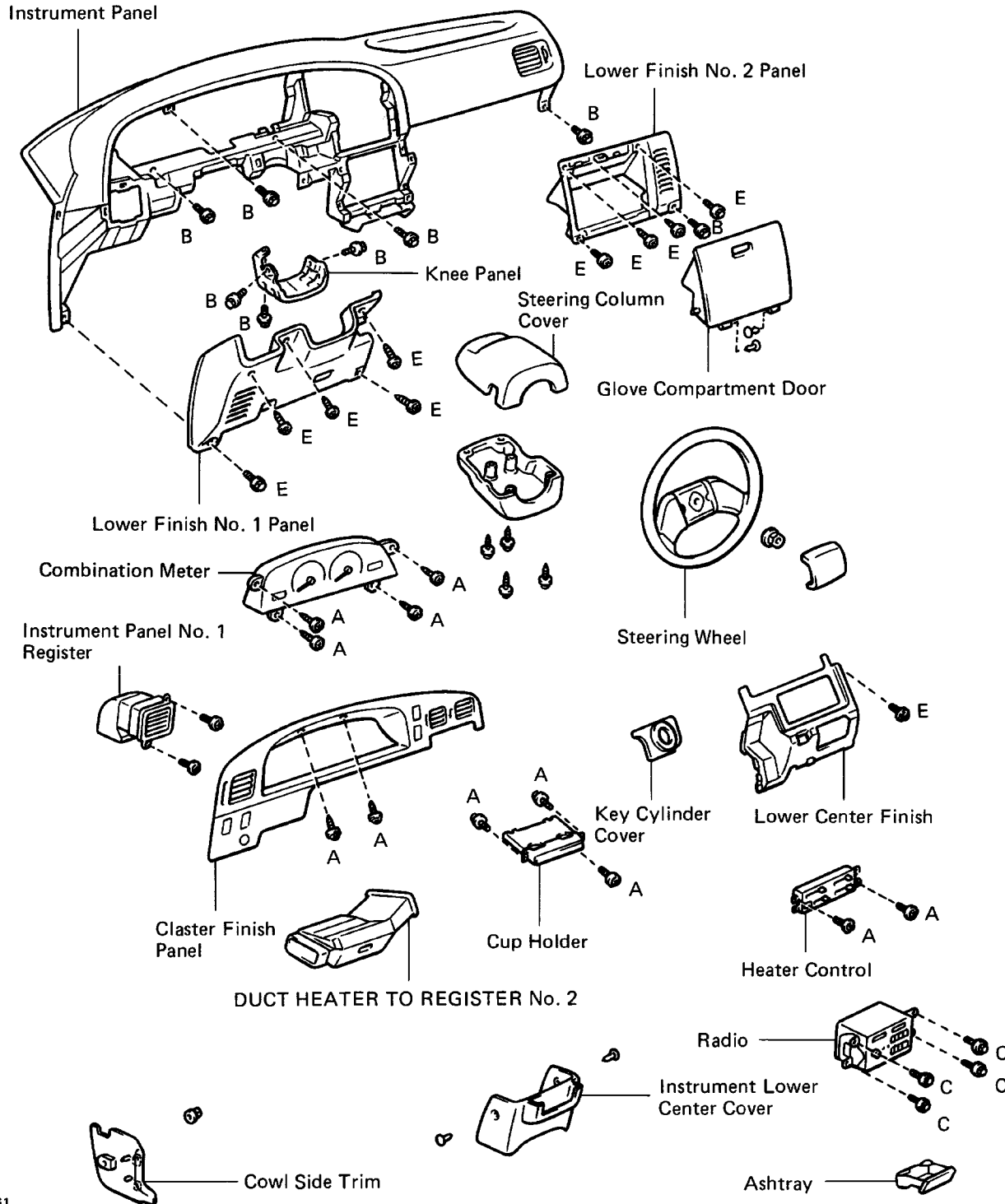

Models Ex. 4-Speed M/T

Code	Shape	Size	Code	Shape	Size	Code	Shape	Size
A		$\phi = 5$ (0.20) L = 14 (0.55)	B		$\phi = 6$ (0.24) L = 22 (0.87)	C		$\phi = 5$ (0.20) L = 18 (0.71)
D		$\phi = 5$ (0.20) L = 16 (0.63)	E		$\phi = 5$ (0.20) L = 16 (0.63)			



# COMPONENTS (Cont'd)

## 4-Speed M/T Models

Code	Shape	Size	Code	Shape	Size	Code	Shape	Size
A		$\phi = 5$ (0.20) L = 14 (0.55)	B		$\phi = 6$ (0.24) L = 22 (0.87)	C		$\phi = 5$ (0.20) L = 18 (0.71)
D		$\phi = 5$ (0.20) L = 16 (0.63)	E		$\phi = 5$ (0.20) L = 16 (0.63)	F		$\phi = 5$ (0.20) L = 14 (0.55)

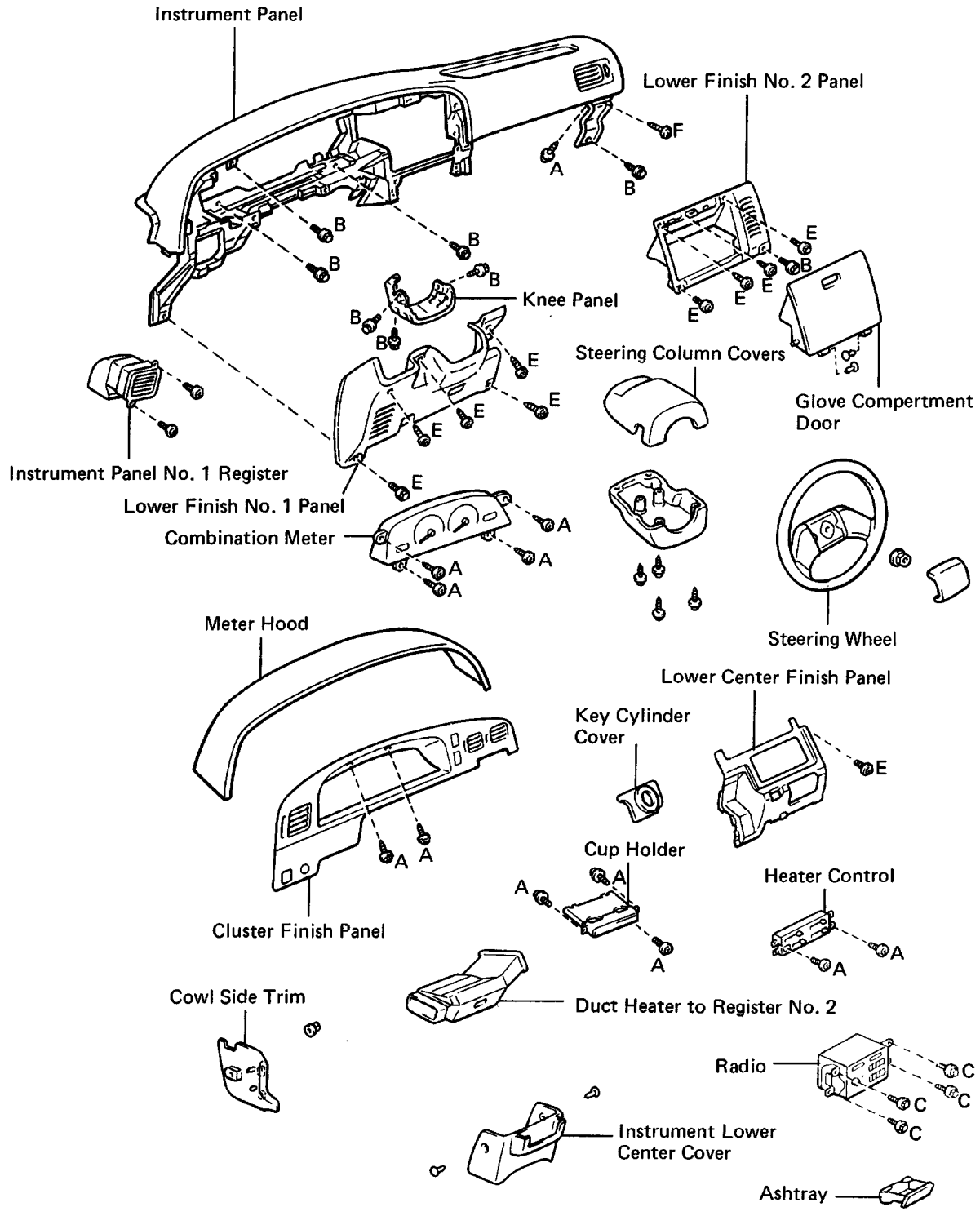



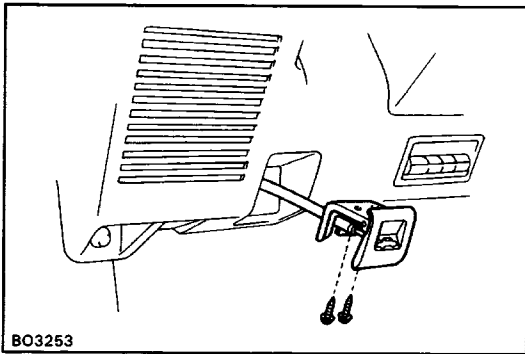

BO3253

## REMOVAL OF INSTRUMENT PANEL

(See pages [BO-36](#) and [37](#))

**1. DISCONNECT BATTERY CABLE FROM NEGATIVE TERMINAL**

**2. REMOVE STEERING WHEEL**

(See page [SR-4](#))

**3. REMOVE STEERING COLUMN COVERS**

(See page [SR-4](#))

**4. REMOVE ENGINE HOOD RELEASE LEVER**

Remove two screws and the engine hood release lever.

**5. REMOVE COWL SIDE TRIM**

Remove the nut and the cowl side trim.

**6. REMOVE INSTRUMENT LOWER CENTER COVER**

Remove two clips and the cover.

**7. REMOVE KEY CYLINDER COVER**

Pry out the key cylinder cover.

**8. REMOVE LOWER FINISH NO.1 PANEL**

(a) Remove four screws, one bolt and the panel.

(b) Disconnect the connector.

**9. REMOVE DUCT HEATER TO REGISTER NO.2**

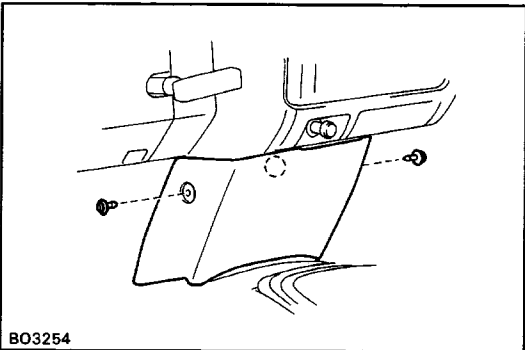

BO3254

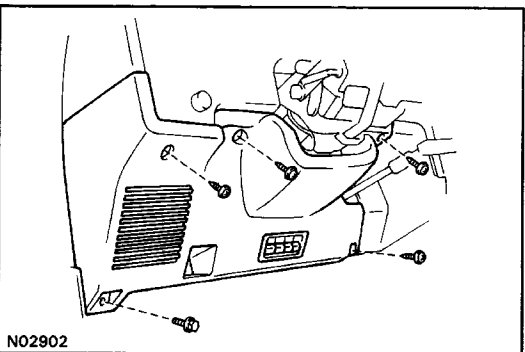

NO2902

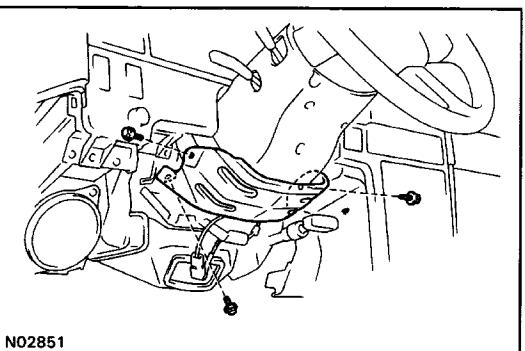

NO2851

**10. REMOVE KNEEPANEL**

Remove the three bolts and knee panel.

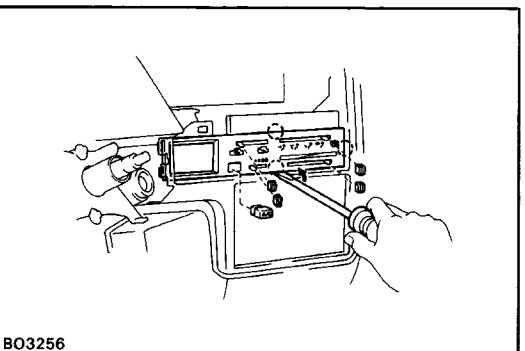

BO3256

**11. REMOVE HEATER CONTROL PLATE**

(a) Pull off the heater control knobs.

(b) (w/ A/C)

Pry off the A/C switch.

(c) Using a screwdriver, pry out the heater control plate as shown in the illustration, and remove it.

HINT: Tape the screwdriver tip before use.

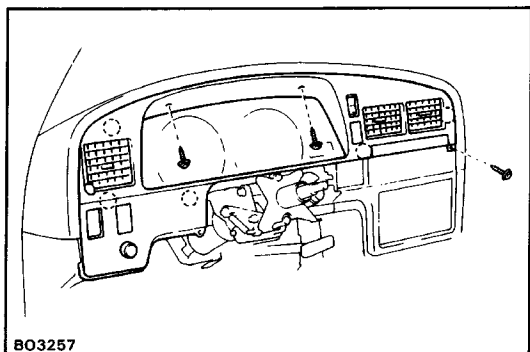

**12-1.(Models Ex. 4-Speed M/T)  
REMOVE CLUSTER FINISH PANEL**

- (a) Remove three screws and pull out the cluster finish panel.
- (b) Disconnect the connectors.
- (c) Remove two screws and the cup holder from the cluster finish panel.

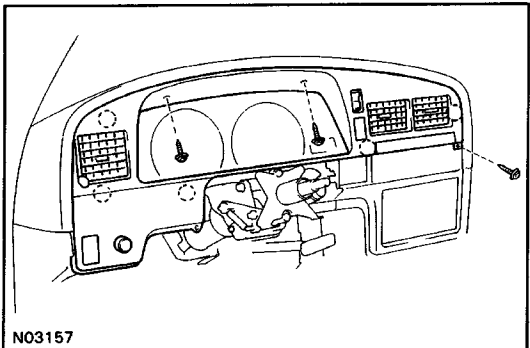

**12-2.(4-Speed M/T Models)  
REMOVE CLUSTER FINISH PANEL WITH METER HOOD**

- (a) Remove two screws and pull out the cluster finish panel with meter hood.
- (b) Disconnect the connectors.
- (c) Pull off the meter hood.
- (d) Remove two screws and the cup holder from the cluster finish panel.

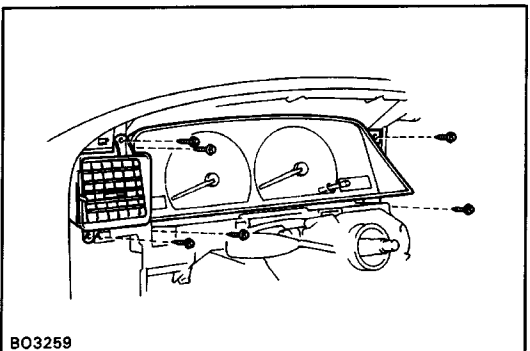

**13. REMOVE INSTRUMENT PANEL NO. 1 REGISTER**

Remove two screws and the register.

**14. REMOVE COMBINATION METER**

- (a) Remove four screws.
- (b) Disconnect the connectors.
- (c) Remove the combination meter.

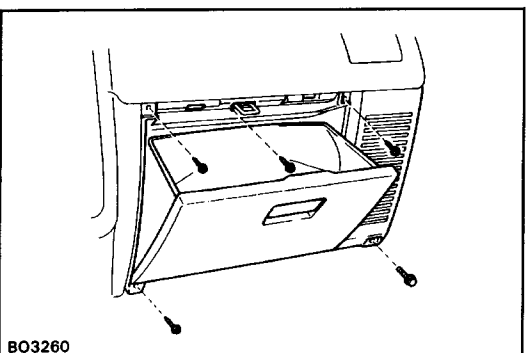

**15. REMOVE LOWER FINISH NO.2 PANEL WITH GLOVE COMPARTMENT DOOR**

- (a) Remove four screws, one bolt and the lower finish No.2 panel with glove compartment door.
- (b) Disconnect the connector.

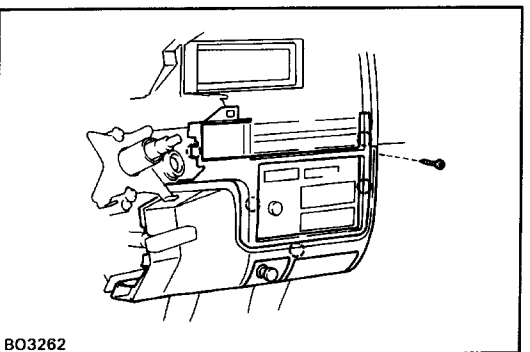

**16. REMOVE LOWER CENTER FINISH PANEL**

- (a) Remove a screw and pull out the panel.
- (b) Disconnect the connectors.

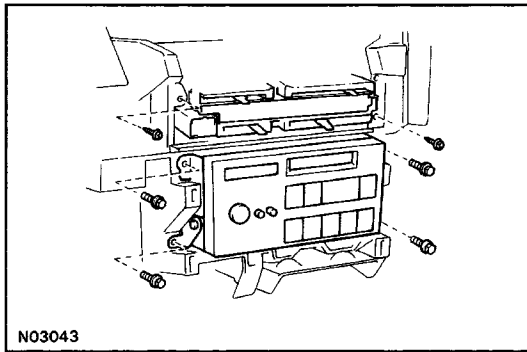
**17. REMOVE HEATER CONTROL**

Remove two screws and hang the heater control.

**18. REMOVE RADIO**

- (a) Remove four bolts
- (b) Disconnect the antenna cable and connectors.
- (c) Remove the radio with bracket.

**19. REMOVE INSTRUMENT PANEL**

- (a) Remove four bolts and the instrument panel.
- (b) Disconnect the connectors.

HINT: The instrument panel has a boss onto the clip on the body side. Therefore when removing, pull upward at an angle.

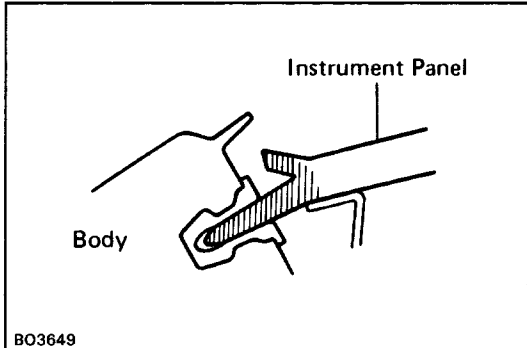
**20. REMOVE FOLLOWING PARTS FROM INSTRUMENT PANEL**

**(Models Ex. 4-Speed M/T)**

- (a) Safety pad
- (b) No. 3, No. 5 heater to register ducts
- (c) Instrument panel No.2 register
- (d) Center bracket
- (e) Cowl bracket

Models Ex. 4-speed M/T

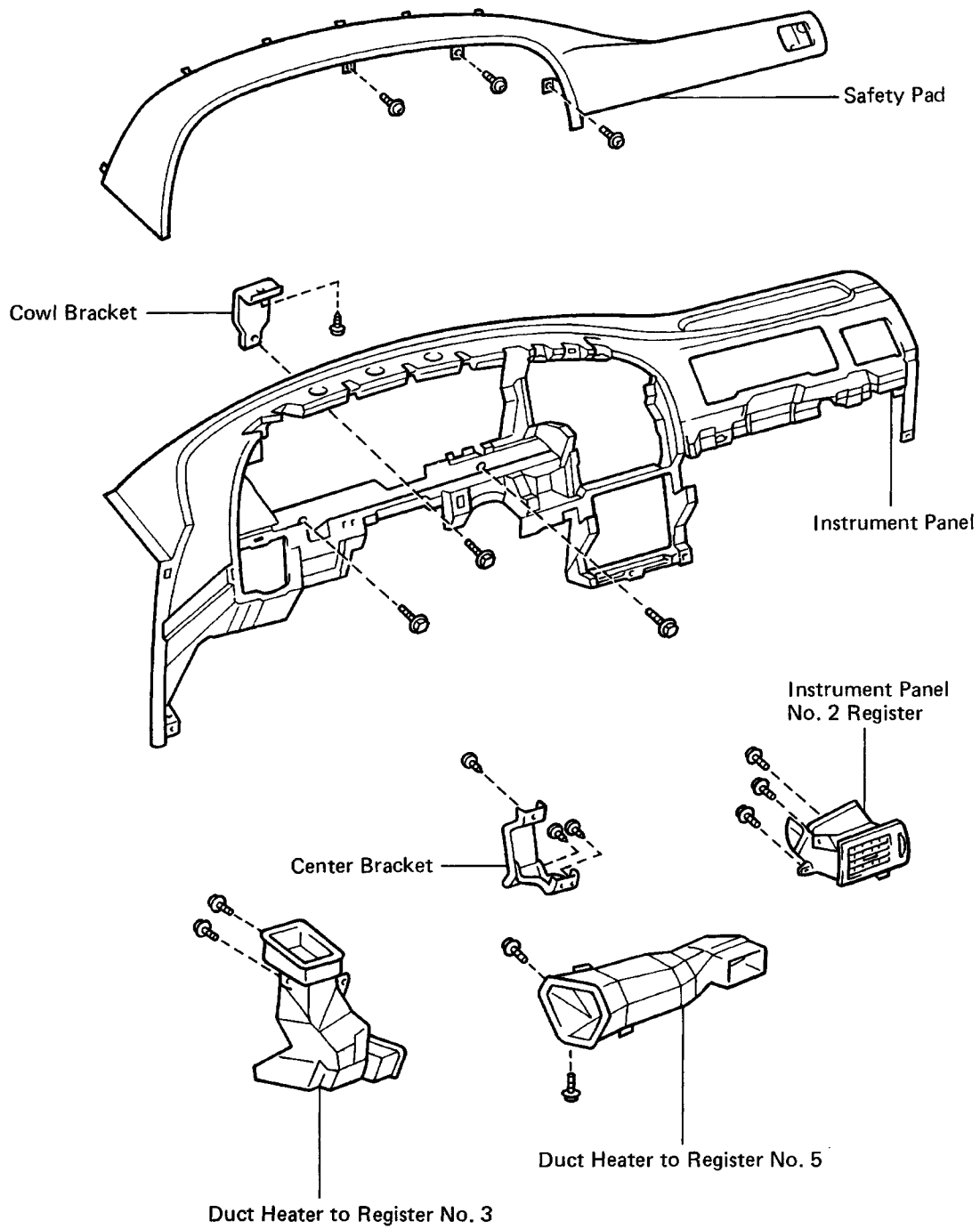

N03024

**(4-Speed M/T Models)**

- (a) No.3, No.5 heater to register duct
- (b) Instrument panel No.2 register
- (c) No.2, No.3 Instrument stay
- (d) Mounting bracket
- (e) Cowl bracket

## 4-Speed M/T Models

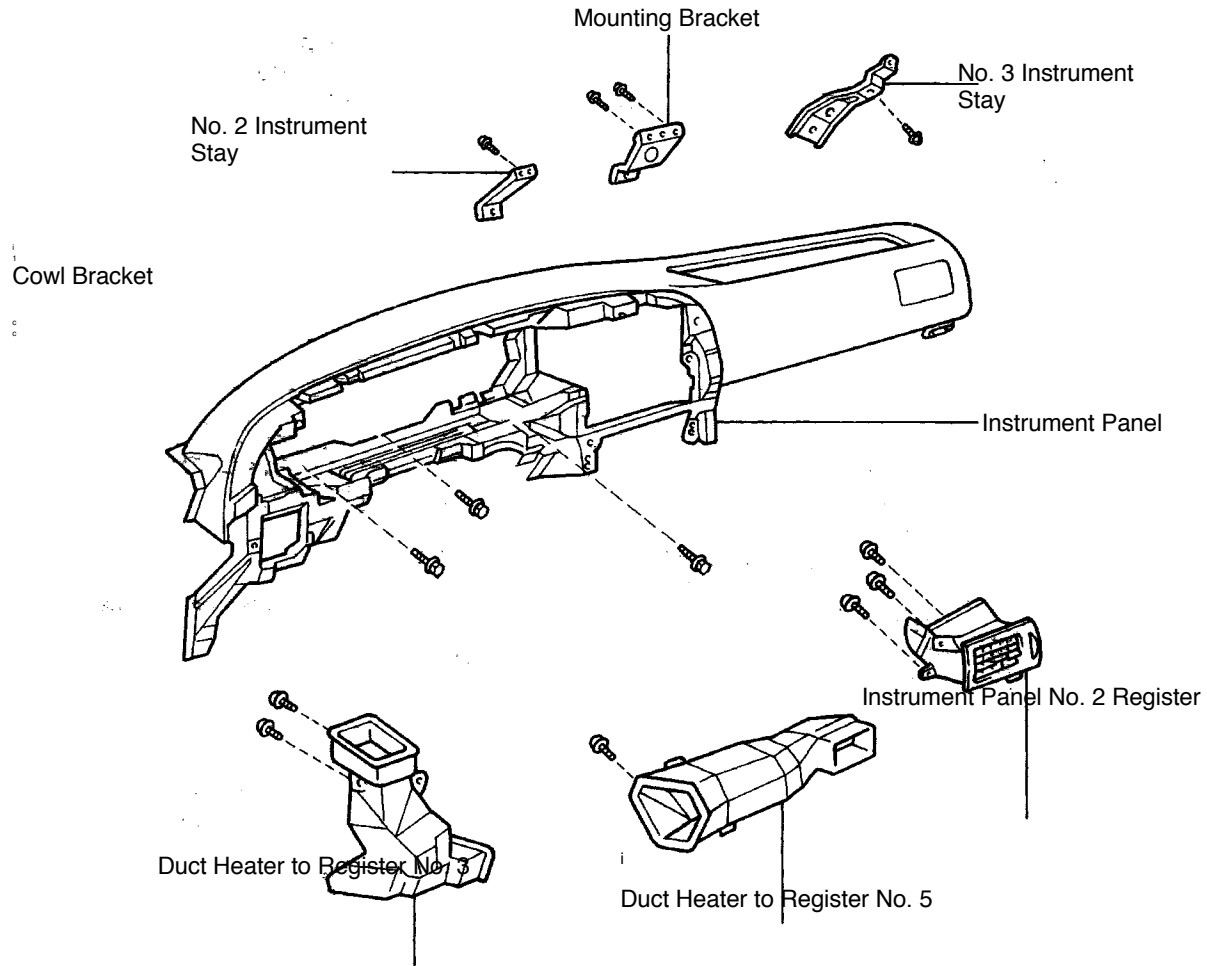

N02903

**INSTALLATION OF INSTRUMENT PANEL**(See pages [BO-36](#) and 37)**INSTALL INSTRUMENT PANEL PARTS FOLLOWING  
REMOVAL SEQUENCE IN REVERSE**

# ONE-TOUCH TAIL GATE COMPONENTS

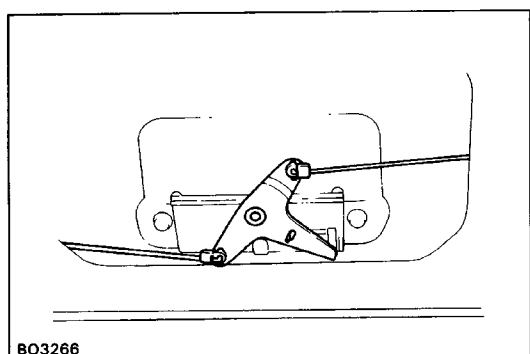
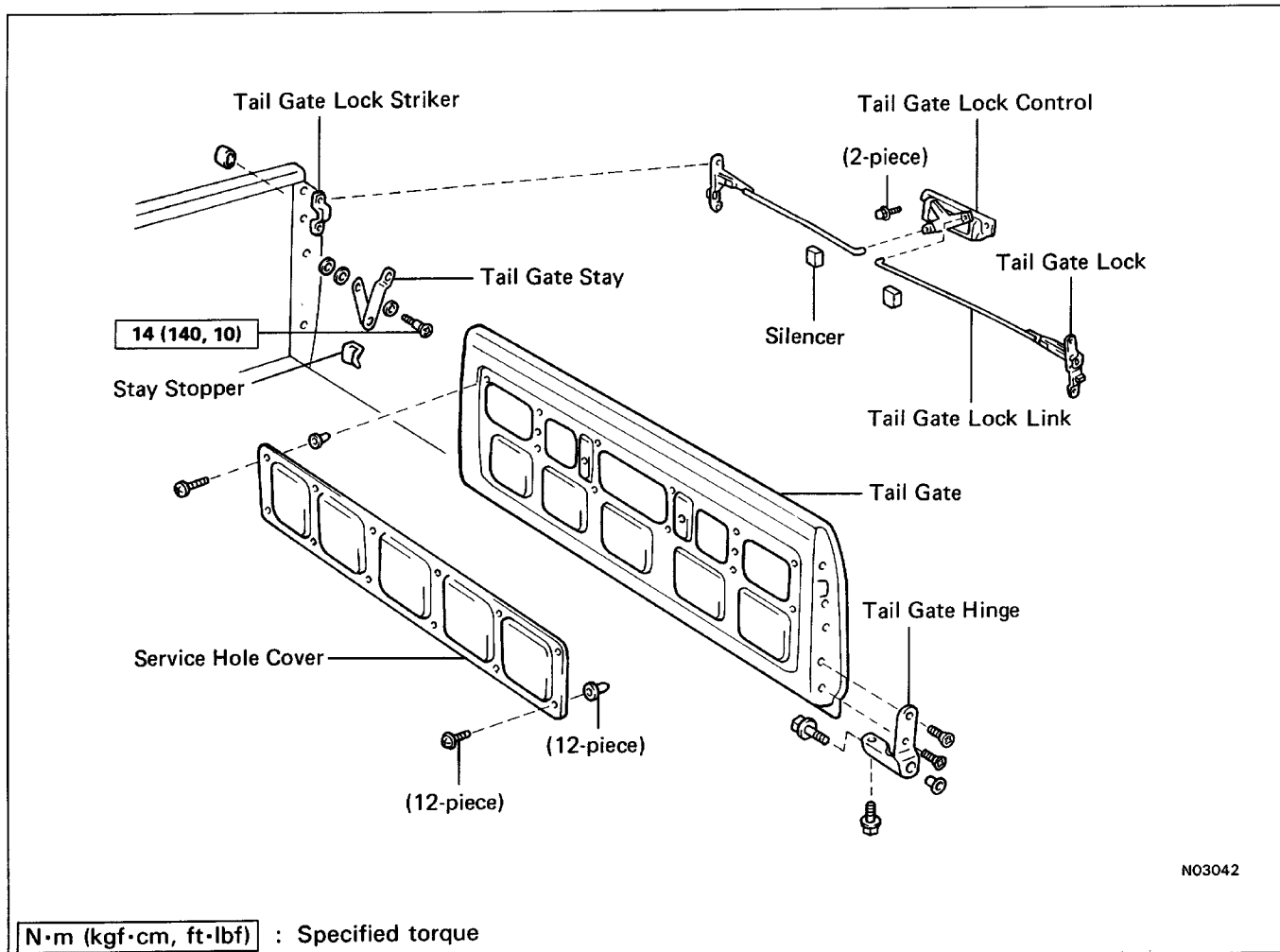

## REMOVAL OF TAIL GATE LOCK

### 1. REMOVE SERVICE HOLE COVER

Remove twelve screws and the service hole cover.

### 2. DISCONNECT TAIL GATE LOCK LINK FROM TAIL GATE LOCK CONTROL

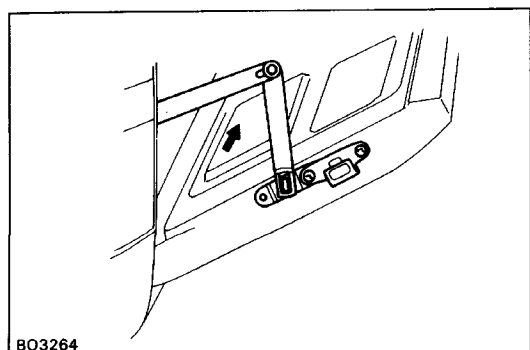

### 3. REMOVE TAIL GATE STAY

- (a) Disconnect the tail gate stay from the tail gate.
- (b) Remove the bolt and the tail gate stay from the body.

### 4. REMOVE TAIL GATE LOCK FROM TAIL GATE

Remove two screws and the tail gate lock.

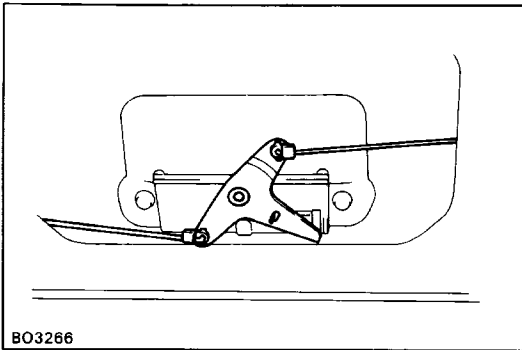

## INSTALLATION OF TAIL GATE LOCK

### 1. INSTALL TAIL GATE LOCK TO TAIL GATE

Install the tail gate lock with the two screws.

### 2. INSTALL TAIL GATE STAY

(a) Install the tail gate stay and the bolt.

**Torque: 14 N-m (140 kgf-cm, 10 ft-lbf)**

(b) Connect the tail gate stay to the tail gate.

### 3. CONNECT TAIL GATE STAY TO TAIL GATE

### 4. INSTALL SERVICE HOLE COVER

Install service hole cover with twelve screws.

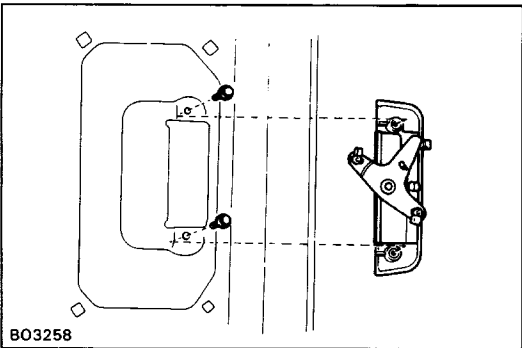
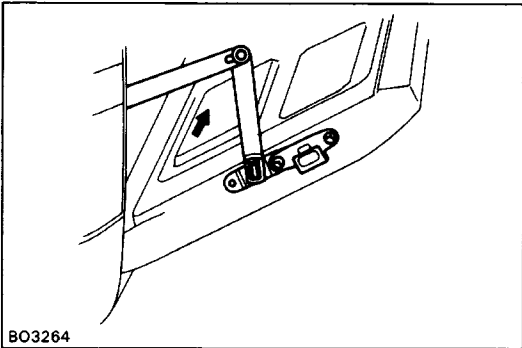

## REMOVAL OF TAIL GATE LOCK CONTROL

### 1. REMOVE SERVICE HOLE COVER

### 2. DISCONNECT TWO TAIL GATE LOCK LINKS

### 3. REMOVE TAIL GATE LOCK CONTROL

## INSTALLATION OF TAIL GATE LOCK CONTROL

INSTALL TAIL GATE LOCK CONTROL IN REVERSE ORDER OF REMOVAL

# SEAT

## Front Seat

### COMPONENTS

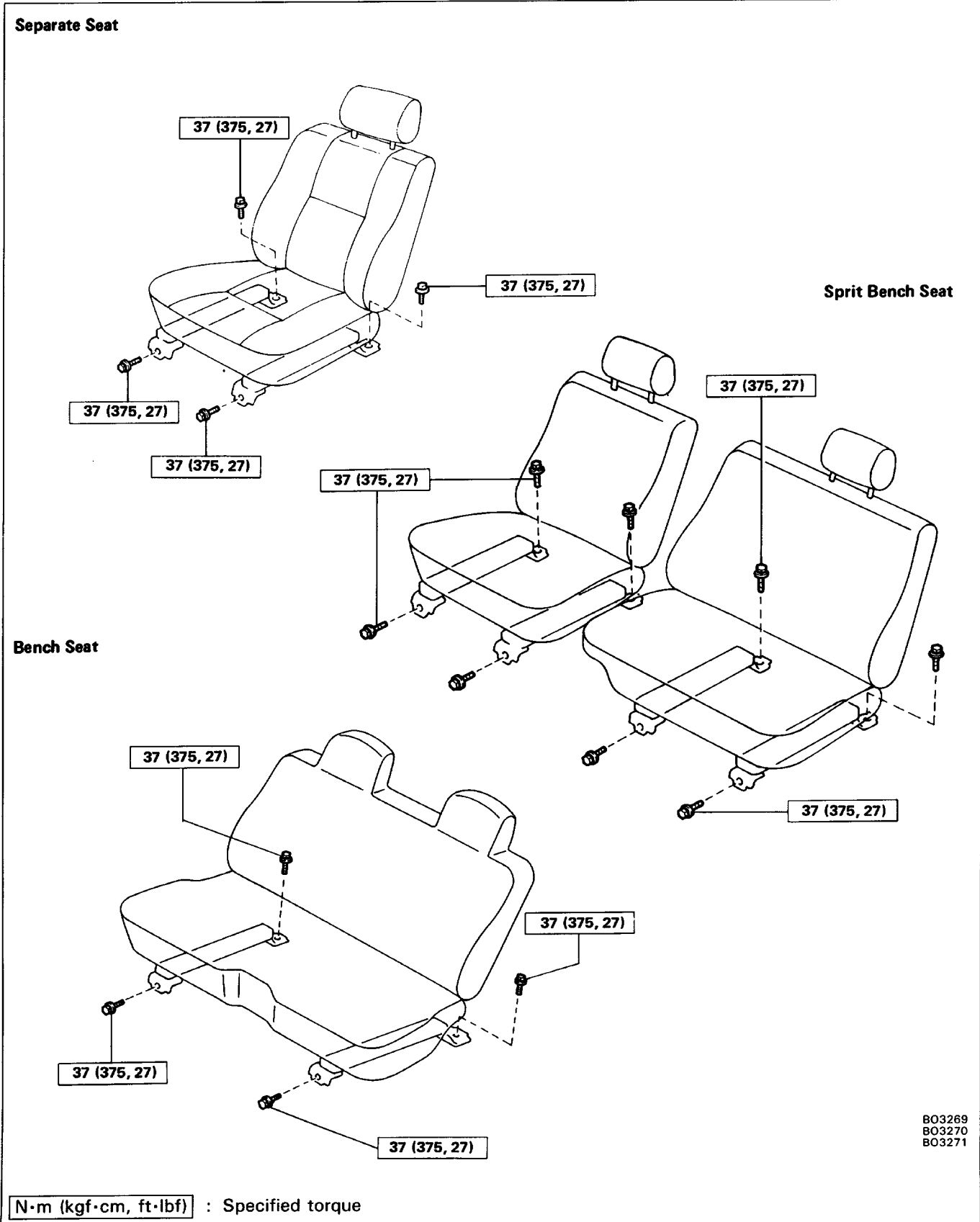

B03269  
B03270  
B03271

**N·m (kgf·cm, ft·lbf)** : Specified torque



## Rear Jump Seat COMPONENTS (Cont'd)

Xtra Cab

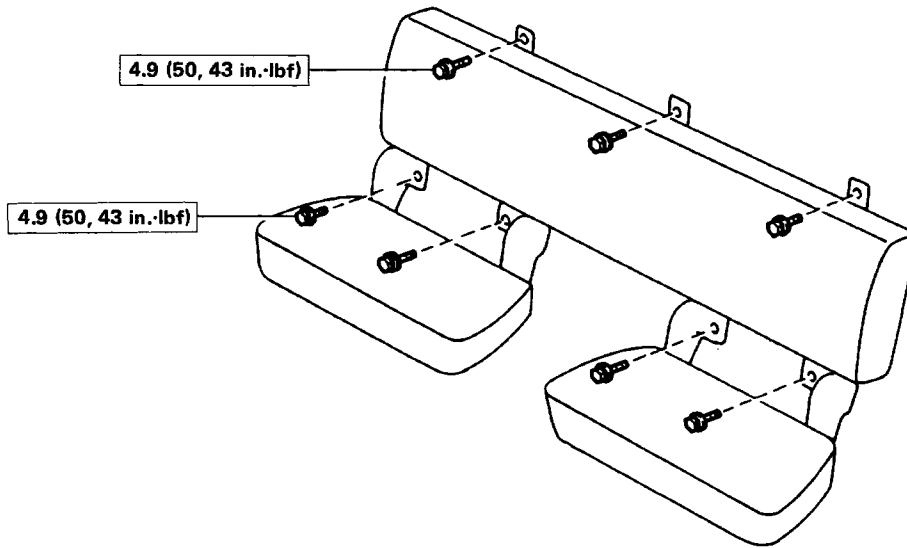

BO3272

**N·m (kgf·cm, ft·lbf)** : Specified torque

# SEAT BELT

## Front Seat Belt COMPONENTS

### Separate Seat

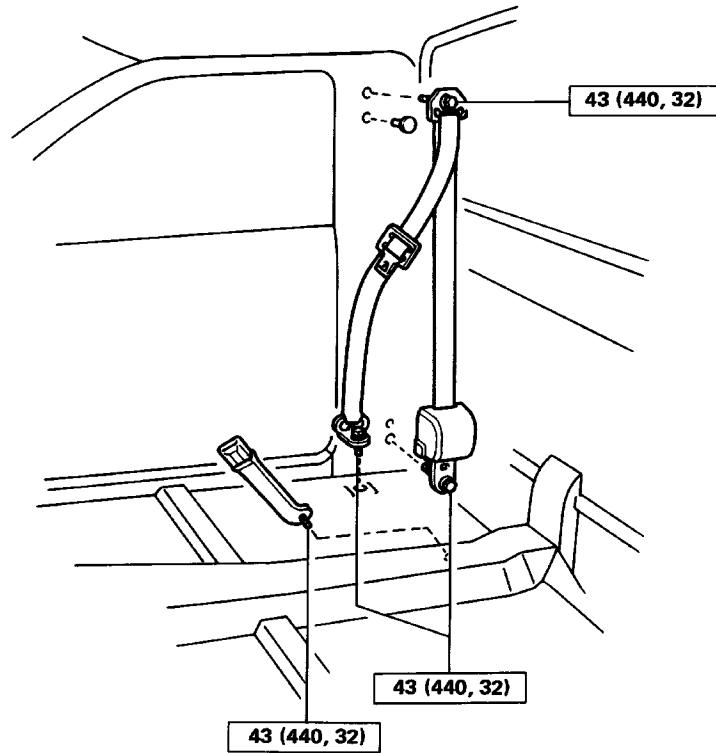

### Sprit Bench Seat and Bench Seat

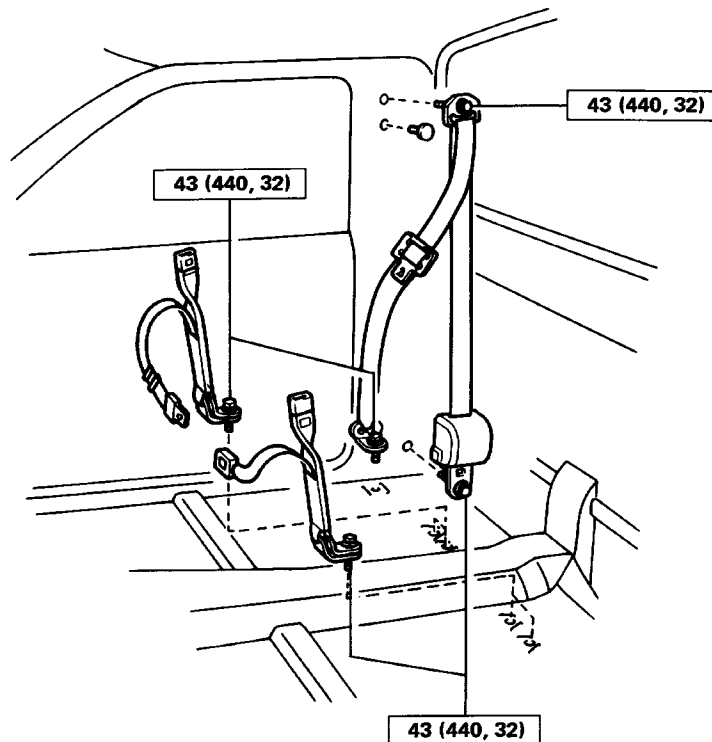

B03275  
B03274

**N·m (kgf·cm, ft·lbf)** : Specified torque

## Rear Jump Seat Belt COMPONENTS (Cont'd)

Xtra Cab

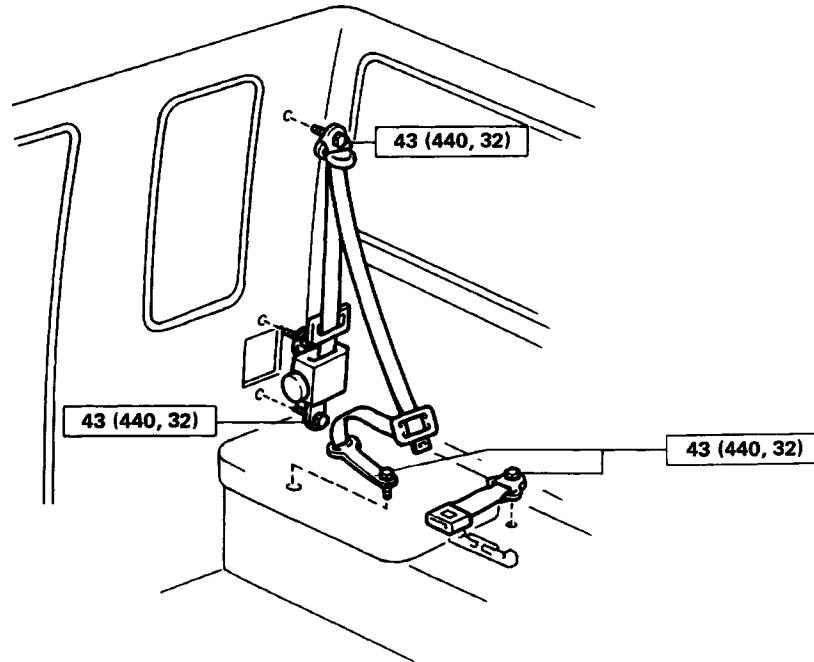

B03277

**N·m (kgf·cm, ft·lbf)** : Specified torque

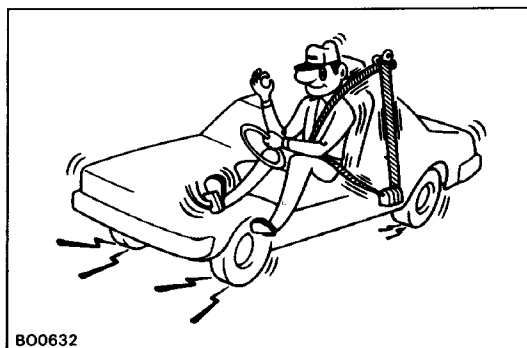

## SEAT BELT

### [Emergency Locking Retractor (ELR) Type]

#### 1. RUNNING TEST (IN SAFETY AREA)

- (a) Fasten the seat belt.
- (b) Drive the car at 10 mph (16 km/h) and make a very hard stop.
- (c) Check that the seat belt is locked and cannot be extended at this time.

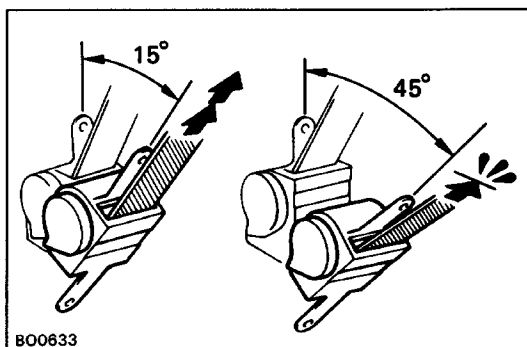

HINT: Conduct this test in safe area. If the belt does not lock, remove the belt mechanism assembly and conduct the following static check. Also, whenever installing a new belt assembly, verify the proper operation before installation.

#### 2. STATIC TEST

- (a) Remove the locking retractor assembly.
- (b) Tilt the retractor slowly.
- (e) Verify that the belt can be pulled out at a tilt of 15 degrees or less, and cannot be pulled out at over 45 degrees of tilt.

If a problem is found, replace the assembly.

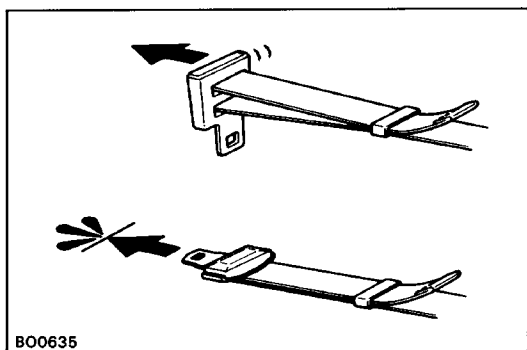

## CENTER SEAT BELT

### (Manual Type)

#### TESTING

- (a) Adjust the belt to the proper length.
- (b) Apply a firm load to the belt.
- (c) Verify that the belt does not extend.

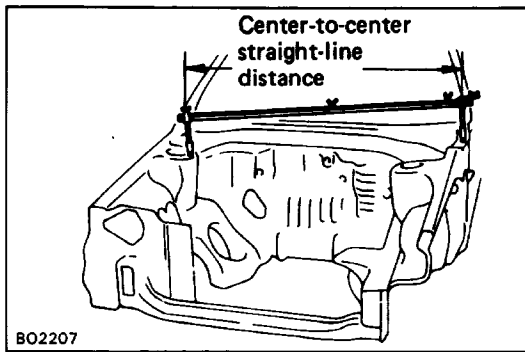

## BODY DIMENSIONS

### General Information

#### 1. BASIC DIMENSIONS

(a) There are two types of dimensions in the diagram.  
(Three-dimensional distance)

- Straight-line distance between the centers of two measuring points.

(Two-dimensional distance)

- Horizontal distance in forward/rearward between the centers of two measuring points.

- The height from an imaginary standard line.

(b) Incases in which only one dimension is given, left and right are symmetrical.

(c) The dimensions in the following drawing indicate actual distance. Therefore, please use the dimensions as a reference.

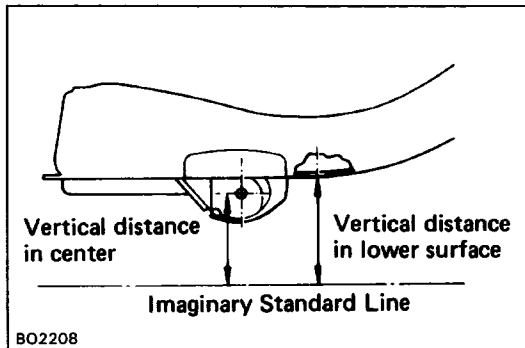

#### 2. MEASURING

(a) Basically, all measurements are to be done tracking gauge. For portions where it is not possible to use a tracking gauge, a tape measure should be used.

(b) Use only tracking gauge that has no looseness in the body, measuring plate, or pointers.

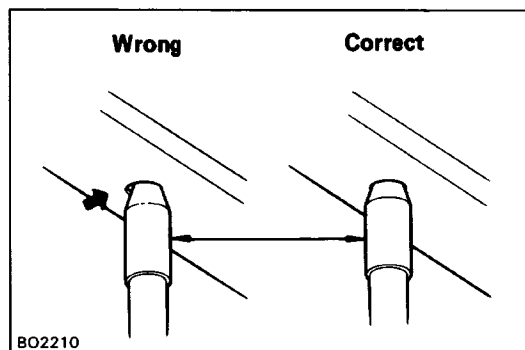
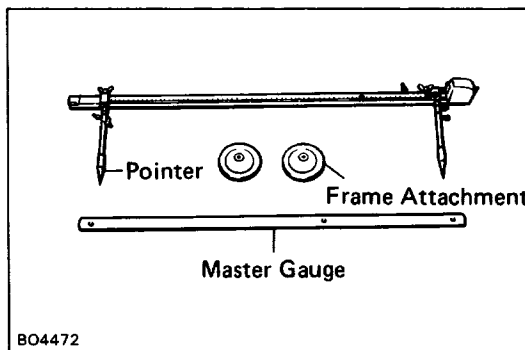

#### HINT:

1. The height of the left and right pointers must be equal.
  2. Always calibrate the tracking gauge before measuring or after adjusting the pointer height.
  3. Take care not to drop the tracking gauge or otherwise shock it.
  4. Confirm that the pointers are securely in the holes.
- (c) When using a tape measure, avoid twists and bends in the tape.

# Body Dimensions

**OVERHEAD VIEW**  
**(Three-Dimensional Distance)**  
**REGULAR CAB**

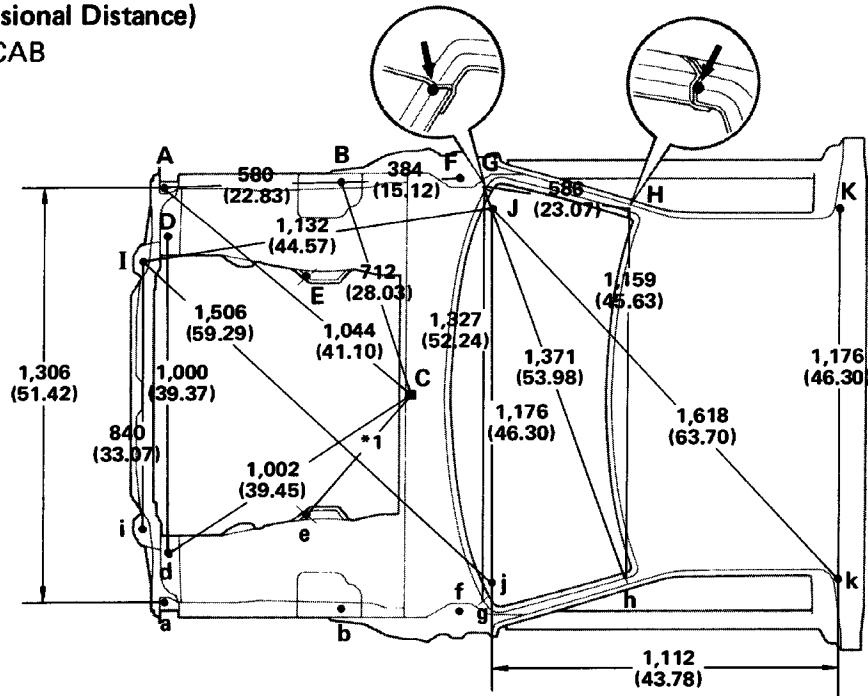

\*1: 2WD 655 (25.79)  
 4WD 688 (27.09)

**XTRA CAB**

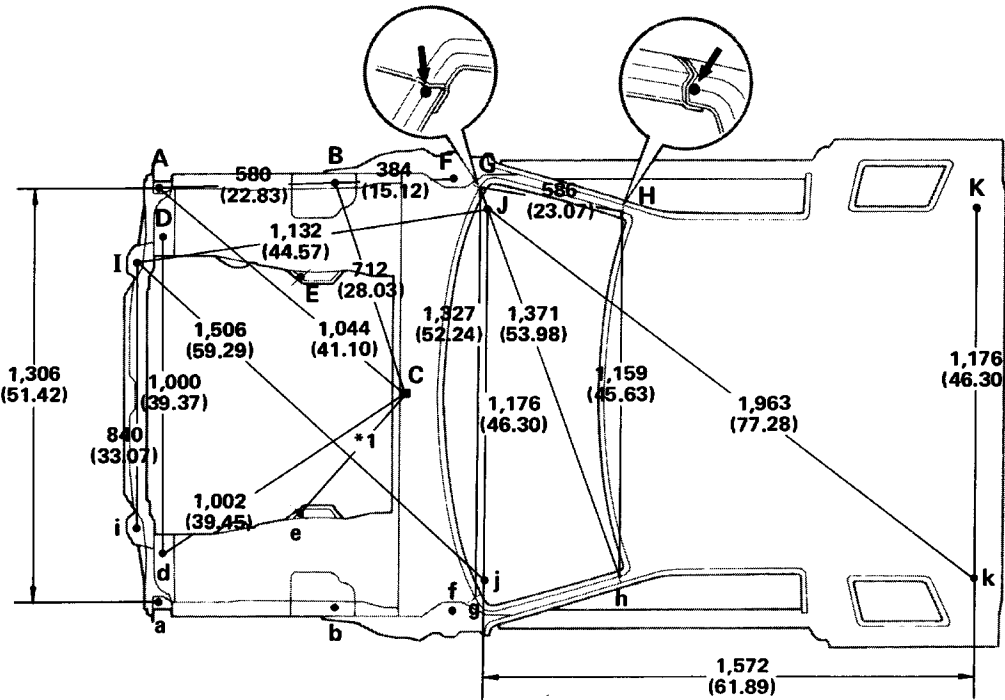

mm (in.)

BO3601  
 BO3602

Symbol	Name	Hole dia.	Symbol	Name	Hole dia.
A,a	Front fender installation nut	8 (0.31)	G,g	Front body pillar/Cowl panel adjoining portion	—
B,b	Front fender installation nut	8 (0.31)	H,h	Roof panel/Front body pillar adjoining portion	—
C	Cowl ventilation louver installation nut	7.5 x 7.5 (0.295 x 0.295)	I,i	Cab mounting hole	RH 11 (0.43) LH 15 x 12 (0.59 x 0.47)
D,d	Fender apron standard hole	25 (0.98)	J,j	Cab mounting hole	22 (0.87)
E,e	Fender apron seal installation hole	8 (0.31)	K,k	Cab mounting hole	RH 22 (0.87) LH 23 x 12 (0.91 x 0.47)
F,f	Cowl top panel standard hole	10 (0.39)			
—	—	—			

**FRONT VIEW**  
**(Three-Dimensional Distance)**  
**ALL MODELS**

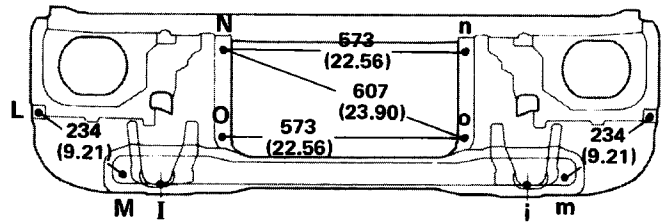

**REAR VIEW**  
**(Three-Dimensional Distance)**  
**ALL MODELS**

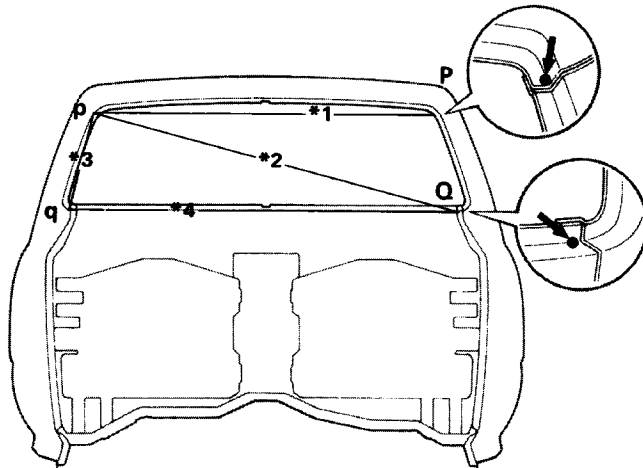

**SIDE VIEW**  
**(Three-Dimensional Distance)**  
**ALL MODELS**

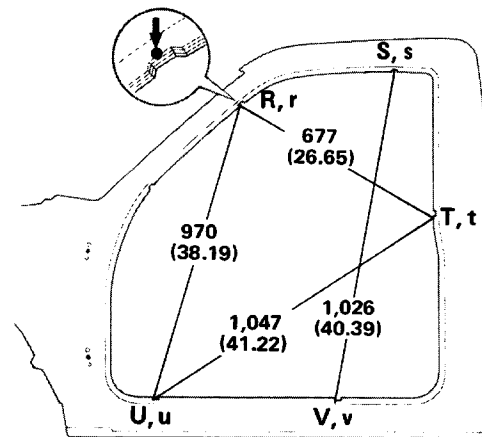

- \*1: Regular Cab 1,110 (43.70)  
Xtra Cab 1,104 (43.46)
- \*2: Regular Cab 1,216 (47.87)  
Xtra Cab 1,231 (48.46)
- \*3: Regular Cab 305 (12.01)  
Xtra Cab 346 (13.62)
- \*4: Regular Cab 1,248 (49.13)  
Xtra Cab 1,264 (49.76)

**NOTE:** For symbol, capital letters indicate right side of vehicle, small letters indicate left side of vehicle.

BO3603  
 BO3604 BO3605

mm (in.)

Symbol	Name	Hole dia.	Symbol	Name	Hole dia.
I, i	Cab mounting hole RH 11 (0.43) LH 15 x 12 (0.59 x 0.47)		Q, q	Back panel/Quarter panel adjoining portion	—
L, l	Front fender installation nut	7 (0.28)	R, r	Front body pillar assembly mark	—
M, m	Front crossmember standard hole	13 (0.51)	S, s	Roof side rail assembly mark	—
N, n	Radiator installation nut	9 (0.35)	T, t	Quarter panel assembly mark	—
O, o	Radiator installation nut	9 (0.35)	U, u	Rocker panel assembly mark	—
P, p	Roof panel/Quarter panel adjoining portion	—	V, v	Rocker panel assembly mark	—
			—	—	—

# Frame Dimensions

## 2WD Regular Cab: Short Wheel Base Models

(Three-Dimensional Distance)

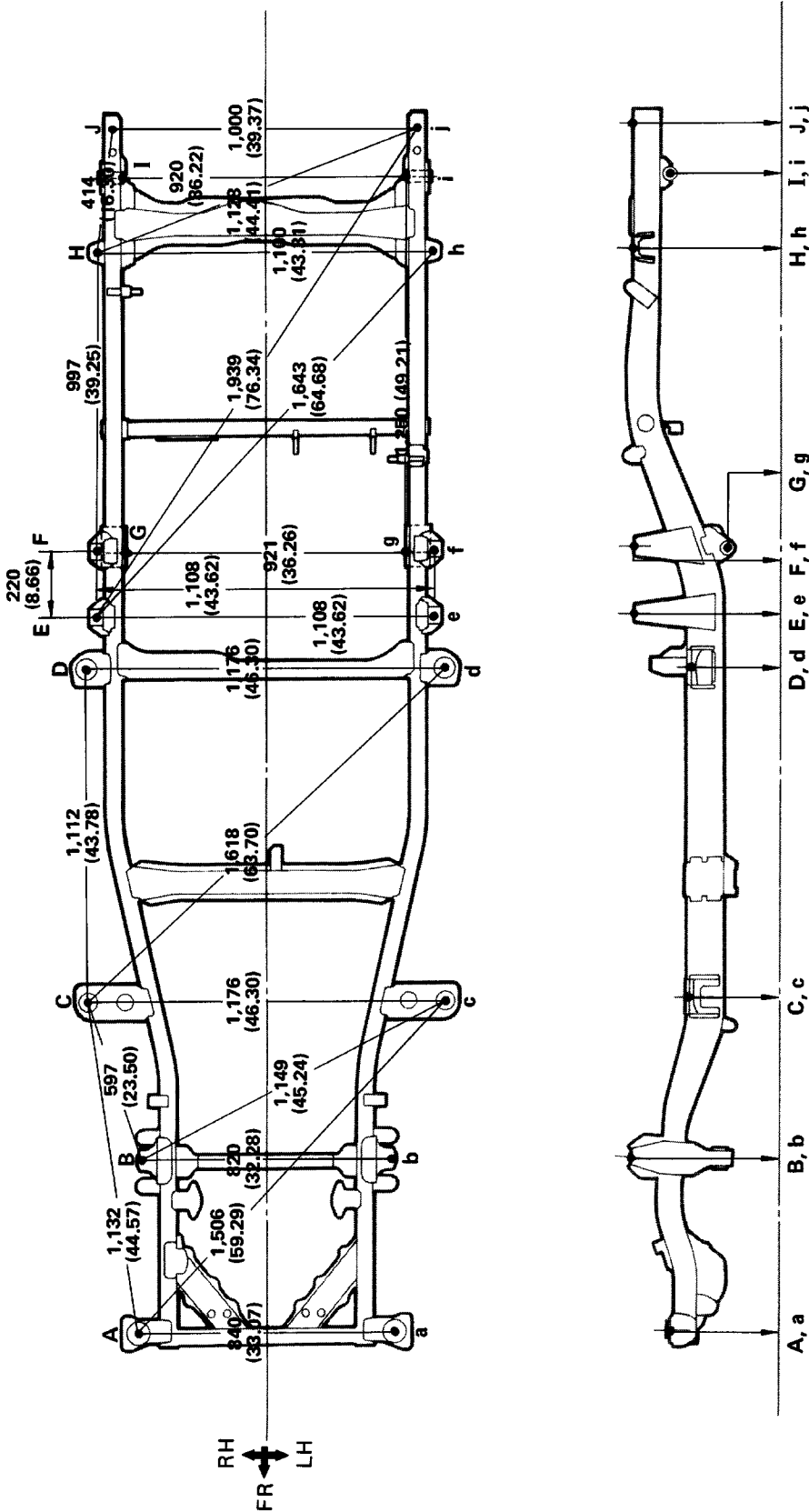

Symbol	Name	Hole dia.	Symbol	Name	Hole dia.
A,a	Cab mounting hole	24 (0.94)	F,f	Rear body mounting hole	17 (0.67)
B,b	Shock absorber installation hole	16 (0.63)	G,g	Rear spring front hanger hole — inner	14.5 (0.571)
C,c	Cab mounting hole	60 (2.36)	H,h	Rear body mounting hole	17 (0.67)
D,d	Cab mounting hole	70 (2.76)	I,i	Rear spring rear hanger hole — inner	30.35 (1.1949)
E,e	Rear body mounting hole	17 (0.67)	J,j	Rear body mounting hole	18 x 21 (0.71 x 0.83)



## 2WD Regular Cab: Short Wheel Base Models

(Two-Dimensional Distance)

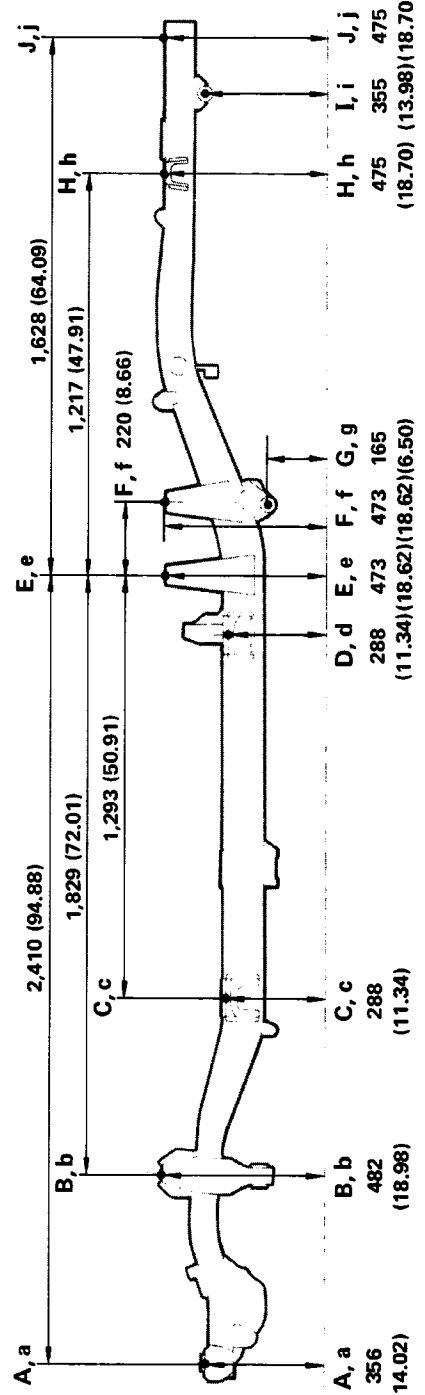
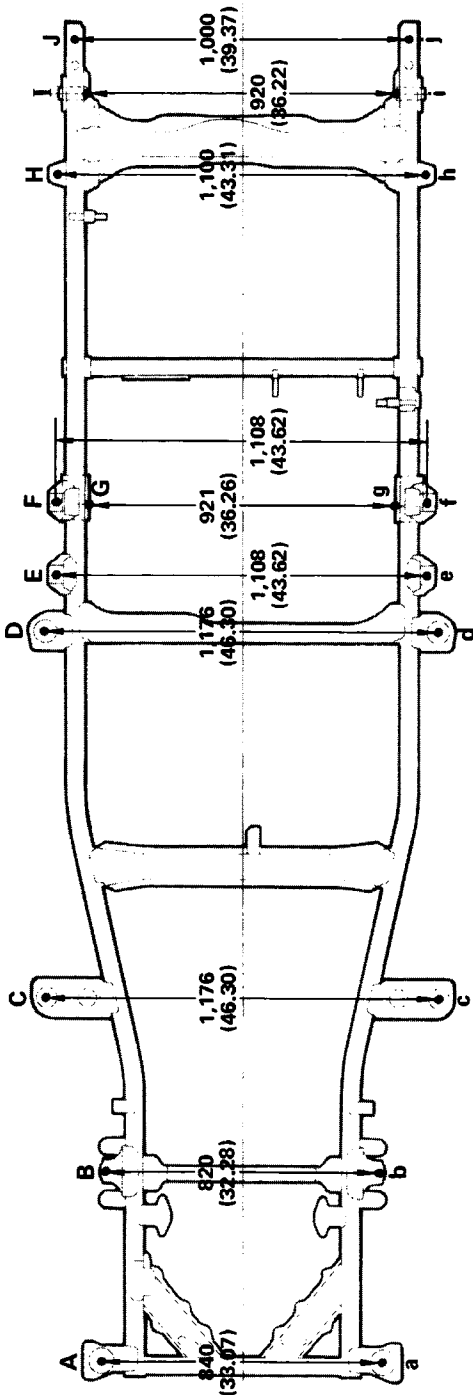

Imaginary Standard Line

Wheel base: 2,615 (102.95)

Symbol	Name	Hole dia.	Symbol	Name	Hole dia.
A,a	Cab mounting hole	24 (0.94)	F,f	Rear body mounting hole	17 (0.67)
B,b	Shock absorber installation hole	16 (0.63)	G,g	Rear spring front hanger hole - inner	14.5 (0.571)
C,c	Cab mounting hole	60 (2.36)	H,h	Rear body mounting hole	17 (0.67)
D,d	Cab mounting hole	70 (2.76)	I,i	Rear spring rear hanger hole - inner	30.35 (1.1949)
E,e	Rear body mounting hole	17 (0.67)	J,j	Rear body mounting hole	18 x 21 (0.71 x 0.83)

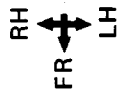

## 2WD Regular Cab: Long Wheel Base Models

(Three-Dimensional Distance)

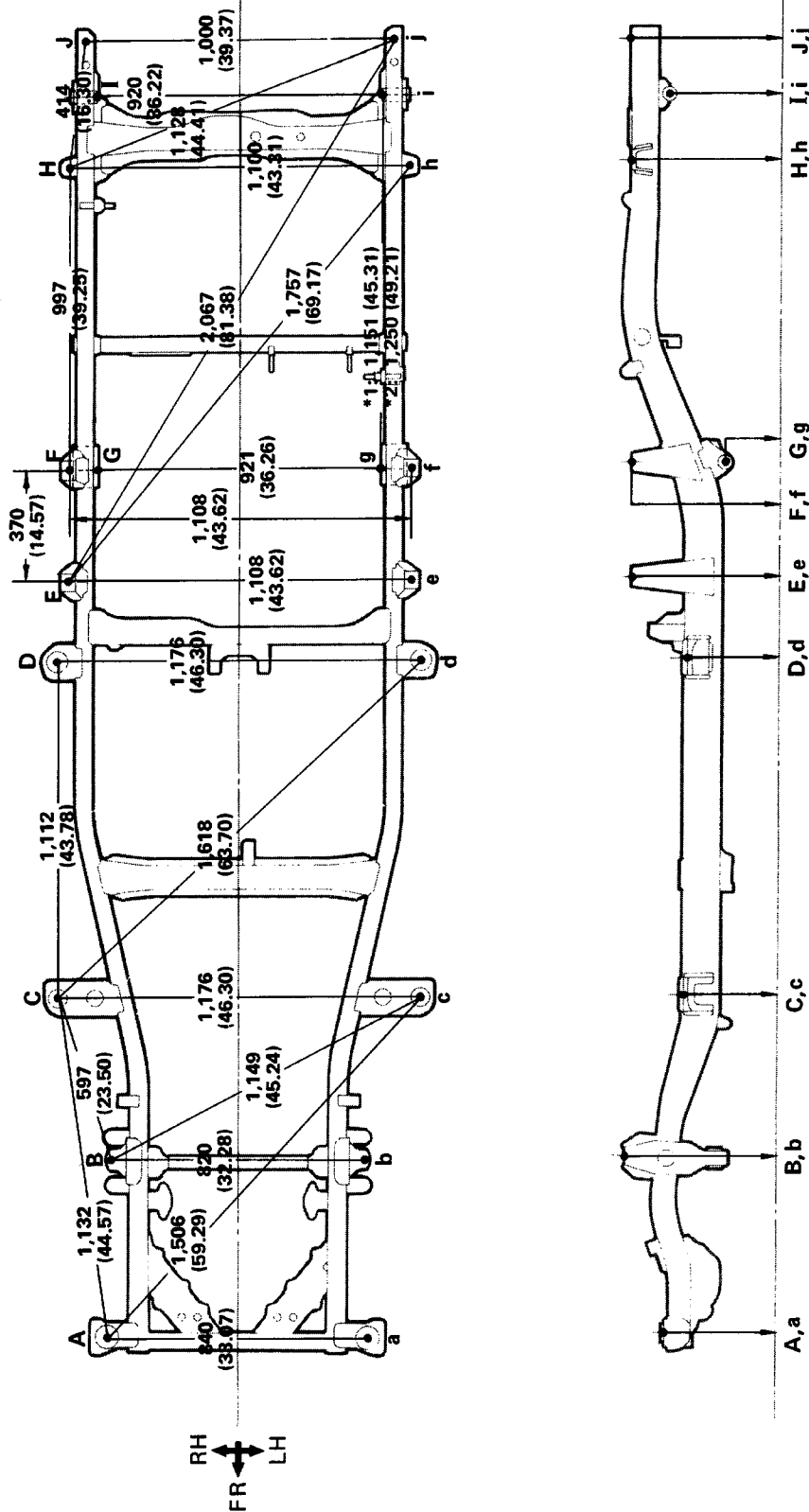

\*1: Loading Capacity 1.0 ton, and Cab and Chassis Models  
 \*2: Loading Capacity 0.5 ton Models

Symbol	Name	Hole dia.	Symbol	Name	Hole dia.
A,a	Cab mounting hole	24 (0.94)	G,g	Rear spring front hanger hole — inner	14.5 (0.571)
B,b	Shock absorber installation hole	16 (0.63)	H,h	Rear body mounting hole	17 (0.67)
C,c	Cab mounting hole	60 (2.36)	I,i	Rear spring rear hanger hole — inner	30.35 (1.1949)
D,d	Cab mounting hole	70 (2.76)	J,j	Rear body mounting hole	18 x 21 (0.71 x 0.83)
E,e	Rear body mounting hole	17 (0.67)			
F,f	Rear body mounting hole	17 (0.67)			

## 2WD Regular Cab: Long Wheel Base Models

(Two-Dimensional Distance)

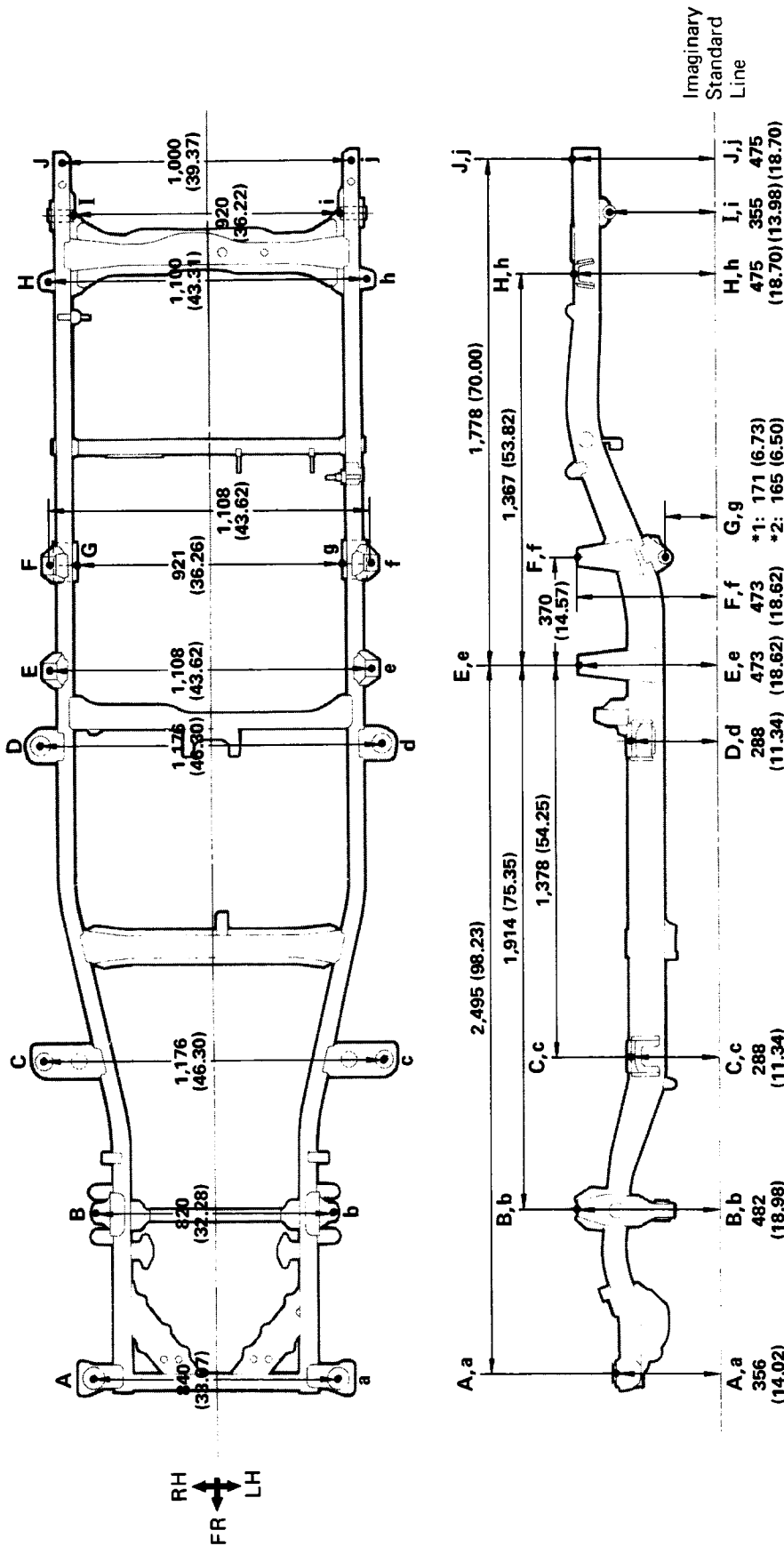

\*1: Loading Capacity: 1.0 ton, and Cab and Chassis Models  
 \*2: Loading Capacity: 0.5 ton Models

Wheel Base: 2,850 (112.20)

mm (in.)

## 2WD Regular Cab: Super Long Wheel Base Models

(Three-Dimensional Distance)

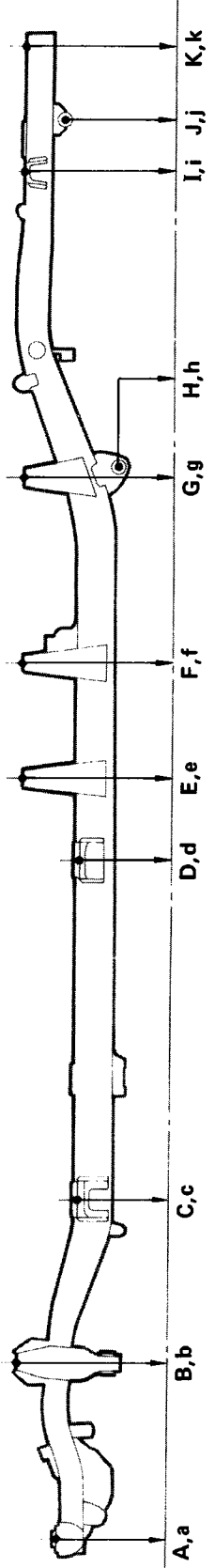
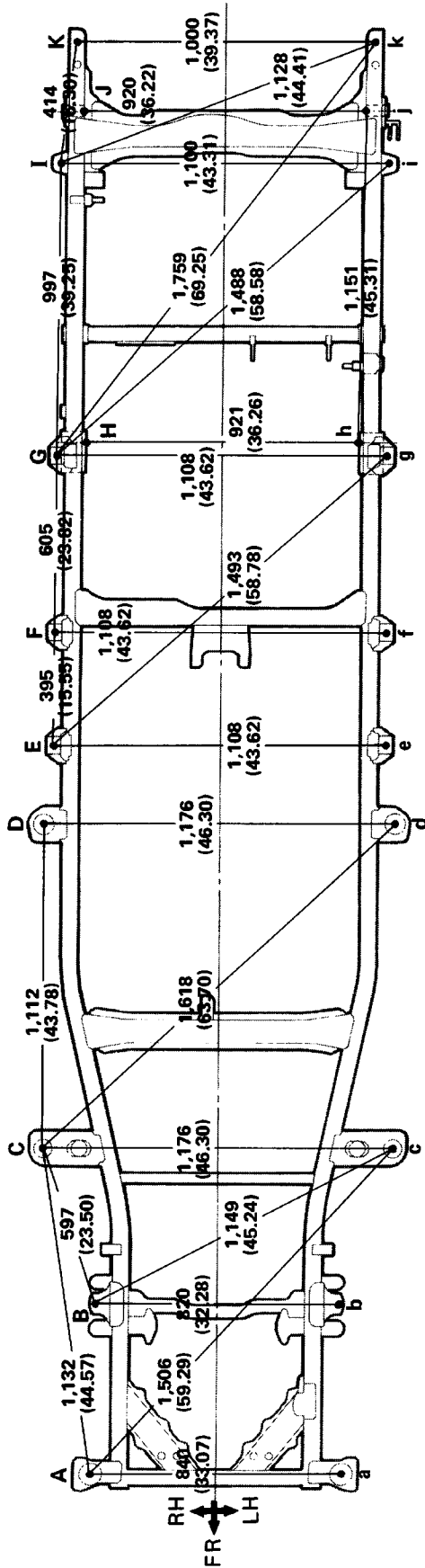

Symbol	Name	Hole dia.	Symbol	Name	Hole dia.
A,a	Cab mounting hole	24 (0.94)	G,g	Rear body mounting hole	17 (0.67)
B,b	Shock absorber installation hole	16 (0.63)	H,h	Rear spring front hanger hole - inner	14.6 (0.575)
C,c	Cab mounting hole	60 (2.36)	I,i	Rear body mounting hole	17 (0.67)
D,d	Cab mounting hole	70 (2.76)	J,j	Rear spring rear hanger hole - inner	30.35 (1.1949)
E,e	Rear body mounting hole	17 (0.67)	K,k	Rear body mounting hole	18 x 21 (0.71 x 0.83)
F,f	Rear body mounting hole	17 (0.67)			

## 2WD Regular Cab: Super Long Wheel Base Models

(Two-Dimensional Distance)

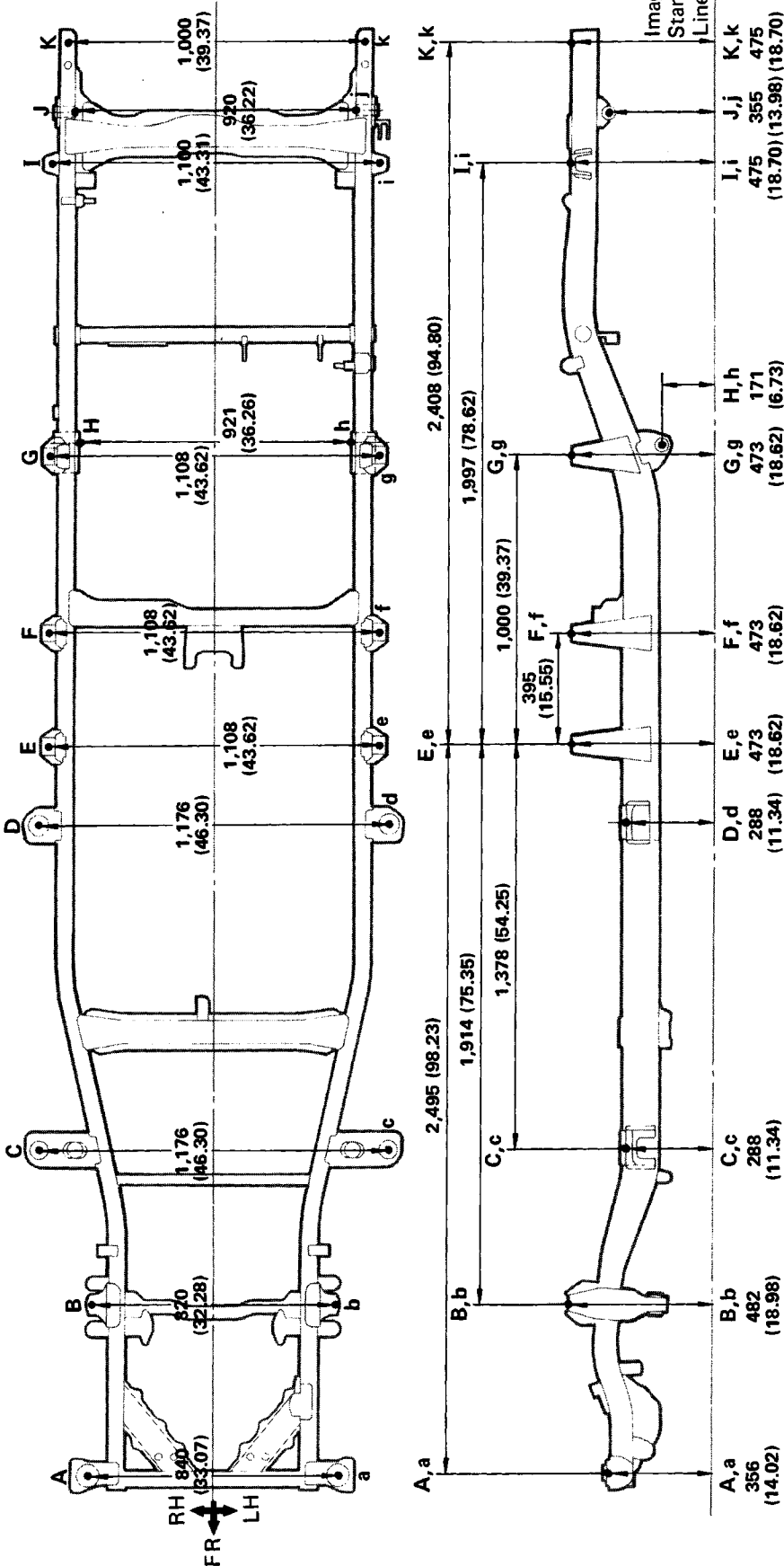

Wheel Base: 3,480 (137.01)

Symbol	Name	Hole dia.	Symbol	Name	Hole dia.
A,a	Cab mounting hole	24 (0.94)	G,g	Rear body mounting hole	17 (0.67)
B,b	Shock absorber installation hole	16 (0.63)	H,h	Rear spring front hanger hole - inner	14.6 (0.575)
C,c	Cab mounting hole	60 (2.36)	I,i	Rear body mounting hole	17 (0.67)
D,d	Cab mounting hole	70 (2.76)	J,j	Rear spring rear hanger hole - inner	30.35 (1.1949)
E,e	Rear body mounting hole	17 (0.67)	K,k	Rear body mounting hole	18 x 21 (0.71 x 0.83)
F,f	Rear body mounting hole	17 (0.67)			

## 2WD Xtra Cab Models

(Three-Dimensional Distance)

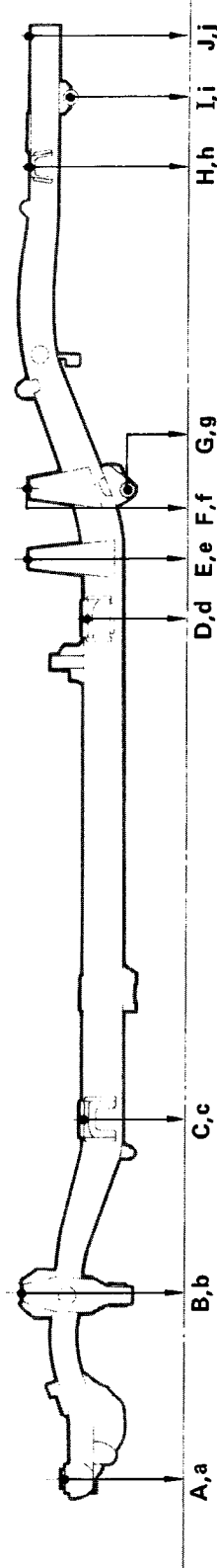
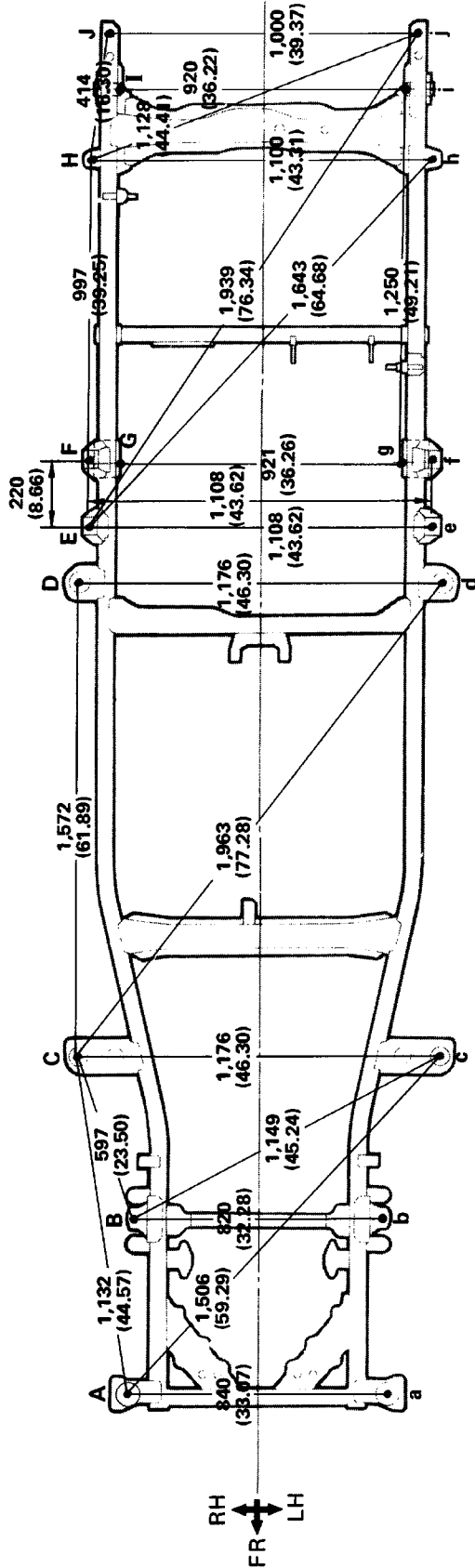

mm (in.)

Symbol	Name	Hole dia.	Symbol	Name	Hole dia.
A,a	Cab mounting hole	24 (0.94)	G,g	Rear spring front hanger hole — inner	14.5 (0.571)
B,b	Shock absorber installation hole	16 (0.63)	H,h	Rear body mounting hole	17 (0.67)
C,c	Cab mounting hole	60 (2.36)	I,i	Rear spring rear hanger hole — inner	30.35 (1.1949)
D,d	Cab mounting hole	70 (2.76)	J,j	Rear body mounting hole	18 x 21 (0.71 x 0.83)
E,e	Rear body mounting hole	17 (0.67)			
F,f	Rear body mounting hole	17 (0.67)			

### 2WD Xtra Cab Models

(Two-Dimensional Distance)

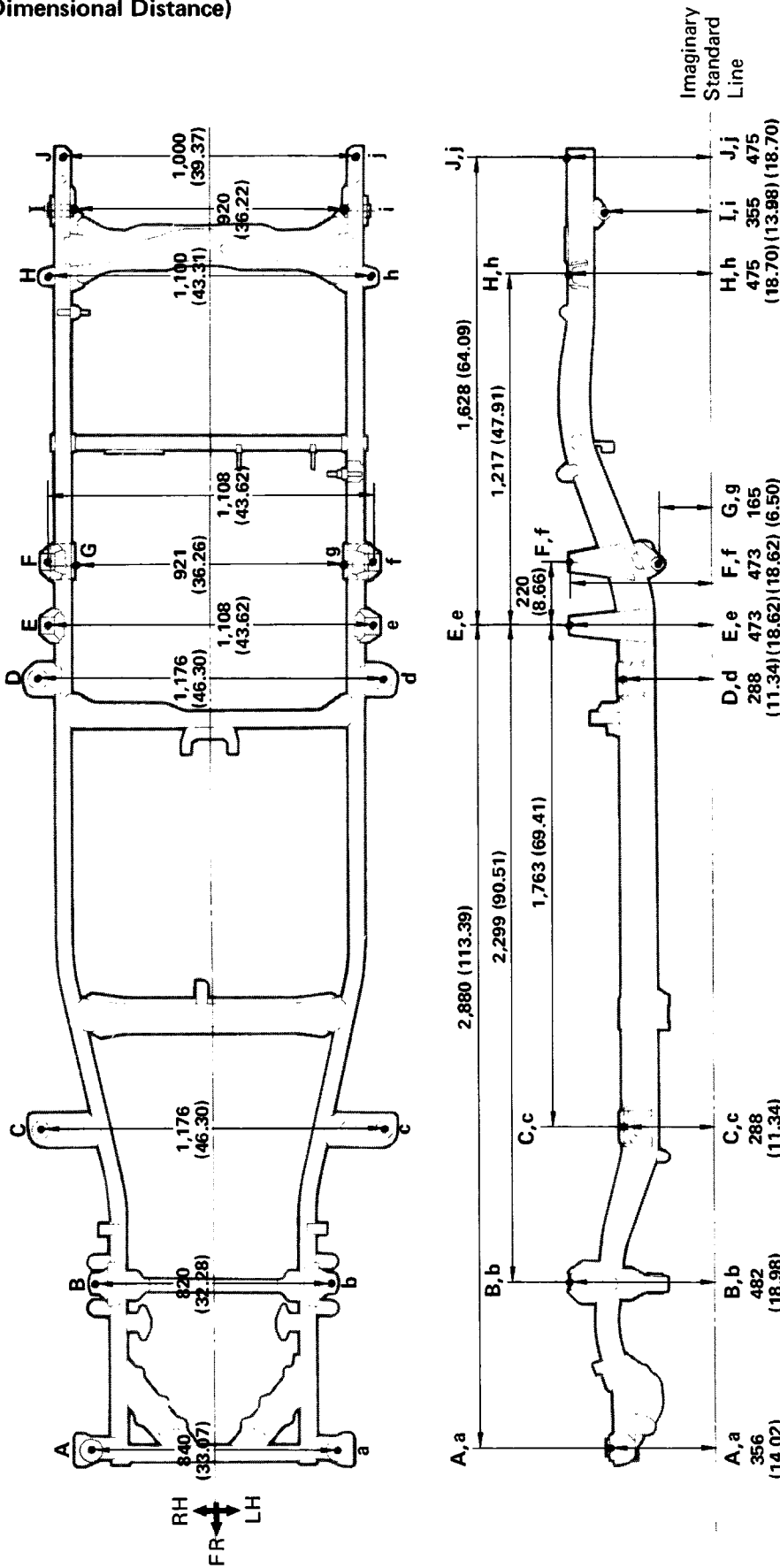

Wheel Base: 3,085 (121.46)

Symbol	Name	Hole dia.	Symbol	Name	Hole dia.
A,a	Cab mounting hole	24 (0.94)	G,g	Rear spring front hanger hole - inner	14.5 (0.571)
B,b	Shock absorber installation hole	16 (0.63)	H,h	Rear body mounting hole	17 (0.67)
C,c	Cab mounting hole	60 (2.36)	I,i	Rear spring rear hanger hole - inner	30.35 (1.1949)
D,d	Cab mounting hole	70 (2.76)	J,j	Rear body mounting hole	18 x 21 (0.71 x 0.83)
E,e	Rear body mounting hole	17 (0.67)			
F,f	Rear body mounting hole	17 (0.67)			

### 4WD Regular Cab: Short Wheel Base Models

(Three-Dimensional Distance)

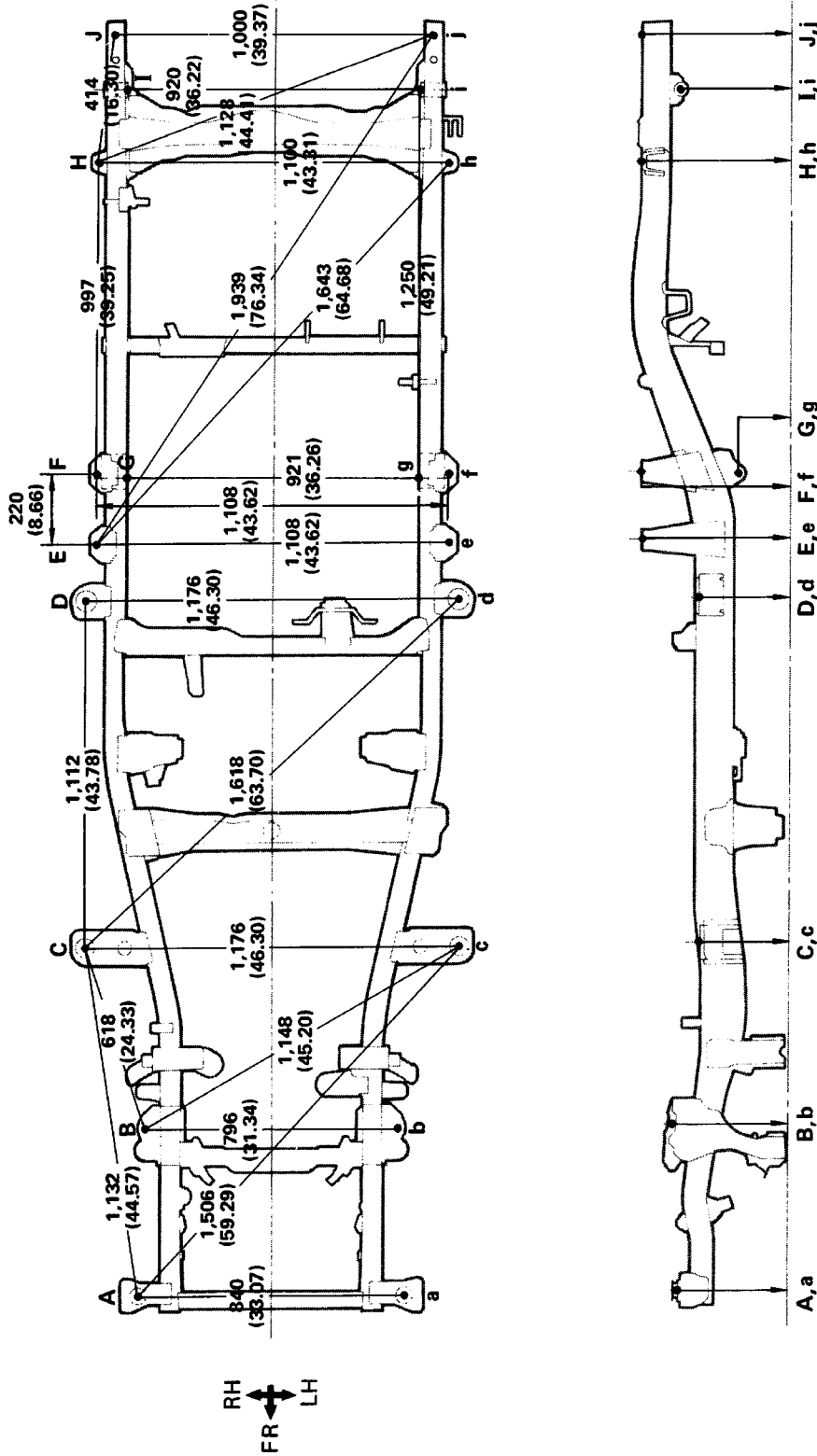

Symbol	Name	Hole dia.	Symbol	Name	Hole dia.
A,a	Cab mounting hole	24 (0.94)	G,g	Rear spring front hanger hole - inner	14.5 (0.571)
B,b	Shock absorber installation hole	16 (0.63)	H,h	Rear body mounting hole	17 (0.67)
C,c	Cab mounting hole	60 (2.36)	I,i	Rear spring rear hanger hole - inner	30.35 (1.1949)
D,d	Cab mounting hole	70 (2.76)	J,j	Rear body mounting hole	18 x 21 (0.71 x 0.83)
E,e	Rear body mounting hole	17 (0.67)			
F,f	Rear body mounting hole	17 (0.67)			



### 4WD Regular Cab: Short Wheel Base Models

(Two-Dimensional Distance)

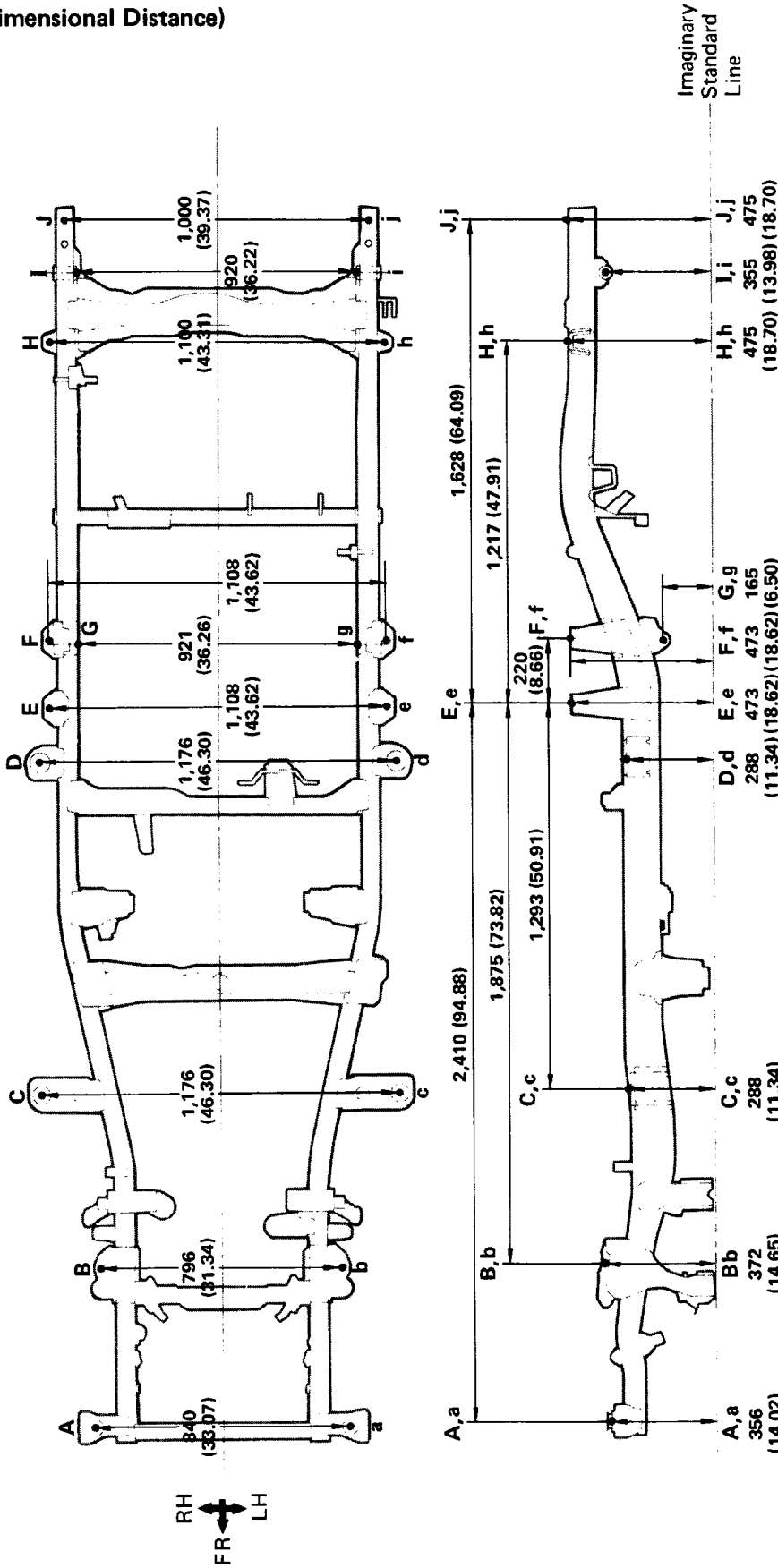

Wheel Base: 2,625 (103.35)

Symbol	Name	Hole dia.	Symbol	Name	Hole dia.
A,a	Cab mounting hole	24 (0.94)	G,g	Rear spring front hanger hole - inner	14.5 (0.571)
B,b	Shock absorber installation hole	16 (0.63)	H,h	Rear body mounting hole	17 (0.67)
C,c	Cab mounting hole	60 (2.36)	I,i	Rear spring rear hanger hole - inner	30.35 (1.1949)
D,d	Cab mounting hole	70 (2.76)	J,j	Rear body mounting hole	18 x 21 (0.71 x 0.83)
E,e	Rear body mounting hole	17 (0.67)			
F,f	Rear body mounting hole	17 (0.67)			

### 4WD Regular Cab: Long Wheel Base Models

(Three-Dimensional Distance)

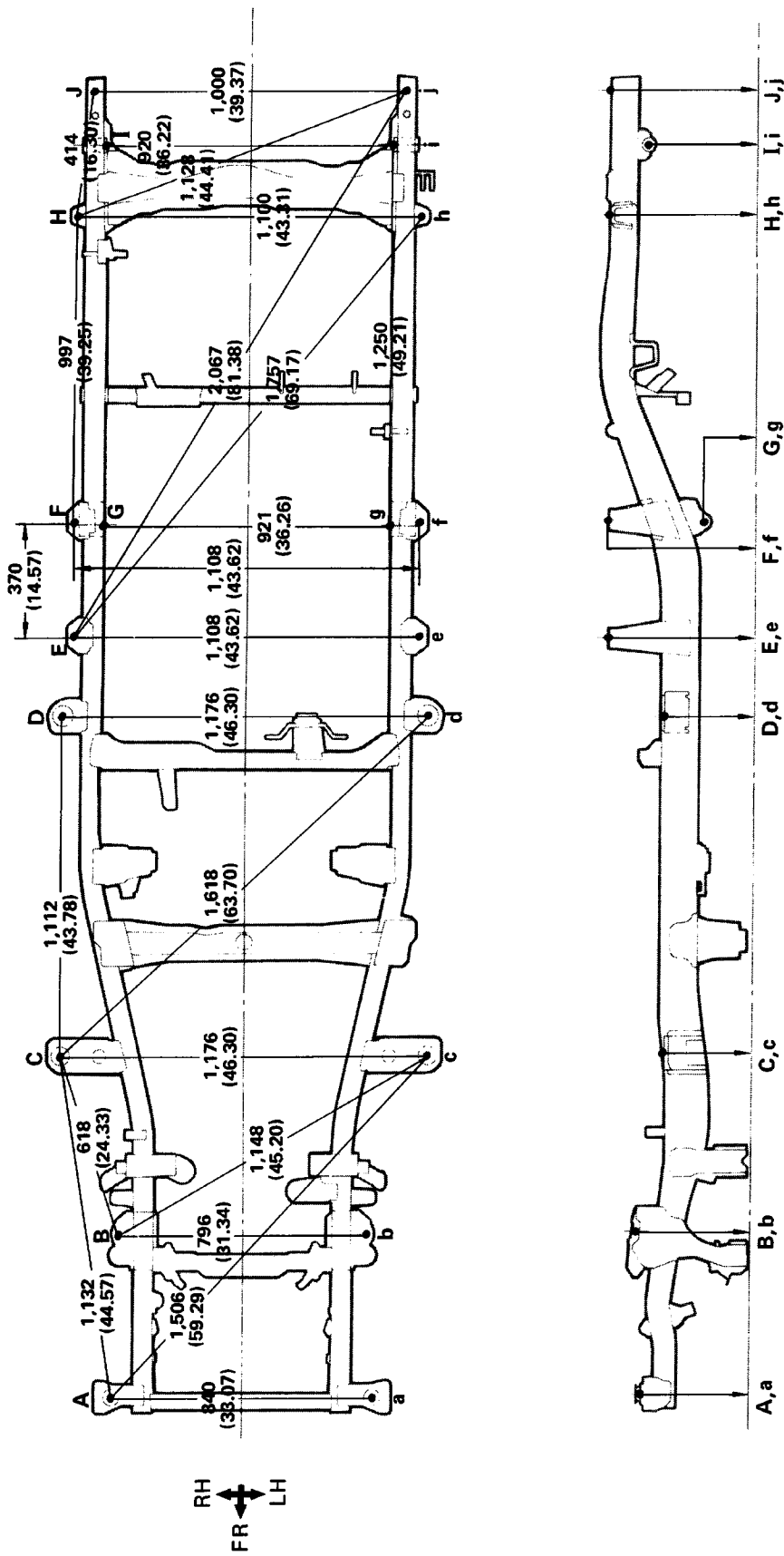

Symbol	Name	Hole dia.	Symbol	Name	Hole dia.
A,a	Cab mounting hole	24 (0.94)	G,g	Rear spring front hanger hole - inner	14.5 (0.571)
B,b	Shock absorber installation hole	16 (0.63)	H,h	Rear body mounting hole	17 (0.67)
C,c	Cab mounting hole	60 (2.36)	I,i	Rear spring rear hanger hole - inner	30.35 (1.1949)
D,d	Cab mounting hole	70 (2.76)	J,j	Rear body mounting hole	18 x 21 (0.71 x 0.83)
E,e	Rear body mounting hole	17 (0.67)			
F,f	Rear body mounting hole	17 (0.67)			

### 4WD Regular Cab: Long Wheel Base Models

(Two-Dimensional Distance)

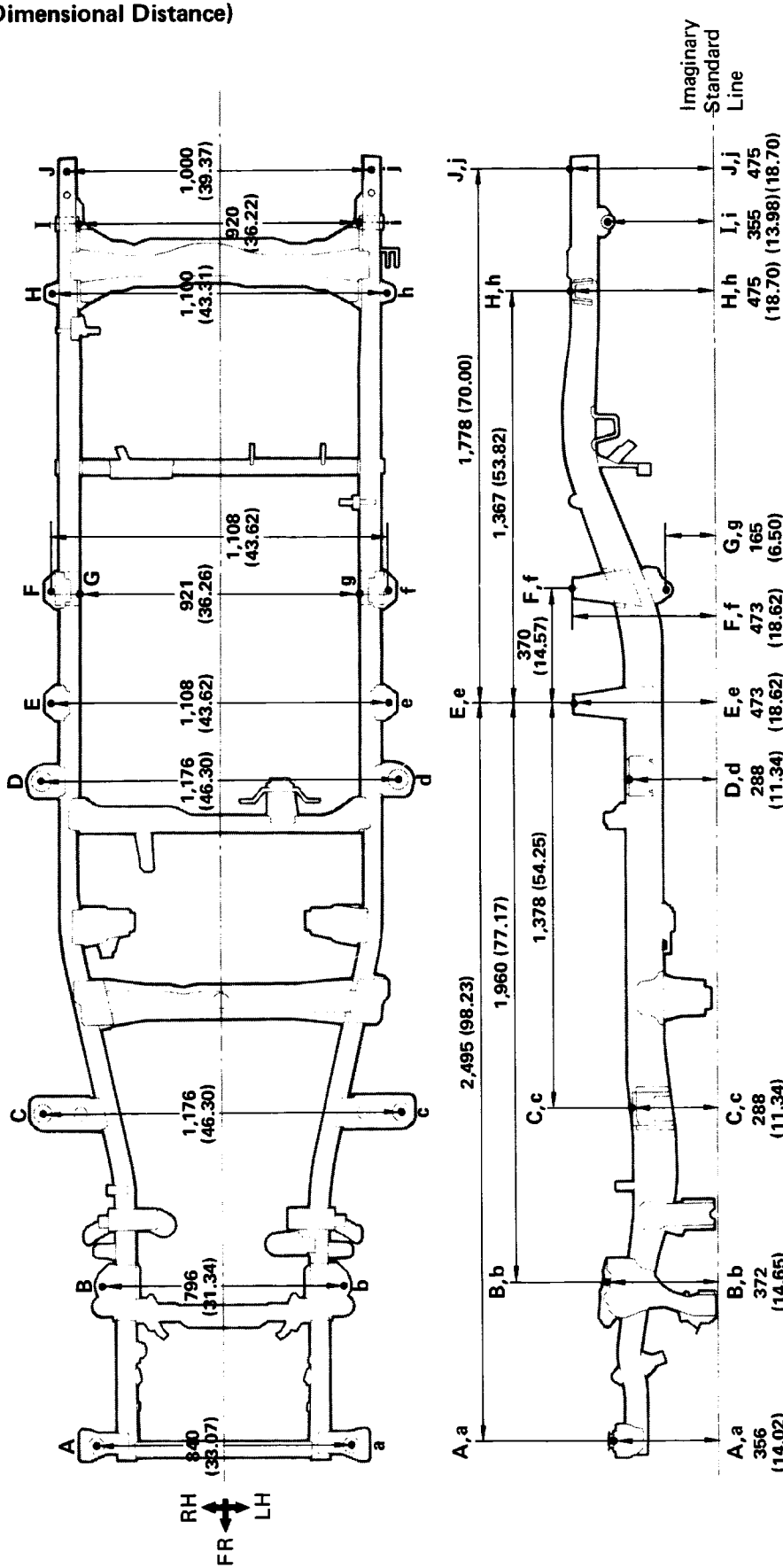

mm (in.)

Symbol	Name	Hole dia.	Symbol	Name	Hole dia.
A,a	Cab mounting hole	24 (0.94)	G,g	Rear spring front hanger hole - inner	14.5 (0.571)
B,b	Shock absorber installation hole	16 (0.63)	H,h	Rear body mounting hole	17 (0.67)
C,c	Cab mounting hole	60 (2.36)	I,i	Rear spring rear hanger hole - inner	30.35 (1.1949)
D,d	Cab mounting hole	70 (2.76)	J,j	Rear body mounting hole	18 x 21 (0.71 x 0.83)
E,e	Rear body mounting hole	17 (0.67)			
F,f	Rear body mounting hole	17 (0.67)			

# 4WD Xtra Cab Models

(Three-Dimensional Distance)

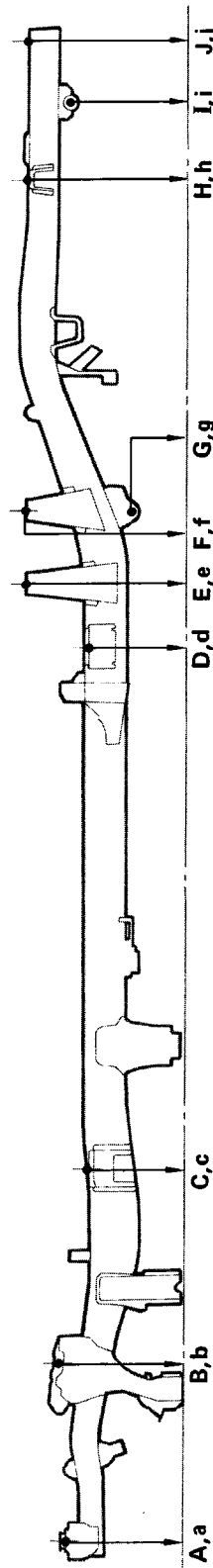
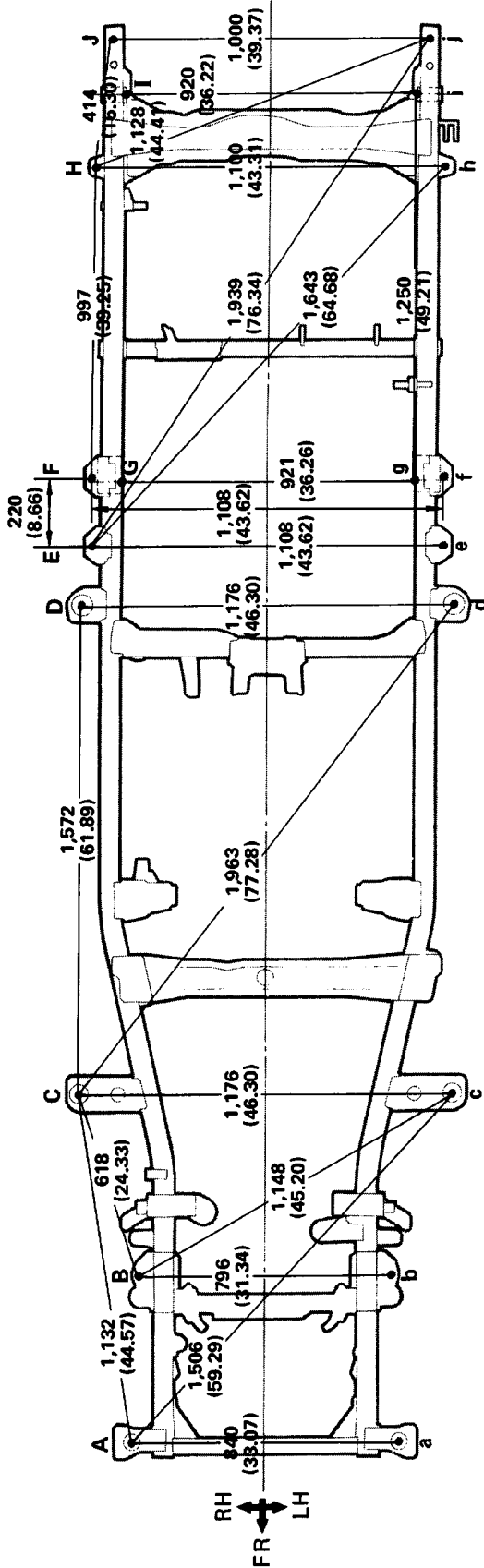

mm (in.)

Symbol	Name	Hole dia.	Symbol	Name	Hole dia.
A,a	Cab mounting hole	24 (0.94)	G,g	Rear spring front hanger hole — inner	14.5 (0.571)
B,b	Shock absorber installation hole	16 (0.63)	H,h	Rear body mounting hole	17 (0.67)
C,c	Cab mounting hole	60 (2.36)	I,i	Rear spring rear hanger hole — inner	30.35 (1.1949)
D,d	Cab mounting hole	70 (2.76)	J,j	Rear body mounting hole	18 x 21 (0.71 x 0.83)
E,e	Rear body mounting hole	17 (0.67)			
F,f	Rear body mounting hole	17 (0.67)			

# 4WD Xtra Cab Models

(Two-Dimensional Distance)

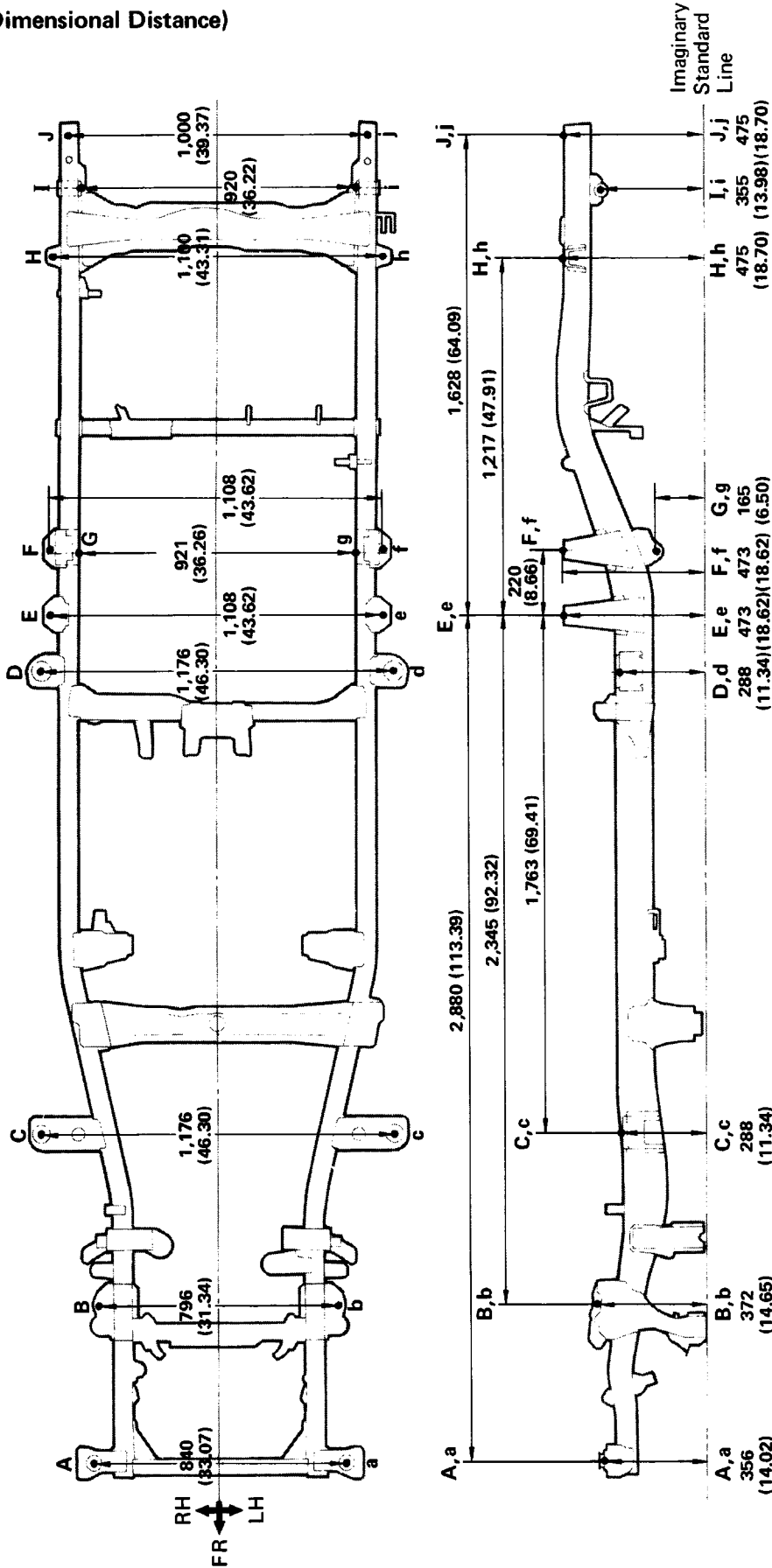

Wheel Base: 3,095 (121.85)

Symbol	Name	Hole dia.	Symbol	Name	Hole dia.
A,a	Cab mounting hole	24 (0.94)	G,g	Rear spring front hanger hole - inner	14.5 (0.571)
B,b	Shock absorber installation hole	16 (0.63)	H,h	Rear body mounting hole	17 (0.67)
C,c	Cab mounting hole	60 (2.36)	I,i	Rear spring rear hanger hole - inner	30.35 (1.1949)
D,d	Cab mounting hole	70 (2.76)	J,j	Rear body mounting hole	18 x 21 (0.71 x 0.83)
E,e	Rear body mounting hole	17 (0.67)			
F,f	Rear body mounting hole	17 (0.67)			

# AIR CONDITIONING SYSTEM

## GENERAL INFORMATION

### REFRIGERATION SYSTEM

Prevention of Refrigerant Release and Excessive quantities Refrigerant (CFCs) for automobile air conditionings is believed to cause harm by depleting the ozone layer which helps to protect us from the ultraviolet rays of the sun. Therefore, it is necessary to prevent release of refrigerant to the atmosphere and to use the minimum amount when servicing the air conditioning.

#### 1. USE RECOVERY MACHINE TO RECOVER REFRIGERANT

When discharging refrigerant from the system as follows, use a recovery machine to recover the refrigerant.

- Before replacing parts on the refrigerant line.
- When moisture or air gets in the refrigerant line.
- When excess refrigerant is charged.

#### NOTICE:

- When handling the recovery machine, always follow the directions given in the instruction manual.
- After recovery, the amount of compressor oil removed must be measured and the same amount added to the system.

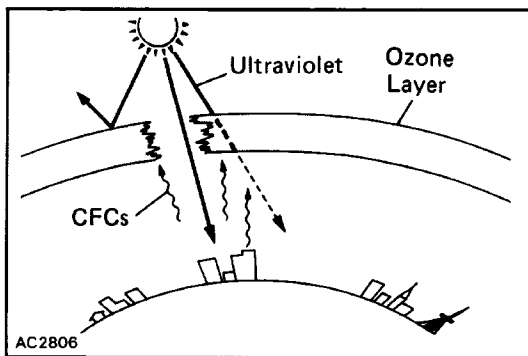

AC2806

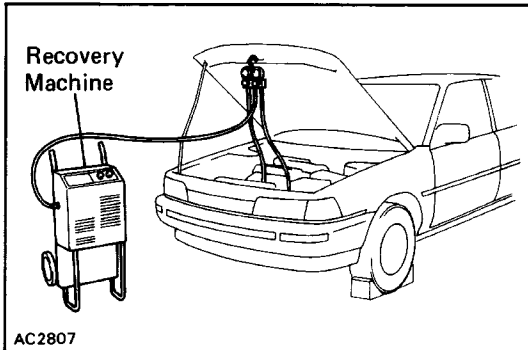

AC2807

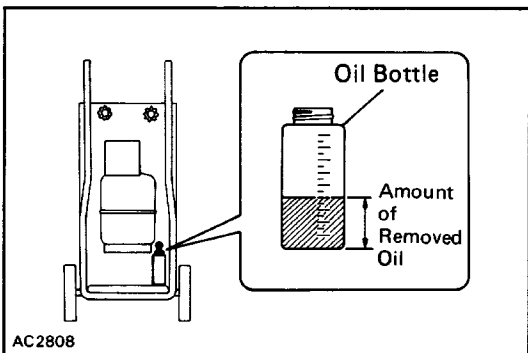

AC2808

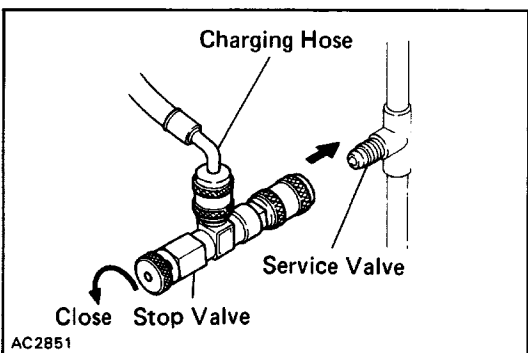

AC2851

#### 2. USE CHARGING HOSES WITH STOP VALVE WHEN INSTALLING MANIFOLD GAUGE SET

To prevent release of refrigerant, using charging hoses with a stop valve when installing the manifold gauge set to the service valves on the refrigerant line.

#### 3. TIGHTEN CONNECTING PARTS SECURELY

Follow the notices about tightening connecting parts in step 6 on page [AC-4](#).

#### 4. PROPERLY EVACUATE AIR FROM REFRIGERANT SYSTEM

To prevent release and wasteful use of refrigerant, evacuate air with care from refrigeration system as follows;

- Do not evacuate before recovering refrigerant in system.

- Do not perform repeat evacuation of system.

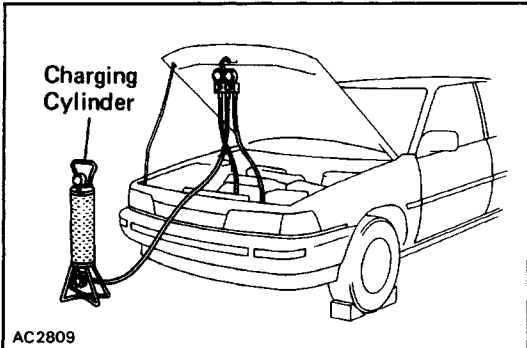
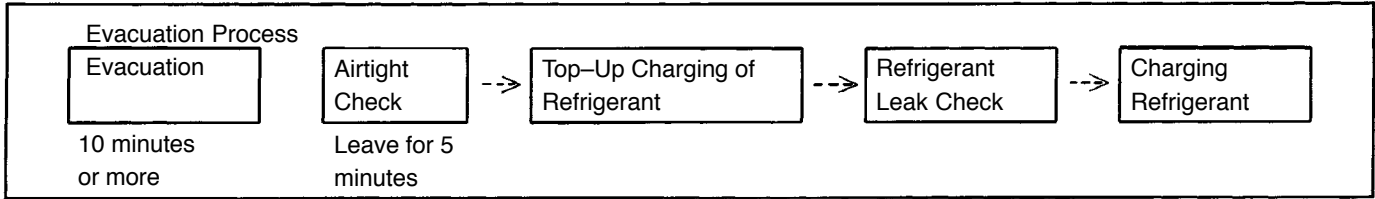

**6. USE CHARGING CYLINDER TO CHARGE PROPER AMOUNT OF REFRIGERANT**

To prevent excessive use of refrigerant due to overcharging, use a charging cylinder to charge the proper amount of refrigerant.

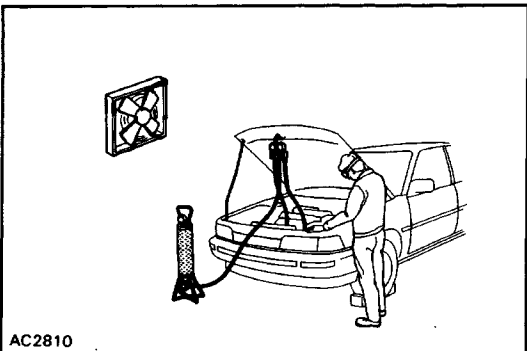

**Handling Precautions for Refrigerant**

1. DO NOT HANDLE REFRIGERANT IN AN ENCLOSED AREA OR NEAR AN OPEN FLAME
2. ALWAYS WEAR EYE PROTECTION

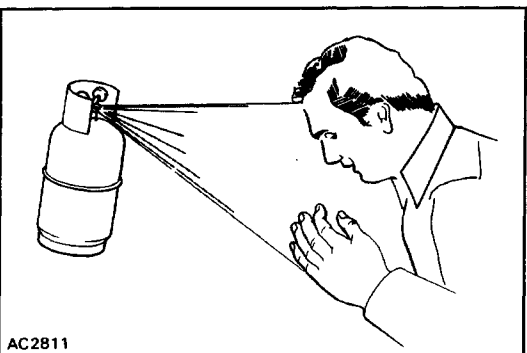

**3. BE CAREFUL THAT LIQUID REFRIGERANT DOES NOT GET IN YOUR EYES OR ON YOUR SKIN**

If liquid refrigerant gets in your eyes or on your skin;

(a) Wash the area with lots of cool water.

**CAUTION: Do not rub your eyes or skin.**

(b) Apply clean petroleum jelly to the skin.

(c) Go immediately to a physician or hospital for professional treatment.

**CAUTION: Do not attempt to treat yourself.**

**Handling Precautions for Refrigerant Container**

1. NEVER HEAT CONTAINER OR EXPOSE IT TO NAKED FLAME
2. BE CAREFUL NOT TO DROP CONTAINER AND NOT TO APPLY PHYSICAL SHOCKS TO IT



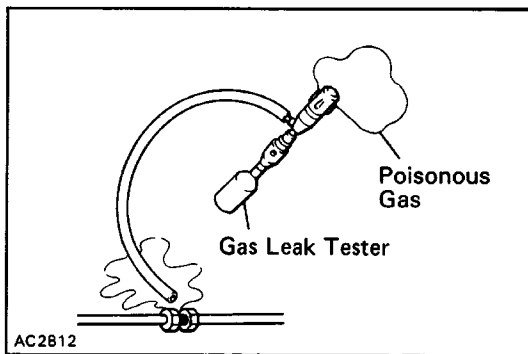

## Handling Precautions for Gas-Cylinder Type Gas Leak Tester

1. BEFORE USING TESTER MAKE SURE THAT THERE ARE NO FLAMMABLE SUBSTANCES NEARBY
2. BE CAREFUL NOT TO INHALE POISONOUS GAS

If refrigerant gas comes in contact with flame, a poisonous gas is produced. During leak tests, do not inhale any gas.

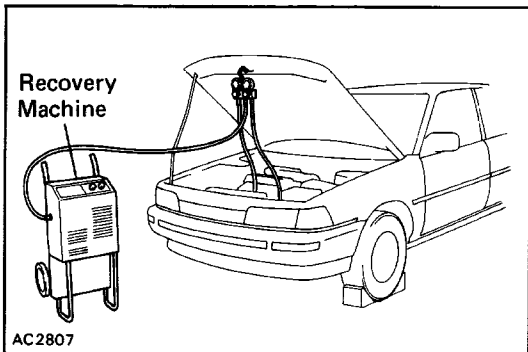

## Precautions When Replacing Parts in Refrigerant line

1. RECOVER REFRIGERANT IN SYSTEM BEFORE REMOVING PARTS

Using a recovery machine, recover refrigerant in system before removing the parts.

**NOTICE:** Do not release refrigerant to atmosphere.

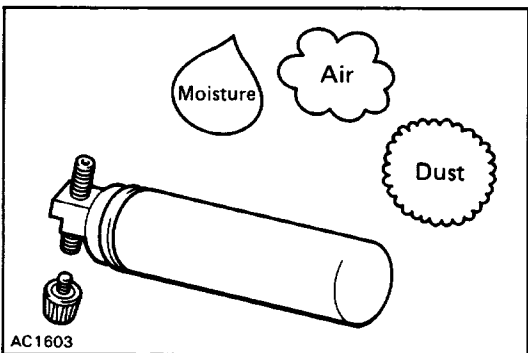

2. INSERT PLUG IMMEDIATELY IN DISCONNECTED PARTS

Insert a plug immediately in the disconnected parts to prevent the entry of moisture and dust.

3. DO NOT REMOVE PLUG FROM NEW PARTS UNTIL IMMEDIATELY BEFORE INSTALLATION

4. DO NOT USE BURNER FOR BENDING OR LENGTHENING OPERATIONS ON TUBE

If the tubes are heated with a burner, a layer of oxidation forms inside the tube, causing the same kind of trouble as an accumulation of dust.

5. DISCHARGE GAS IN NEW COMPRESSOR FROM CHARGING VALVE BEFORE INSTALLING IT

If the gas in new compressor is not discharged first, compressor oil will spray out with gas when the plug is removed.

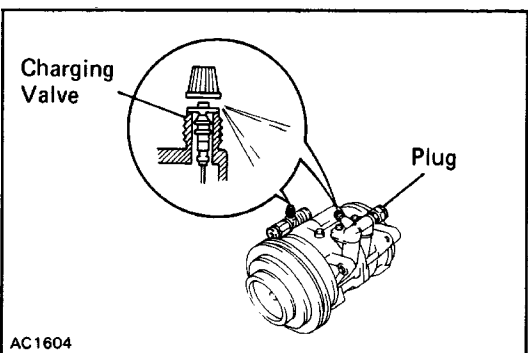

6. TIGHTEN CONNECTING PARTS SECURELY

Securely tighten the connecting parts to prevent leaking of refrigerant gas.

- Apply a few drops of compressor oil to O-ring fittings for easy tightening and to prevent leaking of refrigerant gas.
- Tighten the nuts using two wrenches to avoid twisting the tube.

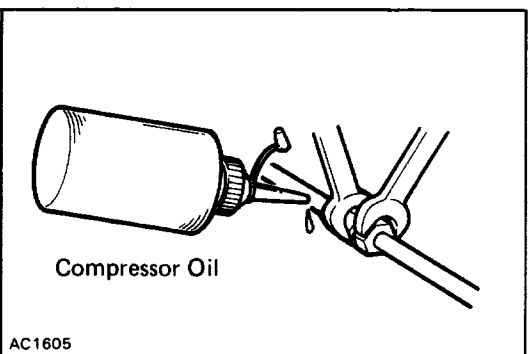

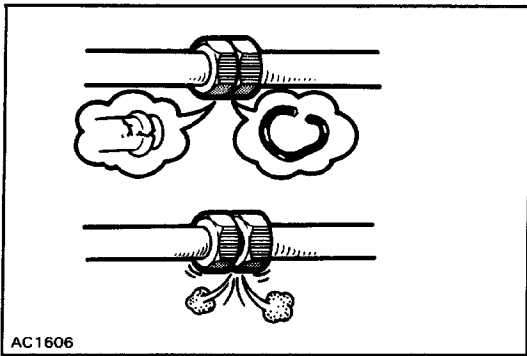

- Tighten the O-ring fittings or the bolted type fittings to the specified torque.

### Precautions When Charging Refrigerant

#### 1. DO NOT OPERATE COMPRESSOR WITHOUT ENOUGH REFRIGERANT IN REFRIGERANT CYCLE

If there is not enough refrigerant in the refrigerant cycle, oil lubrication will be insufficient and compressor burnout may occur, so take care to avoid this.

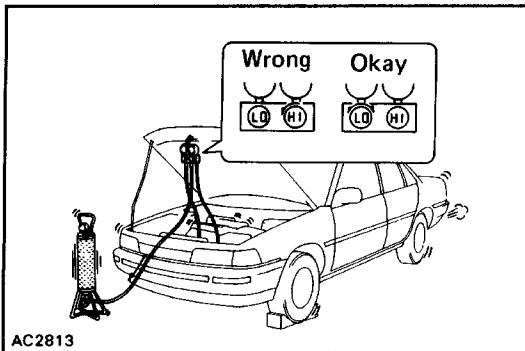

#### 2. DO NOT OPEN HIGH PRESSURE VALVE OF MANIFOLD GAUGE WITH COMPRESSOR OPERATING

If the high pressure valve is opened, refrigerant flows in the reverse direction and could cause the charging cylinder to rupture, so open and close the low pressure valve only.

#### 3. BE CAREFUL NOT TO OVERCHARGE WITH REFRIGERANT IN SYSTEM

If refrigerant is overcharged, it causes trouble such as insufficient cooling, poor fuel economy, engine overheating etc.

#### ELECTRICAL PARTS

Before removing and inspecting the electrical parts, set the ignition switch to the LOCK position and disconnect the negative (–) terminal cable from the battery..

# AIR CONDITIONING SYSTEM CIRCUIT

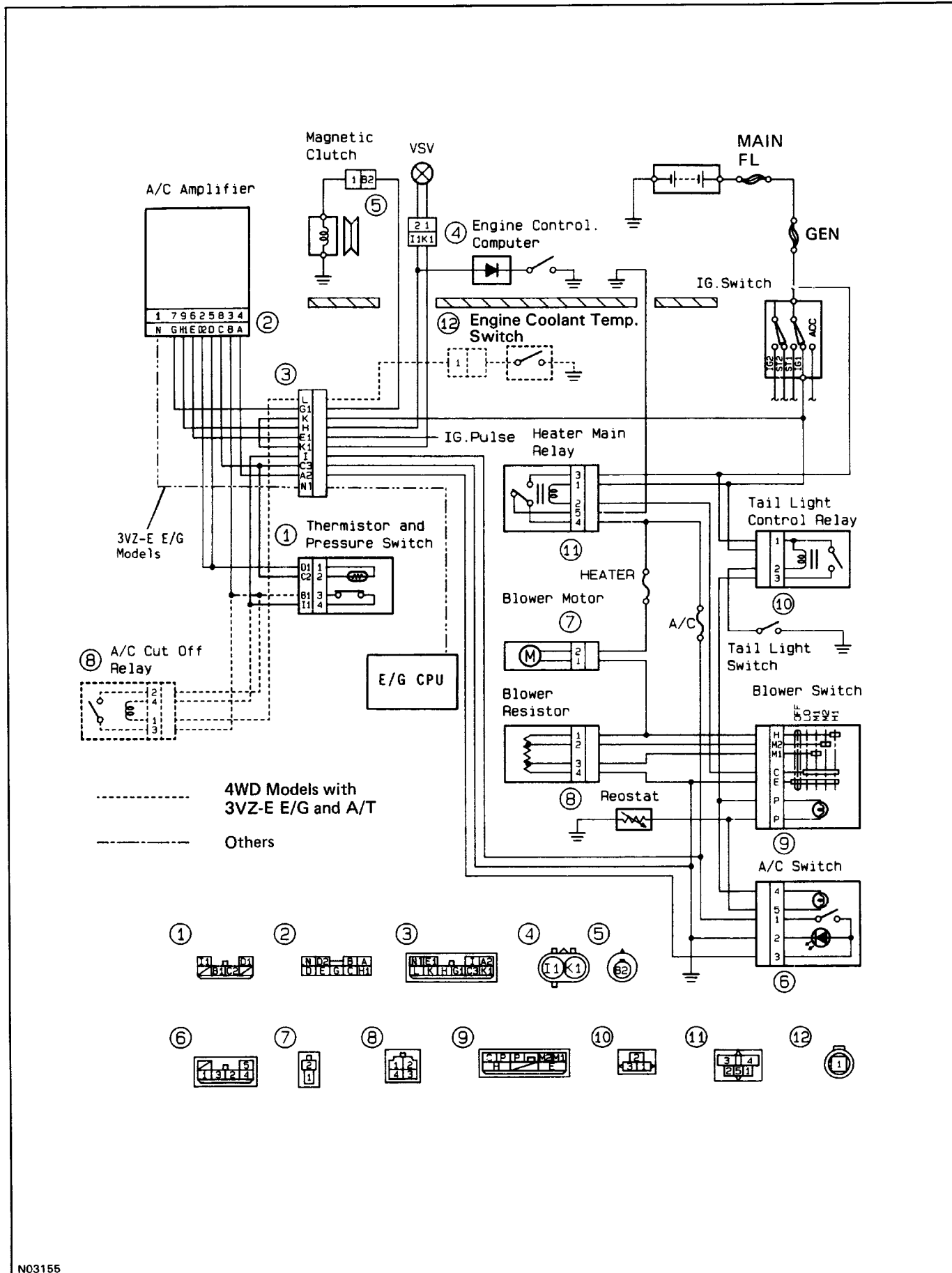

# SYSTEM COMPONENTS

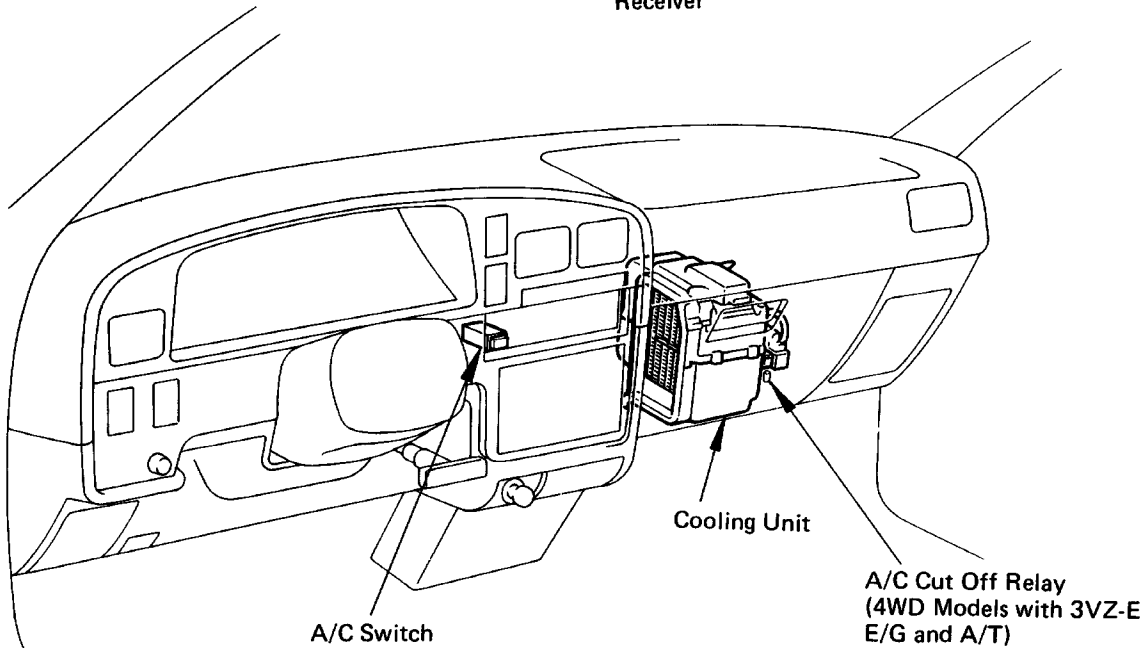
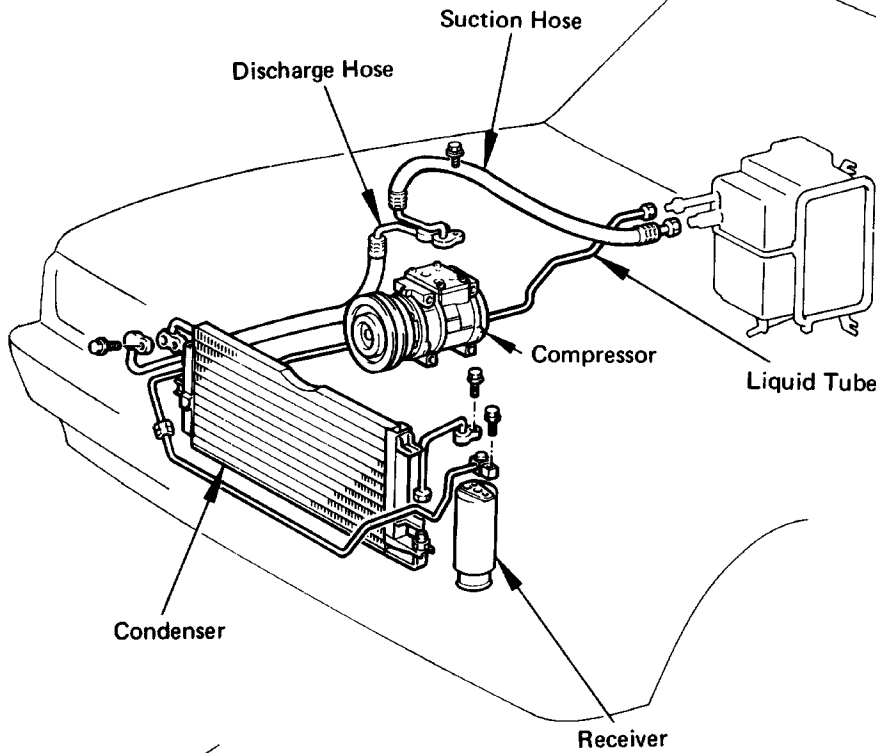

Specified Torque N·m (kgf·cm, ft·lbf)

	0.31 in. Tube	14 (140, 10)
	0.50 in. Tube	23 (230, 17)
	0.62 in. Tube	32 (330, 24)
Bolted Type	For Compressor	25 (250, 18)
	For Condenser	13 (130, 9)
	For Receiver	5 (55, 48 in.·lbf)

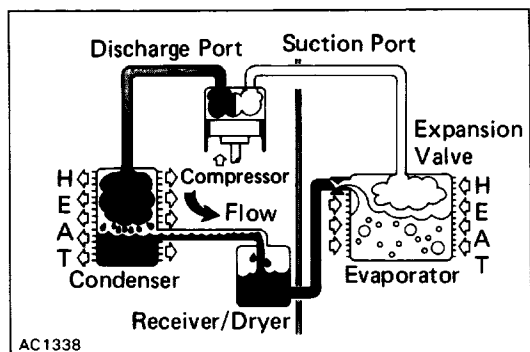

## GENERAL DESCRIPTION

### REFRIGERATION CYCLE

1. The compressor discharges high temperature and high pressure refrigerant containing the heat absorbed from the evaporator plus the heat created by the compressor in a discharge stroke.
2. This gaseous refrigerant flows into the condenser. In the condenser, the gaseous refrigerant condenses into liquid refrigerant.
3. This liquid refrigerant flows into the receiver which stores and filters the liquid refrigerant till the evaporator requires the refrigerant.
4. The liquid refrigerant is changed by the expansion valve into a low temperature, low pressure liquid and gaseous mixture.
5. This cold and foggy refrigerant flows to the evaporator. Vaporizing the liquid in the evaporator, the heat from the warm air stream passing through the evaporator core is transferred to the refrigerant. All the liquid is changed into the gaseous refrigerant in the evaporator and only heat-laden gaseous refrigerant is drawn into the compressor. Then the process is repeated again.

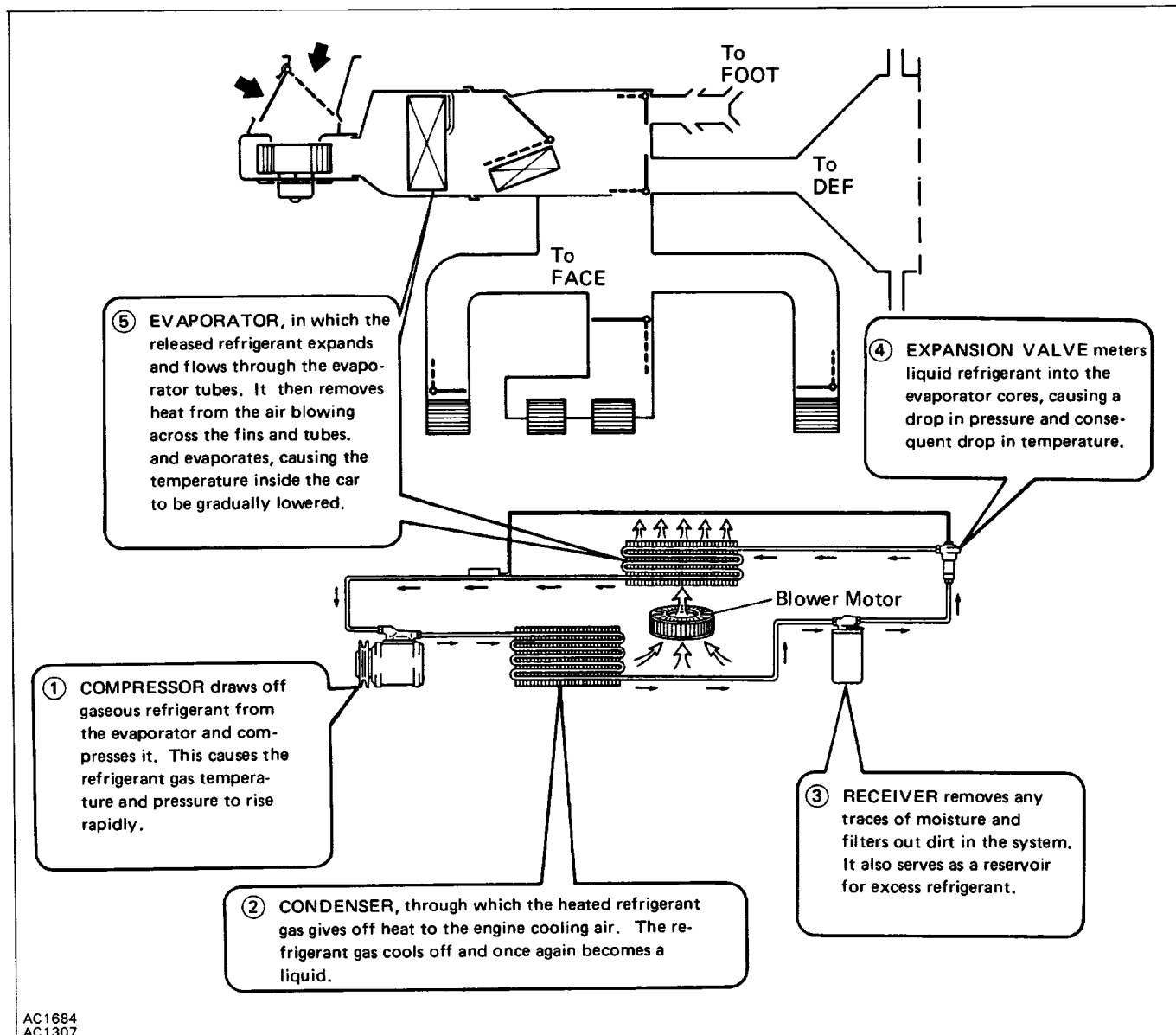

**1. PRINCIPLE OF A/C ELECTRICAL CIRCUIT**

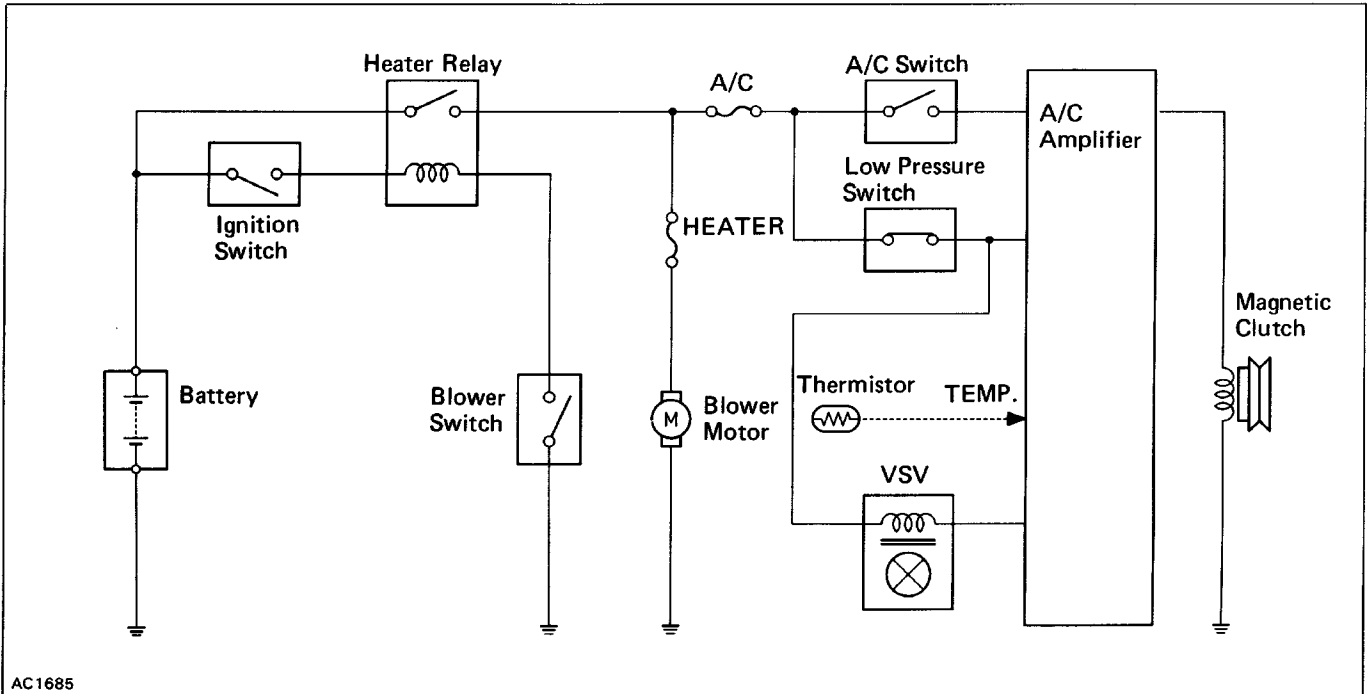

**2. HOW IS MAGNETIC CLUTCH ENERGIZED?**

The general process until the magnetic clutch is energized as shown below.

- ① Ignition Switch "ON"
- ② Blower Switch "ON" → Heater Relay "ON" (Blower Motor "RUN")
- ③ A/C Switch "ON" → A/C Amplifier "ON" (A/C Amp. Main Power Supply)
- ④ Low Pressure Switch "ON":  
Refrigerant Condition is more than 206 kPa (2.1 kgf/cm<sup>2</sup>, 30 psi)
- ⑤ Thermistor supplies temperature signal of evaporator to A/C amplifier.
- ⑥ VSV "ON" → E/G Idle-up
- ⑦ Magnetic Clutch "ON"

## SPECIAL TOOLS AND EQUIPMENT

Tool	SST No.	Use
Ohmmeter		To diagnosis electrical system
Voltage meter		To diagnosis electrical system
Air conditioning service tool set	07110-58011	To evacuate and charge system
Magnetic clutch remover	07112-66040	To remove pressure plate
Magnetic clutch stopper	07112-76060	To remove and install pressure plate
Snap ring pliers	07114-84020	To remove pressure plate

## SSM (SPECIAL SERVICE MATERIALS)

Part Name	Part No.	Use etc.
ND OIL6, SUNISO No.5GS or equivalent	07117-68040	Compressor

## TROUBLESHOOTING

Problem	Possible cause	Remedy	Page
No cooling or warm air	Magnetic clutch does not engage		
	(a) A/C fuse blown	Replace fuse and check for short	AC-6 AC-17
	(b) Magnetic clutch faulty	Check magnetic clutch	AC-29
	(c) A/C switch faulty	Check switch	AC-31
	(d) A/C amplifier faulty	Check amplifier	AC-6
	(e) Wiring or ground faulty	Repair as necessary	AC-16
	(f) Refrigerant empty	Check refrigerant volume	AC-37
	(g) Heater relay faulty	Check heater relay	AC-29
	(h) Pressure switch faulty	Check pressure switch	
	Compressor does not rotate properly		
	(a) Drive belt loose or broken	Adjust or replace drive belt	AC-15
	(b) Compressor faulty	Check compressor	AC-17
	Expansion valve faulty	Check expansion valve	AC-25
	Leak in system	Test system for leaks	
	Fusible plug on receiver blown or clogged screen	Check receiver	AC-23
Blower does not operate	(a) HEATER fuse blown	Replace fuse and check for short	AC-6 AC-29
	(b) A/C switch faulty	Check switch	AC-37
	(c) Heater relay faulty	Check heater relay	AC-37
	(d) Blower motor faulty	Check blower motor	AC-6
	(e) Wiring or ground faulty	Repair as necessary	
Cool air comes out intermittently	Magnetic clutch slipping	Check magnetic clutch	AC-17
	Expansion valve faulty	Check expansion valve	AC-25
	Wiring connection faulty	Repair as necessary	AC-6
	Excessive moisture in system	Evacuate and charge system	
	A/C amplifier faulty	Check amplifier	AC-31

## TROUBLESHOOTING (Cont'd)

Problem	Possible cause	Remedy	Page
Cool air comes out only at high speed	Condenser clogged Drive belt slipping Compressor faulty Insufficient or too much refrigerant Air in system	Check condenser Check or replace drive belt Check compressor Check refrigerant volume Evacuate and charge system	<a href="#">AC-24</a> <a href="#">AC-15</a> <a href="#">AC-17</a> <a href="#">AC-16</a>
Insufficient cooling	Condenser clogged Drive belt slipping Magnetic clutch faulty Compressor faulty Expansion valve faulty Insufficient *or too much refrigerant Air or excessive compressor oil in system Receiver clogged Water valve cable faulty A/C amplifier faulty	Check condenser Check or replace drive belt Check magnetic clutch Check compressor Check expansion valve Check refrigerant volume Evacuate and charge system Check receiver Reset water valve cable Check amplifier	<a href="#">AC-24</a> <a href="#">AC-15</a> <a href="#">AC-17</a> <a href="#">AC-17</a> <a href="#">AC-25</a> <a href="#">AC-16</a>  <a href="#">AC-23</a> <a href="#">AC-36</a> <a href="#">AC-31</a>
Insufficient velocity of cool air	Evaporator clogged or frosted Air leakage from cooling unit or air duct Air inlet blocked Blower motor faulty A/C amplifier faulty	Clean evaporator fins or filters Repair as necessary Repair as necessary Check blower motor Check amplifier	<a href="#">AC-27</a>   <a href="#">AC-37</a> <a href="#">AC-31</a>



## Inspection of Refrigeration System with Manifold Gauge Set

This is a method in which the trouble is located by using a manifold gauge set. (See "Installation of Manifold Gauge Set" on page AC-16. ) Read the manifold gauge pressure when the following conditions are established:

- (b) Engine running at 2,000 rpm
- (a) Temperature at the air inlet with the switch set at RECIRC is 30 – 35°C (86 – 95°F)
- (c) Blower fan speed control switch set at high speed
- (d) Temperature control switch set at max. cool side

HINT: It should be noted that the gauge indications may vary slightly due to ambient temperature conditions.

### NOTICE:

- Always recover refrigerant before removing the parts in the refrigerant line and evacuating air.
- Evacuate air and charge proper amount of purified refrigerant after installing the parts in the refrigerant line.

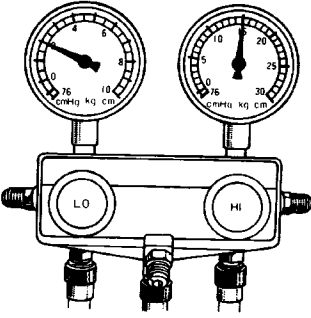
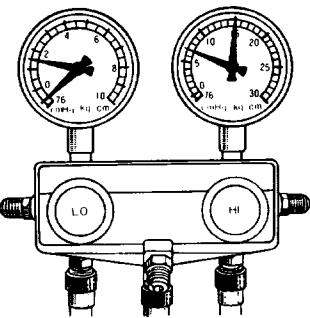
No.	Gauge reading kPa (kgf/cm <sup>2</sup> , psi)	Condition	Probable cause	Remedy
1	LO: 147 – 196 (1.5 – 2.0, 21 – 28) HI: 1,422 – 1,471 (14.5 – 15.0, 206 – 213)    AC0067	Normal cooling	Normally functioning system	
2	During operation, pressure at low pressure side sometimes becomes a vacuum and sometimes normal    AC0068	Periodically cools and then fails to cool	Moisture present in refrigeration system	(1) Replace receiver (2) Remove moisture in system through repeatedly evacuating air

**NOTICE:**

- Always recover refrigerant before removing the parts in the refrigerant line and evacuating air.
- Evacuate air and charge proper amount of purified refrigerant after installing the parts in the refrigerant line.

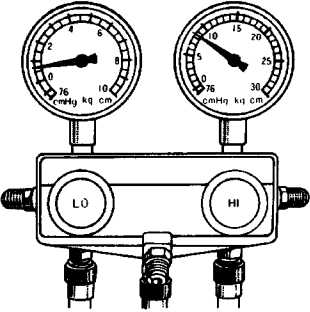
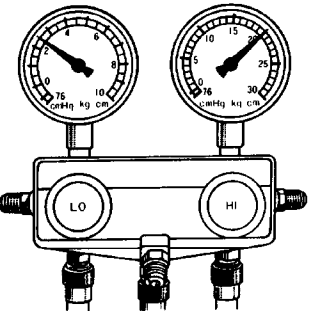
No.	Gauge reading kPa (kgf/cm <sup>2</sup> , psi)	Condition	Probable cause	Remedy
3	<b>Pressure low at both low and high pressure sides</b>  AC0069	<ul style="list-style-type: none"> <li>• Insufficient cooling</li> <li>• Bubbles seen in sight glass</li> </ul>	Insufficient refrigerant	(1) Check for gas leakage with gas leak tester and repair if necessary (2) Add refrigerant until bubbles disappear
		<ul style="list-style-type: none"> <li>• Insufficient cooling</li> <li>• Frost on tubes from receiver to unit</li> </ul>	Refrigerant flow obstructed by dirt in receiver	Replace receiver
4	<b>Pressure too high at both low and high pressure sides</b>  AC0070	Insufficient cooling	Insufficient cooling of condenser	(1) Clean condenser (2) Check fan motor operation
5			Refrigerant over-charged	(1) Check amount of refrigerant If refrigerant is over-charged (2) Recover refrigerant (3) Evacuate air and charge proper amount of purified refrigerant
6			Air present in system	(1) Replace receiver (2) Check compressor oil to see if dirty (3) Remove air in system through repeatedly evacuating air
7			<ul style="list-style-type: none"> <li>• Insufficient cooling</li> <li>• Frost or Large amount of dew on piping at low pressure side</li> </ul>	Expansion valve improperly mounted, heat sensing tube defective (Opens too wide)

**Hint at 6:**

These gauge indications are for when the refrigeration system has been opened and the refrigerant charged without evacuating air.

**NOTICE:**

- Always recover refrigerant before removing the parts in the refrigerant line and evacuating air.
- Evacuate air and charge proper amount of purified refrigerant after installing the parts in the refrigerant line.

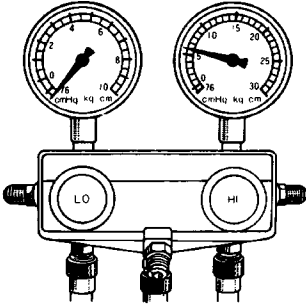
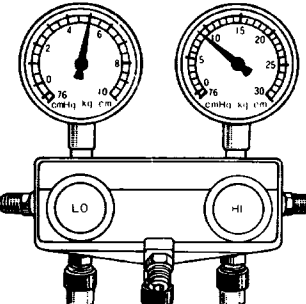
No.	Gauge reading kPa (kgf/cm <sup>2</sup> , psi)	Condition	Probable cause	Remedy
8	<p>Vacuum indicated at low pressure side, very low pressure indicated at high pressure</p>  <p style="text-align: right;">AC0156</p>	<ul style="list-style-type: none"> <li>• Does not cool (Cools from time to time in some cases)</li> <li>• Frost or dew seen on piping before and after receiver or expansion valve</li> </ul>	Refrigerant does not circulate	<p>(1) Check heat sensing tube for gas leakage and replace expansion valve if defective If (1) is normal (2) Clean out dirt in expansion valve by blowing with air If not able to remove dirt, replace expansion valve (3) Replace receiver</p>
9	<p>Pressure too high at low pressure side, pressure too low at high pressure side</p>  <p style="text-align: right;">AC0157</p>	Does not cool	Insufficient compression	Repair or replace compressor

# ON-VEHICLE INSPECTION

## 7. CHECK CONDENSER FINS FOR BLOCKAGE OR DAMAGE

If the fins are clogged, clean them with pressurized water.

**NOTICE:** Be careful not to damage the fins.

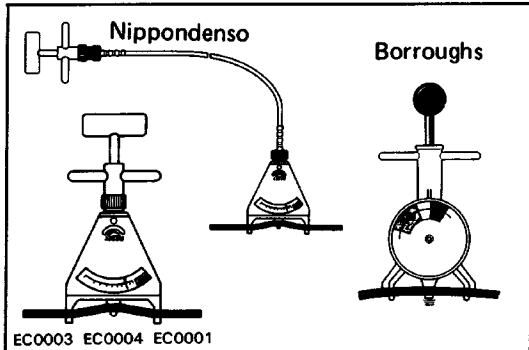

## 2. CHECK DRIVE BELT TENSION

Using a belt tension gauge, check the drive belt tension.

**Belt tension gauge:**

**Nippondenso** BTG-20 (95506-00020) or

**Borroughs No.** BT-33-73F

**Drive belt tension:**

	New belt (lbs)	Used belt (lbs)
3VZ	125 ± 25	80 ± 20
22R-E	125 ± 25	80 ± 20

**HINT:**

- "New belt" refers to a belt which has been used less than 5 minutes on a running engine.
- "Used belt" refers to a belt which has been used on a running engine for 5 minutes or more.

## 3. START ENGINE

### 4. TURN ON A/C SWITCH

Check that the A/C operates at each position of the blower switch.

If blower does not operate, check heater fuse.

## 5. CHECK MAGNETIC CLUTCH OPERATION

### 6. CHECK THAT IDLE INCREASES

When the magnetic clutch engages, engine revolution should increase.

**Standard idle-up rpm: 900 – 1,000 rpm**

## 7. CHECK AMOUNT OF REFRIGERANT

If you can see bubbles in the sight glass, additional refrigerant is needed. (See page AC-16)

## 8. IF NO COOLING OR IT IS INSUFFICIENT, INSPECT FOR LEAKAGE

Using a gas leak tester, inspect each component of the refrigeration system.

## REFRIGERATION SYSTEM

### Checking of Refrigerant Volume

1. RUN ENGINE AT APPROX. 1,500 RPM
2. OPERATE AIR CONDITIONING AT MAXIMUM COOLING FOR A FEW MINUTES
3. CHECK AMOUNT OF REFRIGERANT  
Observe the sight glass on the receiver.

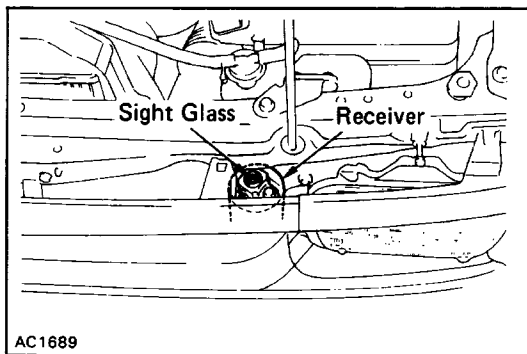

Item	Symptom	Amount of refrigerant	Remedy
1	Bubbles present in sight glass	Insufficient *	(1) Check for gas leakage with gas leak tester and repair if necessary (2) Add refrigerant until bubbles disappear
2	No bubbles present in sight glass	None, sufficient or too much	Refer to items 3 and 4
3	No temperature difference between compressor inlet and outlet	Empty or nearly empty	(1) Check for gas leakage with gas leak tester and repair if necessary (2) Add refrigerant until bubbles disappear
4	Temperature between compressor inlet and outlet is noticeably different	Proper or too much	Refer to items 5 and 6
5	Immediately after air conditioning is turned off, refrigerant in sight glass stays clear	Too much	(1) Recover refrigerant (2) Evacuate air and charge proper amount of purified refrigerant
6	When air conditioning is turned off, refrigerant foams and then stay clear	Proper	—

\*: Bubbles in the sight glass with ambient temperatures higher can be considered normal if cooling is sufficient

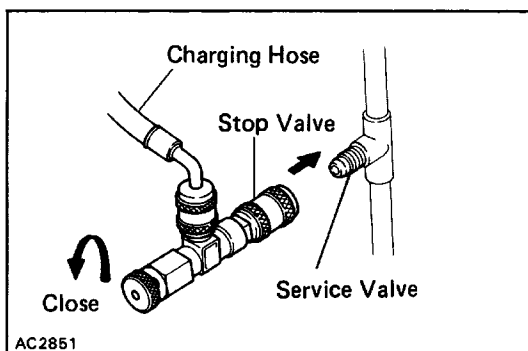

## Installation of Manifold Gauge Set

HINT: To prevent releasing refrigerant, use charging hoses with a stop valve when installing the manifold gauge set to service valves on the refrigerant line.

Part No. of charging hoses with a stop valve

### 1. CONNECT CHARGING HOSES WITH A STOP VALVE TO MANIFOLD GAUGE SET

Tighten the nuts by hand.

#### CAUTION:

- Do not connect the wrong hoses to the high pressure and the low pressure sides.
- To prevent loosening the nuts, do not apply compressor oil to seat of the connection.

### 2. CLOSE HAND VALVES OF BOTH STOP VALVES

### 3. CLOSE BOTH HAND VALVES OF GAUGE SET

### 4. REMOVE CAPS FROM SERVICE VALVES ON REFRIGERANT LINE

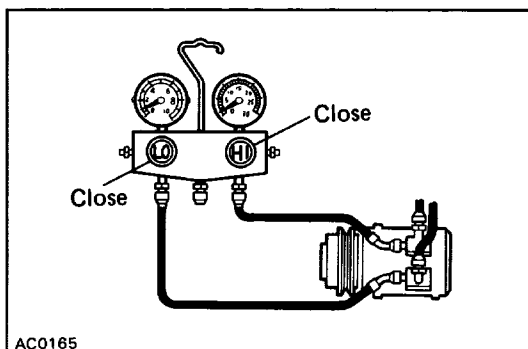

**5. CONNECT STOP VALVES TO SERVICE VALVES**

Tighten the nuts by hand.

**CAUTION:**

- Do not connect the wrong valves to the high pressure and the low pressure sides.
- To prevent loosening the nuts, do not apply compressor oil to seat of the connection.

**6. OPEN HAND VALVES OF BOTH STOP VALVES****REMOVAL OF MANIFOLD GAUGE SET****1. CLOSE BOTH HAND VALVES OF MANIFOLD GAUGE SET****2. CLOSE HAND VALVES OF BOTH STOP VALVES****3. DISCONNECT STOP VALVES FROM SERVICE VALVES ON REFRIGERANT LINE****4. INSTALL CAPS TO SERVICE VALVES**

## COMPRESSOR

### ON-VEHICLE INSPECTION

**1. INSTALL MANIFOLD GAUGE SET**

(See page [AC-16](#))

**2. RUN ENGINE AT APPROX. 1,500 RPM****3. CHECK COMPRESSOR FOR FOLLOWING:**

- High pressure gauge reading is not low and low pressure gauge reading is not higher than normal.
  - Metallic sound
  - Leakage from shaft seal
- If defects are found, repair the compressor.

**4. CHECK MAGNETIC CLUTCH**

- Inspect the pressure plate and the rotor for signs of oil.
- Check the clutch bearings for noise and grease leakage.
- Using an ohmmeter, measure the resistance of the stator coil between the clutch lead wire and ground.

**Standard resistance:  $3.6 \pm 0.2 \Omega$  at 200C (680F)**

If resistance value is not as specified, replace the coil.

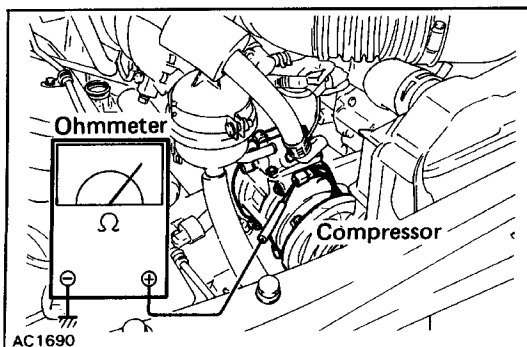

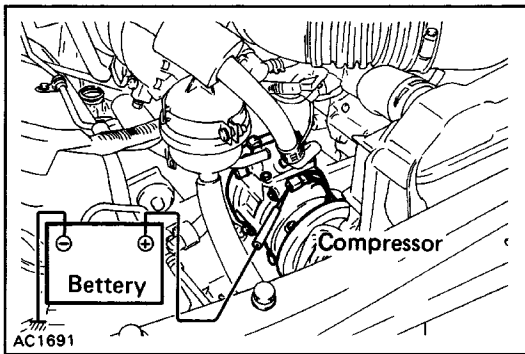

- (d) Connect the positive (+) lead from the battery to terminal and the negative (-) lead to ground, check that the magnetic clutch is energized. If magnetic clutch is not energized, replace the coil.  
**NOTICE:** Do not short the positive (+) lead wire on the vehicle by applying battery positive voltage.

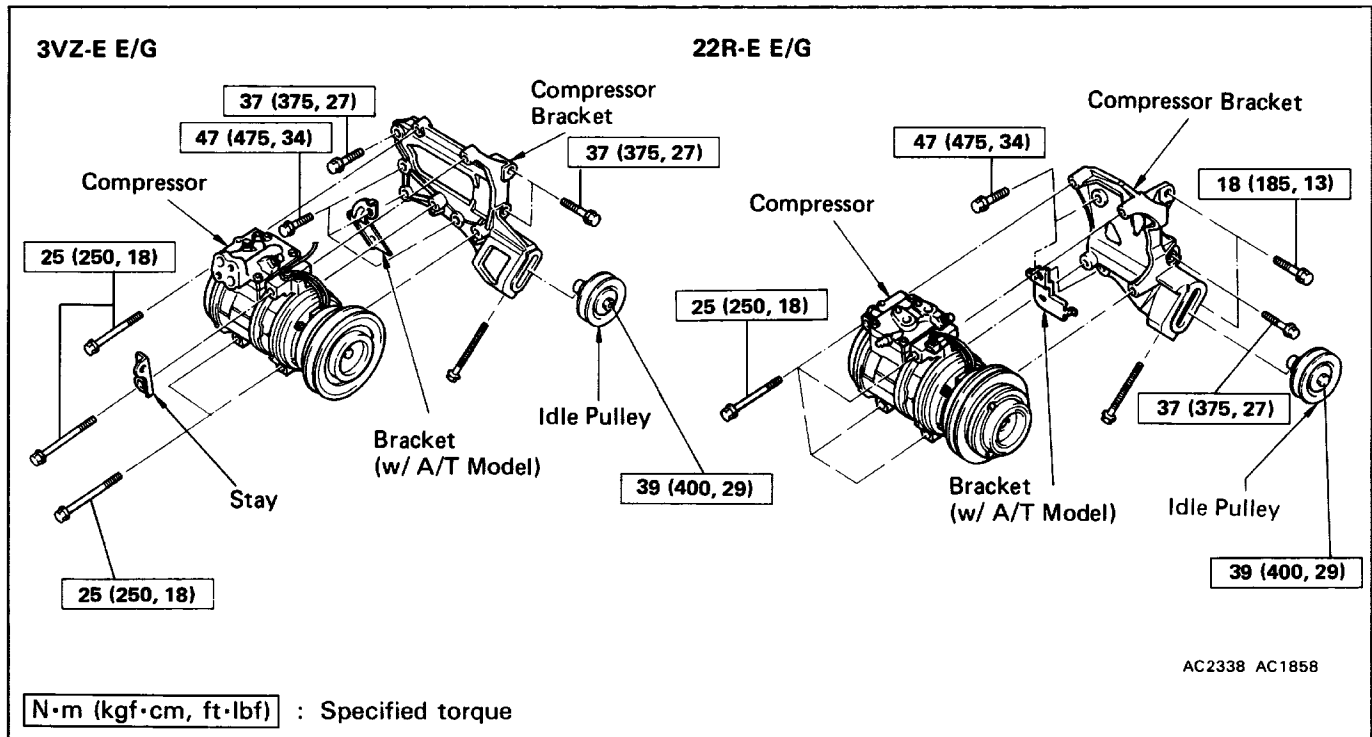

### REMOVAL OF COMPRESSOR

1. RUN ENGINE AT IDLE SPEED FOR 10 MINUTES WITH AIR CONDITIONING ON
2. STOP ENGINE
3. DISCONNECT NEGATIVE CABLE FROM BATTERY
4. REMOVE POWER STEERING PUMP (3VZ EG ONLY)
5. DISCONNECT CLUTCH LEAD WIRE FROM WIRING HARNESS
6. RECOVER REFRIGERANT FROM REFRIGERATION SYSTEM
7. DISCONNECT TWO HOSES FROM COMPRESSOR SERVICE VALVES  
 Cap the open fitting immediately to keep moisture out of the system.
8. REMOVE COMPRESSOR
  - (a) Remove the fan shroud.
  - (b) Loosen the drive belt.
  - (c) Remove the compressor mounting bolts and the compressor.

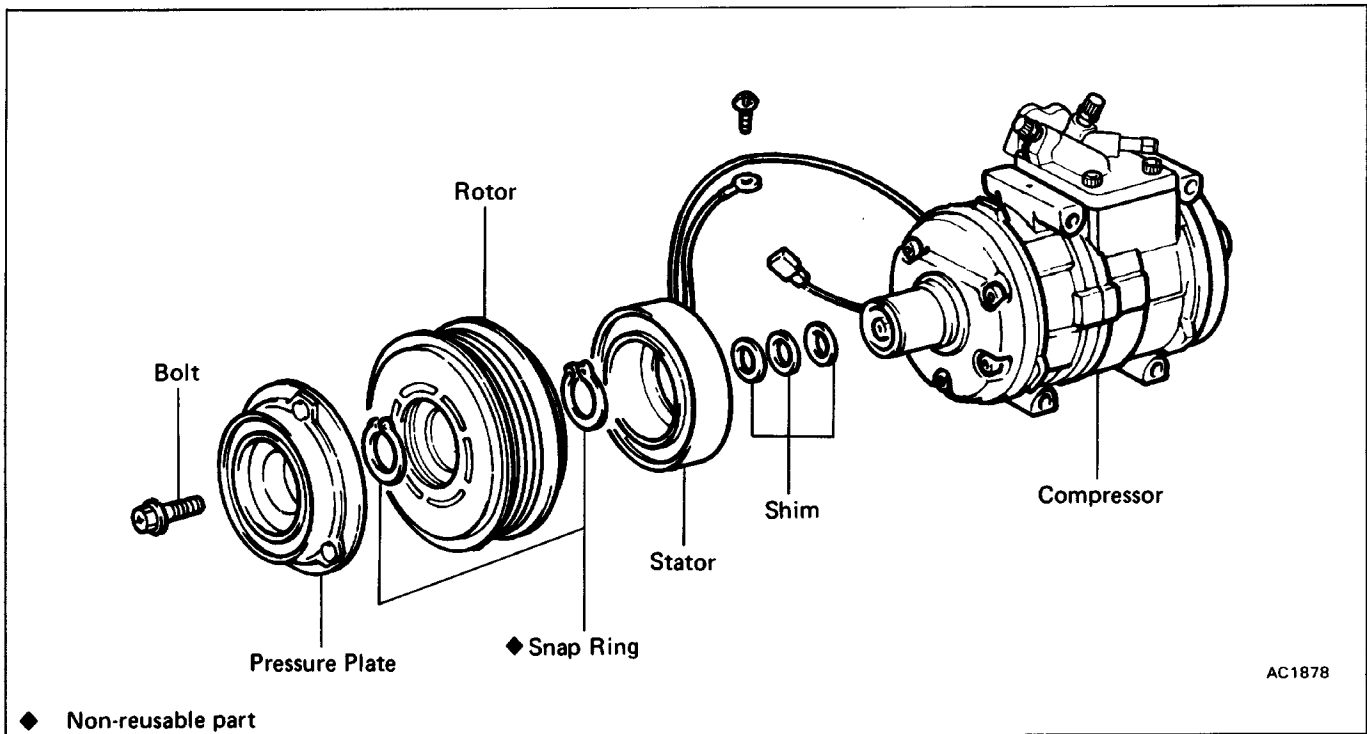

**DISASSEMBLY OF MAGNETIC CLUTCH**

**1. REMOVE PRESSURE PLATE**

(a) Using SST and a socket, remove the shaft bolt.  
SST 07112-76060

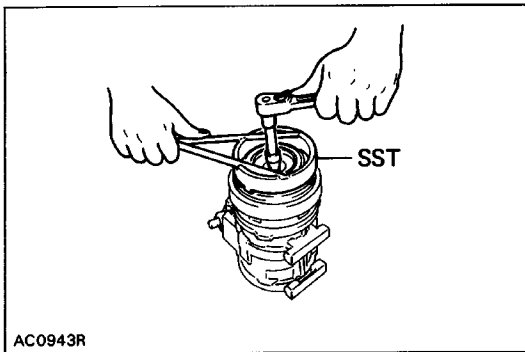

(b) Install SST to the pressure plate.  
SST 07112-66040

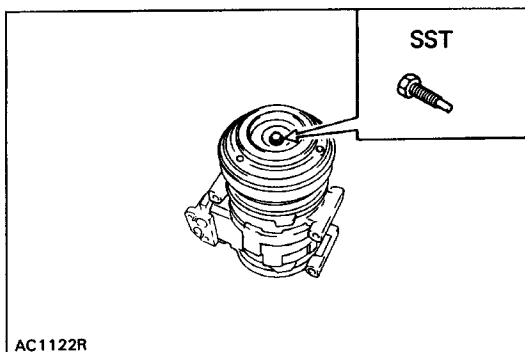

(c) Using SST and a socket, remove the pressure plate. SST 07112-76060

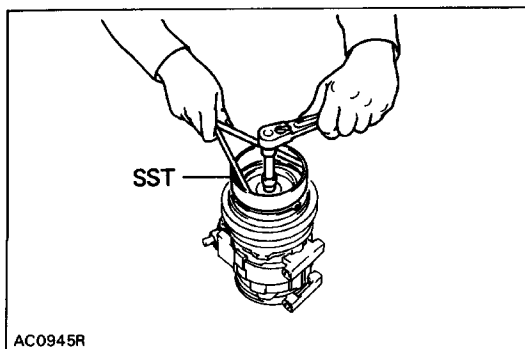



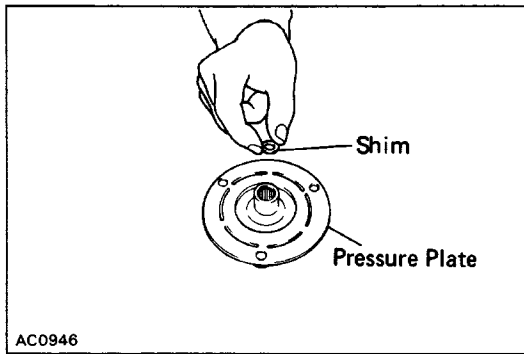

- (d) Remove the shims from the pressure plate.

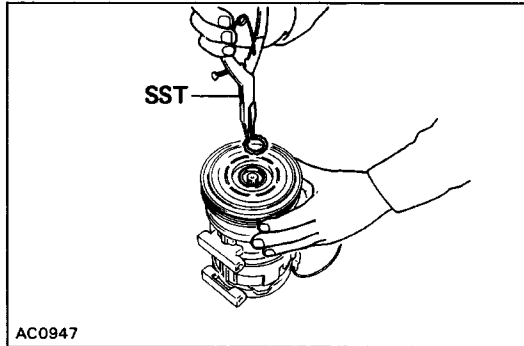

## 2. REMOVE ROTOR

- (a) Using SST, remove the snap ring.  
SST 07114-84020

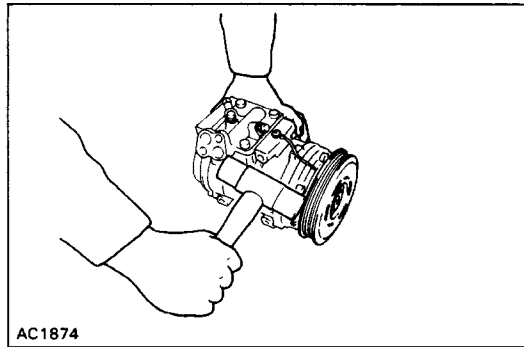

- (b) Using a plastic hammer, tap the rotor off the shaft.

**NOTICE:** Be careful not to damage the pulley when tapping on the rotor.

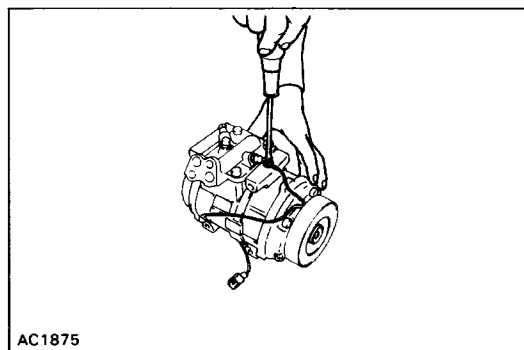

## 3. REMOVE STATOR

- (a) Disconnect the stator lead wire from the compressor housing.

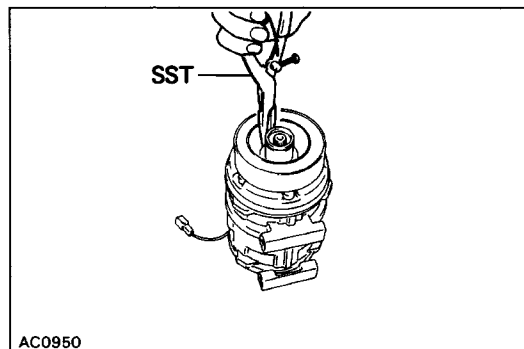

- (b) Using SST, remove the snap ring.  
SST 07114-84020

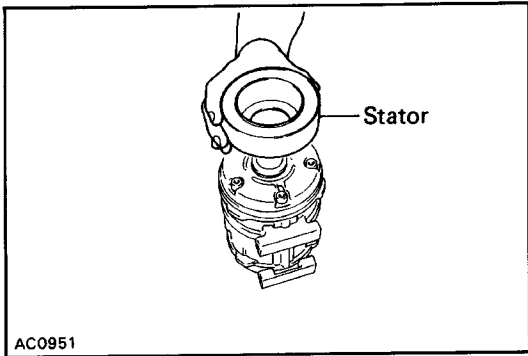

(c) Remove the stator.

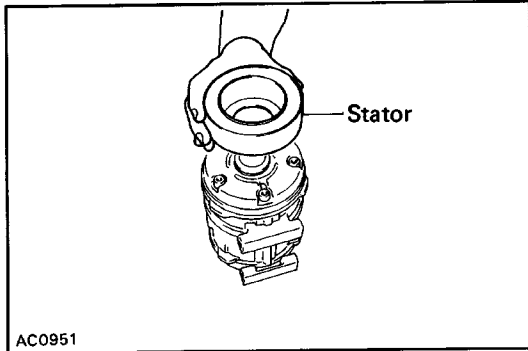

## ASSEMBLY OF MAGNETIC CLUTCH

### 1. INSTALL STATOR

(a) Install the stator on the compressor.

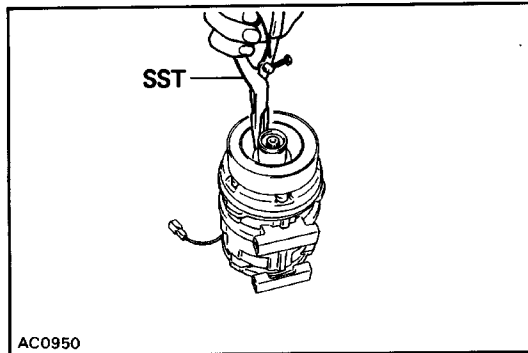

(b) Using SST, install the new snap ring.  
SST 07114-84020

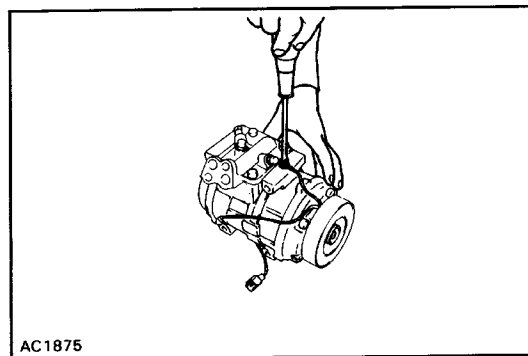

(c) Connect the stator lead wires to the compressor housing.

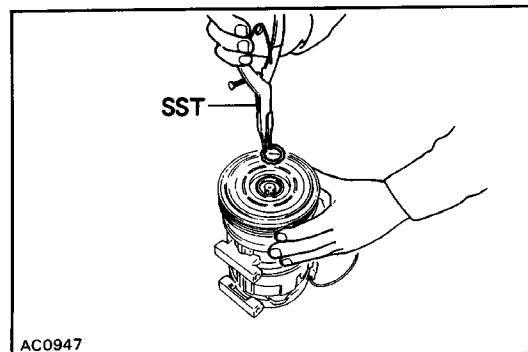

### 2. INSTALL ROTOR

(a) Install the rotor on the compressor shaft.

(b) Using SST, install the snap ring.  
SST 07114-84020

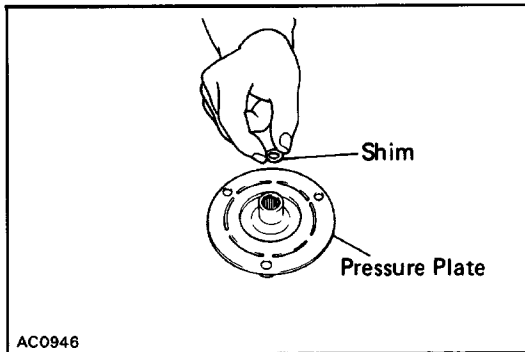

### 3. INSTALL PRESSURE PLATE

- (a) Put the shims to the pressure plate.

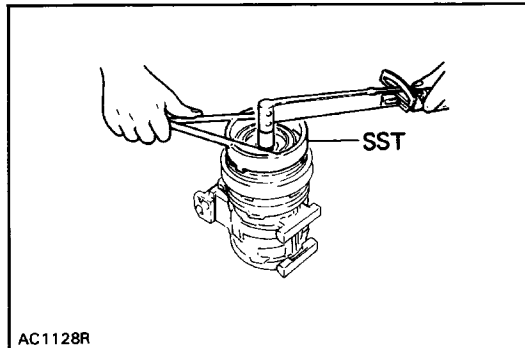

- (b) Using SST and torque wrench, install the shaft bolt. SST 07112-76060

Torque: 14 N·m (140 kgf·cm, 10 ft·lbf)

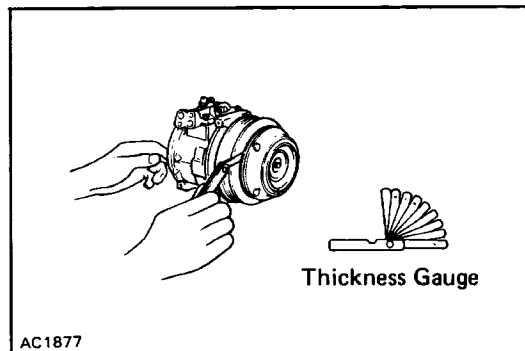

### 4. CHECK CLEARANCE OF MAGNETIC CLUTCH

Check the clearance between the pressure plate and rotor using thickness gauge.

**Standard clearance:**

$0.5 \pm 0.15$  mm (0.020 i 0.0059 in.)

If the clearance is not within tolerance, change the number of shims to obtain the standard clearance.

## INSTALLATION OF COMPRESSOR

(See page [AC-17](#) )

### 1. INSTALL COMPRESSOR WITH THREE MOUNTING BOLTS

Torque: 27 N·m (280 kgf·cm, 20 ft·lbf )

### 2. INSTALL DRIVE BELT

(See step 2 and 3 and on page [AC-14](#))

### 3. CONNECT TWO HOSES TO COMPRESSOR SERVICE VALVES

Torque: Discharge line 25 N·m (250 kgf·cm, 18 ft·lbf )

Suction line 25 N·m (250 kgf·cm, 18 ft·lbf)

### 4. CONNECT CLUTCH LEAD WIRE TO WIRING HARNESS

### 5. CONNECT NEGATIVE CABLE TO BATTERY

### 6. EVACUATE AIR FROM AIR CONDITIONING SYSTEM

### 7. CHARGE AIR CONDITIONING SYSTEM WITH

REFRIGERANT AND CHECK FOR GAS LEAKAGE

Specified amount: 700 – 800 g (1.5 – 1.8 lb)

## RECEIVER

(See page [AC-7](#))

### ON-VEHICLE INSPECTION

CHECK SIGHT GLASS, FUSIBLE PLUG AND FITTINGS FOR LEAKAGE

Use a gas leak tester. Repair as necessary.

### REMOVAL OF RECEIVER

1. RECOVER REFRIGERANT FROM REFRIGERATION SYSTEM
2. DISCONNECT TWO LIQUID TUBES FROM RECEIVER  
HINT: Cap the open fittings immediately to keep moisture out of the system.
3. REMOVE RECEIVER FROM RECEIVER HOLDER

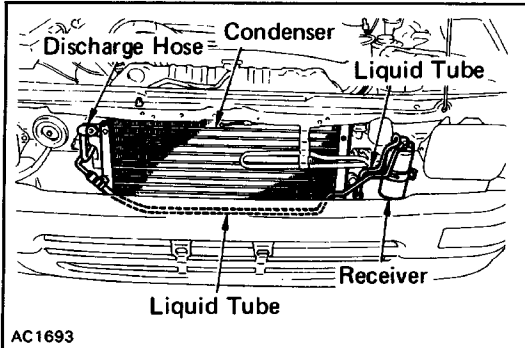

### INSTALLATION OF RECEIVER

1. INSTALL RECEIVER IN RECEIVER HOLDER  
HINT: Do not remove the caps until ready for connection.
2. CONNECT TWO LIQUID TUBES TO RECEIVER  
Torque: 5.4 N·m (55 kgf·cm, 43 in.·lbf)
3. IF RECEIVER WAS REPLACED, ADD COMPRESSOR OIL TO COMPRESSOR  
Add 20 cc (0.7 fl. oz.)  
Compressor oil: ND OIL6,  
SUNISO No.5GS or equivalent
4. EVACUATE AIR FROM AIR CONDITIONING SYSTEM
5. CHARGE AIR CONDITIONING SYSTEM WITH REFRIGERANT AND CHECK FOR GAS LEAKAGE  
Specified amount: 700 – 800 g (1.5 – 1.8 lb)

# CONDENSER

## ON-VEHICLE INSPECTION

### 1. CHECK CONDENSER FINS FOR BLOCKAGE OR DAMAGE

If the fins are clogged, wash them with water and dry with compressed air.

**NOTICE:** Be careful not to damage the fins.

If the fins are bent, straighten them with a screwdriver or pliers.

### 2. CHECK CONDENSER FITTINGS FOR LEAKAGE

Repair as necessary.

## REMOVAL OF CONDENSER

(SEE PAGE [AC-7](#))

### 1. RECOVER REFRIGERANT FROM REFRIGERATION SYSTEM

### 2. REMOVE FRONT GRILLE AND HOOD LOCK BRACE

### 3. DISCONNECT DISCHARGE HOSE FROM CONDENSER INLET FITTING

### 4. DISCONNECT LIQUID TUBE FROM RECEIVER OUTLET FITTING

**HINT:** Cap the open fittings immediately to keep moisture out of the system.

### 5. REMOVE CONDENSER

Remove the four bolts.

## INSTALLATION OF CONDENSER

(SEE PAGE [AC-7](#))

### 1. INSTALL CONDENSER

Install the four bolts making sure the rubber cushions fit on the mounting flanges correctly.

### 2. CONNECT LIQUID TUBE TO RECEIVER AND DISCHARGE HOSE TO CONDENSER

Torque:

Liquid tube 5.4 N·m (55 kgf·cm, 48 in.·lbf)

Discharge hose 18.5 N·m (185 kgf·cm, 14 ft·lbf)

### 3. INSTALL FRONT GRILLE AND HOOD LOCK BRACE

### 4. IF CONDENSER IS REPLACED, ADD COMPRESSOR OIL TO COMPRESSOR

Add 40 – 50 cc (1.4 – 1.7 fl.oz.)

Compressor oil: ND OIL6,

SUNISO No.5GS or equivalent

### 5. EVACUATE AIR FROM AIR CONDITIONING SYSTEM

### 6. CHARGE AIR CONDITIONING SYSTEM WITH REFRIGERANT AND CHECK FOR GAS LEAKAGE

Specified amount: 700 – 800 g (1.5 – 1.8 lb)

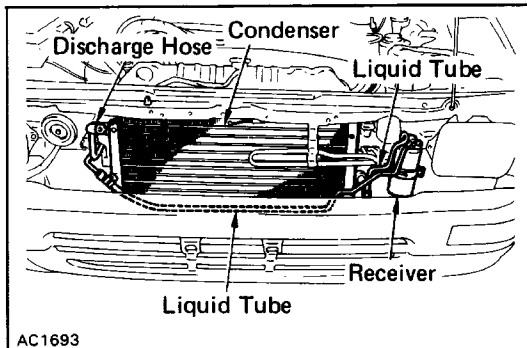

## COOLING UNIT

(SEE PAGE AC-7)

### ON-VEHICLE INSPECTION OF EXPANSION VALVE

1. CHECK QUANTITY OF REFRIGERANT GAS DURING REFRIGERATION CYCLE
2. INSTALL MANIFOLD GAUGE SET  
(See page AC-16)
3. RUN ENGINE

Run the engine at 2,000 rpm for at least 5 minutes.

4. CHECK EXPANSION VALVE

If the expansion valve is clogged, the low pressure reading will drop to 0 kPa (0 kgf/cm<sup>2</sup>, 0 psi) otherwise it is OK.

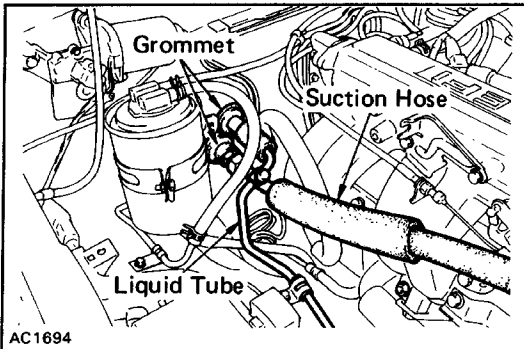
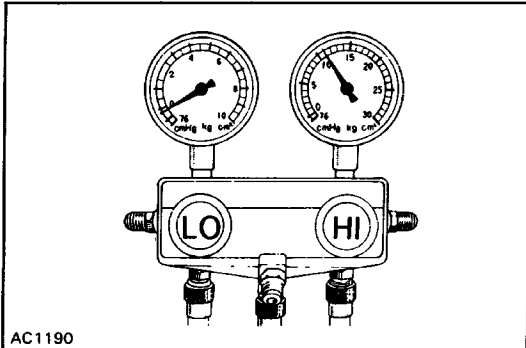

### REMOVAL OF COOLING UNIT

1. DISCONNECT NEGATIVE CABLE FROM BATTERY
2. RECOVER REFRIGERANT FROM REFRIGERATION SYSTEM
3. DISCONNECT SUCTION TUBE FROM COOLING UNIT OUTLET FITTING
4. DISCONNECT LIQUID TUBE FROM COOLING UNIT INLET FITTING

HINT: Cap the open fittings immediately to keep moisture out of the system.

5. REMOVE GROMMETS FROM INLET AND OUTLET FITTINGS
6. REMOVE GLOVE BOX
7. DISCONNECT CONNECTOR
8. REMOVE COOLING UNIT

Remove the five screws and a nut.

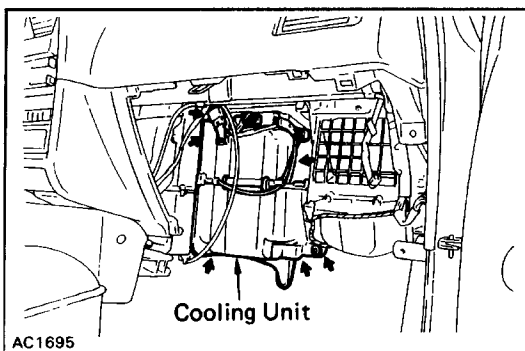

## DISASSEMBLY OF COOLING UNIT

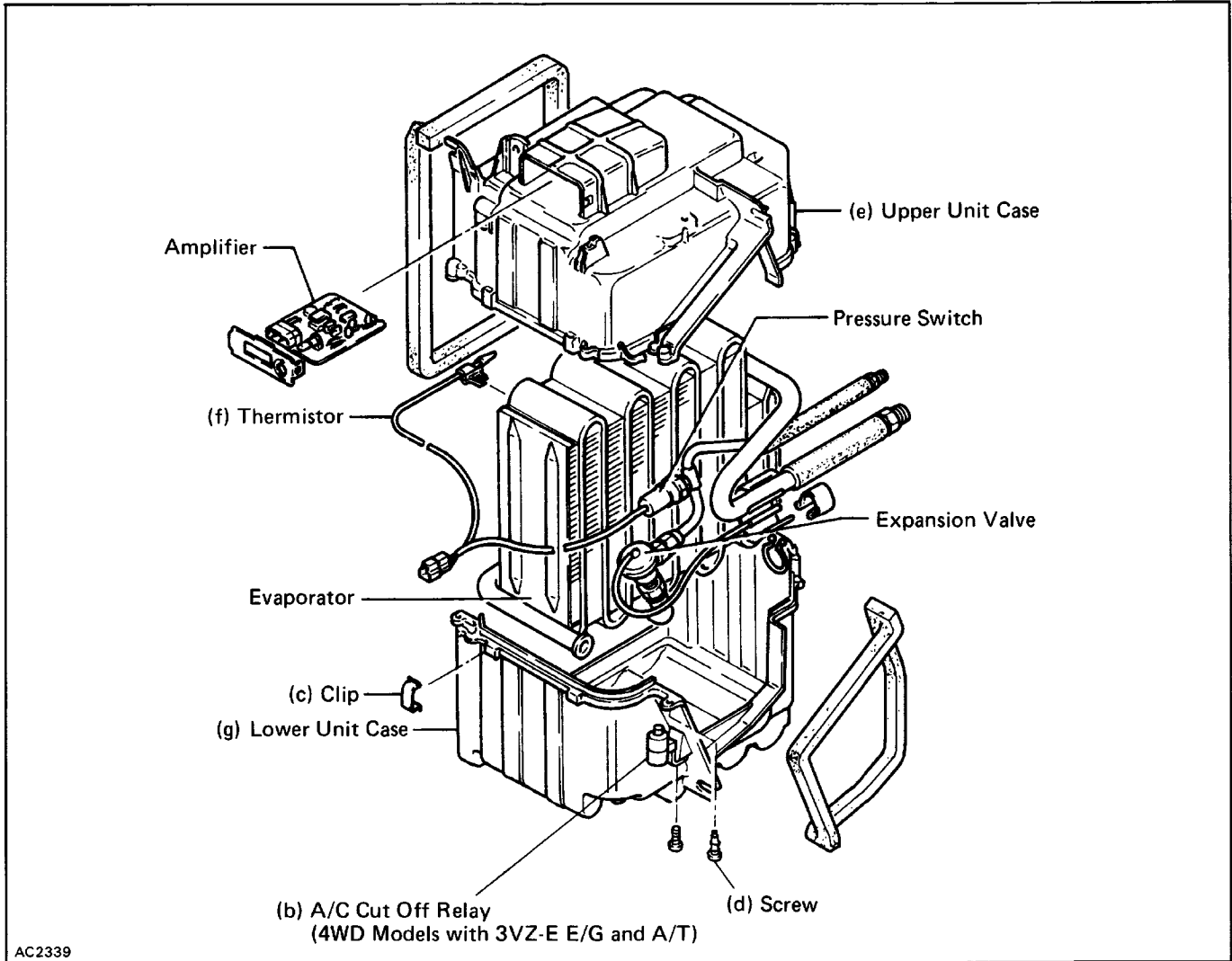

### 1. REMOVE LOWER AND UPPER UNIT CASES

- Disconnect connector.
- Remove A/C cut off relay (4WD with 3VZ-E E/G and A/T)
- Remove four clips.
- Remove four screws.
- Remove upper unit case.
- Remove thermistor with thermistor holder.
- Remove lower unit case.

### 2. REMOVE EXPANSION VALVE

- Disconnect the liquid tube from the inlet fitting of the expansion valve.
- Remove the packing and heat sensing tube from suction tube of evaporator.

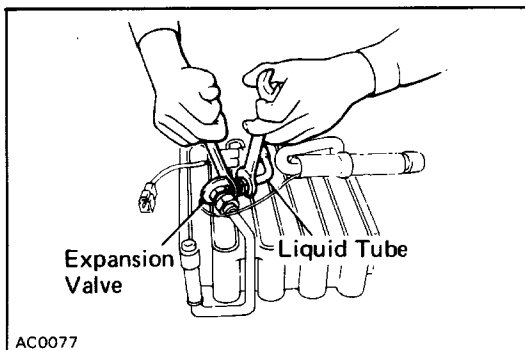

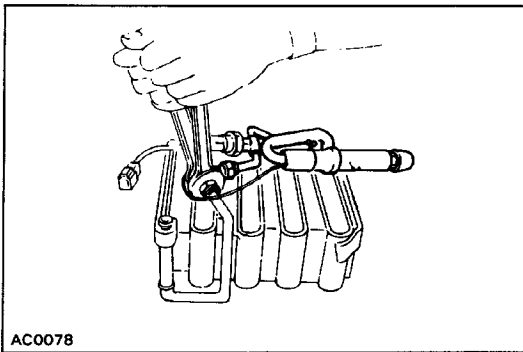

(c) Remove expansion valve.

## Evaporator

### INSPECTION OF EVAPORATOR

#### 1. CHECK EVAPORATOR FINS FOR BLOCKAGE

If the fins are clogged, clean them with compressed air.

**NOTICE:** Never use water to clean the evaporator.

#### 2. CHECK FITTINGS FOR CRACKS OR SCRATCHES

Repair as necessary.

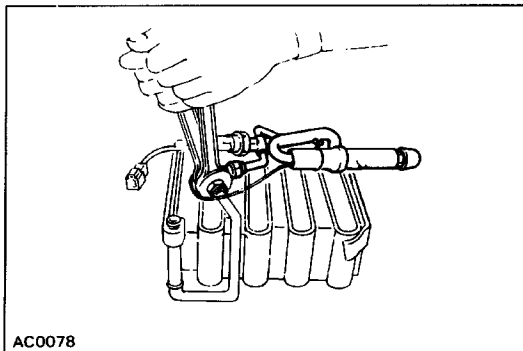

## ASSEMBLY OF COOLING UNIT

### INSTALL COMPONENTS ON EVAPORATOR

(a) Connect the expansion valve to the inlet fitting of the evaporator. Torque the nut.

**Torque:** 23 N·m (235 kgf·cm, 17 ft·lbf)

**HINT:** Be sure that the O-rings are positioned on the tube fitting.

(b) Install the holder to the suction tube with heat sensitizing tube.

(c) Connect the liquid tube to the inlet fitting of the expansion valve. Torque the nut.

**Torque:** 13 N·m (135 kgf·cm, 10 ft·lbf)

(d) Install lower unit case to the evaporator.

(e) Install thermistor to the evaporator.

(f) Install upper unit case

(g) Install four screws.

(h) Install four clips.

(i) Install A/C cut off relay.

(j) Connect connectors.

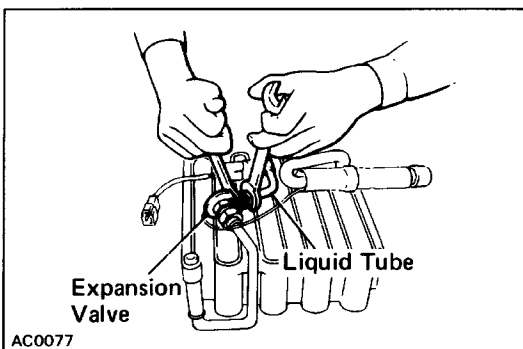

## INSTALLATION OF COOLING UNIT

### 1. INSTALL COOLING UNIT

Install the cooling unit with four screws and a bolt.

### 2. CONNECT CONNECTOR

### 3. INSTALL GLOVE BOX AND REINFORCEMENT



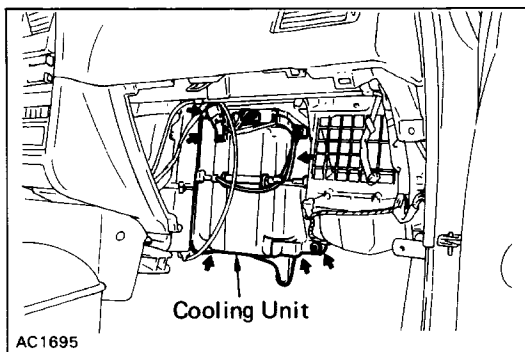

AC1695

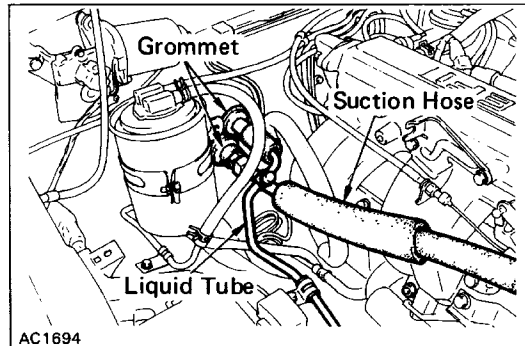

AC1694

**4. INSTALL GROMMETS ON INLET AND OUTLET FITTINGS****5. CONNECT LIQUID TUBE TO COOLING UNIT INLET FITTING**

Torque: 13 N·m (135 kgf·cm, 10 ft·lbf)

**6. CONNECT SUCTION TUBE TO COOLING UNIT OUTLET FITTING**

Torque: 32 N·m (325 kgf·cm, 24 ft·lbf)

**7. IF EVAPORATOR WAS REPLACED, ADD COMPRESSOR OIL TO COMPRESSOR**

Add 40 – 50 cc (1.4 – 1.7 fl.oz.)

Compressor oil: ND OIL6,

SUNISO No.5GS or equivalent

**8. CONNECT NEGATIVE CABLE TO BATTERY****9. EVACUATE AIR FROM AIR CONDITIONING SYSTEM****10. CHARGE AIR CONDITIONING SYSTEM WITH REFRIGERANT AND CHECK FOR GAS LEAKAGE**

Specified amount: 700 – 800 g (1.5 – 1.8 lb)

**REFRIGERANT LINES****ON-VEHICLE INSPECTION****1. INSPECT HOSES AND TUBES FOR LEAKAGE**

Use a gas leak tester. Replace, if necessary.

**2. CHECK THAT HOSE AND TUBE CLAMPS ARE NOT LOOSE**

Tighten or replace, as necessary.

**REPLACEMENT OF REFRIGERANT LINES**

(SEE PAGE [AC-7](#))

**1. RECOVER REFRIGERANT FROM REFRIGERATION SYSTEM****2. REPLACE FAULTY TUBE OR HOSE**

HINT: Cap the open fittings immediately to keep moisture out of the system.

**3. TIGHTENING TORQUE FOR O-RING FITTINGS AND BOLTED TYPE FITTINGS (See page [AC-7](#))****4. EVACUATE AIR FROM AIR CONDITIONING SYSTEM****5. CHARGE AIR CONDITIONING SYSTEM WITH REFRIGERANT AND CHECK FOR GAS LEAKAGE**

Specified amount: 700 – 800 g (1.5 – 1.8 lb)

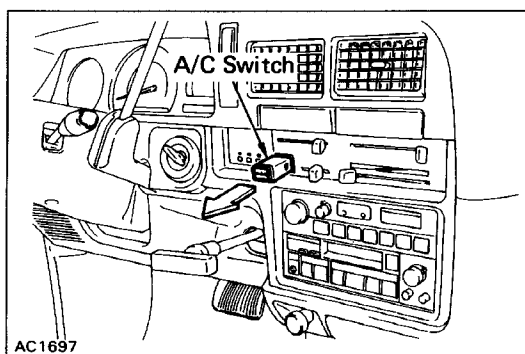

AC1697

## AC SWITCH

### ON-VEHICLE INSPECTION

1. DISCONNECT NEGATIVE CABLE FROM BATTERY
2. REMOVE GLOVE BOX
3. REMOVE A/C SWITCH
4. CHECK A/C SWITCH FOR CONTINUITY

Using an ohmmeter, check for continuity between the terminals for each switch position shown in the table.

If there is no continuity, replace the A/C switch.

5. INSTALL A/C SWITCH
6. INSTALL GLOVE BOX
7. CONNECT NEGATIVE CABLE TO BATTERY

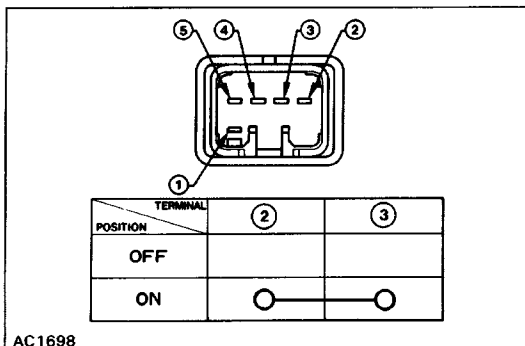

AC1698

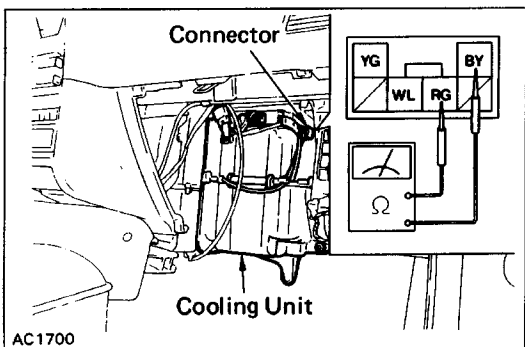

AC1700

## PRESSURE SWITCH

### INSPECTION OF DUAL PRESSURE SWITCH

#### ON-VEHICLE INSPECTION

1. DISCONNECT NEGATIVE CABLE FROM BATTERY
2. REMOVE GLOVE BOX
3. INSPECT PRESSURE SWITCH

- (a) Install the manifold gauge set.
- (b) Observe the gauge reading.
- (c) Check the continuity between the two terminals of the pressure switch shown in the below.

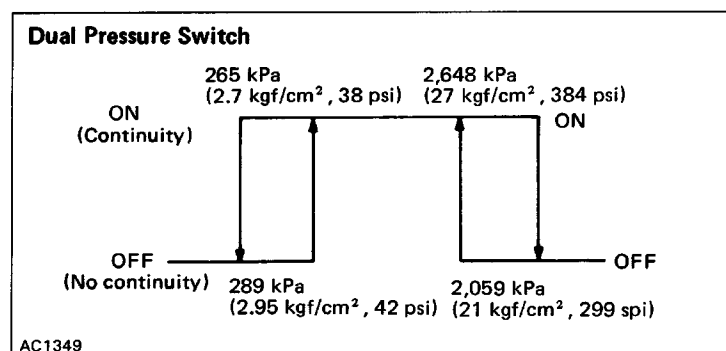

AC1349

If defective, replace the pressure switch.

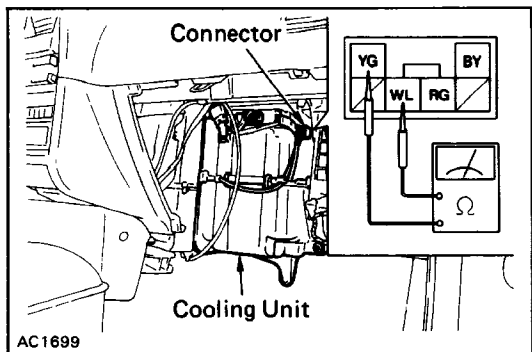

## THERMISTOR

### ON-VEHICLE INSPECTION

1. DISCONNECT NEGATIVE BATTERY CABLE
2. REMOVE GLOVE BOX
3. DISCONNECT CONNECTOR OF THERMISTOR
4. CHECK RESISTANCE OF THERMISTOR

Measure the resistance between terminals.

**Standard resistance: 1,500 at 25°C (77°F)**

If resistance is not as specified, replace the thermistor.

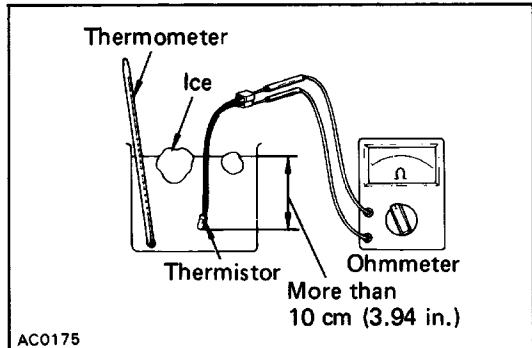

### REMOVAL AND INSPECTION OF THERMISTOR

1. REMOVE AND DISASSEMBLE COOLING UNIT (SEE PAGE AC-25)
2. REMOVE THERMISTOR FROM EVAPORATOR
3. CHECK THERMISTOR OPERATION

(a) Place the thermistor in cold water. While varying the temperature of the water, measure the resistance at the connector and at the same time; measure the temperature of the water with a thermometer.

(b) Compare the two readings on the chart. If the intersection is not between the two lines, replace the thermistor.

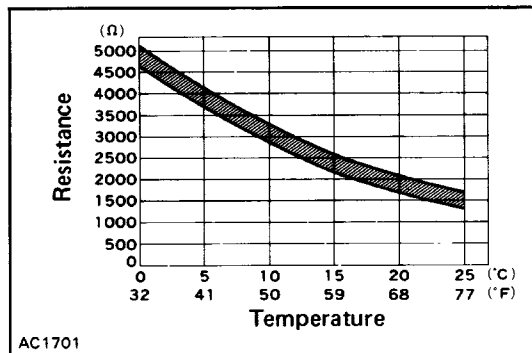

### INSTALLATION OF THERMISTOR

1. INSTALL THERMISTOR TO EVAPORATOR
2. ASSEMBLE AND INSTALL COOLING UNIT

## RELAY

### INSPECTION OF A/C CUT OFF RELAY

#### 4WD Models with 3VZ-E E/G and AM

#### INSPECT A/C CUT OF RELAY CONTINUITY

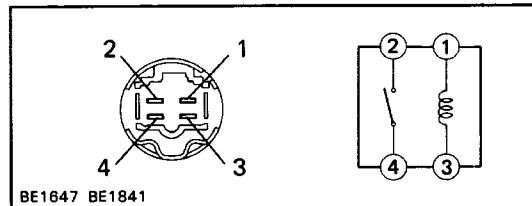

Terminal	1	2	3	4
Condition	1	2	3	4
Constant	○	○○○○	○	
Apply battery positive voltage to terminals 1 and 3.		○		○

If continuity is not as specified, replace the relay.

## Wire Harness Side



K-9-1

# AIR CONDITIONING AMPLIFIER

## INSPECTION OF AMPLIFIER

### INSPECT AMPLIFIER CIRCUIT

Disconnect the amplifier and inspect the connector on the wire harness side as shown in the chart below.

Test conditions:

- (1) Ignition switch: ON
- (2) Temperature control lever: MAX COOL
- (3) Blower switch: HI

Check for	Tester connection	Condition	Specified value
Continuity	7 - 8	Constant	Continuity
	8 - Ground	Constant	Continuity
Voltage	3 - 8	Turn A/C switch on.	Battery positive voltage
		Turn A/C switch off.	Battery positive voltage
	4 - 8	Turn A/C switch on.	Battery positive voltage
		Turn A/C switch off.	No voltage
	6 - 8	Start the engine.	Approx. 10 to 14 V
		Stop the engine.	No voltage
	8 - 9	Turn A/C switch on.	Battery positive voltage
		Turn A/C switch off.	Battery positive voltage
Resistance	5 - 8	Constant	Approx. 1.5 k $\Omega$ at 25°C (77°F)
		MAX COOL	Approx. 0 0
	2 - 5	MIN COOL	Approx. 3 k $\Omega$

If circuit is correct, replace the amplifier.

## VACUUM HOSE CIRCUIT

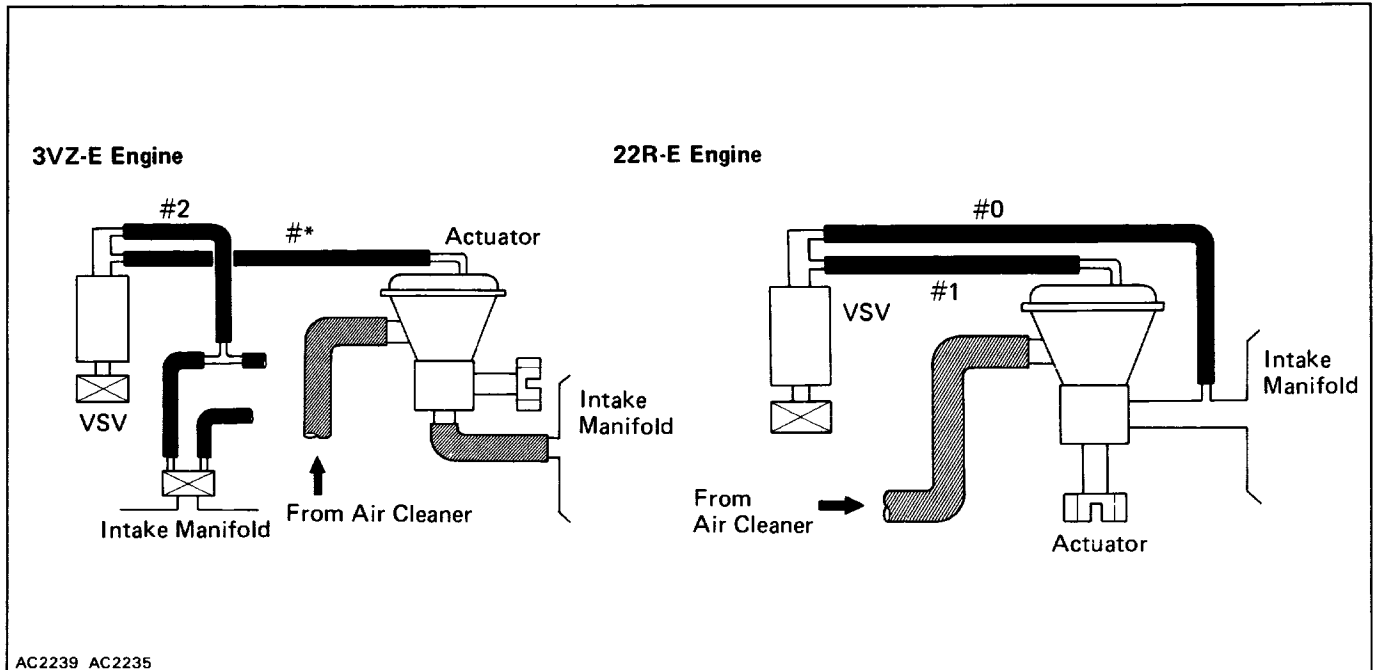

## VACUUM SWITCHING VALVE (VSV) INSPECTION OF VSV

### 1. DISCONNECT VACUUM HOSES AND CONNECTOR FROM VSV

### 2. CHECK VACUUM CIRCUIT CONTINUITY IN VSV BY BLOWING AIR INTO PIPE

- Connect the VSV terminals to the battery terminals as shown.
- Blow into pipe (A), and check that air comes out of pipe (B), but does not come out of filter (C).
- Disconnect the battery.
- Blow into pipe (B) and check that air comes out of filter (C), but does not come out of pipe (A).  
If a problem is found, replace the VSV.

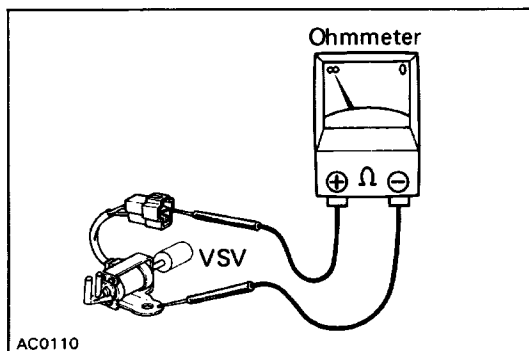
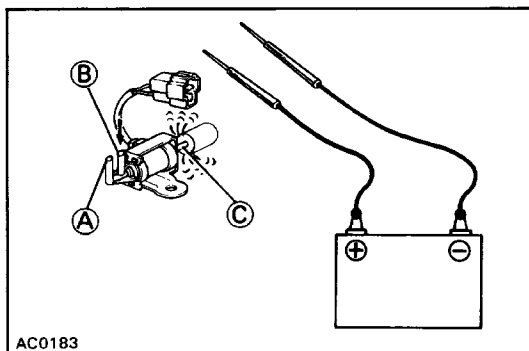
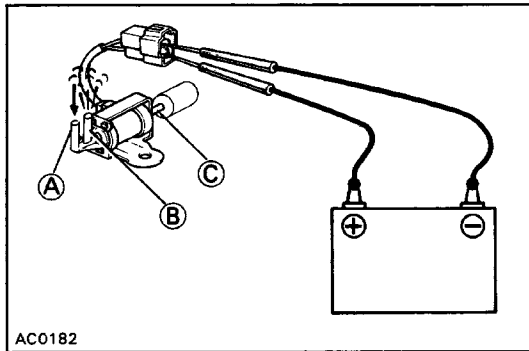

### 3. CHECK FOR SHORT CIRCUIT

Using an ohmmeter, check that there is no continuity between each terminal and the VSV body.

If a short circuit is found, repair or replace the VSV.

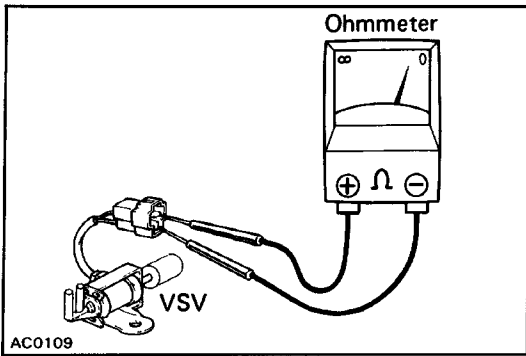

#### 4. CHECK FOR OPEN CIRCUIT

Using an ohmmeter, measure the resistance between two terminals of the VSV.

**Specified resistance: 37 – 42  $\Omega$  at 200C (680F)**

If resistance value is not as specified, replace the VSV.

# HEATER

## Parts Location

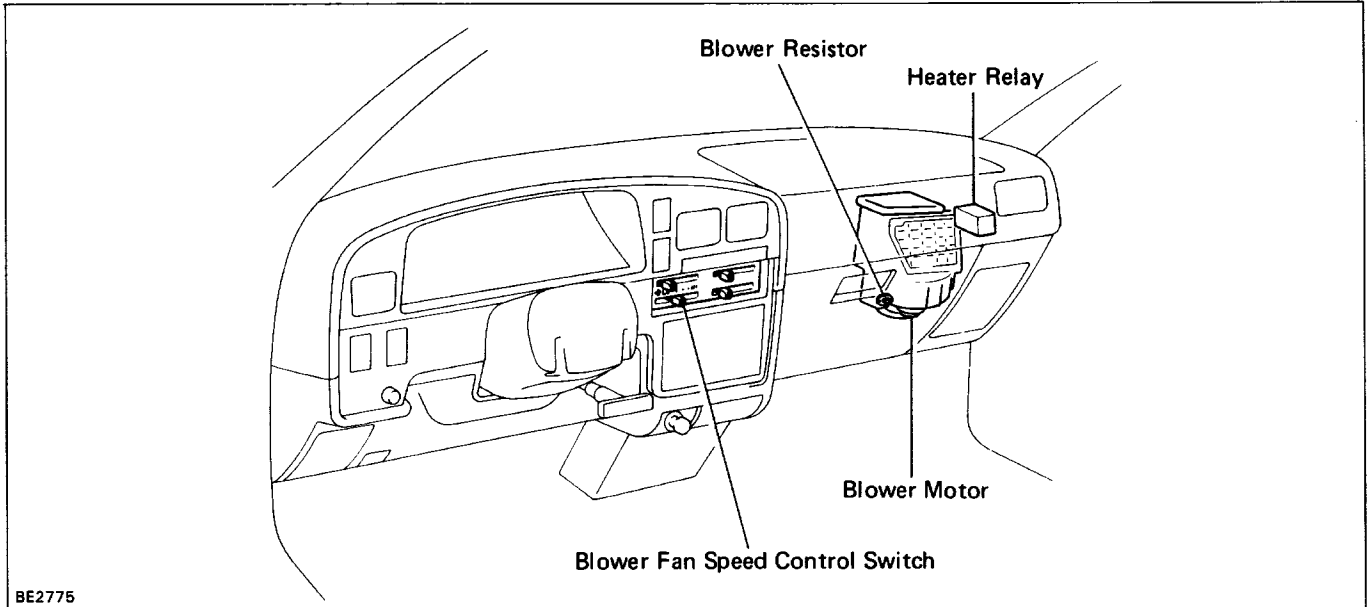

BE2775

## Wiring and Connector Diagrams

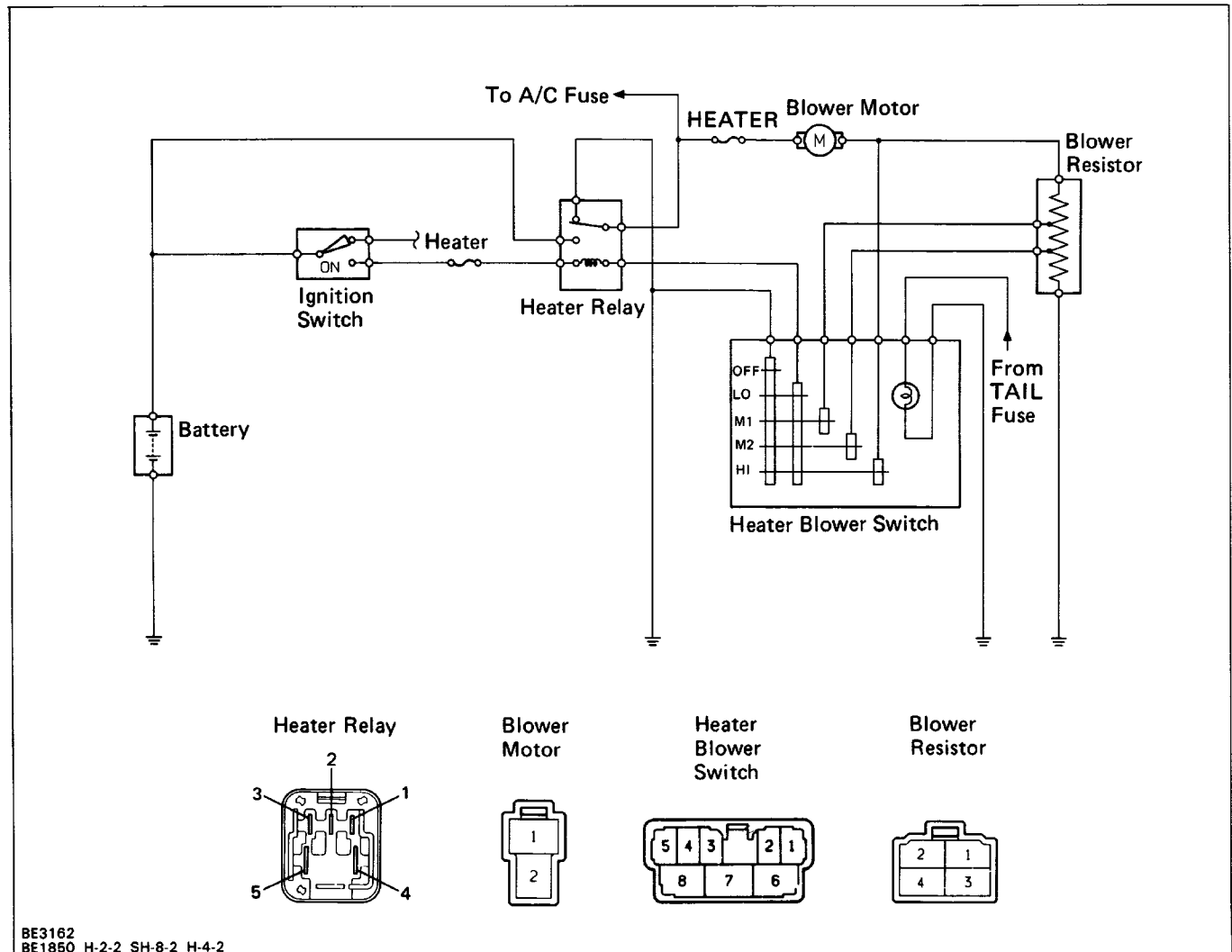

BE3162  
BE1850 H-2-2 SH-8-2 H-4-2

# Troubleshooting

Problem	Possible cause	Remedy	Page
Blower does not work when fan switch is on	HEATER fuse blown Heater relay faulty Heater blower switch faulty Heater blower resistor faulty Heater blower motor faulty Wiring or ground faulty	Replace fuse and check for short Check relay Check switch Check resistor Check motor Repair as necessary	AC-37 AC-37 AC-37 AC-37
Incorrect temperature output	Control cables broken or adjustment faulty Heater hoses leaking or clogged Water valve faulty Air dampers broken	Check cables Replace hose Replace valve Repair dampers	AC-36

# Damper Positions

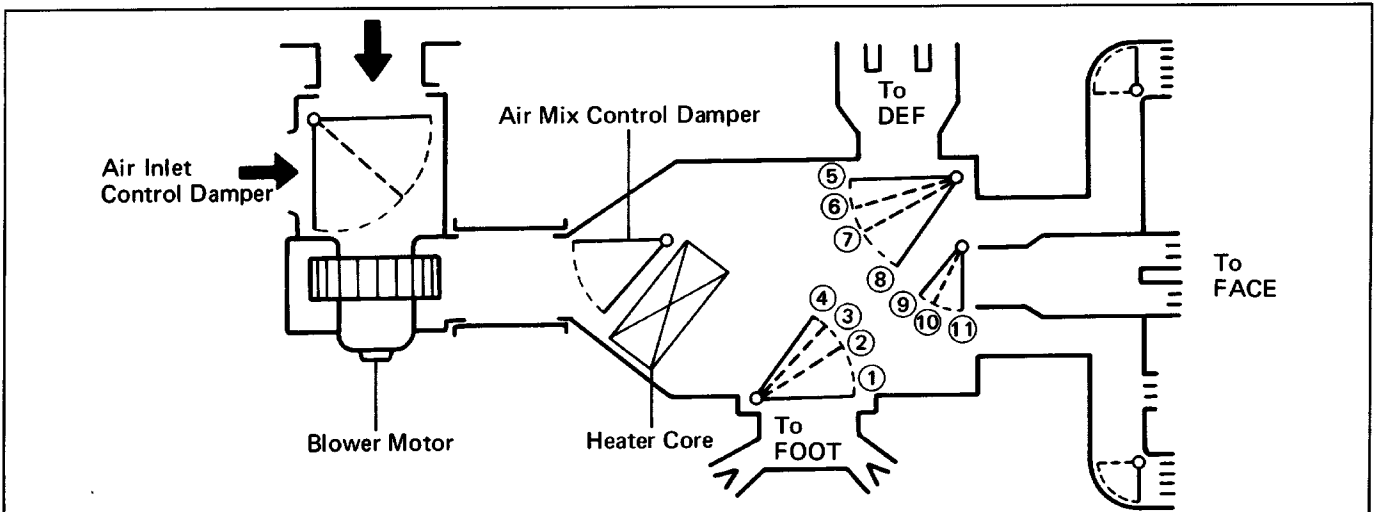

Mode	Air Flow Mode Control Damper Positions	Air Flow Vents					Center of Driver's Seat
		Center	Side	Foot	Def.		
Face	① ⑤ ⑨	○	○			○	
Bi-Level	② ⑤ ⑩	○	○	○		○	
Foot	④ ⑥ ⑪		○	○	○	○	
Foot/Def.	③ ⑦ ⑪		○	○	○	○	
Def.	① ⑧ ⑪		○		○	○	

BE2777 00018E The size of circle (○) indicates the proportion of the air flow volume.



# Inspection and Adjustment

## 1. INSPECT HEATER CONTROL PANEL

### (Heater Control Cable Position)

Move the control levers left and right and check for stiffness and binding through the full range of the levers.

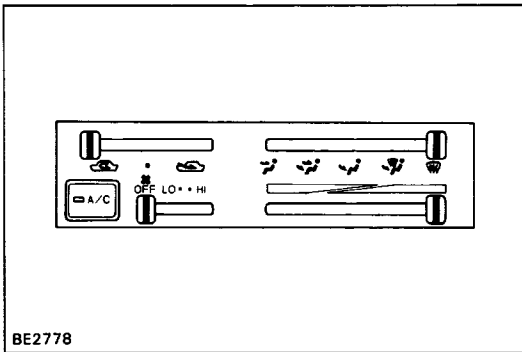

## 2. ADJUST CONTROL DAMPER

### (Air Inlet Control Damper)

Set the air inlet control damper and lever to "FRESH".

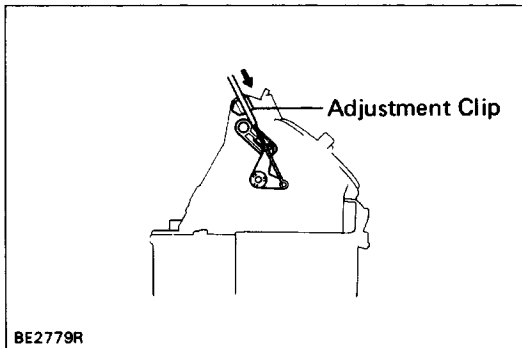

### (Air Flow Control Damper)

Set the air flow control damper and lever to "DEF".

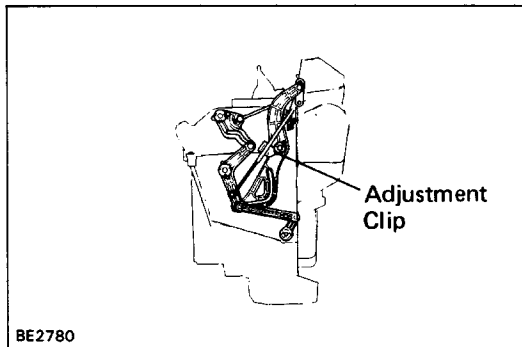

### (Air Mix Control Damper)

Set the air mix control damper and lever to "COOL".

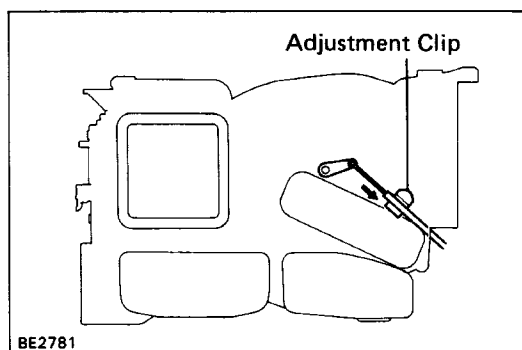

## 3. ADJUST WATER VALVE

### (Water Valve)

Set the water valve and control lever to "COOL".

HINT: Place the water valve lever on "COOL" and while pushing the outer cable in the "COOL" direction, clamp the outer cable to the water valve bracket.

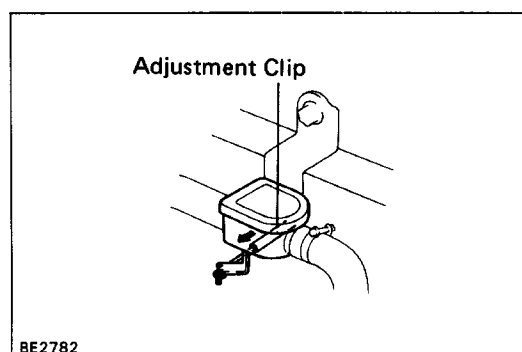



# SERVICE SPECIFICATIONS

## 22R-E ENGINE STARTING SYSTEM

Starter	Rated voltage and output power No-load characteristic Current rpm	12 V, 1.0 kW		12 V, 1.4 kW	
				90 A or less 3,000 rpm or more at 11.5 V	
Brush length	STD Limit	13.5 mm 0.531 in.		15.5 mm 0.610 in.	
Commutator Outer diameter	STD Limit	8.5 mm 0.335 in.		10.0 mm 0.394 in.	
Undercut depth	Limit	30 mm 1.18 in.		←	
	STD	29 mm 1.14 in.		←	
	Limit	0.6 mm 0.024 in.		←	
Circle runout	Limit	0.2 mm 0.008 in.		←	
	STD	0.05 mm 0.0020 in.		←	
Spring installed load		18 - 24 N (1,785-2,415 gf, 3.9-5.3 lbf)		←	
	Limit	12 N (1.2 kgf, 2.6 lbf)		←	

## CHARGING SYSTEM

Battery specific gravity When fully charged at 20°C (68°F)		1.25 - 1.27	
Alternator	Rated output ampere	60 A	
	Rotor coil resistance	2.8 - 3.0 Ω	
	Brush exposed length	STD	10.5 mm 0.413 in.
		Limit	1.5 mm 0.059 in.
Slip ring diameter	STD	14.2 - 14.4 mm 0.559 - 0.567 in.	
	Limit	12.8 mm 0.504 in.	
Alternator regulator	Regulator voltage	at 25°C (77°F) 13.9 - 15.1 V	
		at 115°C (239°F) 13.5 - 14.3 V	

# 3VZ-E ENGINE STARTING SYSTEM

Starter	Rated voltage and output power No-load characteristic Current rpm	12 V, 1.0 kW		12 V, 1.4 kW, 1.6 kW	
				90 A or less	
		3,000 rpm or more at 11.5 V		3,500 rpm or more at 11.5 V	
Brush length	STD	13.5 mm	0.531 in.	15.5 mm	0.610 in.
	Limit	8.5 mm	0.335 in.	10.0 mm	0.394 in.
Commutator Outer diameter	STD	30 mm	1.18 in.	←	
	Limit	29 mm	1.14 in.	←	
Undercut depth	Limit	0.6 mm	0.024 in.	←	
	Limit	0.2 mm	0.008 in.	←	
Circle runout		0.05 mm	0.0020 in.	←	
Spring installed load		18 - 24 N (1,785-2,415 gf, 3.9-5.3 lbf)		←	
	Limit	12 N (1.2 kgf, 2.6 lbf)		←	

# CHARGING SYSTEM

Battery specific gravity When fully charged at 20°C (68°F)	5 5D 2 3R 80D26R	1.25 - 1.27 1.27 - 1.29	
Alternator	Rated output ampere Brush exposed length Rotor coil resistance Slip ring diameter	STD Limit  STD Limit	60 A 10.5 mm 1.5 mm 2.8 - 3.0 Ω 14.2 - 14.4 mm 12.8 mm 0.413 in. 0.059 in. 0.559 - 0.567 in. 0.504 in.
Alternator regulator	Regulator voltage	at 25°C (77°F) at 115°C (239°F)	13.9 - 15.1 V 13.5 - 14.3 V

|

# SERVICE SPECIFICATIONS

# CLUTCH

## Specifications

Pedal height (from asphalt sheet)	2WD	154.5 mm	6.083 in.
	4WD	151.5 mm	5.965 in.
(from floor panel)		157.5 mm	6.201 in.
Push rod play at pedal top		1.0 – 5.0 mm	0.039 – 0.197 in.
Pedal freeplay		5 – 15 mm	0.20 – 0.59 in.
Clutch release point (from pedal full stroke end position)		25 mm (0.98 in.) or more	
Disc rivet head depth	Limit	0.3 mm	0.012 in.
Disc runout	Limit	0.8 mm	0.031 in.
Diaphragm spring tip alignment	Limit	0.5 mm	0.020 in.
Diaphragm spring finger wear Depth	Limit	0.6 mm	0.024 in.
Width	Limit	5.0 mm	0.197 in.
Flywheel runout	Limit	0.1 mm	0.004 in.
Master cylinder reservoir set pin protrusion		1.5 – 3.5 mm	0.059 – 0.138 in.

## Torque Specifications

Part tightened		N·m	kgf·cm	ft·lbf
Master cylinder mounting nut		13	130	9
Release cylinder mounting bolt		12	120	9
Bleeder plug		11	110	8
Clutch cover x Flywheel		19	195	14
Clutch line union		15	155	11
Release fork support	22R-E	39	400	29
	3VZ-E	47	480	35

## MANUAL TRANSMISSION (G57, G58)

### Specifications (2WD and 4WD)

Output shaft			
2nd gear journal diameter	Limit	37.984 mm	1.4954 in.
3rd gear journal diameter	Limit	34.984 mm	1.3773 in.
Flange thickness	Limit	4.80 mm	0.1890 in.
Runout	Limit	0.05 mm	0.0020 in.
Inner race flange thickness	Limit	3.99 mm	0.1571 in.
Inner race outer diameter	Limit	38.985 mm	1.5348 in.
Gear thrust clearance			
1st, 2nd & 3rd	STD	0.10 – 0.25 mm	0.0039 – 0.0098 in.
	Limit	0.25 mm	0.0098 in.
Counter 5th	STD	0.10 – 0.30 mm	0.0039 – 0.0118 in.
	Limit	0.30 mm	0.0118 in.

## CLUTCH

### Specifications

Pedal height (from asphalt sheet)	2WD	154.5 mm	6.083 in.
	4WD	151.5 mm	5.965 in.
(from floor panel)		157.5 mm	6.201 in.
Push rod play at pedal top		1.0 – 5.0 mm	0.039 – 0.197 in.
Pedal freeplay		5 – 15 mm	0.20 – 0.59 in.
Clutch release point (from pedal full stroke end position)		25 mm (0.98 in.) or more	
Disc rivet head depth	Limit	0.3 mm	0.012 in.
Disc runout	Limit	0.8 mm	0.031 in.
Diaphragm spring tip alignment	Limit	0.5 mm	0.020 in.
Diaphragm spring finger wear Depth	Limit	0.6 mm	0.024 in.
Width	Limit	5.0 mm	0.197 in.
Flywheel runout	Limit	0.1 mm	0.004 in.
Master cylinder reservoir set pin protrusion		1.5 – 3.5 mm	0.059 – 0.138 in.

## Torque Specifications

Part tightened	N·m	kgf·cm	ft·lbf
Master cylinder mounting nut	13	130	9
Release cylinder mounting bolt	12	120	9
Bleeder plug	11	110	8
Clutch cover x Flywheel	19	195	14
Clutch line union	15	155	11
Release fork support	22R-E	39	29
	3VZ-E	47	35

## MANUAL TRANSMISSION (G57 G58)

### Specifications (2WD and 4WD)

Output shaft			
2nd gear journal diameter	Limit	37.984 mm	1.4954 in.
3rd gear journal diameter	Limit	34.984 mm	1.3773 in.
Flange thickness	Limit	4.80 mm	0.1890 in.
Runout	Limit	0.05 mm	0.0020 in.
Inner race flange thickness	Limit	3.99 mm	0.1571 in.
Inner race outer diameter	Limit	38.985 mm	1.5348 in.
Gear thrust clearance			
1st, 2nd & 3rd	STD	0.10 – 0.25 mm	0.0039 – 0.0098 in.
	Limit	0.25 mm	0.0098 in.
Counter 5th	STD	0.10 – 0.30 mm	0.0039 – 0.0118 in.
	Limit	0.30 mm	0.0118 in.



## Specifications (2WD and 4WD) (Cont'd)

Gear oil clearance			
1 st, 2nd & 3rd	STD	0.009 – 0.032 mm	0.0004 – 0.0013 in.
	Limit	0.032 mm	0.0013 in.
5th	STD	0.009 – 0.032 mm	0.0004 – 0.0013 in.
	Limit	0.032 mm	0.0013 in.
Reverse	STD	0.04 – 0.08 mm	0.0016 – 0.0031 in.
	Limit	0.13 mm	0.0051 in.
Shift fork to hub sleeve clearance	Limit	1.0 mm	0.039 in.
Synchronizer ring to gear clearance	STD	1.0 – 2.0 mm	0.039 – 0.079 in.
	Limit	0.8 mm	0.031 in.
Front bearing retainer oil seal			
Drive in depth		12.2 – 13.2 mm	0.480 – 0.520 in.
Speedometer driven gear oil seal			
Oil seal depth		20 mm	0.79 in.
Input shaft synchronizer ring to gear clearance	STD	1.0 – 2.0 mm	0.039 – 0.079 in.
	Limit	0.8 mm	0.031 in.
Counter gear outer diameter of needle roller bearing race	STD	25.98 – 26.00 mm	1.0228 – 1.0236 in.
	Limit	25.86 mm	1.0181 in.
Reverse idler gear to shift arm shoe clearance	STD	0.05 – 0.27 mm	0.0020 – 0.0106 in.
	Limit	0.5 mm	0.197 in.
Input shaft snap ring thickness	Mark		
	0	2.05 – 2.10 mm	0.0807 – 0.0827 in.
	1	2.10 – 2.15 mm	0.0827 – 0.0846 in.
	2	2.15 – 2.20 mm	0.0846 – 0.0866 in.
	3	2.20 – 2.25 mm	0.0866 – 0.0886 in.
	4	2.25 – 2.30 mm	0.0886 – 0.0906 in.
	5	2.30 – 2.35 mm	0.0906 – 0.0925 in.
Output shaft snap ring thickness			
Front	Mark		
	C-1	1.75 – 1.80 mm	0.0689 – 0.0709 in.
	D	1.80 – 1.85 mm	0.0709 – 0.0728 in.
	D-1	1.85 – 1.90 mm	0.0728 – 0.0748 in.
	E	1.90 – 1.95 mm	0.0748 – 0.0768 in.
	E-1	1.95 – 2.00 mm	0.0768 – 0.0787 in.
	F	2.00 – 2.05 mm	0.0787 – 0.0807 in.
Rear	F-1	2.05 – 2.10 mm	0.0807 – 0.0827 in.
	Mark		
	A	2.67 – 2.72 mm	0.1051 – 0.1071 in.
	B	2.73 – 2.78 mm	0.1075 – 0.1094 in.
	C	2.79 – 2.84 mm	0.1098 – 0.1118 in.
	D	2.85 – 2.90 mm	0.1122 – 0.1142 in.
E	2.91 – 2.96 mm	0.1146 – 0.1165 in.	
F	2.97 – 3.02 mm	0.1169 – 0.1189 in.	

**Specifications (2WD and 4WD) (Cont'd)**

Output shaft snap ring thickness (cont'd)			
Rear	Mark		
	G	3.03 – 3.08 mm	0.1193 – 0.1213 in.
	H	3.09 – 3.14 mm	0.1217 – 0.1236 in.
	J	3.15 – 3.20 mm	0.1240 – 0.1260 in.
	K	3.21 – 3.26 mm	0.1264 – 0.1283 in.
	L	3.27 – 3.32 mm	0.1287 – 0.1307 in.
Counter gear snap ring			
Front bearing	Mark		
	1	2.05 – 2.10 mm	0.0807 – 0.0827 in.
	2	2.10 – 2.15 mm	0.0827 – 0.0846 in.
	3	2.15 – 2.20 mm	0.0846 – 0.0866 in.
	4	2.20 – 2.25 mm	0.0866 – 0.0886 in.
	5	2.25 – 2.30 mm	0.0886 – 0.0906 in.
	6	2.30 – 2.35 mm	0.0906 – 0.0925 in.
Gear spline piece No. 5 (5–speed) or oil separator (4–speed)			
	Mark		
	A	2.80 – 2.85 mm	0.1102 – 0.1122 in.
	B	2.85 – 2.90 mm	0.1122 – 0.1142 in.
	C	2.90 – 2.95 mm	0.1142 – 0.1161 in.
	D	2.95 – 3.00 mm	0.1161 – 0.1181 in.
	E	3.00 – 3.05 mm	0.1181 – 0.1201 in.
	F	3.05 – 3.10 mm	0.1201 – 0.1220 in.
	G	3.10 – 3.15 mm	0.1220 – 0.1240 in.

**Torque Specifications (2WD and 4WD)**

Part tightened	N·m	kgf·cm	ft·lbf
Straight screw plug	19	190	14
Extension housing or transfer adaptor x Transmission case	37	380	27
Restrict pin	27	280	20
Shift lever retainer x Extension housing	18	185	13
Back–up light switch	37	380	27
Front bearing retainer x Transmission case	17	170	12
Rear bearing retainer x Intermediate plate	18	185	13
Reverse shift arm bracket	18	185	13
Reverse idler gear shaft stopper bolt	17	175	13
Clutch housing x Transmission case	37	380	27
Shift lever housing bolt	38	390	28
Shift fork x Fork shaft	20	200	14
Speedometer driven gear lock plate (2WD)	11	115	8
Oil receiver x Extension housing (2WD)	11	115	8
Oil receiver x Transfer adaptor (4WD )	13	130	9

**MANUAL TRANSMISSION (R150 R150F)****Specifications (2WD and 4WD)**

Output shaft			
1 st gear journal diameter	Limit	38.860 mm	1.5299 in.
2nd gear journal diameter	Limit	46.860 mm	1.8449 in.
3rd gear journal diameter	Limit	37.860 mm	1.4905 in.
Flange thickness	Limit	4.70 mm	0.1850 in.
Runout	Limit	0.06 mm	0.0024 in.
Counter gear			
Roller bearing journal diameter	Limit	27.860 mm	1.0968 in.
Gear thrust clearance			
1 st	STD	0.10 – 0.45 mm	0.0039 – 0.0177 in.
	Limit	0.50 mm	0.0197 in.
2nd & 3rd	STD	0.10 – 0.25 mm	0.0039 – 0.0098 in.
	Limit	0.30 mm	0.0118 in.
Counter 5th	STD	0.10 – 0.35 mm	0.0039 – 0.0138 in.
	Limit	0.40 mm	0.0157 in.
Gear oil clearance			
1 st	STD	0.020 – 0.073 mm	0.0008 – 0.0029 in.
	Limit	0.16 mm	0.0063 in.
2nd, 3rd & Counter 5th	STD	0.015 – 0.068 mm	0.0006 – 0.0027 in.
	Limit	0.16 mm	0.0063 in.
Reverse	STD	0.040 – 0.082 mm	0.0016 – 0.0032 in.
	Limit	0.13 mm	0.0051 in.
Shift fork to hub sleeve clearance	Limit	1.0 mm	0.039 in.
Synchronizer ring to gear clearance	STD	0.8 – 1.6 mm	0.031 – 0.063 in.
	Limit	0.6 mm	0.024 in.
Oil seal drive in depth			
Front bearing retainer		10.5 – 11.5 mm	0.413 – 0.453 in.
Speedometer driven gear		25 mm	0.98 in.
Input shaft to synchronizer ring	STD	0.8 – 1.6 mm	0.031 – 0.063 in.
	Limit	0.6 mm	0.024 in.
Reverse idler gear to shift arm shoe	STD	0.05 – 0.25 mm	0.0020 – 0.098 in.
	Limit	0.5 mm	0.020 in.
Input shaft snap ring thickness	Mark		
	A	2.10 – 2.15 mm	0.0827 – 0.0846 in.
	B	2.15 – 2.20 mm	0.0846 – 0.0866 in.
	C	2.20 – 2.25 mm	0.0866 – 0.0886 in.
	D	2.25 – 2.30 mm	0.0886 – 0.0906 in.
	E	2.30 – 2.35 mm	0.0906 – 0.0925 in.
	F	2.35 – 2.40 mm	0.0925 – 0.0945 in.
	G	2.40 – 2.45 mm	0.0945 – 0.0965 in.

## Specifications (2WD and 4WD) (Cont'd)

Counter gear snap ring (Front bearing)	Mark		
	A	2.00 – 2.05 mm	0.0787 – 0.0807 in.
	B	2.05 – 2.10 mm	0.0807 – 0.0827 in.
	C	2.10 – 2.15 mm	0.0827 – 0.0846 in.
	D	2.15 – 2.20 mm	0.0846 – 0.0866 in.
	E	2.20 – 2.25 mm	0.0866 – 0.0886 in.
Output shaft snap ring thickness			
Clutch hub No.2	Mark		
	A	1.80 – 1.85 mm	0.0709 – 0.0728 in.
	B	1.85 – 1.90 mm	0.0728 – 0.0748 in.
	C	1.90 – 1.95 mm	0.0748 – 0.0768 in.
	D	1.95 – 2.00 mm	0.0768 – 0.0787 in.
	E	2.00 – 2.05 mm	0.0787 – 0.0807 in.
	F	2.05 – 2.10 mm	0.0807 – 0.0827 in.
	G	2.10 – 2.15 mm	0.0827 – 0.0846 in.
Clutch hub No. 1	Mark		
	A	2.30 – 2.35 mm	0.0906 – 0.0925 in.
	B	2.35 – 2.40 mm	0.0925 – 0.0945 in.
	C	2.40 – 2.45 mm	0.0945 – 0.0965 in.
	D	2.45 – 2.50 mm	0.0965 – 0.0984 in.
	E	2.50 – 2.55 mm	0.0984 – 0.1004 in.
	F	2.55 – 2.60 mm	0.1004 – 0.1024 in.
	G	2.60 – 2.65 mm	0.1024 – 0.1043 in.
Rear	Mark		
	A	2.65 – 2.70 mm	0.1043 – 0.1063 in.
	B	2.70 – 2.75 mm	0.1063 – 0.1083 in.
	C	2.75 – 2.80 mm	0.1083 – 0.1102 in.
	D	2.80 – 2.85 mm	0.1102 – 0.1122 in.
	E	2.85 – 2.90 mm	0.1122 – 0.1142 in.
	F	2.90 – 2.95 mm	0.1142 – 0.1161 in.
	G	2.95 – 3.00 mm	0.1161 – 0.1181 in.
	H	3.00 – 3.05 mm	0.1181 – 0.1201 in.
	J	3.05 – 3.10 mm	0.1201 – 0.1220 in.
	K	3.10 – 3.15 mm	0.1220 – 0.1240 in.
	L	3.15 – 3.20 mm	0.1240 – 0.1260 in.
	M	3.20 – 3.25 mm	0.1260 – 0.1280 in.
	N	3.25 – 3.30 mm	0.1280 – 0.1299 in.
	P	3.30 – 3.35 mm	0.1299 – 0.1319 in.
Q	3.35 – 3.40 mm	0.1319 – 0.1339 in.	
R	3.40 – 3.45 mm	0.1339 – 0.1358 in.	
S	3.45 – 3.50 mm	0.1358 – 0.1378 in.	

## Torque Specifications (2WD and 4WD)

Part tightened	N·m	kgf·cm	ft·lbf
Reverse shift arm bracket	18	185	13
Rear bearing retainer x Intermediate plate	18	185	13
Counter gear rear lock nut	127	1,300	94
Shift fork x Shift fork shaft	20	200	14
Straight screw plug	19	190	14
Front bearing retainer x Transmission case	17	170	12
Transmission case x Extension housing	37	380	27
Shift lever housing bolt	38	390	28
Clutch housing x Transmission case	36	370	27
Oil receiver x Extension housing	11	115	8
Back-up light switch	44	450	33
Restrict pin	37	380	27
Shift lever retainer x Extension housing or transfer adaptor	18	185	13

## MANUAL TRANSMISSION (installation of Transmission)

### Torque Specifications (2WD)

Part tightened	N·m	kgf·cm	ft·lbf
Transmission x Engine	72	730	53
Stiffener plate x Transmission	37	380	27
Starter	39	400	29
Engine rear mounting x Transmission	25	260	19
Clutch tube bracket x Transmission (22R-E)	72	730	53
Clutch release cylinder	12	120	9
Stabilizer bracket	29	300	22
Frame auxiliary crossmember	95	970	70
Engine rear mounting bracket x Support member	58	590	43
Engine rear mounting bracket x Engine rear mounting	29	300	22
Exhaust pipe x Exhaust manifold	62	630	46
Exhaust pipe bracket x Clutch housing			
(22R-E)			
Upper	19	195	14
Lower	69	700	51
(3VZ-E)	39	400	29
Exhaust pipe x Catalytic converter front side (3VZ-E)	39	400	29
Exhaust pipe clamp	19	195	14

## Torque Specifications (4WD)

Part tightened		N·m	kgf·cm	ft·lbf
Transfer x Transfer adaptor	W56	39	400	29
	G58, R 150F	37	380	27
Engine rear mounting		25	260	19
Transfer x Dynamic damper (Regular cab w/ Planetary gear type transfer)		37	380	27
Transmission x Engine		72	730	53
Transmission x Stiffener plate		37	380	27
Starter		39	400	29
No. 2 crossmember x Frame		95	970	70
No. 2 crossmember x Engine rear mounting		13	130	9
Stabilizer bracket		29	300	22
Front differential carrier cover x Frame (3VZ-E)		147	1,500	168
Front differential carrier x Frame (3VZ-E)		167	1,700	123
Exhaust pipe x Exhaust manifold		62	630	46
Exhaust pipe bracket x Clutch housing	(22R-E)			
	Upper	19	195	14
	Lower	69	700	51
	(3VZ-E)	39	400	29
Exhaust pipe x Catalytic converter front side (3VZ-E)		39	400	29
Exhaust pipe clamp		19	195	14
Clutch release cylinder x Transmission		12	120	9
Propeller shaft dust cover subassembly (G 58, R 150F)		37	370	27
	A-bolt	23	230	17
	B-bolt	74	750	54
Front propeller shaft x Front differential		74	750	54
Front propeller shaft x Transfer		74	750	54
Rear propeller shaft x Rear differential	3VZ-E	76	780	56
	22R-E	74	750	54
Rear propeller shaft x Transfer	3VZ-E	76	780	56
	22R-E	74	750	54
Rear propeller shaft center bearing x Frame		37	370	27

# AUTOMATIC TRANSMISSION (A43D)

## Specifications

Line pressure							
Engine idling	D range		427 – 481 kPa	4.3 – 4.9 kgf/cm <sup>2</sup>	61 – 70 psi		
		R range	510 – 608 kPa	5.2 – 6.2 kgf/cm <sup>2</sup>	74 – 88 psi		
At stall (Throttle valve fully opened)	D range		1,118 – 1,363 kPa	11.4 – 13.9 kgf/cm <sup>2</sup>	162 – 198 psi		
		R range	1,373 – 1,716 kPa	14.0 – 17.5 kgf/cm <sup>2</sup>	199 – 249 psi		
Engine stall revolution			1,900 ± 150 rpm				
Time lag	N range →	D range	Less than 1.2 seconds				
	N range →	R range	Less than 1.5 seconds				
Engine idle speed (A/C OFF)		N range	750 rpm				
Governor pressure (Vehicle speed reference)							
Output shaft rpm	Tire size						
	(P195/75R14)	(P205/75R14)					
	1,000	32 km/h (20 mph)	32 km/h (20 mph)	88 – 147 kPa	0.9 – 1.5 kgf/cm <sup>2</sup>	13 – 21 psi	
	1,800	57 km/h (35 mph)	58 km/h (36 mph)	157 – 216 kPa	1.6 – 2.2 kgf/cm <sup>2</sup>	23 – 31 psi	
3,500	111 km/h (69 mph)	113 km/h (70 mph)	402 – 520 kPa	4.1 – 5.3 kgf/cm <sup>2</sup>	58 – 75 psi		
Throttle cable adjustment							
Throttle valve fully opened			Between boot end face and inner cable stopper				
			0 – 1 mm	0 – 0.04 in.			
Torque converter sleeve runout		Limit	0.30 mm	0.0118 in.			
Torque converter installation distance			20.0 mm	0.787 in.			
Drive plate runout		Limit	0.20 mm	0.0079 in.			
Shift point km/h (mph)	Throttle valve fully open [ ] Fully closed						
	D range (2 range)						L range
	1 → 2	2 → 3	[3 → O/D]	O/D → 3	3 → 2	2 → 1	2 → 1
	57 – 73 (35 – 45)	106 – 124 (66 – 77)	38 – 52 (24 – 32)	*	95 – 112 (59 – 70)	36 – 49 (22 – 30)	46 – 62 (29 – 39)
	* O/D → 3 down-shift is possible up to maximum speed.						

## Torque Specifications

Part tightened	N·m	kgf·cm	ft·lbf	
Oil cooler pipe union nut	34	350	25	
Torque converter x Drive plate	27	280	20	
Drive plate x Crankshaft	83	850	61	
Extension housing x Transmission case	34	345	25	
Center support x Transmission case	25	260	19	
Parking lock pawl bracket	7.4	75	65 in.·lbf	
Valve body x Transmission case	10	100	7	
Throttle cam	7.4	75	65 in.·lbf	
Oil strainer	5.4	55	48 in.·lbf	
Oil pan	4.4	45	39 in.·lbf	
Governor body	3.9	40	35 in.·lbf	
Overdrive solenoid	13	130	9	
Control shaft lever	6.9	70	61 in.·lbf	
Cooler union	34	350	25	
Neutral start switch				
	Bolt	5.4	55	48 in.·lbf
	Nut	3.9	40	35 in.·lbf



# AUTOMATIC TRANSMISSION (A340E)

## Specifications

Line pressure					
Engine idling	D range		363 - 422 kPa	3.7 - 4.3 kgf/cm <sup>2</sup>	53 - 61 psi
		R range	490 - 588 kPa	5.0 - 6.0 kgf/cm <sup>2</sup>	71 - 85 psi
At stall (Throttle valve fully opened)	D range		932 - 1,178 kPa	9.5 - 12.0 kgf/cm <sup>2</sup>	135 - 171 psi
		R range	1,294 - 1,638 kPa	13.2 - 16.7 kgf/cm <sup>2</sup>	188 - 238 psi
Engine stall revolution	C&C		2,200 ± 150rpm		
		Except C&C	2,450 ± 150rpm		
Time lag	N range → D range		Less than 1.2 seconds		
	N range → R range		Less than 1.5 seconds		
Engine idling speed (A/C OFF)	N range		800 rpm		
Throttle cable adjustment					
Throttle valve fully opened			Between boot end face and inner cable stopper		
			0 - 1 mm		0 - 0.04 in.
Torque converter sleeve runout	Limit		0.30 mm		0.0118 in.
Torque converter installation distance			18.0 mm		0.709 in.
Drive plate runout	Limit		0.20 mm		0.0079 in.

Shift point CBU Tire size: P205/75R14 P215/65R15 km/h (mph)			Throttle valve fully open [ ] Fully closed							
			1 → 2	2 → 3	3 → O/D	[3 → O/D]	[O/D → 3]	O/D → 3	3 → 2	2 → 1
	D range	NORM	61-66 (38-41)	108-117 (67-73)	143-152 (89-94)	43-48 (27-30)	26-30 (16-19)	136-145 (85-90)	100-105 (62-65)	44-49 (27-30)
		PWR	61-66 (38-41)	119-127 (74-79)	147-156 (91-97)	47-52 (29-32)	26-30 (16-19)	140-149 (87-93)	110-119 (68-74)	44-49 (27-30)
	2 range	NORM PWR	53-57 (33-35)	126-135 (78-84)	-	-	-	-	119-128 (74-80)	47-52 (29-32)
L range	NORM PWR	-	-	-	-	-	-	101-110 (63-68)	57-62 (35-39)	

Lock-up point CBU Tire size: P205/75R14 P215/65R15 km/h (mph)			Throttle valve opening 5%					
			Lock-up ON			Lock-up OFF		
			2nd	*3rd	O/D	2nd	*3rd	O/D
	D range	NORM	-	79-83 (49-52)	79-83 (49-52)	-	71-76 (44-47)	68-73 (42-45)
		PWR	-	61-66 (38-41)	79-83 (49-52)	-	68-73 (42-45)	68-76 (42-47)

\* O/D switch OFF

Shift point CBU Tire size: 185R14-8 km/h (mph)			Throttle valve fully open [ ] Fully closed							
			1 → 2	2 → 3	3 → O/D	[3 → O/D]	[O/D → 3]	O/D → 3	3 → 2	2 → 1
	D range	NORM	52-56 (32-35)	73-100 (45-62)	135-142 (84-88)	37-41 (23-25)	22-26 (14-16)	130-136 (81-85)	86-90 (53-56)	43-47 (27-29)
		PWR	52-56 (32-35)	102-109 (63-68)	148-154 (92-96)	40-44 (25-27)	22-26 (14-16)	141-148 (88-92)	95-102 (59-63)	43-47 (27-29)
	2 range	NORM PWR	45-49 (28-30)	108-115 (67-71)	-	-	-	-	102-109 (63-68)	40-44 (25-27)
L range	NORM PWR	-	-	-	-	-	-	87-94 (54-58)	49-53 (30-33)	

Lock-up point CBU Tire size: 185R14-8 km/h (mph)			Throttle valve opening 5%					
			Lock-up ON			Lock-up OFF		
			2nd	*3rd	O/D	2nd	*3rd	O/D
	D range	NORM	-	67-71 (42-44)	68-71 (42-44)	-	61-65 (38-40)	58-62 (36-39)
		PWR	-	58-62 (36-39)	68-71 (42-44)	-	52-56 (32-35)	61-65 (38-40)

\* O/D switch OFF

## Specifications (Cont'd)

Shift point			Throttle valve fully open [ ] Fully closed							
			1 → 2	2 → 3	3 → O/D	[3 → O/D]	[O/D → 3]	O/D → 3	3 → 2	2 → 1
C & C Tire size: 185R14-8 185R14-6 (Double tire) km/h (mph)	D range	NORM	43-47 (27-29)	84-91 (52-57)	129-135 (80-84)	73-77 (45-48)	21-25 (13-16)	123-130 (76-81)	77-81 (48-50)	38-42 (24-26)
		PWR	51-55 (32-34)	97-103 (60-64)	132-138 (82-86)	73-77 (45-48)	21-25 (13-16)	126-132 (78-82)	90-97 (56-60)	45-48 (28-30)
	2 range	NORM PWR	43-47 (27-29)	103-110 (64-68)	-	-	-	-	97-104 (60-65)	38-42 (24-26)
	L range	NORM PWR	-	-	-	-	-	-	83-89 (52-55)	47-51 (29-32)
Lock-up point C & C Tire size: 185R14-8 185R14-6 (Double tire) km/h (mph)			Throttle valve opening 5%							
			Lock-up ON				Lock-up OFF			
			2nd	*3rd	O/D	2nd	*3rd	O/D		
	D range	NORM	-	73-77 (45-48)	73-77 (45-48)	-	61-65 (38-40)	67-71 (42-44)		
PWR		-	73-77 (45-48)	73-77 (45-48)	-	67-71 (42-44)	67-71 (42-44)			
* O/D switch OFF										
Shift point C & C Tire size: 185R14-6 (Double tire) km/h (mph) (Differential gear ratio) 4.300			Throttle valve fully open [ ] Fully closed							
			1 → 2	2 → 3	3 → O/D	[3 → O/D]	[O/D → 3]	O/D → 3	3 → 2	2 → 1
	D range	NORM	41-45 (25-28)	80-87 (50-54)	123-129 (76-80)	69-73 (43-45)	20-24 (12-15)	117-124 (73-77)	73-77 (45-48)	37-40 (23-25)
		PWR	49-53 (30-33)	92-99 (57-62)	126-132 (78-82)	69-73 (43-45)	20-24 (12-15)	120-126 (75-78)	86-92 (53-57)	42-46 (26-29)
2 range	NORM PWR	41-45 (25-28)	98-105 (61-65)	-	-	-	-	93-99 (58-62)	37-40 (23-25)	
L range	NORM PWR	-	-	-	-	-	-	79-85 (49-53)	45-48 (28-30)	
Lock-up point C & C Tire size: 185R14-6 (Double tire) km/h (mph) (Differential gear ratio) 4.300			Throttle valve opening 5%							
			Lock-up ON				Lock-up OFF			
			2nd	*3rd	O/D	2nd	*3rd	O/D		
	D range	NORM	-	69-73 (43-45)	69-73 (43-45)	-	58-62 (36-39)	64-68 (40-42)		
PWR		-	69-73 (43-45)	69-73 (43-45)	-	64-68 (40-42)	64-68 (40-42)			
* O/D switch OFF										

## Torque Specifications

Part tightened	N·m	kgf·cm	ft·lbf
Oil cooler pipe union nut	34	350	25
Torque converter x Drive plate	41	420	30
Drive plate x Crankshaft	83	850	61
Extension housing x Transmission case	36	370	27
Parking lock pawl bracket	7.4	75	65 in.·lbf
Valve body x Transmission case	10	100	7
Detent spring x Valve body	10	100	7
Solenoid x Valve body	10	100	7
Oil strainer	10	100	7
Oil pan	7.4	75	65 in.·lbf
Speed sensor	16	160	12
Speedometer driven gear lock plate	16	160	12

## Torque Specifications (Cont'd)

Part tightened		N·m	kgf·cm	ft·lbf
Cooler union		29	300	22
Neutral start switch	Bolt	13	130	9
	Nut	6.9	70	61 in·lbf
Control shaft lever		16	160	12

## AUTOMATIC TRANSMISSION (A340H) Specifications

Line pressure										
Engine idling	D range	422 – 481 kPa	4.3 – 4.9 kgf/cm <sup>2</sup>	61 – 70 psi						
		520 – 618 kPa	5.3 – 6.3 kgf/cm <sup>2</sup>	75 – 90 psi						
At stall (Throttle valve fully opened)	D range	1,118 – 1,363 kPa	11.4 – 13.9 kgf/cm <sup>2</sup>	162 – 198 psi						
		1,373 – 1,716 kPa	14.0 – 17.5 kgf/cm <sup>2</sup>	199 – 249 psi						
Engine stall revolution		2,850 ± 150 rpm								
Time lag	N range → D range	Less than 1.2 seconds								
	N range → R range	Less than 1.5 seconds								
Engine idling speed (A/C OFF)	N range	850 rpm								
Throttle cable adjustment										
Throttle valve fully opened		Between boot end face and inner cable stopper								
		0 – 1 mm	0 – 0.04 in.							
Torque converter sleeve runout	Limit	0.30 mm	0.0118 in.							
Torque converter installation distance		18.0 mm	0.709 in.							
Drive plate runout	Limit	0.20 mm	0.0079 in.							
Shift point km/h (mph)	Transfer shift position "H2" or "H4"	Throttle valve fully open [ ] Fully closed								
		1 → 2	2 → 3	3 → O/D	[3 → O/D]	[O/D → 3]	O/D → 3	3 → 2	2 → 1	
	D range	NORM	50–53 (31–33)	90–96 (56–60)	131–138 (81–86)	35–39 (22–24)	21–25 (13–16)	125–132 (78–82)	84–91 (52–57)	40–44 (25–27)
		PWR	50–53 (31–33)	90–96 (56–60)	131–138 (81–86)	38–42 (24–26)	21–25 (13–16)	125–132 (78–82)	84–91 (52–57)	40–44 (25–27)
	2 range	NORM PWR	43–46 (27–29)	103–109 (64–68)	–	–	–	–	97–103 (60–64)	38–42 (24–42)
L range	NORM PWR	–	–	–	–	–	–	82–89 (51–55)	47–51 (29–32)	
Lock-up point km/h (mph)	Transfer shift position "H2" or "H4"	Throttle valve opening 5 %								
		Lock-up ON				Lock-up OFF				
		2nd	*3rd	O/D	2nd	*3rd	O/D			
	D range	NORM	–	52–56 (32–35)	64–68 (40–42)	–	50–53 (31–33)	55–59 (34–37)		
		PWR	–	52–56 (32–35)	64–68 (40–42)	–	50–53 (31–33)	55–59 (34–37)		
* O/D switch OFF										

## Torque Specifications (Refer to the A340E automatic transmission)

# AUTOMATIC TRANSMISSION (A340F)

## Specifications

Line pressure										
Engine idling	D range		363 – 422 kPa	3.7 – 4.3 kgf/cm <sup>2</sup>	53 – 61 psi					
		R range	490 – 588 kPa	5.0 – 6.0 kgf/cm <sup>2</sup>	71 – 85 psi					
At stall	D range		932 – 1,177 kPa	9.5 – 12.0 kgf/cm <sup>2</sup>	135 – 171 psi					
		R range	1,294 – 1,638 kPa	13.2 – 16.7 kgf/cm <sup>2</sup>	188 – 238 psi					
Engine stall revolution			2,200 ± 150 rpm							
Time lag	N range → D range		Less than 1.2 seconds							
	N range → R range		Less than 1.5 seconds							
Engine idling speed (A/C OFF)		N range	800 rpm							
Throttle cable adjustment										
Throttle valve fully opened			Between boot end face and inner cable stopper							
			0 – 1 mm		0 – 0.04 in.					
Torque converter sleeve runout		Limit	0.30 mm		0.0118 in.					
Torque converter installation distance			20.0 mm		0.787 in.					
Drive plate runout			0.20 mm		0.0079 in.					
Shift point km/h (mph)			Throttle valve fully open [ ] Fully closed							
			1 → 2	2 → 3	3 → O/D	[3 → O/D]	[O/D → 3]	O/D → 3	3 → 2	2 → 1
	D range	NORM	44–48 (27–30)	93–99 (58–61)	134–141 (83–87)	35–39 (22–24)	21–25 (13–16)	128–135 (79–84)	87–94 (54–58)	40–43 (25–27)
		PWR	47–51 (29–32)	93–99 (58–61)	148–155 (92–96)	50–53 (31–33)	21–25 (13–16)	143–149 (89–92)	87–94 (54–58)	41–45 (25–28)
	2 range	NORM PWR	43–46 (27–29)	103–109 (64–68)	–	–	–	–	97–103 (60–64)	38–42 (24–26)
L range	NORM PWR	–	–	–	–	–	–	82–89 (51–55)	47–51 (29–32)	
Lock-up point km/h (mph)			Throttle valve opening 5%							
			Lock-up ON			Lock-up OFF				
			2nd	*3rd	O/D	2nd	*3rd	O/D		
	D range	NORM	–	41–45 (25–28)	59–63 (37–39)	–	38–42 (24–26)	55–59 (34–37)		
		PWR	–	55–59 (34–37)	75–79 (47–49)	–	50–53 (31–33)	70–73 (43–45)		
		* O/D switch OFF								

## Torque Specifications

(Refer to the A340E automatic transmission)

## TRANSFER (RF1A Type Transfer W56)

### Specifications

Output shaft bearing thrust clearance			Less than 0.10 mm (0.0039 in.)
Output shaft snap ring thickness	Mark		
	0	2.40 – 2.45 mm	0.0945 – 0.0965 in.
	1	2.45 – 2.50 mm	0.0965 – 0.0984 in.
	2	2.50 – 2.55 mm	0.0984 – 0.1004 in.
	3	2.55 – 2.60 mm	0.1004 – 0.1024 in.
	4	2.60 – 2.65 mm	0.1024 – 0.1043 in.
	5	2.65 – 2.70 mm	0.1043 – 0.1063 in.
Output shaft runout	Limit	0.03 mm	0.0012 in.
Output shaft outer diameter	Limit	Part A	44.984 mm 1.7710 in.
		Part B	34.984 mm 1.3773 in.
Low gear to output shaft oil clearance	STD	0.010 – 0.055 mm	0.0004 – 0.0022 in.
	Limit	0.075 mm	0.0030 in.
Low gear thrust clearance	STD	0.10 – 0.25 mm	0.0039 – 0.0098 in.
	Limit	0.30 mm	0.0118 in.
Transfer drive gear to output shaft oil clearance	STD	0.009 – 0.051 mm	0.0004 – 0.0020 in.
	Limit	0.071 mm	0.0028 in.
Transfer drive gear thrust clearance	STD	0.09 – 0.27 mm	0.0035 – 0.0106 in.
	Limit	0.32 mm	0.0126 in.
Input shaft bearing thrust clearance			Less than 0.15 mm (0.0059 in.)
Input shaft snap ring thickness	Mark		
	1	2.05 – 2.10 mm	0.0807 – 0.0827 in.
	3	2.15 – 2.20 mm	0.0846 – 0.0866 in.
	5	2.25 – 2.30 mm	0.0886 – 0.0906 in.
Counter shaft bearing thrust clearance			Less than 0.15 mm (0.0059 in.)
Counter shaft snap ring thickness	Mark		
	1	2.10 – 2.15 mm	0.0827 – 0.0846 in.
	3	2.20 – 2.25 mm	0.0866 – 0.0886 in.
Idler gear shaft bearing thrust clearance			Less than 0.15 mm (0.0059 in.)
Idler gear shaft snap ring thickness	Mark		
	A	1.50 – 1.55 mm	0.0591 – 0.0610 in.
	B	1.60 – 1.65 mm	0.0630 – 0.0650 in.
Shift fork to hub sleeve clearance	Limit	1.0 mm	0.039 in.
Speedometer driven gear oil seal depth		20 mm	0.79 in.
Front drive gear oil seal depth		7 mm	0.28 in.

## Torque Specifications

Part tightened	N·m	kgf·cm	ft·lbf
Adaptor x Reduction gear case	39	400	29
Reduction gear case x Front case x Rear case	39	400	29
Rear case x Extension housing	39	400	29
Front case x Rear case	39	400	29
Reduction case x Front case	39	400	29
Reduction case x Transfer case cover	8.8	90	78 in·lbf
Output shaft x Companion flange	123	1,250	90
Front drive gear bearing retainer x Front case	18	185	13
Front case x Bearing retainer	18	185	13
Straight screw plug	12	120	9
Transfer indicator switch	34	350	25
Speedometer driven gear lock plate	11	115	8

## TRANSFER (VF1A Type Transfer G58 R150F A340F) Specifications

Oil pump body	Body clearance	STD	0.10 – 0.16 mm	0.0039 – 0.0063 in.	
		Limit	0.16 mm	0.0063 in.	
	Tip clearance	STD	0.08 – 0.16 mm	0.0031 – 0.0063 in.	
		Limit	0.16 mm	0.0063 in.	
	Side clearance	STD	0.03 – 0.08 mm	0.0012 – 0.0031 in.	
		Limit	0.08 mm	0.0031 in.	
Rear output shaft assembly	Drive sprocket thrust clearance	STD	0.10 – 0.25 mm	0.0039 – 0.0098 in.	
		Limit	0.25 mm	0.0098 in.	
	Driven sprocket oil clearance	STD	0.010 – 0.055 mm	0.0004 – 0.0022 in.	
		Limit	0.055 mm	0.0022 in.	
	Rear output shaft journal diameter	Limit	Part A	27.98 mm	1.1016 in.
			Part B	36.98 mm	1.4559 in.
	Front drive shift fork to hub sleeve clearance	Limit		1.0 mm	0.039 in.
	High and low shift fork to hub sleeve clearance	Limit		1.0 mm	0.039 in.
	Rear output shaft snap ring thickness	Mark	A	2.10 – 2.15 mm	0.0827 – 0.0846 in.
			B	2.15 – 2.20 mm	0.0846 – 0.0866 in.
			C	2.20 – 2.25 mm	0.0866 – 0.0886 in.
			D	2.25 – 2.30 mm	0.0886 – 0.0906 in.
			E	2.30 – 2.35 mm	0.0906 – 0.0925 in.
F			2.35 – 2.40 mm	0.0925 – 0.0945 in.	
G			2.40 – 2.45 mm	0.0945 – 0.0965 in.	
H			2.45 – 2.50 mm	0.0965 – 0.0984 in.	
	J	2.50 – 2.55 mm	0.0984 – 0.1004 in.		
	K	2.00 – 2.05 mm	0.0787 – 0.0807 in.		
	L	2.05 – 2.10 mm	0.0807 – 0.0827 in.		

## Specifications (Cont'd)

Input shaft	Input shaft journal outer diameter	Limit	47.59 mm	1.8736 in.
	Input shaft bushing diameter	Limit	39.14 mm	1.5409 in.
	Synchronizer ring to sprocket clearance	STD	1.15 – 1.85 mm	0.0453 – 0.0728 in.
		Limit	0.8 mm	0.0031 in.
	Input shaft snap ring thickness	Mark		
		A	2.10 – 2.15 mm	0.0827 – 0.0846 in.
		B	2.15 – 2.20 mm	0.0846 – 0.0866 in.
		C	2.20 – 2.25 mm	0.0866 – 0.0886 in.
		D	2.25 – 2.30 mm	0.0886 – 0.0906 in.
		E	2.30 – 2.35 mm	0.0906 – 0.0925 in.
		F	2.35 – 2.40 mm	0.0925 – 0.0945 in.
		G	2.40 – 2.45 mm	0.0945 – 0.0965 in.
		H	2.45 – 2.50 mm	0.0965 – 0.0984 in.
		J	2.50 – 2.55 mm	0.0984 – 0.1004 in.
		K	2.55 – 2.60 mm	0.1004 – 0.1024 in.
		L	2.60 – 2.65 mm	0.1024 – 0.1043 in.
		M	2.65 – 2.70 mm	0.1043 – 0.1063 in.
		N	2.70 – 2.75 mm	0.1063 – 0.1083 in.
		P	2.75 – 2.80 mm	0.1083 – 0.1102 in.
		Q	2.80 – 2.85 mm	0.1102 – 0.1122 in.
R		2.85 – 2.90 mm	0.1122 – 0.1142 in.	
S	2.90 – 2.95 mm	0.1142 – 0.1161 in.		
T	2.95 – 3.00 mm	0.1161 – 0.1181 in.		
U	3.00 – 3.05 mm	0.1181 – 0.1201 in.		
Planetary gear	Pinion gear thrust clearance	STD	0.11 – 0.86 mm	0.0043 – 0.0339 in.
		Limit	0.86 mm	0.0339 in.
	Pinion gear oil clearance	STD	0.009 – 0.038 mm	0.0004 – 0.0015 in.
		Limit	0.038 mm	0.0015 in.
	Outer bearing snap ring thickness	Mark		
		1	1.45 – 1.50 mm	0.0571 – 0.0591 in.
2		1.50 – 1.55 mm	0.0591 – 0.0610 in.	
3		1.55 – 1.60 mm	0.0610 – 0.0630 in.	
4		1.60 – 1.65 mm	0.0630 – 0.0650 in.	
5	1.65 – 1.70 mm	0.0650 – 0.0669 in.		
Inner bearing depth		5.0 – 5.6 mm	0.197 – 0.220 in.	
Oil seal	Speedometer driven gear oil seal depth		25 mm	0.98 in.
	Shift fork shaft oil seal depth		–0.5 – 0.5 mm	–0.020 – 0.020 in.

## Torque Specifications

Part tightened	N·m	kgf·cm	ft·lbf
Oil pump plate	7.4	75	65 in·lbf
Straight screw plug for oil pump body	29	300	22
Straight screw plug for ring gear	19	190	14
Oil pump body x Front case	11	115	8
Separator with oil strainer	18	185	13
Straight screw plug for shift fork shaft	19	190	14
Front case x Rear case	37	380	27
Extension housing	11	115	8
Companion flange lock nut	118	1,200	87
Control retainer or upper cover	18	185	13
Front retainer	11	115	8
Transfer indicator switch	37	380	27
Transfer assembly x Transmission	37	380	27
Transfer L4 position switch	37	380	27

## TRANSFER (Installation of Transfer)

### Torque Specifications

Part tightened	N·m	kgf·cm	ft·lbf
Transfer x Transfer adaptor			
W56	39	400	29
G 58, R 150F, A340F	37	380	27
Engine rear mounting	25	260	19
Transfer x Dynamic damper	37	380	27
(Regular cab w/ Planetary gear type transfer)			



# PROPELLER SHAFT

## Specifications

Spider axial play			Less than 0.05 mm (0.0020 in.)	
Spider bearing selection		<b>Mark</b>		
Bearing cup outer diameter		<b>None</b>	29.008 – 29.021 mm	1.1420 – 1.1426 in.
		<b>Red</b>	29.028 – 29.041 mm	1.1428 – 1.1433 in.
Bearing hole inner diameter		<b>None</b>	29.000 – 29.020 mm	1.1417 – 1.1425 in.
		<b>Drill</b>	29.021 – 29.042 mm	1.1426 – 1.1434 in.
Snap ring thickness	<b>Color</b>	<b>Mark</b>		
	<b>None</b>	<b>1</b>	2.100 – 2.150 mm	0.0827 – 0.0846 in.
	<b>None</b>	<b>2</b>	2.150 – 2.200 mm	0.0846 – 0.0866 in.
	<b>None</b>	<b>3</b>	2.200 – 2.250 mm	0.0866 – 0.0886 in.
	<b>Brown</b>	<b>None</b>	2.250 – 2.300 mm	0.0886 – 0.0906 in.
	<b>Blue</b>	<b>None</b>	2.300 – 2.350 mm	0.0906 – 0.0925 in.
	<b>None</b>	<b>6</b>	2.350 – 2.400 mm	0.0925 – 0.0945 in.
	<b>None</b>	<b>7</b>	2.400 – 2.450 mm	0.0945 – 0.0965 in.
	<b>None</b>	<b>8</b>	2.450 – 2.500 mm	0.0965 – 0.0984 in.
Runout		<b>Limit</b>	0.8 mm	0.031 in.

## Torque Specifications

Part tightened	N·m	kgf·cm	ft·lbf	
Front differential x Front propeller shaft (4WD)	74	750	54	
Front propeller shaft x Transfer (4WD)	74	750	54	
Propeller shaft x Rear differential	3VZ-E (M/T)	76	780	56
	Ex. 3VZ-E (M/T)	74	750	54
Propeller shaft x Transfer 3VZ-E (M/T)	76	780	56	
	Ex. 3VZ-E (M/T)	74	750	54
Intermediate shaft x Propeller shaft (4WD)	3VZ-E (M/T)	76	780	56
	Ex. 3VZ-E (M/T)	74	750	54
Propeller shaft x Differential (2WD)	74	750	54	
Intermediate shaft x Propeller shaft (2WD)	74	750	54	
Center support bearing x Frame	36	370	27	
Intermediate shaft x Center bearing x Joint flange	181	1,850	134	
	1 st			
	2nd	<b>Loosen nut</b>		
	3rd	69	700	51
Front propeller shaft No. 2 dust cover set bolts	17	175	13	
Front propeller shaft No. 2 dust cover set nut	13	135	10	
(w/ VF 1 A type transfer and A340H)				
Front propeller shaft dust cover subassembly x Bracket	23	230	17	
Front propeller shaft dust cover subassembly x Transfer	37	370	27	
Propeller shaft protector x Frame	29	300	22	

## SUSPENSION AND AXLE

### Specifications (Front/2WD)

Cold tire inflation pressure	Tire size		Pressure		kPa (kgf/cm <sup>2</sup> , psi)
			Front	Rear	
	P195/75R14 P205/75R14 P215/65R15	200 (2.0, 29)		240 (2.4, 35)	
185R14LT-6PR	220 (2.2, 32)		220 (2.2, 32)		
185R14LT-8PR	200 (2.0, 29)		450 (4.5, 65)		
Chassis ground clearance	Model	Tire size	Clearance		mm (in.)
			Front	Rear	
RN80L - TRMDEA RN80L - TRMDEK	P195/75R14	257 (10.12)	263 (10.35)		
RN80L - TRSDEA RN80L - TRSDEK	P195/75R14	257 (10.12)	263 (10.35)		
RN80L - TRMREA RN80L - TRMREK	P195/75R14	260 (10.23)	268 (10.55)		
RN85L - TRMDEA RN85L - TRMDEK	P195/75R14	263 (10.35)	261 (10.28)		
RN85L - TRSDEA RN85L - TRSDEK	P195/75R14	262 (10.31)	261 (10.28)		
RN90L - CRMDEA RN90L - CRMDEK	P205/75R14	278 (10.94)	264 (10.39)		
RN90L - CRSDEA RN90L - CRSDEK	P205/75R14	278 (10.94)	264 (10.39)		
VZN85L - THMDEA	185R14LT - 8PR	260 (10.24)	284 (11.18)		
VZN85L - THSDEA	185R14LT - 8PR	258 (10.16)	283 (11.14)		
VZN85L - TWMREA6	185R14LT - 6PR	259 (10.20)	234 (9.21)		
VZN85L - TINSREA6	185R14LT - 6PR	259 (10.24)	235 (9.25)		
VZN90L - CRMDEA VZN90L - CRMDEK	P205/75R14	277 (10.91)	266 (10.47)		
VZN90L - CRSDEA VZN90L - CRSDEK	P205/75R14	277 (10.91)	265 (10.43)		
VZN90L - CRMGEA	P205/75R14	273 (10.75)	262 (10.31)		
VZN90L - CRPGEA	P205/75R14	273 (10.75)	262 (10.31)		
	P215/75R15	274 (10.79)	263 (10.35)		
VZN95L - TWMREA6	185R14LT - 6PR	259 (10.20)	232 (9.13)		
VZN95L - TWSREA6 VZN95L - TWSREK6	185R14LT - 6PR	259 (10.20)	232 (9.13)		
Front wheel alignment	Model	Camber	Caster	Steering axis inclination	Toe-in mm (in.)
	RN80L - TRSDEA RN80L - TRSDEK	0°30' ± 45'	0°43' ± 45'	10°00' ± 45'	1.32 ± 2 (0.0520 ± 0.08)
	RN80L - TRMDEA RN80L - TRMDEK	0°30' ± 45'	0°44' ± 45'	10°00' ± 45'	1.32 ± 2 (0.0520 ± 0.08)
	RN80L - TRMREA RN80L - TRMREK	0°28' ± 45'	0°40' ± 45'	10°01' ± 45'	1.74 ± 2 (0.0685 ± 0.08)

## Specifications (Front/2WD) (Cont'd)

Front wheel alignment (cont'd)	Model	Camber	Caster	Steering axis inclination	Toe-in mm (in.)
	RN85L – TRMDEA RN85L – TRMDEK	0°27' ± 45'	0°59' ± 45'	10°02' ± 45'	2.09±2 (0.0822±0.08)
	RN85L – TRSDEA RN85L – TRSDEK	0°27' ± 45'	0°58' ± 45'	10°02' ± 45'	2.09±2 (0.0822±0.08)
	RN90L – CRSDEA RN90L – CRSDEK	0°23' ± 45'	1°15' ± 45'	10°06' ± 45'	3.27±2 (0.1287±0.08)
	RN90L – CRMDEA RN90L – CRMDEK	0°23' ± 45'	1°15' ± 45'	10°06' ± 45'	3.27±2 (0.1287±0.08)
	VZN85L – THMDEA	0°29' ± 45'	0°34' ± 45'	10°00' ± 45'	5.61±2 (0.2209±0.08)
	VZN85L – THSDEA	0°30' ± 45'	0°33' ± 45'	10°00' ± 45'	4.85±2 (0.1909±0.08)
	VZN85L – TWMREA6	0°29' ± 45'	1°46' ± 45'	10°00' ± 45'	5.73±2 (0.2256±0.08)
	VZN85L – TWSREA6	0°29' ± 45'	1°45' ± 45'	10°00' ± 45'	5.73±2 (0.2256±0.08)
	VZN90L – CRMDEA VZN90L – CRMDEK	0°23' ± 45'	1°11' ± 45'	10°06' ± 45'	3.27±2 (0.1287±0.08)
	VZN90L – CRSDEA VZN90L – CRSDEK	0°23' ± 45'	1°12' ± 45'	10°06' ± 45'	3.27±2 (0.1287±0.08)
	VZN90L – CRMGEA	0°25' ± 45'	1°13' ± 45'	10°04' ± 45'	2.82±2 (0.1110±0.08)
	VZN90L – CRPGEA	0°25' ± 45'	1°12' ± 45'	10°04' ± 45'	2.82±2 (0.1110±0.08)
	VZN95L – T1IVMREA6	0°29' ± 45'	1°47' ± 45'	10°00' ± 45'	5.73±2 (0.2256±0.08)
	VZN95L – TWSREA6 VZN95L – TWSREK6	0°29' ± 45'	1°46' ± 45'	10°00' ± 45'	5.73±2 (0.2256±0.08)
	Wheel angle	Max. Inside wheel Outside wheel At 20° (outside wheel)	34° +1° -2° 30° 22°15' (Inside wheel)		
Disc wheel lateral runout	Limit	1.2 mm 0.047 in.			
Wheel bearing preload (starting) (rotating load at hub bolt)	Limit	5.9 – 17.7 N 0.6 – 1.8 kgf 1.3 – 4.0 lbf Add oil seal frictional force			
Hub axial play	Limit	0.05 mm 0.0020 in.			
Lower ball joint vertical play	Limit	0 mm 0 in.			
Upper ball joint vertical play	Limit	2.3 mm 0.091 in.			
Ball joint rotation condition	Lower ball joint Upper ball joint	0.1–4.9 N·m 1–50 kgf·cm 1–43 in.·lbf 2.0–3.9 N·m 20–40 kgf·cm 17–35 in.·lbf			

## Specifications (Front/4WD)

Cold tire inflation pressure	Tire size		Pressure		kPa (kgf/cm <sup>2</sup> , psi)
			Front	Rear	
		<b>P225/75R15</b>		<b>180 (1.8, 26)</b>	
	<b>31X10.5 R15LT</b>		<b>180 (1.8, 26)</b>		<b>200 (2.0, 29)</b>
Front wheel alignment  Specifications with vehicle height set to standard height	Standard vehicle height for alignment inspection	Difference between the height at center of tip of drive shaft and the height at center of tip of front side adjusting cam bolt			58.5 mm (2.303 in.)
		Difference between the height of center of rear leaf spring front bushing and the height of center of rear axle shaft			61.0 mm (2.402 in.)
	Camber		Left-right error		0°45' ± 45' 30' or less
	Caster		Left-right error		2°30' ± 45' 30' or less
	Steering axis inclination		Left-right error		11°50' ± 45' 30' or less
	Toe-in				1 ± 2 mm (0.04 ± 0.08 in.)
	Wheel angle		Max. Inside wheel Outside wheel At 20° (outside wheel)		32°00' +1° -2° 31° 21°10' (inside wheel)
Front wheel alignment  (Specifications at vehicle height of non-loaded vehicle)	Vehicle height of non-loaded vehicle	Model	Tire size	Height mm (in.)	
				Front Height at center of tip of front side adjusting cam bolt	Rear Height of center of rear leaf spring front bushing
		RN101 L - TRLDEA RN101 L - TRLDEK	P225/75R15	281.6 (11.087)	426.9 (16.807)
		RN101 L - TRMDEA	P225/75R15	281.8 (11.095)	426.9 (16.807)
		RN101 L - TRPDEA	P225/75R15	281.4 (11.079)	424.9 (16.728)
		RN106L - TRMDEA	P225/75R15	285.9 (11.256)	427.5 (16.831)
		RN106L - TRMDEA RN106L - TRLDEK	P225/75R15	285.6 (11.244)	427.5 (16.831)
		RN110L - CRMDEA	P225/75R15	292.0 (11.496)	423.2 (16.661)
		RN110L - CRPDEA	P225/75R15	291.4 (11.472)	420.2 (16.543)
		RN110L - CRLDEA	P225/75R15	291.3 (11.468)	423.1 (16.657)
		RN110L - CRLDEK	P225/75R15	291.1 (11.461)	426.4 (16.787)
		VZN100L - TRMDEA VZN100L - TRMDEK	P225/75R15 31X10.5R15LT	279.5 (11.003) 311.0 (12.244)	422.5 (16.634) 454.1 (17.878)
		VZN105L - TRMDEA VZN105L - TRMDEK	P225/75R15 31X10.5R15LT	283.6 (11.165) 315.1 (12.405)	422.6 (16.638) 454.3 (17.886)
		VZN110L - CRMDEA	P225/75R15 31X10.5R15LT	289.8 (11.409) 321.3 (12.650)	418.8 (16.448) 450.4 (17.732)
		VZN110L - CRMDEK	P225/75R15 31X10.5R15LT	289.8 (11.409) 321.3 (12.650)	422.1 (16.618) 453.4 (17.850)
		VZN110L - CRPDEA	P225/75R15 31X10.5R15LT	289.4 (11.394) 321.0 (12.638)	417.4 (16.433) 449.0 (17.677)

## Specifications (Front/4WD) (Cont'd)

Front wheel alignment  Specifications at vehicle height of non-loaded vehicle	Vehicle height of non-loaded vehicle	Model	Tire size	Height mm (in.)					
				Front Height at center of tip of front side adjusting cam bolt	Rear Height of center of rear leaf spring front bushing				
	Alignment	VZN110L - CRPDEK	P225/75R15			289.2 (11.386)	420.6 (16.559)		
			31X10.5R15LT			320.7 (12.626)	452.3 (17.807)		
		VZN110L - CRMGEA	P225/75R15			283.1 (11.146)	415.6 (16.362)		
			10.5R15LT			314.7 (12.390)	447.3 (17.610)		
		VZN110L - CRMGEK	P225/75R15			282.9 (11.138)	418.8 (16.488)		
			31X10.5R15LT			314.4 (12.378)	450.5 (17.736)		
		VZN110L - CRPGEA	P225/75R15			282.7 (11.130)	413.9 (16.296)		
		VZN110L - CRPGEK	31X10.5R15LT			314.3 (12.374)	445.6 (17.543)		
			Model	Camber	Caster	Steering axis inclination	Toe-in mm (in.)		
			RN106L series	0°42' ± 45'	1°41' ± 45'	11°53' ± 45'	2.22 ± 2 (0.0874 ± 0.08)		
		VZN100L series	0°43' ± 45'	1°41' ± 45'	11°52' ± 45'	1.91 ± 2 (0.0751 ± 0.08)			
		VZN105L series	0°42' ± 45'	1°45' ± 45'	11°53' ± 45'	2.22 ± 2 (0.0874 ± 0.08)			
		RN101L - TRMDEA	0°43' ± 45'	1°38' ± 45'	11°52' ± 45'	1.92 ± 2 (0.0756 ± 0.08)			
		RN101L - TRLDEA	0°43' ± 45'	1°38' ± 45'	11°52' ± 45'	1.92 ± 2 (0.0756 ± 0.08)			
		RN101L - TRLDEK	0°43' ± 45'	1°37' ± 45'	11°52' ± 45'	1.92 ± 2 (0.0756 ± 0.08)			
		RN101L - TRPDEA	0°43' ± 45'	1°41' ± 45'	11°52' ± 45'	1.91 ± 2 (0.0752 ± 0.08)			
		RN110L - CRMDEA	0°40' ± 45'	1°49' ± 45'	11°55' ± 45'	2.69 ± 2 (0.1059 ± 0.08)			
		RN110L - CRPDEA	0°40' ± 45'	1°52' ± 45'	11°55' ± 45'	2.69 ± 2 (0.1059 ± 0.08)			
		RN110L - CRLDEA	0°40' ± 45'	1°49' ± 45'	11°55' ± 45'	2.68 ± 2 (0.1055 ± 0.08)			
	RN110L - CRLDEK	0°40' ± 45'	1°44' ± 45'	11°55' ± 45'	2.68 ± 2 (0.1055 ± 0.08)				
	VZN110L - CRMDEA	0°40' ± 45'	1°52' ± 45'	11°55' ± 45'	2.69 ± 2 (0.1059 ± 0.08)				
	VZN110L - CRMDEK	0°40' ± 45'	1°48' ± 45'	11°55' ± 45'	2.69 ± 2 (0.1059 ± 0.08)				
	VZN110L - CRPDEA	0°40' ± 45'	1°53' ± 45'	11°55' ± 45'	2.69 ± 2 (0.1059 ± 0.08)				
	VZN110L - CRPDEK	0°40' ± 45'	1°49' ± 45'	11°55' ± 45'	2.69 ± 2 (0.1059 ± 0.08)				
	VZN110L - CRMGEA	0°42' ± 45'	1°55' ± 45'	11°53' ± 45'	2.25 ± 2 (0.0886 ± 0.08)				
	VZN110L - CRMGEK	0°42' ± 45'	1°50' ± 45'	11°53' ± 45'	2.25 ± 2 (0.0886 ± 0.08)				
	VZN110L - CRPGEA	0°42' ± 45'	1°56' ± 45'	11°53' ± 45'	2.25 ± 2 (0.0886 ± 0.08)				
	Camber left-right error			30' or less					
	Caster left-right error			30' or less					
	Steering axis inclination left-right error			30' or less					
	Wheel angle	Max.	Inside wheel	32°00' + 1°					
			Outside wheel	- 2°					
		At 200	(outside wheel)	21°10' (inside wheel)					
Disc wheel lateral runout Limit			1.2 mm	0.047 in.					
Wheel bearing preload (starting) (rotating load at hub bolt)			28 - 56 N	2.9 - 5.7 kgf	6.4 - 12.6 lbf				
Free wheeling hub ring oil clearance			0.3 mm	0.012 in.					
Automatic locking hub brake shoe thickness			1.5 mm	0.059 in.					
Front drive shaft thrust clearance	Minimum			0.075 - 0.690 mm	0.0030 - 0.0272 in.				
	Maximum			1.0 mm	0.039 in.				

## Specifications (Front/4WD) (Cont'd)

Front drive shaft thrust clearance adjusting shim thickness		1.80 mm 2.25 mm	0.0709 in. 0.0886 in.
Front drive shaft grease capacity			
	Outboard joint (black)	195 – 205 g	0.43 – 0.45 lb
	Inboard joint (brown)	270 – 280 g	0.60 – 0.62 lb
Front differential drive pinion bearing preload (starting)			
	New bearing	1.2 – 1.9 N·m 12 – 19 kgf·cm	10.4 – 16.5 in.·lbf
	Reused bearing	0.6 – 1.0 N·m 6 – 10 kgf·cm	5.2 – 8.7 in.·lbf
Front differential companion flange deviation			
	Maximum vertical runout	0.10 mm	0.0039 in.
	Maximum lateral runout	0.10 mm	0.0039 in.
Front differential ring gear runout		0.07 mm	0.0028 in.
Front differential ring gear backlash		0.13 – 0.18 mm	0.0051 – 0.0071 in.
Front differential preload (starting).	Total preload	Add drive pinion preload	
		0.4 – 0.6 N·m 4 – 6 kgf·cm	3.5 – 5.2 in.·lbf
Front differential side gear backlash		0.05 – 0.20 mm	0.0020 – 0.0079 in.
Front differential rear oil seal drive in depth		1.5 mm	0.059 in.
Clutch sleeve clearance (A.D.D.)	Limit	0.35 mm	0.0138 in.
Nut tightening limit		70 mm	3.43 in.
Lower ball joint vertical play		2.3 mm	0.091 in.
Upper ball joint vertical play	Limit	0 mm	0 in.
Lower ball joint turning torque		0.1 – 4.9 N·m 1 – 50 kgf·cm	1 – 43 in.·lbf
Upper ball joint turning torque		2.0 – 3.9 N·m 20 – 40 kgf·cm	17 – 35 in.·lbf

## Specifications (Rear)

Rear axle shaft (Single tire)	Maximum shaft runout	2.0 mm	0.079 in.	
	Maximum flange runout	0.2 mm	0.008 in.	
Rear axle shaft and hub (Double tire)	Maximum shaft runout	2.0 mm	0.079 in.	
	Preload (starting)	Add oil seal frictional force 1.0 – 14.7 N 0.1 – 1.5 kgf 0.2 – 3.3 lbf		
7.5 in. differential	Drive pinion bearing preload (starting)			
		New bearing	1.2 – 1.9 N·m 12 – 19 kgf·cm 10.4 – 16.5 in.·lbf	
		Reused bearing	0.6 – 1.0 N·m 6 – 10 kgf·cm 5.2 – 8.7 in.·lbf	
	Total preload (starting)		Add drive pinion bearing preload	
		New and reused bearing	0.4 – 0.6 N·m 4 – 6 kgf·cm	3.5 – 5.2 in.·lbf
	Drive pinion to ring gear backlash	0.13 – 0.18 mm	0.0051 – 0.0071 in.	
	Pinion gear to side gear backlash	0.05 – 0.20 mm	0.0020 – 0.0079 in.	
	Ring gear runout	0.07 mm	0.0028 in.	
Companion flange deviation				
	Maximum vertical runout	0.10 mm	0.0039 in.	
	Maximum lateral runout	0.10 mm	0.0039 in.	
8.0 in. differential	Drive pinion bearing preload (starting)			
	2 pinion type	New bearing	1.9 – 2.5 N·m 19 – 26 kgf·cm 16.5 – 22.6 in.·lbf	
		Reused bearing	0.9 – 1.3 N·m 9 – 13 kgf·cm 7.8 – 11.3 in.·lbf	
	4 pinion type	New bearing	1.0 – 1.6 N·m 10 – 16 kgf·cm 8.7 – 13.9 in.·lbf	
	Reused bearing	0.5 – 0.8 N·m 5 – 8 kgf·cm	4.3 – 6.9 in.·lbf	

## Specifications (Rear) (Cont'd)

8.0 in. differential (cont'd)	Total preload (starting)	Add drive pinion bearing preload		
		0.4 – 0.6 N·m	4 – 6 kgf·cm	3.5 – 5.2 in.·lbf
	Drive pinion to ring gear backlash	0.13 – 0.18 mm	0.0051 – 0.0071 in.	
	Pinion gear to side gear– backlash	0.05 – 0.20 mm	0.0020 – 0.0079 in.	
	Ring gear runout	Limit	0.10 mm	0.0039 in.
	Companion flange deviation			
	Maximum vertical runout	0.10 mm	0.0039 in.	
	Maximum lateral runout	0.10 mm	0.0039 in.	

## Torque Specifications (Front/2WD)

Part tightened	N·m	kgf·cm	ft·lbf
Knuckle stopper bolt lock nut	34	350	25
Tie rod clump bolt	22	225	16
Steering knuckle x Upper ball joint	108	1,100	80
Steering knuckle x Lower ball joint	142	1,450	105
Steering knuckle x Tie rod	90	920	67
Upper suspension arm x Upper ball joint	31	320	23
Lower suspension arm x Lower ball joint	127	1,300	94
Torsion bar spring lock nut	83	850	61
Lower suspension arm x Strut bar	95	970	70
Lower suspension arm x Stabilizer bar	13	130	9
Lower suspension arm x Shock absorber	18	185	13
Shock absorber x Frame	25	250	18
Lower arm shaft nut	226	2,300	166
Upper arm shaft x Frame	96	980	71
Upper suspension arm set bolt	126	1,280	93
Strut bar x Frame	123	1,250	90
Stabilizer bar bracket x Frame	29	300	22
Hub nut	103	1,050	76

## Torque Specifications (Front/4WD)

Part tightened	N·m	kgf·cm	ft·lbf
Knuckle stopper bolt lock nut	47	480	35
Free wheeling hub body x Axle hub	31	315	23
Free wheeling hub body x Front drive shaft	18	185	13
Free wheeling hub body x Cover	10	100	7
Axle hub bearing lock nut	47	480	35
Upper suspension arm x Upper ball joint	33	340	25
Upper ball joint x Steering knuckle	142	1,450	105
Steering knuckle arm x Steering knuckle	183	1,870	135
Lower suspension arm x Shock absorber	137	1,400	101
Lower suspension arm x Stabilizer bar	25	260	19
Lower suspension arm x Lower ball joint	142	1,450	105
Front drive shaft x Side gear shaft	83	845	61
Front differential front mounting bolt	147	1,500	108
Front differential rear left mounting bolt	167	1,700	123

## Torque Specifications (Front/4WD) (Cont'd)

Part tightened	N·m	kgf·cm	ft·lbf
Front differential rear right mounting bolt	167	1,700	123
Differential tube x Bracket	127	1,300	94
Front differential x Bracket	78	800	58
Ring gear x Differential case	97	985	71
Differential carrier x Differential tube (w/o A.D.D.) Differential carrier x Side bearing cap	85	900	65
Differential carrier x Carrier cover	78	800	58
Differential carrier x Carrier cover	47	475	34
Lower suspension arm x Frame	196	2,000	145
Upper suspension arm shaft x Frame	178	1,810	131
A.D.D. clutch case x Differential carrier	78	800	58
A.D.D. clutch case x Differential to be	78	800	58
A.D.D. clutch case cover x A.D.D. clutch case	21	210	15
Upper suspension arm shaft lock nut	226	2,300	166
Upper suspension arm x Torque arm	87	890	64
Shock absorber x Frame	25	250	18
Stabilizer bar bracket x Frame	29	300	22
Hub nut	103	1,050	76

## Torque Specifications (Rear)

Part tightened	N·m	kgf·cm	ft·lbf
Ring gear x Differential case	97	985	71
Bearing cap x Differential carrier	78	800	58
Differential carrier x Axle housing	25	250	18
	31	315	23
	69	700	51
Rear axle housing x Bearing retainer	69	700	51
Spring center bolt	44	450	33
Front spring bracket x Hanger pin			
Rubber bushing type	91	930	67
Press-installed bushing type	157	1,600	116
Rear spring shackle x Leaf spring	91	930	67
Rear shock absorber x U-bolt seat	25	260	19
	72	730	53
Rear shock absorber x Body	25	260	19
	72	730	53
U-bolt x U-bolt seat			
2WD	147	1,500	108
0.5 ton	123	1,250	90
1 ton, C & C	123	1,250	90
4WD	147	1,500	108
Xtra cab	147	1,500	108
Regular cab	147	1,500	108
Stabilizer bar x Stabilizer bar link	36	365	26
Stabilizer bar bracket x Axle housing	13	130	9
Hub nut	103	1,050	76



# BRAKE SYSTEM

## Specifications

Brake pedal	Pedal height (from asphalt sheet)				
		2WD	148 - 153 mm	5.83 - 6.02 in.	
		4WD	145 - 150 mm	5.71 - 5.91 in.	
	Stop light switch to pedal clearance		0.5 - 2.4 mm	0.02 - 0.09 in.	
	Pedal freeplay		3 - 6 mm	0.12 - 0.24 in.	
	Pedal reserve distance				
	at 490 N (50 kgf, 110.2 lbf)				
	2WD	22R-E engine	More than 70 mm (2.76 in.)		
		3VZ-E engine			
		1 ton	More than 75 mm (2.95 in.)		
		1/2 ton	More than 65 mm (2.56 in.)		
		C & C			
		SRW	More than 75 mm (2.95 in.)		
		DRW	More than 55 mm (2.17 in.)		
	4WD		More than 65 mm (2.56 in.)		
Brake booster	Booster push rod piston clearance				
		w/ SST	0 mm	0 in.	
Front disc brake	<b>PD 60, 66 type</b>				
	Disc thickness				
		PD 60 type	STD	25.0 mm	0.984 in.
			Limit	23.0 mm	0.906 in.
		PD 66 type	STD	30.0 mm	1.181 in.
			Limit	28.0 mm	1.102 in.
	Disc runout				
		PD 60 type	Limit	0.09 mm	0.0035 in.
		PD 66 type	Limit	0.12 mm	0.0047 in.
	Pad thickness				
		PD 60 type	STD	9.5 mm	0.374 in.
			Limit	1.0 mm	0.039 in.
		PD 66 type	STD	9.7 mm	0.382 in.
			Limit	1.0 mm	0.039 in.
	<b>FS 17, 18 type</b>				
	Disc thickness		STD	22.0 mm	0.866 in.
			Limit	20.0 mm	0.787 in.
	Disc runout		Limit	0.09 mm	0.0035 in.
	Pad thickness				
		FS 17 type	STD	9.5 mm	0.374 in.
			Limit	1.0 mm	0.039 in.
		FS 18 type	STD	10.0 mm	0.394 in.
			Limit	1.0 mm	0.039 in.
<b>S12 + 12 type</b>					
Disc thickness		STD	20.0 mm	0.787 in.	
		Limit	18.0 mm	0.709 in.	
Disc runout		Limit	0.09 mm	0.0035 in.	
Pad thickness		STD	9.5 mm	0.374 in.	
		Limit	1.5 mm	0.059 in.	

## Specifications (Cont'd)

Rear brake	2WD Drum inner diameter	STD	254.0 mm	10.000 in.
		Limit	256.0 mm	10.079 in.
	Lining thickness	STD	5.0 mm	0.197 in.
		Limit	1.0 mm	0.039 in.
	4WD Drum inner diameter	STD	295.0 mm	11.614 in.
		Limit	297.0 mm	11.693 in.
		STD	6.0 mm	0.236 in.
		Limit	1.0 mm	0.039 in.
Parking brake	2W D	1/2 ton	12 - 18 clicks	
		1 ton	11 - 17 clicks	
	4WD	11 - 17 clicks		

## Torque Specifications

Part tightened	N·m	kgf·cm	ft·lbf
Master cylinder x Piston stopper bolt	10	100	7
Master cylinder x Reservoir	1.7	17.5	15.2 in.·lbf
Master cylinder x Brake booster	13	130	9
Brake tube union nut	15	155	11
Brake booster clevis lock nut	25	260	19
Brake booster x Pedal bracket	13	130	9
Front brake wheel cylinder x Backing plate	18	185	13
Front brake cylinder installation bolt (PD 60, 66 type disc)	39	400	29
Front brake cylinder sliding pin (FS 17, 18 type disc)	88	900	65
Torque plate x Steering knuckle	108	1,100	80
2WD		1,250	90
4WD			
Rear brake wheel cylinder x Backing plate	10	100	7
Leading-trailing type			
Duo-servo type			
Bleeder plug	14	145	10
LSP & BV (LSPV) bracket x Frame	11	110	8
LSP & BV (LSPV) x LSP & BV (LSPV) bracket	19	195	14
LSP & BV (LSPV) spring x LSP & BV (LSPV) bracket	13	130	9
LSP & BV (LSPV) spring x Shackle	18	185	13
LSP & BV (LSPV) shackle lock nut	18	185	13
LSP & BV (LSPV) shackle x Shackle bracket	25	250	18
LSP & BV (LSPV) shackle bracket x Rear axle housing	13	130	9
Brake actuator x PS pressure line	19	195	14
Brake actuator x Actuator bracket	47	475	34
Actuator bracket x Frame	13	130	9
Speed sensor x Rear differential	28	290	21
Speed sensor wire harness x Clamp bracket	19	195	14
Clamp bracket x Rear differential	19	195	14
Deceleration sensor x Body	5.4	55	48 in.·lbf

# STEERING

## Specifications

Steering column	Steering wheel freeplay Pawl stopper	Maximum Mark	30 mm	1.18 in.
		1 or A	12.65 - 12.75 mm	0.4980 - 0.5020 in.
		2 or B	12.55 - 12.65 mm	0.4941 - 0.4980 in.
		3 or C	12.45 - 12.55 mm	0.4902 - 0.4941 in.
		4 or D	12.35 - 12.45 mm	0.4862 - 0.4902 in.
		5 or E	12.25 - 12.35 mm	0.4823 - 0.4862 in.
Manual gear housing	Sector shaft thrust clearance		0.05 mm	0.0020 in.
	Thrust washer thickness (2WD)		1.95 mm	0.0768 in.
			2.00 mm	0.0787 in.
			2.05 mm	0.0807 in.
			2.10 mm	0.0827 in.
			2.15 mm	0.0847 in.
	Thrust washer thickness (4WD)		1.95 mm	0.0768 in.
			2.00 mm	0.0787 in.
			2.05 mm	0.0807 in.
	Worm bearing preload (2WD) at Starting		0.3 - 0.5 N·m 3 - 5 kgf·cm	2.6 - 4.3 in.·lbf
(4WD) at Starting		0.3 - 0.5 N·m 3.5 - 5 kgf·cm	3.0 - 4.3 in.·lbf	
Total preload (2WD) at Starting		0.8 - 1.0 N·m 8 - 10.5 kgf·cm	6.9 - 9.1 in.·lbf	
	(4WD) at Starting		0.8 - 1.1 N·m 8 - 11.0 kgf·cm	6.9 - 9.5 in.·lbf
Sector shaft end cover bushing inside diameter (4WD)	Maximum	36.07 mm	1.4201 in.	
Power steering	Drive belt tension	New belt	441 - 667 N·m	45 - 68 kgf 100 - 150 lbf
		Used belt	265 - 441 N·m	27 - 45 kgf 60 - 100 lbf
	Maximum rise of oil level		5 mm	0.20 in.
	Oil pressure at idle speed	Minimum	7,335 kPa	75 kgf/cm <sup>2</sup> 1,067 psi
	Steering effort (w/o PPS)	Maximum	39 N	4 kgf 8.8 lbf
		(w/ PPS) Maximum	29 N	3 kgf 6.6 lbf
	Rotor shaft bushing oil clearance	STD	0.01 - 0.03 mm	0.0004 - 0.0012 in.
		Maximum	0.07 mm	0.0028 in.
	Rotor to cam ring oil clearance (RN series)	Maximum	0.06 mm	0.0024 in.
	Vane plate to rotor groove clearance			
		Maximum	0.03 mm	0.0012 in.
	Vane plate	Minimum length	14.988 mm	0.5901 in.
		Minimum height	8.1 mm	0.319 in.
		Minimum thickness	1.797 mm	0.0707 in.
	Vane plate length	Rotor and cam ring mark		
		None	14.996 - 14.998 mm	0.59039 - 0.59047 in.
1		14.994 - 14.996 mm	0.59032 - 0.59039 in.	
2		14.992 - 14.994 mm	0.59024 - 0.59032 in.	
3		14.990 - 14.992 mm	0.59016 - 0.59024 in.	
4	14.988 - 14.990 mm	0.59008 - 0.59016 in.		

## Specifications (Cont'd)

Power steering (cont'd)	Flow control valve spring length				
		STD	37 mm	1.46 in.	
		Minimum	35 mm	1.38 in.	
	Pump rotating torque	Maximum	0.3 N·m	2.8 kgf·cm	2.4 in.·lbf
	Worm gear valve body ball clearance		0.15 mm	0.0059 in.	
	Cross shaft adjusting screw thrust clearance		0.03 – 0.05 mm	0.0012 – 0.0020 in.	
	Worm gear preload	at Starting	0.3 – 0.5 N·m	3 – 5.5 kgf·cm	2.6 – 4.8 in.·lbf
Total preload	at Starting	0.5 – 0.9 N·m	5 – 9.5 kgf·cm	4.3 – 8.3 in.·lbf	

## Torque Specifications

Steering column	Part tightened	N·m	kgf·cm	ft·lbf
	Steering wheel set nut	34	350	25
	Column tube x Body	25	260	19
	Breakaway bracket x Body	25	260	19
	Column hole cover x Body	7.8	80	69 in.·lbf
	Main shaft x Intermediate shaft	35	360	26
	Intermediate shaft x Worm shaft	35	360	26
	Turn signal bracket x Upper column tube	7.8	80	69 in.·lbf
	Tilt pawl set nut	5.9	60	52 in.·lbf
	Compression spring set bolt	7.8	80	69 in.·lbf
	Tilt lever retainer set nut	15	150	11
	Protector x Breakaway bracket	19	195	14
	Tilt lever assembly installation bolt	2.0	20	17 in.·lbf
Manual gear housing	<b>[2WD]</b>			
	Gear housing x Body	118	1,200	87
	Intermediate shaft x Worm shaft	35	360	26
	Relay rod x Pitman arm	90	920	67
	Pitman arm x Sector shaft	123	1,250	90
	Worm bearing adjusting screw lock nut	109	1,110	80
	End cover set bolt	18	185	13
	Sector shaft adjusting screw lock nut	27	275	20
	Bleeder plug	7.4	75	65 in.·lbf
	<b>[4WD]</b>			
	Gear housing x Body	142	1,450	105
	Intermediate shaft x Worm shaft	35	360	26
	Pitman arm x Sector shaft	177	1,800	130
	Relay rod x Pitman arm	90	920	67
	Worm bearing adjusting screw lock nut	109	1,110	80
	End cover set bolt	93	1,000	72
	Sector shaft adjusting screw lock nut	44	450	33
Bleeder plug	20	200	14	

## Torque Specifications (Cont'd)

Power steering (PS pump)	Part tightened	N·m	kgf·cm	ft·lbf
	Pressure tube x PS pump (RN series/4WD )	36	370	27
	Return hose clamp (RN series)	1.5	15	13 in.·lbf
	(VZN series)	3.9	40	35 in.·lbf
	Pressure tube union bolt	47	475	34
	Pulley set nut	43	440	32
	PS pump x Bracket (RN series)	39	400	29
	(VZN series) Through bolt	58	590	43
	Adjusting bolt	39	400	29
	PS pump x Adjusting stay (VZN series)	41	420	30
	Reservoir tank x PS pump (VZN series)			
	12 mm bolt	13	130	9
	14 mm bolt	41	420	30
	Suction port union (RN series)	13	130	9
	Air control valve	36	370	27
	Pressure port union	69	700	51
	Front housing x Rear housing (RN series)	46	470	34
Power steering (Gear housing)	Pressure tube	44	450	33
	Return tube Union bolt	47	475	34
	Others	49	500	36
	Return hose clamp 4WD	3.9	40	35 in.·lbf
	Intermediate shaft x Worm shaft	35	360	26
	Gear housing x Body 2WD	118	1,200	87
	4WD	142	1,450	105
	Pitman arm x Cross shaft	177	1,800	130
	Cross shaft adjusting screw set nut	46	470	34
	Cross shaft end cover set bolt	46	470	34
	Bleeder plug	7.8	80	69 in.·lbf
	Plunger guide nut	20	205	15
	Worm gear valve body set bolt	46	470	34
	Solenoid valve set bolt (wl PPS)	10	100	7
Steering linkage (2WD)	Pitman arm x Sector shaft MS	123	1,250	90
	PS	177	1,800	130
	Pitman arm x Relay rod	90	920	67
	Tie rod tube clamp bolt	25	260	19
	Tie rod x Relay rod	90	920	67
	Tie rod x Knuckle arm	90	920	67
	Relay rod x Idler arm	59	600	43
	Knuckle arm x Steering knuckle	108	1,100	80
	Steering damper x Frame	13	130	9
	Steering damper x Relay rod	59	600	43
	Idler arm x Idler arm bracket	78	800	58
	Idler arm bracket x Frame	118	1,200	87

## Torque Specifications (Cont'd)

Steering linkage (4WD)	Part tightened	N·m	kgf·cm	ft·lbf
	Pitman arm x Sector shaft	177	1,800	130
	Pitman arm x Relay rod	90	920	67
	Tie rod tube clamp bolt	25	260	19
	Tie rod x Relay rod	90	920	67
	Tie rod x Knuckle arm	90	920	67
	Relay rod x Idler arm	59	600	43
	Relay rod x Steering damper	59	600	43
	Knuckle arm x Steering knuckle	183	1,870	135
	Idler arm x Idler arm bracket	78	800	58
	Idler arm bracket x Frame	142	1,450	105

## BODY

### Torque Specifications

Part tightened	N·m	kgf·cm	ft·lbf
<b>MOON ROOF</b>			
Removable roof hinge case x Body	3.4	35	30 in·lbf
Removable roof lock base x Body	5.9	60	52 in·lbf
Removable roof hinge x Removable roof	2.9	30	26 in·lbf
Removable roof handle x Removable roof	2.9	30	26 in·lbf
<b>ONE-TOUCH TAIL GATE</b>			
Tail gate stay x Tail gate	14	140	10
<b>SEAT</b>			
<b>Front Seat</b>			
Seat adjuster x Body	37	375	27
<b>Rear Jump Seat (Extra Cab)</b>			
Back panel trim x Body	4.9	50	43 in·lbf
Seat cushion x Body	4.9	50	43 in·lbf
<b>SEAT BELT</b>			
Seat belt anchor x Body	43	440	32
Seat belt guide x Body	43	440	32
Buckle x Body	43	440	32

## LUBRICANT

Item		Capacity			Classification
		Liters	U S qts	Imp. qts	
Manual transmission oil					
2W D	G57	2.2	2.3	1.9	API GL-4 or GL-5 SAE 75W-90
	R 150	3.0	3.2	2.6	API GL-4 or GL-5 SAE 75W-90
4WD	G58	3.9	4.1	3.4	API GL-4 or GL-5 SAE 75W-90
	R 150F	3.0	3.2	2.6	
Automatic transmission fluid					ATF DEXRON 11
A43D	Dry fill	6.5	6.9	5.7	
	Drain and refill	2.4	2.5	2.1	
A340E	Dry fill	7.2	7.6	6.3	
	Drain and refill	1.6	1.7	1.4	
A340H					
(Transmission)	Dry fill	10.3	10.9	9.1	
	Drain and refill	4.5	4.8	4.0	
(Transfer)	Dry fill	1.1	1.2	1.0	
	Drain and refill	0.8	0.8	0.7	
A340F	Dry fill	7.6	8.0	6.7	
	Drain and refill	1.6	1.7	1.4	
Transfer oil	W56 (RF 1 A)	1.6	1.7	1.4	API GL-4 or GL-5
	G 58, R 150F, A340F (VF 1 A)	1.1	1.2	1.0	SAE 75W-90
Differential oil					Standard differential
2WD	7.5 in.	1.35	1.4	1.2	API GL-5 hypoid gear oil
	8.0 in. 2 pinion	1.8	1.9	1.6	Above -18°C (0°F)
	4 pinion	2.2	2.3	1.9	SAE 90
4WD	Front Standard differential	1.6	1.7	1.4	Below -18°C (0°F)
	A.D.D.	1.86	2.0	1.6	SAE 80W-90 or 80W
	Rear	2.2	2.3	1.9	A.D.
					D. (4WD Front only)
					TOYOTA "GEAR OIL SUPER" oil or hypoid gear oil API GL-5 SAE 75W-90
Steering gear box oil					API GL-4, SAE 90
	2W D	380 - 400 cc 23.2 - 24.4 cu in.			
	4WD	400 cc	24.4 cu in.		